

CRREL

REPORT 86-2



**US Army Corps
of Engineers**

Cold Regions Research &
Engineering Laboratory

Brittleness of reinforced concrete structures under arctic conditions

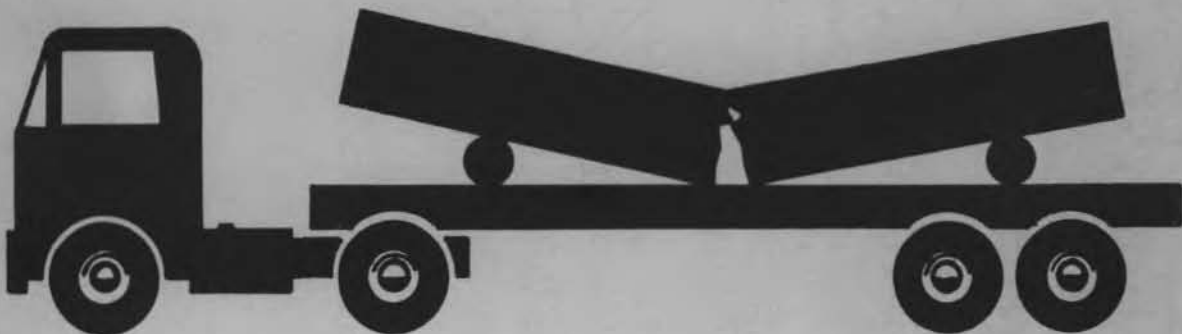
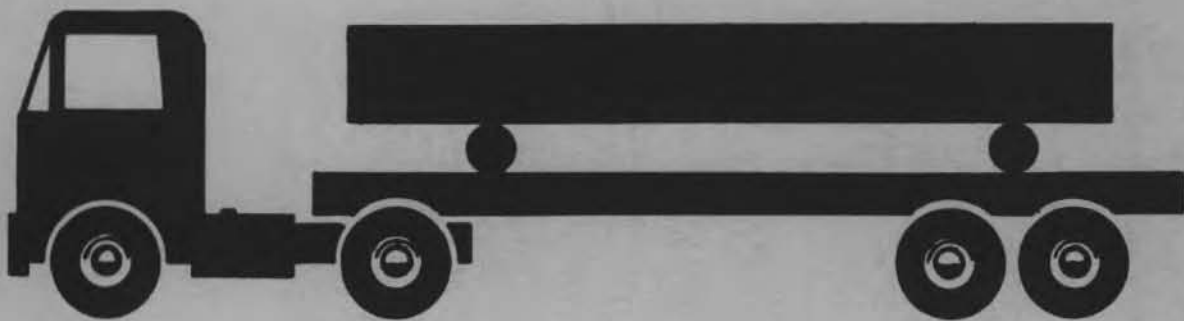

CRREL Report 86-2

May 1986



Brittleness of reinforced concrete structures under arctic conditions

Lauri Kivekäs and Charles J. Korhonen

PREFACE

This report was prepared by Lauri Kivekäs, Research Scientist, Concrete and Silicate Laboratory, Technical Research Centre (VTT) of Finland, and Charles Korhonen, Research Civil Engineer, Civil Engineering Research Branch, Experimental Engineering Division, U.S. Army Cold Regions Research and Engineering Laboratory. This study was conducted as part of a technology transfer agreement between the U.S. Army Corps of Engineers and VTT. The CRREL portion was funded by DA Project 4A762730AT42, *Design, Construction and Operations Technology for Cold Regions*, Task BS, *Base Support*, Work Unit 017, *Maintenance and Rehabilitation of Military Facilities in Cold Regions*.

The authors acknowledge the efforts of Albert Wuori, formerly Chief, Experimental Engineering Division, CRREL, and Professor Asko Sarja, Chief, Concrete and Silicate Laboratory, VTT, for coordinating this study. The authors also thank Francis Sayles and Charles McKenna of CRREL for their technical review of this report.

The contents of this report are not to be used for advertising or promotional purposes. Citation of brand names does not constitute an official endorsement or approval of the use of such commercial products.

CONTENTS

Abstract	i
Preface	ii
Introduction	1
Tests	2
Test specimens.....	2
Test methods.....	3
Results	5
Impact strength of beams.....	6
Ductility of beams.....	6
Effect of notched bars.....	8
Elastic deflection of beams.....	8
Impact tests on rebars.....	9
Conclusions and summary.....	9
Literature cited.....	10
Appendix A: Beam crack patterns.....	11
Appendix B: Photomicrographs of failure surfaces of some steels.....	13

ILLUSTRATIONS

Figure	
1. Beam reinforcements.....	2
2. Rebar test specimens.....	3
3. Beam test setup.....	4
5. Drops needed to break tension reinforcement.....	6
6. Impact strength of unreinforced beams.....	6
7. Loads at which reinforced beams first cracked.....	6
8. Permanent deflections of reinforced beams prior to breakage of the tension reinforcing steel.....	7
9. Reduction of area for tension steels upon breaking.....	7
10. Failure surfaces of some rebars.....	7
11. Elastic deflections of unreinforced beams prior to cracking of the concrete....	8
12. Elastic deflections of reinforced beams prior to cracking of the concrete.....	8
13. Relationship between failure energy and temperature for the steels in a Charpy- V test.....	9

TABLES

Table	
1. Concrete beams: types of tension steel and test temperatures.....	2
2. Properties of concrete.....	3
3. Steel composition in addition to Fe.....	3
4. Tested properties of tension steels.....	3
5. Load levels used in the loading of all reinforced beams and of unreinforced beams T7 and T8.....	4
6. Results of reinforced beam tests.....	5
7. Results of unreinforced beam tests.....	5

Brittleness of Reinforced Concrete Structures Under Arctic Conditions

LAURI KIVEKÄS AND CHARLES J. KORHONEN

INTRODUCTION

At sufficiently low temperatures the failure mode of steel becomes brittle, signifying a loss of ductility and a sharp decrease in impact strength. Because of increasing construction activities in arctic regions, some concern has arisen about the possibility of embrittlement of reinforced and prestressed concrete structures at the very low winter temperatures prevailing in these areas. Reinforcing steels (rebars) are known to become brittle within the arctic temperature range when subjected to standard impact tests. In these tests, however, the rebars are bent, which differs decisively from the axial loading of rebars actually experienced inside concrete structures. Moreover, data on the impact strength of reinforced and prestressed concrete structures at low temperatures are limited.

The impact strength of reinforced and prestressed concrete structures can be studied either by testing entire structures or by testing concrete and steel separately and then predicting the behavior of the entire structure from the individual behavior of the components. The temperature at which the failure of steel becomes brittle is called the transition temperature. It depends somewhat on the steel composition and very much on the rate of loading, the size and shape of the specimen, and the presence or absence of notches and their shape.

Research data are abundant^{1,2,8} concerning performance of steels under slow loading. For example, reinforcing and prestressing steels retain good ductility in the +20° to -80°C temperature range. As the temperature is lowered from 20°C, the yield strength increases a little more rapidly than

the ultimate tensile strength, but even at -80°C steels yield well before they fail. Elongation and reduction in cross-sectional areas decrease somewhat but are still considerable at -80°C.

Under rapid impact loading, brittle failure occurs at much higher temperatures than under slow loading. Usually the impact strength of steel is determined with a notched bar impact bend test, such as the Charpy-V test. In this test, a specimen, machined into prismatic shape with a notch in the tensile zone, is loaded to failure with a very rapid transverse impact load. However, the test was developed for structural steel prisms and is not considered suitable for testing reinforcing steels that are subjected to axial loading when in concrete structures. The loading rate in the Charpy test is much higher than the actual highest loading rates of reinforcing steels in concrete structures under impact load.² Furthermore, the shape of the test specimens differs from the shape of reinforcing bars, and it is highly unlikely that sharp notches are present in reinforcing steels used in concrete.

Since the notched bar impact bend test is a standardized test method (see, for example, ASTM A370) it has been used over the years for testing the impact strength of reinforcing steels. Consequently no research data are available from more suitable types of tests. In Charpy-V tests the transition temperature range of reinforcing steels has been +20° to -20°C.^{1,2} These results are of little use in determining the impact strength of reinforced concrete structures in arctic regions; they are suitable only for comparing the behavior of different steels.

Prestressing steels, which are of higher strength, seem to perform better than reinforcing steels. The impact strength of unnotched specimens,^{3,4,8}

wedge-anchor notched specimens⁴ and specimens with a U-notch⁸ is unaffected by the lowering of temperature in the +20° to -80°C range. The impact strength of V-notched specimens^{2,3,4} decreases gradually, but usually without any clear transition temperature, and the temperature where the impact strength is half its +20°C value is much lower than the transition temperature of reinforcing steels.

The impact strength of unreinforced concrete increases at low temperatures. In tests where notched concrete prisms were loaded with a Charpy hammer,⁶ the impact strength at -45°C was found to be 50% higher than it was at +20°C. Only one impact test of hollow core prestressed concrete slabs without notches in the steels has been conducted at -30°C.⁵ There was no reduction in the impact strength compared to that at +20°C.

The purpose of this study was to determine if lightly reinforced beams would fail in a brittle manner when subjected to the low temperatures and impact loads that might be imposed during the transportation and erection of structures in the Arctic. These results were compared to the impact behavior of reinforcing steels in Charpy-V tests.

TESTS

Impact strengths of concrete beams and individual reinforcing steels (rebars) were tested at temperatures from +20° to -70°C. The concrete beams were tested in bending with a falling weight while the rebars were tested with the Charpy notched bar impact bend test.

Test specimens

A total of 45 concrete beams measuring 150 × 300 × 1500 mm were fabricated for the tests. Of the beams, 36 were reinforced (as shown in Fig. 1) and 9 were unreinforced. Two types of tension reinforcements were used: hot rolled deformed bars and cold worked smooth bars. Half of the tension steels were given U-notches about 2 mm deep and 5 mm wide. The beams were distributed according to their tension reinforcement into five groups as depicted in Table 1. Table 1 also shows the different temperature ranges used during testing.

For the rebar impact test, 10 specimens (as shown in Fig. 2) were machined from both types of bar. The shape of these specimens differed from that of the standard Charpy-V test specimens. The original shape of the reinforcing bars

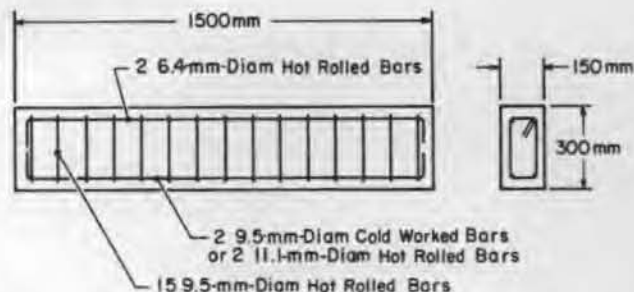

Figure 1. Beam reinforcements. Their yield/tensile strengths are 324/455 Mpa for 6.4- and 9.5-mm-diam hot rolled bars, 449/552 Mpa for 9.5-mm-diam cold worked bars, and 276/414 MPa for 11.1-mm-diam hot rolled bars.

Table 1. Concrete beams: types of tension steel and test temperatures. Temperatures were measured with thermocouples for beams 1, 2, 3, 7, 8 and 9 and estimated for beams 4, 5 and 6.

Type of tension steel	Beam markings	Beam temperatures at onset of cracking (°C)
Hot rolled deformed bars without notches	A1, A2, A3	20, 20, 20
	A4, A5, A6	-23, -26, -24
	A7, A8	-35, -38
	A9	-50
Cold worked smooth bars without notches	B1, B2, B3	20, 20, 20
	B4, B5, B6	-25, -25, -27
	B7, B8	-35, -36
	B9	-63
Hot rolled deformed bars with notches	C1, C2, C3	20, 20, 20
	C4, C5, C6	-24, -28, -27
	C7, C8	-30, -32
	C9	-53
Cold worked smooth bars with notches	D1, D2, D3	20, 20, 20
	D4, D5, D6	-27, -26, -27
	D7, D8	-34, -35
	D9	-54
Unreinforced beams	T1, T2, T3	20, 20, 20
	T4, T5, T6	-27, -27, -28
	T7, T8	-42, -44
	T9	Not tested

was otherwise preserved, but the undersurface was machined flat so that the test specimens would rest firmly on their supports. The depth of the V-notch was 1.5 mm, whereas the standard V-notch is 2 mm deep.

The concrete for the beams was made from high early strength portland cement. The concrete strength was tested with seven standard cylinders and the results are shown in Table 2.

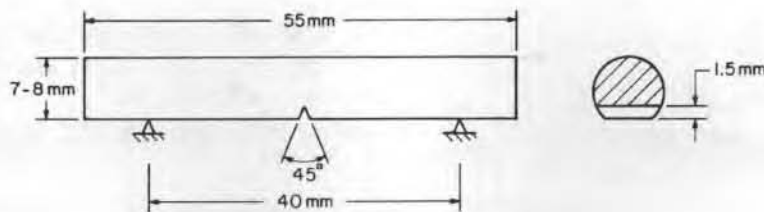

Figure 2. Rebar test specimens.

Table 2. Properties of concrete. The elastic modulus is measured according to RILEM specifications.⁷

Beam groups	Compressive strength (MN/m ²)	Elastic modulus (MN/m ²)
A and T	27.9	27,400
B	20.9	22,400
C and D	22.3	25,700

Table 3. Steel composition (%) in addition to Fe.

Composition (%)	Cold worked smooth bar	Hot rolled deformed bar
C	0.19	0.34
Si	0.30	0.24
Mn	0.84	0.70
S	0.042	0.043
P	0.011	0.015
Cr	0.03	0.10
Ni	0.09	0.11
Mo	0.02	0.02
Cu	0.20	0.33
Al	0.03	0.01
W	0.00	0.01
V	0.01	0.01
Ti	0.00	0.00
Co	0.02	0.01
Sn	0.02	0.02
As	0.03	0.02
O	0.003	0.010
N	0.005	0.009

The steels used in the tests were produced in the United States. Their chemical compositions are shown in Table 3 and their mechanical properties are given in Table 4.

Test methods

The beams were loaded and supported as shown in Figure 3. The loading device used was a falling weight deflectometer (Fig. 4), with which it is possible to drop a weight of 50 to 300 kg from a height of 30 to 400 mm, imparting a 28-ms pulsed load of 7 to 105 kN to a 100- × 150-mm steel plate resting at the midspan of the beam. Loading was performed by dropping increasing loads until the maximum capacity of the machine was reached; then the dropping continued at that maximum load until the steels broke.

All the beams were impact loaded in a 20°C room. Some beams were cooled in a coldroom and then moved to the warm loading room where loading was effected as quickly as possible. The temperature of the coldroom was kept constant at -30°C; this was the temperature of beams 4, 5 and 6 of each test group at the time of removal for loading (Table 1). To reach lower temperatures, an insulated box cooled with liquid nitrogen was built inside the coldroom, and beams 7, 8 and 9 of each test group were further cooled within that box. The temperature rise in the tension steels during loading of reinforced beams 7, 8 and 9 of all four types was monitored with thermocouples and was found to be 0.3° to 0.4°C/min when initially cooled to between -40° and -70°C. The tempera-

Table 4. Tested properties of tension steels.

Steel	Diameter (mm)	Mass/length (kg/m)	Yield strength (N/mm ²)	Tensile strength (N/mm ²)	Elongation A ₁₀ * (%)
Cold worked smooth bar	9.5	0.556	590	605	11.3
Hot rolled deformed bar	9.1	0.563	378	560	24.7

* Elongation measured over bar length equal to 10 times the diameter.

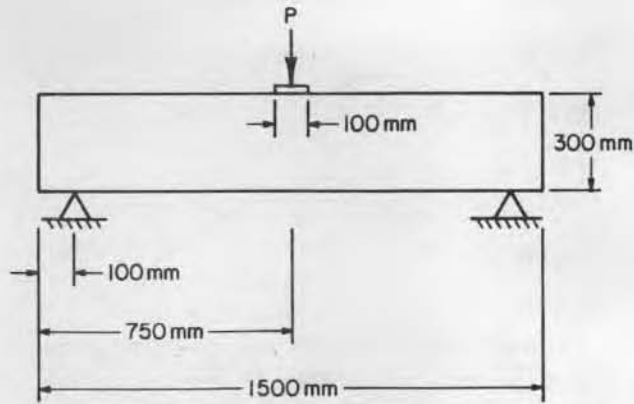

Figure 3. Beam test setup.

Table 5. Load levels used in the loading of all reinforced beams and of unreinforced beams T7 and T8.

Drop no.	Mass/height (kg/mm)	Energy (J)	Range of peak values of the load impulse (kN)
1	100/30	29	10...16
2	100/180	177	18...29
3	200/90	177	28...41
4	200/120	235	34...46
5	200/240	471	47...60
6	300/240	706	54...74
7	300/360	1059	62...87
≥ 8	300/360	1059	48...87



Figure 4. Falling weight deflectometer.

ture rise at the center of unreinforced beams T7 and T8 was found to be about 0.1 °C/min for initial temperatures of -40° to -50 °C. From the time the beams were taken out of the coldroom, 9 to 23 min elapsed before the first cracks appeared in the reinforced beams and 17 to 50 min until the steels broke.

The beams were approximately one month old at the start of the tests, which lasted five weeks. Load levels used with the reinforced beams are shown in Table 5. Load levels for the unreinforced beams varied with temperature, except those for beams T7 and T8 that were the same as the levels

for the reinforced beams. During each drop the peak value of the load impulse was automatically measured with the falling weight deflectometer, and the elastic deflection of the beam was measured with geophones. At each load level each beam reacted a bit differently, which can be seen from the spread in peak load values (Table 5). This is probably due to slight differences in rebar locations, causing changes in rigidity of the beams. Following each drop, the permanent deflection and maximum crack width were measured, the cracks were marked and the beam was photographed.

Impact testing of the reinforcing steel was accomplished with the Charpy-V test, according to Finnish standard SFS 2853,⁹ which is quite similar to ASTM standard A370. The tests were carried out at 10 different temperatures within the range +40° to -70°C, one test bar of each steel for each temperature step.

RESULTS

The beam test results are given in Tables 6 and 7. The test temperature was chosen as that of the tension steels at the onset of cracking of the con-

crete. At that same time the first permanent deflection of each beam occurred, which indicated that the steels had yielded and that the beam was ductile.

None of the tested beams broke in a brittle manner; the steels yielded, the concrete cracked and permanent deflections occurred well before failure of the beams. For these reasons no transition temperatures were noted. Consequently, lightly reinforced concrete beams are not likely to behave in a brittle manner down to the test temperatures of -53°C for hot rolled steel and -63°C for cold worked steel.

Table 6. Results of reinforced beam tests. "Drops" according to sequence shown in Table 5.

Beams	Ist crack		Failure (breakage) of the steels		Max. permanent deflection (mm, avg)	Max. crack width (mm, avg)	Reduction in area of the steels after failure (%)	No. of cracks
	Test temp. (°C, avg)	Drops	(°C, avg)	Drops				
A1,A2,A3	+20	3,3,3	+20	12,16,15	49	18	38.0	4,5,4
A4,A5,A6	-24	6,5,5	-21	12,9,10	25	13	34.7	2,3,2
A7,A8	-36	5,6	-32	9,20	23	13	41.5	1,2
A9	-50	6	-46	12	18	—	46.5	1
B1,B2,B3	+20	2,2,2	+20	14,12,13	32	16	51.0	2,3,3
B4,B5,B6	-26	5,5,5	-23	14,15,10	21	14	44.8	2,1,1
B7,B8	-36	5,5	-30	14,20	33	19	42.7	1,1
B9	-63	5	-51	21	47	25	53.1	1
C1,C2,C3	+20	3,3,3	+20	12,10,7	24	10	17.1	5,4,3
C4,C5,C6	-26	5,5,6	-24	9,8,13	20	9	34.7	3,1,2
C7,C8	-31	6,6	-30	8,9	8	5	28.4	1,1
C9	-53	6	-51	10	12	3	33.2	2
D1,D2,D3	+20		+20	7,15,11	23	12	44.6	3,2,3
D4,D5,D6	-27	5,5,5	-24	13,9,12	14	9	41.0	1,1,2
D7,D8	-35	5,5	-27	15,29	24	12	37.7	2,2
D9	-54	5	-48	13	19	—	23.3	1

Table 7. Results of unreinforced beam tests.

Beams	Test temperature (°C)	Energy for failure (J)	Peak value of failure load impulse (kN)	No. of drops to failure using same loading sequence as the reinforced beams
T1...T3	+20	343	37.9	—
T4...T6	-27	666	81.0	—
T7,T8	—	882	83.6	6,7

Impact strength of beams

The number of drops needed to break the tension steels varied greatly, even between similar beams loaded at the same temperature, perhaps because of the slight variations in rebar locations noted earlier. No reinforced beam failed before the maximum loading capacity of the falling weight deflectometer was reached. Differences occurred only in the number of drops at maximum load. As can be seen from Figure 5, the impact strength, as measured by number of drops, essentially was not diminished by temperature. Beam group A showed a slight decrease in strength, whereas the rest of the beams showed an increase when comparing +20°C to the lowest temperature strength. Group B showed the largest strength increase.

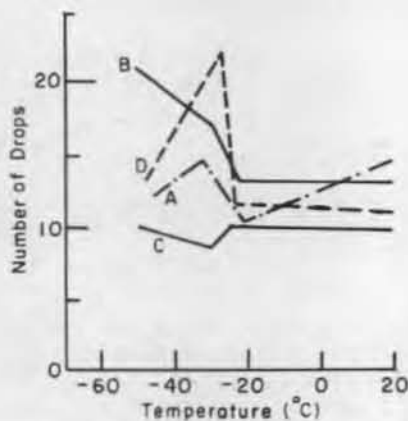

Figure 5. Drops needed to break tension reinforcement (see Table 1 for beam group designations.)

Impact strength of the unreinforced beams increased considerably at low temperatures (Fig. 6). At -43°C the increase, compared to that at +20°C, was about 120%, which was clearly higher than the 50% increase for notched concrete prisms reported in reference 6.

Because of the increased impact strength of unreinforced concrete, the load required for the first occurrence of cracks in reinforced beams also increased considerably at low temperatures, as shown in Figure 7. This was accompanied by a decrease in the number of cracks (Table 6). The crack patterns of the beams are shown in Appendix A. The cracks usually formed near the stirrups, as the area of concrete in these cross sections was the smallest. Had there been no stirrups in the

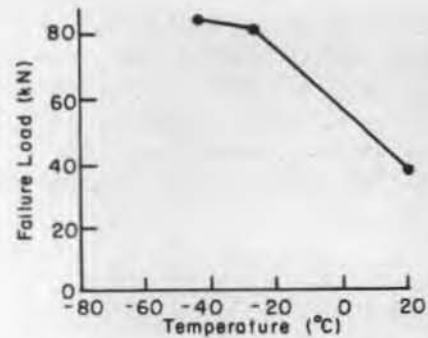

Figure 6. Impact strength of unreinforced beams.

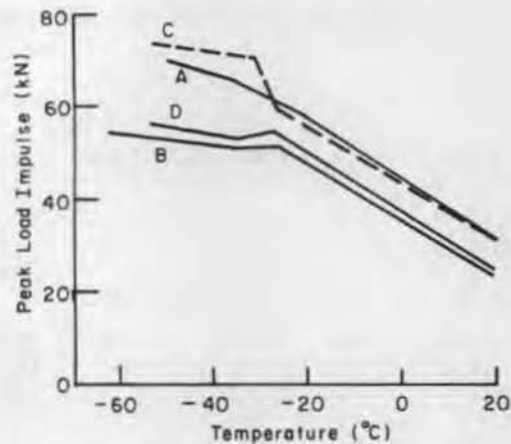

Figure 7. Loads at which reinforced beams first cracked.

middle part of the beams, the load required for formation of the first cracks might have been somewhat higher, as suggested by the higher impact loads of the unreinforced concrete beams in Figure 6.

Ductility of beams

Beam deflections, beam crack widths and reductions in the area of the steel are all important indicators of ductility. However, these measurements vary somewhat, making it difficult to conclude anything other than that the beams remained ductile at low temperatures.

Beams reinforced with hot rolled deformed bars (i.e. beams marked A and C in the figures) behaved similarly with and without notches in the bars. At

low temperatures they did not deflect as much as they did at 20°C (Fig. 8), which is confirmed by the smaller crack widths shown in Table 6. These two measurements indicate that the beams became somewhat less ductile with temperature. On the other hand, the steel area-reduction values increased at low temperatures, indicating a slight increase in ductility. Overall it can be said that the beams in groups A and C remained ductile and were unaffected by the notches.

Beams reinforced with cold-worked smooth bars (i.e. beams marked B and D) in some cases

showed a difference between those notched and unnotched bars. Figure 8 shows group B to significantly increase in deflection, whereas deflections for beams with notches (D) remained unchanged at low temperatures. This is confirmed by the increased crack widths for group B and the more or less stable crack widths for group D (Table 6). The area reduction for group B rebars increased, indicating an increase in ductility at low temperatures, whereas the group D rebars showed the opposite trend (Fig. 9), indicating that notches did affect the ductility of the cold worked smooth steel. But

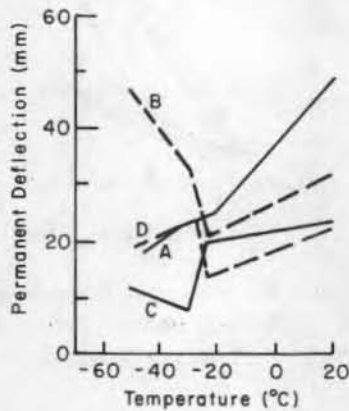

Figure 8. Permanent deflections of reinforced beams prior to breakage of the tension reinforcing steel.

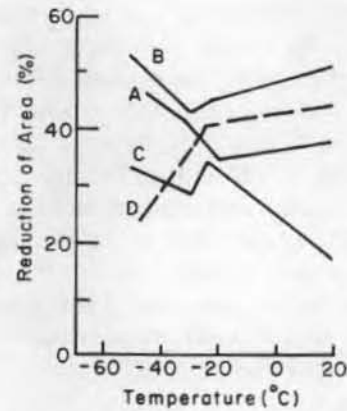
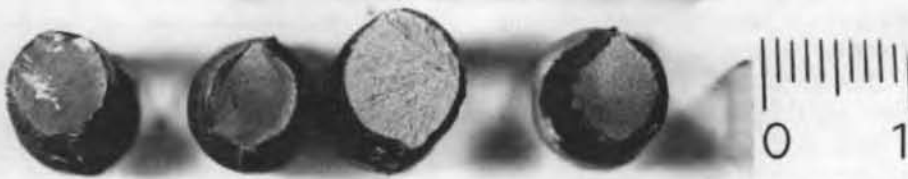

Figure 9. Reduction of area for tension steels upon breaking.

A2 A6 A9



D3 D5 D9



Figure 10. Failure surfaces of some rebars. A 1-cm scale is shown.

as was true for the hot rolled deformed steel, this steel still remained ductile at low temperatures.

In some reinforced beams, area reduction differed between the two tension bars. The reduction in one bar amounted to many tens of percent, while the other bar appeared to fail in a brittle manner with only a small reduction in area. In these cases the apparently brittle bars may have yielded in a different beam cross section before failing. Following failure of the first bar, the second bar was undoubtedly subjected to a very high and rapid impact load at a similar cross-sectional area. Thus it is likely that brittle failure occurred there, even though yielding had taken place elsewhere. Figure 10 is a photograph of the failure surfaces of some bars. The marked difference in cross section is clearly seen in the rebars of beams A6 and D9. In Appendix B the same failure surfaces are shown at $\times 12$ and $\times 1000$ magnification. Following a brittle fracture the surface has a slate-like appearance when viewed at $\times 1000$ magnification; subsequent to a ductile failure the appearance is more net-like. In some of the failure surfaces at low temperatures, the fracture appears partly ductile and partly brittle.

Effect of notched bars

Depending on the size and shape of the notch, the transition temperature of notched steel is usually higher than that of unnotched steel. However, as stated earlier, no brittle failures were noted, even in beams reinforced with notched bars. In the temperature range used, the effect of lowering the temperature did not differ between the beams reinforced with notched or unnotched bars. At each temperature the notches somewhat reduced the impact strength and ductility, although the reduction was not solely temperature-dependent. The notched hot rolled deformed bars in the beams failed approximately three drops earlier than unnotched bars. With cold-worked smooth bars the difference was about one drop.

Elastic deflection of beams

The elastic deflections (i.e. deflections prior to cracking) are shown in Figures 11 and 12. As mentioned earlier, these deflections were measured by geophones and are different from the permanent deflections recorded in Table 6.

For unreinforced beams the elastic deflections (Fig. 11) decreased at low temperatures, which indicates an increase in strength and correlates with the increased impact strength reported earlier. This increased strength can also be seen as an in-

crease in the slope (elastic modulus) of the data lines in Figure 11. For reinforced beams (Fig. 12) the results, although not as clear, show increased concrete strengths at low temperatures. Temperature does not appear to have a clear effect on failure strain.

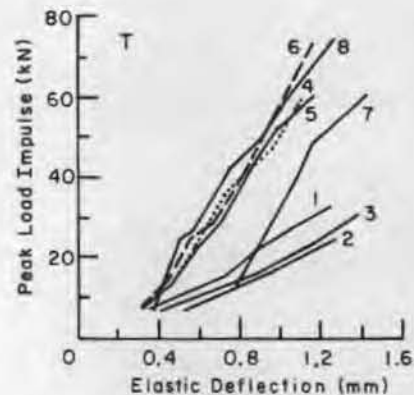

Figure 11. Elastic deflections of unreinforced beams prior to cracking of the concrete.

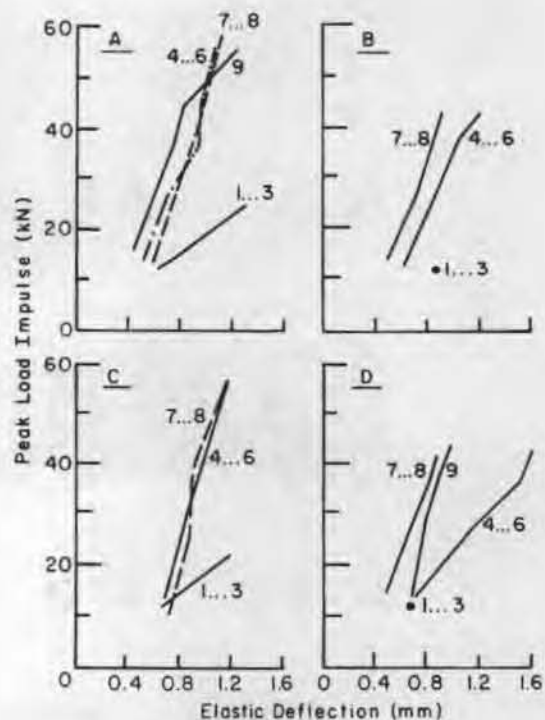

Figure 12. Elastic deflections of reinforced beams prior to cracking of the concrete. See Table 1 to identify reinforcement types for groups A, B, C and D.

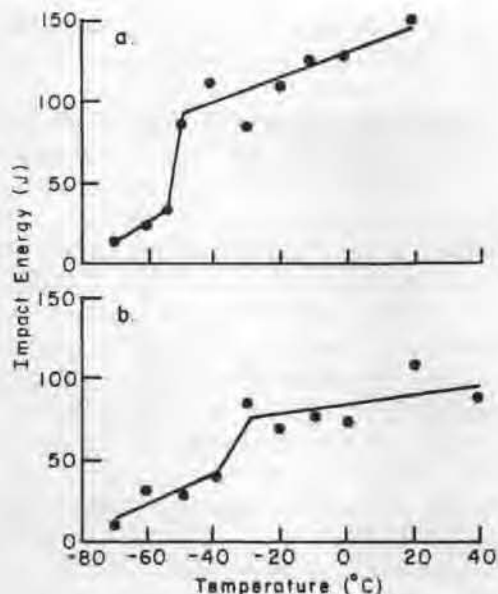

Figure 13. Relationship between failure energy and temperature for the steels in the Charpy-V test. a-cold worked smooth bar, b-hot rolled deformed bar.

Impact tests on rebars

In the Charpy-V test the transition temperature of the hot rolled deformed bar was -30° to -40°C and that of the cold worked smooth bar was -50° to -55°C (Fig. 13).

By comparison, the lowest test temperatures of beams with hot rolled deformed bars (with and without notches) were -53° and -50°C and those with cold worked smooth bars (with and without notches) were -54° and -63°C (Table 1). It is obvious that the Charpy test produced a brittle failure (in all but one case) well above the lowest beam test temperatures. At -53°C the hot rolled deformed bars retained only 30% of their original strength in the Charpy test, whereas the concrete beams reinforced with the same type of steel retained essentially their full impact strength. Likewise the cold worked smooth bars retained only 15% of their strength compared to no loss in strength for concrete beams reinforced with unnotched steel of the same type at -63°C .

For notched cold worked smooth bars this comparison is not as clear. The -50° to -55°C Charpy transition temperature is the same as the lowest test temperature (-54°C) of beams with notched bars. However, it can be said that the Charpy tests showed brittle failure and the beams showed ductile failure.

The transition temperatures in the Charpy-V test are lower than the values of $+20^{\circ}$ to -20°C given in references 1 and 2. This may be due to the non-standard shape of the test specimens, but may also be due to the composition of the steels.

CONCLUSIONS AND SUMMARY

As a result of our tests, we conclude that reinforced concrete beams will not break in a brittle manner in arctic regions under impact loads that normally occur during transportation and erection. In the tests no beams broke in a brittle fashion, although the impact load was severe. All beams retained full impact strength with no significant loss in ductility. Notches in the reinforcing steels did not affect the performance of the beams at the lowest test temperature.

In the tests, reinforced concrete beams showed no brittle failure at temperatures down to -50° and -53°C for beams with unnotched and notched hot rolled deformed tension bars, and down to -54° and -63°C for beams with notched and unnotched cold worked smooth tension bars. These test temperatures are at or considerably lower than the -30° to -40°C and -50° to -55°C transition temperatures for hot rolled and cold worked bars in the Charpy-V test. This in part can be explained by the nature of each test. The Charpy test subjects the rebars to bending, while our testing subjected the rebars in the beams to axial loads. Thus to predict the cold weather performance of concrete structures it is important to simulate actual loading conditions as closely as possible. The Charpy-V test is not considered suitable for determining the transition temperature of reinforcing steel used in concrete structures.

We found that the impact strength of unreinforced concrete increases considerably at low temperatures. This will help to reduce cracking in reinforced concrete structures in cold regions and has a positive effect on the safety of lightly reinforced concrete structures under service conditions. In our tests the percentage of tension reinforcement was 0.3 of the cross-sectional area of concrete. If in practice the percentage of reinforcement is much higher, we do not expect that the increased impact strength of concrete will add much to the safety of the structure.

Our results apply only to the steel types and loading used in the tests. The composition of the steel, particularly its carbon content and grain size, significantly affects its cold embrittlement.

To study the impact behavior of structures reinforced with another type of steel, only the Charpy-V transition temperature should need to be tested and compared to the values obtained in this study. However, it would be best, in order to widen the range of steels for comparison, to conduct additional impact tests on beams reinforced with steels having different Charpy-V transition temperatures.

Since the loading rate also has a significant effect on the transition temperature, the same loading rates used here should be selected in order to apply the results of this study to future studies.

LITERATURE CITED

1. **Browne, R.D. and P.B. Bamforth** (1981) The use of concrete for cryogenic storage: A summary of research, past and present. *First International Conference on Cryogenic Concrete, 25-27 March, Newcastle*. London: The Concrete Society.
2. **Bruggeling, A.S.G. (Chairman)** (1982) Cryogenic behavior of materials for prestressed concrete. FIP State of Art Report, FIP Commission on Prestressing Steels and Systems.
3. **Katsumata, T., H. Oka, Y. Mikami, H. Ojita, Y. Nishimura and I. Tanaka** (1980) Characteristics of steel bars for prestressed concrete at low temperatures. *Sumitomo Electric Technical Review*, **19**: 113-120.
4. **Katsumata, T., H. Oka, Y. Mikami, H. Ojita and Y. Nishimura** (1978) Low temperature characteristics of prestressing steel. *Sumitomo Electric Technical Review*, **18**: 47-56.
5. **Kivekäs, L., S. Huovinen and M. Leivo** (1985) Arctic concrete technology. Technical Research Centre of Finland, Research Reports.
6. **Nasser, K.W. and G.A. Evans** (1973) Low temperature effects on hardened air-entrained concrete: Behavior of concrete under temperature extremes. ACI SP-39. Detroit: American Concrete Institute, pp. 79-89.
7. **RILEM** (1975) Recommendation CPC 8. Modulus of elasticity of concrete in compression. International Union of Testing and Research Laboratories for Materials and Structures, Paris.
8. **Rostasy, F.S., J. Scheuermann and G. Wedemahn** (1982) Behavior of prestressing and reinforcing steel at low temperatures. *Betonwerk und Fertigteil-Technik*, **48**(2): 74-83 and **48**(3): 163-170.
9. **Finnish Standards Association** (1974) SFS 2853 The Charpy V-notch impact test (in Finnish). Helsinki: Finnish Standards Association.

APPENDIX A: BEAM CRACK PATTERNS

Group A—hot rolled deformed tension bars;
 Group B—cold worked smooth tension bars;
 Group C—same as A but with notches;
 Group D—same as B but with notches;
 Group T—unreinforced.

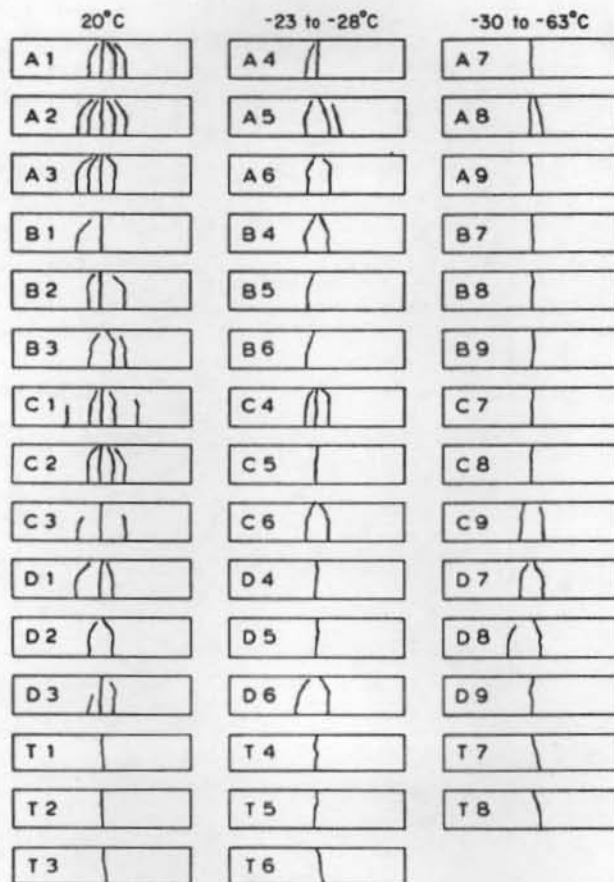

APPENDIX B: PHOTOMICROGRAPHS OF FAILURE SURFACES OF SOME STEELS

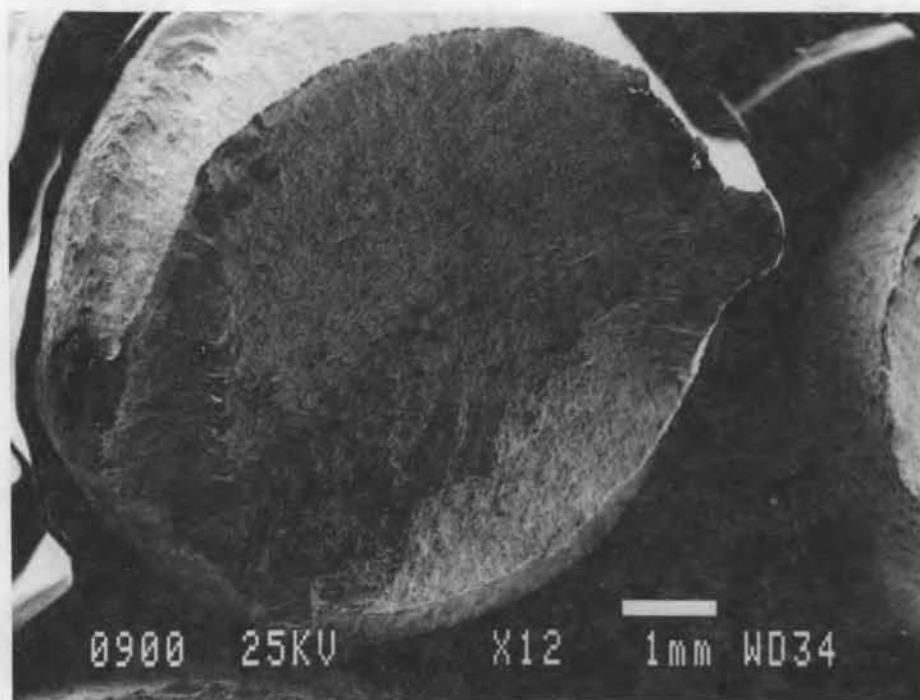

Figure B1. Beam A2 (magnification $\times 12$).

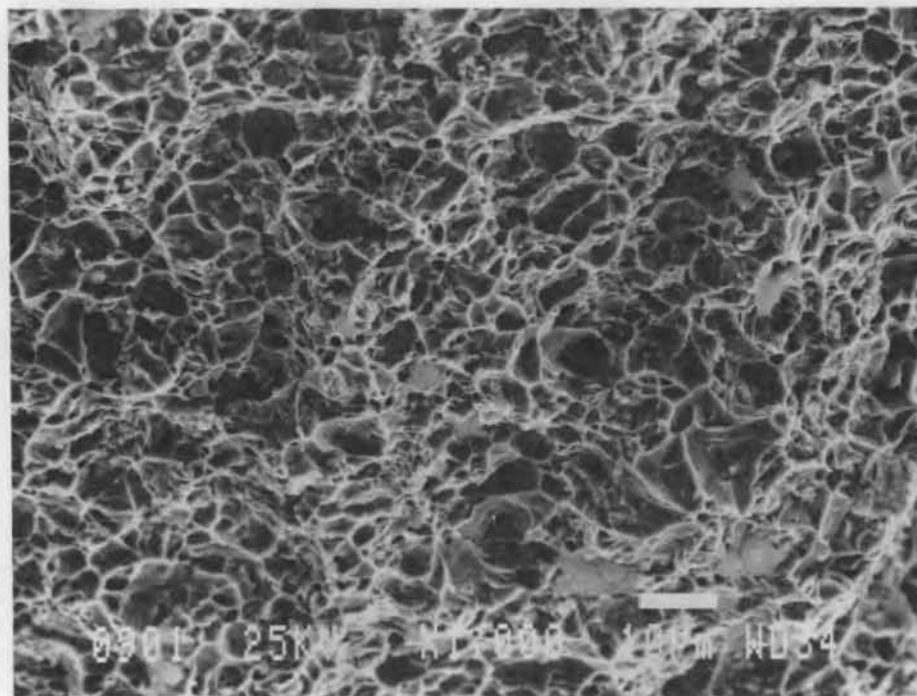

Figure B2. Beam A2 (magnification $\times 1000$).

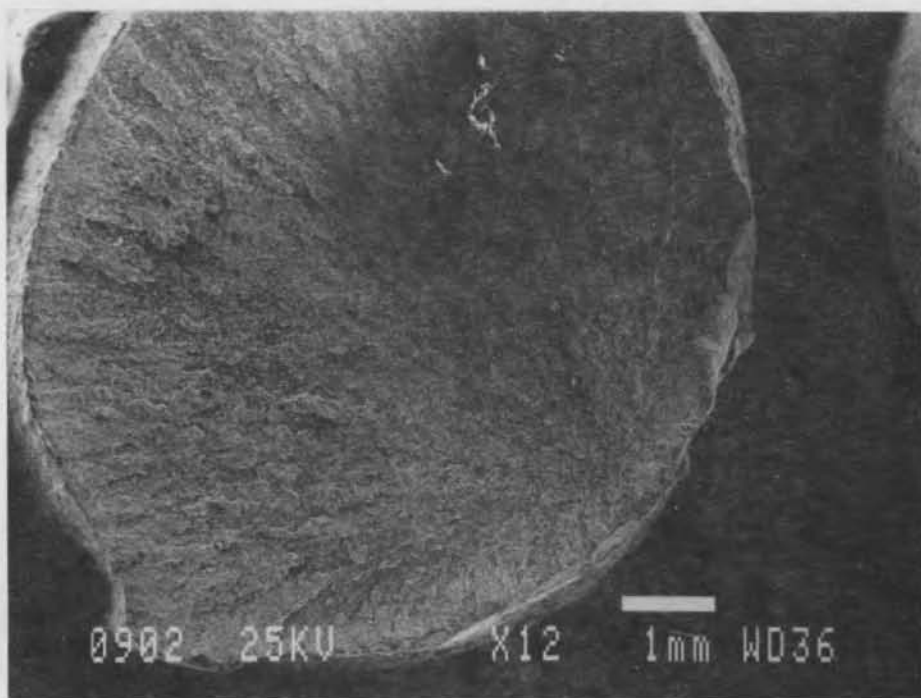

Figure B3. Beam A6, bar 1 (magnification $\times 12$).

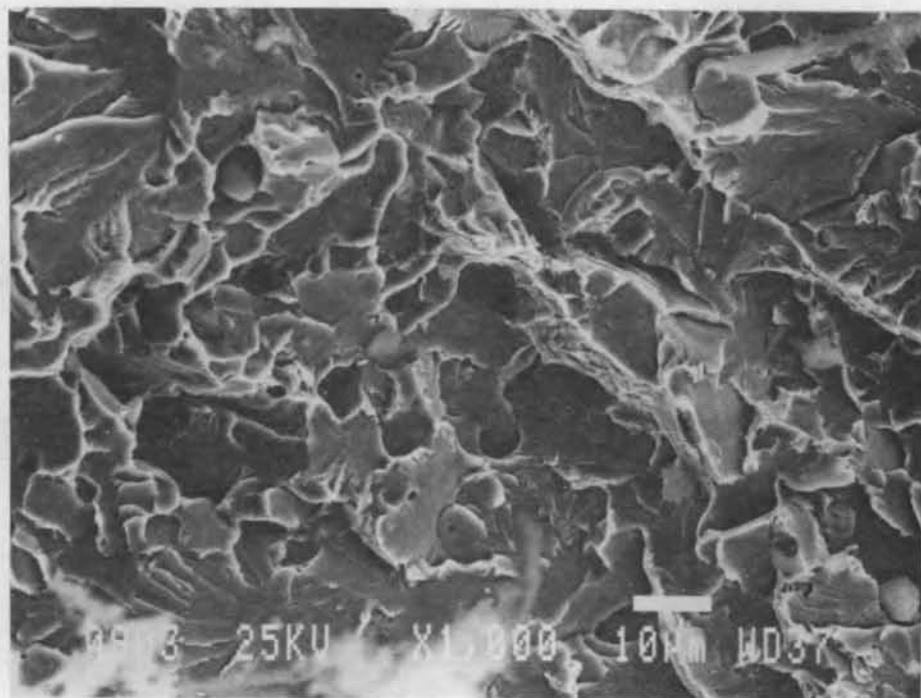

Figure B4. Beam A6, bar 1 (magnification $\times 1000$).

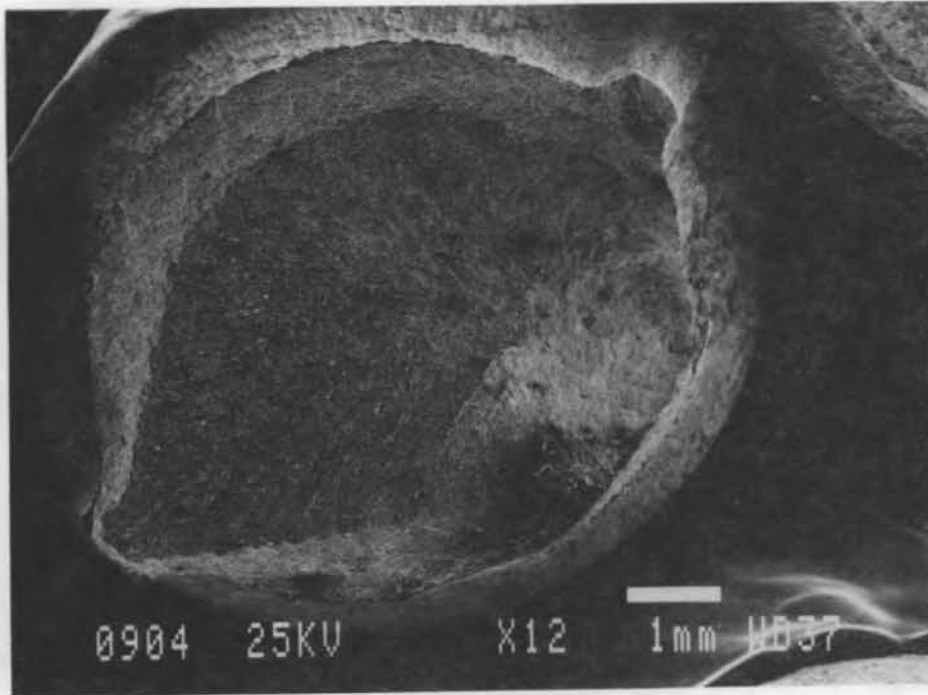

Figure B5. Beam A6, bar 2 (magnification $\times 12$).

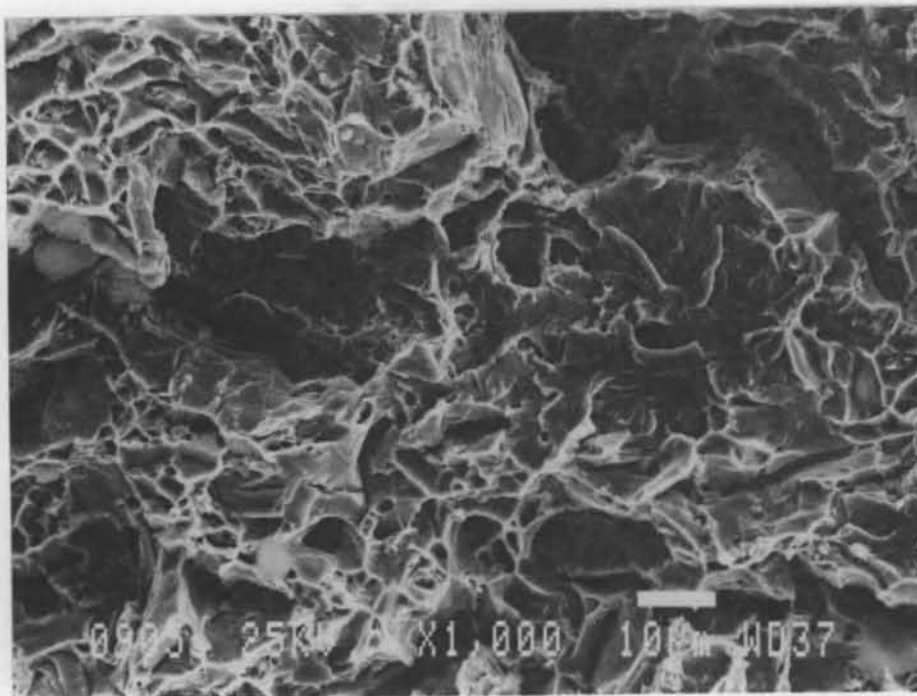

Figure B6. Beam A6, bar 2 (magnification $\times 1000$).

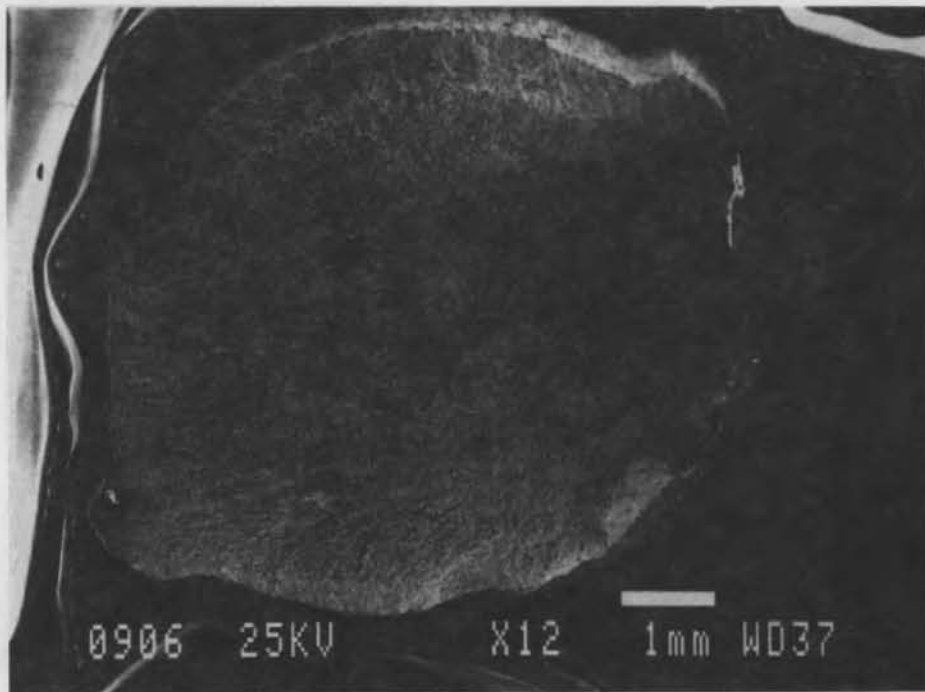

Figure B7. Beam A9 (magnification $\times 12$).

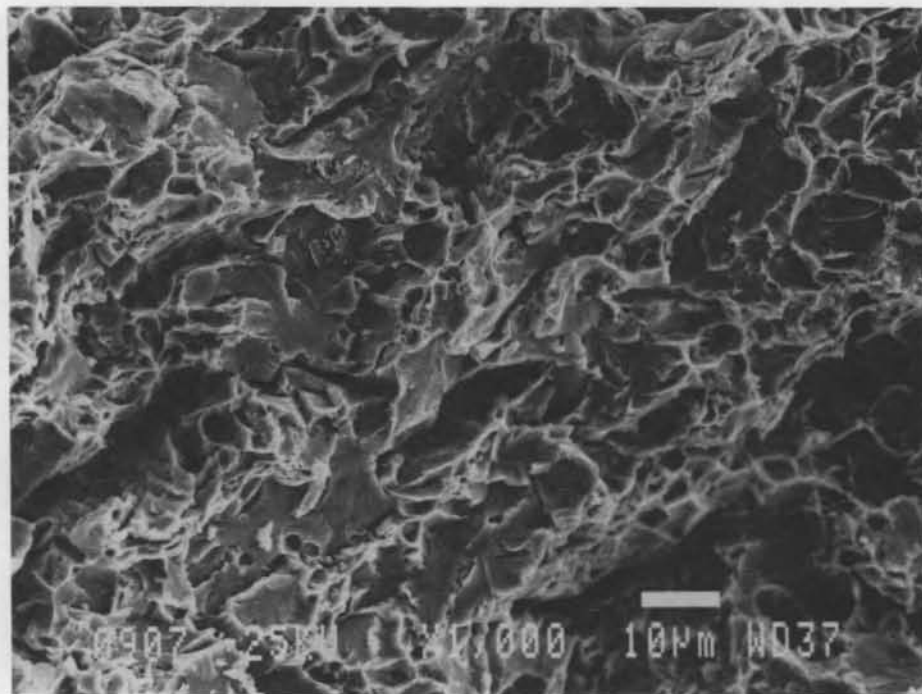

Figure B8. Beam A9 (magnification $\times 1000$).

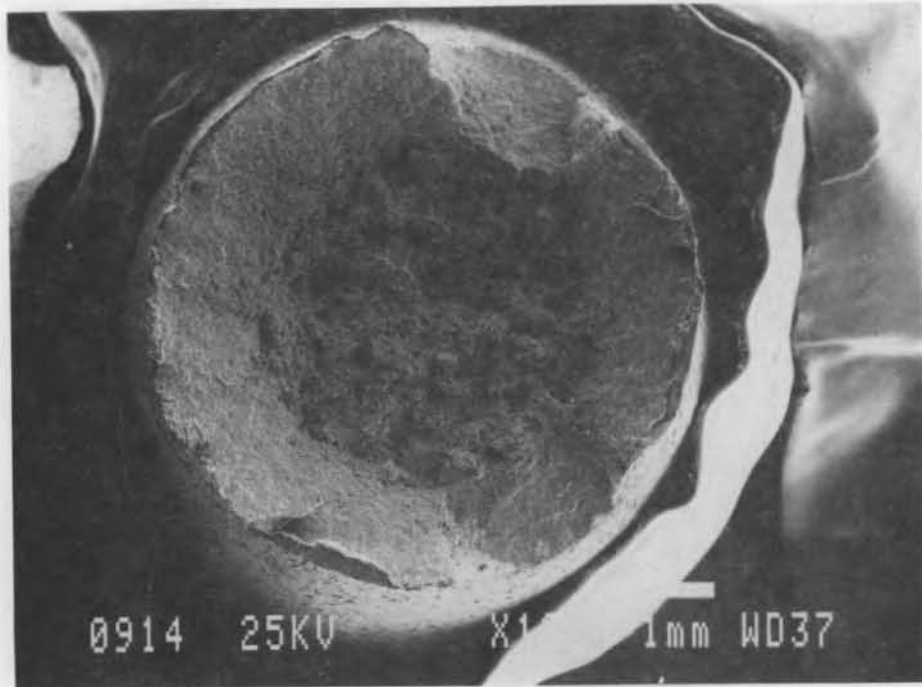

Figure B9. Beam D3 (magnification $\times 12$).

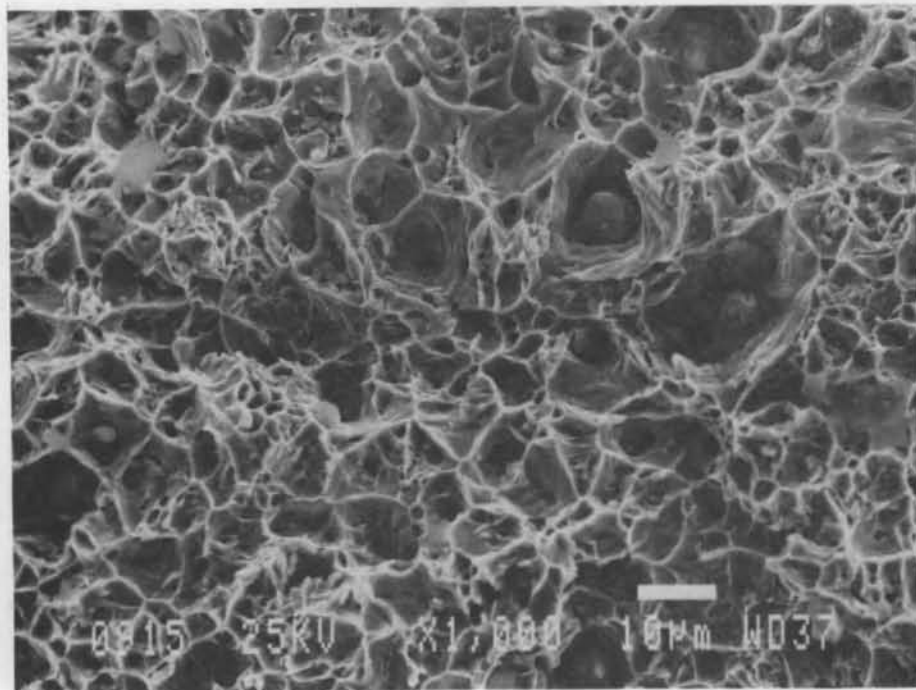

Figure B10. Beam D3 (magnification $\times 1000$).

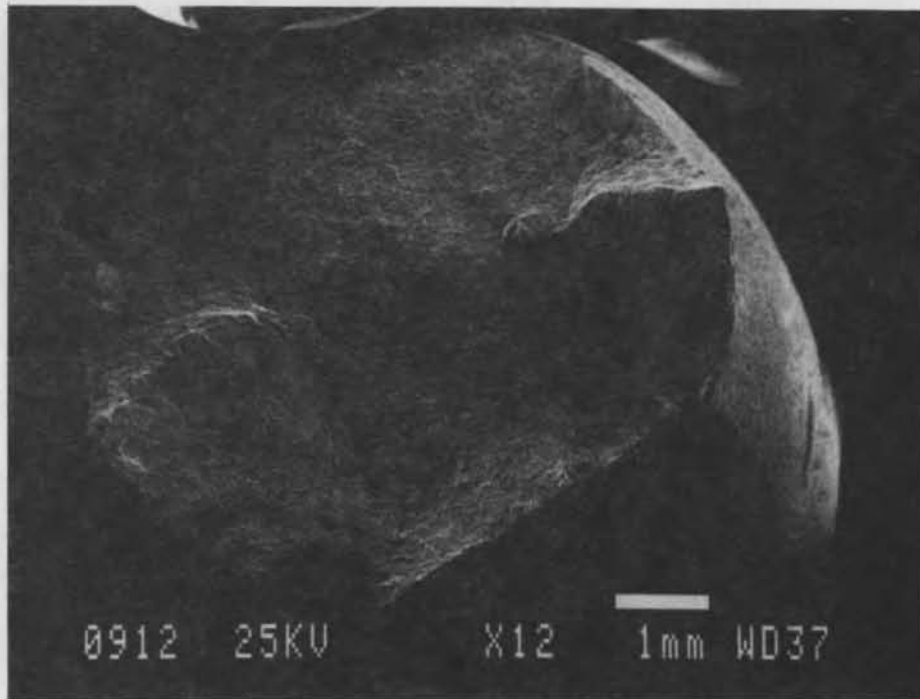

Figure B11. Beam D5 (magnification $\times 12$).

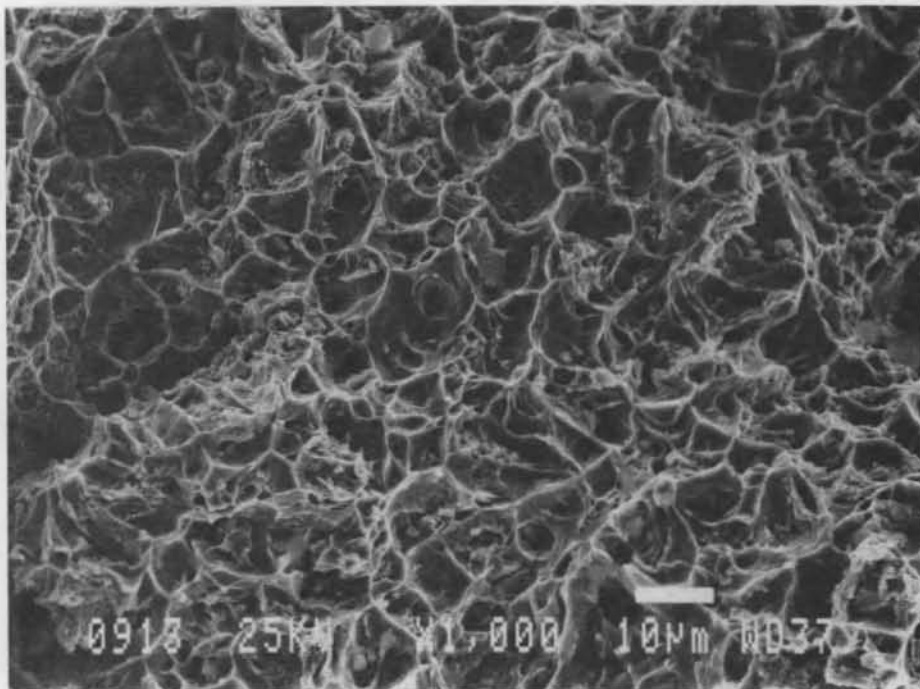

Figure B12. Beam D5 (magnification $\times 1000$).

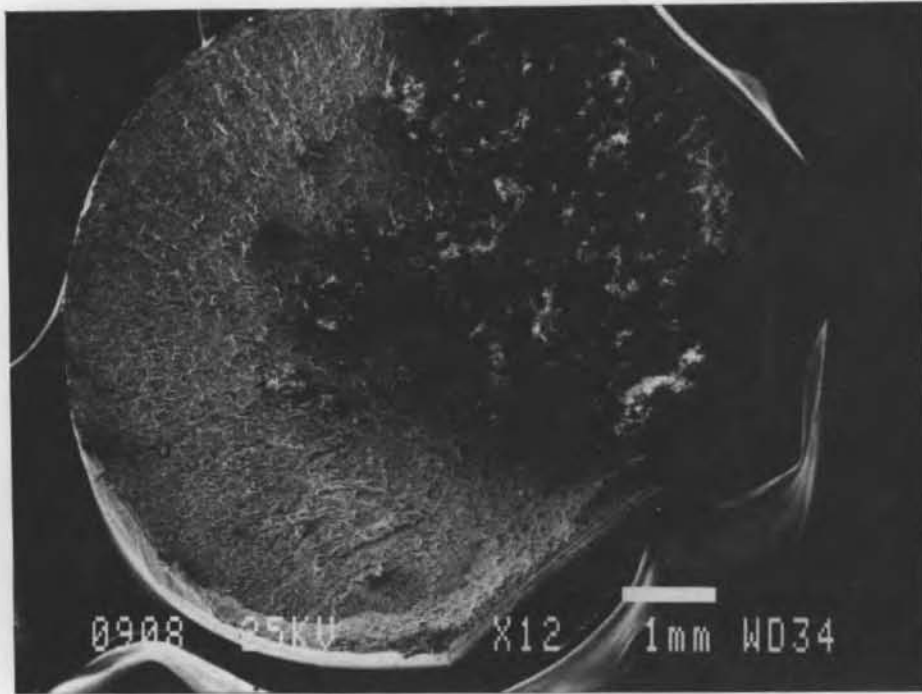

Figure B13. Beam D9, bar 1 (magnification $\times 12$).

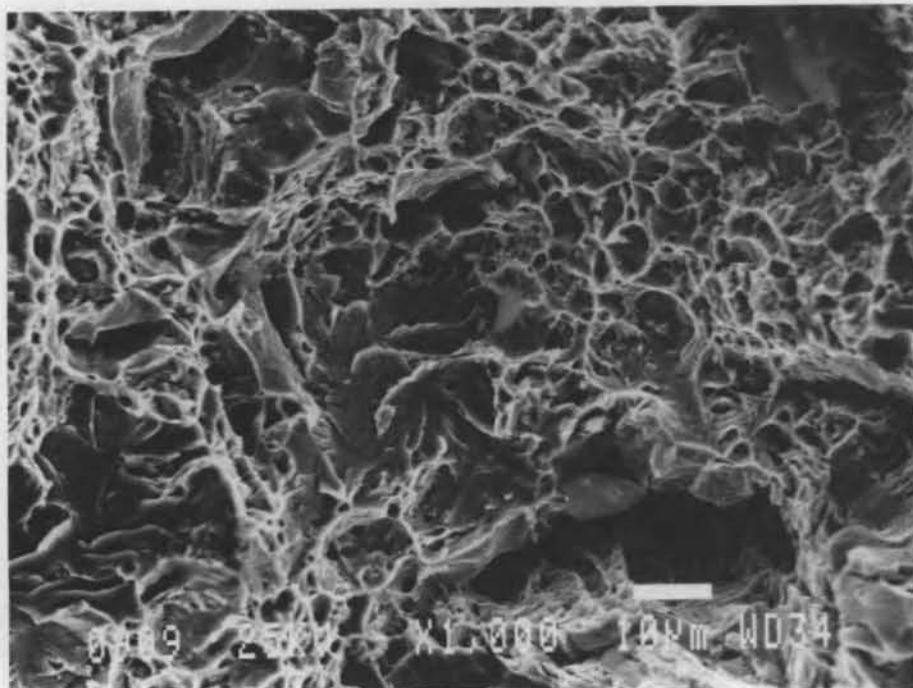

Figure B14. Beam D9, bar 1 (magnification $\times 1000$).

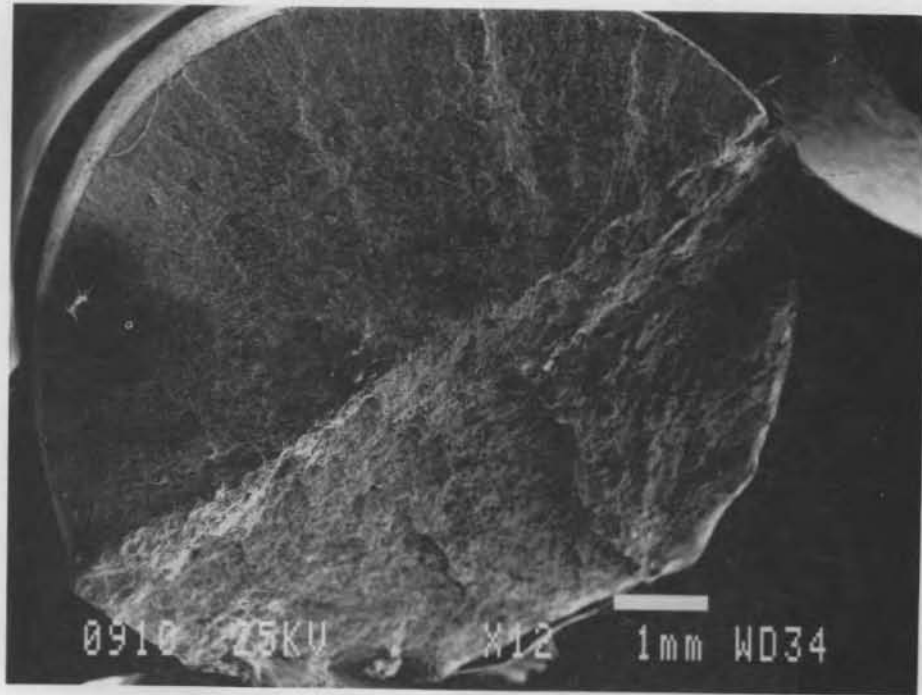

Figure B15. Beam D9, bar 2 (magnification $\times 12$).

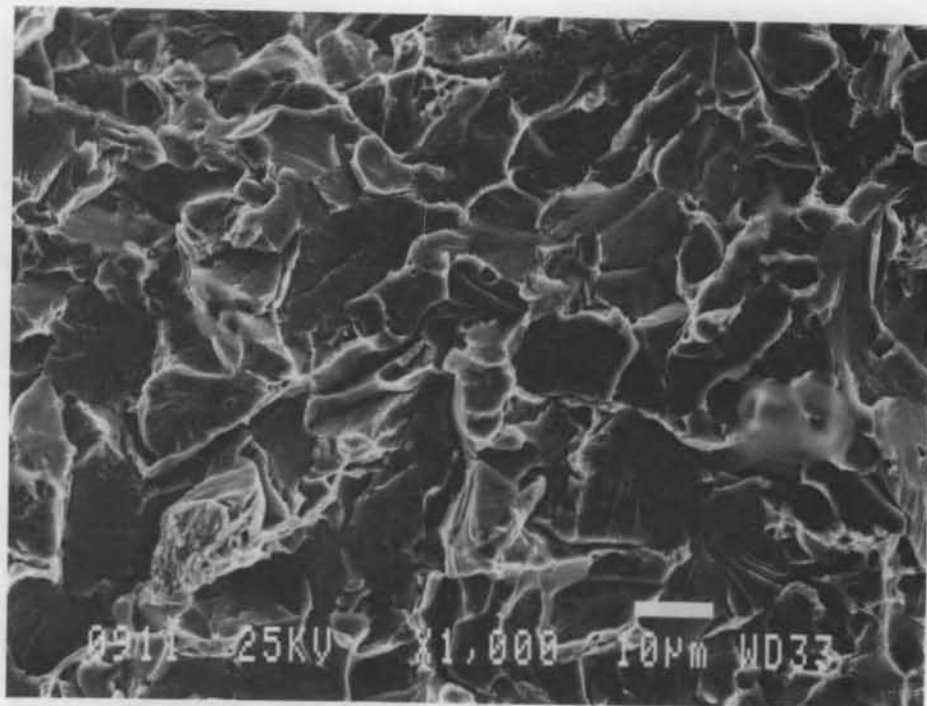

Figure B16. Beam D9, bar 2 (magnification $\times 1000$).

A facsimile catalog card in Library of Congress MARC format is reproduced below.

Kivekäs, Lauri

Brittleness of reinforced concrete structures under arctic conditions / by Lauri Kivekäs and Charles J. Korhonen. Hanover, N.H.: Cold Regions Research and Engineering Laboratory; Springfield, Va.: available from National Technical Information Service, 1986.

iii, 25 p., illus.; 28 cm. (CRREL Report 86-2.)

Prepared for Office of the Chief of Engineers, by U.S. Army Cold Regions Research and Engineering Laboratory under DA Project 4A762730AT42.

Bibliography: p. 10.

I. Arctic regions. 2. Beams (structural). 3. Brittleness. 4. Charpy impact tests. 5. Low temperature. 6. Reinforced concrete. I. Korhonen, Charles J. II. United States. Army. Corps of Engineers. III. Cold Regions Research and Engineering Laboratory, Hanover, N.H. IV. Series: CRREL Report 86-2.