



**US Army Corps
of Engineers**

**ENVIRONMENTAL IMPACT
RESEARCH PROGRAM**

TECHNICAL REPORT EL-86-12

WOOD DUCK NEST BOXES

Section 5.1.2, US ARMY CORPS OF ENGINEERS
WILDLIFE RESOURCES MANAGEMENT MANUAL

by

Kenneth T. Ridlehuber, James W. Teaford

Environmental Laboratory

DEPARTMENT OF THE ARMY
Waterways Experiment Station, Corps of Engineers
PO Box 631, Vicksburg, Mississippi 39180-0631



July 1986

Final Report

Approved For Public Release; Distribution Unlimited



Prepared for DEPARTMENT OF THE ARMY
US Army Corps of Engineers
Washington, DC 20314-1000
Under EIRP Work Unit 31631

Destroy this report when no longer needed. Do not return
it to the originator.

The findings in this report are not to be distributed in an official
Department of the Army position unless so designated
by other authorized documents.

Approved for release by NSA on 05-08-2014 pursuant to E.O. 13526

Unclassified

SECURITY CLASSIFICATION OF THIS PAGE

Form Approved
OMB No 0704-0188
Exp Date Jun 30, 1986

REPORT DOCUMENTATION PAGE

1a. REPORT SECURITY CLASSIFICATION Unclassified			1b. RESTRICTIVE MARKINGS			
2a. SECURITY CLASSIFICATION AUTHORITY			3. DISTRIBUTION/AVAILABILITY OF REPORT Approved for public release; distribution unlimited.			
2b. DECLASSIFICATION/DOWNGRADING SCHEDULE			5. MONITORING ORGANIZATION REPORT NUMBER(S)			
4. PERFORMING ORGANIZATION REPORT NUMBER(S) Technical Report EL-86-12			7a. NAME OF MONITORING ORGANIZATION			
6a. NAME OF PERFORMING ORGANIZATION USAEWES Environmental Laboratory		6b. OFFICE SYMBOL <i>(if applicable)</i>	7b. ADDRESS (City, State, and ZIP Code)			
6c. ADDRESS (City, State, and ZIP Code) PO Box 631 Vicksburg, MS 39180-0631			9. PROCUREMENT INSTRUMENT IDENTIFICATION NUMBER			
8a. NAME OF FUNDING/SPONSORING ORGANIZATION US Army Corps of Engineers		8b. OFFICE SYMBOL <i>(if applicable)</i>	10. SOURCE OF FUNDING NUMBERS			
8c. ADDRESS (City, State, and ZIP Code) Washington, DC 20314-1000			PROGRAM ELEMENT NO.	PROJECT NO.	TASK NO.	WORK UNIT ACCESSION NO. EIRP 31631
11. TITLE (Include Security Classification) Wood Duck Nest Boxes: Section 5.1.2, US Army Corps of Engineers Wildlife Resources Management Manual						
12. PERSONAL AUTHOR(S) Ridlehuber, Kenneth T., and Teaford, James W.						
13a. TYPE OF REPORT Final report		13b. TIME COVERED FROM _____ TO _____		14. DATE OF REPORT (Year, Month, Day) July 1986		15. PAGE COUNT 25
16. SUPPLEMENTARY NOTATION Available from National Technical Information Service, 5285 Port Royal Road, Springfield, VA 22161.						
17. COSATI CODES			18. SUBJECT TERMS (Continue on reverse if necessary and identify by block number)			
FIELD	GROUP	SUB-GROUP	Wood ducks		Wood duck nest boxes	
			Nest boxes		Artificial nesting structures	
			<i>Aix sponsa</i>		(Continued)	
19. ABSTRACT (Continue on reverse if necessary and identify by block number) <p>A management techniques report on wood duck nest boxes is provided as Section 5.1.2 of the US Army Corps of Engineers Wildlife Resources Management Manual. The report was prepared as a guide to assist Corps biologists and resource managers in developing and implementing nest box programs for wood ducks (<i>Aix sponsa</i>) on project lands. Topics covered include assessment of brood habitat, nest box design and construction, placement and installation, personnel and costs, and conditions and limitations.</p> <p>One of the most popular and effective management techniques for wood ducks is the provision of artificial nesting structures. Where natural cavities are limited, increases in local wood duck populations may be expected when nest boxes are properly constructed, located, and protected from predators. Detailed descriptions are provided in this report</p> <p style="text-align: right;">(Continued)</p>						
20. DISTRIBUTION/AVAILABILITY OF ABSTRACT <input checked="" type="checkbox"/> UNCLASSIFIED/UNLIMITED <input type="checkbox"/> SAME AS RPT. <input type="checkbox"/> DTIC USERS			21. ABSTRACT SECURITY CLASSIFICATION Unclassified			
22a. NAME OF RESPONSIBLE INDIVIDUAL			22b. TELEPHONE (Include Area Code)		22c. OFFICE SYMBOL	

18. SUBJECT TERMS (Continued).

Wood duck management
Wood duck habitat
Wildlife management

Management practices and techniques
Waterfowl management

19. ABSTRACT (Continued).

for two basic nest box types, the wooden box and vertical metal box; other acceptable designs are mentioned with their respective advantages listed. A variety of predator guards and supports are described and illustrated. Recommendations are given for the proper placement, installation, and maintenance of wood duck nesting structures.

PREFACE

This work was sponsored by the Office, Chief of Engineers (OCE), US Army, as part of the Environmental Impact Research Program (EIRP), Work Unit 31631, entitled Management of Corps Lands for Wildlife Resource Improvement. The Technical Monitors for the study were Dr. John Bushman and Mr. Earl Eiker, OCE, and Mr. Dave Mathis, Water Resources Support Center.

This report was prepared by Dr. Kenneth T. Ridlehuber, Department of Wildlife and Fisheries Sciences, Texas A&M University, College Station, Tex., and Mr. James W. Teaford, Wetlands and Terrestrial Habitat Group (WTHG), Environmental Laboratory (EL), US Army Engineer Waterways Experiment Station (WES). Dr. Ridlehuber was employed by WES under an Intergovernmental Personal Act agreement with Texas A&M University until his untimely death from cancer in December 1982. Mr. Chester O. Martin, Team Leader, Wildlife Resources Team, WTHG, was principal investigator for the work unit. The following individuals provided helpful comments and information used in the report: Mr. Grafton Anding, Recreation-Resource Management Branch, US Army Engineer (USAE) District, Vicksburg, Vicksburg, Miss.; Mr. David L. Brady, Clarks Hill Lake, USAE District, Savannah, Savannah, Ga.; Mr. Geoffrey L. Dorsey, Fish and Wildlife Branch, USAE District, Portland, Portland, Oreg.; Mr. John R. Fulton, John H. Kerr Reservoir, USAE District, Wilmington, Wilmington, N.C.; Mr. John C. Weber, Environmental Analysis Branch, USAE District, New Orleans, New Orleans, La.; Dr. Thomas E. Morse, Environmental Resources Branch, USAE District, Portland, Portland, Oreg.; Mr. Pete Meyer, Indiana Department of Natural Resources, Pigeon River Fish and Wildlife Area, Mingo, Ind.; Dr. H. W. Heusmann, Massachusetts Division of Fisheries and Wildlife, Westboro, Mass; Dr. Wayne R. Marion, School of Forest Resources and Conservation, University of Florida, Gainesville, Fla.; Mr. Jack Rosebush, USAMC Installation and Services Activity, Rock Island, Ill.; Mr. Robert S. Wardwell, Armed Forces Pest Management Board, Forest Glen Section, Washington, D.C.; and Mr. Michael Stroukoff, US Army Armaments Research, Development, and Engineering Center, Dover, N.J.

This report was prepared under the general supervision of Dr. Hanley K. Smith, Chief, WTHG, EL; Dr. Conrad J. Kirby, Chief, Environmental Resources Division, EL; and Dr. John Harrison, Chief, EL. Dr. Roger T. Saucier, WES, was Program Manager, EIRP. The report was edited by Ms. Jessica S. Ruff of the

WES Publications and Graphic Arts Division (PGAD). Drawings were prepared by Mr. John R. Harris, Scientific Illustrations Section, PGAD, under the supervision of Mr. Aubrey W. Stephens, Jr.

At the time of publication, COL Allen F. Grum, USA, was Director of WES, and Dr. Robert W. Whalin was Technical Director.

This report should be cited as follows:

Ridleyhuber, Kenneth T., and Teaford, James W. 1986. "Wood Duck Nest Boxes: Section 5.1.2, US Army Corps of Engineers Wildlife Resources Management Manual," Technical Report EL-86-12, US Army Engineer Waterways Experiment Station, Vicksburg, Miss.

NOTE TO READER

This report is designated as Section 5.1.2 in Chapter 5 -- MANAGEMENT PRACTICES AND TECHNIQUES, Part 5.1 -- NESTING AND ROOSTING STRUCTURES, of the US ARMY CORPS OF ENGINEERS WILDLIFE RESOURCES MANAGEMENT MANUAL. Each section of the manual is published as a separate Technical Report but is designed for use as a unit of the manual. For best retrieval, this report should be filed according to section number within Chapter 5.

WOOD DUCK NEST BOXES

Section 5.1.2, US ARMY CORPS OF ENGINEERS
WILDLIFE RESOURCES MANAGEMENT MANUAL

BROOD HABITAT	4	PLACEMENT AND INSTALLATION	16
DESIGN AND CONSTRUCTION	4	PERSONNEL AND COSTS	17
Wooden Box	4	Construction	17
Vertical Metal Box	5	Installation	18
Other Boxes	8	Maintenance	18
Predator Guards	9	CAUTIONS AND LIMITATIONS	18
Supports	13	LITERATURE CITED	20

One of the most popular and effective management techniques for wood ducks (*Aix sponsa*) is the provision of artificial nesting structures. Wood ducks readily nest in boxes that are provided as substitutes for natural cavities. A summary of 29 nest box studies conducted throughout the species' nesting range indicated wood duck usage rates of 9% to 151%, with an average of 55% (Bellrose 1980). Increases in local nesting populations of wood ducks may be expected when natural cavities are a limiting factor and nest boxes are properly designed, located, protected from predators, and maintained.

Before a wood duck nest box program is initiated, the following questions should be answered: (1) Is adequate brood rearing habitat available? (2) Can the boxes be made essentially predator-proof? (3) Will the boxes be maintained at least once a year between the breeding seasons? If all 3 questions cannot be answered affirmatively, a nest box program may be ineffective and could be a potential liability to a local nesting population. Predation rates for eggs, ducklings, and hens can be high when hens are induced to nest in unprotected boxes (Bellrose 1980) or in submarginal brood rearing habitat (Ridleyhuber 1980), and nest boxes may not be used if they are not cleaned and maintained annually (McGilvrey 1968). Thus, if the proper habitat is not available, or if a long-term management commitment is lacking, project time and money may be better spent on other programs.

BROOD HABITAT

Ideal brood rearing habitat consists of shallowly flooded areas with an interspersion of flooded trees and shrubs, emergent and floating vegetation, and open waterways (McGilvrey 1968, Ridlehuber 1980). Optimum cover composition consists of 30% to 50% shrubs, 40% to 70% herbaceous emergents, and 0 to 10% trees. Small areas of open water well interspersed throughout the cover should constitute about 25% of the area, and there should be 10 to 20 loafing sites per acre. Features such as small islands, muskrat (*Ondatra zibethicus*) houses, stumps, logs, and tussocks of vegetation are acceptable loafing sites and should be scattered throughout the habitat to allow ducklings to leave the water to preen, dry out, and sun themselves (McGilvrey 1968).

Units smaller than 10 acres are marginal for brood rearing habitat if they are separated by more than 50 yd of land (McGilvrey 1968). However, complexes of beaver ponds and/or small streamside areas are acceptable if the individual units are interconnected by water corridors (Hepp and Hair 1977).

DESIGN AND CONSTRUCTION

Many variations in design and materials have been developed for wood duck boxes. Boxes made of rough-cut lumber are initially more readily accepted by wood ducks, but boxes made of other materials are also used and under certain circumstances may be more desirable (Bellrose 1980).

Two box types, the wooden box and the vertical metal box, have been selected for detailed discussion. These styles have been proven effective in numerous studies throughout the wood duck's breeding range and offer many advantages in terms of durability, general effectiveness against predators, and relative ease of construction and maintenance (Bellrose 1980). Other acceptable box types will be mentioned with their respective advantages listed. However, no attempt will be made to catalog all of the existing types and variations.

Wooden Box

Wooden boxes constructed from decay-resistant lumber have a projected life of 15 to 25 years. Recommended woods include baldcypress, redwood, western red cedar, and pressure-treated pine; plywood is generally not sufficiently durable. Some of the commonly used wood preservatives have recently been designated as restricted use pesticides by the Environmental Protection

Agency (EPA). These are pentachlorophenol (penta), creosote, and the following inorganic arsenicals: copper-chromated arsenate (CCA), ammonia-chromated arsenate (ACA), and ammonia-chromated zinc arsenate (ACZA). Thus, extreme care should be employed when handling pressure-treated lumber, and EPA labels and consumer information sheets must be strictly followed when applying the chemicals (Robert S. Wardwell, Armed Forces Pest Management Board, Washington, D.C., pers. commun., May 1986). Wood that has been treated with creosote should not be used (USFWS 1976).

Rough-cut lumber has at least 2 advantages over finished stock: it is generally cheaper, and the rough surfaces provide toeholds for ducklings as they attempt to exit the box. Boxes made of any material other than rough-cut lumber should have a ladder of hardware cloth attached to provide a suitable climbing surface (McGilvrey 1968).

Wooden boxes should have floor dimensions of approximately 10 × 10 in. and should be 22 to 24 in. high (McGilvrey 1968). The entrance should be elliptical with a horizontal dimension of 4 in. and a vertical dimension of 3 in.; this size and style of opening will generally deter raccoon predation if the raccoon weighs 10 lb or more (Bellrose 1966). A number of designs are available, and the objectives of the program will influence the selection of a particular design. For example, if banding and tagging adults and ducklings is an important consideration, a top-opening box may be more convenient than a front- or side-opening box. However, for general management purposes, a front- or side-opening design will simplify cleaning and maintenance. The materials and construction details needed for a front-opening design are given in Table 1 and Figure 1. Additional design information for mounting boxes is provided under the subheading Supports. See USFWS (1976) for details of a side-opening design, or Bellrose (1980) for a top-opening design.

Vertical Metal Box

The vertical metal box consists of a 2-ft section of round galvanized furnace pipe 10 to 12 in. in diameter with a conical top and a circular floor (Bellrose 1953). This box design was developed in an attempt to reduce predation by fox squirrels (*Sciurus niger*) on wood duck nests in wooden boxes; the all-metal construction and the steep conical roof virtually eliminate this problem (Bellrose 1980). These boxes are readily accepted by wood ducks, are lightweight and durable, and represent the primary alternative to the wooden

Table 1. Materials needed to build wooden nest boxes and 12-in.-diam vertical metal boxes

Item	Quantity	
	Per Box	Per 100 Boxes*
<u>WOODEN BOX</u>		
<u>Lumber</u>		
1 × 12 in.	11 bd ft	1200 bd ft
<u>Nails</u>		
8-penny box, ring-shank or screw shank	40	35 lb
Staples, poultry netting, 3/4 in.	6	1-1/2 lb
<u>Hardware</u>		
Hinges, 3-in. T, light duty	2	220
Hook and eye set, 2-1/2 in.	1 set	110 sets
Hardware cloth, 1/2- × 1/2-in. mesh	64 sq in. (4 × 16 in.)	17 lin ft of a 24-in.-wide roll
Lag screws, 3/8 × 3-1/2 in. or hanger bolts (with nuts)	2	220
Flat washers, 3/8 × 2 in.	2	220
<u>METAL BOX</u>		
<u>Galvanized steel furnace pipe</u> 26- to 28-ga, 12-in. diameter, 24 in. long	1	100
<u>Galvanized sheet metal, 26- to 28-ga</u>		
Roof (16-1/4 × 31 in.)	3.5 sq ft	250 lin ft of a
Floor (13-1/2 × 13-1/2 in.)	1.25 sq ft	20-in.-wide roll
<u>Hardware</u>		
Hardware cloth, 1/2- × 1/2-in. mesh	64 sq in. (4 × 16 in.)	17 lin ft of a 24-in.-wide roll
Lag screws, 3/8 × 3-1/2 in. or hanger bolts (with nuts)	1	110
Flat washers, 3/8 × 2 in.	1	110
Sheet metal screws, No. 6, 1/3 in.**	14	1500

* Quantities given assume a 10% loss or breakage rate.

** Pop rivets may be substituted for sheet metal screws.

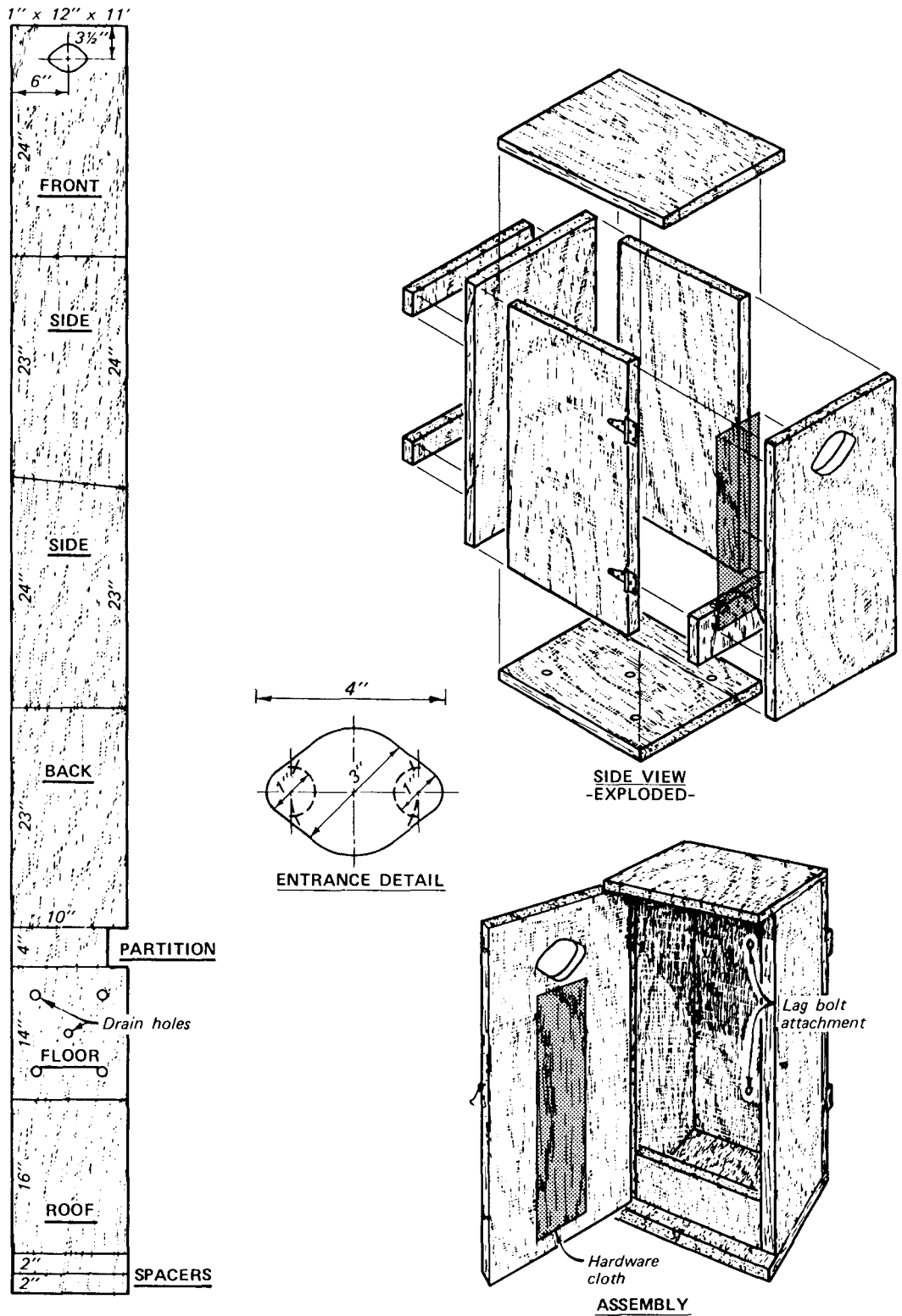

Figure 1. Construction details for a front-opening wooden nest box (entrance detail from Bellrose 1980)

nest box. Table 1 lists the materials and Figure 2 gives the details for constructing a vertical metal box (note that the recommended entrance is again a 3- × 4-in. ellipse, as in the wooden box).

Other Boxes

McGilvrey and Uhler (1971) developed a horizontal metal box with a large opening on one end. These boxes were found to be effective in reducing starling (*Sturnus vulgaris*) occupancy while remaining generally acceptable to wood ducks. For design details and materials required, see USFWS (1976).

Surplus ammunition boxes can be a source of durable, inexpensive wooden nest boxes when they are available. Pete Meyer (Indiana Department of Natural Resources, pers. commun., March 1982) reported using a variety of ammo boxes as wood duck nest boxes. Boxes approximately 10 to 12 in. sq × 18 in. tall

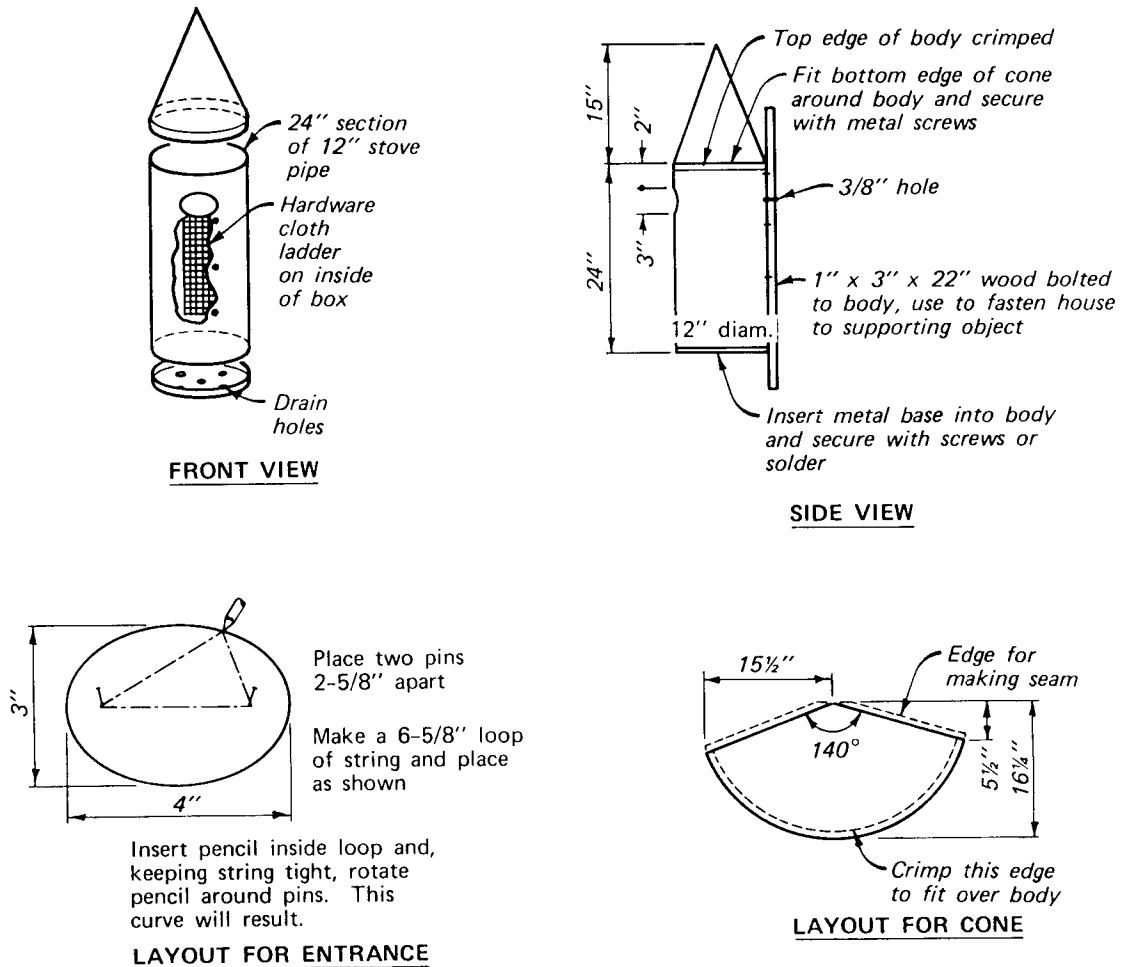

Figure 2. Construction details for a 12-in.-diam vertical metal nest box (after Bellrose 1980)

were preferred, but almost any box could be taken apart and reconstructed to appropriate specifications. Care should be taken not to use older boxes treated with penta; current Department of Defense regulations prohibit the use of penta as a wood preservative for ammo boxes and pallets (Jack Rosebush, USAMC Installation and Services Activity, Rock Island, Ill., pers. commun., April 1986). Penta-treated boxes can be identified by the presence of a P, which stands for preservative, stamped on the bottom. If the boxes are painted green and marked with a P, they have been treated with copper naphthenate. However, penta-treated pallets used by the US Navy (MIL-P-15011 series) have had a green dye added to the wood. Replacement preservatives of choice for dip treatment currently are 1.8% copper-8-quinolinolate (marked with the letters PA), 3% zinc naphthenate (PB), and 2% copper naphthenate (PC), as waterborne solutions (Michael Stroukoff, US Army Armaments Research, Development, and Engineering Center, Dover, N. J., pers. commun., May 1986).

Plastic 5-gal buckets have been modified and used as nesting boxes (Griffith and Findley 1981). These boxes are inexpensive and, depending on the type of plastic used in the buckets, may last 20 years or longer (Norman and Riggert 1977). Modified nail kegs have been used with varying success (Klein 1955, Jones and Leopold 1967). Prefabricated wood duck nest boxes are available commercially. They are generally lightweight and require a minimum of construction time.

Predator Guards

All nest boxes should be protected from predation. Predators may develop a search image for nest boxes and attempt to investigate each box they encounter, thus unprotected nest boxes may contribute little to a local wood duck nesting population. In fact, because nest boxes are more conspicuous than natural cavities, unprotected boxes may actually cause local population declines as a result of increased predation (Bellrose 1980).

At least 5 types of predator guards are in common use: a metal cone and a metal "sandwich" for wooden or metal posts (USFWS 1976); a metal band for tree trunks (Beshears 1974); a metal facing with an oval hole (Bellrose 1953); and a wooden tunnel (McLaughlin and Grice 1952) for wooden boxes (Figs. 3 and 4). The first 3 are generally effective against all climbing predators; the latter 2 only against raccoons weighing 10 lb or more. A pyramid shield has been developed as an alternative to the standard cone (Fig. 5). This

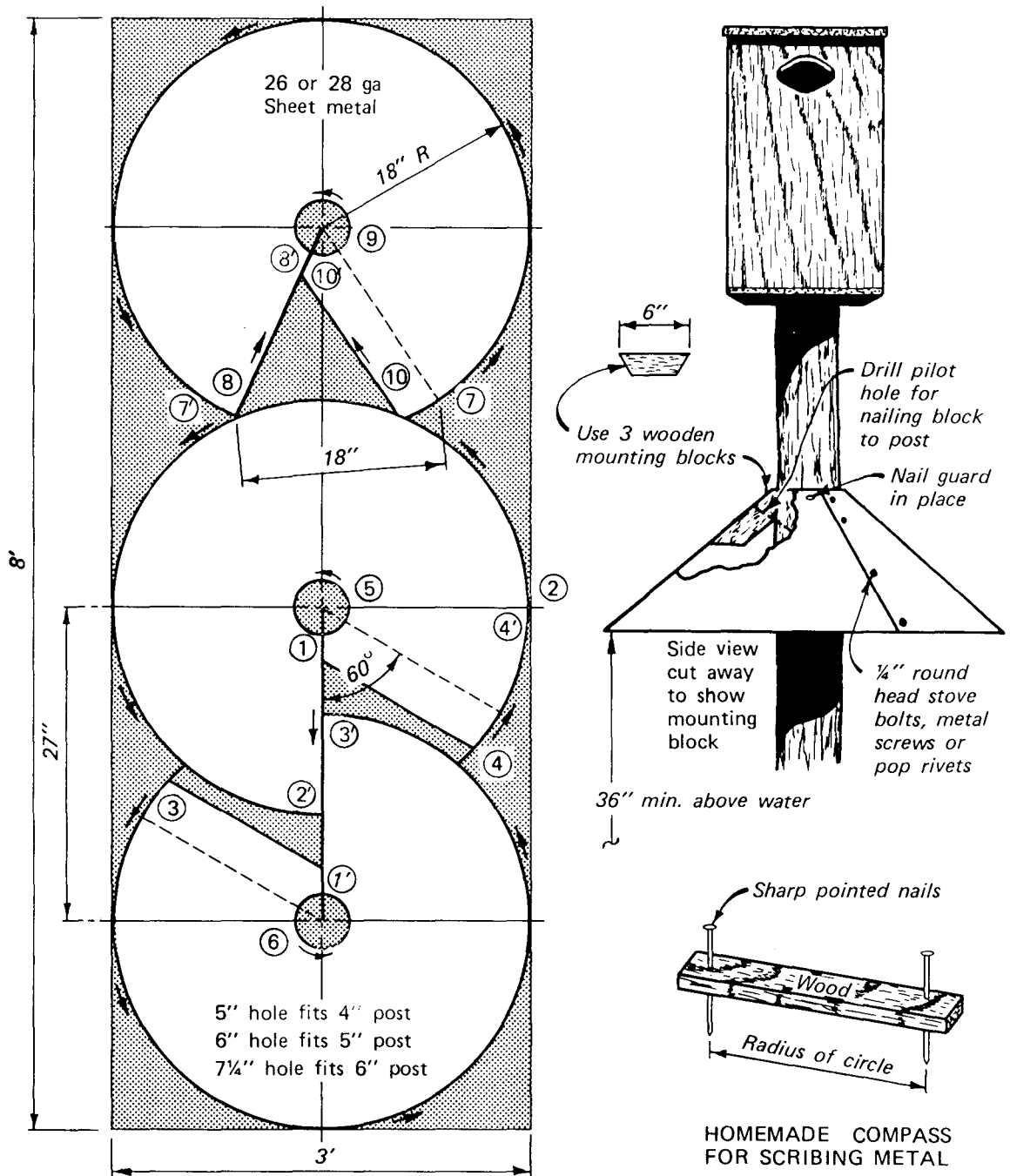

To facilitate cutting (on solid lines only) follow the sequence of numbers. Complete each cut before initiating the next (e.g. ① → ①' then ② → ②'). Make circular cuts in counterclockwise direction. To make initial cut at ① make slot with cold chisel. Cut complete circles at ⑤, ⑥, and ⑦. When installing guard, overlap the cut edge to the dashed line.

Figure 3. Construction details for a sheet metal cone predator guard (modified from USFWS 1976)

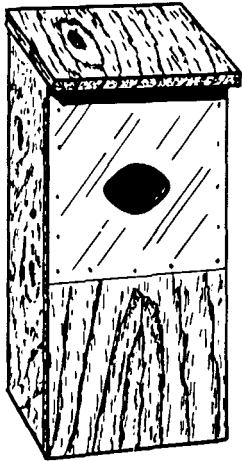

SHEET METAL FACING
(26 GA)

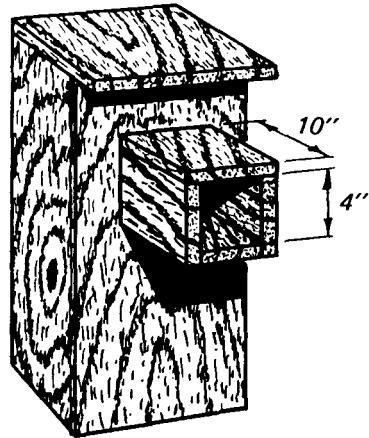

WOODEN TUNNEL

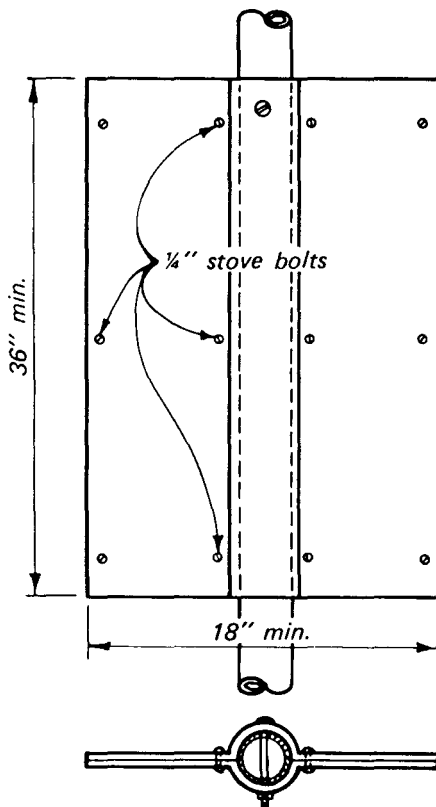

SHEET METAL SANDWICH

Predator Guard for
steel post or pipe.
Made from two 18"
x 36" pieces of
26-ga metal bolted
around post.

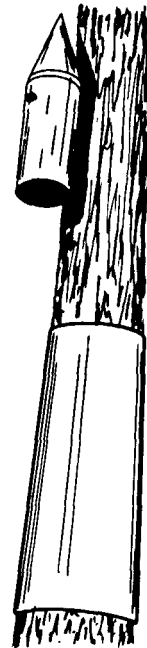

ALUMINUM NEWSPRINT BAND

Figure 4. Four types of predator guards commonly used with wood duck nest boxes

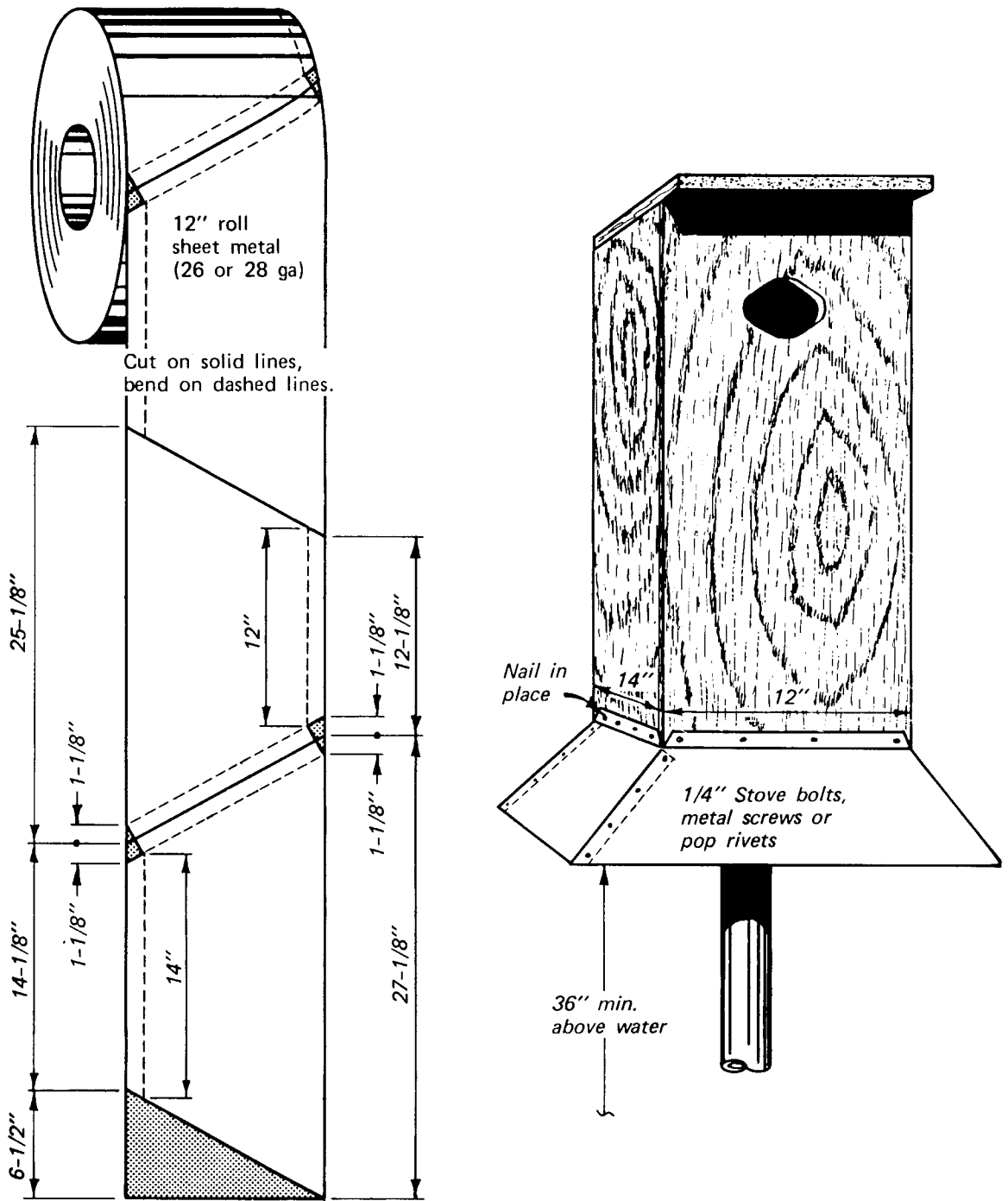

Figure 5. Construction details for a pyramid predator shield

design incorporates the bottom of the box into the shield. Although it is not widely used, it is more economical than the cone and is easier to construct (Ridlehuber, unpubl. data). Table 2 lists the materials required for conical, sandwich, metal band, and pyramid predator guards.

If a cone or pyramid shield is used, the sheet metal must be stiff (e.g., 26-ga galvanized metal) and mounted securely to prevent a raccoon from pulling down one side and climbing over the guard. No openings should exist between a guard and its support because such openings will allow predation by snakes (Webster and Uhler 1964). In addition to providing shields below boxes, ensure that the crowns of adjacent trees do not provide a pathway for predators to reach the nest boxes from above (USFWS 1976).

Supports

Wood duck boxes may be mounted on trees, poles, posts, or pipes. The type of support will depend somewhat on the flooding regime of the local area because each box should have at least a 3-ft clearance between the bottom of the predator guard and the high-water level (Bellrose and Crompton 1972).

Generally, nest boxes should be mounted over open water on posts, poles, or pipes because they can be placed where desired, are easily guarded against climbing predators (McGilvrey 1968), and are not subject to fire ant predation (Ridlehuber 1982). Treated wooden posts, surplus metal pipe, and surplus highway signposts are acceptable supports. Surplus drill stem will serve as excellent nest box supports if available. Smaller diameter pipe may be telescoped into larger diameter pipe for raising and lowering boxes. Holes burned through the bottom of the upper pipe and the top of the lower pipe allow them to be bolted together; two bolts should be used for greater stability.

Supports should be stable, and boxes should be firmly attached. Boxes that wobble excessively may be rejected as nest sites (Bellrose and Crompton 1972). In some areas with soft bottoms, a cross brace may be necessary to prevent the post or pipe from sinking or leaning (Webster and Uhler 1964, Heusmann et al. 1977).

A nest box may be attached to a pole or a tree using a lag screw, a hanger bolt, a board and nails, or a bracket. Grafton Anding (USAE District, Vicksburg, pers. commun., September 1983) suggested that a 1- × 4-in. board be attached to the back of wooden boxes to facilitate mounting. The board should

Table 2. Materials needed to build predator guards for wood duck nest boxes

Item	Quantity	
	Per Shield	Per 100 Shields*
<u>CONICAL GUARD</u>		
Galvanized sheet metal, 26-ga, 3- × 8-ft sections	1/3 section (36 × 36 in.)	35 sections
Wood, 2 × 2 × 6 in.	3	160 lin ft
Sheet metal screws (No. 6, 3/8 in.)**	4	450
12-penny galvanized box nails	3	4 lb
<u>SANDWICH GUARD</u>		
Galvanized sheet metal, 26- or 28-ga, 20 × 36 in.	2	300 lin ft of 20-in.-wide roll
Stove bolts with lock washers and nuts, No. 20, 1/4 × 1/2 in.**	6	650
No. 20, 1-1/2 in.	1	110
<u>METAL BAND GUARD</u>		
Aluminum newsprint sheets	3	350
Roofing nails, 1-1/2 in.	20	12 lb
<u>PYRAMID GUARD</u>		
Galvanized sheet metal, 12 in. wide, 26- or 28-ga	92 in.	800 lin ft
Galvanized roofing nails, 3/4 in.	16	8 lb
Stove bolts with lock washers and nuts, 1/4 in.**	16	1750

* Quantities assume a 10% loss or breakage rate.

** Pop rivets may be substituted for stove bolts or metal screws.

Bolt (or nail) size depends on type and diameter of support used.

extend 3 to 4 in. above and below the box (Fig. 6a); predrilled holes are made in the extended portions to eliminate difficulties in starting nails. A floor flange made of malleable iron may be used to attach nest boxes to pipes; flanges made of cast iron are brittle and are not recommended. When using a lag screw or hanger bolt to install a vertical metal nest box, one should use a large washer (1-1/2- to 2-in. outside diameter) on the inside of the box to prevent the box from eventually tearing away from its support. John R. Fulton (John H. Kerr Reservoir, USAE District, Wilmington, pers. commun., April 1982) recommended mounting vertical metal boxes with 1/2-in. electrical conduit bent and attached as shown in Figure 6b; he found this technique to render the boxes virtually predator proof, except for aerial predators.

Swedish sectional tree climbing ladders can be used effectively to help mount nest boxes. The ladders are lightweight, portable, and resistant to damage if used with reasonable care (John R. Fulton, pers. commun., April

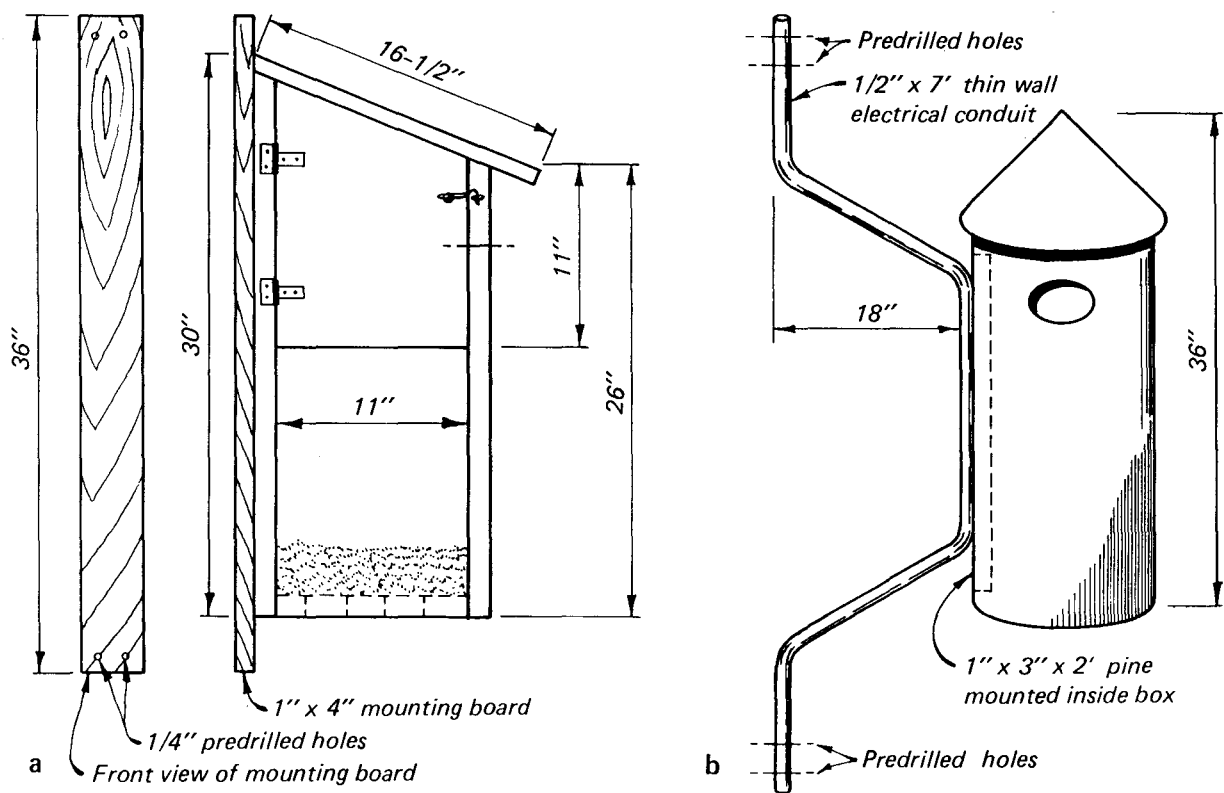

Figure 6. Construction details, side view, for a wooden nest box with board attached for mounting (a); and method for attaching a metal nest box using electrical conduit (b)

1982). Several types of Swedish sectional ladders are available commercially from forestry supply companies.

PLACEMENT AND INSTALLATION

Wood duck nest boxes should be installed over open water in good brood rearing habitat when possible, but they can be effective when placed along shorelines and streambanks. Bottomland hardwood stands are acceptable if they flood at the time of year when hens are searching for nesting cavities, and upland woods may be used if they are within 0.5 mile of permanent water (Bellrose 1980). Nest boxes placed farther than 1 mile from good habitat are of little value to wood duck populations (Bellrose 1953, Ridlehuber 1980). Ground cover present should also be a factor when selecting nest box locations. Geoffrey L. Dorsey (USAE District, Portland, pers. commun., November 1983) found that nest boxes were abandoned by wood ducks where ground cover was dominated by reed canarygrass (*Phalaris arundinacea*); he hypothesized that the dense stands of grass presented an impenetrable barrier to the movement of ducklings.

Nest boxes should be installed in clusters of 3 to 4 boxes, with 50 to 100 ft between the boxes within a cluster (McGilvrey 1968). Initially, ensure that each patch of good brood habitat has at least 1 cluster, rather than saturating a larger area with several boxes. Add additional boxes when nesting use reaches 30% to 50% (McGilvrey 1968) with an upper limit of 4 boxes per acre (Bellrose 1980).

In forest stands or along streams, boxes should be placed at least 10 ft above the ground (USFWS 1976); if the area is subject to flooding, ensure that the bottom of the predator guard is at least 3 ft above the high-water level. Boxes should be placed in areas with relatively open understories where they will be readily visible to hens (Naylor 1964). Along shorelines, the entrance should face the water. Trees used as supports should be alive and sound; dead or dying trees may be suitable initially, but they are safety hazards and will eventually break up or blow over.

Three to 6 in. of nesting material should be placed in each box when it is installed (McGilvrey 1968). Wood ducks use this material to cover their eggs before incubation begins and since they do not carry nesting materials to cavities, boxes probably will not be used if nesting materials are not provided (Webster and Uhler 1964). A number of substances have been used for

this purpose, including wood shavings, shredded sugarcane, hay, Spanish moss, and ground corncobs (McGilvrey 1968). Sawdust may be used in conjunction with other materials but should not be used alone because it tends to pack (Webster and Uhler 1964).

Wasps and bees can be discouraged from using boxes by spraying the interior with a disinfectant (USFWS 1976). Although several managers have reported successfully repelling stinging insects by tacking a strip of insecticide-treated fabric to the interior roof of the box, we are not presently able to recommend this practice because of unknown effects of the pesticide to the health of hens and ducklings. In southern states, it may be necessary to "paint" a 10- to 12-in. band of sticky material (e.g., Tanglefoot, Tack-Trap) around the support to prevent fire ants (Ridleyhuber 1982) and snakes (Johnson, undated) from reaching the box.

PERSONNEL AND COSTS

Estimates of the materials required to construct wooden nest boxes, vertical metal nest boxes, and various types of predator guards are given in Tables 1 and 2. These estimates are given primarily for planning purposes; the actual items and quantities used may vary depending on local availability and preference.

The man-hour and man-day estimates given below are averages developed from personal communications (December 1981) with the following individuals: Grafton Anding, Recreation-Resource Management Branch, USAE District, Vicksburg; David L. Brady, Clarks Hill Lake, USAE District, Savannah; John R. Fulton, John H. Kerr Reservoir, USAE District, Wilmington; H. W. Heusmann, Massachusetts Division of Fisheries and Wildlife; Wayne R. Marion, School of Forest Resources and Conservation, University of Florida; and Thomas E. Morse, Environmental Resources Branch, USAE District, Portland.

Construction

Construction time for wooden nest boxes should average approximately 0.75 man-hour per box (range: 0.25 to 2 man-hours), or 10 man-days per 100 boxes. The time required to construct vertical metal boxes should average 1 man-hour per box, or 13 man-days per 100. The time required to build predator guards should average 0.25 to 0.5 man-hours per guard, or 3 to 6 man-days per 100.

Installation

An average of 1.25 man-hours per box, or approximately 16 man-days per 100 boxes, will be required for installation. Under good conditions the time required to install boxes may be as low as 0.5 man-hour per box or about 6 man-days per 100 boxes. Under more difficult conditions, this time may increase to 2 man-hours per box or 25 man-days per 100 boxes.

Maintenance

Nest boxes should be cleaned and maintained at least once each year. During each visit, old nests and eggshells should be removed and the nesting material replaced as necessary. The boxes should be sprayed with a disinfectant; and the boxes, supports, and predator guards should be repaired as required. One cleaning and maintenance visit per year should require 0.3 to 0.5 man-hour per box, or 4 to 6 man-days per year for 100 boxes; however, 1.0 to 1.5 man-hours per box may be required where boxes have been damaged and/or where sites are less accessible.

CAUTIONS AND LIMITATIONS

It is reemphasized strongly that a successful nest box program must have predator-proof boxes placed in or very close to good brood rearing habitat, and that boxes must be maintained and cleaned at least once annually. Even under ideal conditions with strict adherence to all recommendations, it may take several years for wood ducks to adopt the artificial cavities as nesting sites. Many duck box programs have failed because maintenance was stopped after a few unsuccessful years. Patience in this regard should yield long-term benefits. A good public relations program explaining the objectives of the nest box program and emphasizing its benefits should discourage vandalism and visits from curious recreationists, which could cause nest abandonment.

Many nontarget species are known to nest in wood duck boxes. Common nesters include the starling, flicker (*Colaptes auratus*), red-headed woodpecker (*Melanerpes erythrocephalus*), red-bellied woodpecker (*Centurus carolinus*), common grackle (*Quiscalus quiscula*), American kestrel (*Falco sparverius*), screech owl (*Otus asio*), great-crested flycatcher (*Myiarchus crinitus*), tree swallow (*Tachycineta bicolor*), prothonotary warbler (*Protonotaria citrea*), and Carolina wren (*Thryothorus ludovicianus*) (Grice and Rogers 1965, Cunningham 1969, Heusmann et al. 1977, Ridlehuber 1980). Some of these

species will be considered pests, but others may be desirable as part of a management program; in any event, they must be expected and, in most cases, tolerated.

A number of other ducks also use nest boxes. Some of these species are the common goldeneye (*Bucephala clangula*), Barrow's goldeneye (*B. islandica*), bufflehead (*B. albeola*), hooded merganser (*Lophodytes cucullatus*), and the black-bellied whistling duck (*Dendrocygna autumnalis*). Where use of nest boxes by wood ducks and these other species is a management objective, the entrance should be enlarged to a 5-in. circular opening (Bellrose 1980).

A record-keeping system that includes cost, man-hours, location, utilization data, and other pertinent field notes should be developed and maintained for a wood duck nest box program. The conscientious maintenance of these records will be invaluable in relocating boxes during surveys and in preparing annual reports, work plans, and budgets.

LITERATURE CITED

- Bellrose, F. C. 1953. Housing for wood ducks. Ill. Nat. Hist. Surv., Circ. 45. 48 pp.
- _____. 1980. Ducks, Geese, and Swans of North America. The Stackpole, Co., Harrisburg, Pa., and Wildl. Manage. Inst., Washington, D.C. 540 pp.
- _____, and R. Crompton. 1972. Nest houses for wood ducks. Ill. Dep. Cons. and Ill. Nat. Hist. Surv. 4 pp.
- Beshears, W. W., Jr. 1974. Wood ducks in Alabama. Ala. Dep. Conserv. Nat. Resour., Spec. Sci. Rep. No. 4. 46 pp.
- Cunningham, E. R. 1969. A three year study of the wood duck on the Yazoo National Wildlife Refuge. Proc. Southeast. Assoc. Game and Fish Comm. 22:145-155.
- Grice, P., and J. P. Rogers. 1965. The wood duck in Massachusetts. Final Rep. Proj. No. W-19-12. Mass. Div. Fish and Game. 96 pp.
- Griffith, M. A., and T. T. Findley. 1981. Five-gallon plastic bucket: An inexpensive wood duck nesting structure. J. Wildl. Manage. 45:281-284.
- Hepp, G. R., and J. D. Hair. 1977. Wood duck brood mobility and utilization of beaver pond habitats. Proc. Southeast. Assoc. Fish and Wildl. Agencies 31:216-225.
- Heusmann, H. W., W. W. Blandin, and R. E. Turner. 1977. Starling-deterrent nesting cylinders in wood duck management. Wildl. Soc. Bull. 5:14-18.
- Johnson, T. W. Undated. Testing the efficaciousness of pinosylvin phenols in repelling rat snakes from wood duck nests. Final Rep., Proj. No. W-37-34. Ga. Game and Fish Div. 13 pp.
- Jones, R. E., and A. S. Leopold. 1967. Nesting interference in a dense population of wood ducks. J. Wildl. Manage. 31:221-228.
- Klein, H. G. 1955. Wood duck production and use of nest boxes. N. Y. Fish and Game J. 2:68-83.
- McGilvrey, F. B. (compiler). 1968. A guide to wood duck production habitat requirements. Bur. Sport. Fish. Wildl. Resour. Publ. 60. 32 pp.
- _____, and F. M. Uhler. 1971. A starling-deterrent wood duck nest box. J. Wildl. Manage. 35:793-797.
- McLaughlin, C. L., and D. Grice. 1952. The effectiveness of large-scale erection of wood duck boxes as a management procedure. Trans. N. Am. Wildl. and Nat. Resour. Conf. 17:242-259.
- Naylor, A. E. 1964. Wood ducks and nest boxes. Calif. Dep. Fish and Game, Game Manage. Leaflet 6. 9 pp.
- Norman, F. I., and T. L. Riggert. 1977. Nest boxes as nest sites for Australian waterfowl. J. Wildl. Manage. 41:643-649.
- Ridlehuber, K. T. 1980. Wood duck production and habitat use. Ph. D. Diss., Tex. A&M Univ., College Station. 43 pp.
- _____. 1982. Fire ant predation on wood duck ducklings and pipped eggs. Southwest. Nat. 27:222.

- USFWS. 1976. Nest boxes for wood ducks. U.S. Fish and Wildl. Serv., Wildl. Leaflet 510. Washington, D.C. 14 pp.
- Webster, C. G., and F. M. Uhler. 1964. Improved nest structures for wood ducks. U.S. Fish and Wildl. Serv., Wildl. Leaflet 458. Washington, D.C. 20 pp.