



**US Army Corps  
of Engineers**®  
Omaha District

# Water Quality Modeling Report

## Simulation of Fort Peck Lake Temperature Releases and Downstream Missouri River Temperatures



**December 9, 2007**



# **Water Quality Modeling Report**

## **Simulation of Fort Peck Lake Temperature Releases and Downstream Missouri River Temperatures**

**Prepared by:**

**Hydrology & Water Control/Water Quality Sections  
Hydrologic Engineering Branch  
Engineering Division  
Omaha District  
U.S. Army Corps of Engineers**

**December 9, 2007**

**For Information Regarding This Document Please Contact:**

Kevin D. Stamm  
U.S. Army Corps of Engineers, Omaha District  
Attention: CENWO-ED-HE  
106 South 15<sup>th</sup> Street  
Omaha, NE 68102-1619  
402-221-4029  
[Kevin.d.stamm@usace.army.mil](mailto:Kevin.d.stamm@usace.army.mil)

## EXECUTIVE SUMMARY

Due to low annual runoff in recent years and low pool levels, the U.S. Army Corps of Engineers was unable to perform a “mini-test” followed by a “full test” of discharge and temperature enhancements to the Missouri River downstream of Fort Peck Lake. In lieu of actual flow and temperature enhancements, the U.S. Army Corps of Engineers, Omaha District performed computer simulations of both Fort Peck Lake and the Missouri River to analyze temperature conditions under flow/temperature enhancement operations.

Temperatures in Fort Peck Lake and the Missouri River downstream of Fort Peck Dam were simulated using CE-QUAL-W2, a two-dimensional (longitudinal and vertical) water quality and hydrodynamic model for rivers, estuaries, lakes, reservoirs, and river basin systems. CE-QUAL-W2 was developed by the Environmental Laboratory at the USACE Engineering Research and Development Center (ERDC) in Vicksburg, MS.

Baseline temperature conditions in the lake and river were developed through simulations of existing data; and, the sensitivity of parameters that influence lake and river temperature including lake inflow and outflow, pool elevation, and environmental temperature was determined. Simulations of spillway releases and selective tower withdrawals were performed to analyze the effectiveness of releasing warm water downstream to the Missouri River in order to meet the 18°C target temperature at Frazer Rapids, MT, as prescribed by the 2000 U.S. Fish and Wildlife Service Biological Opinion.

In the baseline lake simulation 17°C temperatures, sufficient for meeting the 18°C temperature target at Frazer Rapids, MT, arise at the lake surface and spillway crest elevation between June 20 and 22 and persist for 96 days. Lake water near the existing powerhouse intake structure does not reach 17°C during any simulation year. The average simulated Missouri River temperature from June through August was 13.2°C at Frazer Rapids with a peak daily temperature of 17.3°C. In the parameter evaluation, low pool elevations and high environmental temperatures caused higher overall Fort Peck Lake pool and discharge temperatures. Similar sensitivity results were produced in the Missouri River simulations.

During spillway “full tests”, the 18°C water temperature was first achieved at Frazer Rapids, MT, on June 24 meeting the target for 37 days at an average temperature of 18.1°C; however, 0.92 million acre-feet (MAF) of additional water was spilled from the lake. In an alternate spillway release the temperature target was first achieved on June 28 meeting the target for 47 days at an average temperature of 18.2°C over the entire release period with only 0.08 MAF of additional water spilled. Tower withdrawals achieved 18°C temperatures for 70 days when all water was passed through the withdrawal tower inlet near the lake surface, and 18°C temperatures were achieved 37 days when water was passed through both the existing and selective withdrawal tower. Tower withdrawals did not require additional water to be spilled from the reservoir because all water was passed through the powerhouse.



## TABLE OF CONTENTS

---

1	Introduction.....	1
1.1	Purpose of Study.....	1
1.2	Fort Peck Lake.....	1
1.3	Missouri River.....	2
2	Water Temperature Model.....	5
2.1	CE-QUAL-W2.....	5
2.2	Fort Peck Lake Model.....	5
2.2.1	Lake Bathymetry.....	5
2.2.2	Lake Outlet.....	7
2.2.3	Lake Spillway.....	7
2.2.4	Other Model Adjustments.....	9
2.3	Missouri River Model.....	9
2.3.1	River Bathymetry.....	9
2.3.2	River Model Adjustments.....	10
2.4	General Data Sources.....	10
2.4.1	Meteorology.....	10
2.4.2	Lake Inflows, Discharges, and Flow Temperatures.....	11
2.4.3	Missouri River Discharge and Temperature.....	11
2.4.4	Tributary Discharge and Temperature.....	11
2.5	Fort Peck Lake Calibration.....	12
2.5.1	Lake Temperature.....	12
2.5.2	Outlet Temperature.....	12
2.6	Missouri River Calibration Results.....	12
2.6.1	Stage.....	12
2.6.2	Temperature.....	13
2.7	River Temperature Increases.....	13
3	Temperature Analysis under Existing Conditions.....	18
3.1	Lake and Environmental Statistics.....	18
3.2	Lake Temperature Analysis.....	19
3.2.1	Baseline Condition Simulation.....	19
3.2.2	Annual Inflow.....	20
3.2.3	Annual Outflow.....	20
3.2.4	Pool Elevation.....	21
3.2.5	Environmental Temperature.....	21
3.3	Summary of Existing Management.....	22
3.4	River Temperature Analysis.....	33
3.4.1	Typical River Simulation.....	33
3.4.2	Annual Discharge.....	34
3.4.3	Pool Elevation.....	34
3.4.4	Environmental Temperature.....	34
3.5	Summary of River Analysis.....	35
4	Temperature Analysis under Alternative Releases.....	40
4.1	Spillway Releases.....	40
4.1.1	Spillway Full Test.....	40

4.1.2	Alternative Spillway Releases .....	41
4.1.3	Spillway Release Results .....	41
4.2	Selective Withdrawal Releases .....	47
4.2.1	Selective Withdrawal Analysis .....	47
4.2.2	Selective Withdrawal Results .....	48
4.3	Summary of Alternatives .....	54
4.3.1	Lake Performance .....	54
4.3.2	River Temperature Performance.....	55
5	Conclusions.....	57
5.1	Existing Conditions Analysis.....	57
5.2	Alternative Management Analysis.....	57
6	References.....	59
7	Plates.....	60

---



---

### LIST OF TABLES

---



---

Table 1.	Representative segments for the Fort Peck to Culbertson, MT, Missouri River bathymetry. ....	9
Table 2.	Missouri River model location information.....	10
Table 3.	Average Missouri River water temperature increases from Fort Peck Dam to Frazer Rapids and Wolf Point, MT. ....	13
Table 4.	Fort Peck Lake, Milk River, Missouri River, and Glasgow air temperature basic statistics.....	18
Table 5.	Fort Peck Reservoir simulation variations and data years used in the reservoir temperature analysis.....	19
Table 6.	Temperature zone volume/depth analysis of Fort Peck Lake for all existing scenarios.....	22
Table 7.	Time analysis of Fort Peck Lake temperatures at the spillway crest elevation (2225 ft/678.2 m).....	23
Table 8.	Missouri River downstream of Fort Peck - simulations and datasets used in the existing management analysis. ....	33
Table 9.	Summary of average and peak river temperatures on the Missouri River at Frazer Rapids, MT. ....	35
Table 10.	Spillway Full Test and Alternative simulation scenarios. ....	41
Table 11.	Tower selective withdrawal (TW) simulation scenarios. ....	48
Table 12.	Reservoir performance under normal, full test, spillway alternative, and selective withdrawal alternative simulations. ....	54
Table 13.	Missouri River temperature performance at Frazer Rapids, MT, under normal, full test, spillway alternative, and selective withdrawal alternative simulations. ....	55

---



---

### LIST OF FIGURES

---



---

Figure 1.	Fort Peck Lake and water quality sampling locations.....	3
Figure 2.	Missouri River reach model locations.....	4



Figure 3. Area-elevation curves computed from the W2 model bathymetry and the 1986 COE lake survey. ....	6
Figure 4. Volume-elevation curves computed from the W2 model bathymetry and the 1986 COE lake survey. ....	6
Figure 5. Fort Peck Lake outlet works schematic.....	7
Figure 6. Fort Peck Lake gated spillway control structure cross section.....	8
Figure 7. Fort Peck spillway discharge rating curve for 4-open gates.....	8
Figure 8. 2004 USGS measured temperature increases in the Missouri River from Fort Peck Dam to Wolf Point.....	15
Figure 9. 2004 simulated temperature increases in the Missouri River from Fort Peck Dam to Wolf Point.....	15
Figure 10. 2005 USGS measured temperature increases in the Missouri River from Fort Peck Dam to Wolf Point.....	16
Figure 11. 2005 simulated temperature increases in the Missouri River from Fort Peck Dam to Wolf Point.....	16
Figure 12. 2006 USGS measured temperature increases in the Missouri River from Fort Peck Dam to Wolf Point.....	17
Figure 13. 2006 simulated temperature increases in the Missouri River from Fort Peck Dam to Wolf Point.....	17
Figure 14. Baseline simulation temperature profiles at the Fort Peck Lake outlet (L1).....	24
Figure 15. Baseline simulation temperature profiles on July 1. ....	25
Figure 16. Baseline simulation temperature profiles on August 1.....	26
Figure 17. Baseline simulation temperature profiles on September 1.....	27
Figure 18. Baseline Simulation temperatures near the lake surface (1.0-m depth), spillway crest elevation (678.2 m/2225 ft), and powerhouse. ....	28
Figure 19. Simulated Fort Peck Dam release temperatures for three annual inflow scenarios. ...	29
Figure 20. Simulated Fort Peck Lake temperatures near the spillway crest elevation (678.2 m/2225 ft) for three annual inflow scenarios.....	29
Figure 21. Simulated Fort Peck Dam release temperatures for three annual outflow scenarios. ....	30
Figure 22. Simulated Fort Peck Lake temperatures near the spillway crest elevation (678.2 m/2225 ft) for two annual outflow scenarios.....	30
Figure 23. Simulated Fort Peck Dam release temperatures for three pool elevation scenarios... ..	31
Figure 24. Simulated Fort Peck Lake temperatures near the spillway crest elevation (678.2 m/2225 ft) for two annual pool elevation scenarios.....	31
Figure 25. Simulated Fort Peck Dam release temperatures for three environmental temperature scenarios.....	32
Figure 26. Simulated Fort Peck Lake temperatures near the spillway crest elevation (678.2 m/2225 ft) for three environmental temperature scenarios.....	32
Figure 27. Missouri R. Baseline Simulation: Fort Peck Dam, Milk River, and combined discharge (cfs).....	36
Figure 28. Missouri R. Baseline Simulation: Fort Peck Dam, Milk River, and flow-weighted temperatures.....	36
Figure 29. Missouri R. Baseline Simulation: river temperature at Frazer Rapids, Wolf Point, and Culbertson, MT. ....	37
Figure 30. Missouri R. Baseline Simulation: discharge temperature increases from Fort Peck Dam.....	37

Figure 31. Annual Discharge Scenario Simulations: Missouri River temperatures at Frazer Rapids, MT. ....	38
Figure 32. Annual Elevation Scenario Simulations: Missouri River temperatures at Frazer Rapids, MT. ....	38
Figure 33. Environmental Temperature Scenario Simulations Set 1 (identical inflow temperatures): Missouri River temperatures at Frazer Rapids, MT. ....	39
Figure 34. Environmental Temperature Scenario Simulations Set 2 (varied inflow temperatures): Missouri River temperatures at Frazer Rapids, MT. ....	39
Figure 35. Full Test 1: powerhouse and spillway discharge and computed temperature bl Fort Peck Dam. ....	42
Figure 36. Full Test 2: powerhouse and spillway discharge and computed temperature bl Fort Peck Dam. ....	42
Figure 37. Full Test 3: powerhouse and spillway discharge and computed temperature bl Fort Peck Dam. ....	43
Figure 38. Comparison of Full Test simulated river temperatures at Frazer Rapids, MT. ....	43
Figure 39. Spillway Alt 1: powerhouse and spillway discharge and computed temperature bl Fort Peck Dam. ....	45
Figure 40. Spillway Alt 2: powerhouse and spillway discharge and computed temperature bl Fort Peck Dam. ....	45
Figure 41. Spillway Alt 3: powerhouse and spillway discharge and computed temperature bl Fort Peck Dam. ....	46
Figure 42. Comparison of Spillway Alternative simulated river temperatures at Frazer Rapids, MT. ....	46
Figure 43. Typical Fort Peck Lake simulation (1998) temperature time series at three proposed intake levels and the powerhouse intake structure. ....	47
Figure 44. Tower and total powerhouse discharge and Fort Peck Dam discharge temperature for TW1. ....	50
Figure 45. Tower and total powerhouse discharge and Fort Peck Dam discharge temperature for TW2. ....	50
Figure 46. Tower and total powerhouse discharge and Fort Peck Dam discharge temperature for TW3. ....	51
Figure 47. Tower Withdrawal Alternative (Elev. 680 m) simulated river temperatures at Frazer Rapids, MT. ....	51
Figure 48. Tower and total powerhouse discharge and Fort Peck Dam discharge temperature for TW4. ....	52
Figure 49. Tower and total powerhouse discharge and Fort Peck Dam discharge temperature for TW5. ....	52
Figure 50. Tower and total powerhouse discharge and Fort Peck Dam discharge temperature for TW6. ....	53
Figure 51. Tower Withdrawal Alternative (Elev. 670 m) simulated river temperatures at Frazer Rapids, MT. ....	53

## LIST OF PLATES

---

Plate 1. 2004 Glasgow International Airport (KGGW) hourly air and dew point temperature Celsius.....	61
Plate 2. 2004 Glasgow International Airport (KGGW) hourly wind speed (m/s).....	61
Plate 3. 2005 Glasgow International Airport (KGGW) hourly air and dew point temperature...	62
Plate 4. 2005 Glasgow International Airport (KGGW) hourly wind speed (m/s).....	62
Plate 5. 2006 Glasgow International Airport (KGGW) hourly air and dew point temperature...	63
Plate 6. 2006 Glasgow International Airport (KGGW) hourly wind speed (m/s).....	63
Plate 7. 2004 Fort Peck Lake inflows.....	64
Plate 8. 2005 Fort Peck Lake inflows.....	64
Plate 9. 2006 Fort Peck Lake inflows.....	65
Plate 10. Fort Peck Lake inflow temperatures on the Missouri River at Landusky (2004-2006) and assumed tributary temperatures.....	65
Plate 11. 2004 Missouri & Milk River discharge downstream of Fort Peck Reservoir.....	66
Plate 12. 2005 Missouri & Milk River discharge downstream of Fort Peck Reservoir.....	66
Plate 13. 2006 Missouri & Milk River discharge downstream of Fort Peck Reservoir.....	67
Plate 14. 2004 Fort Peck Dam & Milk River discharge temperatures.....	68
Plate 15. 2005 Fort Peck Dam & Milk River discharge temperatures.....	68
Plate 16. 2006 Fort Peck Dam & Milk River discharge temperatures.....	69
Plate 17. Fort Peck Lake observed and simulated lake elevations from 2004 to 2006.....	70
Plate 18. 2004 measured and simulated water temperature profiles at L1 (0 km from the dam) in the Missouri River arm.....	71
Plate 19. 2004 measured and simulated water temperature profiles at L2 (10 km from the dam) in the Missouri River arm.....	72
Plate 20. 2004 measured and simulated water temperature profiles at L3 (25 km from the dam) in the Missouri River arm.....	73
Plate 21. 2004 measured and simulated water temperature profiles at L4 (50 km from the dam) in the Missouri River arm.....	74
Plate 22. 2004 measured and simulated water temperature profiles at L5 in the Big Dry arm..	75
Plate 23. 2004 measured and simulated water temperature profiles at L6 in the Big Dry arm..	76
Plate 24. 2005 measured and simulated water temperature profiles at L1 (0 km from the dam) in the Missouri River arm.....	77
Plate 25. 2005 measured and simulated water temperature profiles at L2 (10 km from the dam) in the Missouri River arm.....	78
Plate 26. 2005 measured and simulated water temperature profiles at L3 (25 km from the dam) in the Missouri River arm.....	79
Plate 27. 2005 measured and simulated water temperature profiles at L4 (50 km from the dam) in the Missouri River arm.....	80
Plate 28. 2005 measured and simulated water temperature profiles at L5 in the Big Dry arm..	81
Plate 29. 2005 measured and simulated water temperature profiles at L6 in the Big Dry arm..	82
Plate 30. 2006 measured and simulated water temperature profiles at L1 (0 km from the dam) in the Missouri River arm.....	83
Plate 31. 2006 measured and simulated water temperature profiles at L2 (10 km from the dam) in the Missouri River arm.....	84

Plate 32. 2006 measured and simulated water temperature profiles at L3 (25 km from the dam) in the Missouri River arm. ....	85
Plate 33. 2006 measured and simulated water temperature profiles at L4 (50 km from the dam) in the Missouri River arm. ....	86
Plate 34. 2006 measured and simulated water temperature profiles at L5 in the Big Dry arm. ..	87
Plate 35. 2006 measured and simulated water temperature profiles at L6 in the Big Dry arm. ..	88
Plate 36. 2004 observed and simulated Fort Peck dam release temperatures.....	89
Plate 37. 2005 observed and simulated Fort Peck dam release temperatures.....	89
Plate 38. 2006 observed and simulated Fort Peck dam release temperatures.....	90
Plate 39. 2004 Missouri River calibrated river stage at Wolf Point, MT gage (W2 Location 129.5 km). ....	91
Plate 40. 2005 Missouri River calibrated river stage at Wolf Point, MT gage (W2 Location 129.5 km). ....	91
Plate 41. 2006 Missouri River calibrated river stage at Wolf Point, MT gage (W2 Location 129.5 km). ....	92
Plate 42. 2004 Missouri River simulated water temperatures calibrated to measured water temperatures.....	93
Plate 43. 2005 Missouri River simulated water temperatures calibrated to measured water temperatures.....	94
Plate 44. 2006 Missouri River simulated water temperatures calibrated to measured water temperatures.....	95
Plate 45. Fort Peck Lake average annual lake elevation and statistics. ....	96
Plate 46. Fort Peck Lake average annual lake inflow and statistics. ....	96
Plate 47. Fort Peck Lake average annual lake outflow and statistics. ....	97
Plate 48. Milk River at Nashua, MT, annual discharge and statistics. ....	97
Plate 49. Missouri River at Culbertson, MT, annual discharge and statistics. ....	98
Plate 50. Glasgow, MT, International Airport average annual temperature (°C) and statistics... ..	98





# 1 INTRODUCTION

## 1.1 Purpose of Study

In November 2000 the U.S. Fish and Wildlife Service (USFWS) released the Biological Opinion of the Operation of the Missouri River Main Stem Reservoir System recommending Missouri River flow and temperature enhancements downstream of Fort Peck Dam to improve environmental conditions for the endangered pallid sturgeon. Flow enhancements by releasing water through the Fort Peck Lake spillway were scheduled to be performed once every three years when the lake pool elevation was above 679.7 meters (2,230 feet) and annual runoff was at the Median, Upper Quartile, or Upper Decile level; however, pool and runoff levels have been insufficient to perform a “mini-test” for gathering data and a “full test” of improved flow and temperature enhancements.

In lieu of actual flow and temperature enhancements, the U.S. Army Corps of Engineers, Omaha District is performing computer simulations of both Fort Peck Lake and the Missouri River to analyze temperature conditions in Fort Peck Lake and the Missouri River downstream of Fort Peck. The following objectives will be carried out within the Hydrology Section of the Hydrologic Engineering Branch, Engineering Division in the Omaha District of the U.S. Army Corps of Engineers:

- 1) Using CE-QUAL-W2 develop calibrated water temperature computer models of Fort Peck Lake and the Missouri River from Fort Peck Dam to Culbertson, MT. The models will be calibrated to water temperature data collected from 2004 to 2006.
- 2) Study factors that influence lake and river temperatures including lake inflow and outflow volumes, lake elevation, environmental temperatures and river flow volumes. Develop relationships between the factors and the impacts, and develop a baseline reservoir and river temperature condition.
- 3) Analyze the effectiveness of warm water release methods to enhance river temperatures in order to meet the 18°C target temperature at Frazer Rapids, MT, as prescribed by the USFWS Biological Opinion.

This report documents the development of calibrated water temperature models using the Corps of Engineers QUAL-W2 computer model and the analysis of influencing factors and lake releases to meet USFWS goals. Conclusions of this study are based primarily on water temperature and lake performance. Other factors that may influence warm water release decisions will be addressed in subsequent studies.

## 1.2 Fort Peck Lake

Fort Peck Lake is formed by the impoundment of the Missouri River by Fort Peck Dam at River Mile 1,771.5 (2,851 km), 18 miles (29 kilometers) southeast of Glasgow, MT, and approximately 10 miles (16.1 km) upstream of the Missouri River confluence with the Milk River. The total drainage area above Fort Peck Dam is 57,725 mi<sup>2</sup> (149,507 km<sup>2</sup>). The dam is 250 feet (76 meters) high and 4 miles (6.4 km) long. The multipurpose pool elevation is 2,234 ft (680.9 m) and the flood control pool is 2,250 ft (685.8 m). The average pool level from 1967 to 1997 was 2,234.9 ft (681.2 m) with a standard deviation of 9.8 ft (2.99 m). The average daily

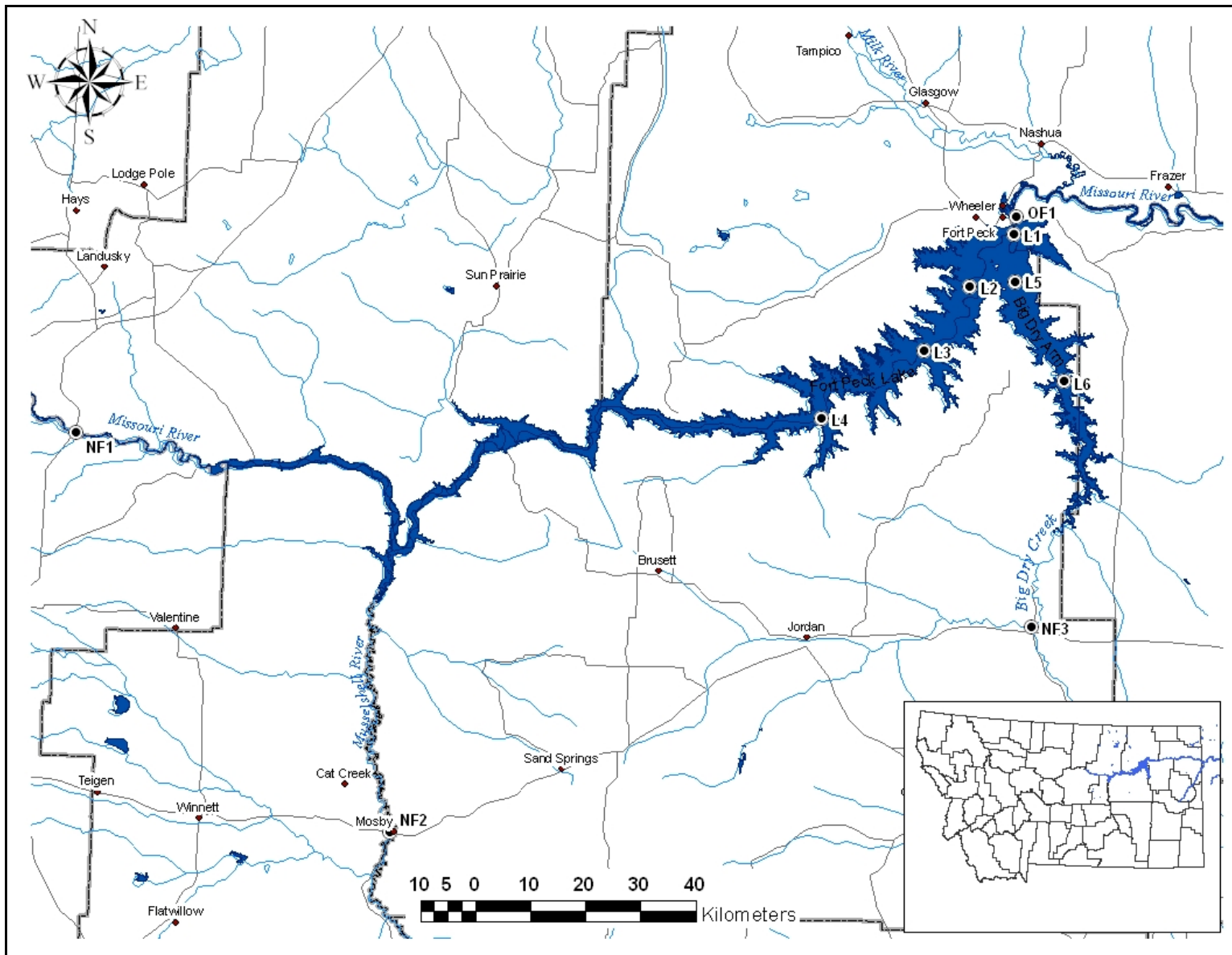
release is 10,200 cubic feet per second (cfs) (289 cubic meters per second) with a standard deviation of 3,900 cfs (110 cms). Storage at the multipurpose pool elevation is 15.2 million acre-feet ( $18,760 \times 10^6 \text{ m}^3$ ), and the residence time is approximately 2.06 years.

Fort Peck Lake is composed of two main lake branches, the main branch formed by the Missouri River channel, and the second branch formed by Big Dry Creek extending south-southeast from the dam. The Missouri River is the major inflow, and the Musselshell River and Big Dry Creek are minor tributary inflows into the lake.

### **1.3 Missouri River**

The Missouri River extends from the outlet of Fort Peck Reservoir at River Mile 1,772.5 (2,852.6 km) to the inlet of Lake Sakakawea near Williston, ND, at River Mile 1,552.5 (2,498.5 km). Since the river is highly regulated by Fort Peck Dam, monthly mean discharges range from a low of 8,790 cfs (248.9 cms) in March to a high of 11,800 cfs (334.1 cms) in August. The Milk River is a major tributary entering the Missouri River 10 mi (16.1 km) downstream of Fort Peck Dam and contributing  $22,332 \text{ mi}^2$  ( $57,840 \text{ km}^2$ ) of drainage area at Nashua, MT. The total drainage contributing to the Missouri River at the mouth of the Milk River is approximately  $80,060 \text{ mi}^2$  ( $207,354 \text{ km}^2$ ). Monthly mean discharges range from a low of 144 cfs (4.1 cms) in January to a high of 2,120 cfs (60 cms) in April. Several important locations along the river include the Fort Peck Dam spillway chute at RM 1,762 (2,835.7 km), Frazer Rapids at RM 1,746 (2,809.9 km), Wolf Point stream gage at RM 1,701.5 (2,738.3 km) Culbertson stream gage at RM 1,621 (2,608.7 km), and the Yellowstone River mouth RM 1,577 (2,537.9 km). The CE-QUAL-W2 model used in this study extends from Fort Peck Dam to Culbertson, MT.





**Figure 1. Fort Peck Lake and water quality sampling locations.**

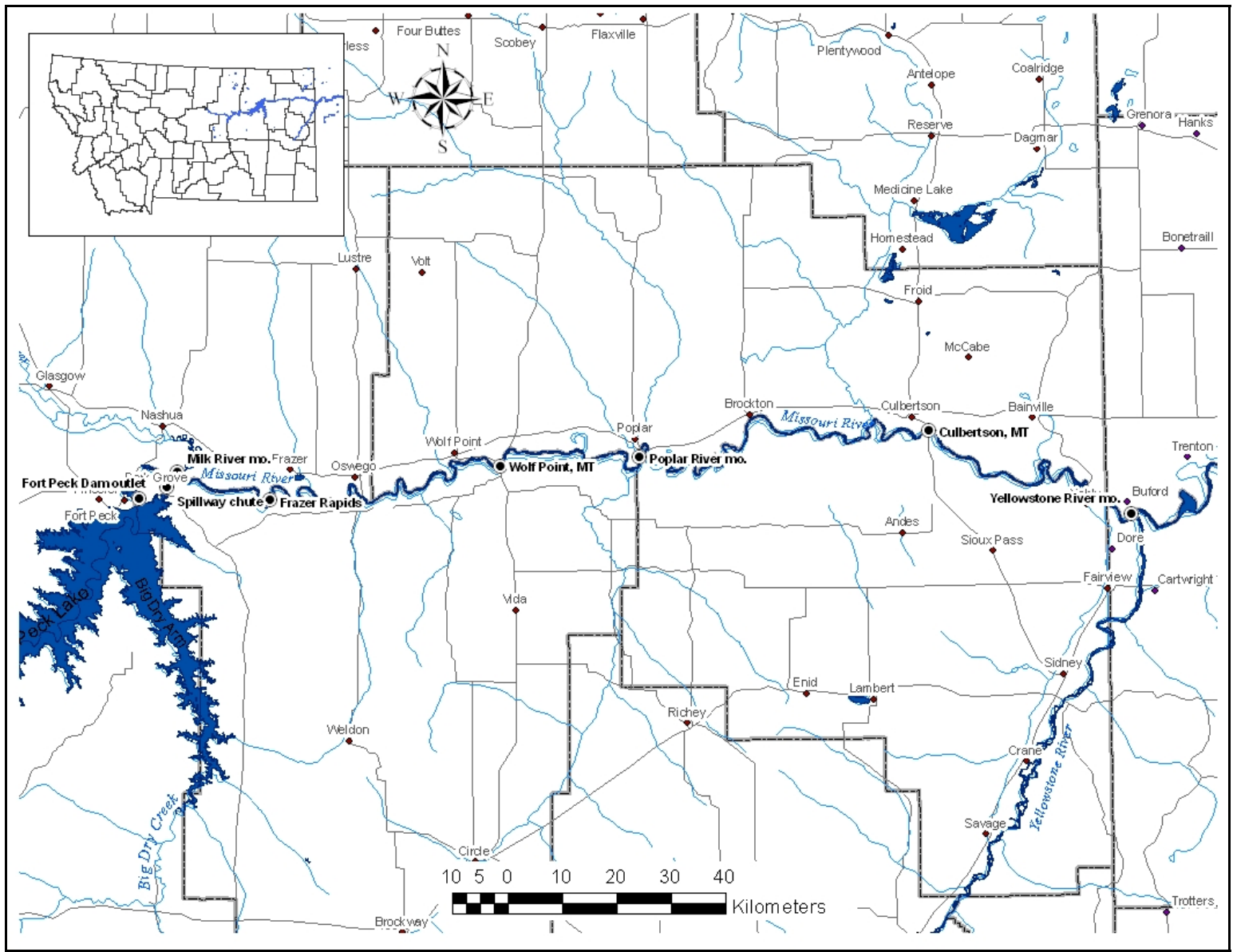


Figure 2. Missouri River reach model locations.

## 2 WATER TEMPERATURE MODEL

### 2.1 CE-QUAL-W2

CE-QUAL-W2 is a two-dimensional (longitudinal and vertical) water quality and hydrodynamic model for rivers, estuaries, lakes, reservoirs, and river basin systems. CE-QUAL-W2 simulates basic physical, chemical, and biological processes such as temperature, nutrient, algae, dissolved oxygen, organic matter, and sediment relationships. The current model release is Version 3.2 and is supported by the Environmental Lab at the USACE Engineering Research and Development Center (ERDC) in Vicksburg, MS, and Portland State University.

Version 2.0 of the CE-QUAL-W2 model was applied to four of the upper Mainstem System Projects in the early 1990s (i.e., Ft. Peck Lake, Lake Sakakawea, Lake Oahe, and Lake Francis Case). The application of the model was part of the supporting technical documentation of the Environmental Impact Statement (EIS) that was prepared for the Missouri River Master Water Control Manual Review and Update Study. The results of the model application were included as an Appendix to the Review and Update Study – “Volume 7B: Environmental Studies, Reservoir Fisheries, Appendix C – Coldwater Habitat Model, Temperature and Dissolved Oxygen Simulations for the Upper Missouri River Reservoirs” (Cole et. al., 1994).

The current version of the model (3.2) will be applied to Fort Peck Reservoir and the Missouri River downstream of the dam to Culbertson, MT. Predicted temperatures in the lake and river models will be influenced by reservoir inflow volumes and temperatures; environmental factors such as wind, air temperature, and solar radiation; and management factors such as reservoir release rates and outflow structure configurations. Ongoing modeling is being performed under the guidance of Dr. Mark Dortch of the Environmental Lab of ERDC.

### 2.2 Fort Peck Lake Model

#### 2.2.1 Lake Bathymetry

The Fort Peck Lake bathymetry was modified from previous CE-QUAL-W2 bathymetry used in the Coldwater Habitat Model constructed by Cole et al. (1994) of the U.S. Army Corps of Engineers Waterways Experiment Station in Vicksburg, MS. The reservoir bathymetry consisted of two main branches, 45 active segments and 32 layers. Segments were 5 km (3.1 mi) in length with 2 m (6.56 ft) layer thicknesses. At the multipurpose pool level, segment widths ranged from 11,500 m (37,700 ft) at the dam to 800 m (2,625 ft) at the lake inlet. Segment orientations were adjusted to match their correct geographic orientation. Chezy’s bottom friction coefficients were set to 100. Volume-area-elevation curves constructed from the Corps of Engineers survey and computed from model bathymetry are compared in Figures 3 and 4.

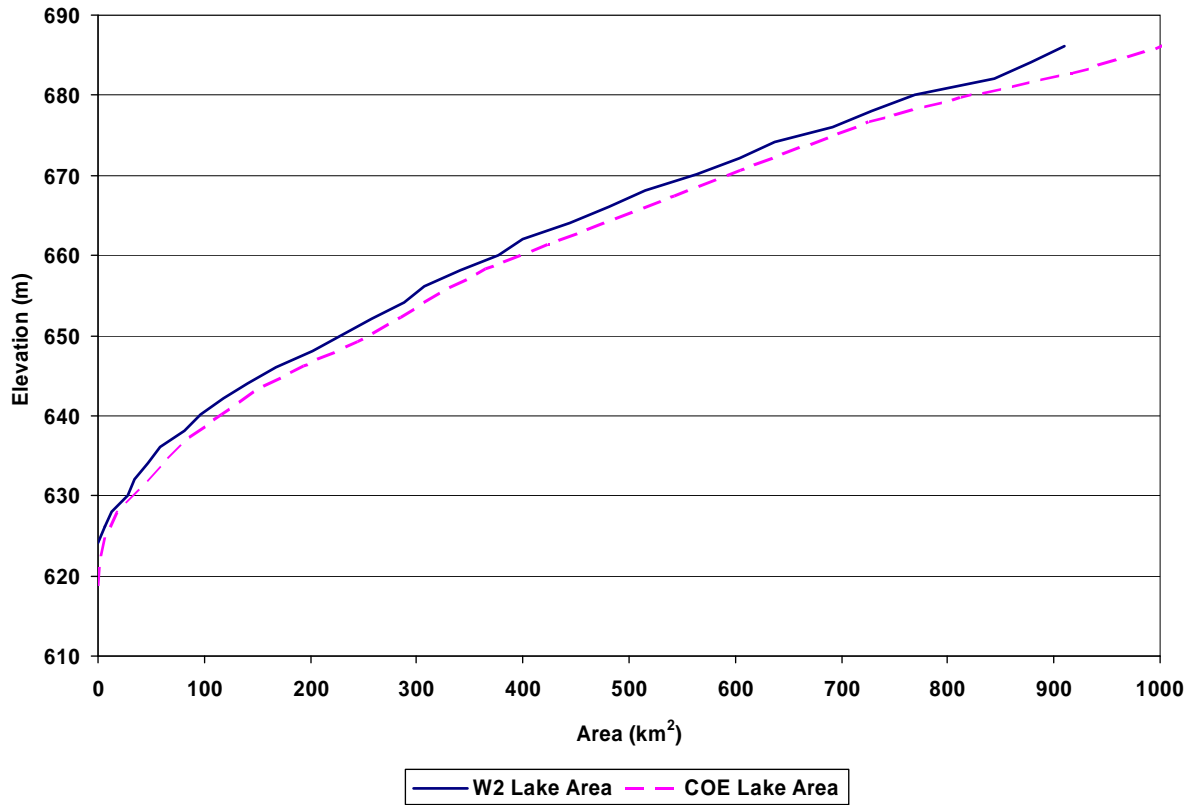


Figure 3. Area-elevation curves computed from the W2 model bathymetry and the 1986 COE lake survey.

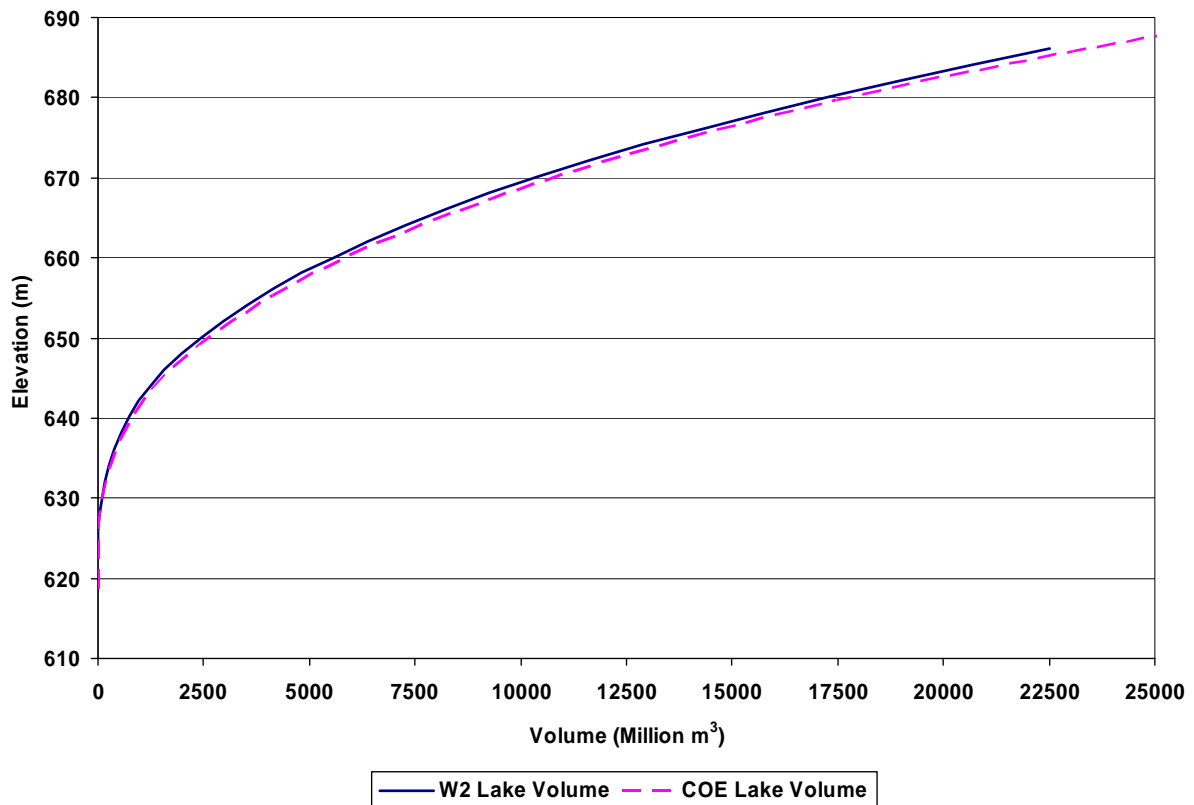


Figure 4. Volume-elevation curves computed from the W2 model bathymetry and the 1986 COE lake survey.

### 2.2.2 Lake Outlet

The Fort Peck Lake outlet works consists of reservoir inlet portal connected to four tunnels controlled at the dam axis by control shafts. Below the control shafts, two of the tunnels connect to Powerhouses No. 1 and 2, while the third and fourth tunnels outlet directly to the Missouri River. The inlet portal is 157.7 m (517.5 ft) long, 17.4 m (57 ft) wide, and 19.8 m (65 ft) in height. The crest of the inlet portal is at elevation 638.6 m (2,095 ft) and the top of the trash rack is at elevation 644.8 (2,115.5 ft). Figure 5 is a schematic diagram of the intake portal and intake tunnels. Additionally, the minimum multi-purpose pool elevation is 658.4 m (2,160 ft), the maximum normal operation pool is 684.6 m (2,246 ft), and the maximum operating pool is 685.8 m (2,250 ft).

The outlet configuration for the model was set up initially with an intake elevation of 638.6 m (2,095 ft), an inlet bottom limit at Layer 34 or elevation 622.1 m (2,041 ft), and an inlet top limit at Layer 2 or the upper reservoir limit. Calibration of the parameter revealed that the model computed more accurate dam discharge temperatures using an intake elevation of 641.7 m (2,105.3 ft) and an inlet bottom limit at Layer 27 or elevation 636.1 m (2,086.9 ft). Computed outlet temperature results varied by year, yet the calibrated inlet parameters fit all years relatively well.

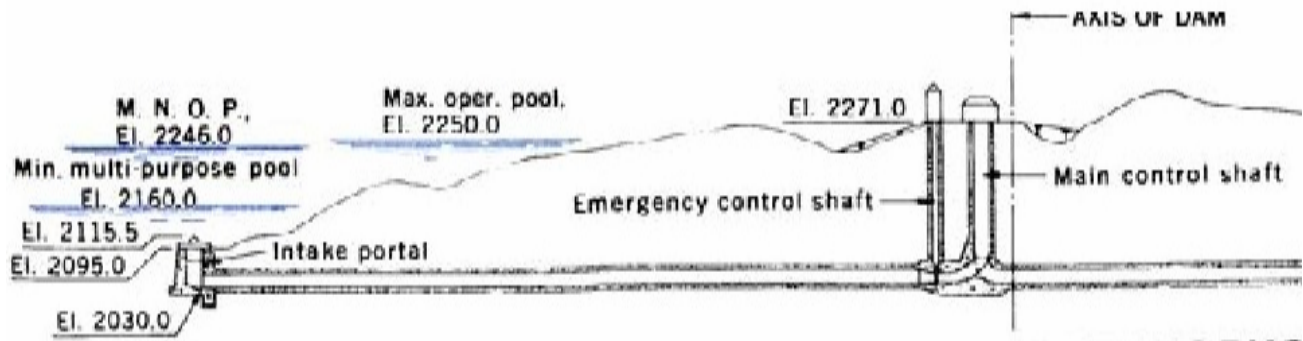


Figure 5. Fort Peck Lake outlet works schematic.

### 2.2.3 Lake Spillway

The Fort Peck Lake spillway is located about 4.8 km (3.0 mi) east of Fort Peck Dam and it consists of an approach channel, a gated control structure, and a concrete-lined channel approximately 1,463 m (4,800-ft) long. The control structure has 16 vertical lift gates, 7.62 m (25-ft) high by 12.2 m (40-ft) wide, which may be lifted individually or together. The crest elevation of the spillway at the gates is 678.2 m (2,225 ft), and the gates may be lifted 7.62 m (25 ft). A schematic of the control tower is shown in Figure 6. Discharge through the spillway is a function of the number of gates open, the pool elevation or head behind the gates, and the height of the gate opening. The gate opening may be raised to a height of 7.62 m (25 ft) to elevation 685.8 m (2,250 ft) which is the maximum operating pool. Discharges are limited to the free-flowing weir discharge when the bottom of the gate is above the water surface elevation or the full opening position. The spillway discharge rating curve for four gate openings is provided in Figure 7. The spillway will only be operated during high pool elevations or when warm water releases are needed to enhance Missouri River temperatures.

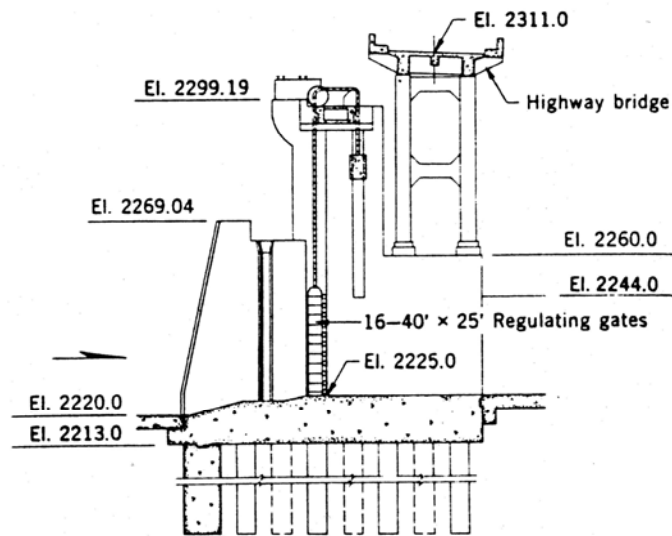


Figure 6. Fort Peck Lake gated spillway control structure cross section.

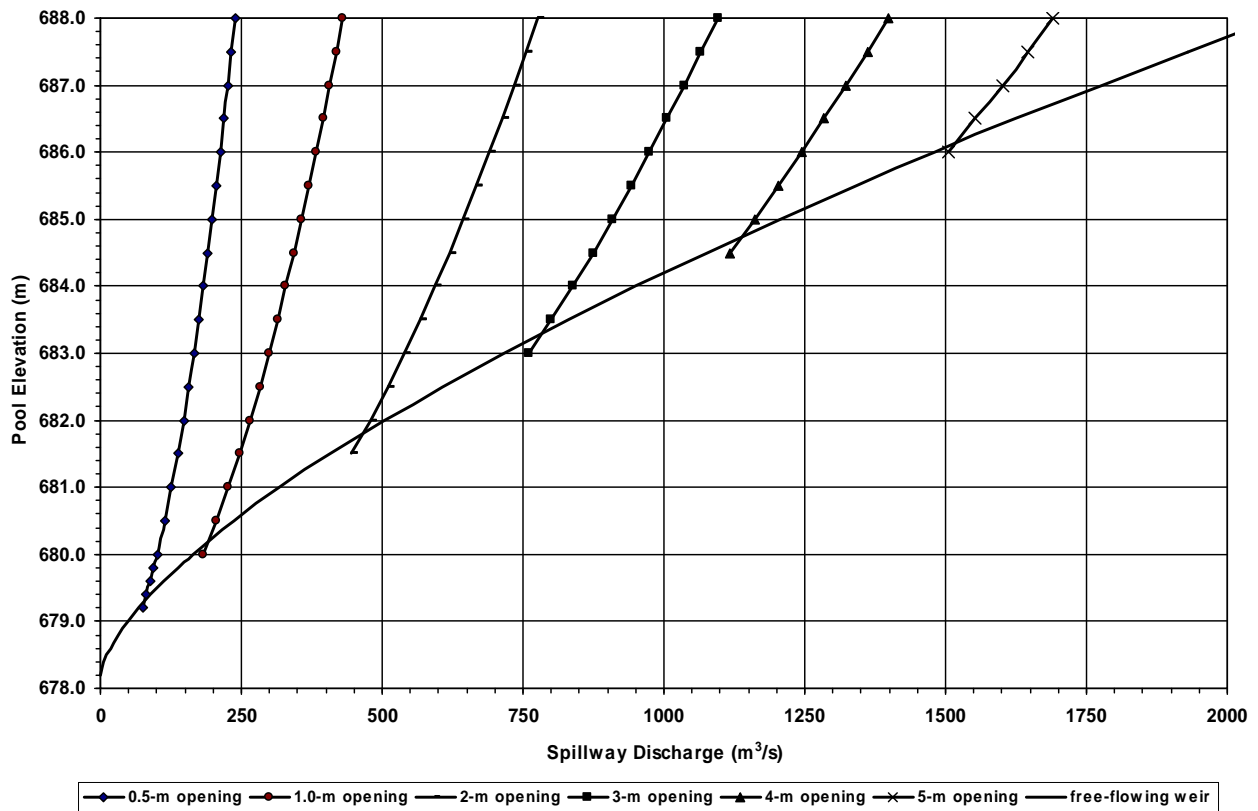


Figure 7. Fort Peck spillway discharge rating curve for 4-open gates.

## 2.2.4 Other Model Adjustments

The lake model computed temperatures best using the turbulent kinetic energy (TKE) method for vertical eddy viscosity. In addition, the model performed best using the Term-by-Term rather than the Equilibrium Temperature Method.

## 2.3 Missouri River Model

### 2.3.1 River Bathymetry

New bathymetry was constructed for a 240-km (149.1-mi) reach extending from Fort Peck Reservoir to Culbertson, MT, based on an HEC-RAS hydraulic river model for the Missouri River. Cross sections for the HEC-RAS model were surveyed during a 1988 Corps of Engineers sediment range survey of the Missouri River. It was assumed that the river channel was fairly uniform; however, bathymetry segments representing five different cross sections were created for the 240-km river reach to account for variations in channel cross sections. Table 1 summarizes the five representative cross sections in their CE-QUAL-W2 bathymetry format. The model uses 98, 2,500-m (8,202-ft) long segments. The most upstream and downstream segments are boundary layer segments, so they are not used to actively compute water quality.

The channel bottom elevation over the 240-km reach was computed based on an adjusted channel bottom elevation of 572.05 m NGVD29 (1876.80 ft NGVD29) at Wolf Point, MT, and a uniform slope of 0.00018 m/m.

The Manning's roughness coefficient of 0.028 for the entire model reach was determined during model calibration by eye-fitting the simulated stages at Wolf Point, MT, to observed stages at the Wolf Point USGS stream gage.

**Table 1. Representative segments for the Fort Peck to Culbertson, MT, Missouri River bathymetry.**

Upstream Station, mi (km)	240 (1770.1)	175 (1729.7)	120 (1695.6)	80 (1670.7)	27.5 (1638.1)
Downstream Station, mi (km)	175 (1729.7)	120 (1695.6)	80 (1670.7)	27.5 (1638.1)	0.0 (1621)
Stage (meters)	Layer Width (meters)				
7.5	445	654	594	610	654
7.0	440	532	538	594	532
6.5	420	411	490	538	411
6.0	400	350	434	490	350
5.5	380	319	383	434	326
5.0	354	317	383	367	289
4.5	334	315	381	306	264
4.0	329	313	380	261	253
3.5	320	294	375	250	232
3.0	309	244	313	229	214
2.5	293	211	248	197	174
2.0	263	202	178	128	115
1.5	130	155	115	92	80
1.0	99	109	73	59	48
0.5	57	57	36	29	24
0.0	0	0	0	0	0

The model is constructed in SI units for Missouri River in which locations are generally referenced in river miles. Several important locations along the Missouri River within this model include the Fort Peck Dam outlet; Frazer, MT; Wolf Point, MT; and Culbertson, MT. Table 2 provides location names with corresponding river miles, model bathymetry stations in kilometers, and model bathymetry segments numbers.

**Table 2. Missouri River model location information.**

Location Name	River Station (miles)	Bathymetry Station (km)	Bathymetry Segment No.
Fort Peck Dam Outlet (assumed location)	1770	240.0	2
below Fort Peck Dam, observed temperature	1765	231.7	5
Fort Peck Spillway Chute & Milk River mouth	1762	226.9	7
Frazer Rapids, MT, observed temperature	1746	201.2	17
Wolf Point, MT	1701.5	129.5	46
Poplar River mouth	1679	93.3	60
Culbertson, MT	1621	0	97

### 2.3.2 River Model Adjustments

River stage was calibrated to observed stages at Wolf Point, MT, by adjusting the river channel bottom and the Manning’s roughness coefficient. River channel bottom at Wolf Point was set to an elevation of 572.1 m and all other elevations were determined based on a channel slope of 0.00018 m/m. The roughness coefficient was adjusted from 0.024 to 0.028 to achieve the desired river stage.

The vertical diffusion of momentum is a very important process within the model that determines the degree of vertical mixing in the river model. Vertical diffusion can be controlled by several parameters in the model including the method for computing vertical eddy viscosity. The CE-QUAL-W2 user manual recommended that all methods besides the W2, renormalization group (RNG), and the turbulent kinetic energy (TKE) methods could be used effectively for computing vertical eddy viscosity; however, information in the modeling clinic indicated the W2 method would be appropriated for riverine models. The Nickuradse (NICK) method was initially used resulting in a mildly stratified temperature profile; however, USGS findings indicated that the temperature profile was homeo-thermic. Consequently the W2N method generated a well-mixed, homeo-thermic profile; therefore, it was adopted as the vertical eddy viscosity method.

## 2.4 General Data Sources

### 2.4.1 Meteorology

Hourly weather data was obtained from the National Climatic Data Center Local Climatological Data online database for all simulation years. The Wokal Field/Glasgow International Airport (GGW) weather station maintained by the airport and the National Weather Service (NWS) provided hourly air temperature, dew point temperature, wind speed, wind direction, and cloud cover. The station coordinates are 48°12’N latitude, 106°37’W longitude, at a ground elevation of 691.3 m (2268 ft). Wind speed and direction were measured at a 10 meter height. Cloud cover reported qualitatively was converted to a cloud quantity required by the CE-QUAL-W2 program in computing incident solar radiation. Cloud cover is quantified on a scale



of 0 to 10, 10 being the greatest amount of cloud cover. The cloud cover quantities that worked best in the Fort Peck Reservoir and Missouri River simulations were two (2) for clear conditions (CLR) and scattered cloud cover (SCT), six (6) for few (FEW) clouds, eight (8) for broken cover (BKN), and ten (10) for overcast (OVC) days.

Wind sheltering is an important adjustment factor used to reduce wind shear forces at the water surface. In the lake model wind sheltering coefficients were set at 90% of measured wind speed to account for the reduction in wind speed from the measuring location to the lake surface. In the riverine model wind sheltering coefficients were set at 80% to reduce wind due to higher terrain surrounding the river.

Hourly air temperature, dew point temperature, and wind speed for simulation years 2004-2006 are plotted in Plates 1 – 6.

#### 2.4.2 Lake Inflows, Discharges, and Flow Temperatures

The Missouri River, Musselshell River, and Big Dry Creek were the sources of Fort Peck Lake inflows. Missouri River daily streamflow and average daily temperature served as the main inflow to Branch 1. This data was measured by the USGS stream gage at Landusky, MT (Gage no. 06115200). The Musselshell River and Big Dry Creek were minor inflows into Fort Peck Lake. Musselshell River streamflow measured by the USGS at Mosby, MT (Gage no. 06130500) served as a tributary inflow near the lake inlet. Big Dry Creek streamflow measured by the USGS at Van Norman, MT (Gage no. 06131000) served as the Branch 2 inflow. Model inflows are plotted for the calibration years 2004 through 2006 in Plates 7 - 9. Partial year daily temperature data was available at Landusky in 2004 and 2005, while hourly temperature data was available in 2006. Temperature measurements were not made from 2004 to 2006 on the Musselshell River and Big Dry Creek, so a 1978 temperature dataset of Big Dry Creek was used in place of real temperature measurements on the two minor inflows. Inflow temperature data is plotted in Plate 10.

#### 2.4.3 Missouri River Discharge and Temperature

Fort Peck Dam outflow is the main discharge and contributor of thermal energy into the Missouri River CE-QUAL-W2 model. Discharge and temperature data was provided on a daily and hourly time-step by the Corps of Engineers, Omaha District Water Control Section database. Outflow temperatures were measured in the raw water loop in Powerplant No. 2 on an hourly basis with a Hydrolab temperature probe from 2004 to the present. Simulated dam release temperatures calibrated to the measured release temperatures were used in the river simulations.

The USGS maintains stream gages at Wolf Point (Gage no. 06177000) and Culbertson, MT (Gage no. 06185500), which provides daily stage, discharge, and mean temperature. Wolf Point served as a discharge, stage, and temperature calibration point; and, Culbertson served as the boundary condition location for downstream discharge, stage, and temperature. Discharges from Fort Peck Dam and Missouri River discharges at Culbertson, MT, are shown in Plates 11 - 13. Fort Peck Dam and Milk River discharge temperatures are shown in Plates 14 - 16.

#### 2.4.4 Tributary Discharge and Temperature

The Milk River, Poplar River, and Big Muddy Creek are tributaries that enter the Missouri River in the reach extending from Fort Peck Lake to Culbertson, MT. Poplar River and Big Muddy Creek stream flows during the 2004 to 2006 calibration period were insignificant, so

they were not incorporated into the model. The Milk River contributes significant stream flows during wet years, so it was used in all simulation years.

Milk River stage and temperature is measured at Nashua, MT, by the USGS. The Milk River empties into the Missouri River at RM 1762 or model station 226.9 km. Daily temperatures have been recorded on a regular basis by the USGS from May 17 to October 9 since 2001. Year 2000 temperature data was used during the remainder of the calendar year dates. Milk River discharges are shown in Plates 11 - 13, and temperatures are shown in Plates 14 - 16.

## **2.5 Fort Peck Lake Calibration**

The water balance routine was used to perform the balance by accounting for deficits and surpluses that caused deviations from the observed water surface elevation. In each of the calibration years (2004 – 2006), a close fit to observed elevations was achieved (Plate 17).

Water column temperatures in the lake model were calibrated to observed water column temperatures at four locations in the Missouri River branch of Fort Peck and two locations in the Big Dry Creek branch (Big Dry Arm) of Fort Peck. Observed temperatures were measured with Hydrolab probes during the sampling season.

Modeled outlet temperatures were calibrated to hourly Fort Peck Dam powerhouse release temperatures. Release temperatures were measured with a Hydrolab probe inserted into a container receiving water from the powerhouse raw water loop.

### **2.5.1 Lake Temperature**

Lake temperatures are plotted for simulations in 2004, 2005, and 2006 in Plates 18 - 35. Temperature profiles correspond to sampling locations L1, L2, L3, and L4 at distances of 0 km, 10 km, 25 km, and 50 km from the dam in the Missouri River branch; and, locations L5 and L6 at distances of 0 km and 20 km from the downstream boundary of the Big Dry Creek branch. Measured temperature profile dates are included in each profile plot.

The calibrated model provides a relatively good fit to the measured temperature profile data, though the profiles exhibit some deviation especially near the lake bottom. Root-mean-squared (RMS) errors computed for each profile are also provided in the plots. RMS error average over 2004, 2005, and 2006 simulation years were 0.665, 0.945, and 0.846, respectively.

### **2.5.2 Outlet Temperature**

Simulated outlet temperatures plotted against measured outlet temperatures in the Fort Peck powerhouse are shown in Plates 36 - 38. Since warm water releases are desired during the warm season, calibration targeted temperatures from April through September. The model produced a generally good fit during all years, and perhaps the best temperature fit during the 2005 simulation (Plate 37).

## **2.6 Missouri River Calibration Results**

### **2.6.1 Stage**

Simulated river stage at Wolf Point, MT (Loc 129.5 km) is plotted in Plates 39 - 41. CE-QUAL-W2 computed stages to within 0.1 – 0.2 meters of observed stage during the free flowing/non-ice affected seasons, while during the ice-affected season, it underestimated the

simulated stage. Ice-affected observed stages are depicted as gray symbols. CE-QUAL-W2's computational strength is in two-dimensional water quality modeling, and so it stands to reason that it may not compute stage affected by ice cover and ice jam accurately.

## 2.6.2 Temperature

After adjustments were made to the vertical momentum method and bathymetry, temperature calibrated to observed data very well. Plates 42 - 44 are time series plots of simulated river temperature and observed temperature below Fort Peck Dam (Loc 231.7 km), at Frazer (Loc 201.2 km), at Wolf Point (Loc 129.5 km), and at Culbertson (Loc 0) from Julian days 50 to 300. Temperatures are reported only at the one-meter depth because the water column profile was well-mixed creating a homo-thermic temperature profile. In all three calibration years (2004 – 2006) a majority of the simulated temperatures appeared to be within 0.5 to 1.0°C, and better at most time steps. Some error is probably present due to the inadequacy of Milk River temperature data.

## 2.7 River Temperature Increases

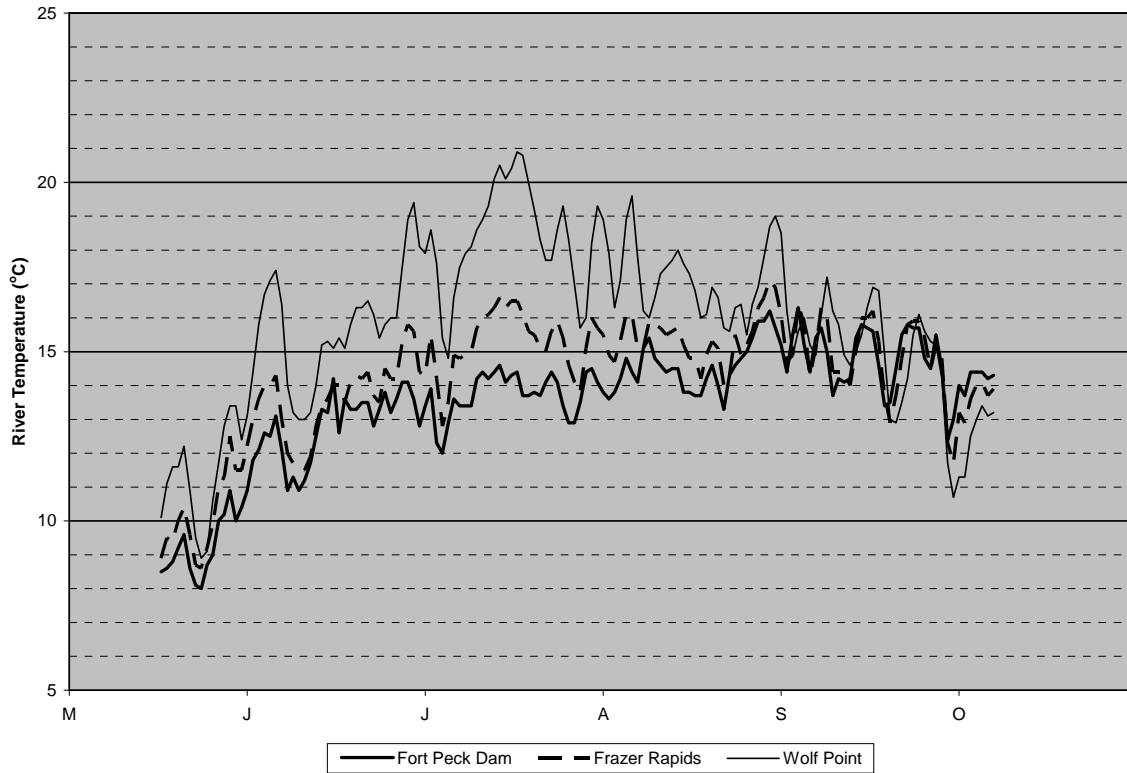
Missouri River water undergoes natural temperature increases from the outlet of Fort Peck Dam throughout the Missouri River channel downstream to Lake Sakakawea in North Dakota. Temperature increases are caused primarily solar insolation of the cooler Fort Peck Lake water as it flows downstream. The greatest temperature increases occur during maximum solar insolation during the summer months. A conservative estimate of warming from Fort Peck Dam to Frazer Rapids was determined using calibrated model data and USGS observed temperatures.

Temperature increases from Fort Peck Dam to Frazer Rapids were evaluated during the 2004-2006 simulation and observation years. The USGS measured daily temperatures in the river at numerous locations from May 17 to October 9 of each year from 2001 to 2007. Plots of simulated and measured daily temperatures in 2004, 2005, and 2006 are provided in Figures 8 - 13. Both plots demonstrate the river temperature increases that occur from Fort Peck Dam to Frazer Rapids to Wolf Point, MT. Average temperature increases are compared during the May 17 to October 9 time period in Table 3. Simulated average seasonal temperature increases at both Frazer Rapids and Wolf Point were higher than measured average seasonal temperature increases; however, differences were less than 0.5°C. A conservative estimate of average temperature increase from Fort Peck Dam to Frazer Rapids throughout the simulation/observing season is 1.25°C or roughly the average of the simulated and measured temperature increases. At Wolf Point, average temperature increases ranging from about 2.5 to 3.5°C occurred in the simulated data and 2.4 to 3.3°C occurred in the measured data. Temperature increases during the warmest part of the season may range from 7.0 to 11.0°C, while during the cool seasons, temperatures decrease after being released from the reservoir.

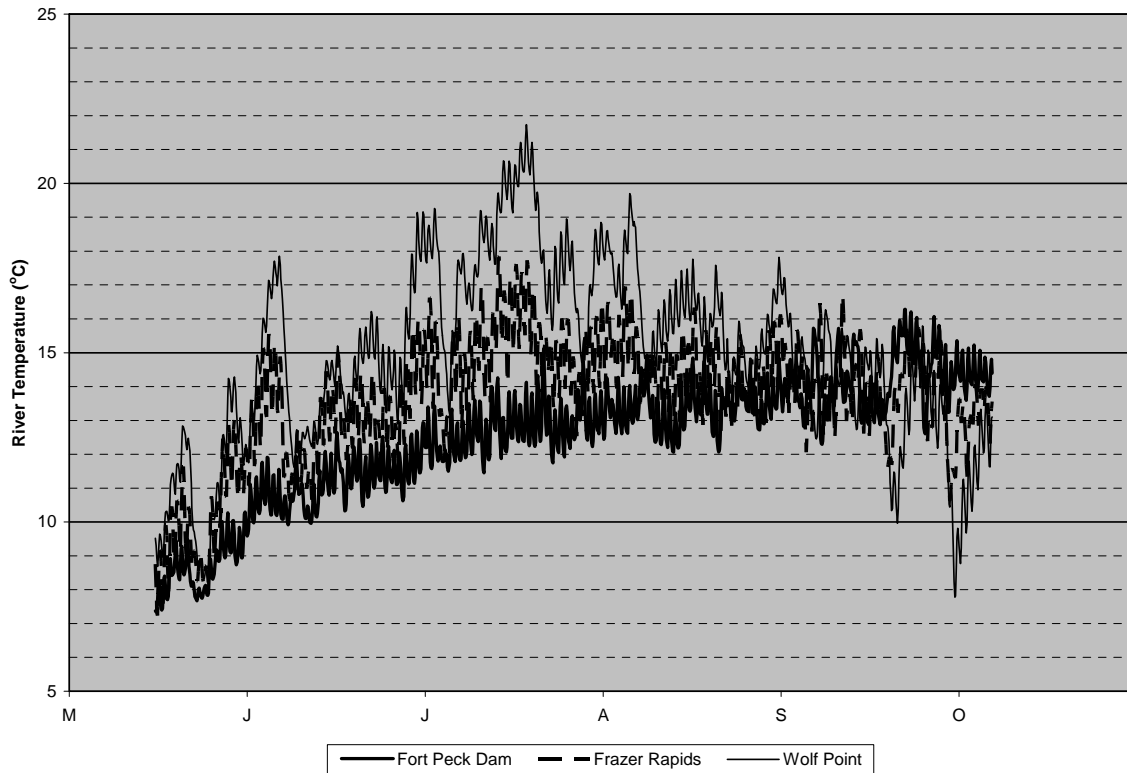
**Table 3. Average Missouri River water temperature increases from Fort Peck Dam to Frazer Rapids and Wolf Point, MT.**

	Frazer Rapids		Wolf Point	
	Simulated	Measured	Simulated	Measured
2004	1.20	0.77	2.55	2.43
2005	1.57	1.35	3.15	3.33
2006	1.51	1.24	3.49	3.25
Average	1.43	1.12	3.06	3.00

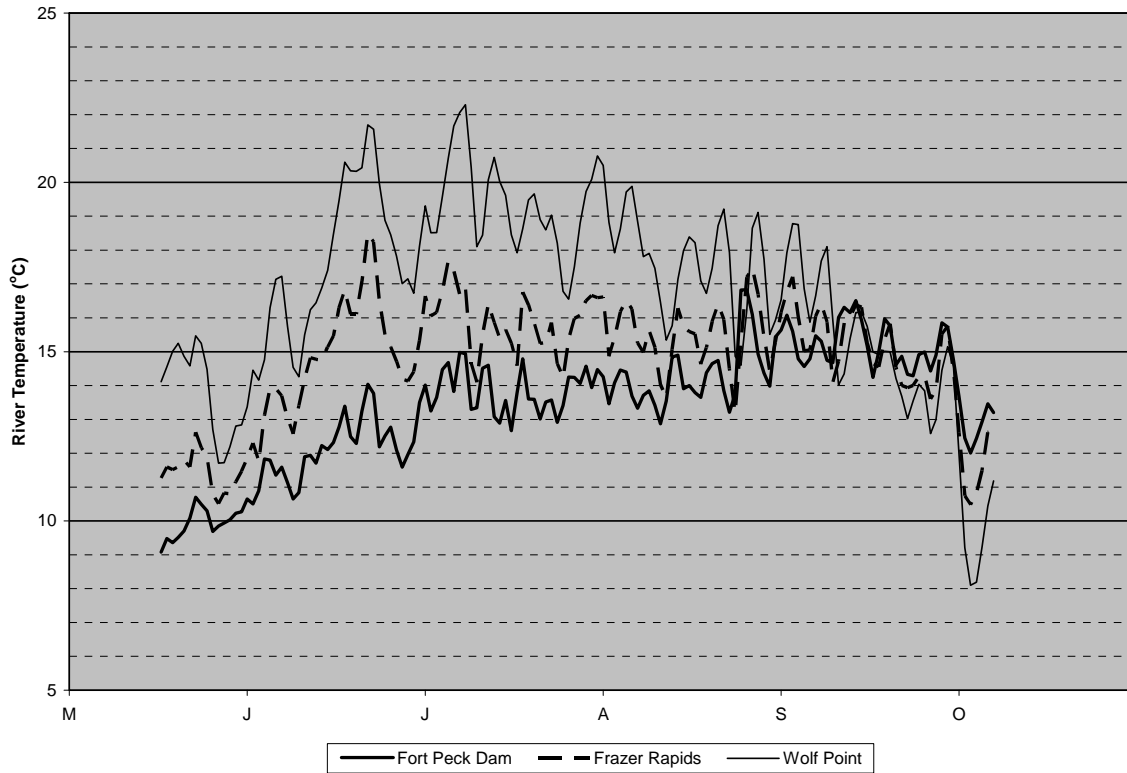
The target temperature during the pallid sturgeon spawning season is 18°C at Frazer Rapids near Frazer, MT, approximately 26.5 miles (42.6 km) kilometers downstream of Fort Peck Dam, and 24.9 miles (40 km) from the upstream model boundary. Since the average seasonal temperature increase from Fort Peck Dam to Frazer Rapids is 1.25°C according to the evaluated data, water with a minimum temperature of 17.0 (16.75)°C should be released from the reservoir in order to meet the Frazer Rapids target temperature.



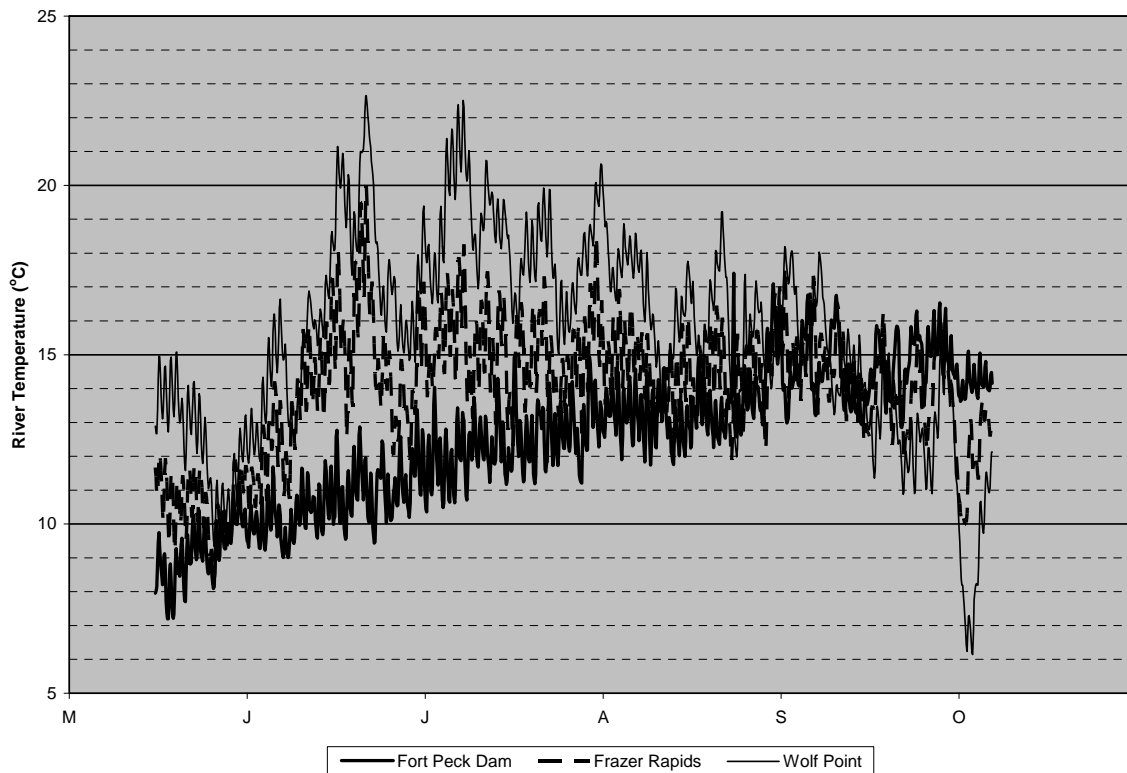
**Figure 8. 2004 USGS measured temperature increases in the Missouri River from Fort Peck Dam to Wolf Point.**



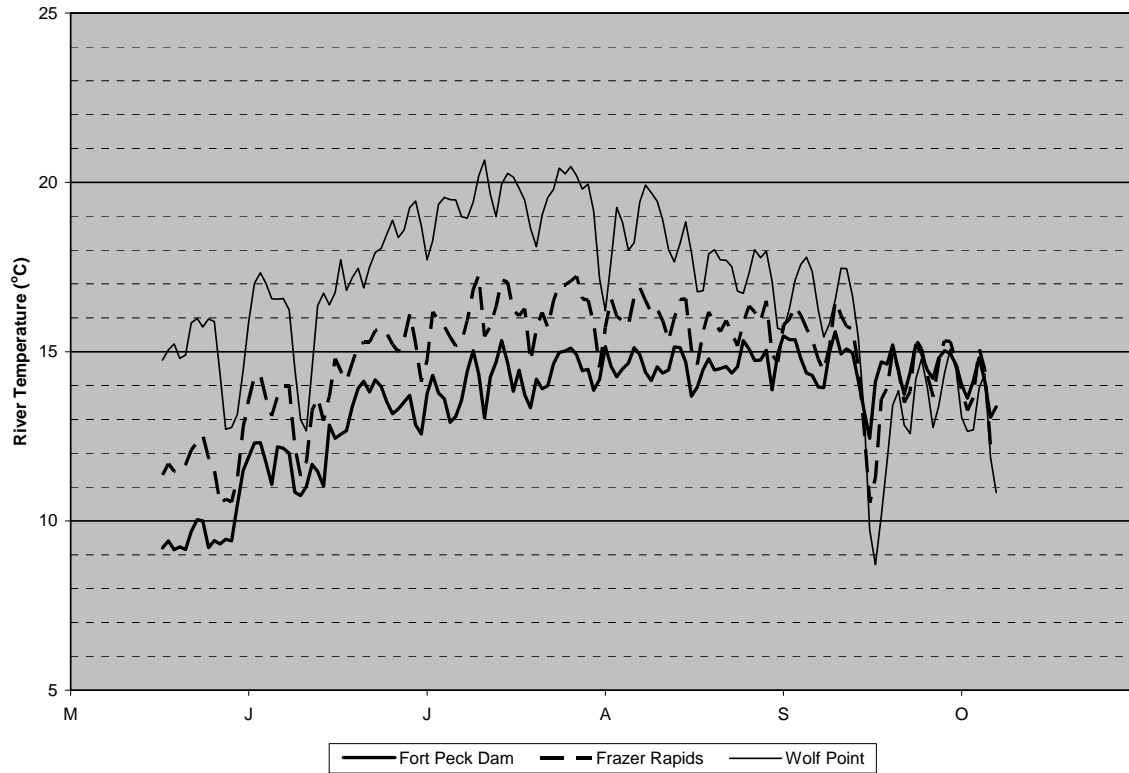
**Figure 9. 2004 simulated temperature increases in the Missouri River from Fort Peck Dam to Wolf Point.**



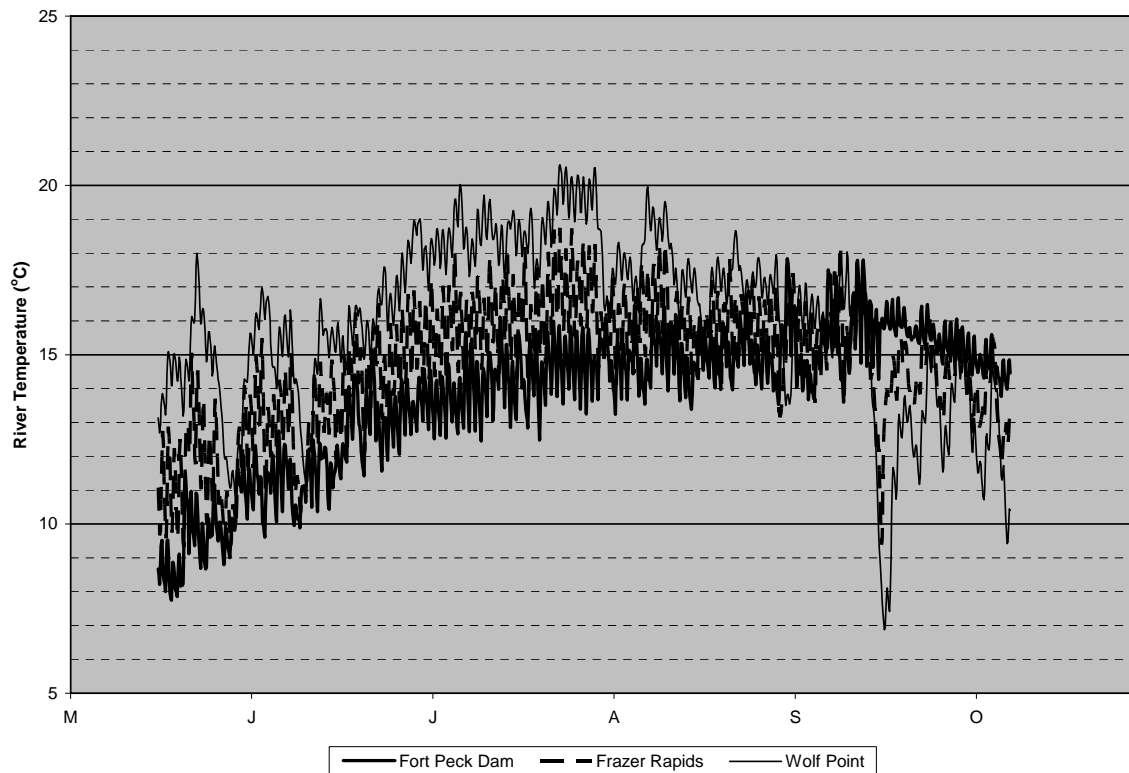
**Figure 10. 2005 USGS measured temperature increases in the Missouri River from Fort Peck Dam to Wolf Point.**



**Figure 11. 2005 simulated temperature increases in the Missouri River from Fort Peck Dam to Wolf Point.**



**Figure 12. 2006 USGS measured temperature increases in the Missouri River from Fort Peck Dam to Wolf Point.**



**Figure 13. 2006 simulated temperature increases in the Missouri River from Fort Peck Dam to Wolf Point.**

### 3 TEMPERATURE ANALYSIS UNDER EXISTING CONDITIONS

In order to gain an understanding of existing temperature conditions in Fort Peck Lake and the Missouri River downstream of Fort Peck Dam, CE-QUAL-W2 simulations of existing dam operational and environmental conditions were performed. Simulations of Fort Peck Lake and the Missouri River downstream during a normal operating and meteorological year were used to establish a baseline lake and river temperature conditions. Furthermore, simulations evaluated the impact that lake inflow, lake outflow, pool elevation and environmental temperatures have on lake and downstream Missouri river temperatures. Development of a baseline model and evaluation of controlling factors was an important step in assessing the time and volume availability of warm water (greater than 17 – 18°C) in the lake for potential release to the Missouri River.

#### 3.1 Lake and Environmental Statistics

Statistics including mean, median, maximum, minimum, 10<sup>th</sup>, 25<sup>th</sup>, 75<sup>th</sup>, and 90<sup>th</sup> percentiles were developed for hydrodynamic and environmental factors that will be evaluated in the lake and river simulations. Hydrodynamic factors included annual lake inflow, outflow, pool elevation, Milk River discharge at Nashua, MT, and Missouri River discharge at Culbertson, MT. The lone environmental factor evaluated was Glasgow International Airport annual temperature. Statistics were calculated to establish normal and abnormally low and high hydrodynamic and environmental years based on the factors listed. Data years that are characteristic of the median, 10<sup>th</sup> and 90<sup>th</sup> percentile statistics will be chosen for simulation. The calculated statistics are provided in Table 4. Based on the period of record analyzed, Fort Peck Lake median pool elevation was 679.9 m (2,230.6 ft), median annual inflow was 281.9 cms (9,955 cfs), and median annual outflow was 253.1 cms (8,938 cfs). Median annual air temperature computed from Glasgow International Airport records was 5.89°C (42.6°F). The complete period of record of annualized flow information and temperature are shown in Plates 45 - 50 at the end of this report.

**Table 4. Fort Peck Lake, Milk River, Missouri River, and Glasgow input parameter basic statistics.**

Statistic	----- Fort Peck Lake -----			Milk River Annual Discharge	Missouri River at Culbertson Annual Discharge	Glasgow International Airport Annual Temperature
	Annual Pool Elevation	Annual Inflow	Annual Outflow			
	m	m <sup>3</sup> /s	m <sup>3</sup> /s	m <sup>3</sup> /s	m <sup>3</sup> /s	°C
Mean	678.1	283.6	260.1	17.9	285	5.89
Median	679.9	281.9	253.1	14.1	277	5.89
Maximum	684.2	529.6	451.3	65.8	494	8.61
Minimum	662.7	149.1	140.4	1.5	89	3.44
10 <sup>th</sup> Percentile	671.2	183.2	173.6	4.0	185	4.33
25 <sup>th</sup> Percentile	674.8	219.7	204.6	7.2	224	5.11
75 <sup>th</sup> Percentile	682.4	343.9	312.3	24.7	357	6.78
90 <sup>th</sup> Percentile	683.1	386.0	355.8	37.1	409	7.33
Record Start	1943	1943	1943	1941	1941	1956
Record End	2006	2006	2006	2005	2005	2005
Record Length	64	64	64	65	59	50



### 3.2 Lake Temperature Analysis

CE-QUAL-W2 simulations of lake temperature were performed using a combination of varied lake hydrodynamics and meteorological conditions. Three variations of the each analysis parameter which included a median year, 90<sup>th</sup> and 10<sup>th</sup> percentile year were chosen for simulation. Hydrodynamic data was grouped by calendar year in order to ensure that the lake water budget balanced. Combinations of hydrodynamics and meteorology are summarized in Table 5. Temperatures and timing of warm water near the Fort Peck spillway and temperatures at the intake structure depth were specifically addressed in the following analysis.

**Table 5. Fort Peck Reservoir simulation variations and data years used in the reservoir temperature analysis.**

Analysis Parameter	Variation	Hydrodynamic Year	Meteorological Year
Baseline Condition		1998	1994
Annual Inflow	90 <sup>th</sup> percentile	1982	
	Median	1998	1994
	10 <sup>th</sup> percentile	1988	
Annual Outflow	90 <sup>th</sup> percentile	1979	
	Median	1998	1994
	10 <sup>th</sup> percentile	2002	
Pool Elevation	90 <sup>th</sup> percentile	1997	
	Median	1988	1994
	10 <sup>th</sup> percentile	2004	
Air Temperatures	90 <sup>th</sup> percentile		1998
	Median	1998	2000
	10 <sup>th</sup> percentile		2004

#### 3.2.1 Baseline Condition Simulation

The baseline condition simulation was performed using 1998 hydrodynamic data and 1994 meteorological data. During the 1998 calendar year, the Fort Peck pool elevation averaged 681.9 m (2237.1 ft), the average annual inflow was 285.4 cms (10,080 cfs), and the average annual outflow was 252 m (8,900 cfs), both near their respective median values. The average annual temperature during the 1994 meteorological year was near the 5.9°C (42.6°F) median temperature at Glasgow, MT, International Airport.

Lake temperature profiles in the main branch of Fort Peck Lake near the dam are plotted in Figure 14. Temperatures warm gradually from early spring through the summer, reaching peak temperatures at the surface in mid-August, and then eventually cooling until fall when temperatures become isothermal in October. At the elevation of the powerhouse intake well (638.6 m/2,095 ft) temperatures warm from about 4°C (39.2°F) to 10.1°C (52.0°F) by September 1 (Figure 14). The 17°C (62.6°F) isotherm on September 1 was at elevation 662.0 m (2171.9 ft) or 23.4 m (76.9 ft) above the intake elevation. In this particular simulation near the dam, temperatures exceed 17°C in the top 20 meters near the end of June, in July, August, and the first few weeks of September.

Simulated temperatures throughout the reservoir from July through September behave similarly in response to wind and temperature inputs, which have the greatest influence on lake temperatures in the lacustrine zone or main body of the lake. Figures 15 – 17 are simulated temperature profiles at the six sampling locations shown in Figure 1. Locations L1, L2, L3, and

L5 are all within the lacustrine zone of the reservoir, while L4 is in a transitional zone, and L5 is in the Big Dry Arm in a shallow water location. On July 1 (Figure 15) temperatures show some separation, especially at L1 which may be caused by the lower level outlet drawing a portion of the cold water out of that zone of the reservoir. L5 is similar in temperature to L2 and L3 on July 1, August 1 (Figure 16) and September 1 (Figure 17). On August 1, L4 temperatures in the transitional zone are warmer near the surface due to warmer Missouri River inflows and possibly some vertical mixing in the top 15 to 20 meters. In general, temperatures are similar in the main branch of Fort Peck Lake and the Big Dry Arm with the exception of the shallower, up-lake areas.

Time series of lake temperature 1.0-m below the lake surface, at the spillway crest elevation 678.2 m (2225 ft) and in water discharged through the powerhouse are plotted in Figure 18. Temperatures at the spillway outlet reach 17°C on June 22 and persist until September 27, while temperatures near the lake surface equal or exceed 17°C during that same time period. Powerhouse release temperatures ranged from 5.0°C (41°F) on May 1 to 13.0°C (55.4°F). Temperatures remained at about 13.0°C until cooling of the surface and turnover forced warmer water deeper into the reservoir near the end of September resulting in outlet temperatures of about 14°C (57.2°F). The baseline simulation demonstrates that 17-18°C water sufficient to meet the BiOp temperature criteria at Frazer Rapids is present in the reservoir for several months near the surface; however, it cannot be released through the powerhouse in its existing configuration in a typical year.

### 3.2.2 Annual Inflow

The three annual lake inflow or volume scenarios were evaluated while holding the meteorological data constant. The three scenarios represent the 90<sup>th</sup> percentile of inflow (1982), median inflow (1998), and the 10<sup>th</sup> percentile of inflow (1988). Lake inflow temperature data at Landusky, MT, and van Norman, MT was not recorded during the simulation dataset years, so inflow temperatures synthesized from 2004 and 2005 were used in these simulations and all subsequent simulations in the absence of actual inflow temperatures.

Based on the plot of dam release temperature in Figure 19, it appears the annual lake inflow or volume does not have a major impact on dam discharge temperature. Simulated outflow temperatures ranged from about 12 to 14°C from mid-July through September, then reached a maximum of about 15°C at lake turnover in early October. Also annual inflow variations do not have a major impact on lake temperatures near the spillway crest elevation (Figure 20).

### 3.2.3 Annual Outflow

The three annual lake outflow scenarios were evaluated while holding the meteorological data constant. The three scenarios represented the 90<sup>th</sup> percentile of outflow (1979), median outflow (1998), and the 10<sup>th</sup> percentile of outflow (2002).

Based on the plot of dam release temperature in Figure 21, the 10<sup>th</sup> percentile outflow year produced about 2°C higher discharge temperatures than both the 90<sup>th</sup> percentile outflow and median outflow years, which were similar to outflow temperatures simulated in the annual inflow scenarios. This may be explained by the lower pool elevation (676.1 m/2218.3 ft) of the 10<sup>th</sup> percentile outflow year (2002) compared to the higher pool elevations in the median (1998) and 90<sup>th</sup> percentile (1979) years which were 681.9m (2237.1 ft) and 683.9 m (2243.9 ft),

respectively. Lower pool elevations allow the thermocline, which is the transition zone between cooler hypolimnion temperatures and warmer epilimnion temperatures, to push to lower elevations in the reservoir closer to the powerhouse intake structure at elevation 638.6 m (2095.0 ft). Temperatures in the 10<sup>th</sup> percentile year simulation reached maximums of about 16.5°C at lake turnover from late September to early October.

At the spillway crest elevation median outflow scenario temperatures were also slightly warmer than high outflow scenario temperatures (Figure 22). The pool elevation in the low outflow scenario fell below the spillway crest elevation; therefore, lake temperatures at the spillway elevation crest were not computed.

#### 3.2.4 Pool Elevation

The three average annual pool elevation scenarios were evaluated while holding the meteorological data constant. The three years represented the 90<sup>th</sup> percentile pool (1997), median pool (1988), and the 10<sup>th</sup> percentile pool (2004).

In the plot of dam release temperature in Figure 23, the 10<sup>th</sup> percentile outflow scenario (2004) produced 2 to 3°C higher discharge temperatures than both the 90<sup>th</sup> percentile outflow and median outflow scenarios, which were similar to outflow temperatures in the previous two scenarios. Average annual pool elevations were 683.1 m (2241.3 ft), 679.4 m (2229.1 ft), and 671.4 m (2202.7 ft) for the 90<sup>th</sup> percentile, median, and 10<sup>th</sup> percentile scenarios, respectively. The bottom of the simulated thermoclines on August 16 (jday = 228) were 645.6 m (2118.1 ft), 644.0 m (2112.8 ft), and 638.3 m (2094.2 ft) for the 90<sup>th</sup> percentile, median, and 10<sup>th</sup> percentile scenarios respectively. The lake outlet in the simulations is defined at elevation 641.7 m (2105.3 ft), so only the 10<sup>th</sup> percentile thermocline was below the outlet elevation. This explains why the 10<sup>th</sup> percentile outlet temperatures were warmer than the 90<sup>th</sup> percentile and median temperatures, which were quite similar because water below the thermocline is moderately isothermal. In general it appears that pool elevation impacts dam release temperature the most when elevations are below the median elevation.

At the spillway crest elevation, median elevation scenario temperatures were slightly warmer than high elevation scenario temperatures (Figure 24). The pool elevation in the low elevation scenario was below the spillway crest elevation; therefore, lake temperatures at the spillway crest elevation were not computed.

#### 3.2.5 Environmental Temperature

Three average environmental temperature scenarios were evaluated using 1998 inflow/outflow/ elevation data. The scenarios were represented by the 90<sup>th</sup> percentile temperature conditions (1998), the median temperature condition (2000), and the 10<sup>th</sup> percentile temperature condition (2004).

In the plot of dam release temperature in Figure 25, the 90<sup>th</sup> percentile temperature scenario (1998) produced 2 to 3°C higher outflow temperatures than both the 10<sup>th</sup> percentile outflow and median outflow scenarios, which were similar to outflow temperatures in the previous three scenarios. The 90<sup>th</sup> percentile scenario (1998) was one of the five warmest years since 1943 at the Glasgow, MT International Airport. Since lake hydrodynamics were the same in all three simulations, it appears that high environmental temperatures are needed to drive the thermocline deeper into the reservoir.

At the spillway crest elevation lake temperatures were directly related to environmental temperatures, with high environmental temperatures producing the warmest lake temperatures (Figure 26). High environmental temperatures also lengthened the period of time that water temperatures remained warm in Fort Peck Lake.

### 3.3 Summary of Existing Management

Of the four parameters evaluated in the existing lake management analysis, low pool elevation and high environmental air temperatures produced higher lake outflow temperatures than the other parameter conditions. Low annual outflow also produced higher lake outflow temperatures, but largely as a result of low annual pool elevations.

Provided that Fort Peck release water will increase in temperature at least 1°C from the dam to Frazer Rapids, at least 17°C water must be released from the reservoir to meet the 18°C requirement. For the Baseline Simulation and each analysis parameter scenario, the volumes of water meeting the minimum 17°C requirement and the location of the 17°C isotherm were summarized in Table 6. In the Baseline Simulation, a maximum of 11.6 million acre feet (MAF) or 76.7 % of the lake water generally in the metalimnion and epilimnion will meet the temperature requirement on about September 19. On that date the 17°C isotherm was at elevation 659.1 m (2162.4 ft), 20.5 m (67.4 ft) above the crest of the outlet structure and at a depth from the surface of 23.3 m (76.5 ft). Volumes of water meeting the criteria and elevations of the isotherm varied in the analysis, and generally the isotherm came closest to the outlet at lower pool elevations and in warm environmental conditions.

**Table 6. Temperature zone volume/depth analysis of Fort Peck Lake for all existing scenarios.**

Analysis Parameter	Date of Maximum Volume > 17°C	Reservoir Volume MAF	Zone Volume Temperature > 17°C		Water Surface Elevation (ft)	17°C Isotherm nr Intake Structure & Spillway Bay	
			Maximum Volume MAF	% of Reservoir Volume		Elevation (ft) †	Depth (ft)
Baseline Simulation	Sept. 19	15.1	11.6	76.7	2238.9	2162.4	76.5
Annual Inflow							
90 <sup>th</sup> percentile	Sept. 20	15.5	11.9	76.7	2238.7	2162.4	76.3
Median	Sept. 19	15.6	11.8	75.6	2238.9	2160.4	78.5
10 <sup>th</sup> percentile	Sept. 17	13.1	9.6	73.2	2226.5	2145.6	80.9
Annual Outflow							
90 <sup>th</sup> percentile	Sept. 19	16.5	12.2	73.9	2243.1	2168.0	75.1
Median	Sept. 19	15.6	11.8	75.6	2238.9	2160.4	78.5
10 <sup>th</sup> percentile	Sept. 19	11.5	9.7	84.5	2217.8	2133.5	84.3
Pool Elevation							
90 <sup>th</sup> percentile	Sept. 19	17.0	13.0	76.4	2245.5	2160.1	85.4
Median	Sept. 18	13.1	9.6	73.6	2226.6	2148.9	77.7
10 <sup>th</sup> percentile	Sept. 9	8.7	7.3	84.1	2200.2	2131.9	68.3
Air Temperatures							
90 <sup>th</sup> percentile	Sept. 19	15.6	11.6	74.6	2238.9	2158.4	80.5
Median	Sept. 9	15.6	11.0	70.9	2238.9	2155.2	83.7
10 <sup>th</sup> percentile	Sept. 7	15.6	10.5	67.2	2238.9	2165.0	73.9

† Top of intake structure at elevation 2095 ft.

Warm water release of 17 – 18°C from the spillway is an alternative in consideration for augmenting temperatures downstream of Fort Peck Dam. A time analysis of Fort Peck Lake temperatures near the spillway crest elevation was performed to determine probable dates and the length of time that warm water was present near the spillway crest elevation of 678.2 m (2225 ft). Both 17 and 18°C temperatures were evaluated individually in order to construct a maximum (17°C) range of dates given the 1°C temperature increase and a probable (18°C) range of dates that warm water was present at the spillway crest. The results are summarized in Table 7.

**Table 7. Time analysis of Fort Peck Lake temperatures at the spillway crest elevation (2225 ft/678.2 m).**

	First Date of 17°C	Last Date of 17°C	Number of Days	First Date of 18°C	Last Date of 18°C	Number of Days
Baseline Simulation	June 22	September 26	96	June 24	September 15	83
Annual Inflow						
90 <sup>th</sup> percentile	June 21	September 26	97	June 24	September 15	83
Median	June 23	September 25	94	June 24	September 15	83
10 <sup>th</sup> percentile	June 21	September 24	95	June 24	September 14	82
Annual Outflow						
90 <sup>th</sup> percentile	June 29	September 25	88	July 3	September 11	70
Median	June 23	September 25	94	June 24	September 15	83
10 <sup>th</sup> percentile	---	---	---	---	---	---
Pool Elevation						
90 <sup>th</sup> percentile	June 29	September 27	90	July 2	September 15	75
Median	June 21	September 21	92	June 24	September 14	82
10 <sup>th</sup> percentile	---	---	---	---	---	---
Air Temperatures						
90 <sup>th</sup> percentile	June 24	October 2	100	June 26	September 30	96
Median	June 30	September 21	83	July 2	September 11	71
10 <sup>th</sup> percentile	June 30	September 20	82	July 9	September 7	60

In the Baseline Simulation, 17°C temperatures appear on June 22 and terminate 96 days later on September 26. 18°C temperatures appear on June 24 and terminate 83 days later on September 1. As suggested in a previous discussion, annual inflow has no discernible impact on lake temperatures, and temperature differences due to annual outflow are likely caused by pool elevation differences. Higher pool elevations (90<sup>th</sup> percentile) yielded later warm water appearance dates and shorter time periods of available warm water. 17 and 18°C water appeared on June 29 and July 2, respectively; and, the number of days meeting these criteria was 90 and 75 days. With regard to air temperature, higher air temperatures (90<sup>th</sup> percentile) produced the longest number of days, 100 and 96 days, meeting the 17 and 18°C criteria, respectively. The lowest air temperatures produced the shortest number of days, 82 and 60 days, meeting the 17 and 18°C criteria, respectively, and the latest dates of appearance at June 30 and July 9.

Overall, a likely conservative scenario emulating the Baseline Simulation would allow warm water releases to begin when temperatures reach 18°C after June 24 persisting for 83 days until September 15. Actual spillway release timing would depend on the presence of warm water, spillway discharge, powerhouse discharge and temperature, and Milk River discharges and temperature.

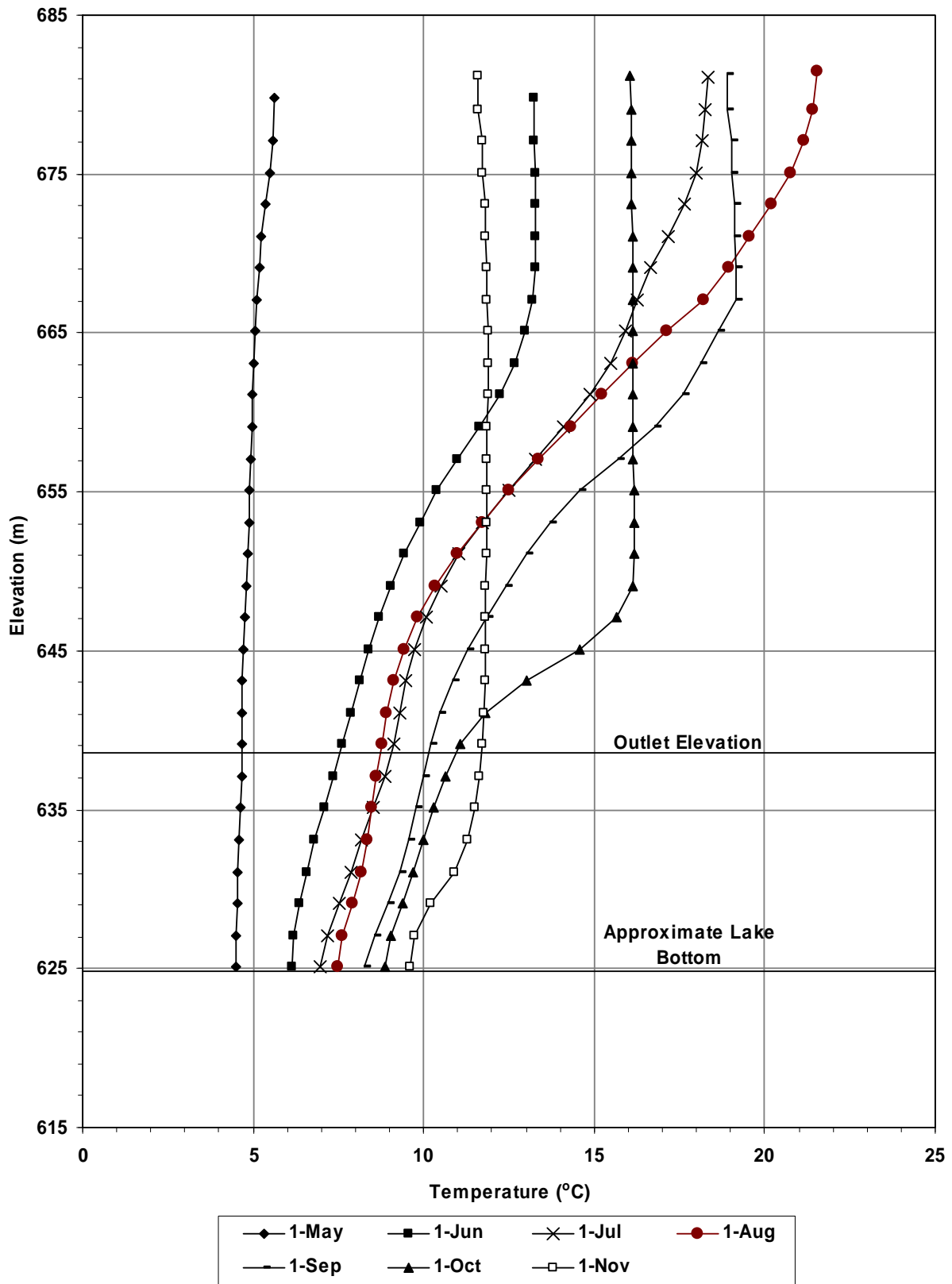


Figure 14. Baseline simulation temperature profiles at the Fort Peck Lake outlet (L1).

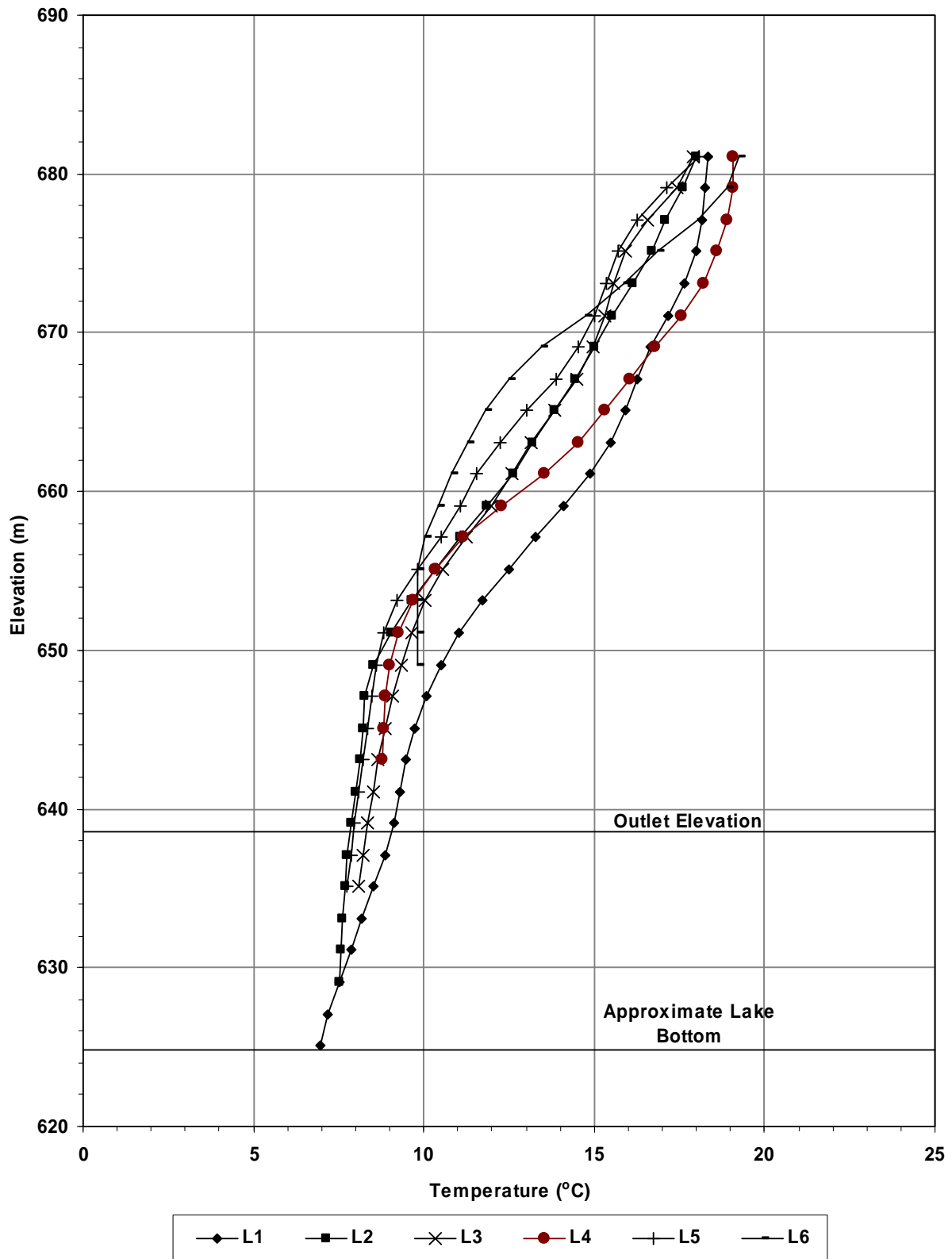


Figure 15. Baseline simulation temperature profiles on July 1.

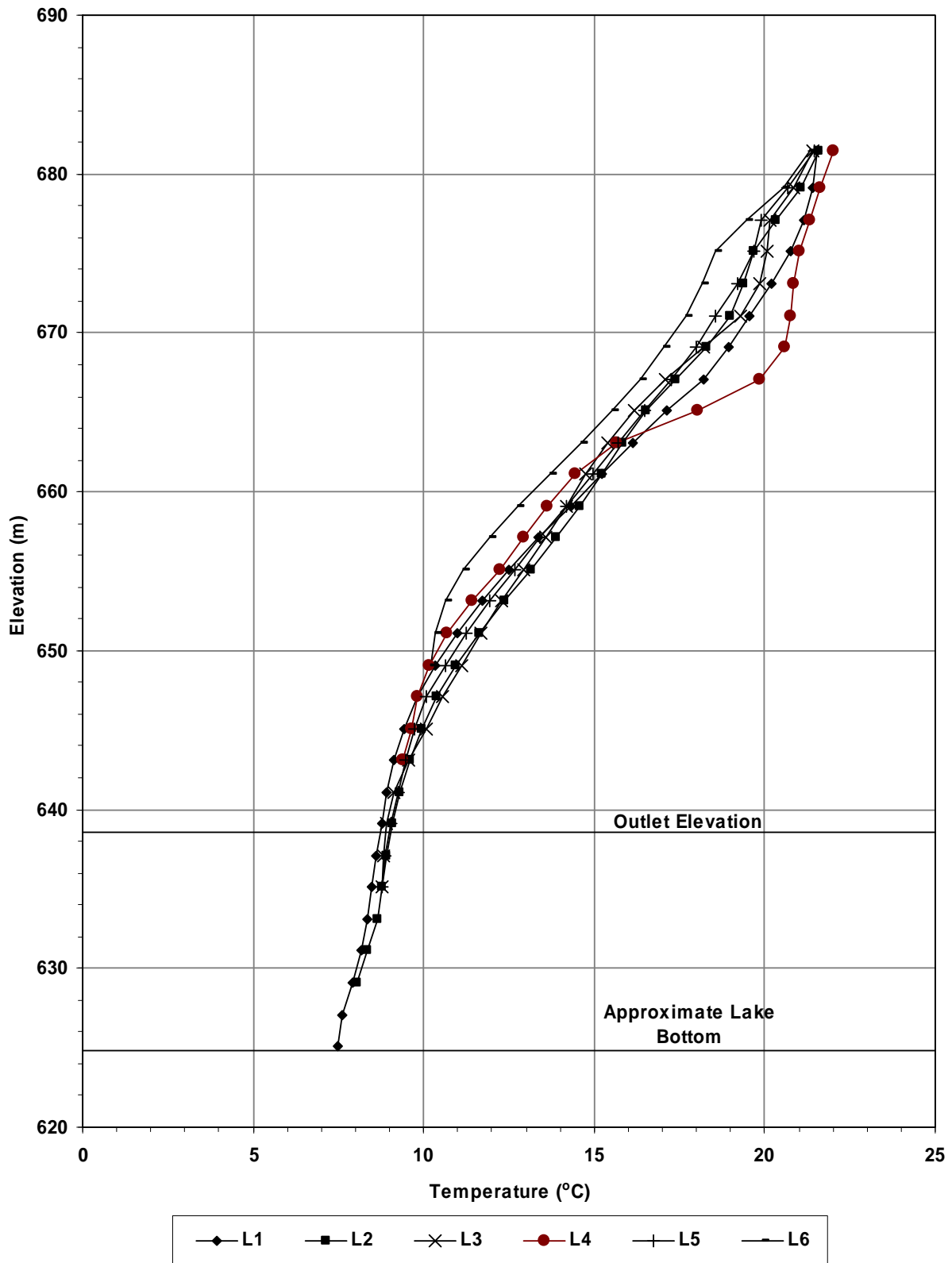


Figure 16. Baseline simulation temperature profiles on August 1.



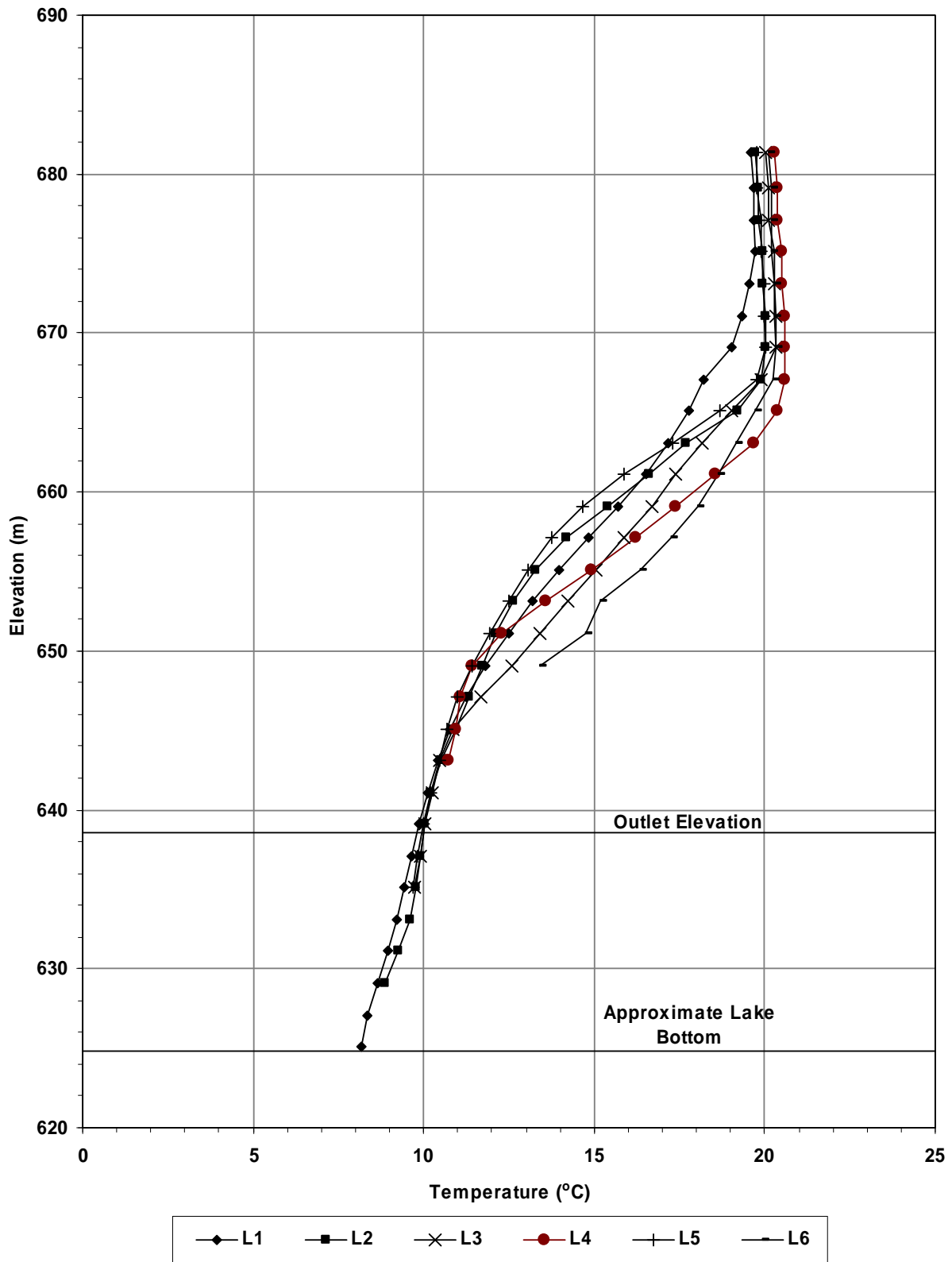
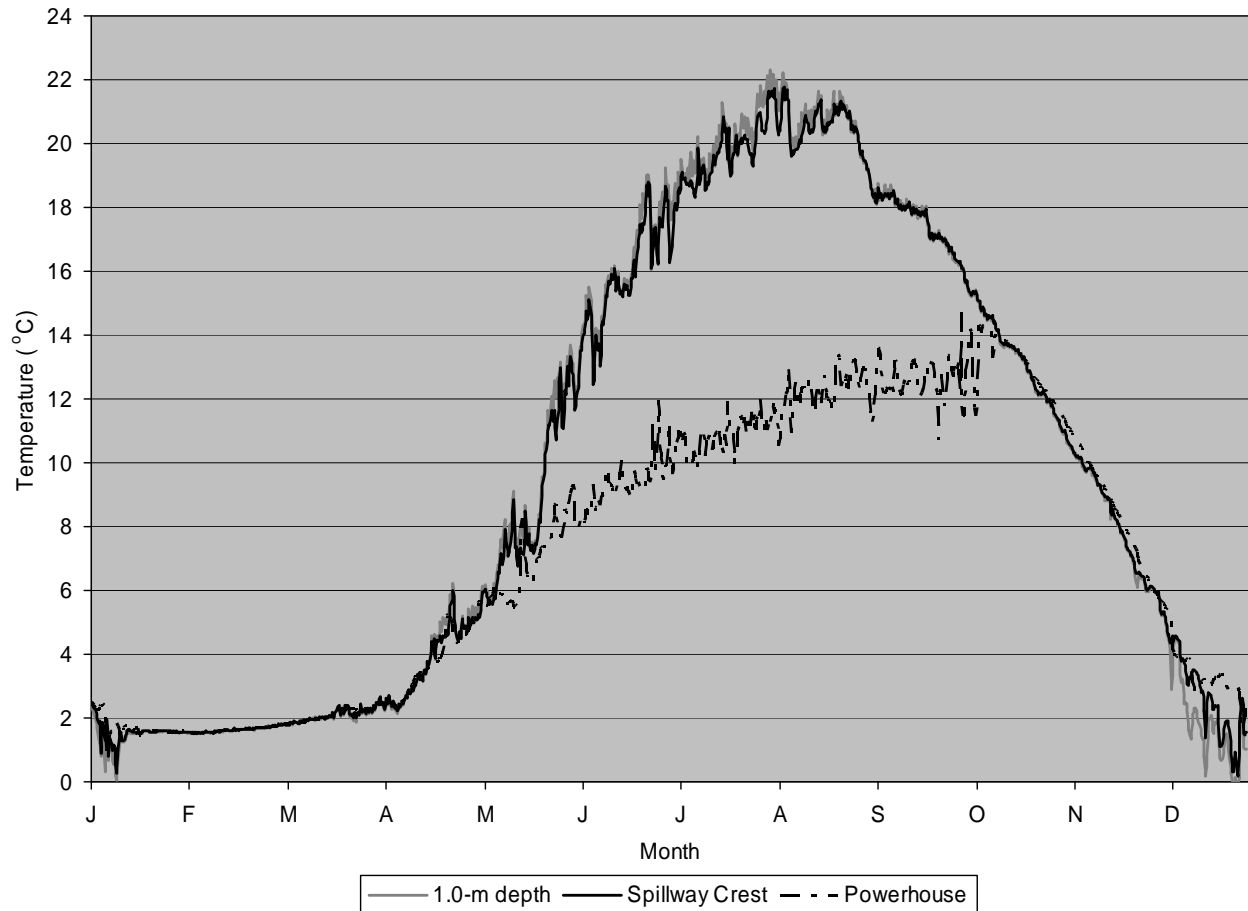
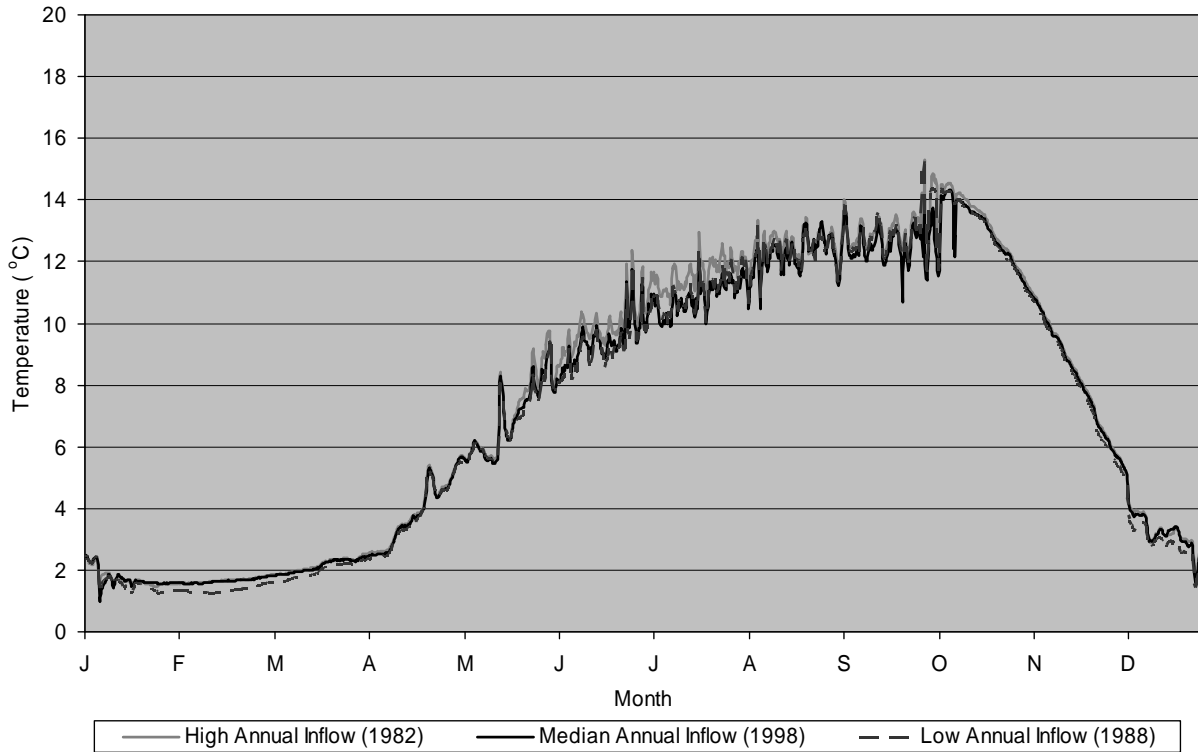


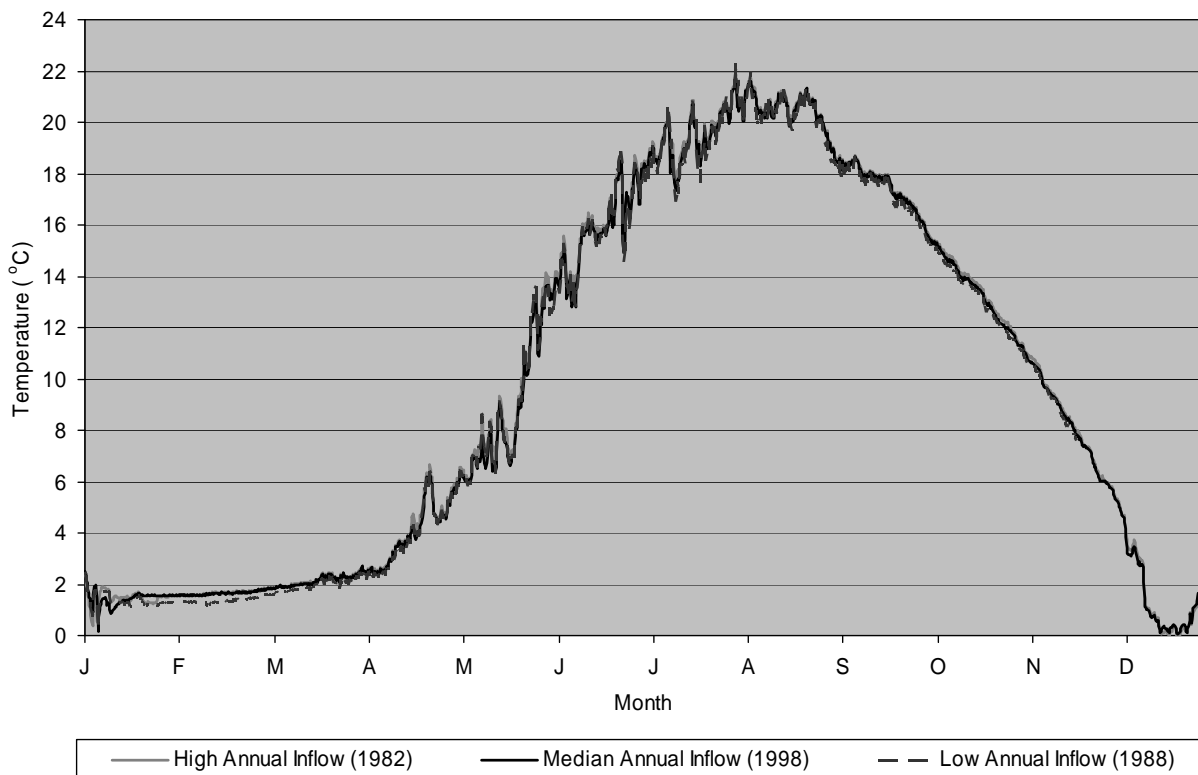
Figure 17. Baseline simulation temperature profiles on September 1.



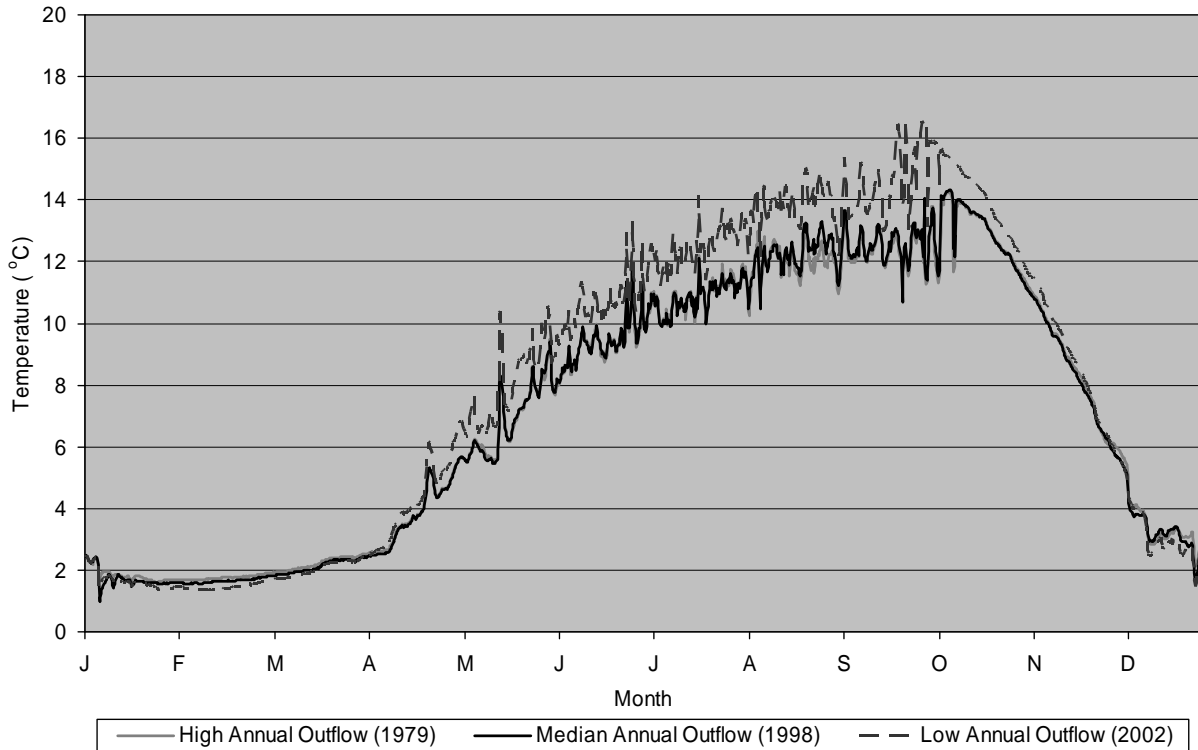
**Figure 18. Baseline Simulation temperatures near the lake surface (1.0-m depth), spillway crest elevation (678.2 m/2225 ft), and powerhouse.**



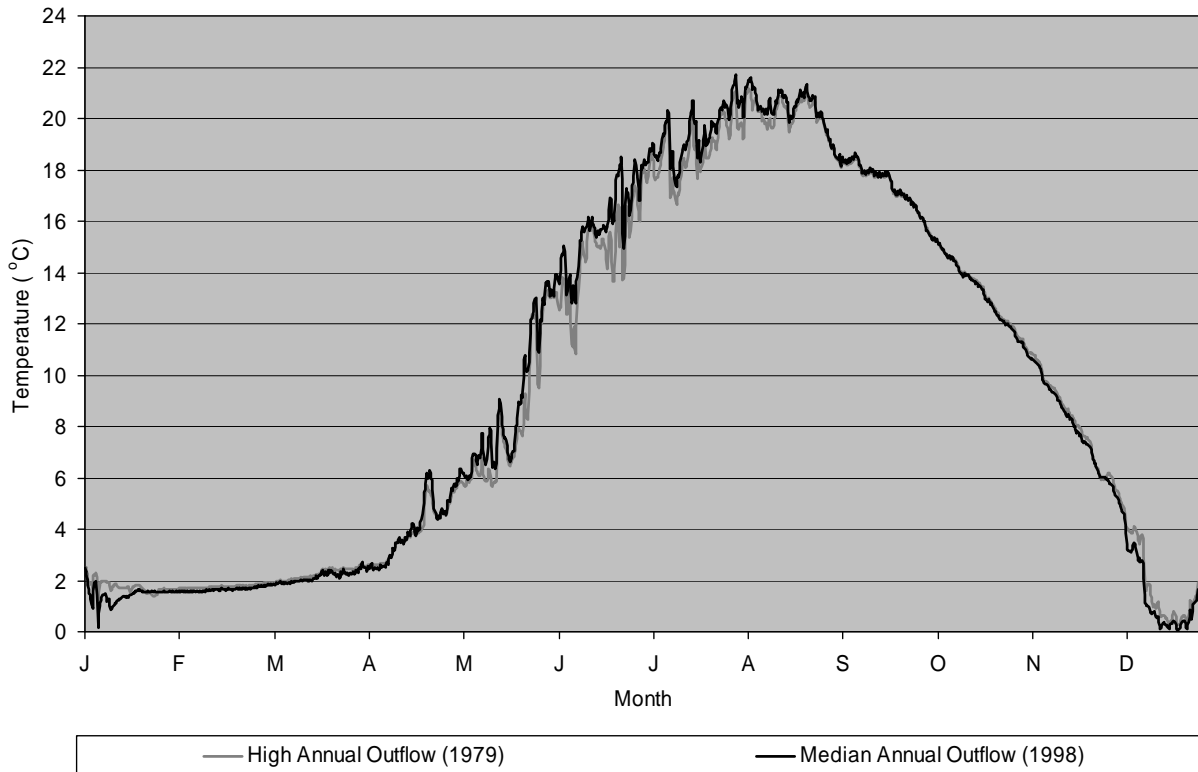
**Figure 19. Simulated Fort Peck Dam release temperatures for three annual inflow scenarios.**



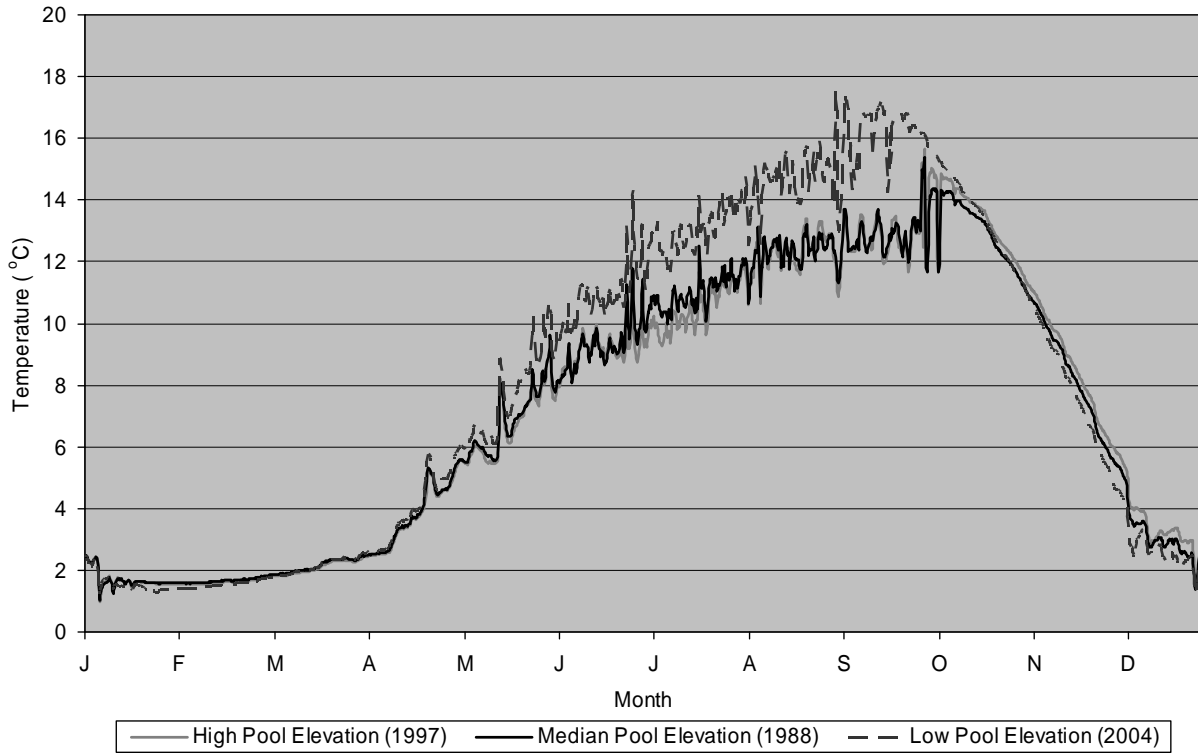
**Figure 20. Simulated Fort Peck Lake temperatures near the spillway crest elevation (678.2 m/2225 ft) for three annual inflow scenarios.**



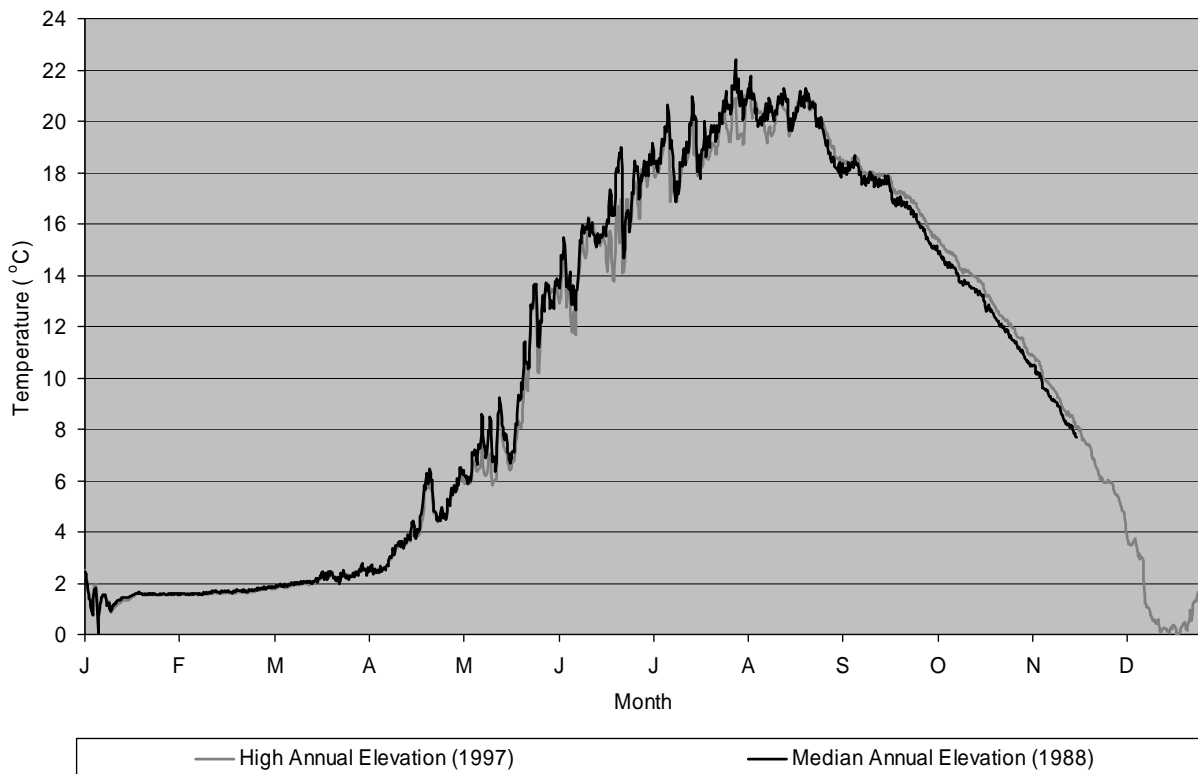
**Figure 21. Simulated Fort Peck Dam release temperatures for three annual outflow scenarios.**



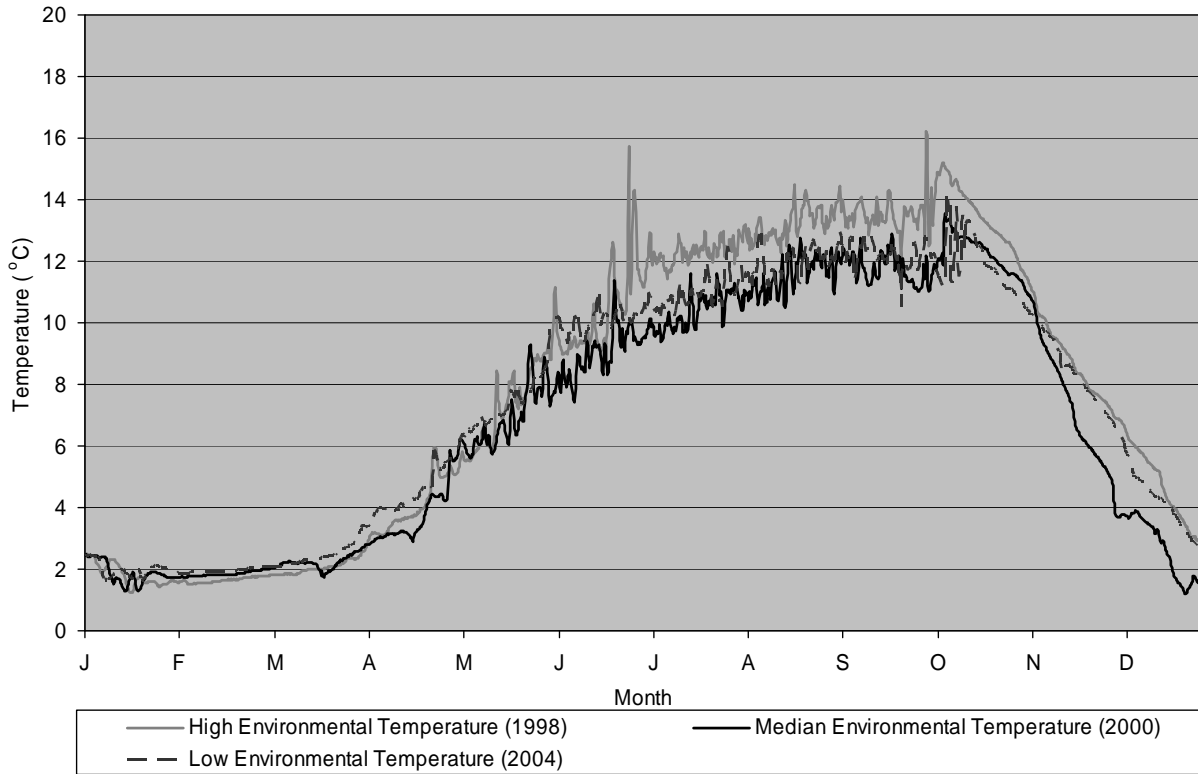
**Figure 22. Simulated Fort Peck Lake temperatures near the spillway crest elevation (678.2 m/2225 ft) for two annual outflow scenarios.**



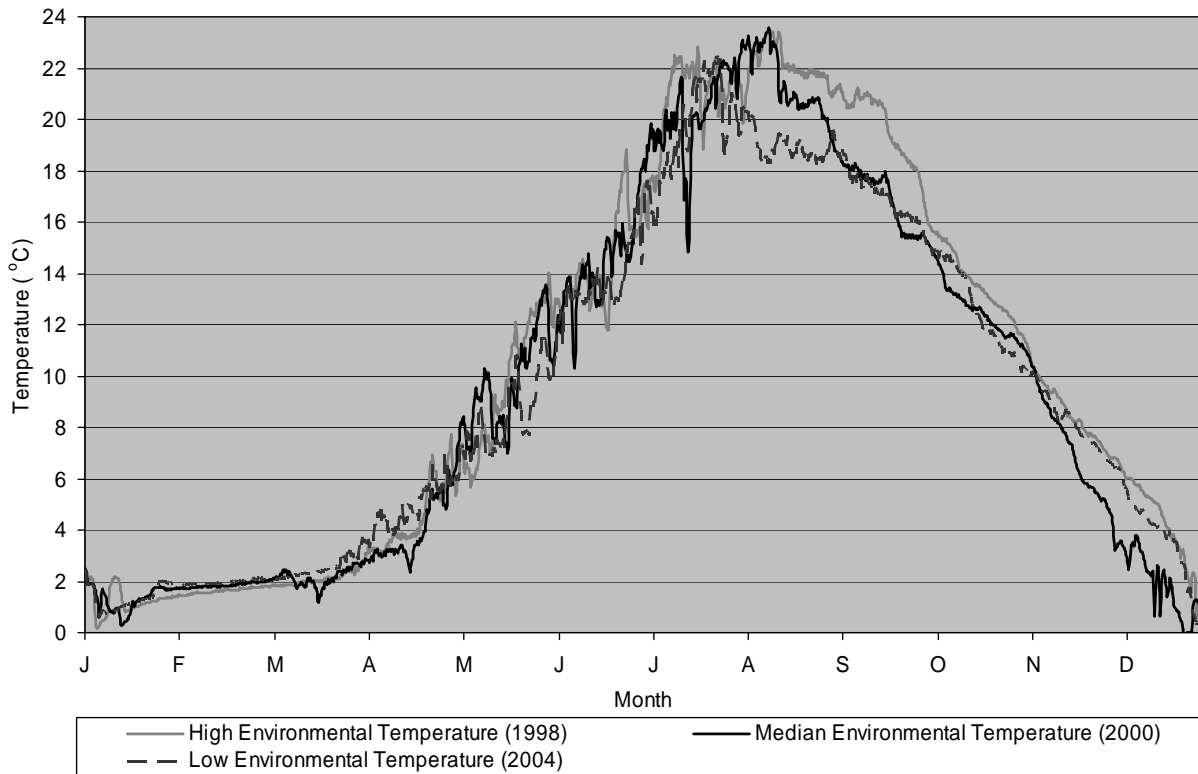
**Figure 23. Simulated Fort Peck Dam release temperatures for three pool elevation scenarios.**



**Figure 24. Simulated Fort Peck Lake temperatures near the spillway crest elevation (678.2 m/2225 ft) for two annual pool elevation scenarios.**



**Figure 25. Simulated Fort Peck Dam release temperatures for three environmental temperature scenarios.**



**Figure 26. Simulated Fort Peck Lake temperatures near the spillway crest elevation (678.2 m/2225 ft) for three environmental temperature scenarios.**

### 3.4 River Temperature Analysis

River scenarios were based on Fort Peck Dam discharge and temperature conditions, and environmental air temperatures during the simulation year. Simulations in each category used measured Fort Peck Dam discharge, simulated discharge temperatures from the calibrated lake model, and measured discharge at the Milk River and the Missouri River at Culbertson, MT. Discharge temperatures at the Milk River and Culbertson, MT were available through USGS measurements performed from May 17 to October 9, 2001 to 2006, but in other years data was sparse.

The datasets chosen for the simulations is summarized in Table 8. Calendar year 1994 worked well as the median temperature meteorological year, though year 2000 was used as the median case in the Air Temperature category. In addition, a baseline simulation using 1998 simulated lake conditions with 1994 meteorology was performed to represent normal river conditions.

**Table 8. Missouri River downstream of Fort Peck - simulations and datasets used in the existing management analysis.**

Analysis Parameter	Variation	Inflow/Outflow/ Elevation Year	Meteorological Year
Baseline Simulation		1998	1994
Annual Discharge	90 <sup>th</sup> percentile	1979	
	Median	1998	1994
	10 <sup>th</sup> percentile	2002	
Pool Elevation	90 <sup>th</sup> percentile	1997	
	Median	1988	1994
	10 <sup>th</sup> percentile	2004	
Air Temperature Set	90 <sup>th</sup> percentile		1998
	Median	1998	2000
	10 <sup>th</sup> percentile		2004

#### 3.4.1 Typical River Simulation

The Baseline Simulation was performed using 1998 hydrodynamic data (Figure 27) and 1994 meteorological data. Both 1998 Milk River and Fort Peck Dam discharges were used in the simulation. During the 1998 calendar year, the Fort Peck pool elevation averaged 681.9 m (2237.1 ft), and the average annual outflow was 252 cms (8,900 cfs). Since the pool elevation was below the 3<sup>rd</sup> quartile level and annual outflow was near the median value, it was believed the 1998 hydrodynamics were representative of a typical operational year. Milk River discharges in 1998 were generally low (Figure 27). It did not exhibit spring plains snowmelt runoff, but only one major runoff event in early July.

Missouri River discharge temperatures (Figure 28) used simulated Fort Peck Dam release temperatures from the Baseline Simulation at the upstream river model boundary. Milk River temperatures were assembled from May to October 1988 observed data, and other measured data for the remainder of the year. Since Fort Peck Dam releases generally dominate downstream discharges, the Milk River discharge influenced the Milk-Missouri flow-weighted discharge temperatures only during the July runoff event.

Flow-weighted Missouri River inflow temperatures do not exceed 15°C during the simulation year. At Frazer Rapids, temperatures increase several degrees throughout the summer

months, but they do not exceed the 18°C temperature criteria (Figure 29). At Wolf Point temperatures reach the criteria in several instances, while at Culbertson, MT, river temperatures exceed the criteria from mid-June to late August, sometimes exceeding 20°C. April to September temperatures increased 1.8, 3.5, and 5.5°C, from Fort Peck Dam to Frazer Rapids, Wolf Point, and Culbertson, respectively (Figure 30). May to August average temperature increases were 2.2, 4.3, and 6.9°C.

### 3.4.2 Annual Discharge

Low annual discharge through the Missouri River model produced higher river temperatures at Frazer Rapids than the median and high annual discharge scenarios due to higher release temperatures from Fort Peck Dam (Figure 31). Release temperatures were greater in the low annual discharge scenario due to a lower pool elevation in the lake simulation used to generate the low discharge outflow temperatures. Temperatures reached the 18°C criteria only two times during the simulation period. The lowest river temperatures occurred in the high discharge simulation.

### 3.4.3 Pool Elevation

Elevation scenarios in the lake generated the greatest separation in temperature of all Missouri River downstream of Fort Peck simulations. The low annual Fort Peck lake elevation scenario resulted in the highest river temperatures at Frazer Rapids (Figure 32). The high annual elevation scenario resulted in the lowest river temperatures at Frazer Rapids except during fall lake turnover in October.

Low annual pool elevations yield the warmest discharge temperatures from the powerhouse; however, elevations that result in a substantial temperature gain would be lower than the spillway release cutoff elevation of 679.7 m (2230 ft). Alternative means of release must be implemented in order to utilize the release temperature advantage.

### 3.4.4 Environmental Temperature

The environmental temperature impacts on river temperatures were evaluated in two sets of simulations: 1) identical Missouri River input temperatures for the three environmental temperature scenarios, and 2) Fort Peck dam release temperatures generated from the three environmental temperature lake simulations. Set 1 river inflow temperatures are identical in all three simulations using 1998 flow data and 2000 meteorological data, allowing the impact of environmental temperature on river temperature to be evaluated without bias of input temperature. Set 2 river inflow temperatures use the 90<sup>th</sup> percentile, median, and 10<sup>th</sup> percentile Fort Peck dam outflow temperatures generated in the reservoir simulations to evaluate the difference in Frazer Rapids temperatures under varied dam release temperatures.

In simulation Set 1, the high environmental temperature scenario generated slightly higher river temperatures than the median and low environmental temperature scenarios at Frazer Rapids (Figure 33). In general, environmental temperatures alone had very limited influence on river temperatures at Frazer Rapids, but more pronounced influence at downstream locations.

In simulation Set 2, the high environmental temperatures and high temperature releases resulted in noticeably higher river temperatures at Frazer Rapids (Figure 34) while median and low environmental temperature scenarios were essentially the same until lake turnover. The high temperature scenario offered a 1.2°C temperature advantage above the median temperature



scenario at Frazer Rapids. When the reservoir and river work as a system and are subjected to varying temperature conditions in both the lake and river, the difference in river temperature is appreciable, especially when environmental temperatures are high.

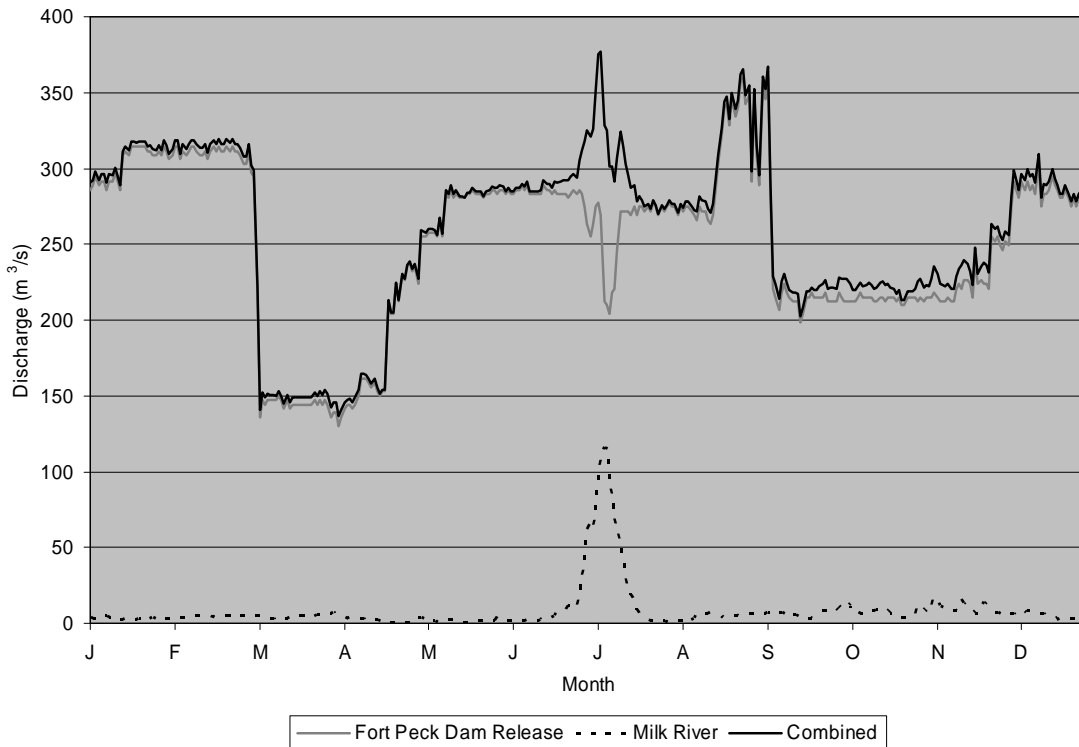
### 3.5 Summary of River Analysis

During Baseline Simulation (1998 discharges and 1994 meteorology), average river temperatures at Frazer Rapids, MT, from April to September were 10.9°C, while June to August temperatures were 13.2°C (Table 9). The peak daily temperature reached 17.3°C, while the peak 30- and 60-day average temperatures were 14.3 and 14.1°C, respectively. Fort Peck Dam discharges and pool elevation had some influence on river temperatures at Frazer Rapids, MT. Lower annual river inflow (10<sup>th</sup> percentile) produced higher temperatures than high river inflow (90<sup>th</sup> percentile), while low pool elevations (10<sup>th</sup> percentile) produced a similar result. The peak daily temperatures reached in the 10<sup>th</sup> percentile Annual Inflow and Pool Elevation simulations were 18.8 and 18.7°C, respectively. Peak 30-day average temperatures were only 15.6 and 16.4°C for the same respective simulations.

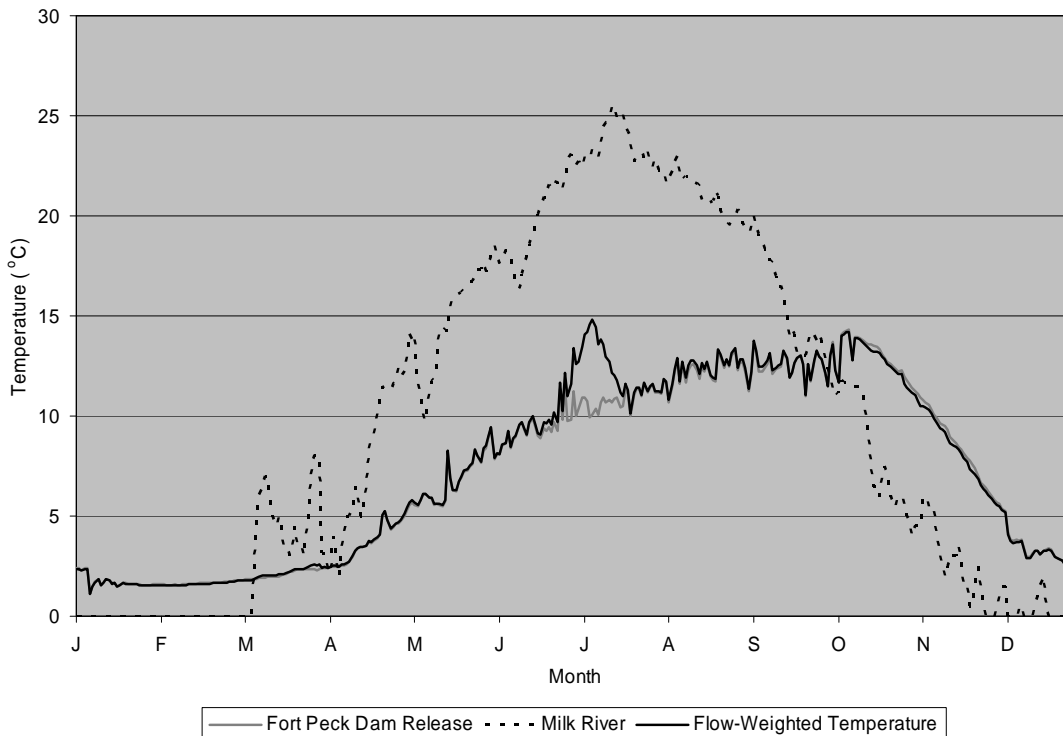
Air Temperature simulations produced the expected result: higher environmental air temperatures produce higher river temperatures at Frazer Rapids. Air Temperature Set 2 represents the more realistic scenario of river temperatures being influenced by warm environmental temperatures and varied inflow temperatures. Median and 10<sup>th</sup> percentile simulated river temperatures are similar, yet the 90<sup>th</sup> percentile scenario (high environmental temperature) produced a 19.1°C peak temperature, a 16.0°C 30-day average, and 14.1°C 60-day average.

**Table 9. Summary of average and peak river temperatures on the Missouri River at Frazer Rapids, MT.**

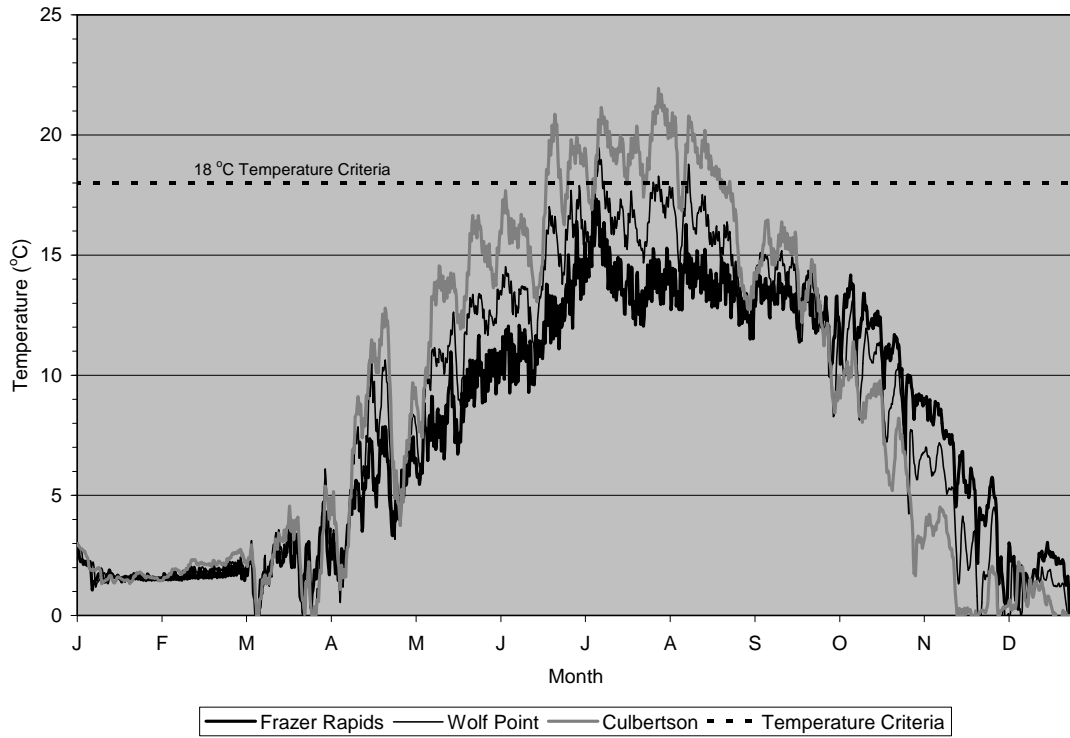
	-- Average Temperature (°C) --		----- Peak Temperature (°C) -----		
	April - September	June - August	Daily	30-Day Average	60-Day Average
Baseline Simulation	10.9	13.2	17.3	14.3	14.1
Annual Inflow					
90 <sup>th</sup> percentile	10.7	12.6	15.8	13.7	13.4
Median	10.9	13.2	17.3	14.3	14.1
10 <sup>th</sup> percentile	11.9	14.4	18.8	15.6	15.2
Pool Elevation					
90 <sup>th</sup> percentile	10.9	12.7	15.7	13.4	13.4
Median	11.1	13.3	16.8	14.5	14.0
10 <sup>th</sup> percentile	12.4	15.0	18.7	16.4	16.0
Air Temperature Set 1					
90 <sup>th</sup> percentile	10.9	13.0	18.2	14.6	14.1
Median	10.6	13.0	17.1	14.5	14.0
10 <sup>th</sup> percentile	10.5	12.6	17.4	14.2	13.6
Air Temperature Set 2					
90 <sup>th</sup> percentile	11.8	14.2	19.1	16.0	15.5
Median	10.6	13.0	17.1	14.5	14.0
10 <sup>th</sup> percentile	10.9	13.1	17.7	14.7	14.0



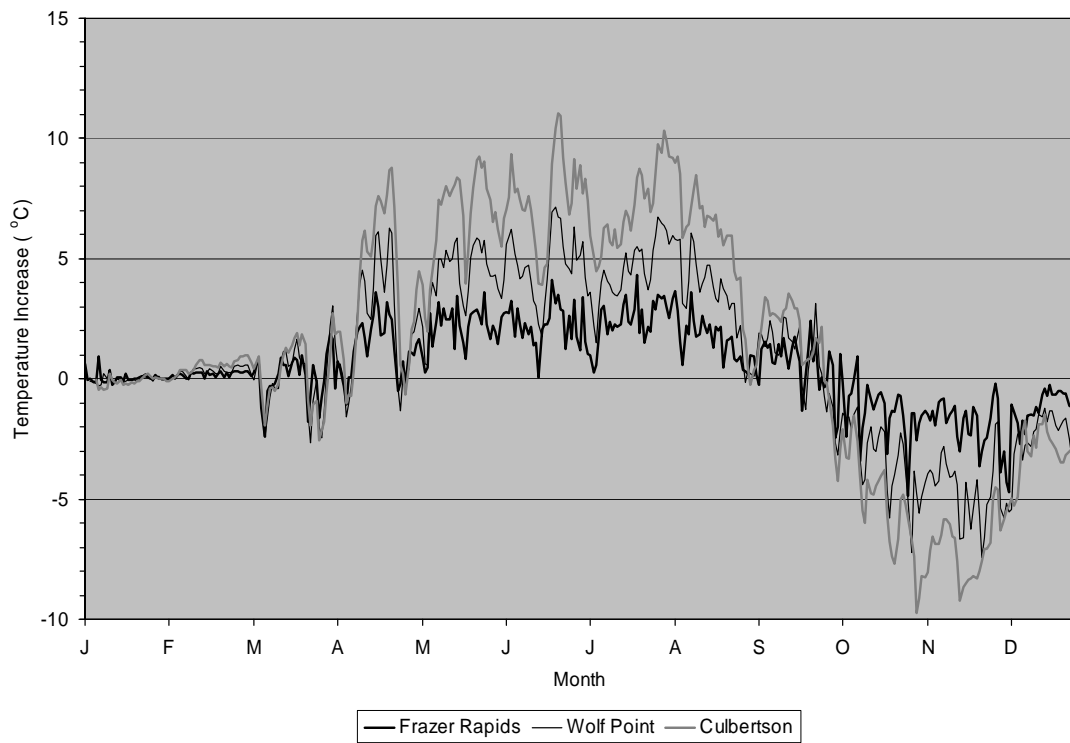
**Figure 27. Missouri R. Baseline Simulation: Fort Peck Dam, Milk River, and combined discharge (cfs).**



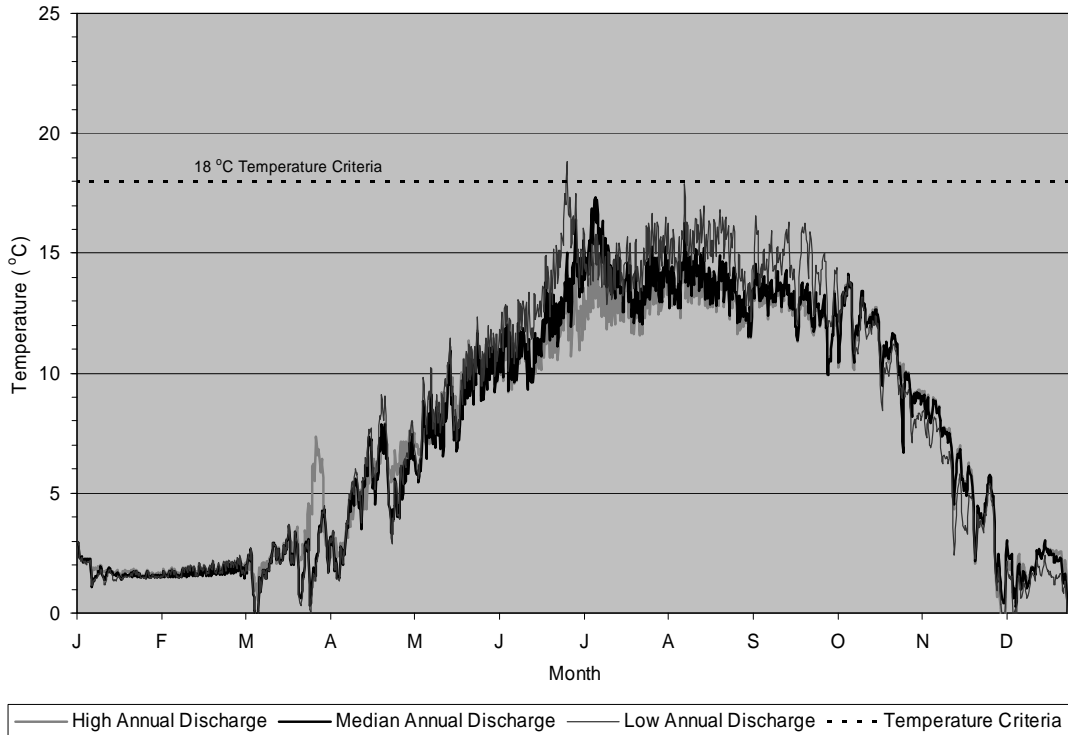
**Figure 28. Missouri R. Baseline Simulation: Fort Peck Dam, Milk River, and flow-weighted temperatures.**



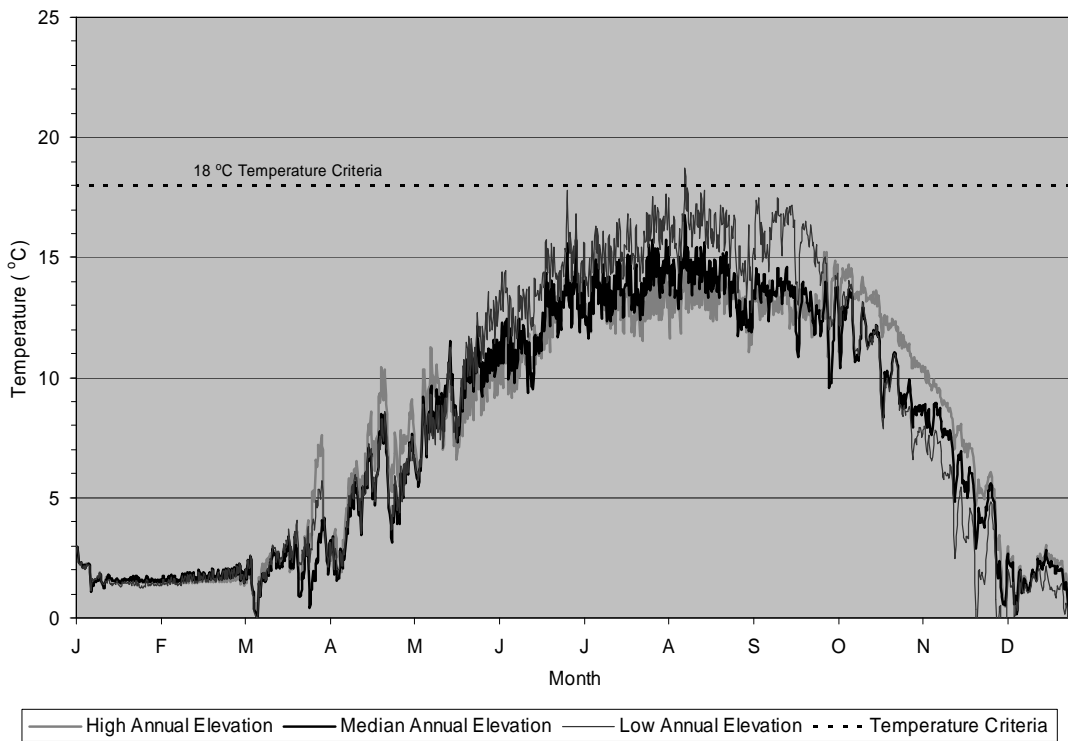
**Figure 29. Missouri R. Baseline Simulation: river temperature at Frazer Rapids, Wolf Point, and Culbertson, MT.**



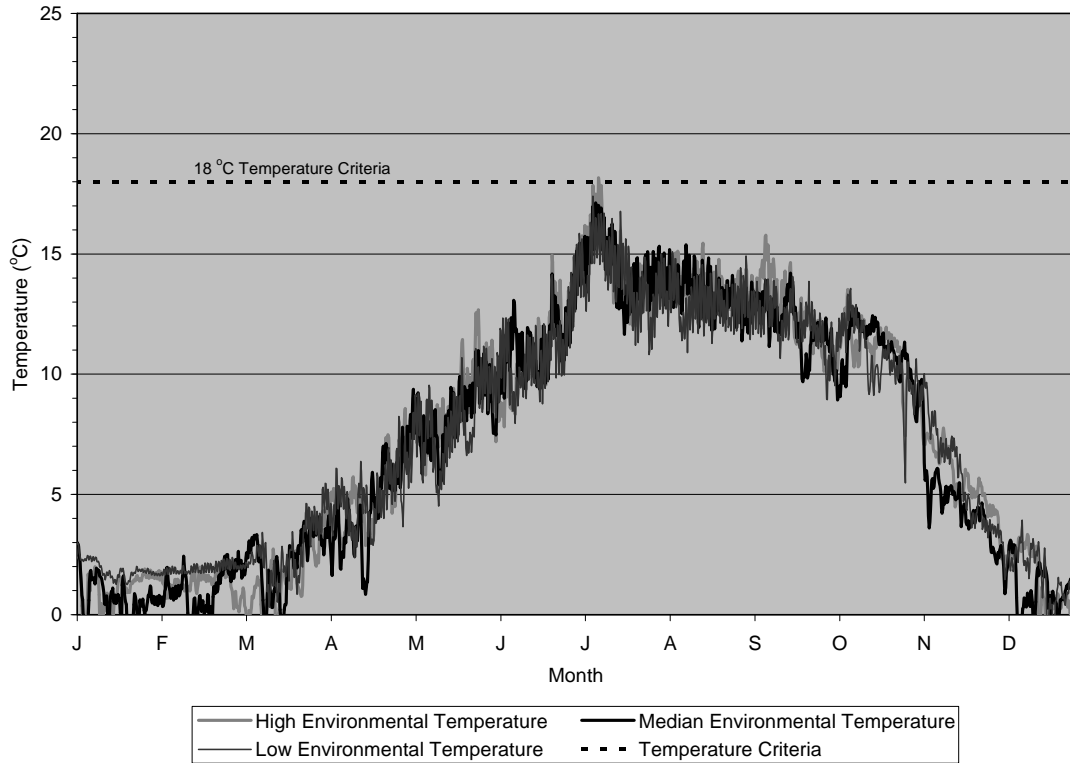
**Figure 30. Missouri R. Baseline Simulation: discharge temperature increases from Fort Peck Dam.**



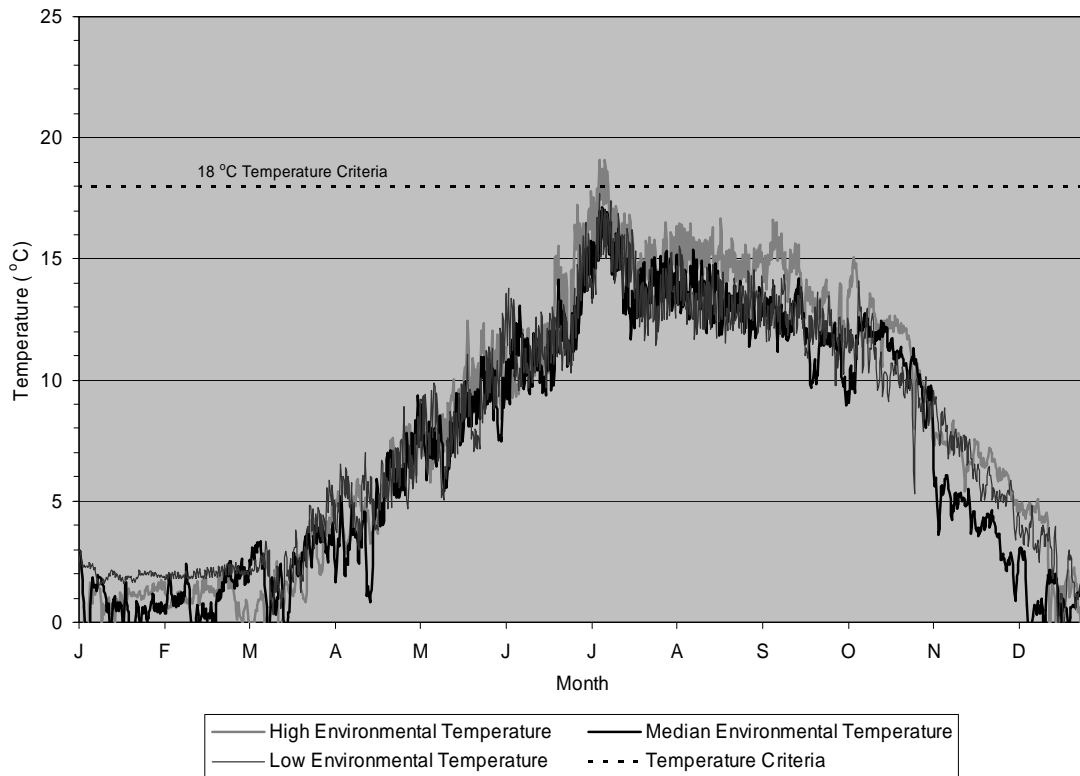
**Figure 31. Annual Discharge Scenario Simulations: Missouri River temperatures at Frazer Rapids, MT.**



**Figure 32. Annual Elevation Scenario Simulations: Missouri River temperatures at Frazer Rapids, MT.**



**Figure 33. Environmental Temperature Scenario Simulations Set 1 (identical inflow temperatures): Missouri River temperatures at Frazer Rapids, MT.**



**Figure 34. Environmental Temperature Scenario Simulations Set 2 (varied inflow temperatures): Missouri River temperatures at Frazer Rapids, MT.**

## 4 TEMPERATURE ANALYSIS UNDER ALTERNATIVE RELEASES

### 4.1 Spillway Releases

#### 4.1.1 Spillway Full Test

The Spillway Full Test was originally planned to be conducted during the spring of 2002 following the Mini Test. The purpose of the Mini Test was to gain sufficient data on combinations of spillway and powerhouse releases and temperatures to develop discharge temperature relationships for downstream temperature targets; however, a full test can be conducted using the Fort Peck Lake/Missouri River water temperature model. The Full Test will determine what combinations of spillway and powerhouse releases will achieve the 18°C temperature target at Frazer Rapids under the following guidance outlined in the Missouri River Biological Opinion (2000).

- a. Releases from the spillway will commence two to three days or up to seven days after the beginning of the rising stage on the Missouri River at the Landusky, MT gauge, but not before May 15.
- b. The peak combined discharge will range from 566 to 707.9 cms (20,000 to 25,000 cfs) with a minimum powerhouse release of 113.3 cms (4,000 cfs) for a minimum of three days. Discharges will gradually be reduced after meeting the peak discharge target and time. The combined discharge is the sum of powerhouse and spillway releases and the Milk River discharge.
- c. The combined releases should achieve a minimum temperature of 18°C (64.4°F) at Frazer Rapids for a minimum of 30 days.
- d. Spillway releases should be made for up to 60 days from the day that the spillway gates are opened in order to achieve the temperature target.

The Full Test simulations were performed using 1998 lake and river hydrodynamic data and 1994 meteorological data to emulate median hydrodynamic and meteorological conditions. During the 1998 calendar year, the Fort Peck pool elevation averaged 681.9 m (2237.1 ft), which is below the 3<sup>rd</sup> quartile elevation of 682.4 m (2238.8 ft), and the average annual outflow was 252 cms (8,900 cfs) near the median value. Fort Peck Lake release temperatures were determined from 1998 lake hydrodynamics and 1994 meteorological data. Since the spring river rise at Landusky, MT, began on approximately June 20, spillway releases were initiated on June 22. Combined spillway and powerhouse discharges were ramped up in order to meet a 707.9-cms (25,000-cfs) flow target below the mouth of the Milk River over a three-day period while reducing powerhouse releases to 113.3 cms (4,000 cfs). The peak discharge was held for three days, and then the combined flows were sustained with an assumed 1°C powerhouse discharge temperature gain and a 0.5°C spillway and Milk River discharge gain.

The three variations of the Full Test are described in Table 10. In FT 1, 18°C discharges were targeted at Frazer Rapids for a duration of 30 days, after which spillway discharges were ceased and powerhouse discharges were returned to normal. The FT 2 scenario was the same as FT 1; however, after meeting the 18°C temperature target for 30 days, powerhouse discharges were returned to normal and spillway discharges were continued through the end of the 60-day period spillway release period. In FT 3 at the end of the 30-day period temperature period,

powerhouse and spillway discharges were increased by 57 cms (2,000 cfs) and maintained for the remainder of the 60-day period release period in order to maintain an 18°C target temperature at Frazer Rapids.

**Table 10. Spillway Full Test and Alternative simulation scenarios.**

Simulation	Target Release Date	Fort Peck Spillway		Release Duration days	Fort Peck Powerhouse		18°C Target Duration days
		Target Discharge, m <sup>3</sup> /s (ft <sup>3</sup> /s)			Discharge m <sup>3</sup> /s (ft <sup>3</sup> /s)	Duration days	
		Peak	Sustained				
FT 1	6/22	586 (20700)	283 (10000)	43	113 (4000)	39	30
FT 2	6/22	586 (20700)	283 (10000)	60	113 (4000)	39	30
FT 3	6/22	586 (20700)	283 (10000)	60	113 (4000)/ 170 (6000)	40/ 20	30
SW 1	6/25	340 (12000)	340 (12000)	60	136 (4800)	60	30
SW 2	6/25	340 (12000)	227 (8000)	60	85 (3000)	60	30
SW 3	6/25	396 (14000)	396 (14000)	60	normal	60	30

#### 4.1.2 Alternative Spillway Releases

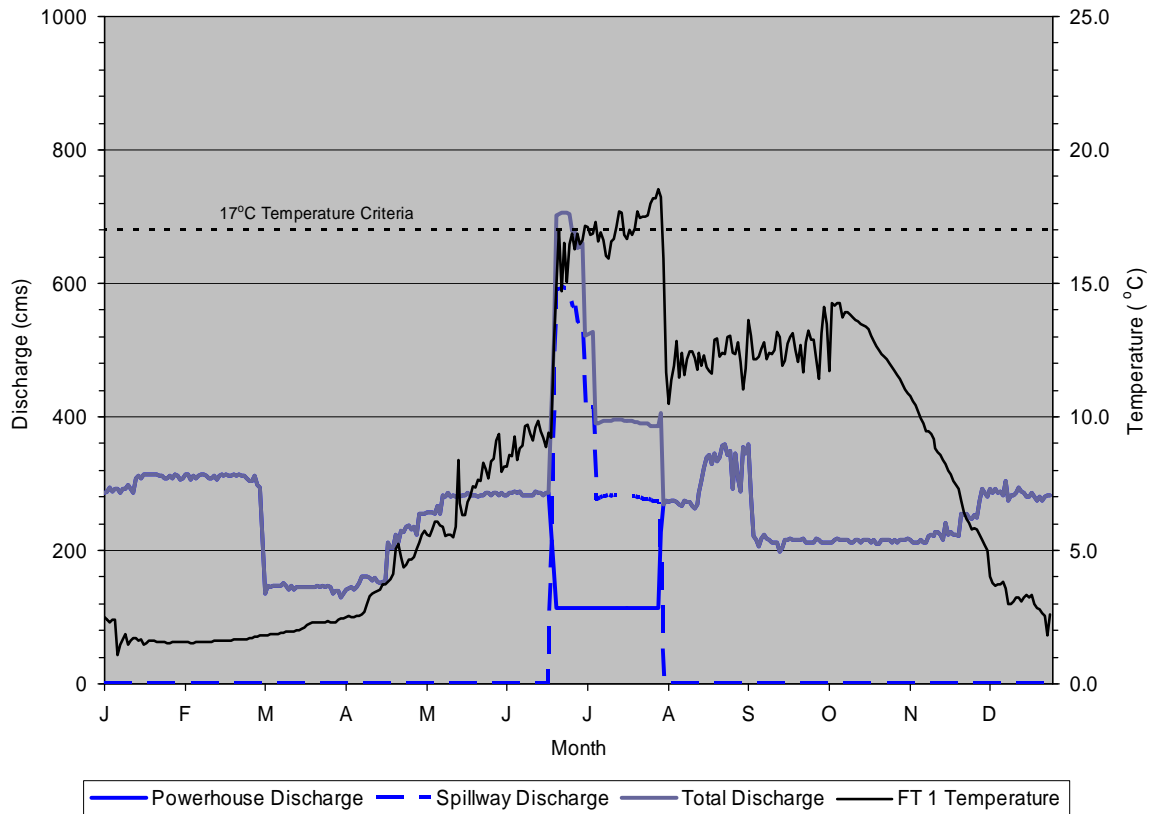
Alternative spillway release scenarios were evaluated with the river model to determine the timing and volume of water needed to be released from the Fort Peck spillway in order to meet the 18°C temperature target at Frazer Rapids, MT. Alternative spillway releases described in Table 10 were similar to Full Test simulations; however, they utilized a 340 cms (12,000 cfs) initial spillway discharge, and they incorporated three different powerhouse discharges. Subsequent discharges were made at a level achieving the 18°C temperature for the remainder of the 60-day discharge period.

#### 4.1.3 Spillway Release Results

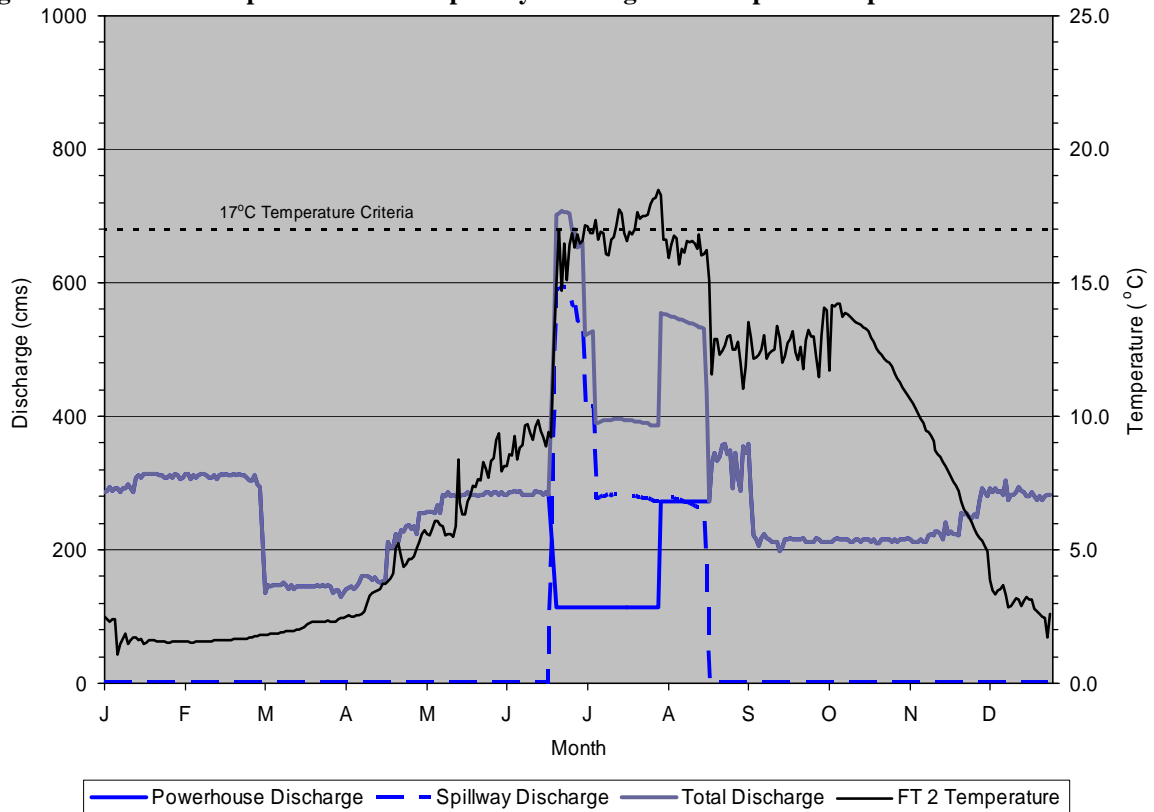
River temperatures below the dam, computed from Full Test powerhouse and spillway outflows, and Full Test dam releases are shown in Figures 35 - 37. Beginning on June 21, discharges were increased to a minimum of 540 cms (19,070 cfs) for 11 days, and then reduced to levels needed to maintain the 18°C temperature at Frazer Rapids, MT. FT 1 (Figure 35) spillway releases were maintained until August 2, while FT 2 and FT 3 (Figures 36 and 37) spillway releases were maintained until August 21. In each full test simulation temperature increases at Frazer Rapids coincided with Fort Peck spillway releases.

At the end of the 30-day 18°C spillway release period, FT 1 temperatures decrease about 5°C to about 14°C (Figure 35). FT 2 temperatures drop about 2°C at the end of the 30-day period, and no longer maintain 18°C at Frazer Rapids as powerhouse releases are returned to normal (Figure 36). In the FT 3 simulation, powerhouse releases were increased 57 cms (2000 cfs) and spillway releases were increased to maintain 18°C temperatures at Frazer Rapids through the 60-day period (Figure 37).

During the Full Test simulations Frazer Rapids temperatures achieve 18°C with some consistency after July 4 with diurnal fluctuations in which temperatures reach daily maximums at late afternoon hours (Figure 38). Temperatures are also influenced by cooler weather periods and warmer weather periods most notable in early August. FT 3 maintains 18°C temperatures best for the 60 day period. At the end of all Full Test simulations river temperatures return to normal dam operations temperatures (13 – 15°C).

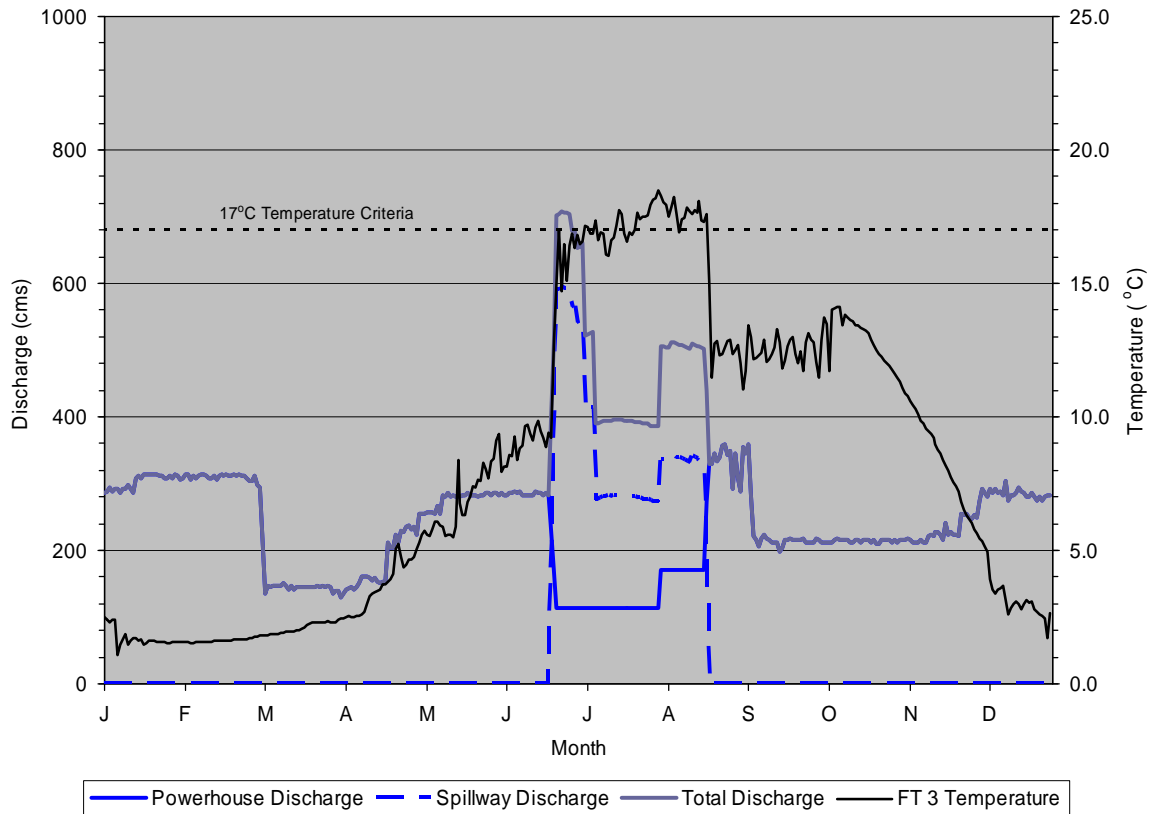


**Figure 35. Full Test 1: powerhouse and spillway discharge and computed temperature bl Fort Peck Dam.**

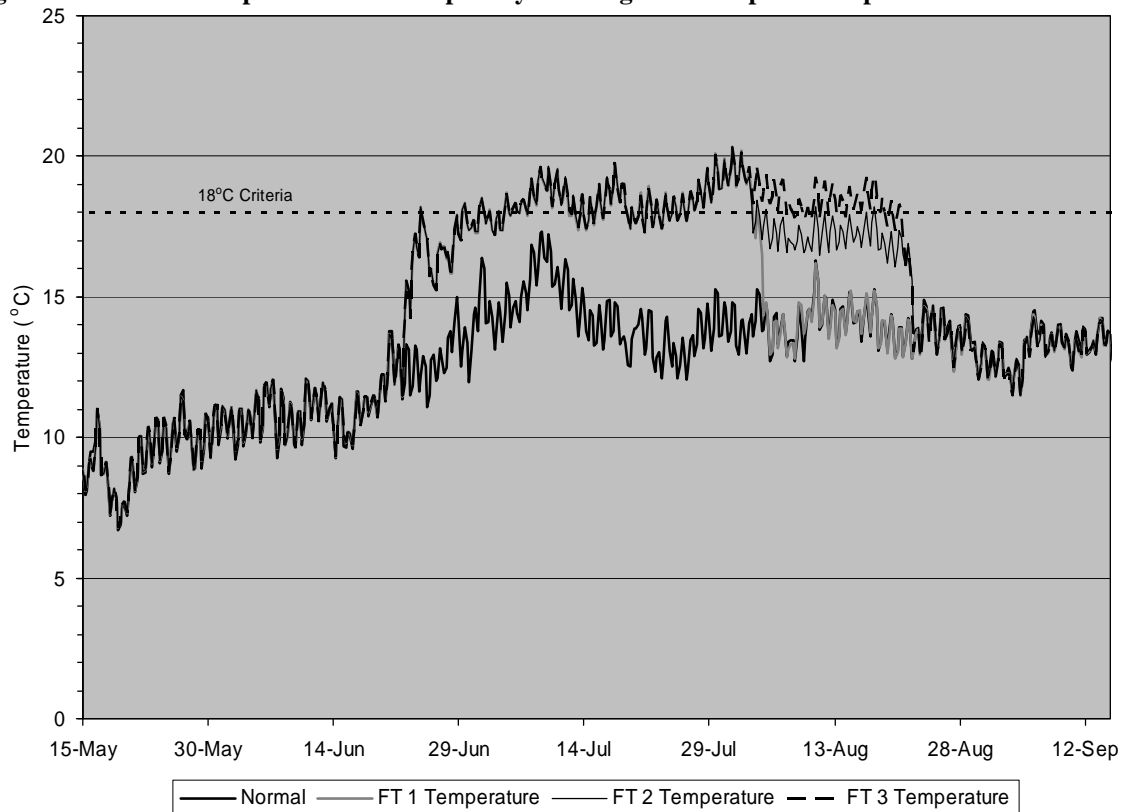


**Figure 36. Full Test 2: powerhouse and spillway discharge and computed temperature bl Fort Peck Dam.**





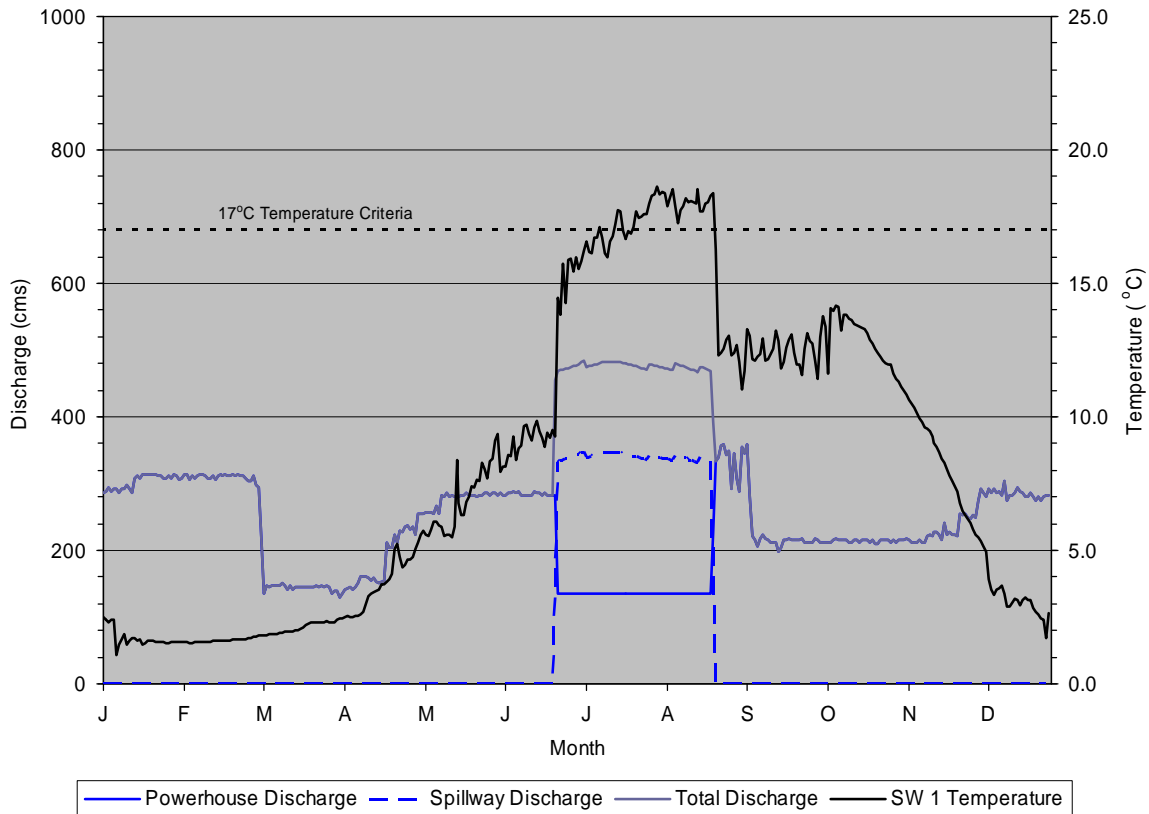
**Figure 37. Full Test 3: powerhouse and spillway discharge and computed temperature at Fort Peck Dam.**



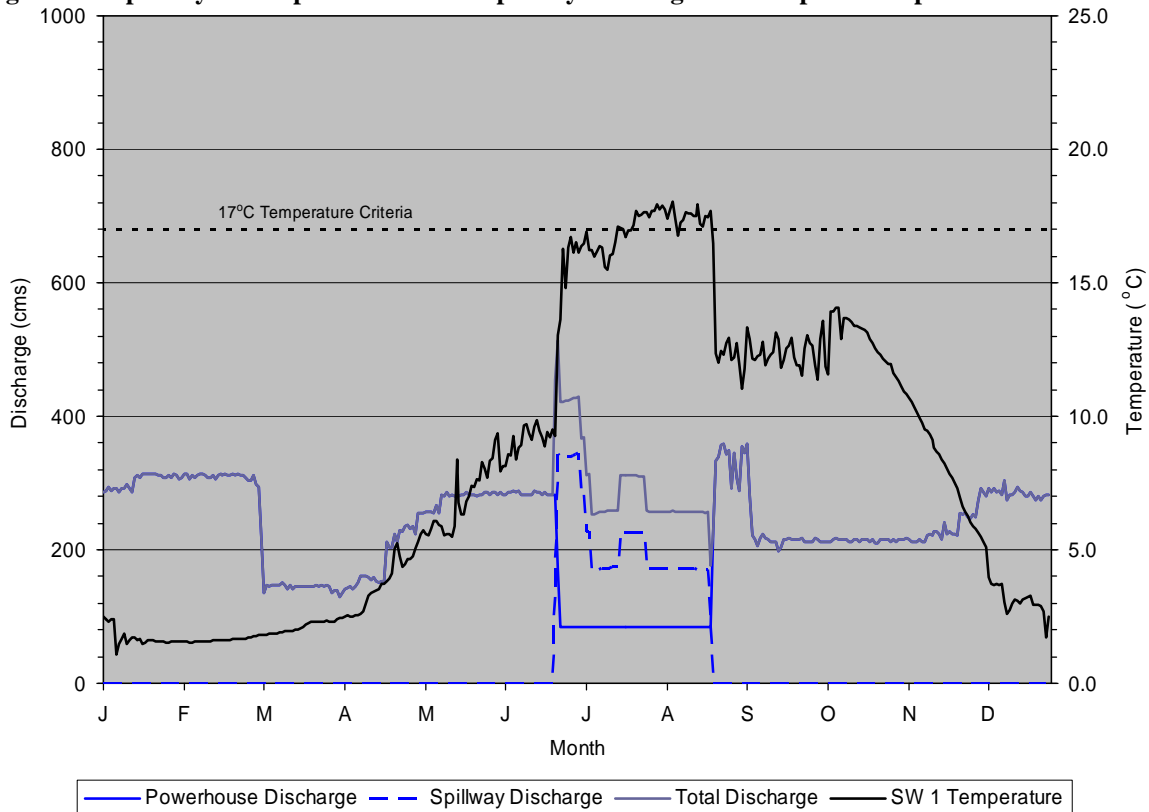
**Figure 38. Comparison of Full Test simulated river temperatures at Frazer Rapids, MT.**

Spillway Alternative simulated river temperatures at Frazer Rapids, MT, along with spillway and powerhouse discharges are shown in Figures 39 - 41. Beginning on June 23, spillway releases were made for a period of 60 days, while powerhouse releases were decreased in SW 1 and SW 2, but maintained at normal releases in SW 3. In each simulation, river temperature increases at Frazer Rapids coincided with Fort Peck spillway releases. The drop in powerhouse discharge in SW 1 (Figure 39) and SW 2 (Figure 40) allowed lower spillway discharges to be made while achieving the 18°C temperature. Similarly, since the SW 2 powerhouse discharge (85 cms) was lower than the SW 1 powerhouse discharge (135 cms), SW 2 required lower spillway discharge rates than SW 1. In order to meet the temperature target in SW 3, higher powerhouse discharges were required (Figure 41). At the end of the 60-day spillway release period, SW 1 and SW 2 temperatures decreased about 5°C to about 14°C (Figures 39 and 40), while SW 3 temperatures dropped about 3.5°C (Figure 41).

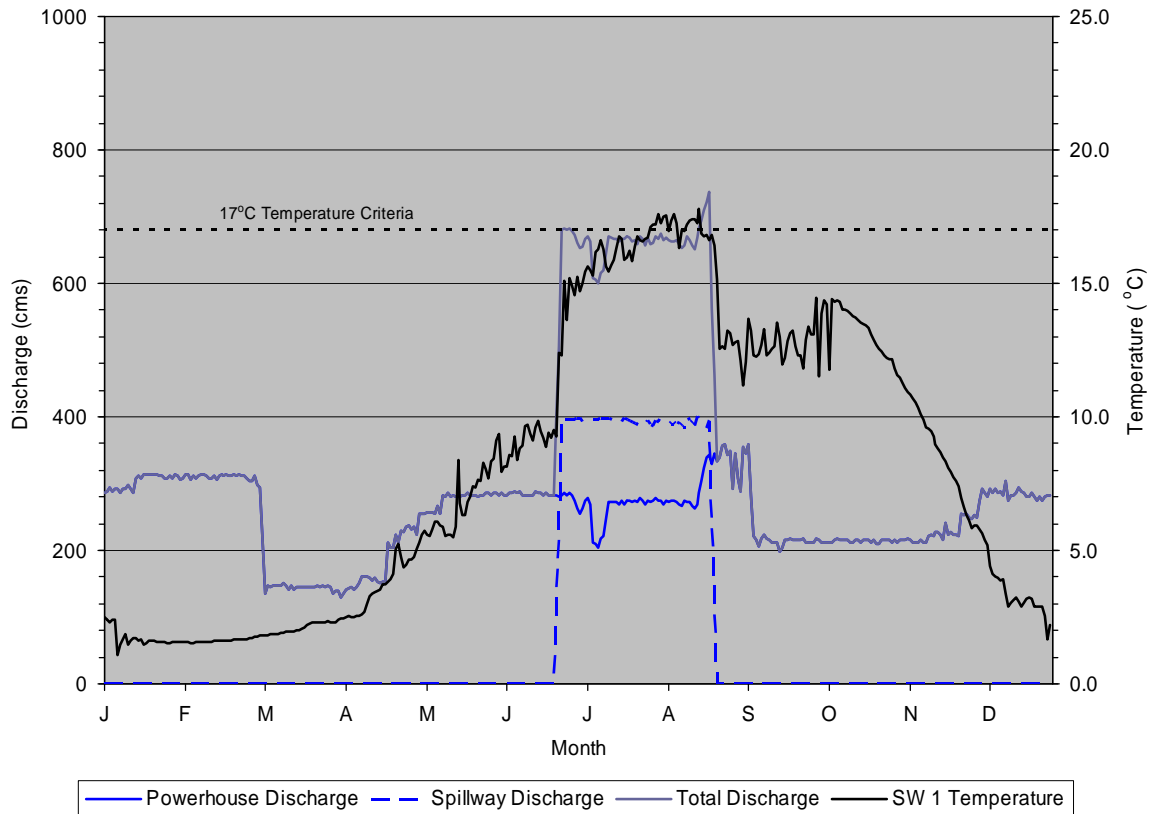
Since spillway and powerhouse releases varied among the Spillway Alternative simulations, the dates that Frazer Rapids temperatures (Figure 42) achieved 18°C with some consistency varied as well. SW 1 temperatures consistently reach 18°C with limited fluctuation after about July 9, while SW 2 temperatures reach 18°C after July 6. SW 3 temperatures at Frazer Rapids do not consistently reach 18°C because spillway discharges did not adequately raise river temperatures in the simulation. River temperatures in SW 3 do reach 18°C around July 9 and August 1.



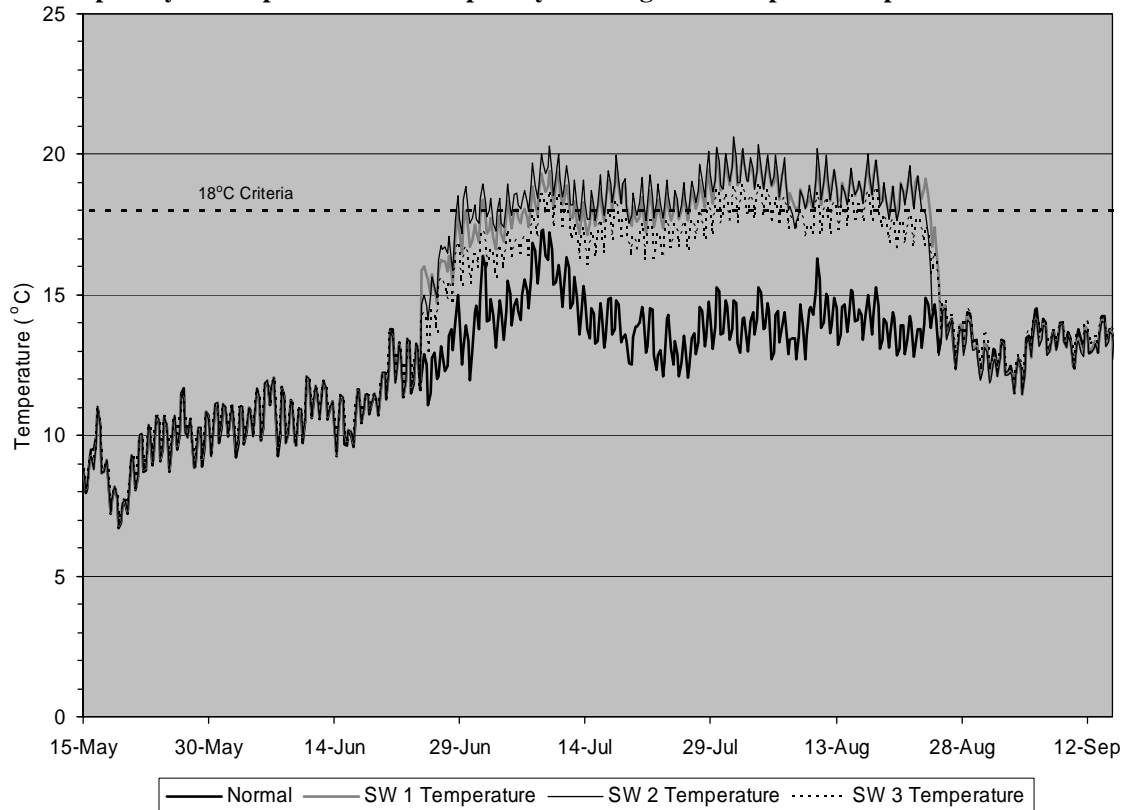
**Figure 39. Spillway Alt 1: powerhouse and spillway discharge and computed temperature bl Fort Peck Dam.**



**Figure 40. Spillway Alt 2: powerhouse and spillway discharge and computed temperature bl Fort Peck Dam.**



**Figure 41. Spillway Alt 3: powerhouse and spillway discharge and computed temperature bl Fort Peck Dam.**

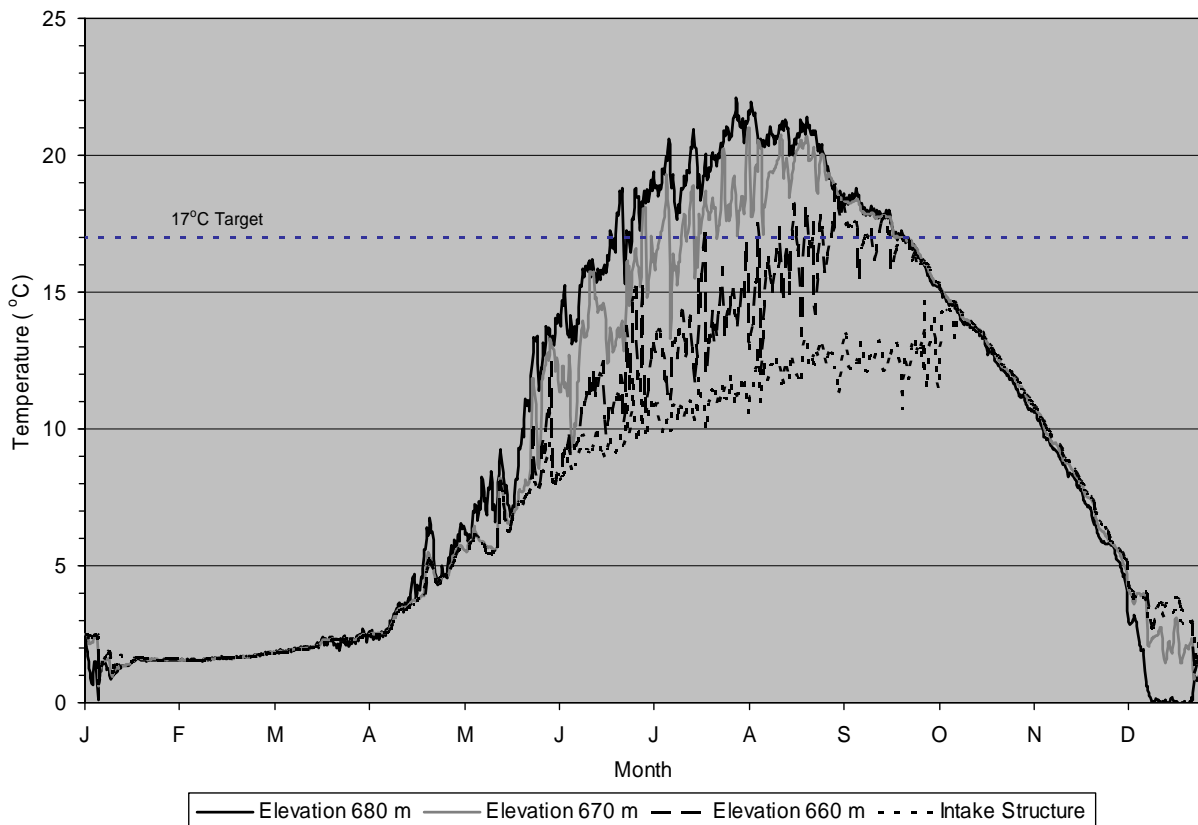


**Figure 42. Comparison of Spillway Alternative simulated river temperatures at Frazer Rapids, MT.**

## 4.2 Selective Withdrawal Releases

The Baseline Simulation indicates lake water near the existing intake structure at elevation 638.6 m (2095 ft) never reaches the 17°C temperature target (Figure 43); however, it reaches the target temperature at higher elevation (shallower depths) in the lake. At the dam water reaches 17°C on June 21 near elevation 680 m and on July 1 at elevation 670 m. In the Baseline Simulation, the 17°C isotherm reaches a maximum depth of 23.3 m (76.5 ft) at elevation of 659.1 m (2162.4 ft) on September 19 (Table 6).

A second method of releasing warm water from Fort Peck Lake is by selectively withdrawing water from a selective withdrawal intake tower constructed on or by the existing Fort Peck Lake tunnel intake structure. Dam releases combining selective withdrawal water from shallower reservoir depths and the existing powerhouse intake structure will increase water release and downstream river temperatures. A major advantage of a selective withdrawal tower is that all water released from the lake would pass through the powerhouse utilizing the power generating capacity of the water releases. The following simulations evaluate the effectiveness of passing water through the selective withdrawal tower at two elevations over varied time periods, and the combinations of flow needed to meet temperature targets.



**Figure 43. Typical Fort Peck Lake simulation (1998) temperature time series at three proposed intake levels and the powerhouse intake structure.**

### 4.2.1 Selective Withdrawal Analysis

The tower selective withdrawal analysis included lake simulations to determine the temperature of water released from Fort Peck Dam through the existing and tower outlets, and

simulations of the Missouri river downstream of Fort Peck to determine river temperatures reached at Frazer Rapids, MT. Selective withdrawal simulations at the Fort Peck intake were performed using two structures simultaneously:

- 1) the existing powerhouse intake structure at elevation 638.6 m (2095 ft), and
- 2) a selective tower withdrawal (TW) structure with intake elevations of 680 m (2231 ft) and 670 m (2198.2 ft) evaluated separately.

Dam releases were made using a combination of discharges from the normal structure and the tower structure, and the tower structure alone during time periods when 17°C water could be withdrawn. Flow rates were adjusted in the structures to achieve 17°C at the dam outlet for various time periods. Table 11 outlines how the selective withdrawal simulations were performed.

**Table 11. Tower selective withdrawal (TW) simulation scenarios.**

Simulation	Existing Structure Discharge cms (cfs)	Tower Structure Elevation m (ft)	Tower Structure Discharge cms	Tower Withdrawal Start Date	Tower Withdrawal Duration days
TW 1	85 (3000)	680 (2231.0)	normal <sup>a</sup> – 85 cms	June 29	90
TW 2	85 (3000)	680 (2231.0)	normal – 85 cms	June 1	130
TW 3	0 (0)	680 (2231.0)	normal	June 1	130
TW 4	85 (3000)	670 (2198.2)	normal – 85 cms	July 8	90
TW 5	85 (3000)	670 (2198.2)	normal – 85 cms	June 1	130
TW 6	0 (0)	670 (2198.2)	normal	June 1	130

<sup>a</sup> 1998 normal powerhouse discharge.

#### 4.2.2 Selective Withdrawal Results

Simulations TW 1, TW 2, and TW 3 used the 680-m (2231 ft) elevation tower withdrawal structure in combination with the existing structure. In the TW 1 simulation, existing intake discharges were reduced to 85 cms (3000 cfs) on June 29 while the remainder of the existing discharge was routed through the tower structure (Figure 44). The same discharge scheme was applied in TW 2, only discharge through the tower was initiated on June 1 and carried into early October (Figure 45). The result of earlier releases in TW 2 was a smoother increase in dam discharge temperatures than in TW 1. TW 1 and TW 2 discharge temperatures were the same between June 29 and September 27, reaching or exceeding 17°C from late July through late August.

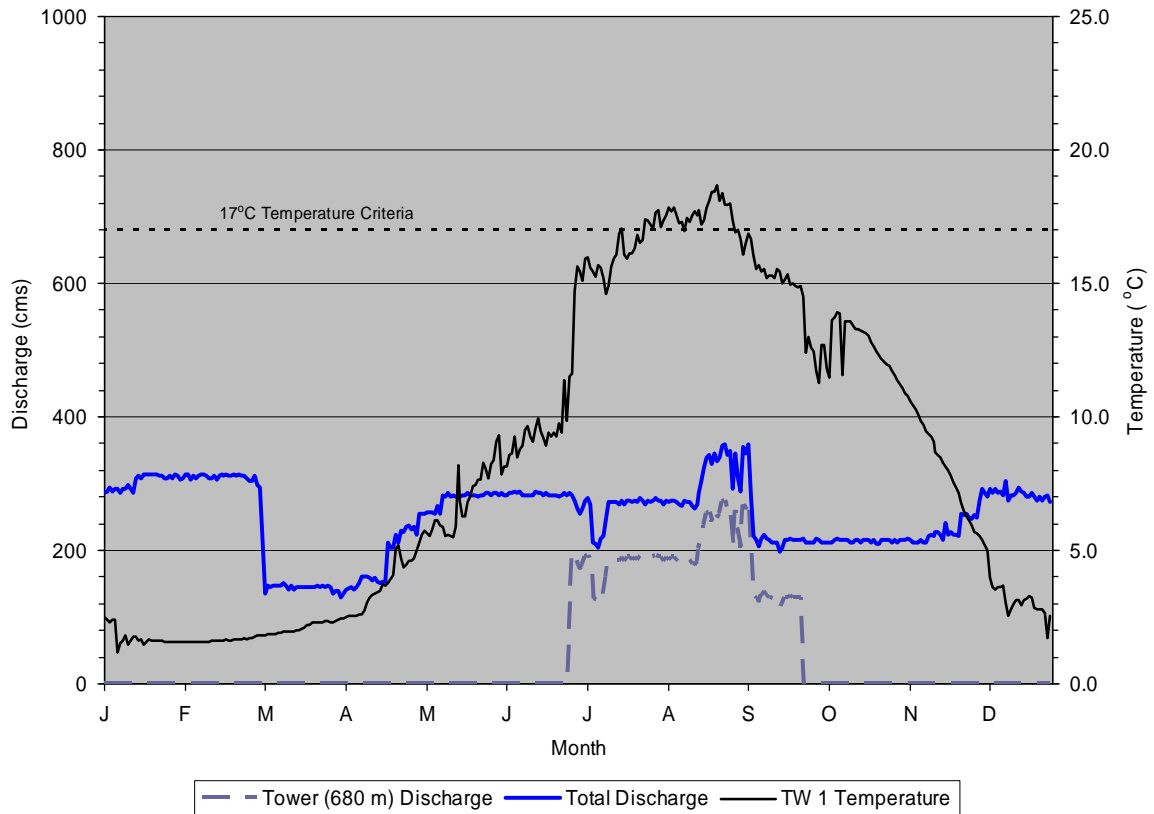
In the TW 3 simulation all dam discharges were routed through the 680-m tower structure from June 1 through early October, greatly increasing the temperatures released from the dam (Figure 46). Temperatures reached 17°C by late June and persisted through mid-September reaching 21°C at times during the summer season.

The TW 3 simulation provided the best chance for reaching the 18°C temperature target at Frazer Rapids, MT, since all release water during the release period was originating from near the 680-m lake elevation. Temperatures at Frazer Rapids were consistently above 18°C from the end of June to the beginning of September (Figure 47). Simulations TW 1 and TW 2 also produced 18°C temperatures but they were generally 2 to 3°C lower than TW 3 and occurred over a shorter period of time.

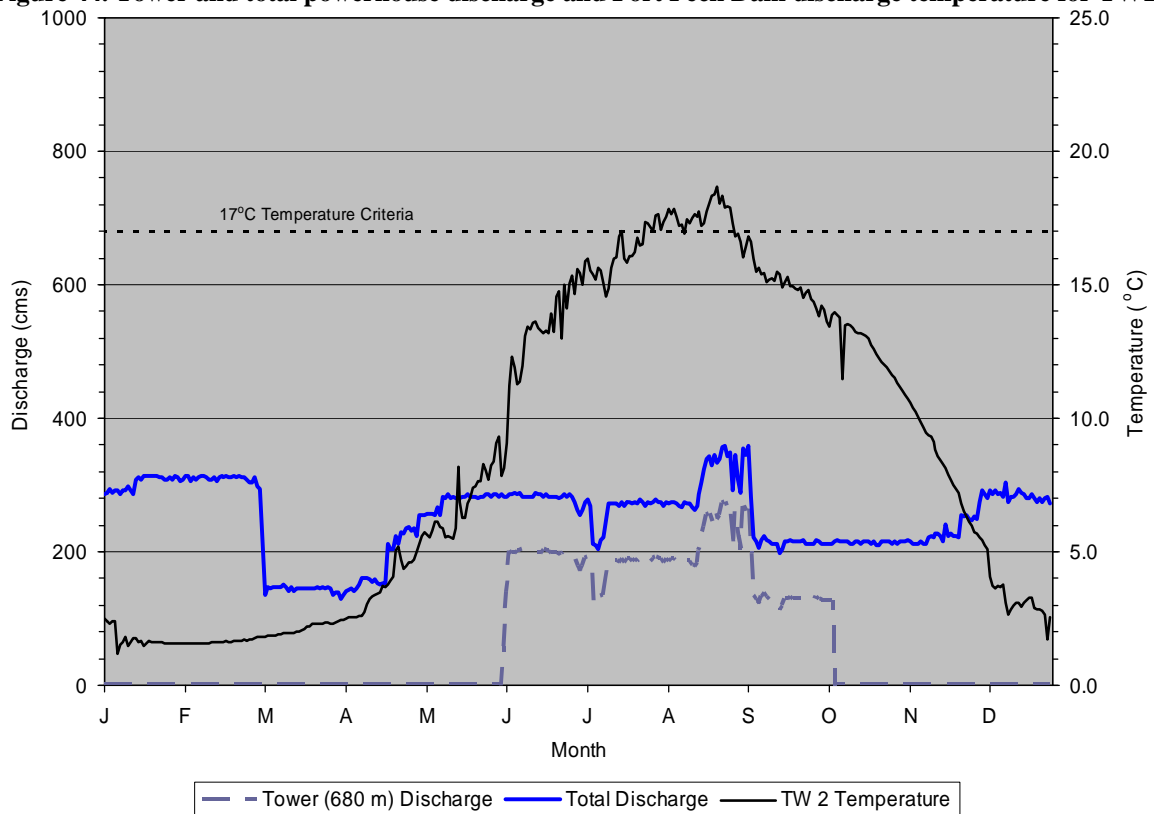
Simulations TW 4, TW 5, and TW 6 used the 670-m (2231 ft) elevation tower with structure in combination with the existing structure. TW 4, TW 5, and TW 6 releases mirrored TW 1, TW 2, and TW 3 releases, respectively. Dam discharges through the deeper tower withdrawal intake produced lower release temperatures for a shorter period of time. TW 4 and TW 5 release temperatures reached 17°C (Figures 48 & 49) only in August, which is the peak heating time for Fort Peck Lake.

As in TW 3, TW 6 release temperatures are noticeably better than TW 1 and TW 2 temperatures (Figure 50). TW 6 temperatures reached 17°C by early July and persisted through early to mid-September; however, temperatures were not as warm as TW 3 temperatures.

The 670 m (2198.2 ft) elevation tower structure provides a second alternative elevation when lake pool elevations are lower than 680 m (2231 ft). The 670-m tower structure simulations were performed when the pool was well above 680 m, so they demonstrate that temperatures cooler than the higher outlet will be released through the dam from the lower outlet. Temperatures at Frazer Rapids, MT, intermittently reached 18°C in TW 4 and TW 5, while TW 6 consistently reached or exceeded 18°C from early July to late August (Figure 51).

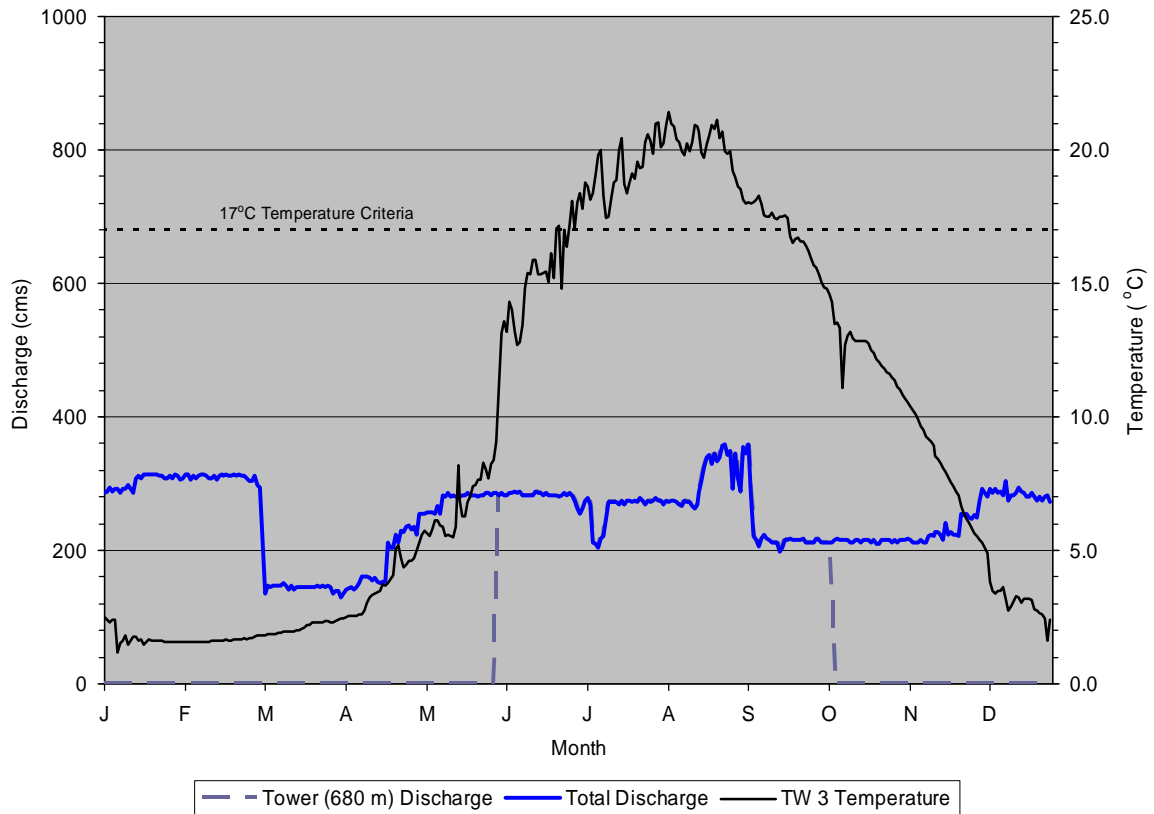


**Figure 44. Tower and total powerhouse discharge and Fort Peck Dam discharge temperature for TW1.**

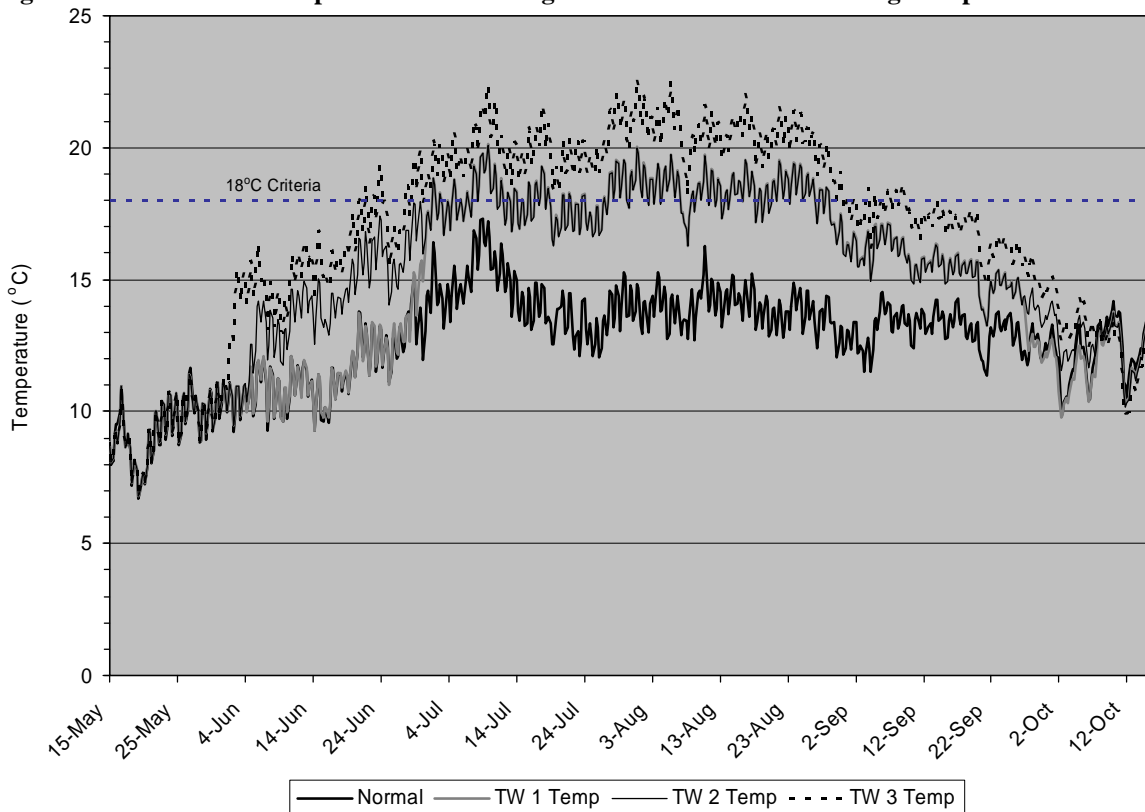


**Figure 45. Tower and total powerhouse discharge and Fort Peck Dam discharge temperature for TW2.**

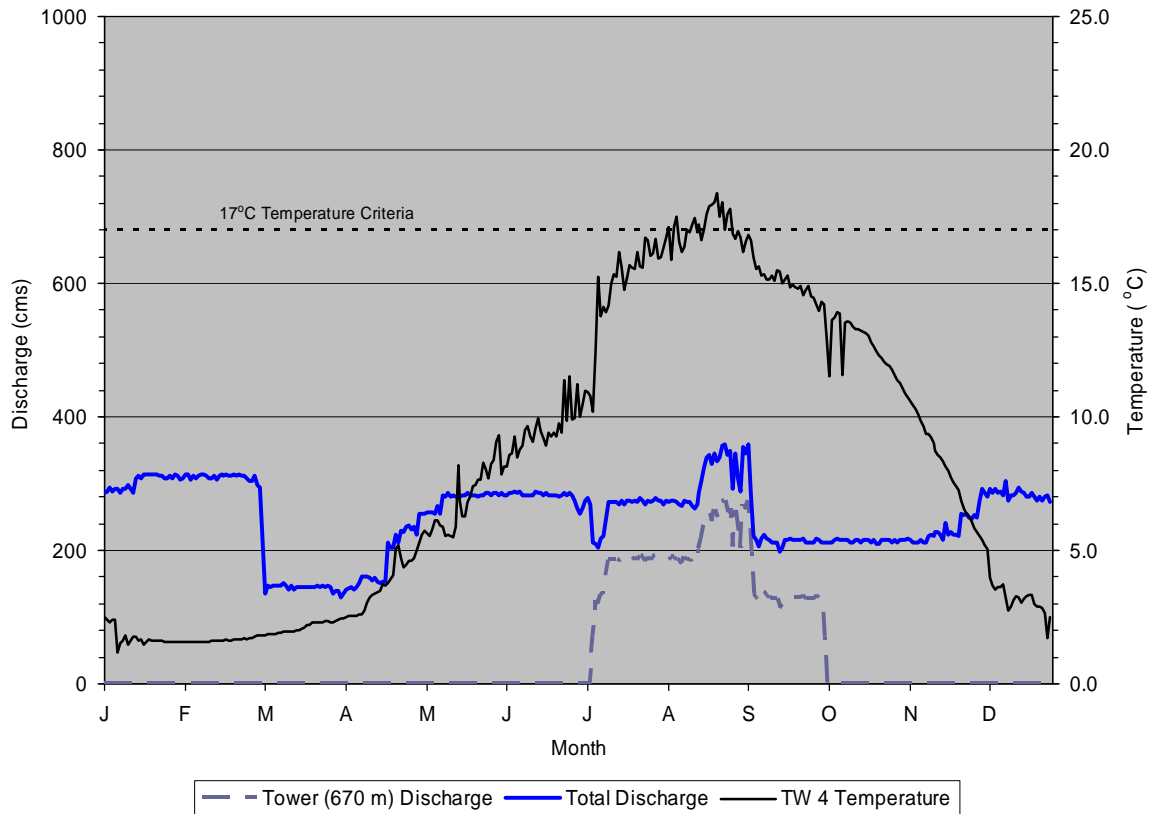




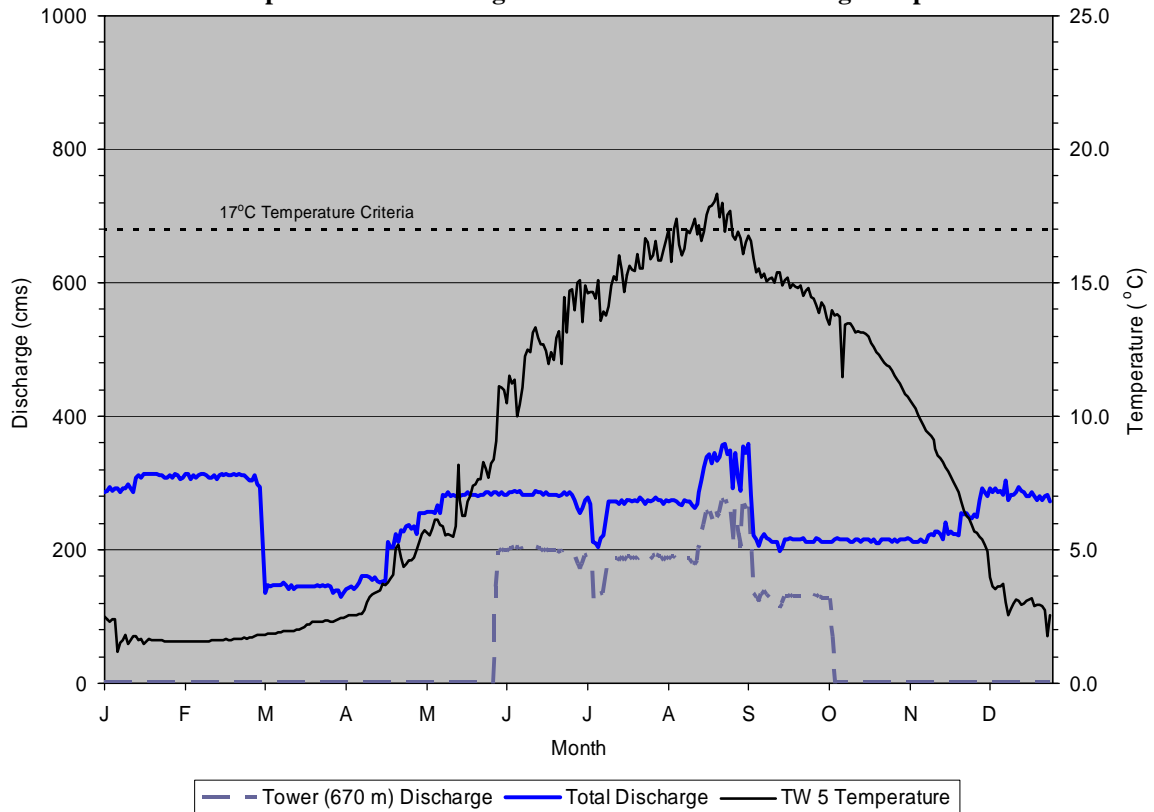
**Figure 46. Tower and total powerhouse discharge and Fort Peck Dam discharge temperature for TW3.**



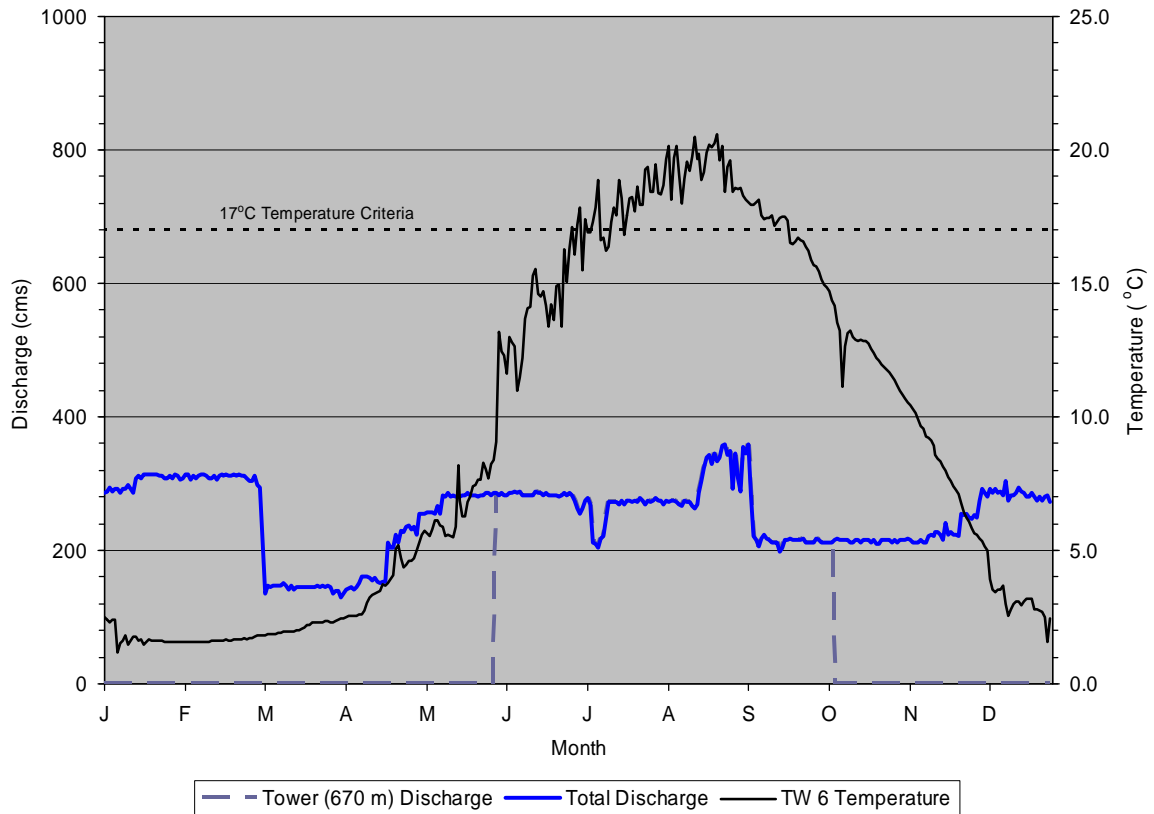
**Figure 47. Tower Withdrawal Alternative (Elev. 680 m) simulated river temperatures at Frazer Rapids, MT.**



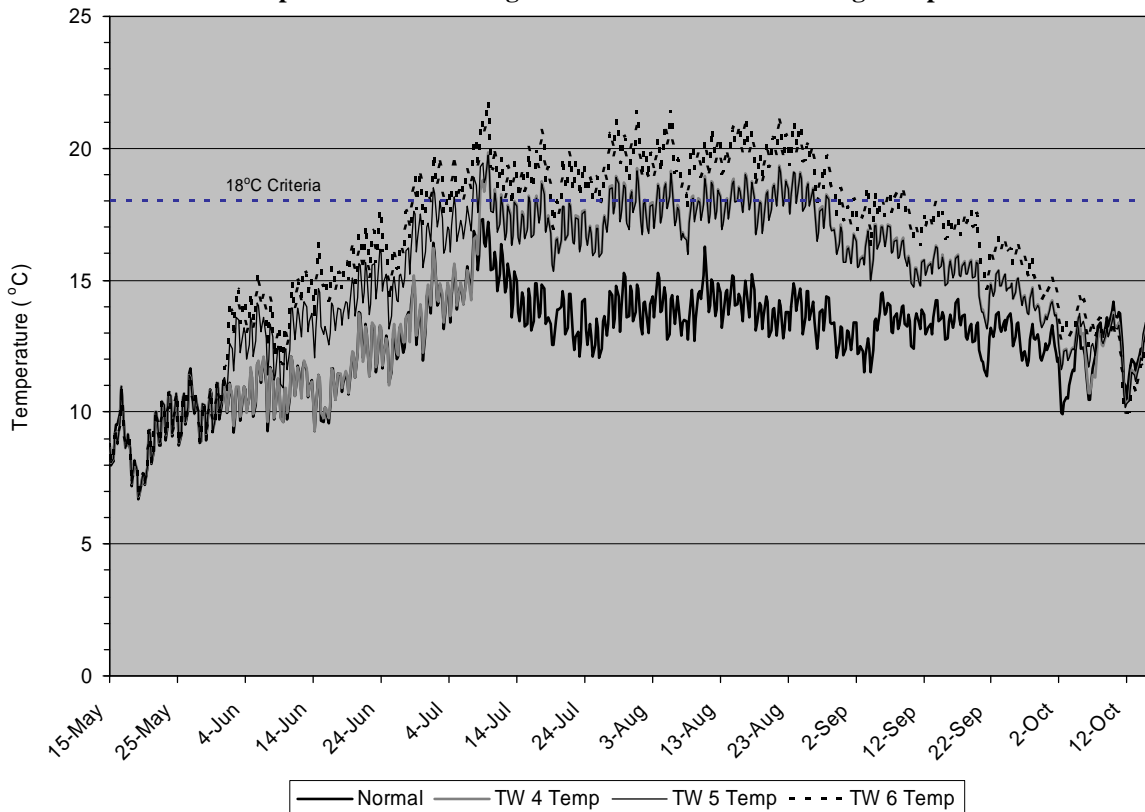
**Figure 48. Tower and total powerhouse discharge and Fort Peck Dam discharge temperature for TW4.**



**Figure 49. Tower and total powerhouse discharge and Fort Peck Dam discharge temperature for TW5.**



**Figure 50. Tower and total powerhouse discharge and Fort Peck Dam discharge temperature for TW6.**



**Figure 51. Tower Withdrawal Alternative (Elev. 670 m) simulated river temperatures at Frazer Rapids, MT.**

## 4.3 Summary of Alternatives

### 4.3.1 Lake Performance

The discharge, volume, and elevation performance of Fort Peck Lake is summarized below in Table 12. FT releases were made for 42 and 60 days while SW releases were made for 60 to 61 days. Compared to normal releases, powerhouse releases were greatly reduced in all FT and SW simulations with the exception of SW 3 in order to achieve the 17°C release and 18°C Frazer Rapids temperature target. As a result, the greatest discharges were made in SW 3, which needed higher spillway discharges to meet the target temperatures.

**Table 12. Reservoir performance under normal, full test, spillway alternative, and selective withdrawal alternative simulations.**

Simulation	Spillway Release Dates			Average Discharge During Spillway Releases, m <sup>3</sup> /s (ft <sup>3</sup> /s) <sup>a</sup>			Annual Discharge Volume million ac ft			End of Year Elevation m (ft)
	Begin	End	Days	Powerhouse	Spillway	Total	Spillway Total	Total <sup>b</sup>	Excess of Normal <sup>c</sup>	
Baseline				274 (9675)	0 (0)	274	0.00	6.44		681.7 (2236.5)
FT 1	6/21	8/2	42	120 (4236)	363 (12824)	483	1.09	7.07	0.63	680.7 (2233.3)
FT 2	6/21	8/20	60	166 (5870)	336 (11863)	502	1.44	7.40	0.96	680.2 (2231.6)
FT 3	6/21	8/20	60	137 (4842)	355 (12539)	492	1.52	7.36	0.92	680.3 (2232.0)
SW 1	6/23	8/23	61	137 (4842)	335 (11813)	472	1.45	7.29	0.85	680.4 (2232.3)
SW 2	6/23	8/22	60	89 (3133)	210 (7408)	299	0.90	6.52	0.08	681.5 (2235.9)
SW 3	6/23	8/23	61	274 (9675)	379 (13392)	653	1.65	8.06	1.62	679.2 (2228.3)
				Structure 1	Structure 2					
TW 1	6/28	9/25	90	85 (3000)	183 (6474)	268				
TW 2	6/1	10/7	130	85 (3000)	181 (6402)	266	0.00	6.44	0.00	681.7 (2236.5)
TW 3	6/1	10/7	130	0 (0)	266 (9386)	266				
TW 4	7/7	10/4	90	85 (3000)	178 (6277)	263				
TW 5	6/1	10/7	130	85 (3000)	182 (6425)	267	0.00	6.44	0.00	681.7 (2236.5)
TW 6	6/1	10/7	130	0 (0)	268 (9455)	268				

<sup>a</sup> Average releases during spillway or structure release period.

<sup>b</sup> Total volume = Spillway total volume + Powerhouse total volume (not listed in table).

<sup>c</sup> Annual Volume in excess of the Normal Dam Release volume.

Total discharge volumes exceeded the Baseline (1998) total discharge volume of 6.44 million acre feet (MAF) in all FT and SW alternatives. FT 2 and SW 3 scenarios released the greatest volumes, while SW 2 released the least volume of the six scenarios. FT 2 spilled 0.96 MAF of water in excess of normal total releases. Of the total release, 1.44 MAF was passed through the spillway, and 5.96 MAF was passed through the powerhouse which was 0.48 MAF below the normal annual powerhouse discharge of 6.44 MAF. SW 3 spilled 1.62 MAF of water in excess of normal total releases, but maintained normal discharges through the powerhouse. The SW 2 simulation released only 0.08 MAF of water in excess of the normal release; however, annual powerhouse releases were 5.62 MAF or 0.82 MAF below the normal year release.

At the end of the year pool elevations were lower than the Baseline end-of-year elevation of 681.7 m (2236.5 ft). FT elevations ranged from 680.7 to 680.2 m (2233.3 to 2231.6 ft) representing elevation declines of 1.0 to 1.5 m (3.2 to 4.9 ft). SW elevations ranged from 681.5 to 679.2 m (2235.9 to 2228.3 ft) representing elevation declines of 0.2 to 2.5 m (0.6 to 8.2 ft).

FT 2 and SW 3 demanded the most lake water while FT 1 and SW 2 demanded the least lake water.

TW releases were made for 90 and 130 days with 85 cms (3000 cfs) passing through the existing intake structure (Structure 1) in TWs 1,2,4,5, and 0 cms passing through Structure 1 in TWs 3 and 6. The total discharge, which all passed through the powerhouse, did not exceed the normal powerhouse discharge in any of the simulations, so the reservoir volume and pool were not adversely impacted by temperature releases through the selective withdrawal towers.

#### 4.3.2 River Temperature Performance

The time and temperature performance of Missouri River water at Frazer Rapids as affected by spillway and selective withdrawal releases is summarized in Table 13. 18°C temperatures in FT simulations were first present at Frazer Rapids on June 24 and last present in early to mid-August, and they were achieved for the greatest number of days (37) during the FT 3 simulation at an average temperature of 18.1°C.

**Table 13. Missouri River temperature performance at Frazer Rapids, MT, under normal, full test, spillway alternative, and selective withdrawal alternative simulations.**

Simulation	Time Analysis of 18°C Target			Temperature over Release Period (°C)	
	1 <sup>st</sup> Date	Last Date	Days Achieved	Maximum	Average
Baseline	---	---	0	17.3	14.0
FT 1	6/24	8/3	24	20.4	18.0
FT 2	6/24	8/17	25	20.4	17.8
FT 3	6/24	8/20	37	20.4	18.1
SW 1	6/29	8/24	41	20.3	17.7
SW 2	6/28	8/23	47	20.6	18.2
SW 3	7/8	8/18	12	19.0	17.0
TW 1	7/2	8/28	37	20.2	17.3
TW 2	7/2	8/28	36	20.1	16.2
TW 3	6/22	9/9	70	22.6	18.0
TW 4	7/8	8/29	21	19.8	16.6
TW 5	7/2	8/29	19	19.8	15.9
TW 6	6/29	9/9	62	21.8	17.4

SW 1 and SW 2 temperatures achieved 18°C at Frazer Rapids beginning after June 28 and ending August 24 for 41 and 47 days, respectively. Average SW 1 and SW 2 temperatures over the release period were 17.7 and 18.2°C, respectively. SW 3 temperatures reached 18°C on July 8 but for only 12 days throughout the release period at an average release temperature of 17°C.

The number of days that 18°C was achieved at Frazer Rapids, MT, for simulations TW 1 and TW 2 were 37 and 36, respectively; while average temperatures were 17.3 and 16.2°C. The lower average temperature exhibited in TW 2 is due to a longer release period over which temperatures below the 17°C target were released. The number of days that 18°C was achieved in simulation TW 3 was 70 beginning June 22 and ending September 9, because all powerhouse

releases were drawn from the tower intake near elevation 680 m rather than a combination of the two intakes. The average temperature over the 130 release period was 18°C.

The number of days that 18°C was achieved at Frazer Rapids, MT, for simulations TW 4 and TW 5 were 21 and 19, respectively; while average temperatures were 16.6 and 15.9°C. The number of days that 18°C was achieved in simulation TW 3 was 62 days beginning June 29 and ending September 9. The average temperature over the 130 release period was 17.4°C.

## 5 CONCLUSIONS

### 5.1 Existing Conditions Analysis

One of the primary purposes of this study was to develop a calibrated water temperature model of Fort Peck Lake and the Missouri River downstream to Culbertson, MT, then develop baseline temperature conditions to compare management changes against. Baseline temperature conditions were developed using 1998 lake and river hydrodynamic data and 1994 meteorological data. The following conclusions were made from the lake and river model Baseline Simulation and parameter simulations.

Since average Missouri River temperature increases from Fort Peck Dam to Frazer Rapids, MT were about 1°C, the warm water target temperature in Fort Peck Lake was designated as 17°C. In the Baseline Simulation 17°C temperatures develop at the lake surface and spillway crest elevation between June 20 and 22 and persist for 96 days until late September. Lake water near the existing intake structure does not reach 17°C during any simulation year. Also temperatures in the lacustrine zones of the Big Dry Arm and main branch of Fort Peck Lake are not appreciably different.

The Baseline Simulation revealed that maximum 30-day average river temperature at Frazer Rapids, MT, was 14.3°C during August. The June through August average temperature at Frazer Rapids was 13.2°C, and the peak daily temperature was 17.3°C. The daily temperature never reached 18°C at Frazer Rapids.

The influence of lake inflow, outflow, pool elevation, and environmental air temperature were evaluated by simulating 90<sup>th</sup> percentile, median and 10<sup>th</sup> percentile parameters in the calibrated lake and river models. Of the four parameters evaluated, pool elevation and environmental temperature had the greatest influence on lake and river temperatures. Elevations near the 10<sup>th</sup> percentile produced higher lake release temperatures than median and 90<sup>th</sup> percentile pool elevations. In addition, high environmental temperatures cause the lake to heat more rapidly, in effect raising the temperature of release water. The same relationships applied to the river temperature simulations. Parameter variations, however, did not affect lake and river temperatures enough to achieve the 18°C temperature target at Frazer Rapids.

### 5.2 Alternative Management Analysis

Lake discharge and volume and river temperature were the main factors considered in this study in evaluating the effectiveness of temperature release scenarios. Decreased generator efficiency and power generation or geotechnical stability of the spillway may be a consideration; however, these factors were not considered in this study.

Spillway Full Test (FT) and Alternative Spillway (SW) scenarios made great demands on lake water volume and discharge, while Selective Tower Withdrawal (TW) scenarios had no impact to lake volume and discharge. Of the FT scenarios, FT 1 demanded the least volume of water because releases were performed for only 42 days. SW 2 demanded the least volume of water from all FT and SW scenarios because powerhouse discharges were drastically cut allowing warm water spillway discharges to be scaled back. TW scenarios did not make any adverse demands on lake volumes during the simulations.

The number of days that 18°C water temperatures were achieved on the Missouri River at Frazer Rapids, MT, during the release periods was 37 days for FT 3, 47 days for SW 2, 70 days

for TW 3, and 62 days for TW 6. Average temperatures in FT 3 and SW 2 were above 18°C, and TW 3 and TW 6 average temperatures were 18.0 and 17.4°C, respectively. The earliest that 18°C temperatures were achieved at Frazer Rapids was June 22 in TW 3. FT 3 achieved 18°C on June 24 and SW 2 achieved 18°C on June 28.

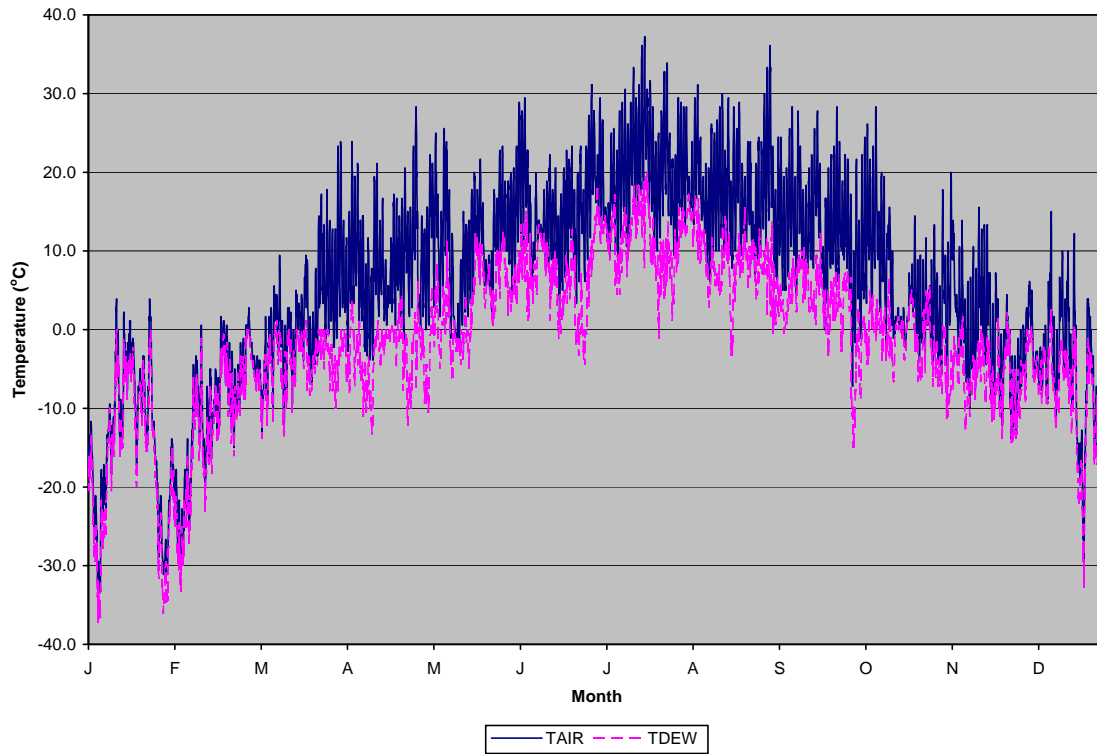
Considering all spillway release options, releases made in a manner similar to SW 2 are the best spillway option because it demands the least lake water volume and produces a high average temperature (18.2°C) over 47 days; however, much of the release water bypasses the powerhouse. Selective tower withdrawal is a good release option because it routes all warm water releases through the powerhouse taking advantage of the discharge water for power generation. Tower withdrawal achieved 18°C temperatures for 70 days when all water was passed through the 680-m (2231-ft) elevation selective withdrawal tower and 37 days when water was passed through the existing and selective withdrawal tower.



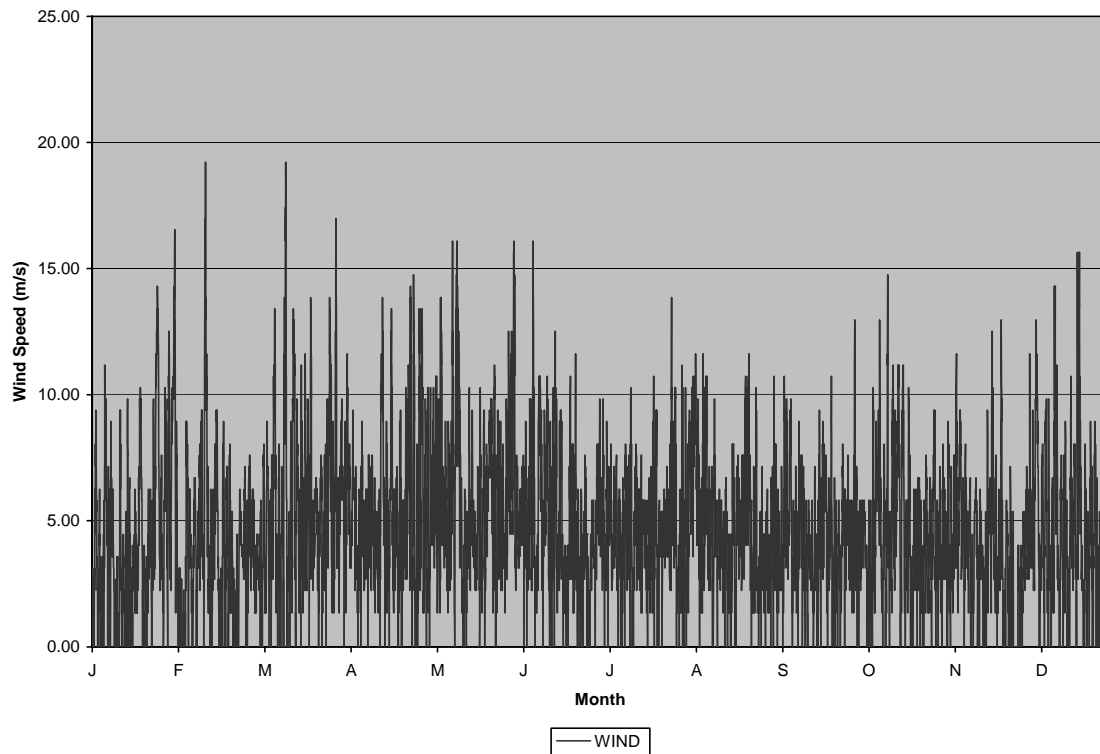
## 6 REFERENCES

- Thornton, K.W., Kimmel, B.L., and Payne, F.E. (eds.). 1990. Reservoir Limnology – Ecological Perspectives. John Wiley & Sons, Inc., New York, New York.
- U.S. Army Corps of Engineers. 1987. Engineer Manual (EM) 1110-2-1201, Engineering and design – Reservoir Water Quality Analysis. U.S. Army Corps of Engineers, Department of the Army, Washington, D.C.
- Cole, T.M., and Wells, S.A. 2003. CE-QUAL-W2: A Two-Dimensional, Laterally Averaged, Hydrodynamic and Water Quality Model, Version 3.2. Instruction Report EL-03-1, U.S. Army Engineering and Research Development Center, Vicksburg, MS.
- U.S. Army Corps of Engineers, Omaha District. 2004. Environmental Assessment – Fort Peck Flow Modification Mini-Test. U.S. Army Corps of Engineers, Department of Army, Omaha, NE.
- U.S. Army Corps of Engineers, Omaha District. 2007. Water Quality Special Study Report – Water Quality Conditions Monitored at the Corps’ Fort Peck Project in Montana during the 3-Year Period 2004 through 2006. U.S. Army Corps of Engineers, Department of Army, Omaha, NE.
- U.S. Fish and Wildlife Service. 2000. Biological Opinion on the Operation of the Missouri River Main Stem Reservoir System, Operation and Maintenance of the Missouri River Bank Stabilization and Navigation Project, and Operation of the Kansas River Reservoir System. U.S. Fish and Wildlife Service, Denver, CO, Fort Snelling, MN.

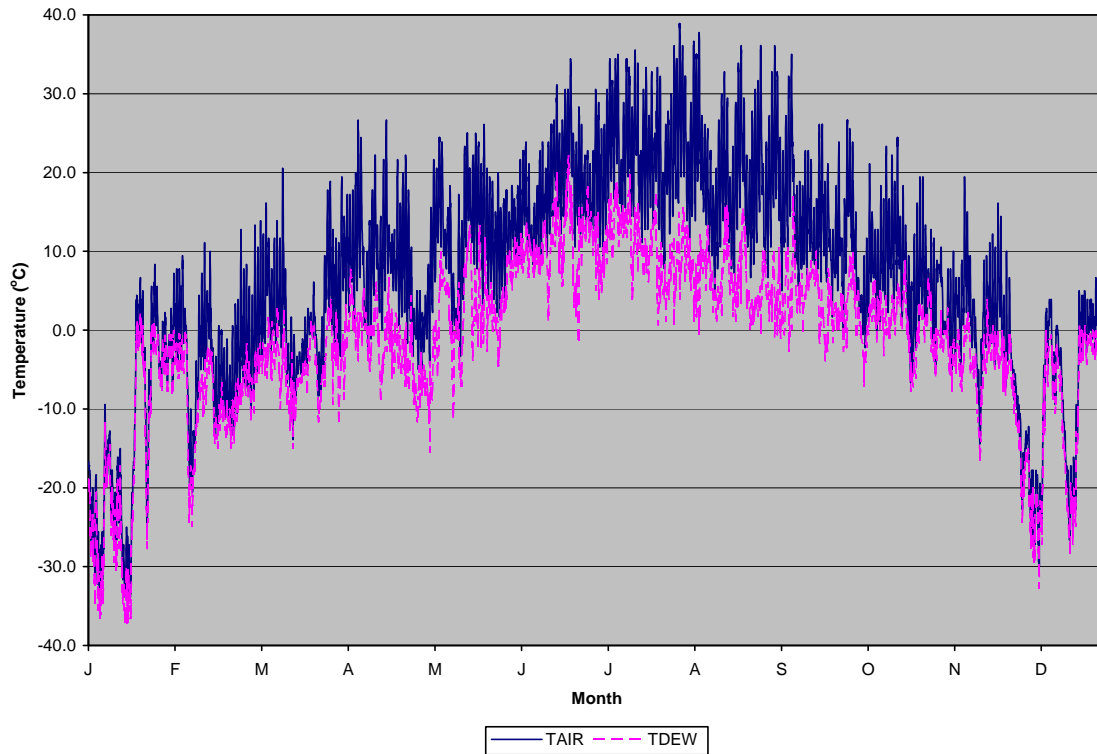
## 7 PLATES



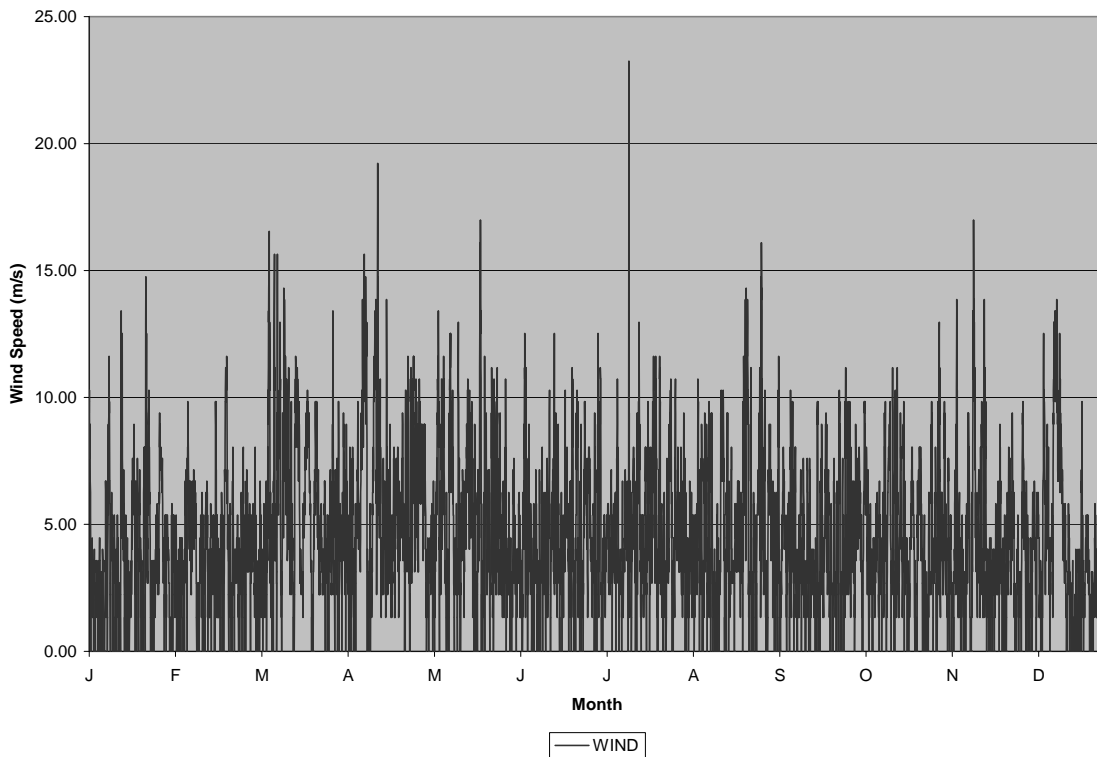
**Plate 1. 2004 Glasgow International Airport (KGGW) hourly air and dew point temperature Celsius.**



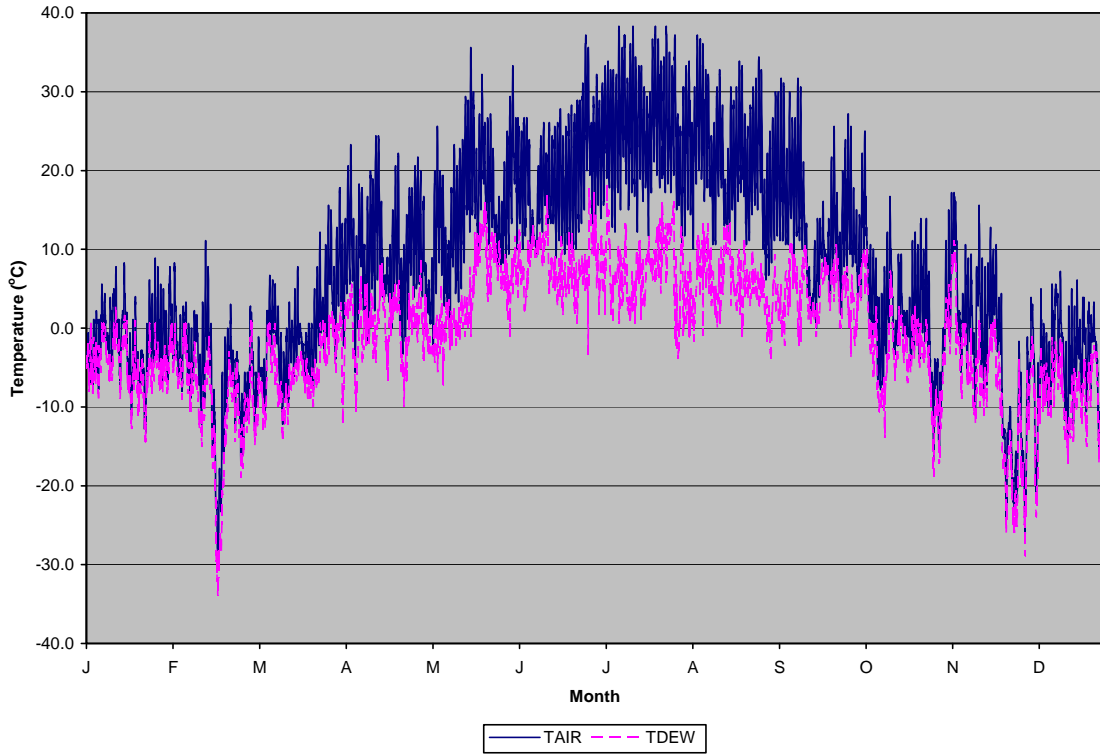
**Plate 2. 2004 Glasgow International Airport (KGGW) hourly wind speed (m/s).**



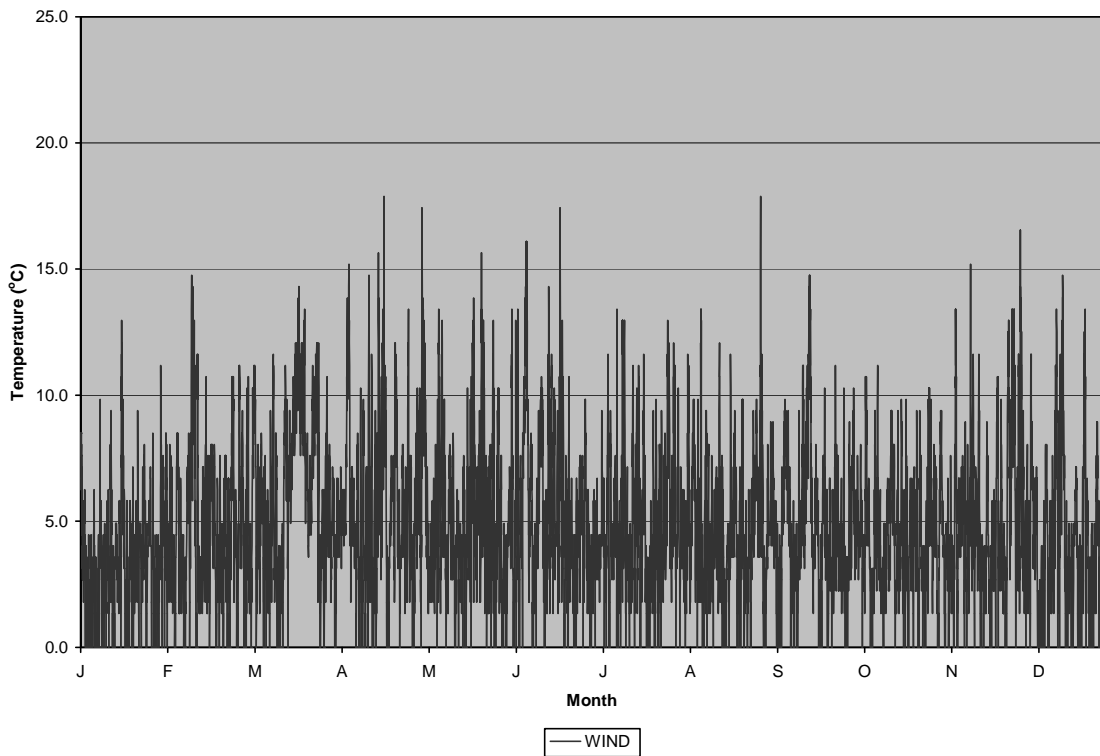
**Plate 3. 2005 Glasgow International Airport (KGGW) hourly air and dew point temperature.**



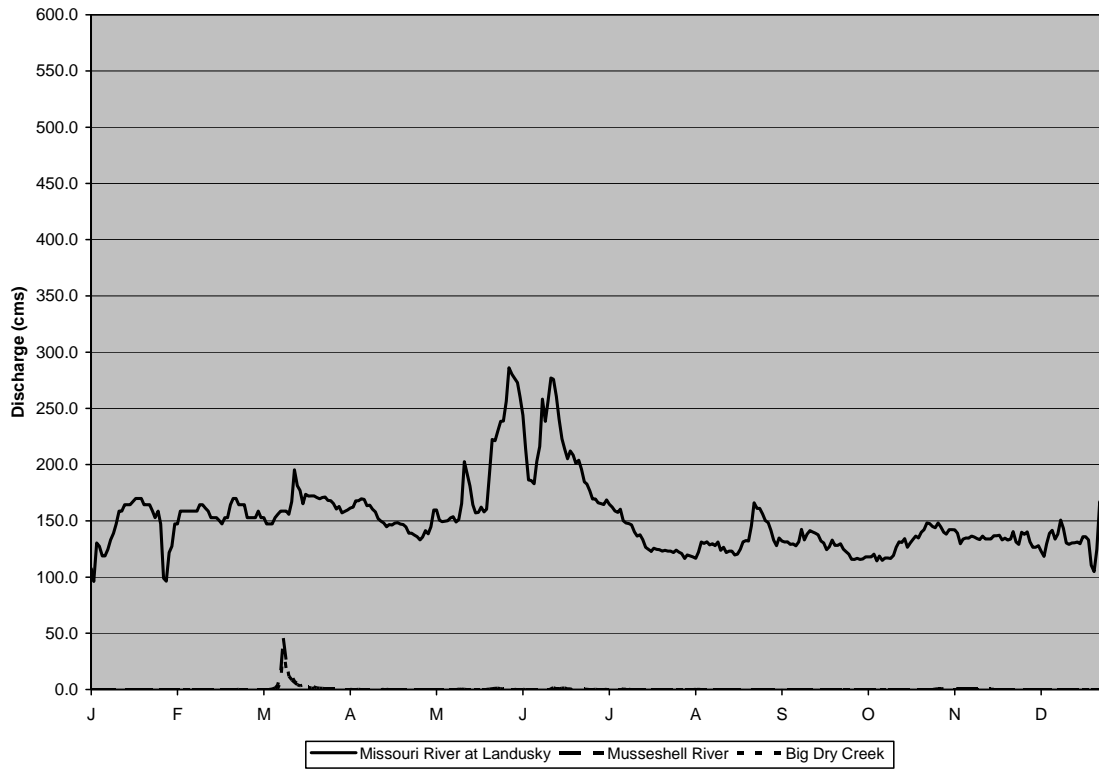
**Plate 4. 2005 Glasgow International Airport (KGGW) hourly wind speed (m/s).**



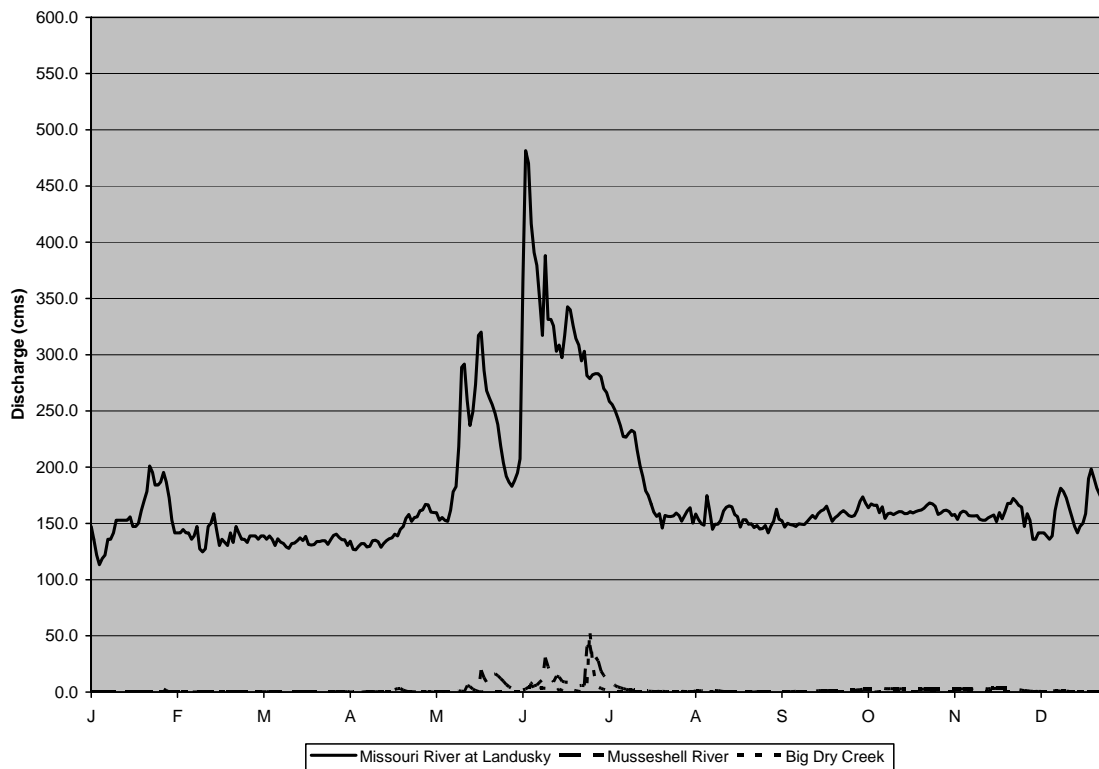
**Plate 5. 2006 Glasgow International Airport (KGGW) hourly air and dew point temperature.**



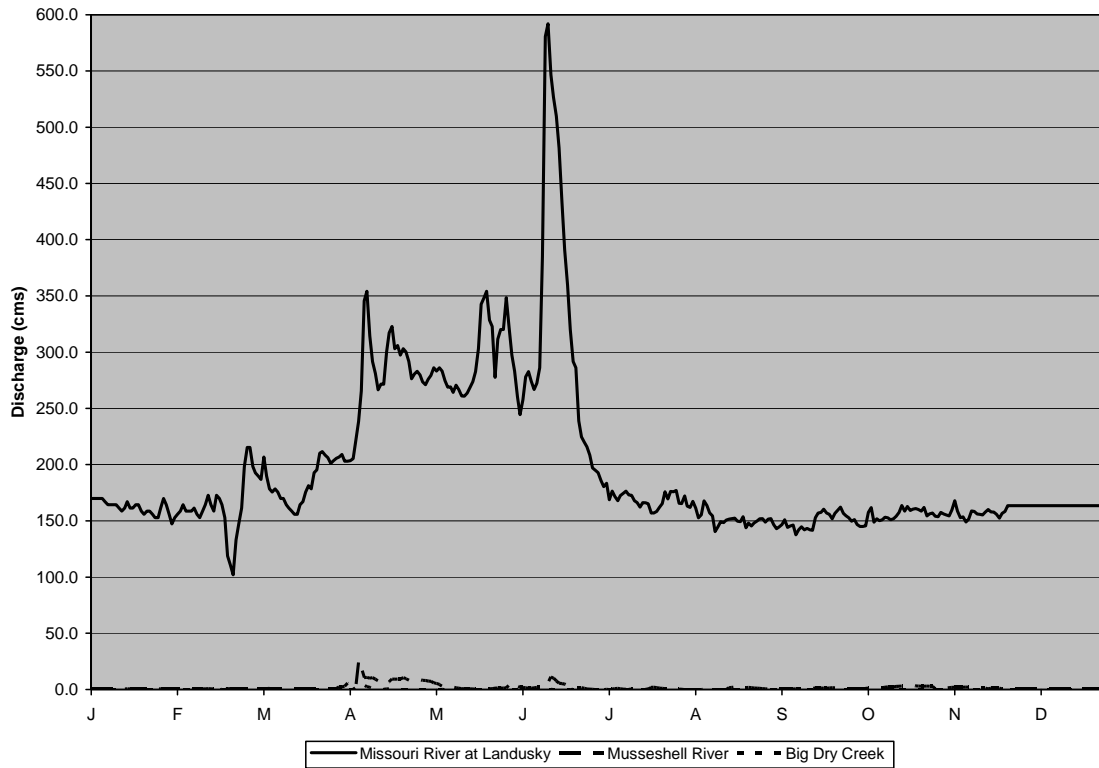
**Plate 6. 2006 Glasgow International Airport (KGGW) hourly wind speed (m/s).**



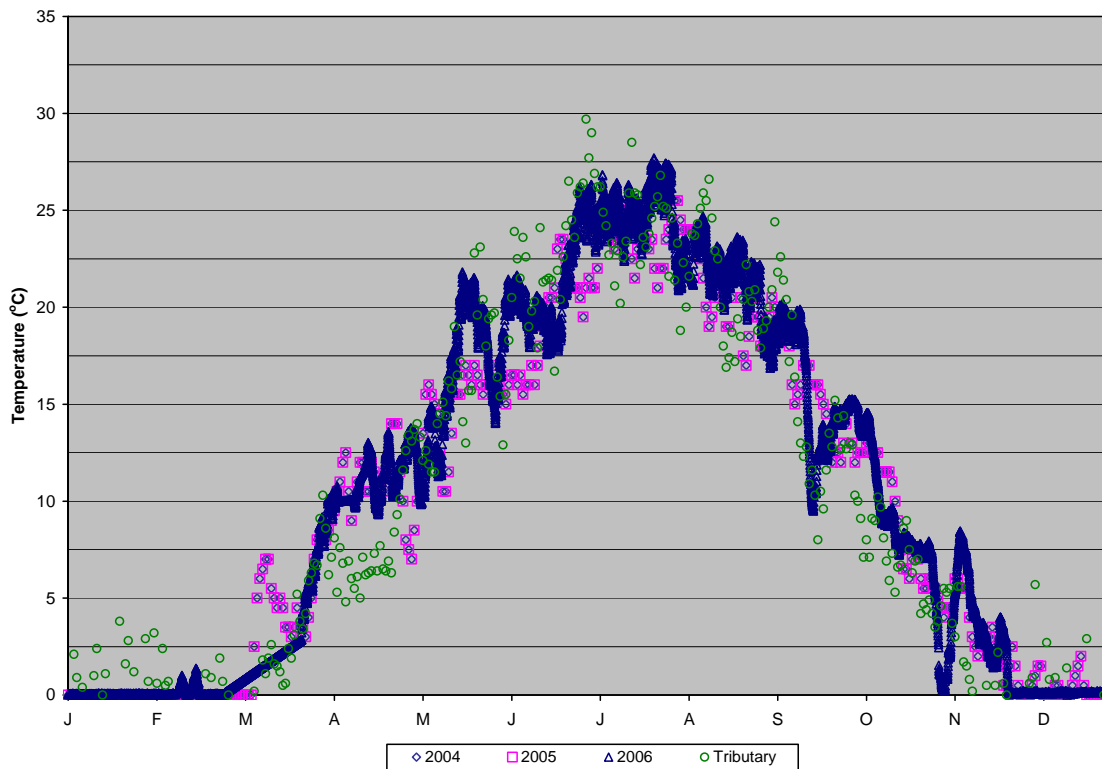
**Plate 7. 2004 Fort Peck Lake inflows.**



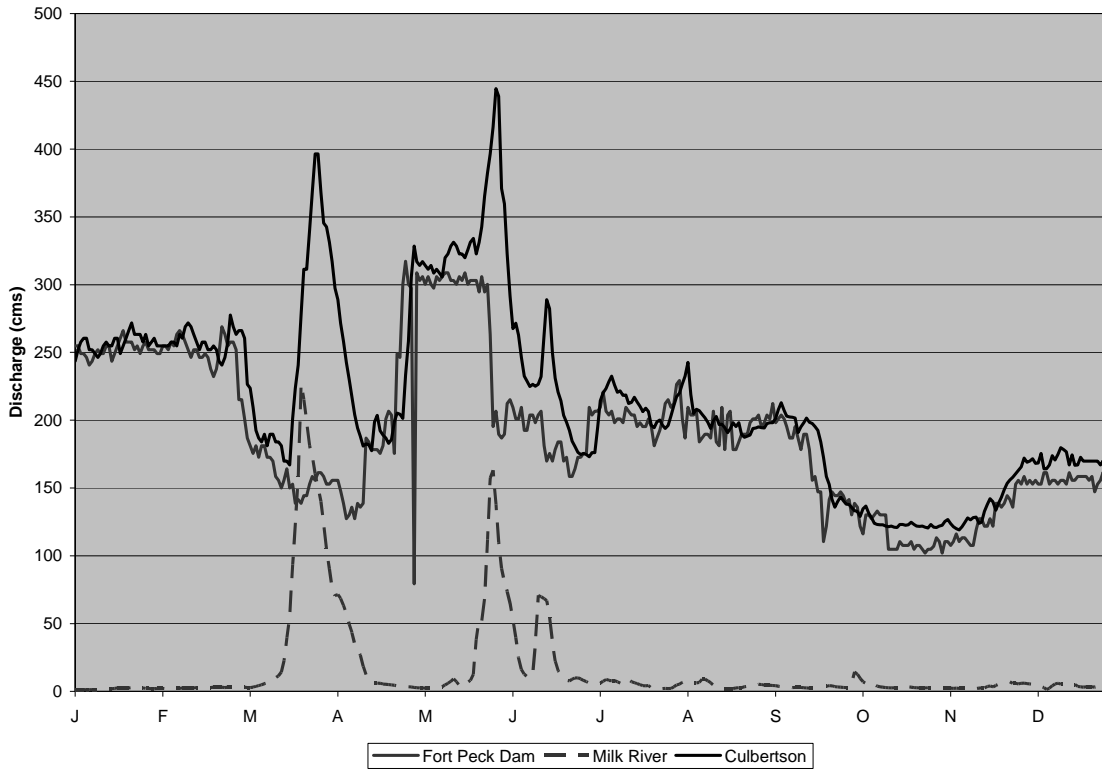
**Plate 8. 2005 Fort Peck Lake inflows.**



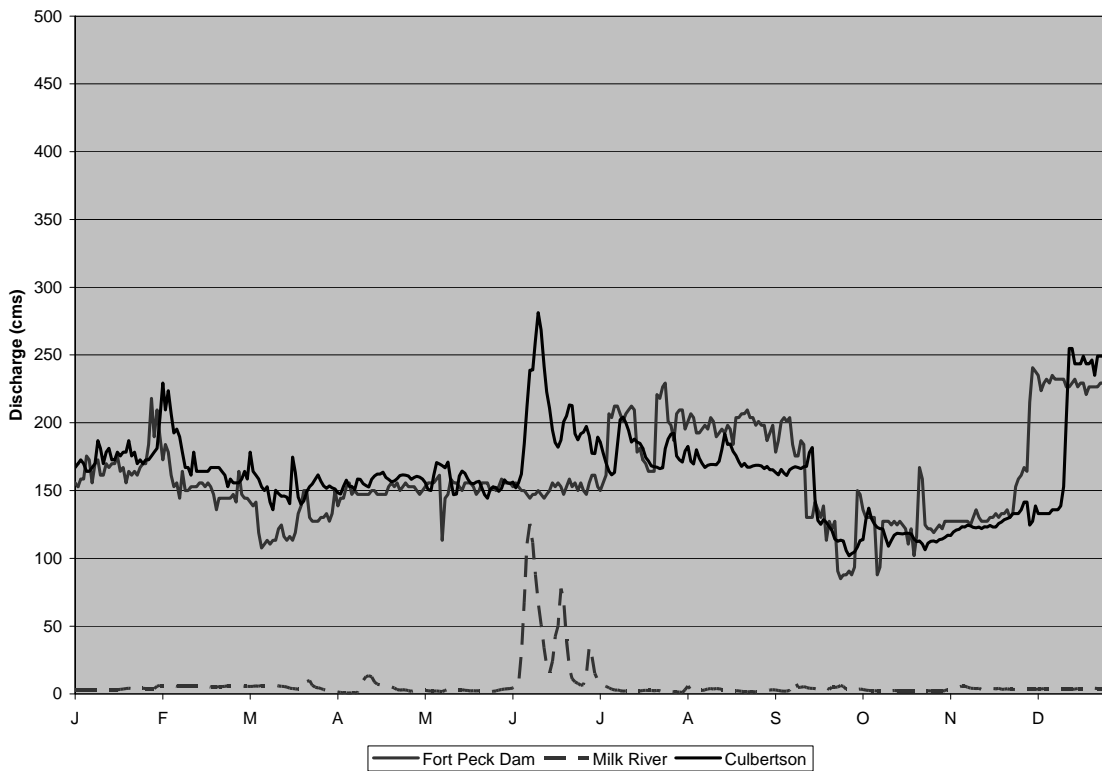
**Plate 9. 2006 Fort Peck Lake inflows.**



**Plate 10. Fort Peck Lake inflow temperatures on the Missouri River at Landusky (2004-2006) and assumed tributary temperatures.**

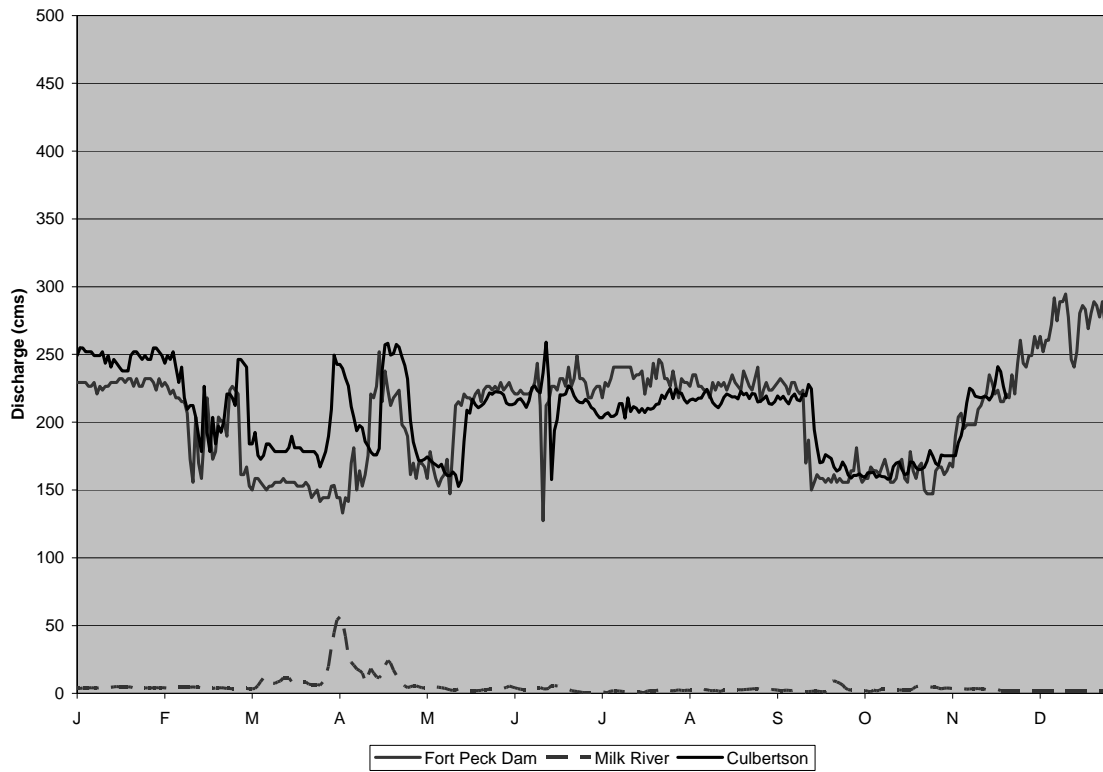


**Plate 11. 2004 Missouri & Milk River discharge downstream of Fort Peck Reservoir.**



**Plate 12. 2005 Missouri & Milk River discharge downstream of Fort Peck Reservoir.**





**Plate 13. 2006 Missouri & Milk River discharge downstream of Fort Peck Reservoir.**

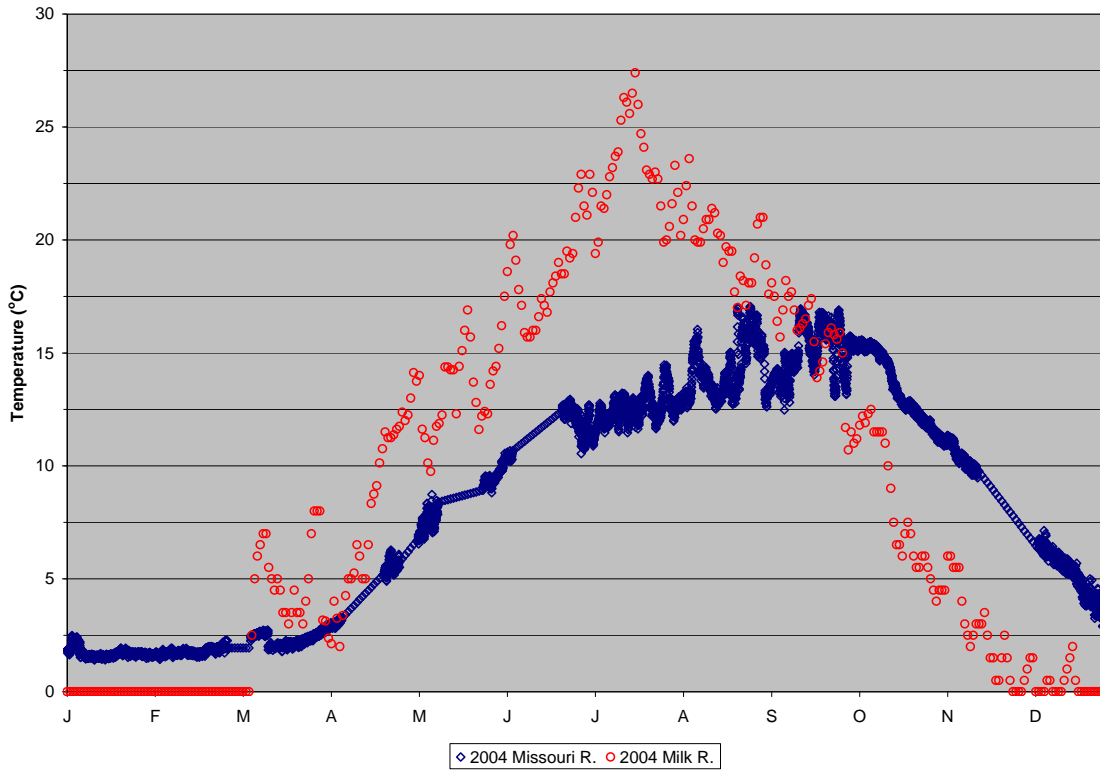


Plate 14. 2004 Fort Peck Dam & Milk River discharge temperatures.

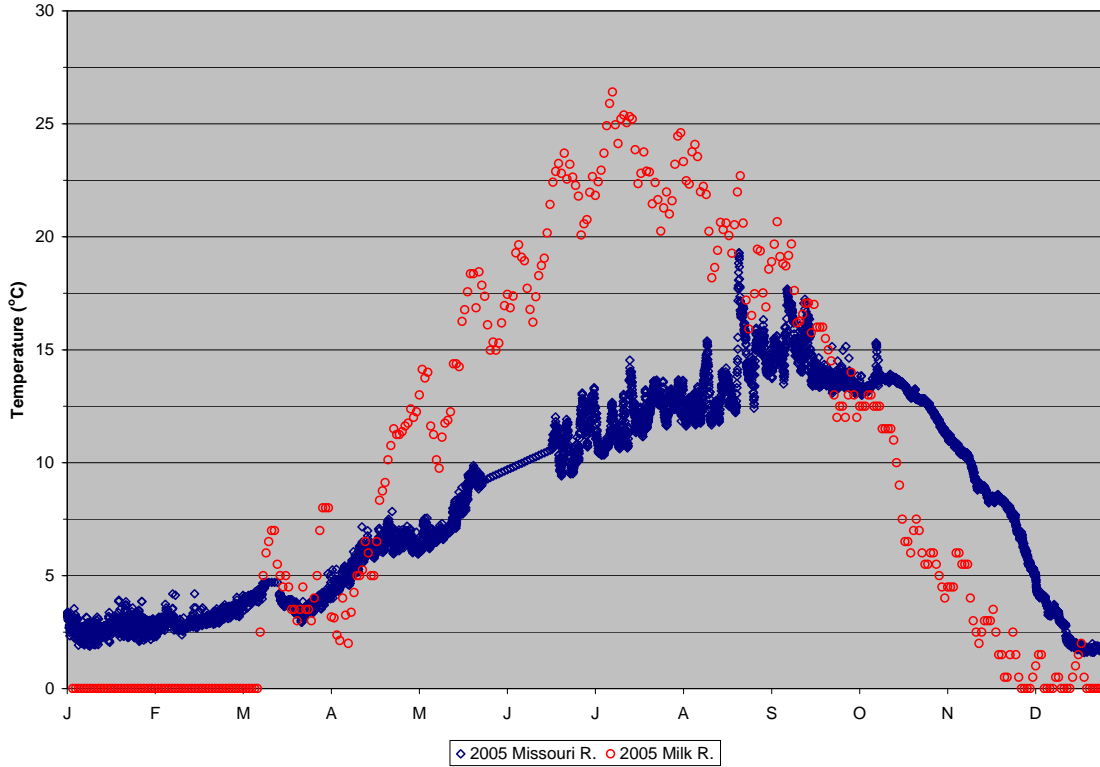
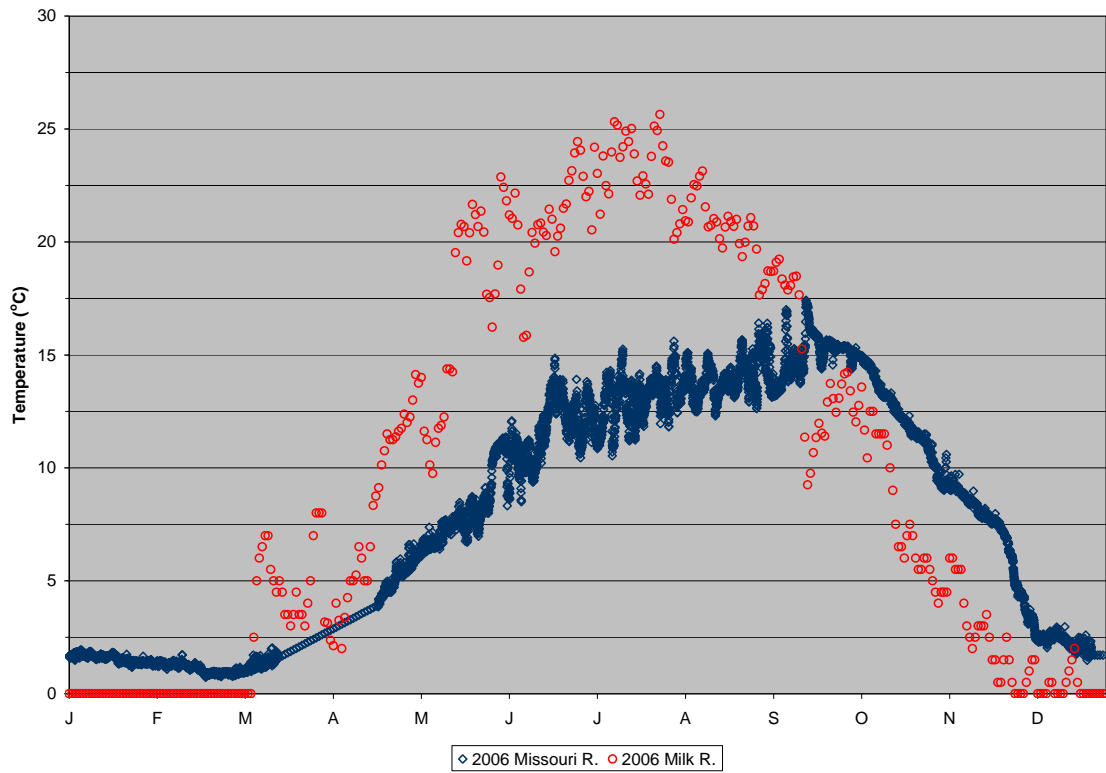
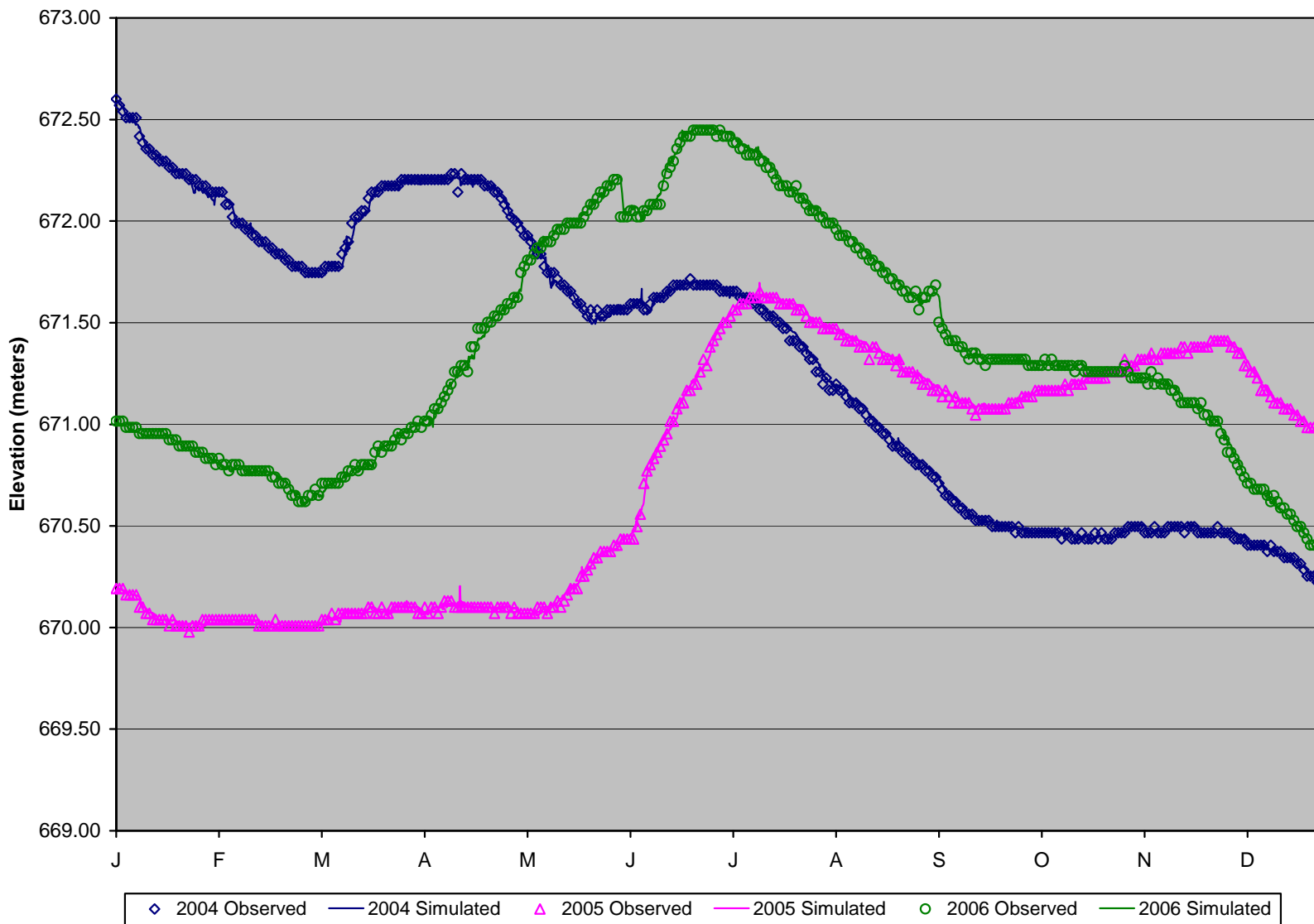


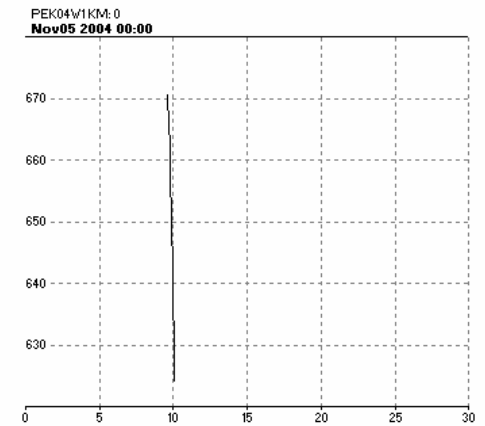
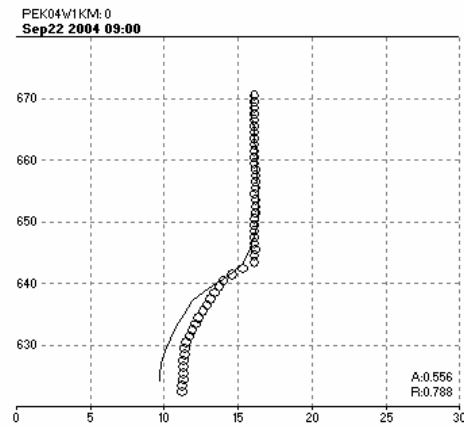
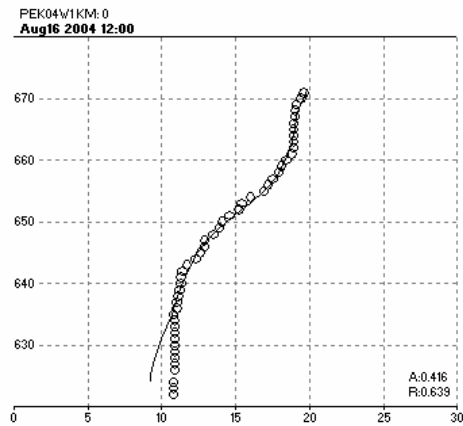
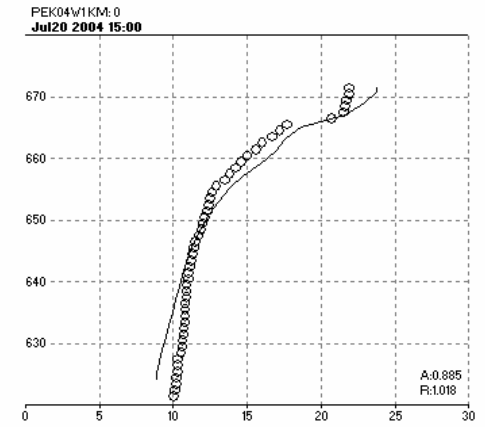
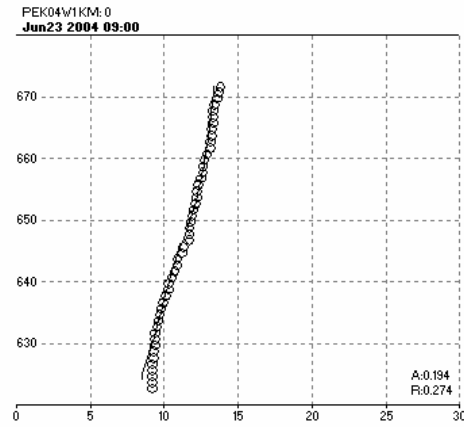
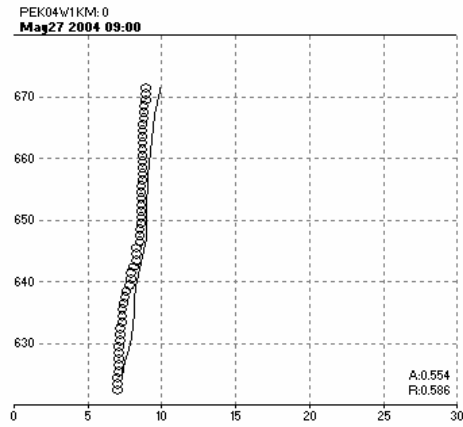
Plate 15. 2005 Fort Peck Dam & Milk River discharge temperatures.



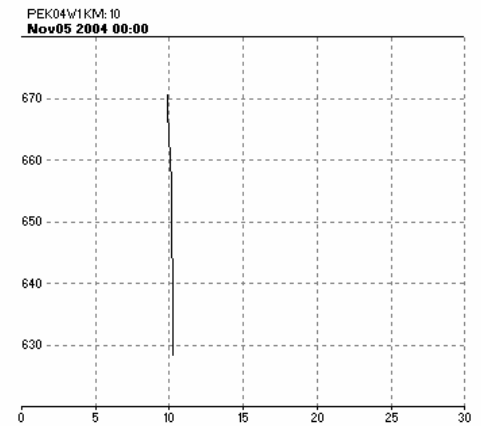
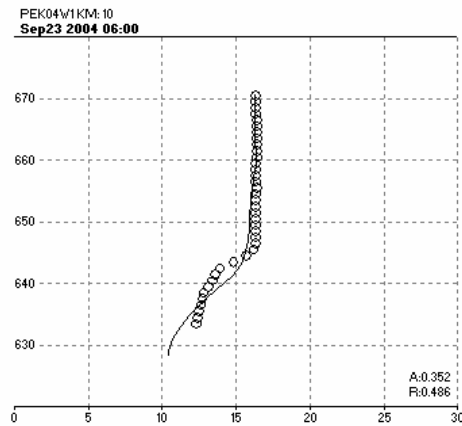
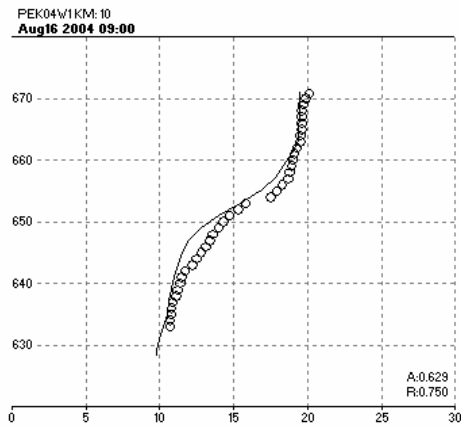
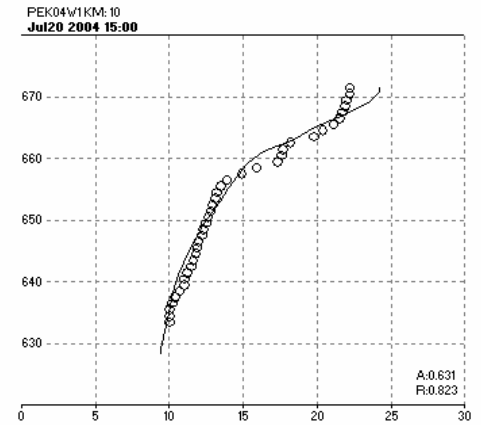
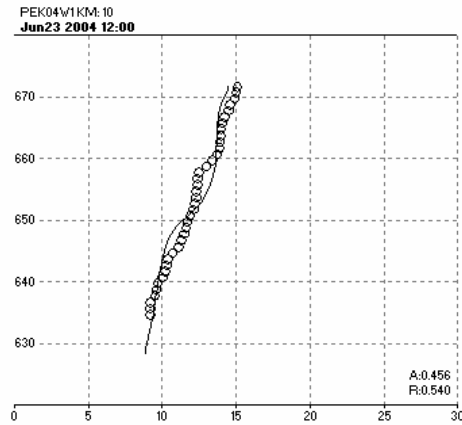
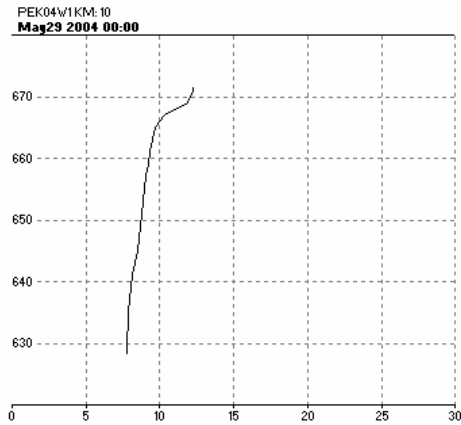
**Plate 16. 2006 Fort Peck Dam & Milk River discharge temperatures.**



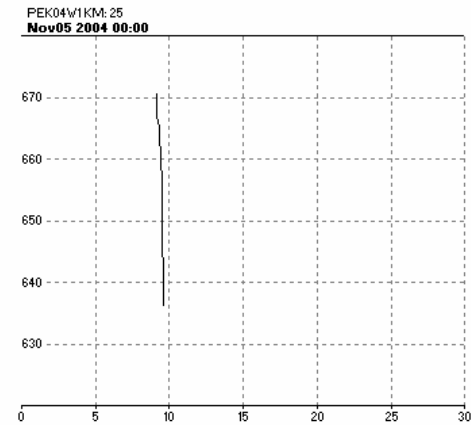
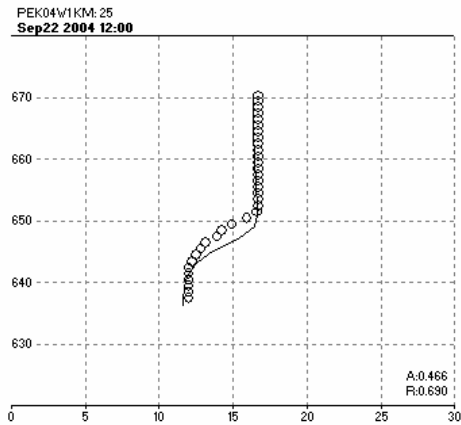
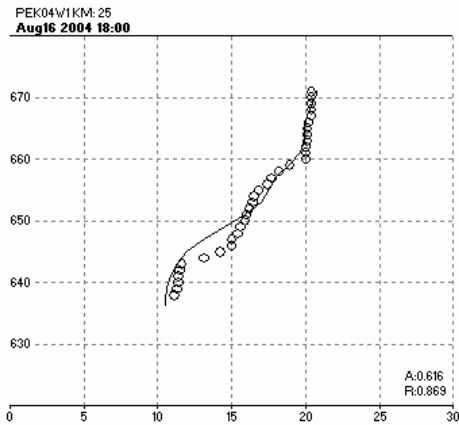
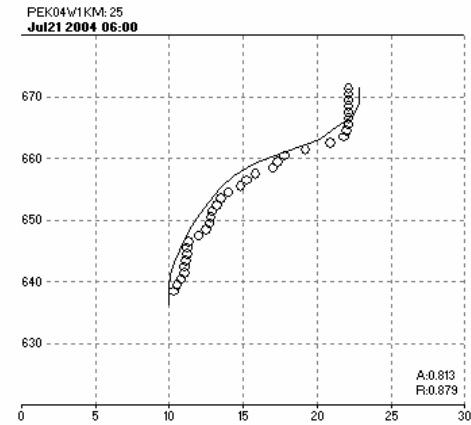
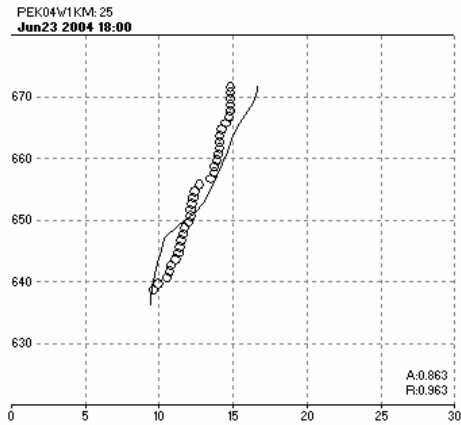
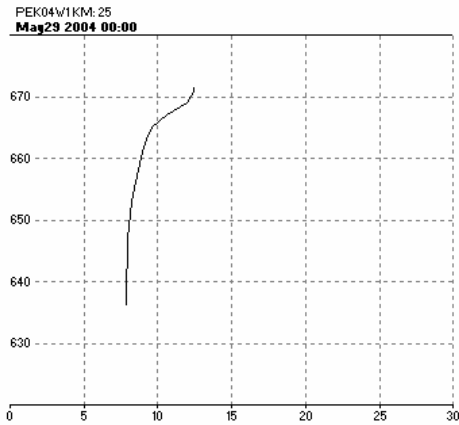
**Plate 17. Fort Peck Lake observed and simulated lake elevations from 2004 to 2006.**



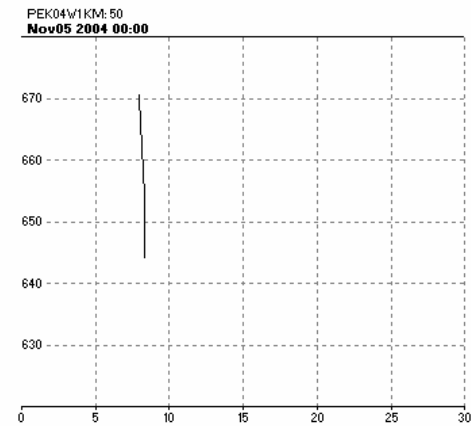
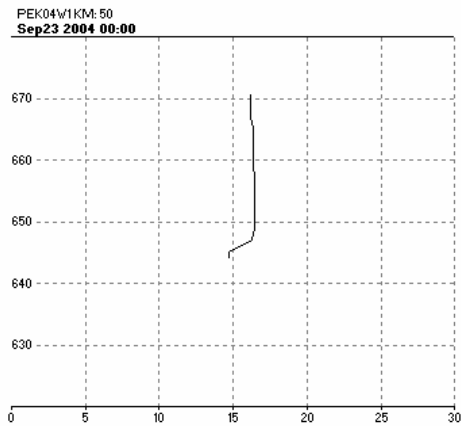
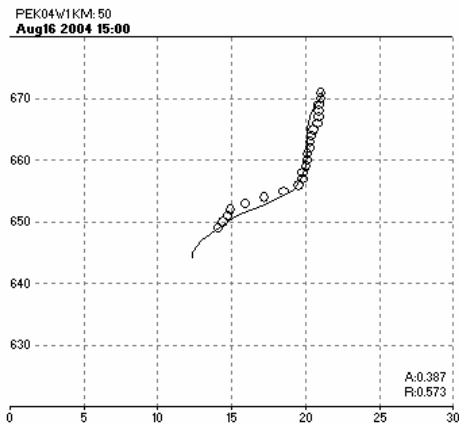
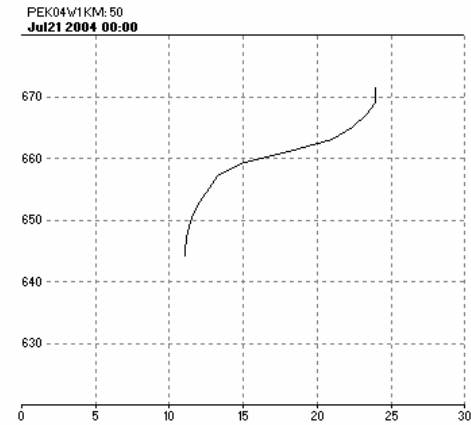
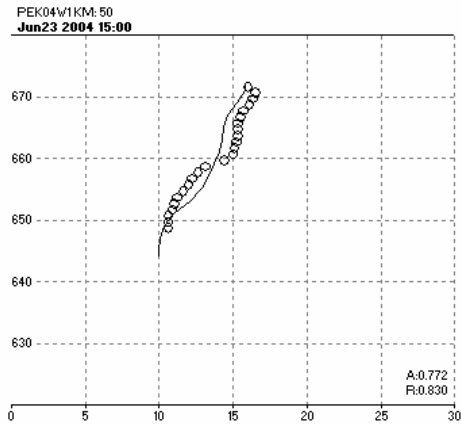
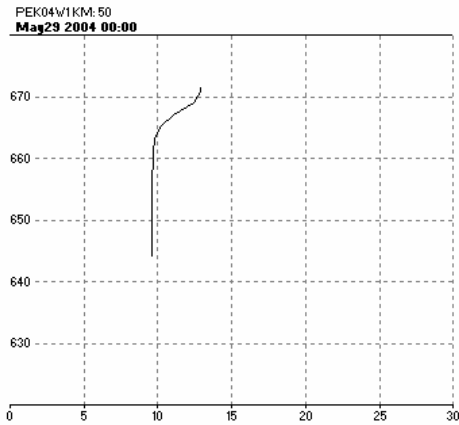
**Plate 18. 2004 measured and simulated water temperature profiles at L1 (0 km from the dam) in the Missouri River arm.**



**Plate 19. 2004 measured and simulated water temperature profiles at L2 (10 km from the dam) in the Missouri River arm.**

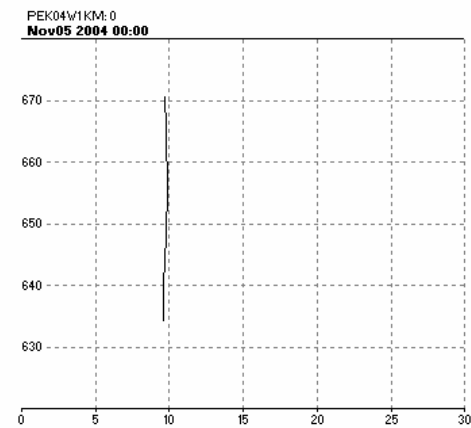
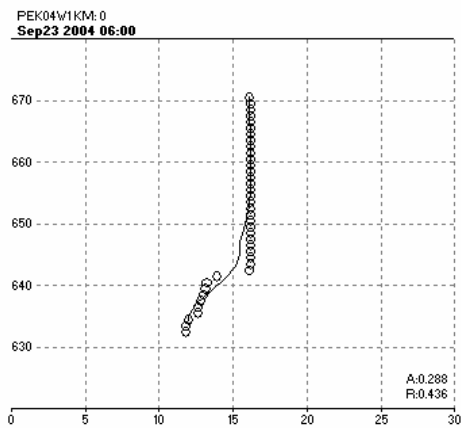
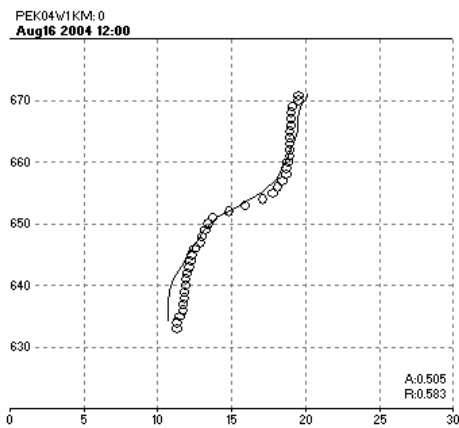
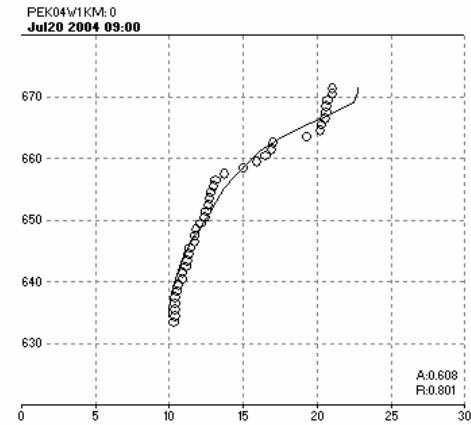
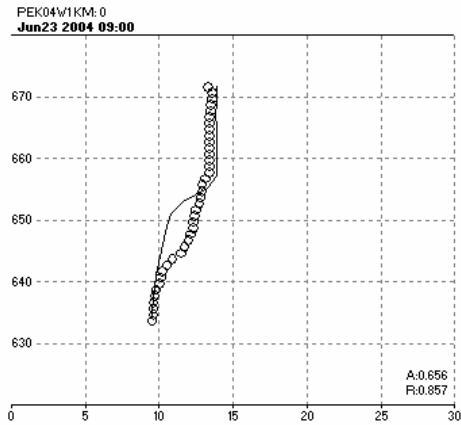
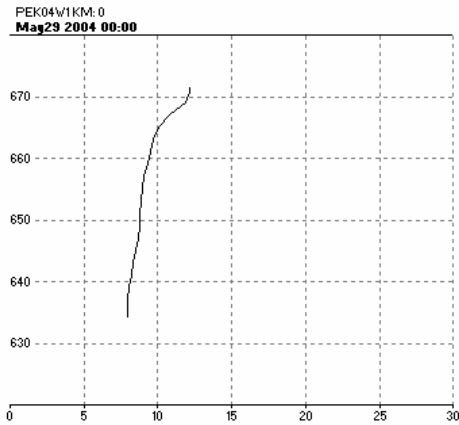


**Plate 20. 2004 measured and simulated water temperature profiles at L3 (25 km from the dam) in the Missouri River arm.**

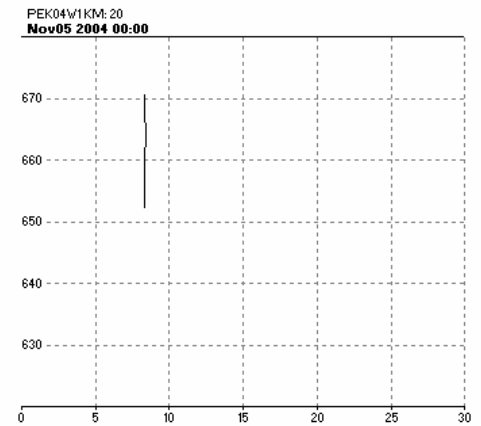
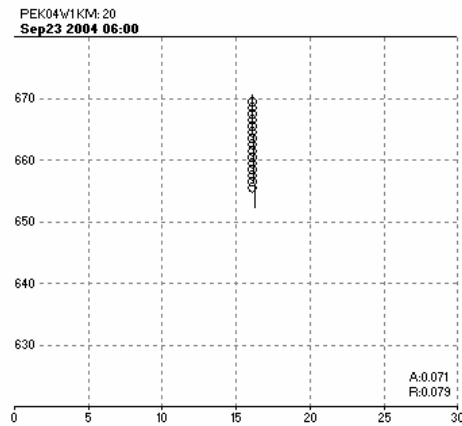
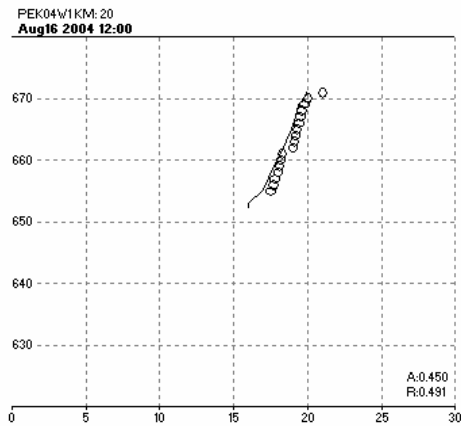
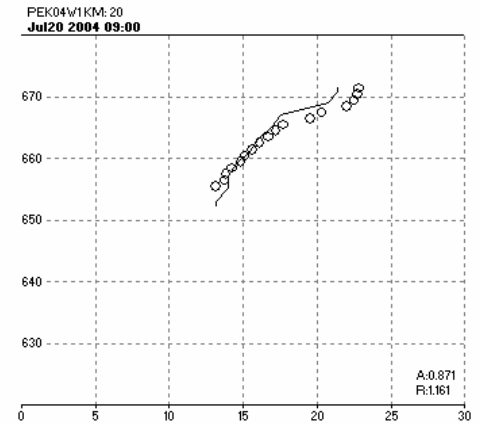
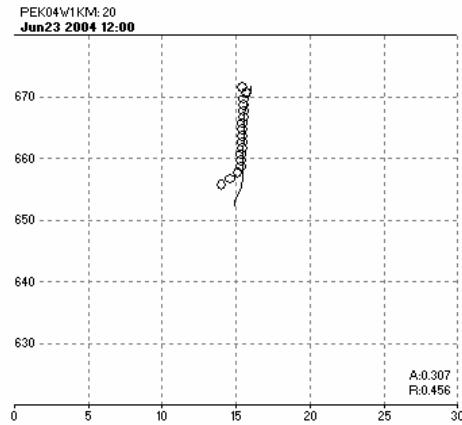
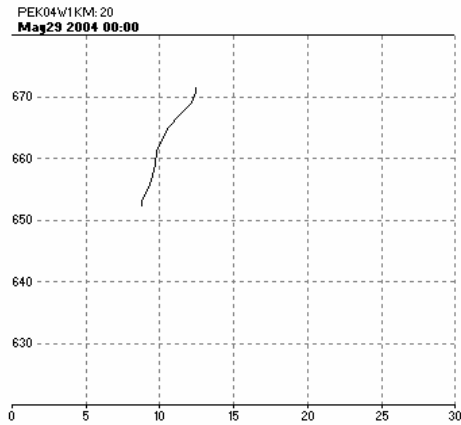


**Plate 21. 2004 measured and simulated water temperature profiles at L4 (50 km from the dam) in the Missouri River arm.**

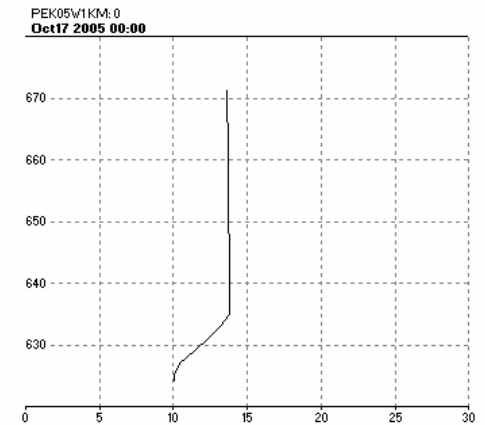
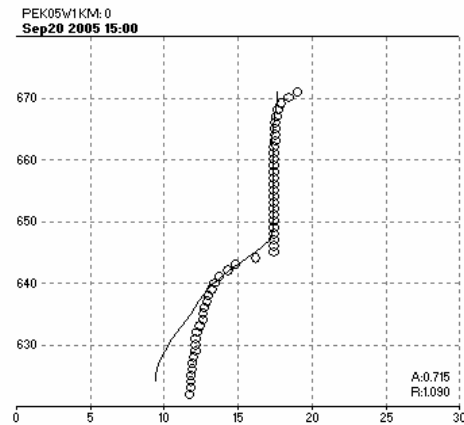
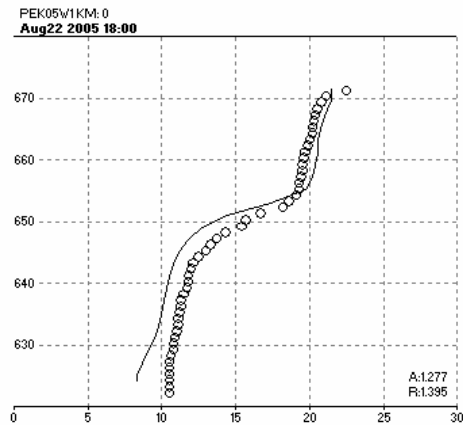
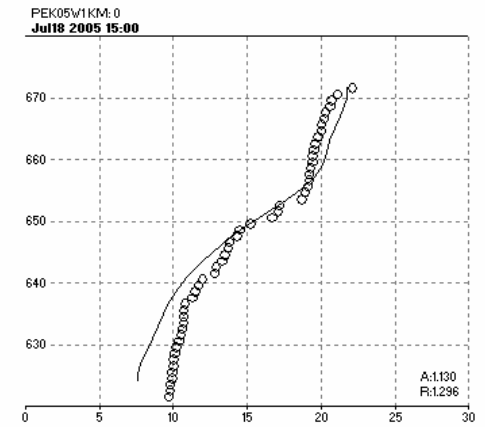
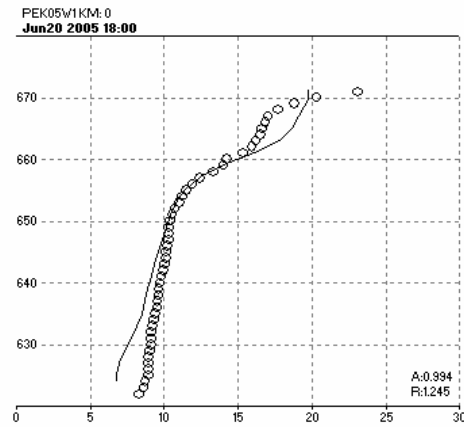
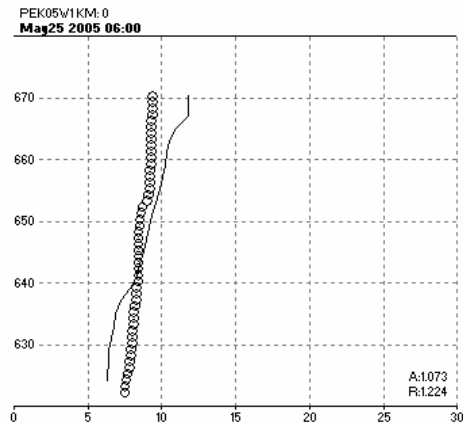




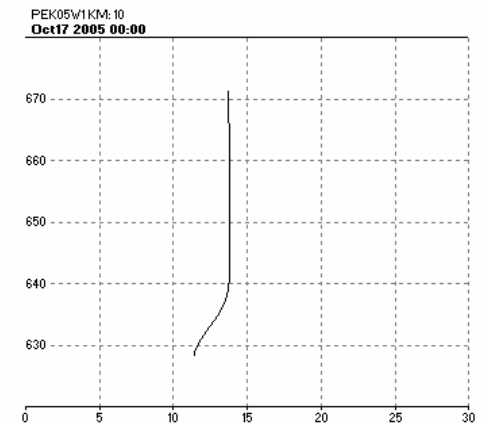
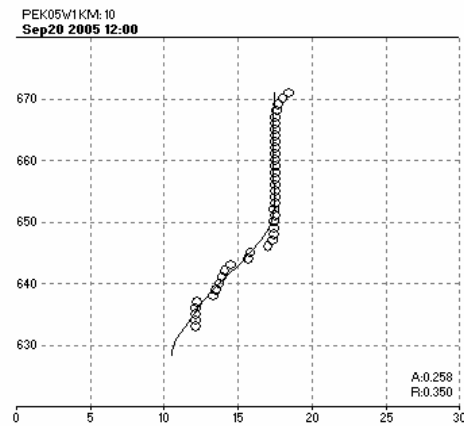
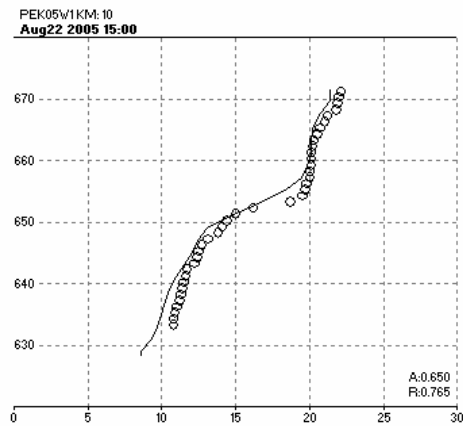
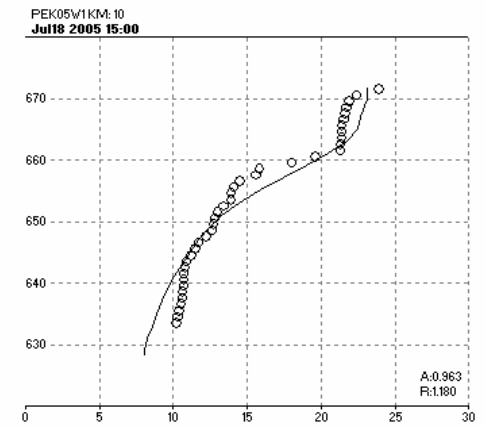
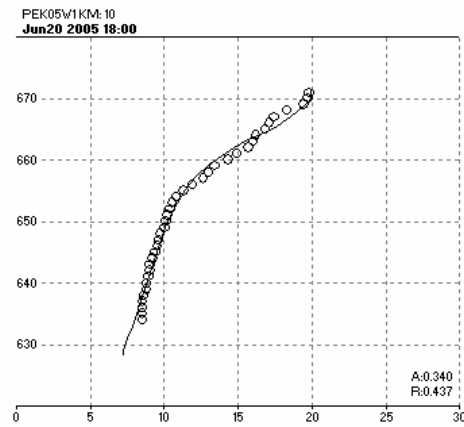
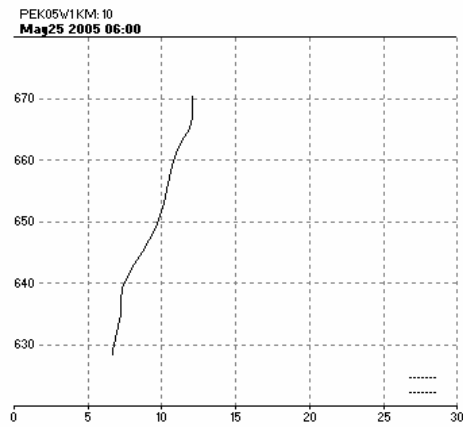
**Plate 22. 2004 measured and simulated water temperature profiles at L5 in the Big Dry arm.**



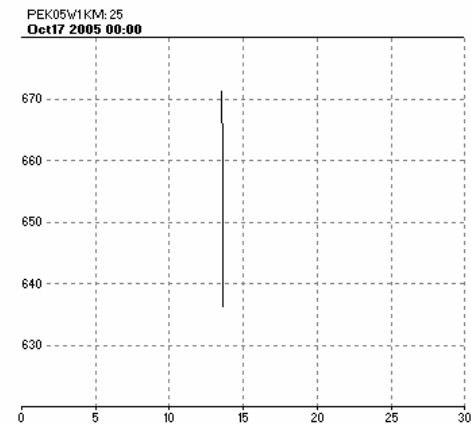
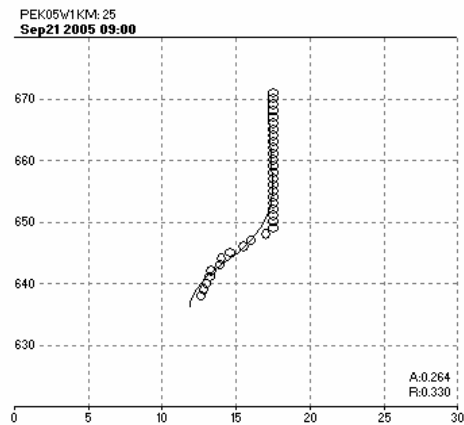
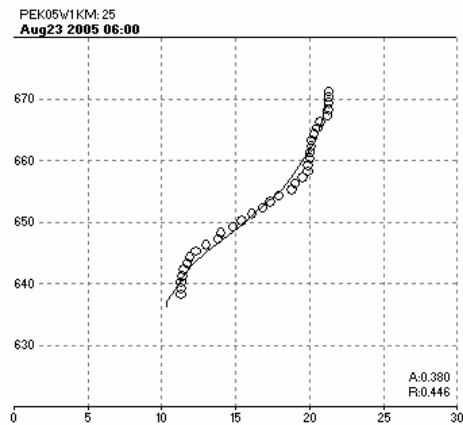
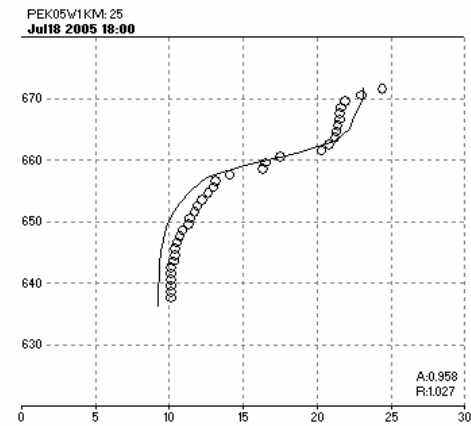
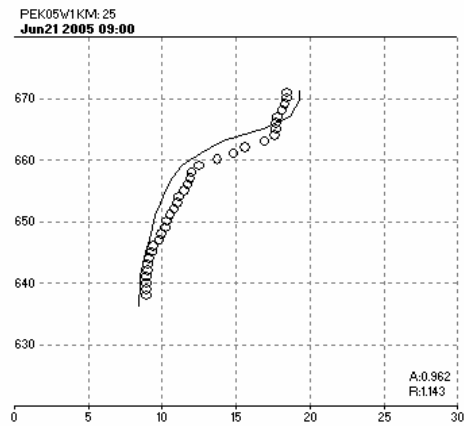
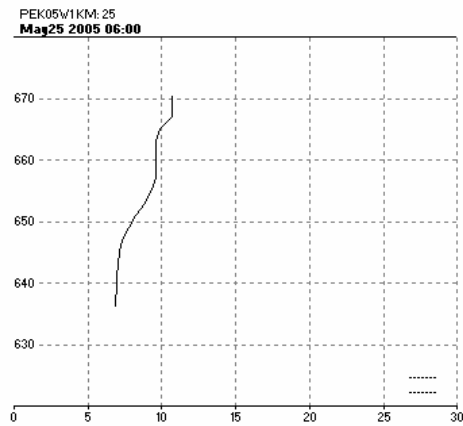
**Plate 23. 2004 measured and simulated water temperature profiles at L6 in the Big Dry arm.**



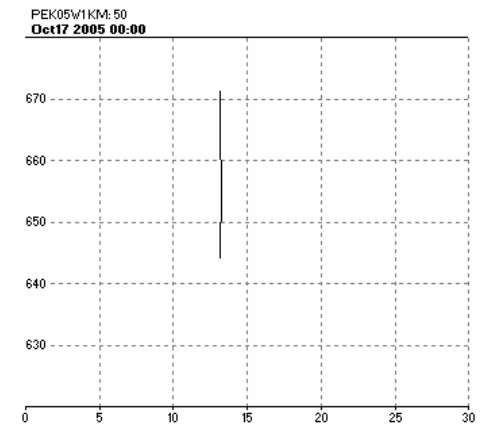
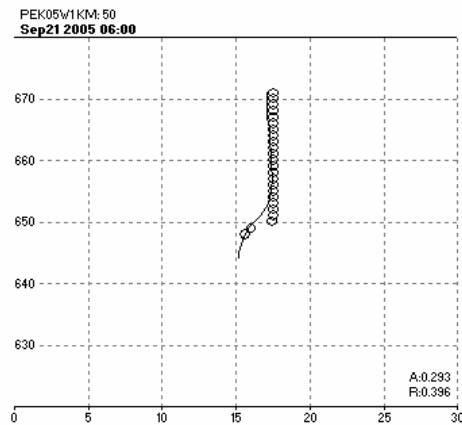
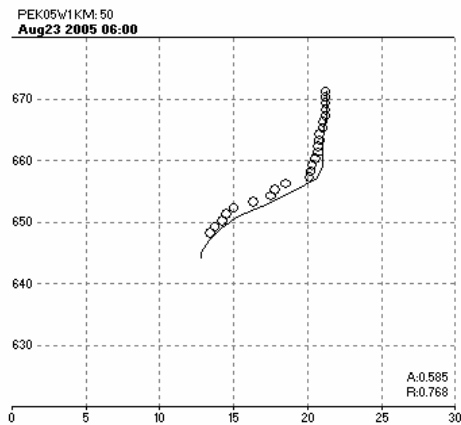
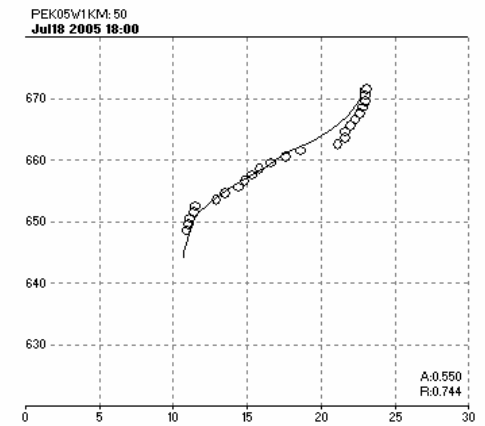
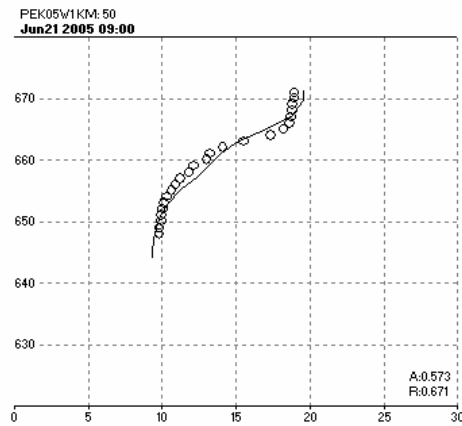
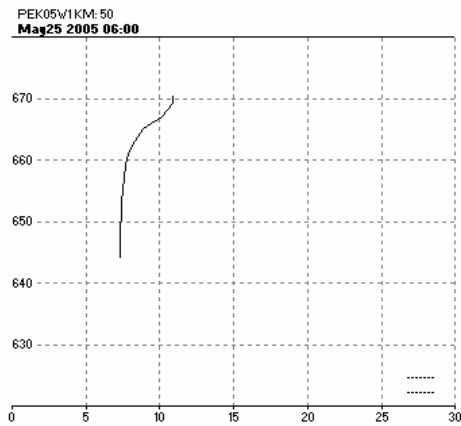
**Plate 24. 2005 measured and simulated water temperature profiles at L1 (0 km from the dam) in the Missouri River arm.**



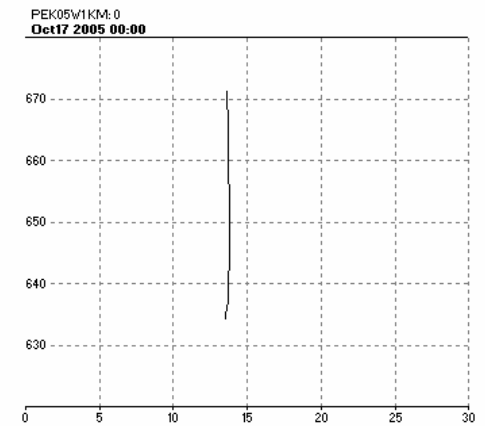
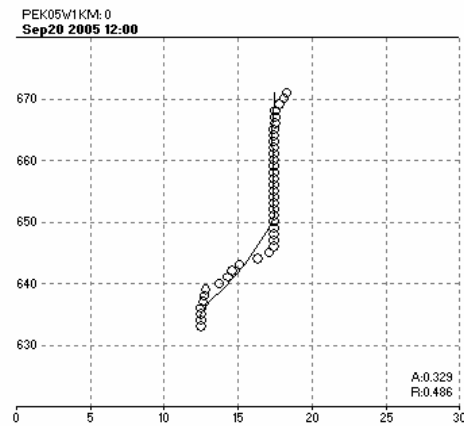
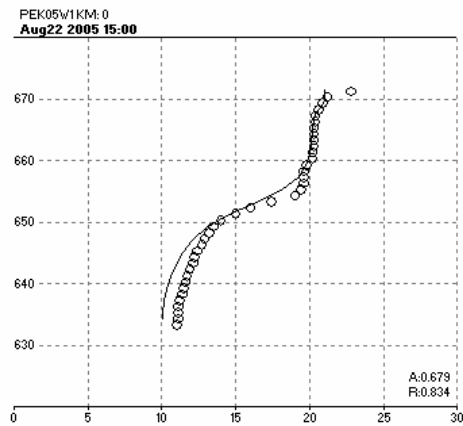
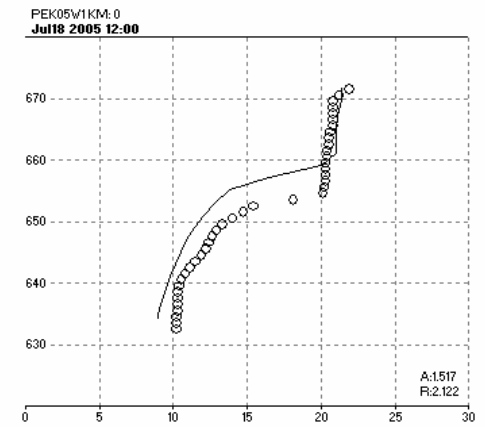
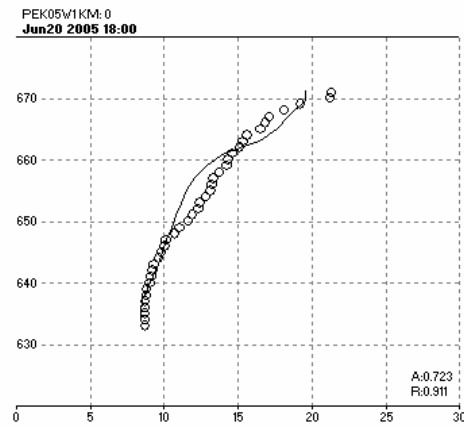
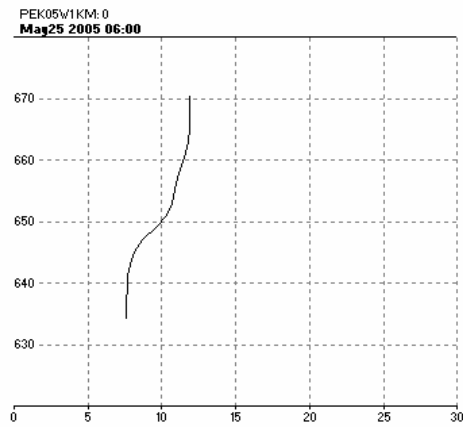
**Plate 25. 2005 measured and simulated water temperature profiles at L2 (10 km from the dam) in the Missouri River arm.**



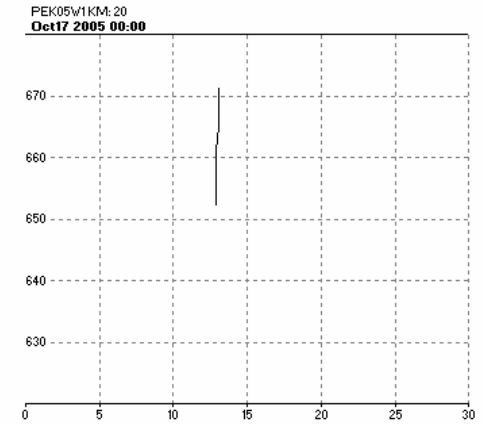
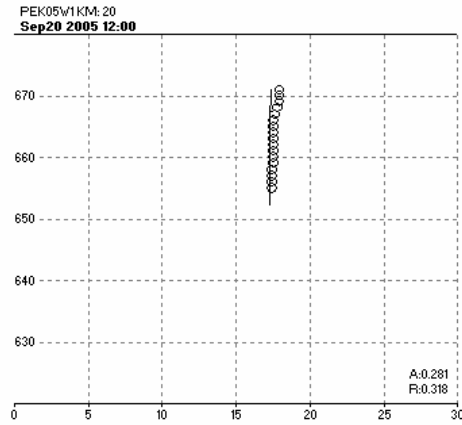
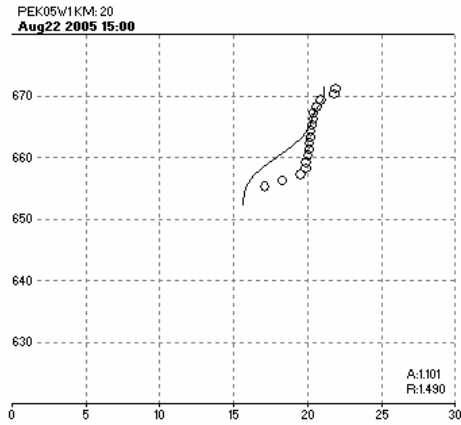
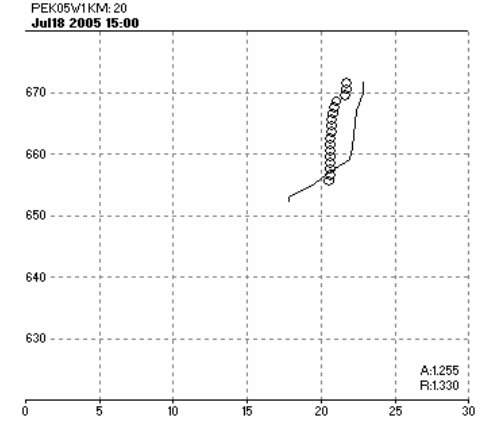
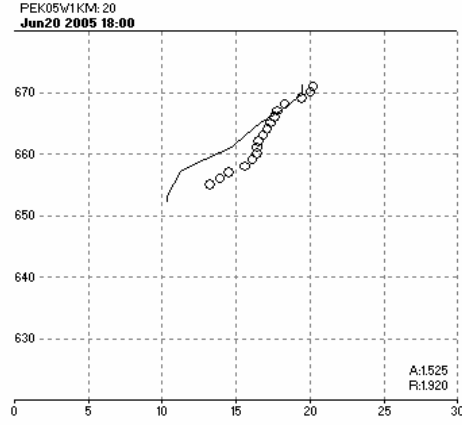
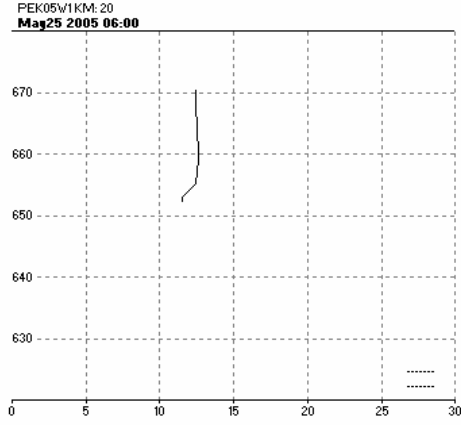
**Plate 26. 2005 measured and simulated water temperature profiles at L3 (25 km from the dam) in the Missouri River arm.**



**Plate 27. 2005 measured and simulated water temperature profiles at L4 (50 km from the dam) in the Missouri River arm.**

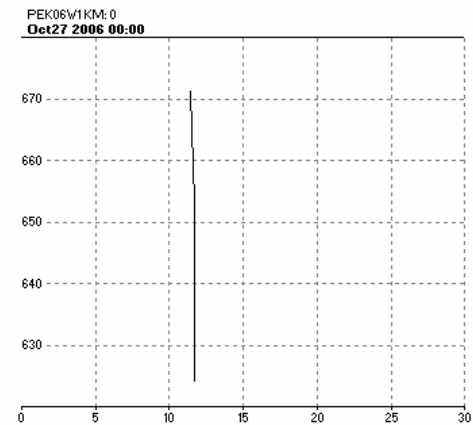
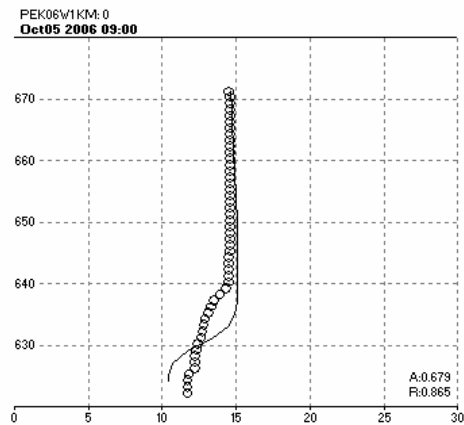
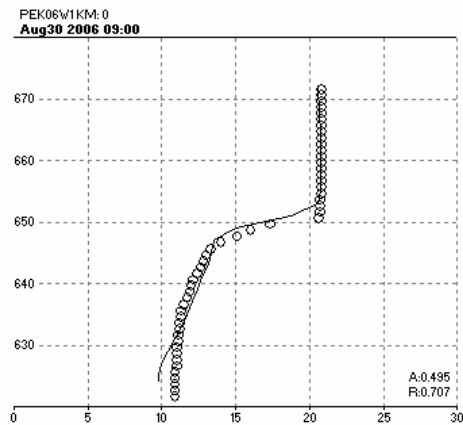
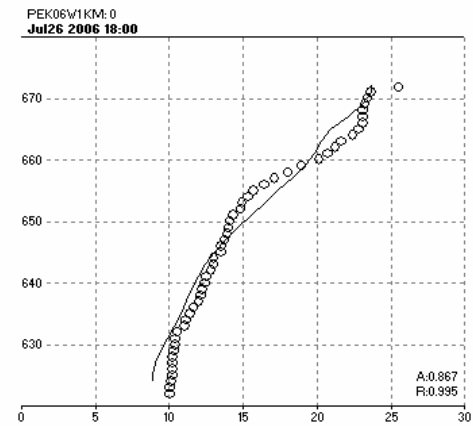
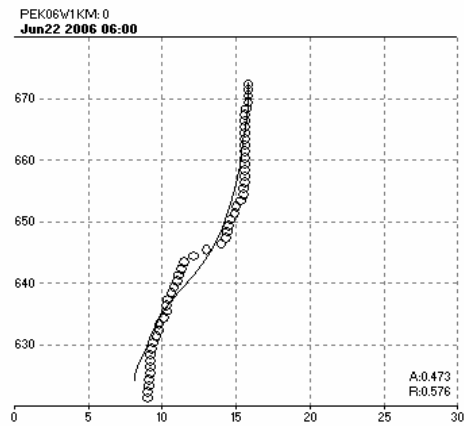
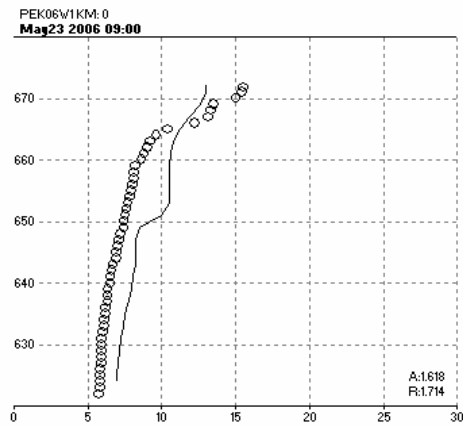


**Plate 28. 2005 measured and simulated water temperature profiles at L5 in the Big Dry arm.**

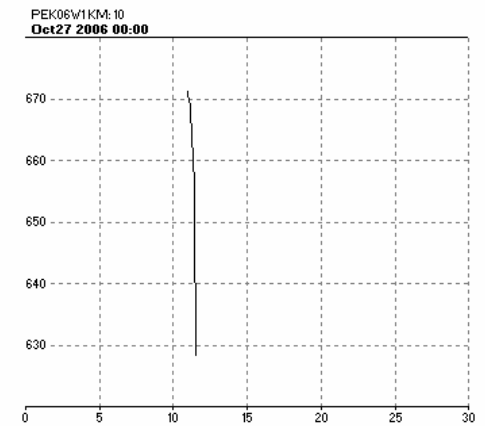
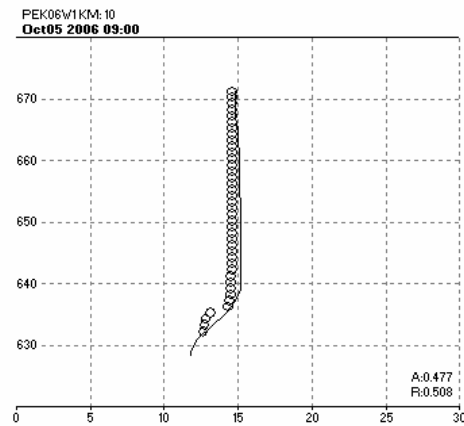
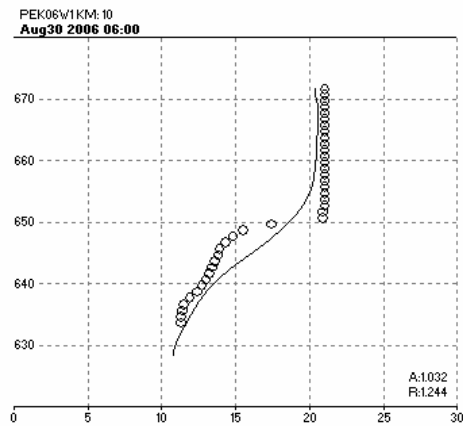
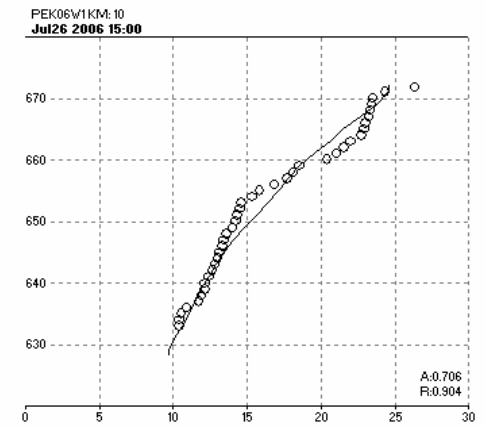
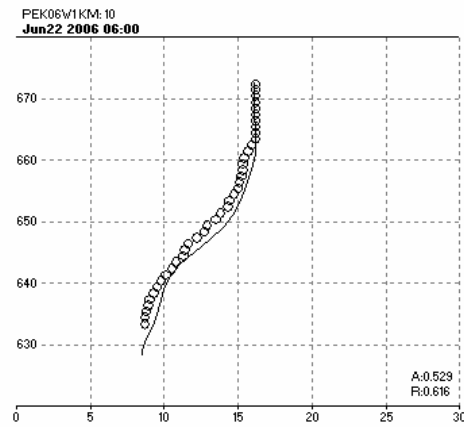
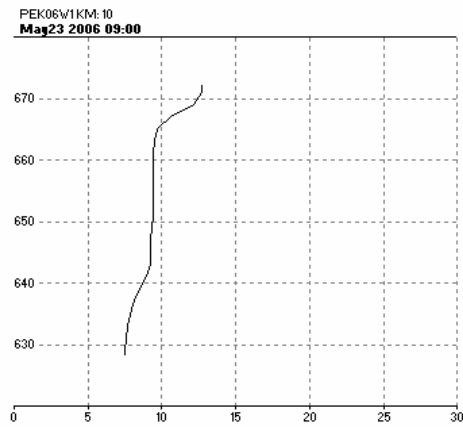


**Plate 29. 2005 measured and simulated water temperature profiles at L6 in the Big Dry arm.**

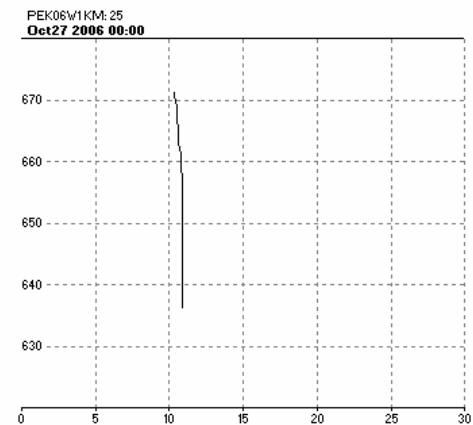
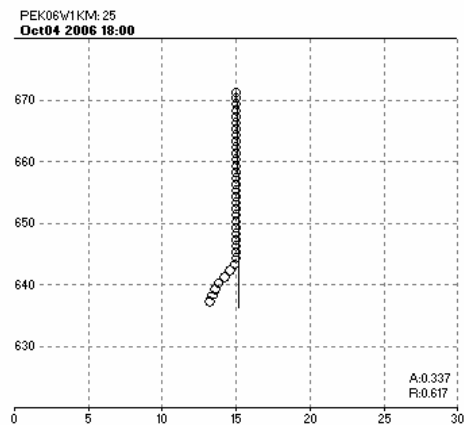
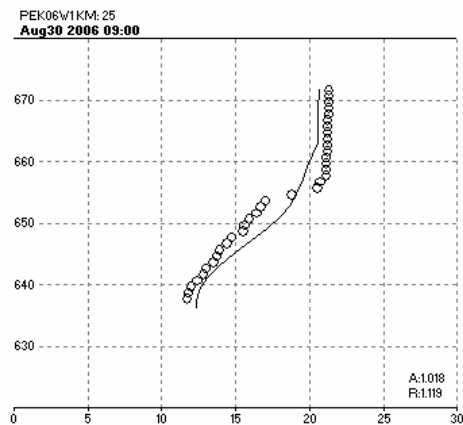
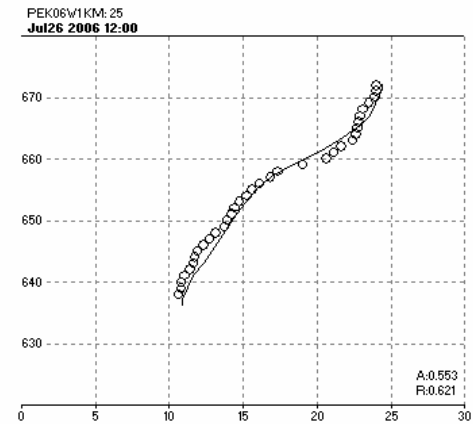
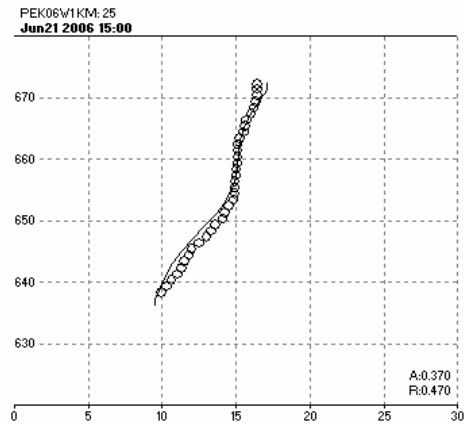
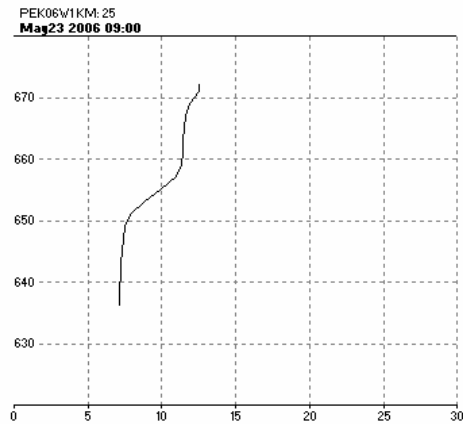




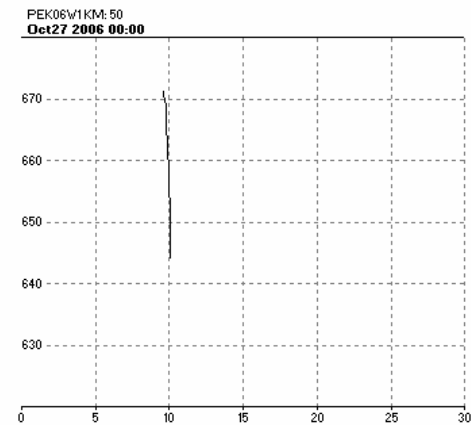
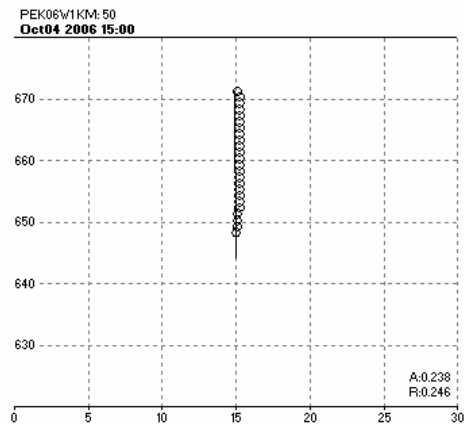
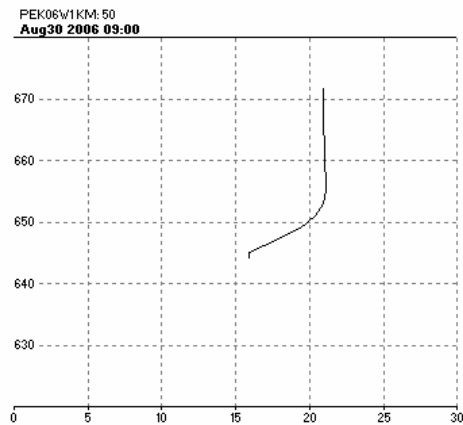
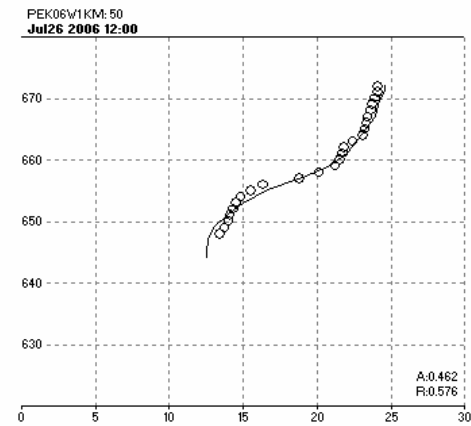
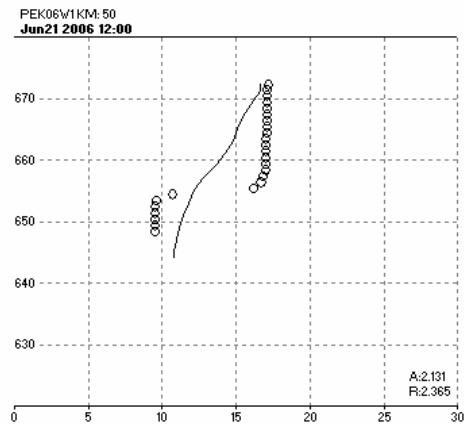
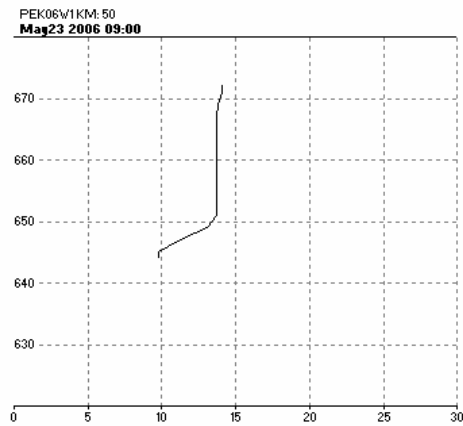
**Plate 30. 2006 measured and simulated water temperature profiles at L1 (0 km from the dam) in the Missouri River arm.**



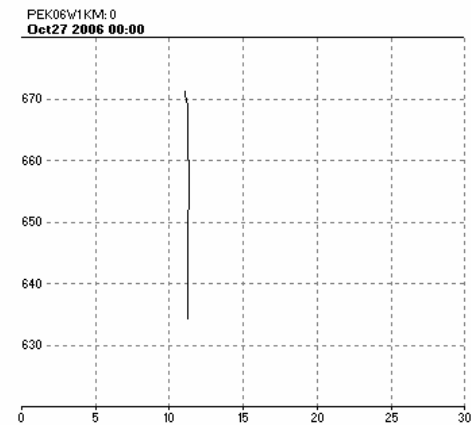
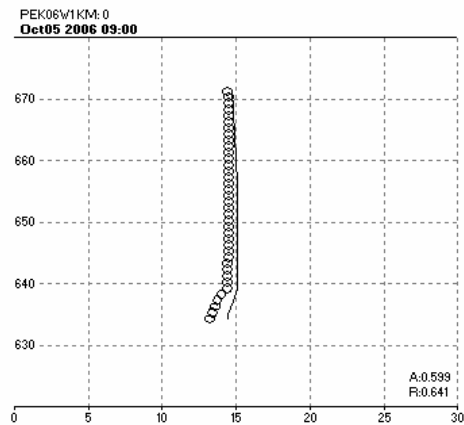
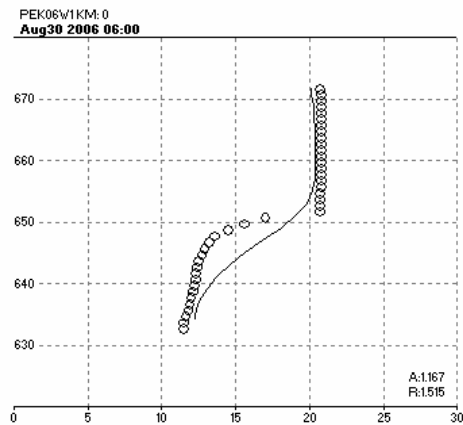
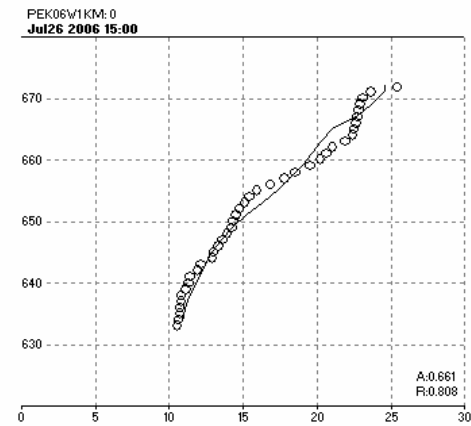
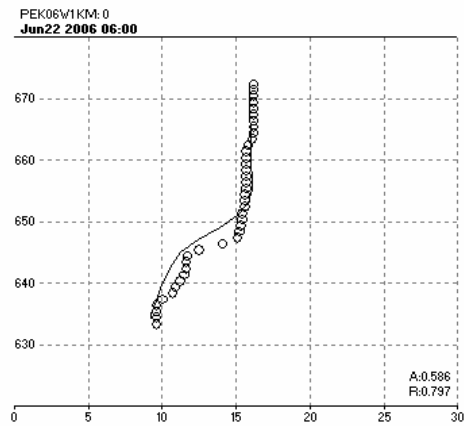
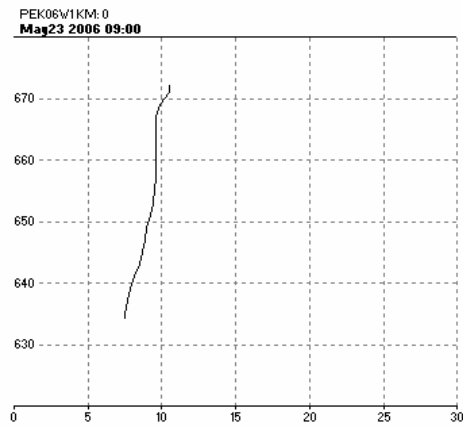
**Plate 31. 2006 measured and simulated water temperature profiles at L2 (10 km from the dam) in the Missouri River arm.**



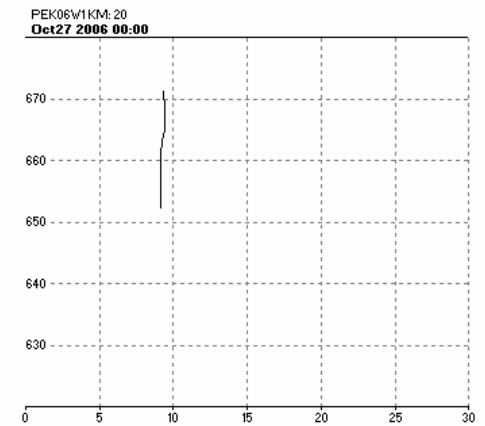
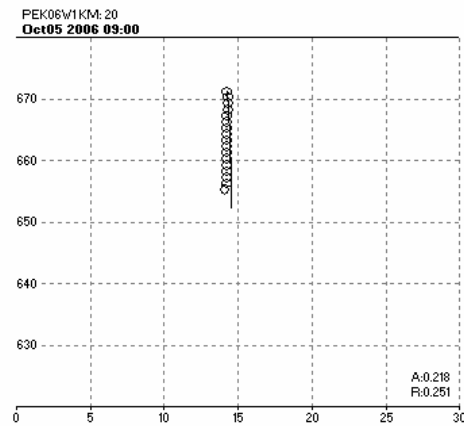
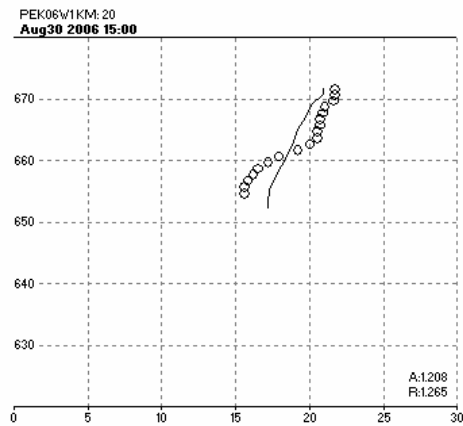
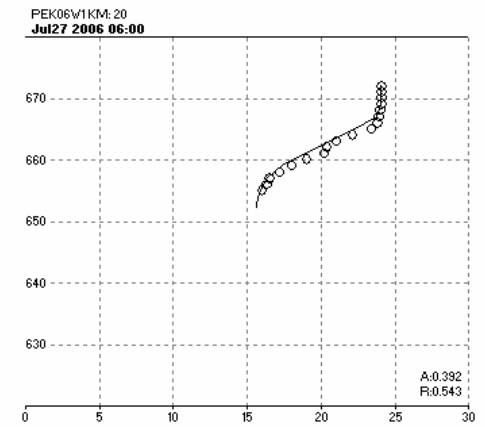
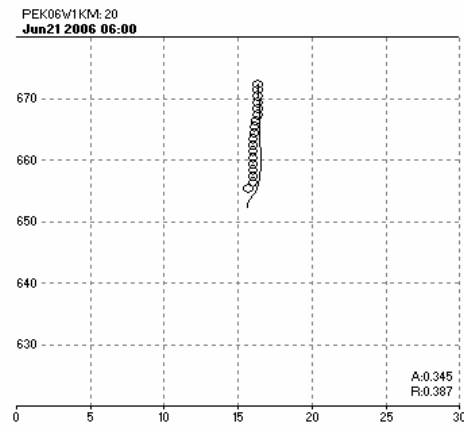
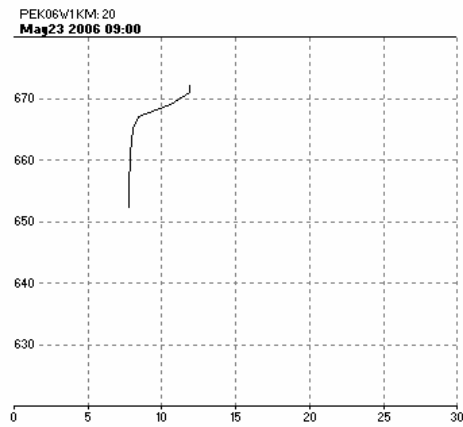
**Plate 32. 2006 measured and simulated water temperature profiles at L3 (25 km from the dam) in the Missouri River arm.**



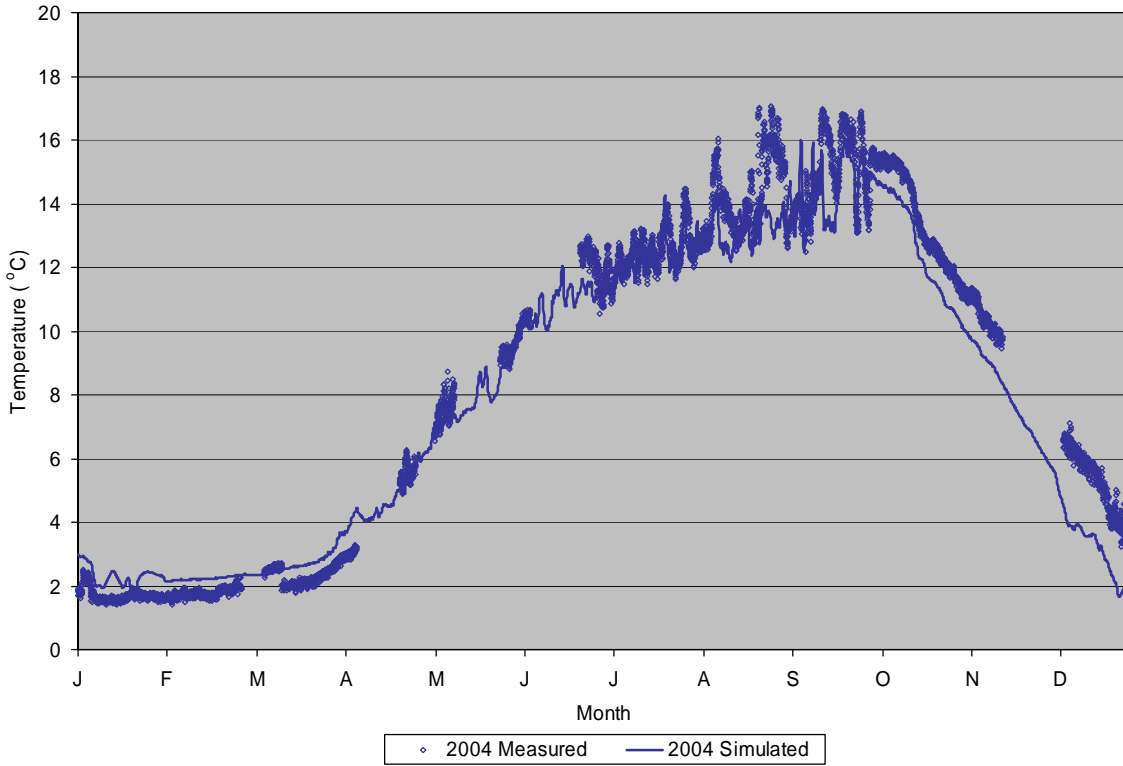
**Plate 33. 2006 measured and simulated water temperature profiles at L4 (50 km from the dam) in the Missouri River arm.**



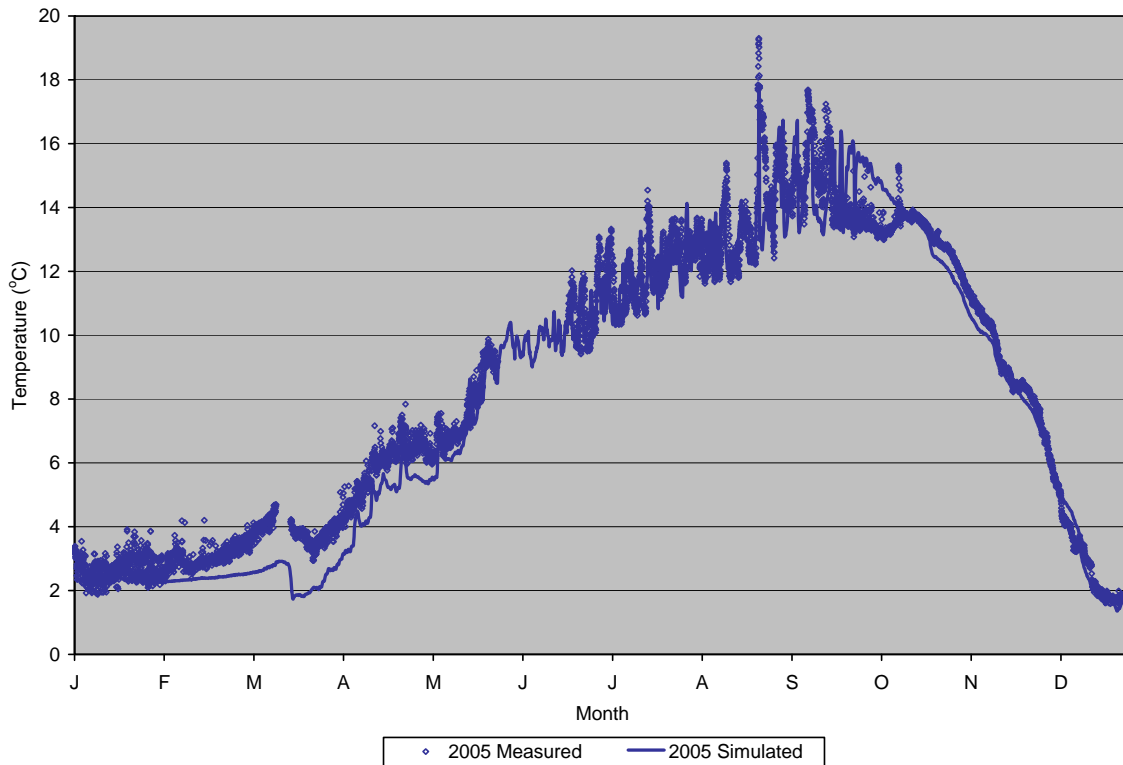
**Plate 34. 2006 measured and simulated water temperature profiles at L5 in the Big Dry arm.**



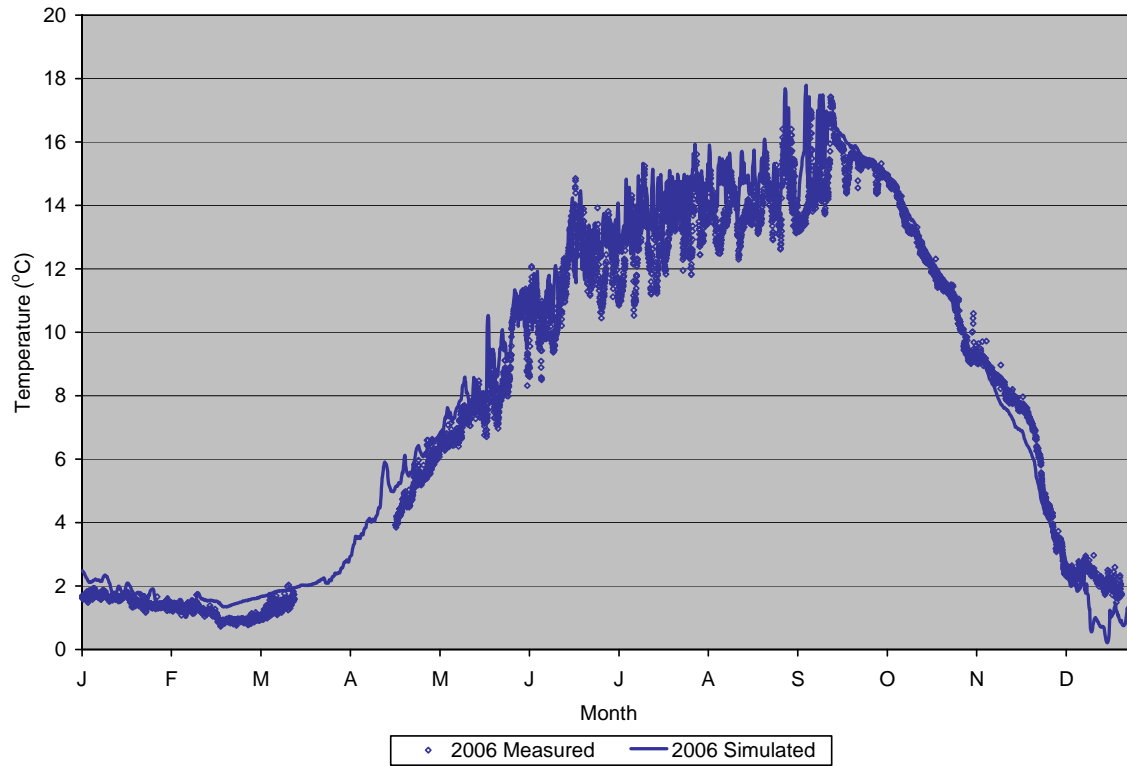
**Plate 35. 2006 measured and simulated water temperature profiles at L6 in the Big Dry arm.**



**Plate 36. 2004 observed and simulated Fort Peck dam release temperatures.**

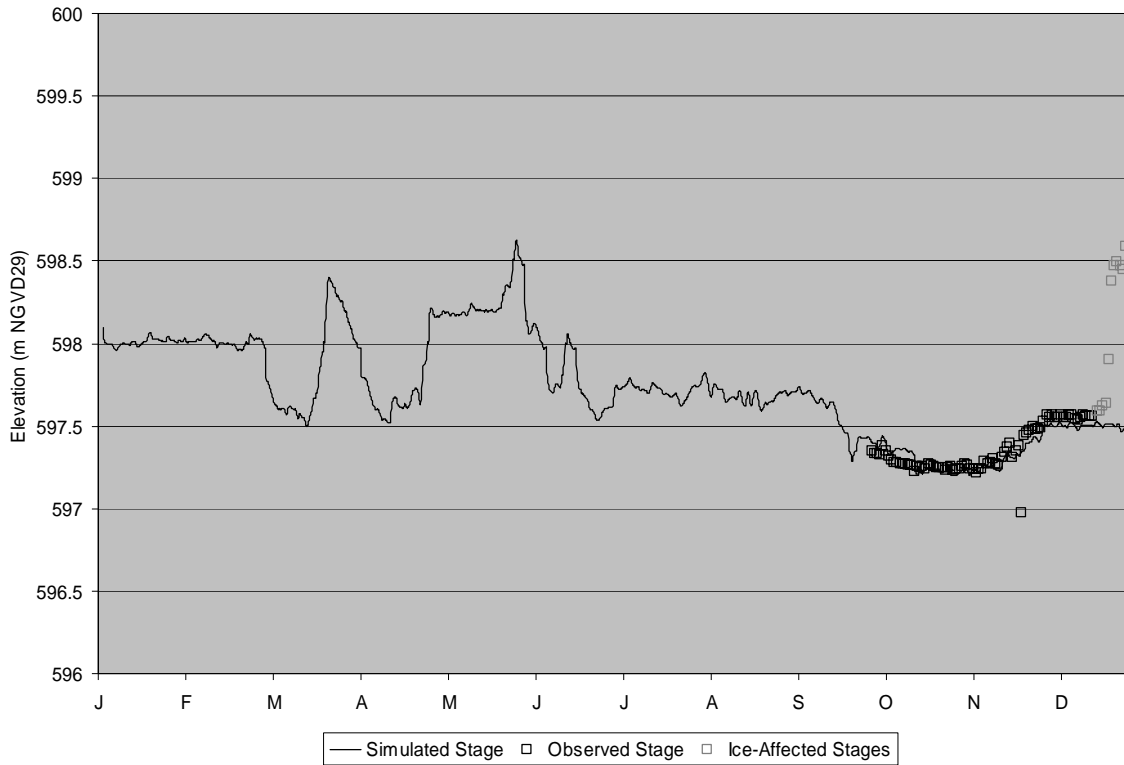


**Plate 37. 2005 observed and simulated Fort Peck dam release temperatures.**

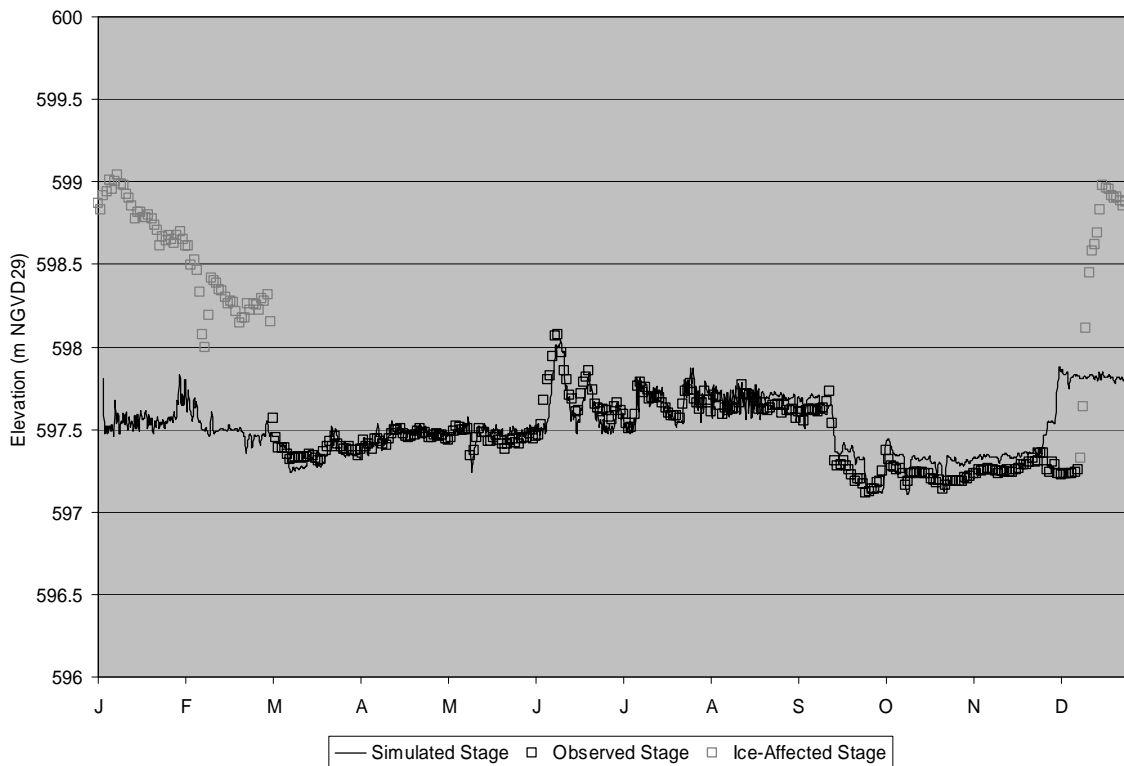


**Plate 38. 2006 observed and simulated Fort Peck dam release temperatures.**

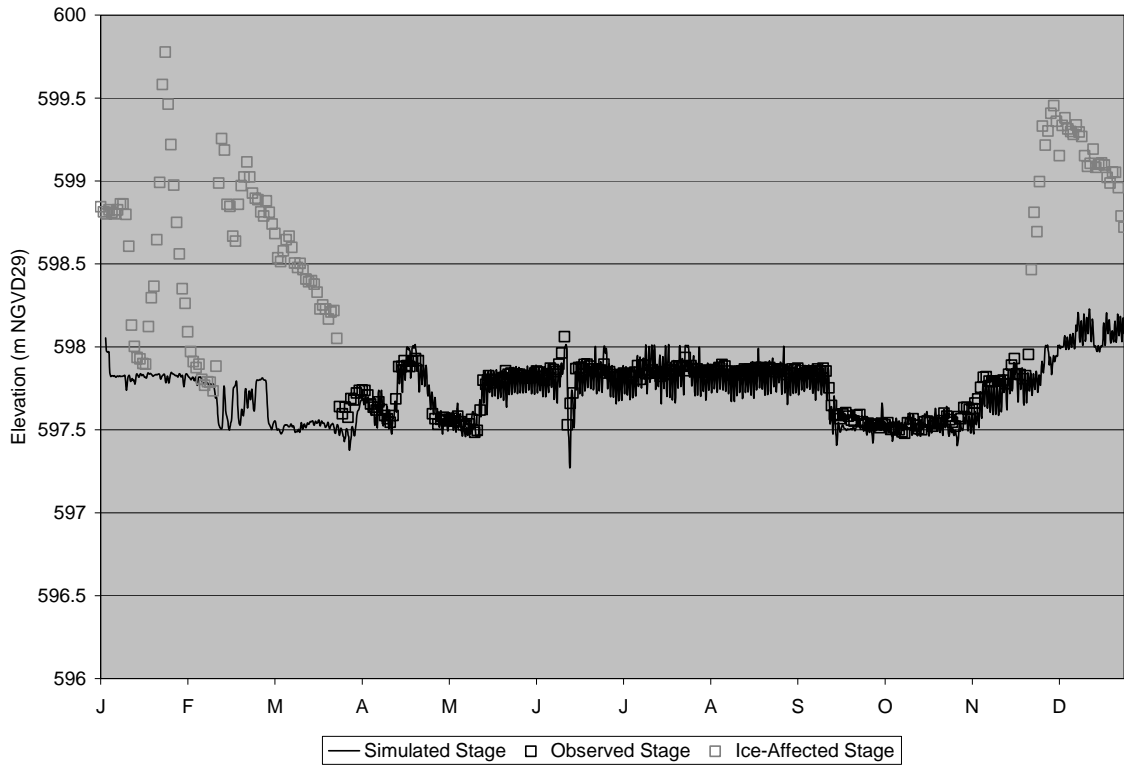




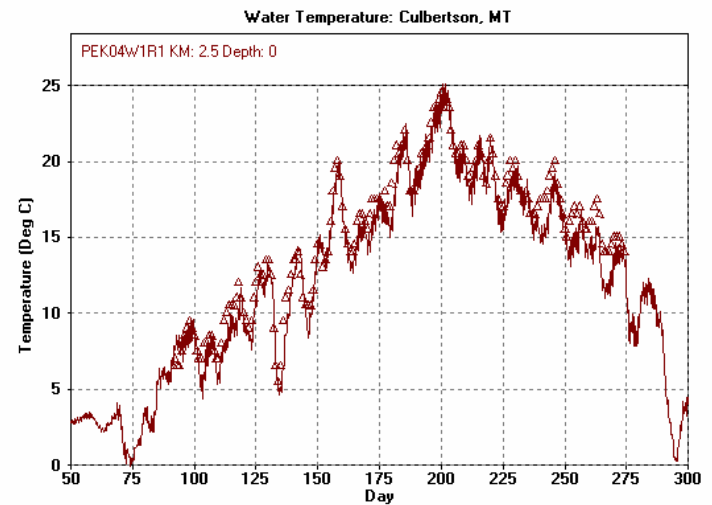
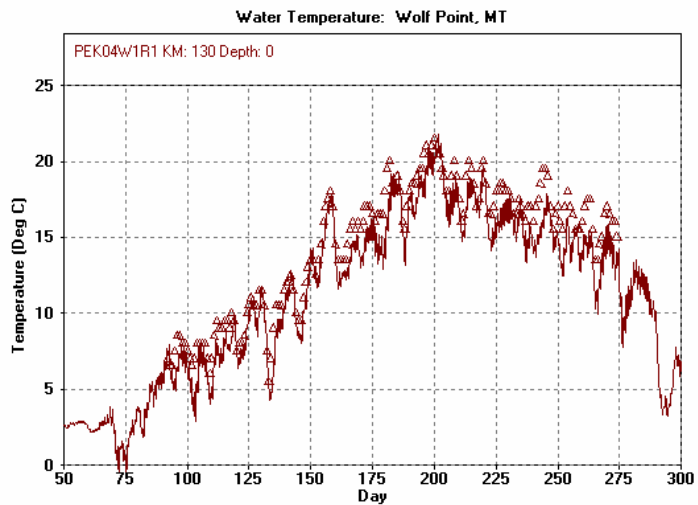
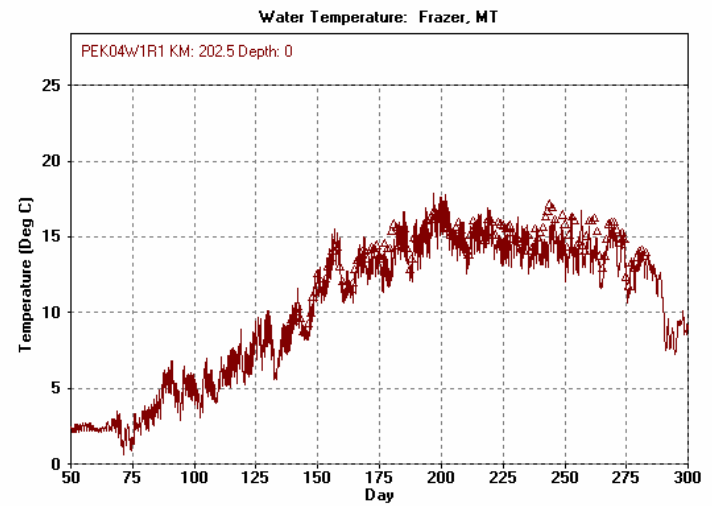
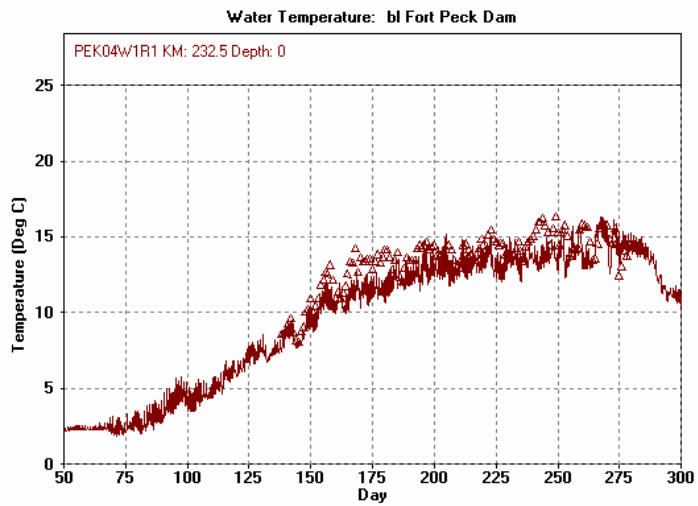
**Plate 39. 2004 Missouri River calibrated river stage at Wolf Point, MT gage (W2 Location 129.5 km).**



**Plate 40. 2005 Missouri River calibrated river stage at Wolf Point, MT gage (W2 Location 129.5 km).**



**Plate 41. 2006 Missouri River calibrated river stage at Wolf Point, MT gage (W2 Location 129.5 km).**



**Plate 42. 2004 Missouri River simulated water temperatures calibrated to measured water temperatures.**

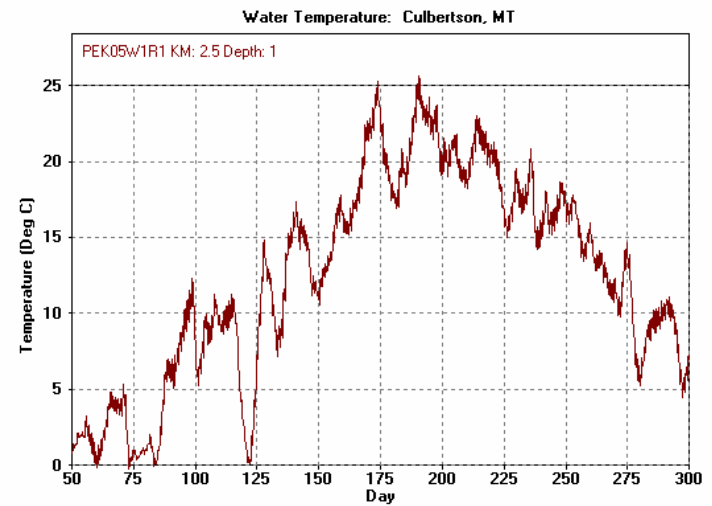
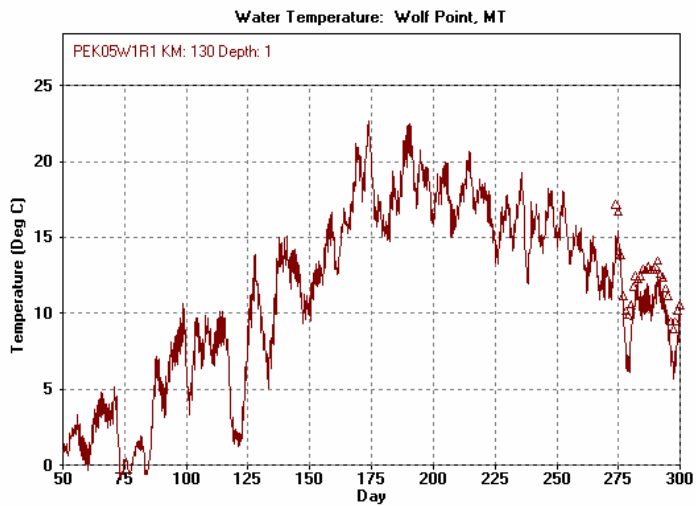
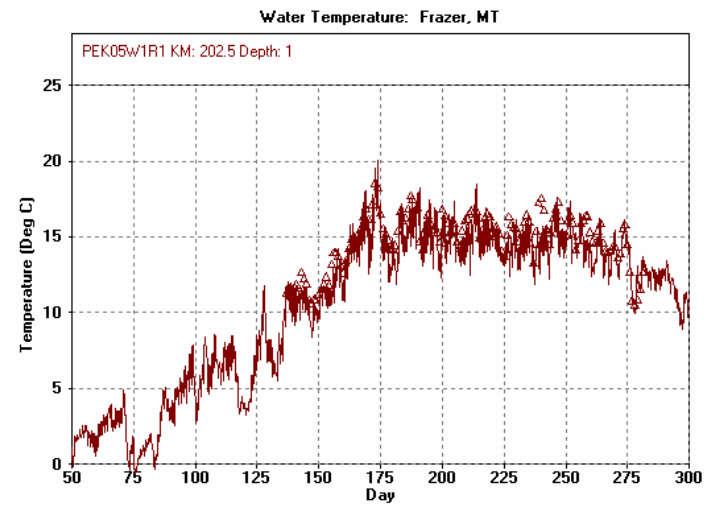
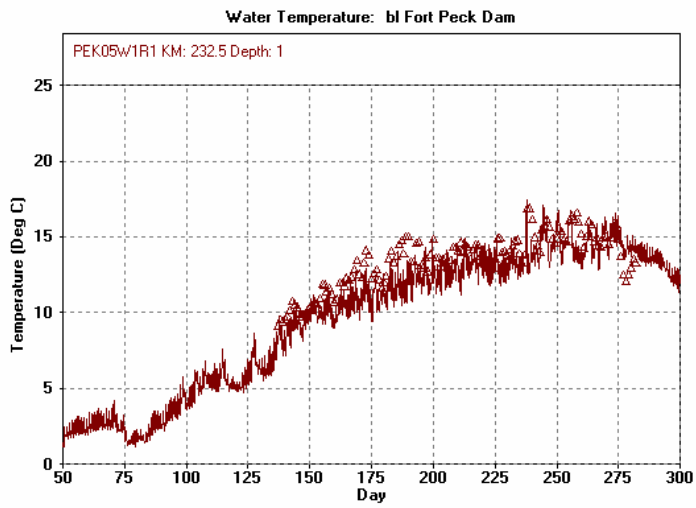


Plate 43. 2005 Missouri River simulated water temperatures calibrated to measured water temperatures.

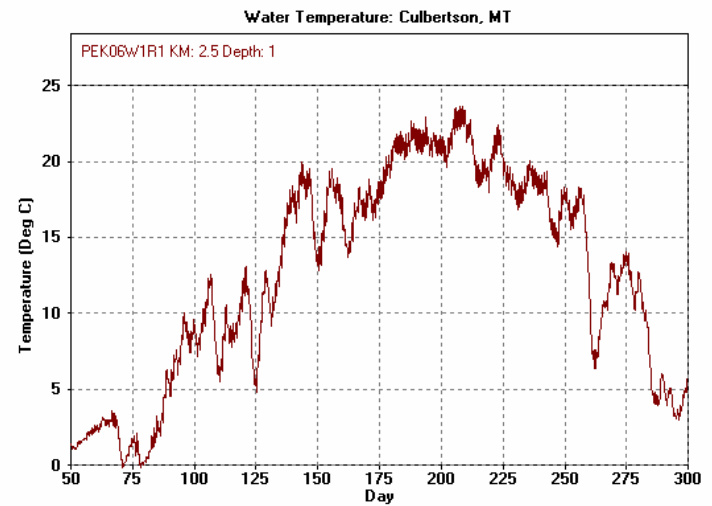
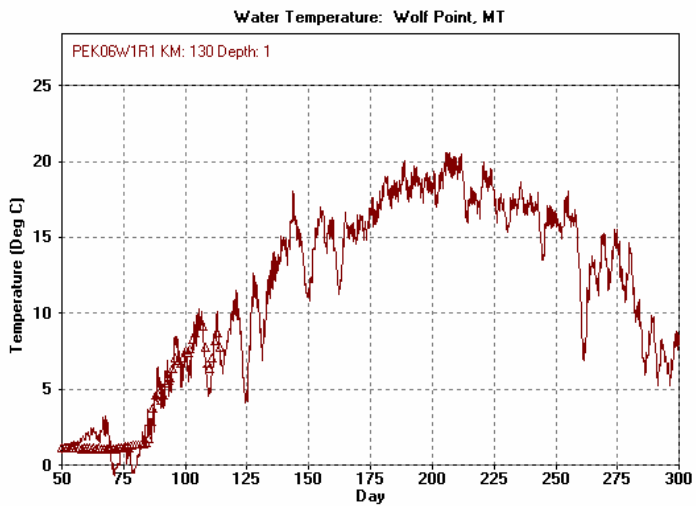
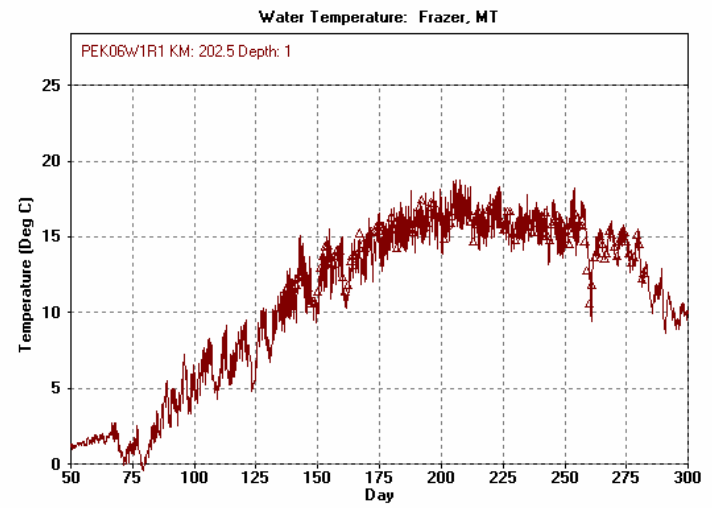
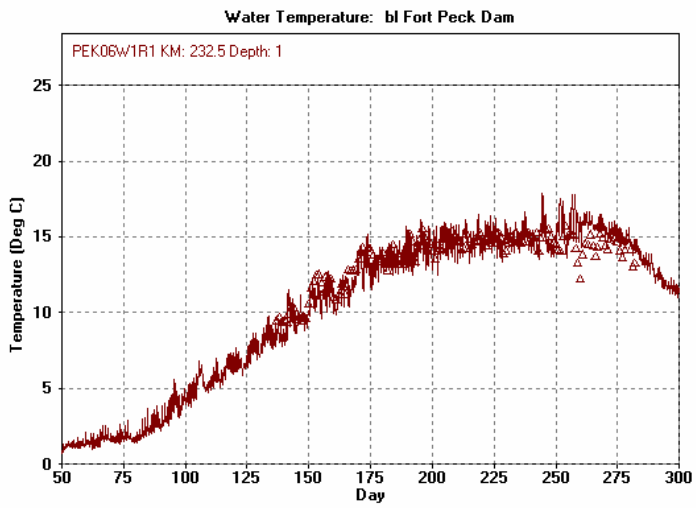


Plate 44. 2006 Missouri River simulated water temperatures calibrated to measured water temperatures.

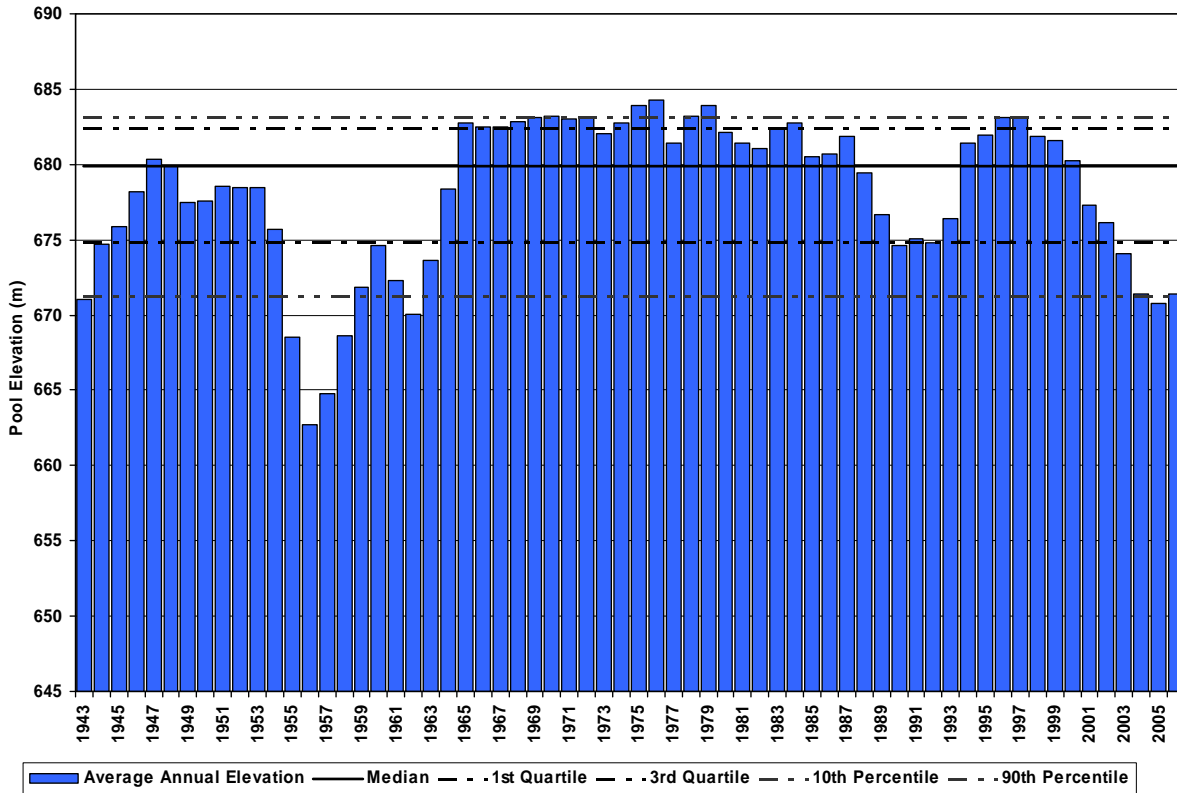


Plate 45. Fort Peck Lake average annual lake elevation and statistics.

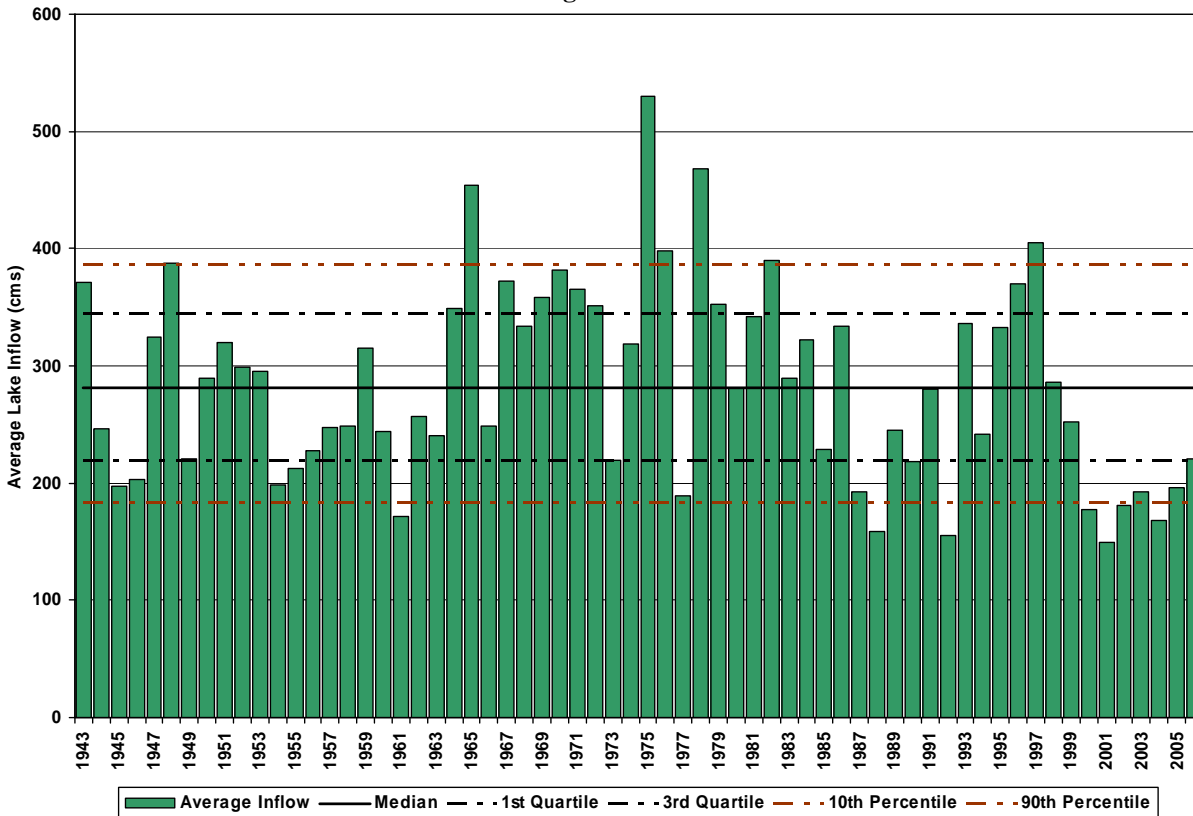


Plate 46. Fort Peck Lake average annual lake inflow and statistics.

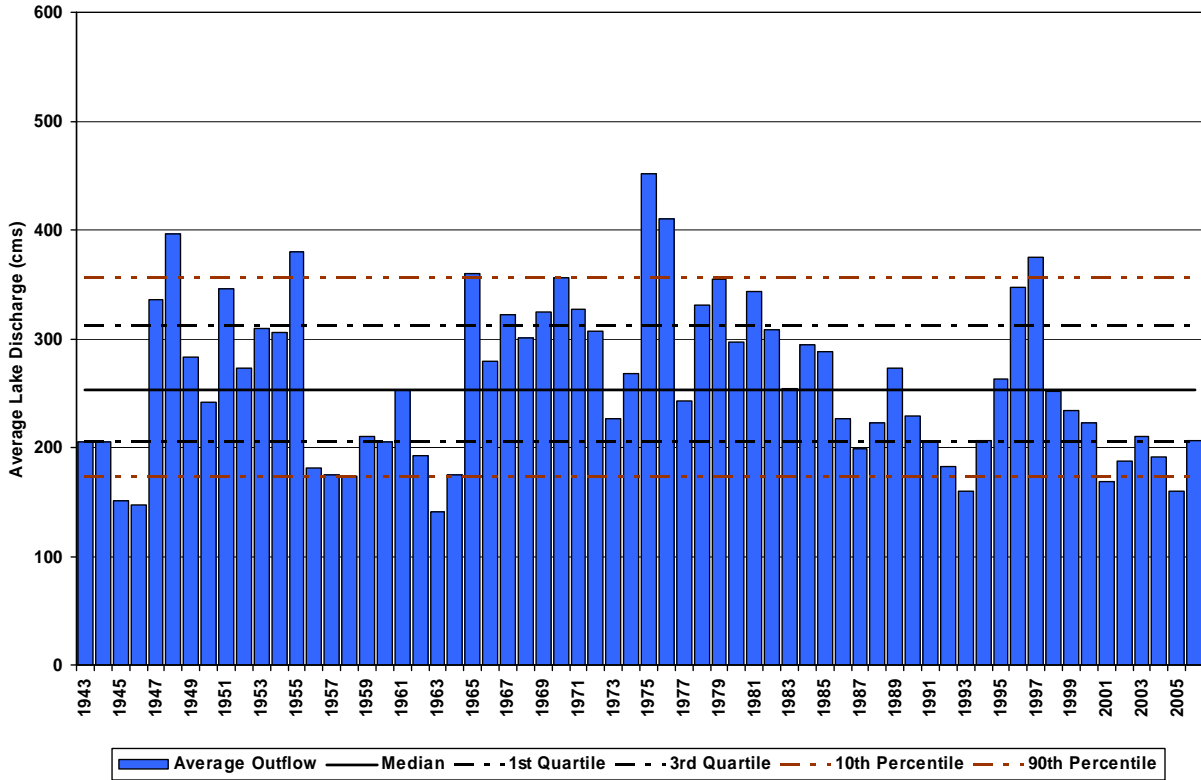


Plate 47. Fort Peck Lake average annual lake outflow and statistics.

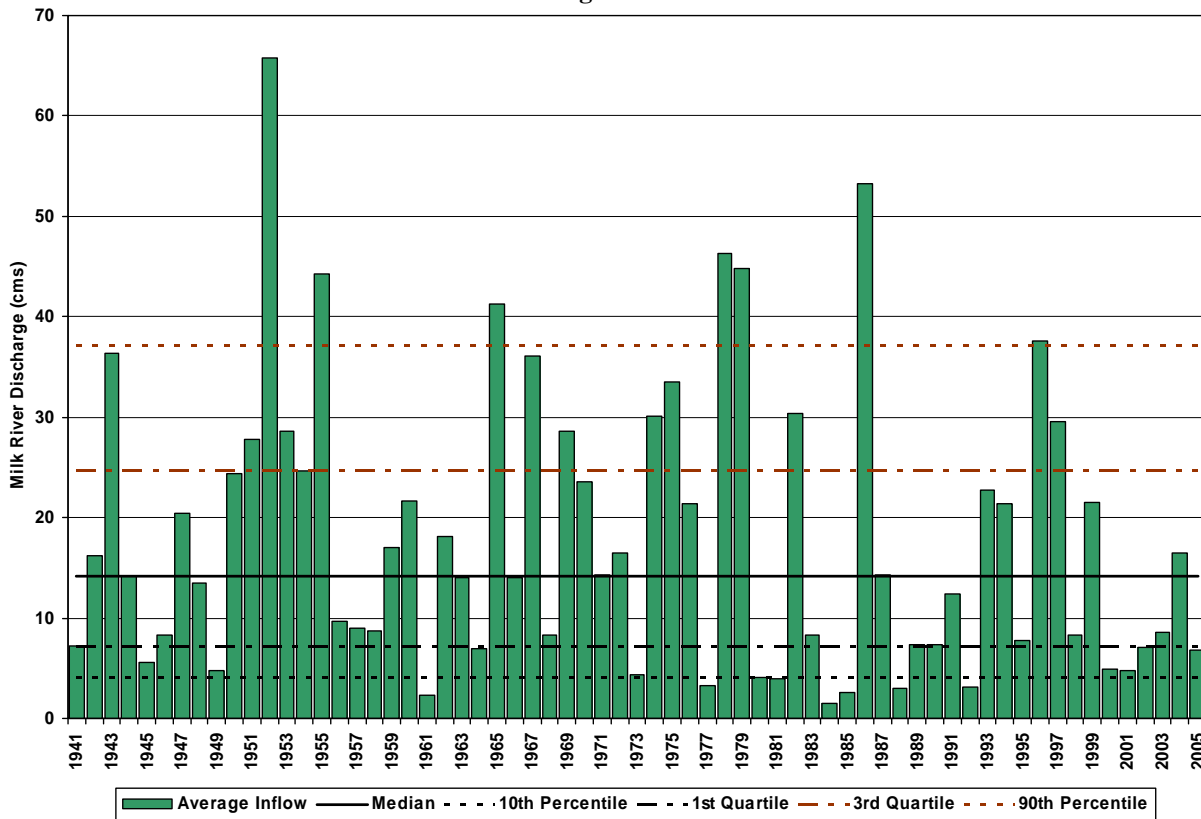


Plate 48. Milk River at Nashua, MT, annual discharge and statistics.

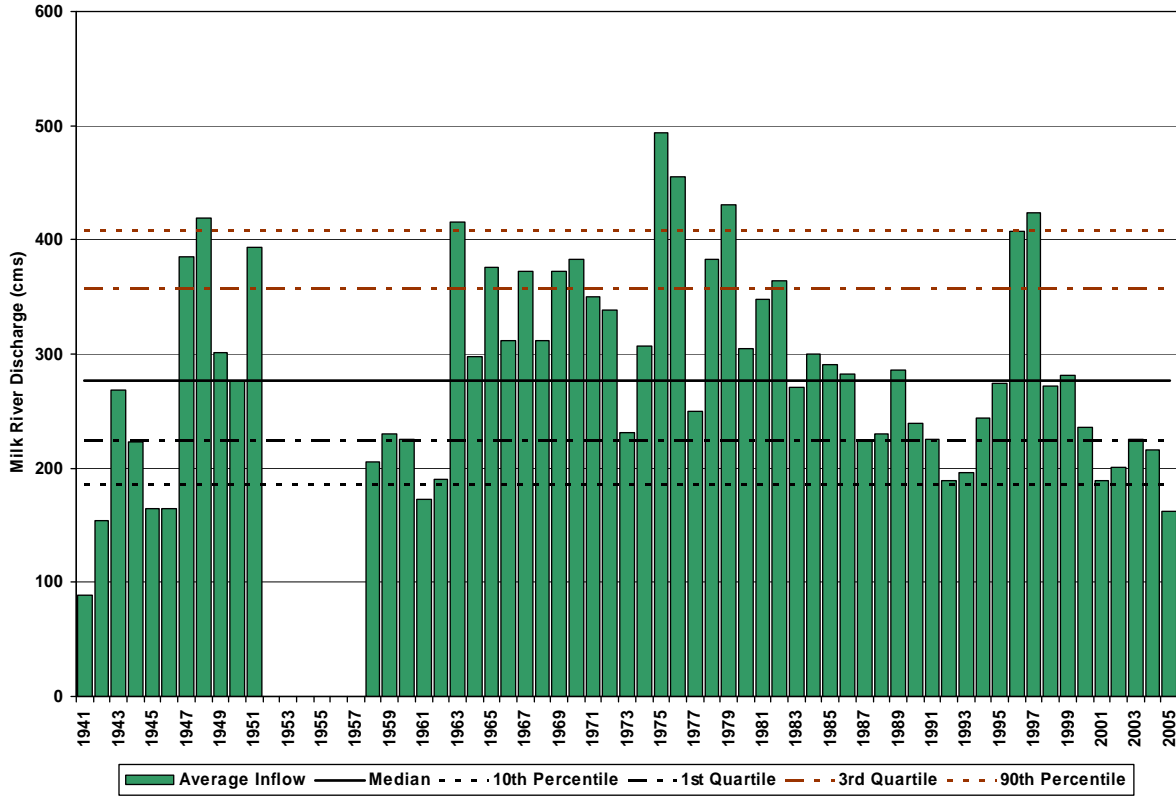


Plate 49. Missouri River at Culbertson, MT, annual discharge and statistics.

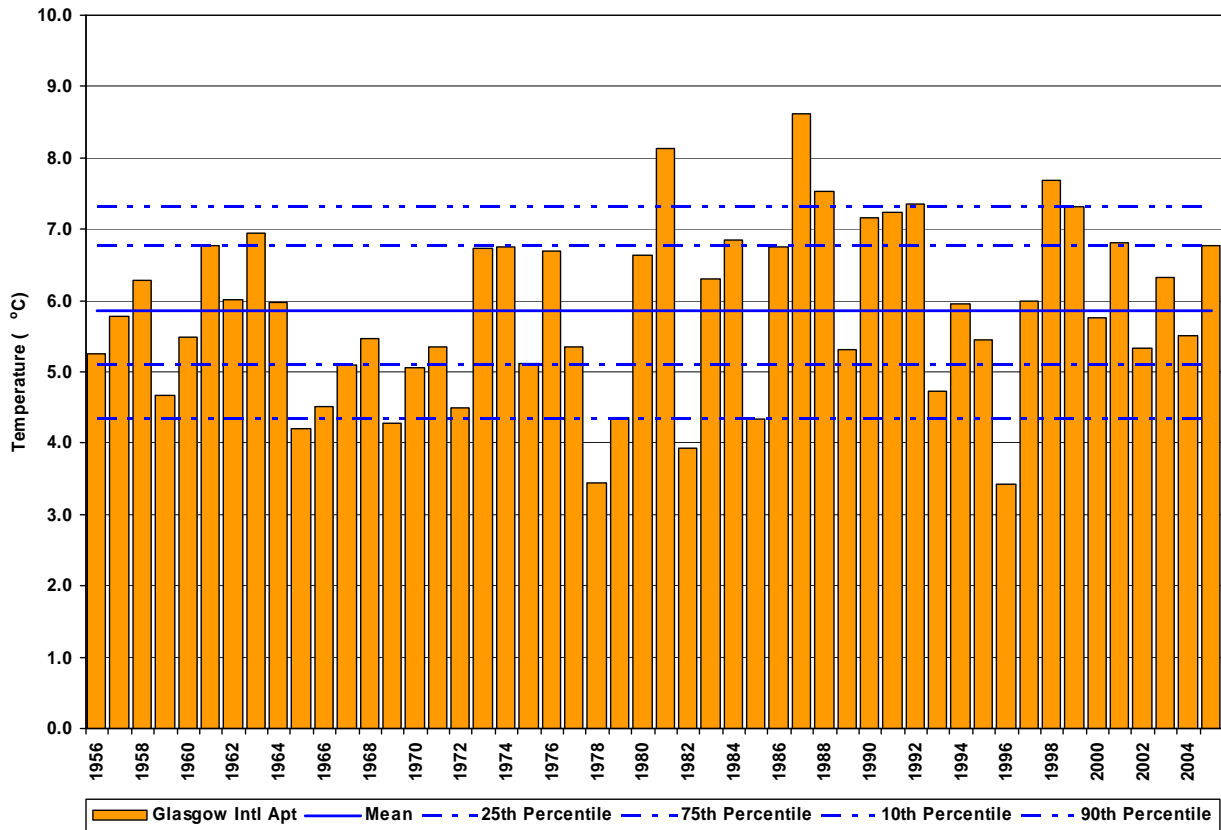


Plate 50. Glasgow, MT, International Airport average annual temperature (°C) and statistics.