

TA7
W34c
no. W-96-1
c. 3

**US Army Corps
of Engineers**
Waterways Experiment
Station

Contract Report W-96-1
July 1996

US-CE-C Property of the
United States Government

Water Quality Research Program

Sediment-Water Fluxes and Sediment Analyses in Chesapeake Bay: Tidal Fresh Potomac River and Maryland Main Stem

*by Walter R. Boynton, Janet M. Barnes,
Barbara J. Weaver, L. L. Magdeburger
Chesapeake Biological Laboratory*

*Peter Sampou
Horn Point Environmental Laboratory*

WES

Approved For Public Release; Distribution Is Unlimited

Research Library
US Army Engineer Waterways
Experiment Station
Vicksburg, Mississippi

WQRP

Prepared for Headquarters, U.S. Army Corps of Engineers

35336628

TA7
W34c
no. W-96-1
c.3

**Water Quality
Research Program**

Contract Report W-96-1
July 1996

Sediment-Water Fluxes and Sediment Analyses in Chesapeake Bay: Tidal Fresh Potomac River and Maryland Main Stem

by Walter R. Boynton, Janet M. Barnes,
Barbara J. Weaver, L. L. Magdeburger

Chesapeake Biological Laboratory
Box 38
Solomons, MD 20688-0038

Peter Sampou

Horn Point Environmental Laboratory
Cambridge, MD 21613-0775

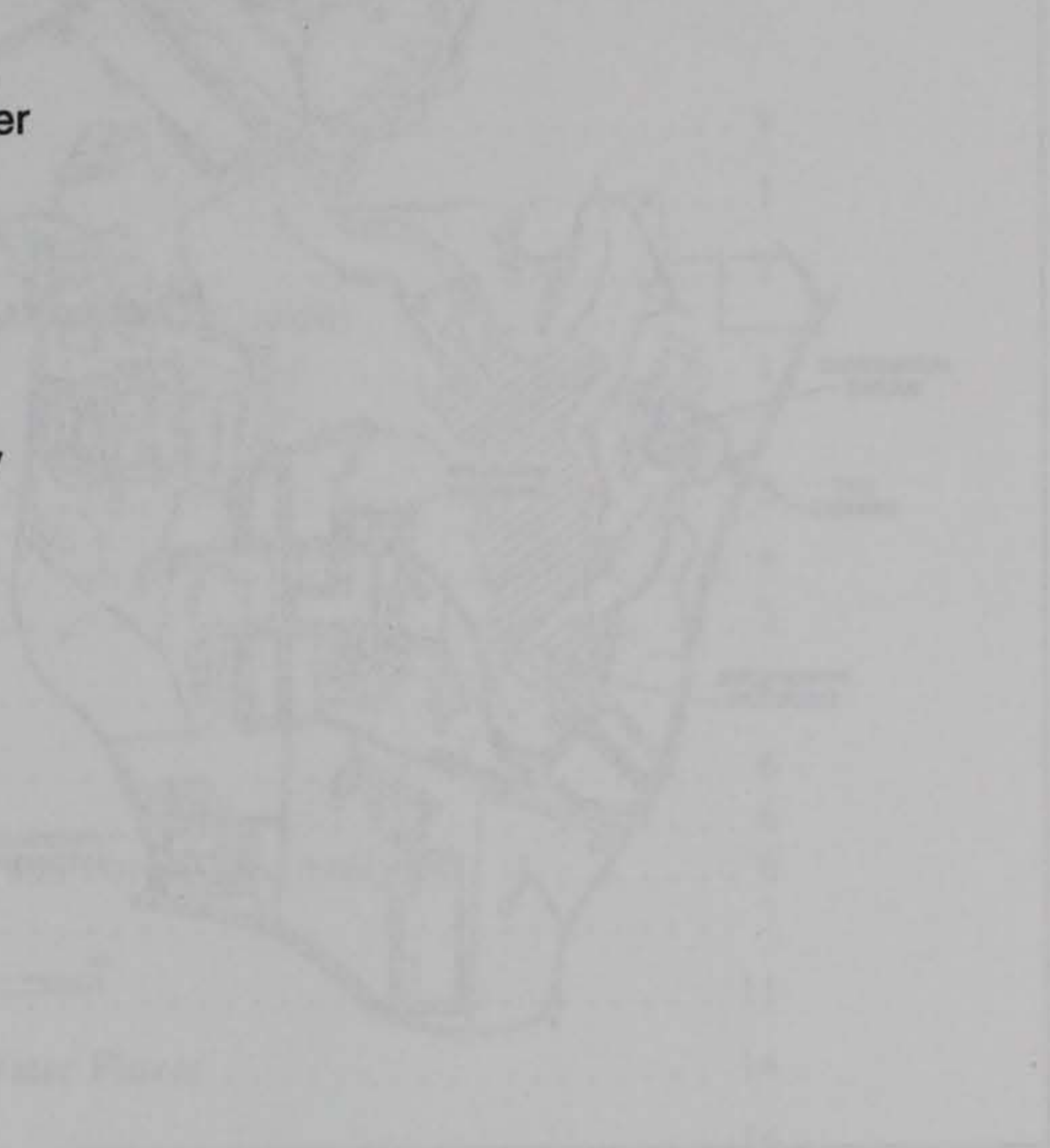

Final report

Approved for public release; distribution is unlimited

Prepared for **U.S. Army Corps of Engineers**
Washington, DC 20314-1000

Monitored by **U.S. Army Engineer Waterways Experiment Station**
Vicksburg, MS 39280-6199



**US Army Corps
of Engineers**
Waterways Experiment
Station

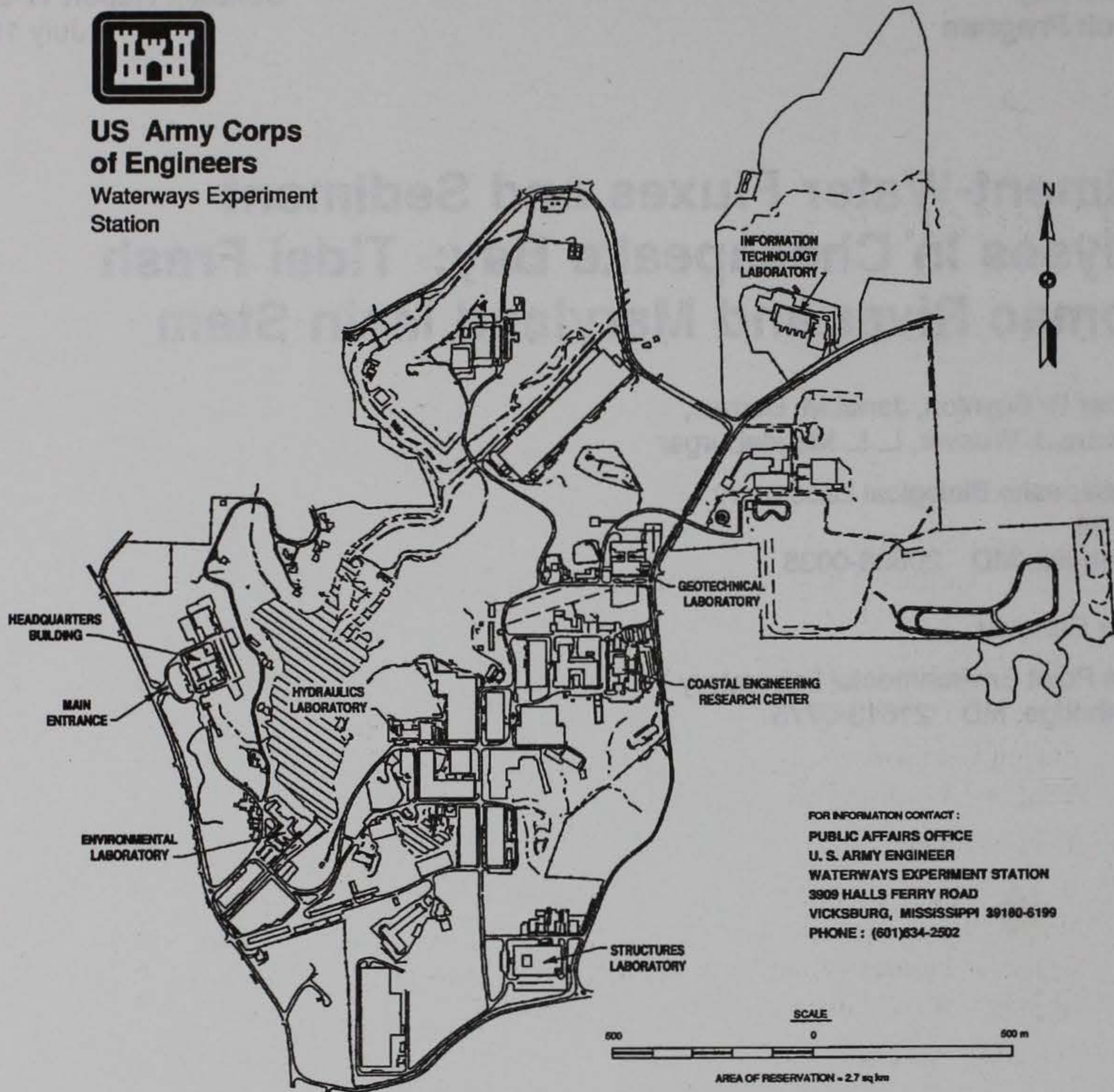

Waterways Experiment Station Cataloging-in-Publication Data

Sediment-water fluxes and sediment analyses in Chesapeake Bay : tidal fresh Potomac River and Maryland Main Stem / by Walter R. Boynton ... [et al.] ; prepared for U.S. Army Corps of Engineers ; monitored by U.S. Army Engineer Waterways Experiment Station. 145 p. : ill. ; 28 cm. -- (Contract report ; W-96-1)

Includes bibliographical references.

1. Sedimentation analysis. 2. River sediments -- Potomac River -- Measurement. 3. Sedimentation and deposition -- Chesapeake Bay (Md.) -- Measurement. I. Boynton, Walter R. II. United States. Army. Corps of Engineers. III. U.S. Army Engineer Waterways Experiment Station. IV. Water Quality Research Program. V. Title: Tidal fresh Potomac River and Maryland Main Stem. VI. Series: Contract report (U.S. Army Engineer Waterways Experiment Station) ; W-96-1.

TA7 W34c no.W-96-1

Contents

Preface	v
1—Introduction	1
Background Information	1
Conceptual Model of Estuarine Metabolic Processes in Chesapeake Bay	1
Objectives	2
2—Project Description	3
Station Locations	3
Sampling Frequency	3
3—Field Methods	6
Water Column Profiles	6
Bottom Water Analyses	6
Sediment Profiles—Solid Phase and Pore Water Analyses	6
Sediment-Water Fluxes	7
4—Chemical Analyses	11
5—Summary of Major Sediment-Water Fluxes	14
Sediment Oxygen Consumption	14
Ammonium and Phosphate	14
Total Carbon Dioxide	18
References	20
Appendix A: Water Column Profile Data Tables	A1
Appendix B: Bottom Water Dissolved Nutrient Data Tables	B1
Appendix C: Sediment Samples: Solid Phase Data Tables; Dissolved Phase Data Tables	C1
Appendix D: Incubation Core Nutrient Concentration Data Tables	D1
Appendix E: Sediment-Water Oxygen and Nutrient Flux Data Tables	E1

List of Figures

Figure 1.	Map of Potomac River and Maryland main stem: station locations occupied during 1994	4
Figure 2.	Schematic diagram of incubation chamber	8
Figure 3.	Potomac River and Maryland main stem sediment oxygen consumption rates for 1994	15
Figure 4.	Potomac River and Maryland main stem ammonium flux rates for 1994	16
Figure 5.	Potomac River and Maryland main stem phosphate flux rates for 1994	17
Figure 6.	Potomac River and Maryland main stem total carbon dioxide flux rates for 1994	19

Preface

The work reported herein was conducted as part of the Water Quality Research Program (WQRP), Work Unit 32694. The WQRP is sponsored by Headquarters, U.S. Army Corps of Engineers (HQUSACE), and is assigned to the U.S. Army Engineer Waterways Experiment Station (WES) under the purview of the Environmental Laboratory (EL). Funding was provided under Department of the Army Appropriation No. 96X3121, General Investigation. The WQRP is managed under the Environmental Resources Research and Assistance Programs (ERRAP), Mr. J. L. Decell, Manager. Mr. Robert Gunkel, Jr., was Assistant Manager, ERRAP, for the WQRP. Program Monitors during this study were Messrs. Frederick B. Juhle and Rixie Hardy and Dr. John Bushman, HQUSACE.

Principal Investigator of the Work Unit was Dr. Carl F. Cerco, Water Quality and Contaminant Modeling Branch (WQCMB), Environmental Processes and Effects Division (EPED), EL. The study was conducted under the supervision of Dr. Mark S. Dortch, Chief, WQCMB, and Mr. Donald L. Robey, Chief, EPED. Report review was provided by Dr. Barry Bunch, WQCMB, and Mr. Ross Hall, WQCMB. Dr. John W. Keeley was Director of EL.

This report was prepared by Dr. Walter Boynton, Chesapeake Biological Laboratory (CBL), Solomons, MD, Dr. Pete Sampou, Horn Point Environmental Laboratory, Cambridge, MD, Ms. Janet Barnes, CBL, Ms. Barbara Weaver, CBL, and Mr. L. Magdeburger, CBL. The report describes field studies to provide data for development and calibration of a freshwater sediment diagenesis model.

At time of publication of this report, Dr. Robert W. Whalin was Director of WES, and COL Bruce K. Howard, EN, was WES Commander.

1 Introduction

Background Information

Recent water quality models and nutrient mass balance budgets indicate that sediment-water exchanges of oxygen and nutrients across the sediment-water interface are a major feature of estuarine nutrient cycles. These cycles play an important role in determining estuarine water quality and habitat conditions. For example, during summer periods when water quality conditions are typically poorest (i.e., anoxic conditions in deep water and algal blooms), sediment releases of nutrients (e.g., nitrogen and phosphorus) and consumption of oxygen are often highest.

These models also indicate that the total metabolic processes within estuarine sediments and the resulting fluxes into and out of these sediments are very dynamic. Past studies by the Ecosystem Processes Component of the Maryland Chesapeake Bay Water Quality Monitoring Program have concentrated mainly on the processes of aerobic metabolism and the input of organic matter and nutrients from both natural and anthropogenic sources driving these processes. However, other studies (Jorgensen 1977; Howes, Dacey, and King 1984; Howes, Dacey, and Teal 1985) indicate that in some cases over 50 percent of the sediment metabolic processes can be attributed to anaerobic metabolism. Anaerobic and aerobic metabolism are tightly coupled not only with each other, but also with the standing stocks of many compounds in the top few centimeters of sediment, including particulate and dissolved organic matter and various other reduced compounds.

Conceptual Model of Estuarine Metabolic Processes in Chesapeake Bay

Metabolic processes associated with estuarine sediments have a considerable influence on water quality and habitat conditions in the Bay and its tributaries. Nutrients and organic matter enter the Bay from a variety of sources, including sewage treatment plant effluents, fluvial inputs, nonpoint drainage, and direct rainfall on Bay waters. These dissolved nutrients are rapidly incorporated into particulate matter via biological, chemical, and physical

mechanisms. Much of this particulate material then sinks to the bottom and is potentially available for remineralization. Essential nutrients released during the decomposition of organic matter may then be utilized by algal communities. A portion of this newly produced organic matter sinks to the bottom, contributing to the development of anoxic conditions and loss of habitat for important infaunal, shellfish, and demersal fish communities. The regenerative capacities and the potentially large nutrient storages within bottom sediments ensure the ample return flux of nutrients from sediments to the water column, which sustains continued phytoplankton growth. This growth in turn supports deposition of organics to deep waters, creating anoxic conditions typically associated with the eutrophication of estuarine systems.

Once these anoxic conditions develop, anaerobic metabolism begins to dominate the system. The oxidation of available organic matter under anoxic conditions occurs via the reduction of compounds other than oxygen: sulfate reduction dominates in regions of the Chesapeake Bay where sulfate is readily available while methanogenesis dominates in the freshwater regions.

Objectives

The objectives of this U.S. Army Engineer Waterways Experiment Station (WES) project included collecting data to aid in the ongoing characterization of the present state of the Chesapeake Bay and its tributaries (including spatial and seasonal variation). The variables measured include measurements of the stocks of several organic compounds associated with the top 10 cm of sediment, measurements of the stocks of the compounds involved in the metabolic processes in the sediments, and measurements of the resulting fluxes into and out of the sediments. These data are available to further calibrate the coupled hydrodynamic/water quality/sediment flux model of Chesapeake Bay, especially for applications to low salinity regions. The information collected in this program can be compared with data from other elements of the Chesapeake Bay Monitoring Program to gain a better understanding of the processes affecting Chesapeake Bay water quality, especially in low salinity regions.

2 Project Description

Station Locations

The four WES station locations for the sediment-water fluxes and the sediment analyses are identified in Figure 1 and Table 1. There are three stations located in the tidal fresh Potomac River and one station in the Chesapeake Bay Maryland main stem. These stations were visited four times from May - October 1994 (Table 2).

Sampling Frequency

The station sampling frequency is based on the seasonal patterns of sediment water exchanges observed in previous studies conducted in the Chesapeake Bay region (Kemp and Boynton 1980; Kemp and Boynton 1981; Boynton et al. 1982; Boynton and Kemp 1985) as well as previous sediment-oxygen and nutrient exchange (SONE), mini-SONE, and benthic exchange and sediment transformation (BEST) data. These studies indicated several distinct periods over an annual cycle including the following:

- a.* April and May, when the spring phytoplankton bloom occurs and water column nutrient concentrations are high (particularly nitrate).
- b.* June, influenced by the presence of a large macrofaunal community.
- c.* July, August, and September, when macrofaunal biomass is low, but water temperature and water column metabolic activity is high and anoxia prevalent in deeper waters.
- d.* October and November, when anoxia is not present and the macrofaunal community abundance low but re-establishing.

Previous studies also indicate that short-term temporal (day-week) variation in these exchanges is small; however, considerable differences in the magnitude and characteristics of fluxes appear among distinctively different estuarine zones (i.e., tidal fresh versus mesohaline regions). Since benthic fluxes are small when water temperatures fall below 12 to 15 °C, monitoring during

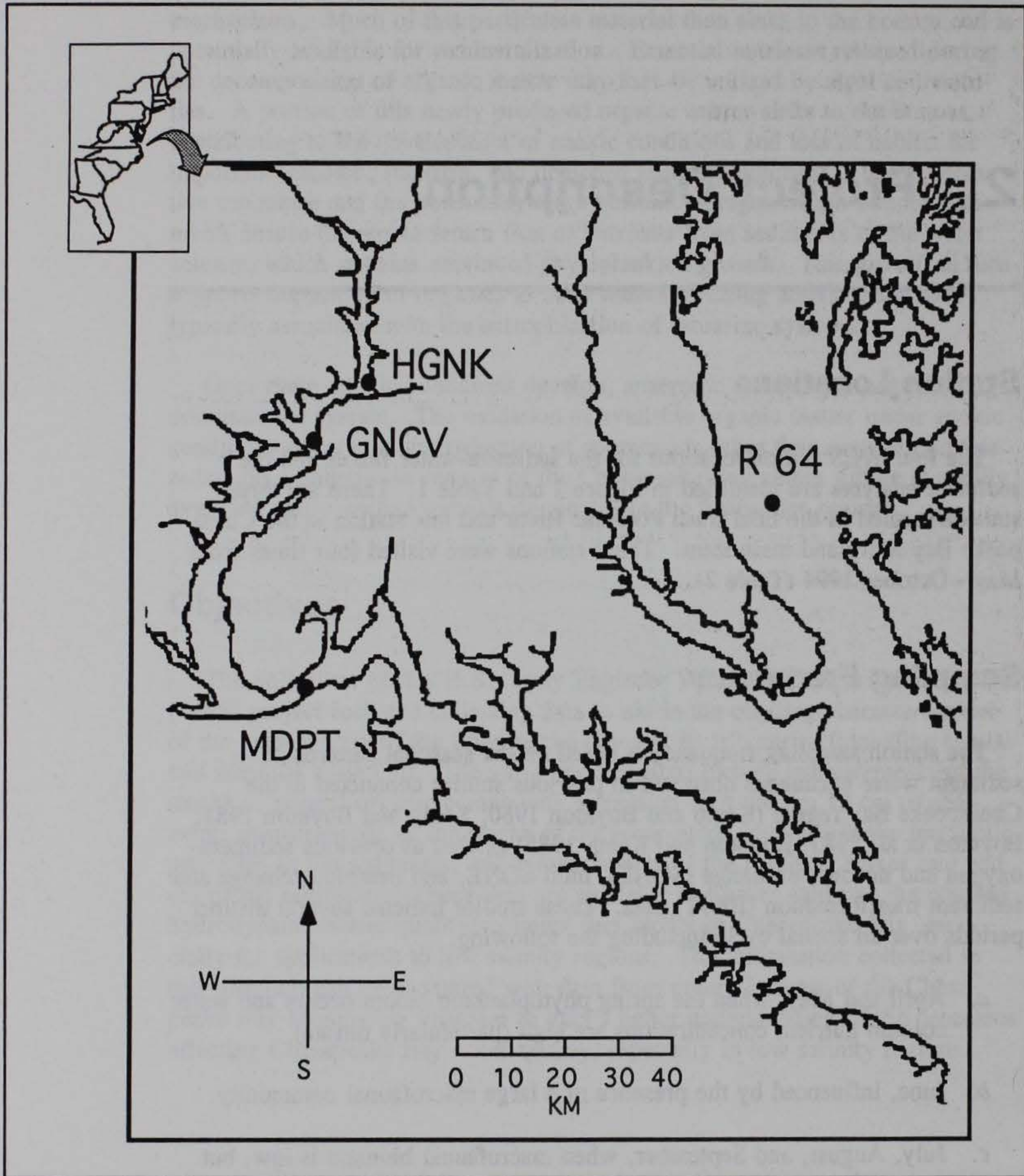

Figure 1. Map of Potomac River and Maryland main stem: station locations occupied during 1994

winter and early spring does not yield as much useful information as when large fluxes are observed from May through October. For example, during this warmer time, N and P fluxes exceed total annual loading from other sources by as much as a factor of 4.

**Table 1
Numerical Water Quality and Contaminant Modeling (EL-22) Tidal
Fresh Potomac River and Maryland Main Stem Stations: Station
Name, Code, and Location**

Station	Code	Location	
		Latitude	Longitude
Hedge Neck	HGNK	38' 44.17"	77' 02.03"
Gunston Cove	GNCV	38' 39.33"	77' 07.45"
Maryland Point	MDPT	38' 21.18"	77' 11.34"
Main Stem	R 64	38' 33.59"	76' 25.63"

**Table 2
Sampling Frequency: Stations and Sampling Dates**

Station	May	July	August	October
HGNK	19	12	9	13
GNCV	19	12	9	13
MDPT	20	13	10	14
R 64	21	14	11	17

3 Field Methods

Water Column Profiles

At each of the four WES stations, vertical water column profiles of temperature, conductivity, salinity, and dissolved oxygen were measured at 2-m intervals (0.5- or 1-m intervals at shallow stations) from the surface to the bottom. A submersible pump and a Hydrolab S-II Data Sonde CTD were used to obtain the readings. Water column turbidity was measured using a Secchi disc. (See Appendix A.)

Bottom Water Analyses

Near-bottom (approximately 1 m) water samples were collected using a high volume submersible pump system. Samples were immediately processed and frozen for later analysis of the following compounds: ammonium (NH_4^+), nitrite plus nitrate ($\text{NO}_2^- + \text{NO}_3^-$), dissolved inorganic phosphorous (PO_4^{3-}), siliceous acid $\text{Si}(\text{OH})_4$, dissolved organic nitrogen (DON), dissolved organic phosphorus (DOP), dissolved organic carbon (DOC), total carbon dioxide (TCO_2), total iron (Fe), total manganese (Mn), and sulfate (SO_4^{2-}) concentrations. The bottom water pH was also measured. (See Appendix B.)

Sediment Profiles—Solid Phase and Pore Water Analyses

Zero to ten-centimeter sediment composites were subcored from the 6-in. cores and prepared for solid and pore water analyses. (See Appendix C.) For the solid phase analyses, 50-ml centrifuge tubes (each one containing a 1-in. in diameter 0- to 10-cm subcore) were frozen and returned to either Nutrient Analytical Services Laboratory (NASL) at the Chesapeake Biological Laboratory (CBL) or to Dr. Peter Sampou at the Horn Point Environmental Laboratory (HPEL). Solid phase analyses were conducted by NASL and included particulate carbon (PC), particulate nitrogen (PN), particulate phosphorus (PP), and total and active chlorophyll-*a* concentrations. Solid phase

compounds analyzed by Dr. Sampou at HPEL included biogenic silica (BiSi), acid volatile sulfur (AVS), chromate reducible sulfur (CRS), iron (Fe), calcium carbonate (CaCO_3) phosphorus (using both the Aspila and Ruttenberg extractions), and manganese (Mn^{+2}).

To prepare the composites for pore water analyses for NASL, 50-ml centrifuge tubes containing the 0- to 10-cm composites were centrifuged at 4,000 rpm for 10 min; pore water was then filtered and frozen. NASL analyzed pore waters for NH_4^+ , $\text{NO}_2^- + \text{NO}_3^-$, PO_4^{-3} , Si(OH)_4 , alkalinity (Alk), DOC, DON, and DOP.

Dr. Sampou's centrifuge tubes containing sediments for pore water analyses were held in ice, but not frozen. These were later analyzed for chloride (Cl^-), SO_4^{-2} , calcium (Ca^{+2}), manganese (Mn^{+2}), Fe, and TCO_2 .

Pore water pH was measure directly in the centrifuge pore water using a Hanna Piccolo Plus ATC Temperature pH meter.

To prepare pore water H_2S samples for analyses by Dr. Douglas Capone's laboratory at CBL, a 2-cm slice of a large box core was packed into a centrifuge tube, spun for 10 min at 4,000 rpm, then filtered into a preweighed scintillation vial containing 0.5 ml of zinc acetate. Five depths were analyzed: 0 to 2, 2 to 4, 4 to 6, 6 to 8, and 8 to 10 cm. The large core was divided into two halves, side A and side B. Two replicates were taken at each depth, one sample from side A and one from side B. After sampling in the field, the samples were kept on ice.

To prepare pore water methane and porosity samples for analyses in Dr. Capone's laboratory, two 3-ml syringes (with cut off ends) of sediment were extracted at each 2-cm interval to a depth of 10 cm. Again the large box core was divided into two halves, side A and B, and one sample taken from each side at each depth. Each syringe of sediment was injected into a glass serum vial. The vial was sealed using a rubber serum cap and a crimp top, then frozen.

Sediment-Water Fluxes

Three intact sediment cores were obtained at each WES station using a modified Bouma box corer. These sediment cores, each contained in a 15- by 30-cm Plexiglas microcosm (Figure 2), constitute the basic system where changes in oxygen, nutrient, and other compound concentrations are determined. A decrease in these overlying water concentrations implies uptake (either biologically or chemically) of the compounds by the sediments. Conversely, an increase in concentration implies release by the sediments. (See Appendixes D and E.) An overview of the measurement techniques follows.

After deployment and retrieval of the box corer, the Plexiglas microcosm containing the sediment core is visually inspected for disturbances such as

Enlarged View of Top Plate

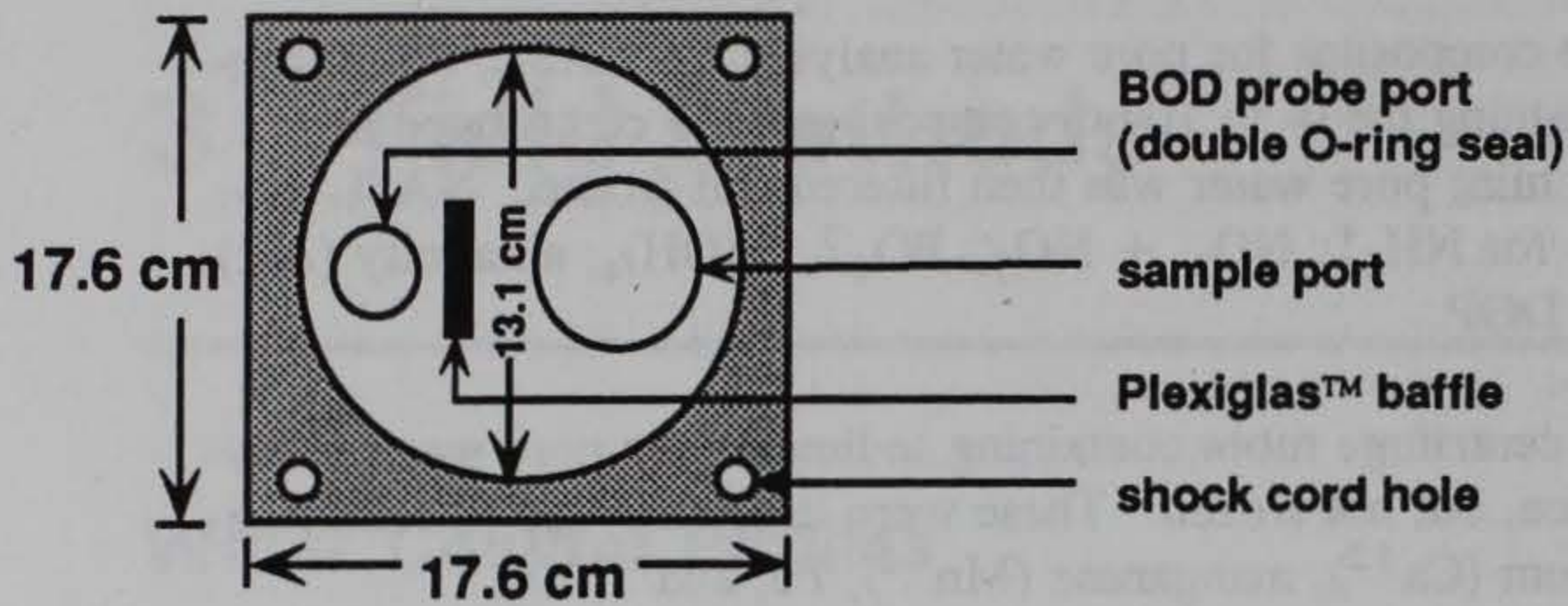

Cross Section of Incubation Chamber

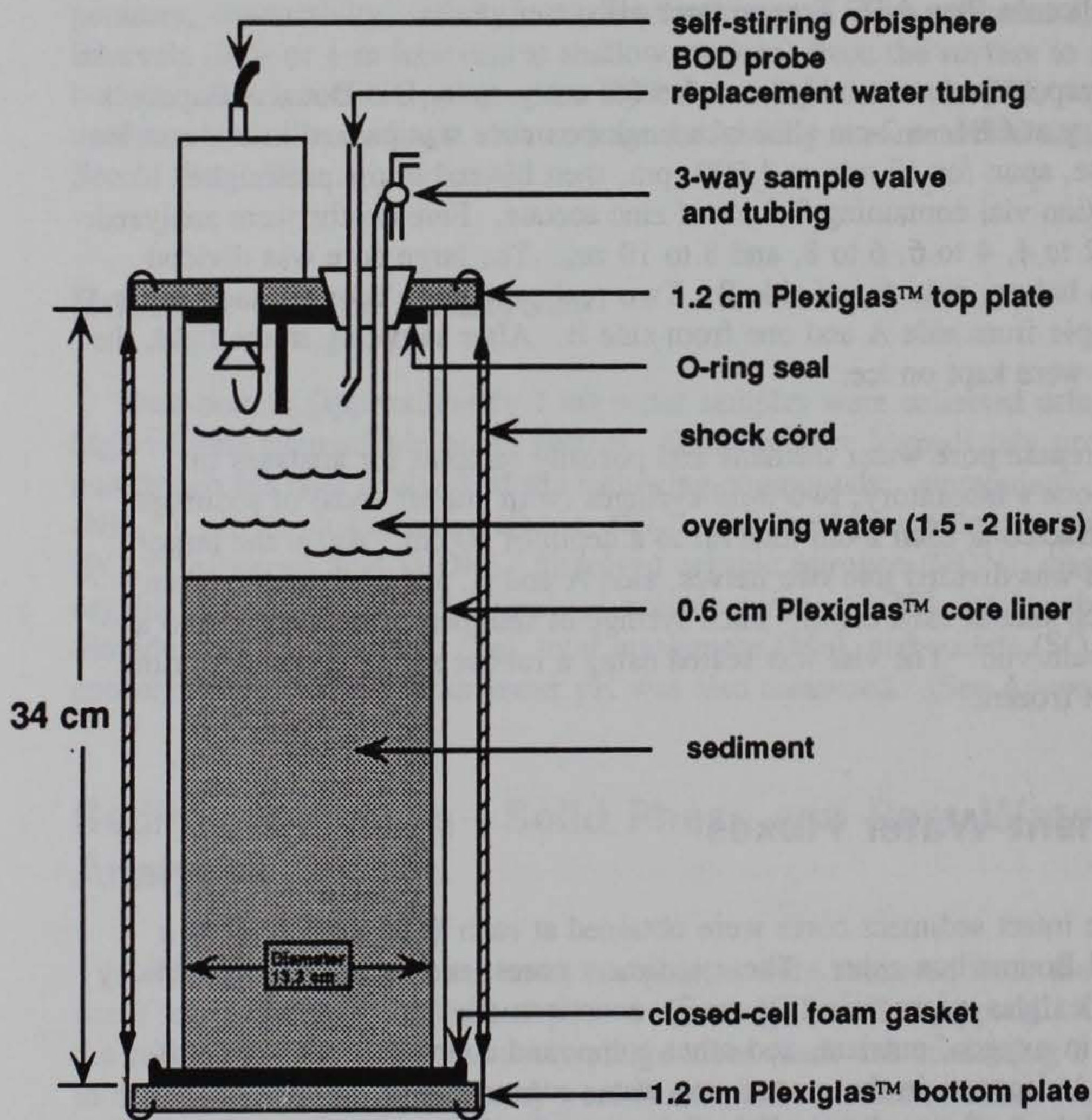

Figure 2. Schematic diagram of incubation chamber

large macro fauna or cracks in the sediments surface, and for proper core height. If the core is satisfactory, the microcosm is equipped with an O-ring sealed top containing ports for probes and water column sampling plus a neoprene gasket sealed bottom. The sealed microcosms are placed in a darkened bottom water-filled holding tank until all of the necessary cores are acquired.

A fourth microcosm is filled with bottom water (but no sediment) to serve as a blank. The blank receives the exact same treatment as the cores with sediments. Fluxes recorded from the bottom water blank microcosm are subtracted from the fluxes obtained in the sediment core microcosms to remove any possible water column-only chemical and biological reactions from the final flux calculations.

Immediately prior to beginning the actual flux incubation, the overlying water in each microcosm (including the blank) is slowly replaced with fresh bottom water to ensure that the water quality conditions in each core closely resemble in situ conditions. (Note: in situ conditions are determined by the CTD water column profile and the bottom water sample, which is analyzed for the same compounds measured during the flux experiment.)

The microcosms are placed in a darkened, temperature-controlled circulating water bath to maintain in situ temperature and light conditions. An oxygen probe containing a stirring device is inserted into one of the ports on the top of each microcosm. The stirring device ensures gentle circulation without sediment resuspension in the microcosm. Another port in each microcosm top is fitted with a device used to sample the overlying water while leaving the microcosm completely sealed.

The microcosms are incubated for 4 hr. Every hour, oxygen concentrations are recorded, plus overlying water samples are extracted to measure the various compound concentrations. (Note: as a water sample is extracted, an equal amount of bottom water from a reservoir is simultaneously pulled into the microcosm.)

At each WES station, extracted overlying water samples were immediately filtered, frozen, then later analyzed for NH_4^+ , $\text{NO}_3^- + \text{NO}_2^-$, PO_4^{3-} , $\text{Si}(\text{OH})_4$, DON, DOP, and DOC. Whole water samples were extracted for total CO_2 , Fe, and Mn fluxes. Each sample for total carbon dioxide analysis was slowly injected into a small BOD bottle, fixed with mercuric chloride, sealed with the BOD cap, then water sealed. These samples were stored on board in coolers at room temperature. Overlying water samples for iron and manganese analyses were injected into AA vials (5 ml per vial) then fixed with ultra pure nitric acid (3 μl HNO_3 per milliliter of sample). These samples were stored at room temperature.

The overlying water pH was measured at each time point using a Hanna Piccolo pH meter.

All of these fluxes are estimated by calculating the mean rate of change in concentration over the incubation period, correcting for dilution, and converting the volumetric rate to a flux using the volume:area ratio of each core.

In situ methane fluxes were measured by Dr. Sampou. A brief description of the field and laboratory methods follows. For a more in-depth description, see Martens and Klump (1980).

An inverted polypropylene cone (0.086-m² area) is suspended in the water column near each station (at the same station depth) approximately 1 m off the bottom. The cone was weighted with 72 oz (2,041 g) of lead and is tethered to a surface float. The hanging depth of the cone is adjustable. The length of the line from the anchor to the surface float is roughly two times the water column depth.

These methane traps were suspended over the sediment for approximately 24 hr (encompassing two low tides when gas ebullition may be affected by hydrostatic head change). Using a gas-tight 10-ml Hamilton syringe, a 5- to 10-ml subsample of the total gas captured in the cone is extracted. This subsample, in the syringe, is transported back to the laboratory and immediately analyzed for methane using a Shimadzu (model GC-8A) gas chromatograph equipped with a thermal conductivity detector (detection limit: 1-percent methane). Prior to sample analysis, five standards were run on the gas chromatograph using pure methane plus atmospheric gas mixtures. Quality control is better than plus/minus 3 percent for the standards. The precision of the traps is calculated to be between 20 and 50 percent due to the heterogeneity of methane ebullition inherent in sediments.

The methane flux calculation follows: (volume of trapped gas) (percent of methane gas) (1 mole of gas/22.4 l) (core area/square meter) (1/incubation time hours).

4 Chemical Analyses

Standard oceanographic and estuarine methods of chemical analysis were used for all determinations of dissolved and particulate materials (see Table 3).

Code	Description of Problem
HH	Sample Not Taken
NI	Data for This Variable Are Considered Noninterpretable
NS	Data for This Variable Are Considered Nonsignificant
S	Sample Container Broken During Analysis

Analyses performed by NASL, Chesapeake Biological Laboratory, used the following techniques:

- a. Nitrate (NO_3^-) + nitrite (NO_2^-), nitrite (NO_2^-), ammonia (NH_4^+), and dissolved inorganic phosphorus (DIP) followed the procedure of the U.S. Environmental Protection Agency (EPA), EPA-600/4-79-020 (1979).
- b. Siliceous acid ($\text{Si}(\text{OH})_4$) followed the procedure of Technicon Industrial System (1977).
- c. Dissolved organic carbon (DOC) using automated persulfate digestion (Menzel and Vaccaro 1964).
- d. Dissolved organic nitrogen (DON) and dissolved organic phosphorus (DOP): subtraction of inorganic N and P from the total dissolved concentrations of N and P which were obtained by a persulfate oxidation technique (D'Elia, Steudler, and Corwin 1977 and Valderrama 1981).

- e. Particulate phosphorus (PP) using acid digestion of muffled-dry samples (Aspila, Agemian, and Chau 1976).
- f. Particulate carbon (PC) and particulate nitrogen (PN) analyses used high temperature combustion with a model 240B Perkin-Elmer Elemental Analyzer (Zimmerman, Keefe, and Bashe 1992).
- g. Chlorophyll-*a* analysis utilized acetone extraction followed by fluorometric detection (Strickland and Parsons 1972; Shoaf and Lium 1976).
- h. Pore water carbonate alkalinity (Alk) via acidification and detection with O.I. model 700 carbon analyzer (Menzel and Vaccaro 1964).

Analyses performed by Dr. Peter Sampou, Horn Point Environmental Laboratory, used the following techniques:

- a. Sediment calcium carbonate (CaCO_3) using acidification followed by gas chromatography.
- b. Sulfate (SO_4^{-2}) and chloride (Cl) detection with Dionex Corporation chromatograph and conductivity detection method following the procedures of EPA 600/4-87/026 (1987).
- c. Total carbon dioxide (TCO_2) using coulometric method of Johnson et al. (1987).
- d. Ruttenberg phosphorus extraction following the procedures of Ruttenberg (1992).
- e. Sediment phosphate (PO_4) analyses used acid digestion of muffled-dry samples (Aspila, Agemian, and Chau 1976).
- f. Biogenic silica (BiSi) followed the wet chemical dissolution technique of Eggimann, Manheim, and Betzen (1980).
- g. Iron (Fe) and manganese (Mn) followed the procedures of Canfield (1989).
- h. Calcium (Ca) utilized flame atomic absorption followed by spectrometric detection (Zimmerman, Keefe, and Bashe 1992).
- i. Acid volatile sulfide (AVS) and chromate reducible sulfide (CRS) following the procedures of Morse and Cornwell (1987).
- j. Methane (CH_4) flux analyses used a gas trap and GC analysis with a flame ionization detector.

Analyses performed by Dr. Douglas Capone's laboratory, Chesapeake Biological Laboratory, used the following techniques:

- a. Hydrogen sulfide (H_2S) followed the colorimetric technique of Cline (1969).
- b. Pore water methane (CH_4) and porosity used the methods of Capone and Kiene (1985).

On Board Measurements:

- a. Sediment oxygen demand utilized an Orbisphere 2112 oxygen electrode.
- b. pH measurements used a pH/ion selective electrode.

5 Summary of Major Sediment-Water Fluxes

Graphic summaries of the major fluxes observed are provided to show seasonal patterns and to give an overall indication of the magnitude of sediment-water oxygen and nutrient exchanges (Figures 3-6). Winter samples were not taken due to low activity during cold weather (below 12 to 15 °C) resulting in low to nonexistent fluxes. Figures are provided for sediment oxygen consumption (SOC), ammonium (NH_4^+), dissolved inorganic phosphate (PO_4^{-3}), and total carbon dioxide (TCO_2). These fluxes are particularly important because the data can be used to infer the types and magnitudes of processes controlling water quality conditions. Graphics are not provided for the following fluxes: pH, nitrite plus nitrate ($\text{NO}_2^- + \text{NO}_3^-$), dissolved silicate (Si(OH)_4), dissolved organic carbon (DOC), dissolved organic nitrogen (DON), total dissolved nitrogen (TDN), dissolved organic phosphorus (DOP), total dissolved phosphorus (TDP), iron (Fe), and manganese (Mn).

Sediment Oxygen Consumption

Sediment oxygen consumption (SOC) in the tidal fresh Potomac River ranged from $-0.69 \text{ g O}_2 \text{ m}^{-2} \text{ day}^{-1}$ at Maryland Point in October to -2.04 at Gunston Cove in August. Rates at the Maryland main stem (R 64) ranged from $0.0 \text{ g O}_2 \text{ m}^{-2} \text{ day}^{-1}$ in August to -1.32 in October. SOC rates at the main stem station appear to follow seasonal peak patterns observed in other areas of the Bay. SOC rates at Potomac River stations peaked later in the season than at the main stem station (Figure 3).

Ammonium and Phosphate

Ammonium (NH_4^+) fluxes in the Potomac River are moderate to high and comparable with other enriched areas of the Bay (Figure 4). Phosphate (PO_4^{-3}) fluxes were low in comparison with other areas of the Bay (Figure 5). Low rates of phosphate release from sediment is indicative of oxidized sediment. Phosphorus binds to iron under oxic conditions and is released

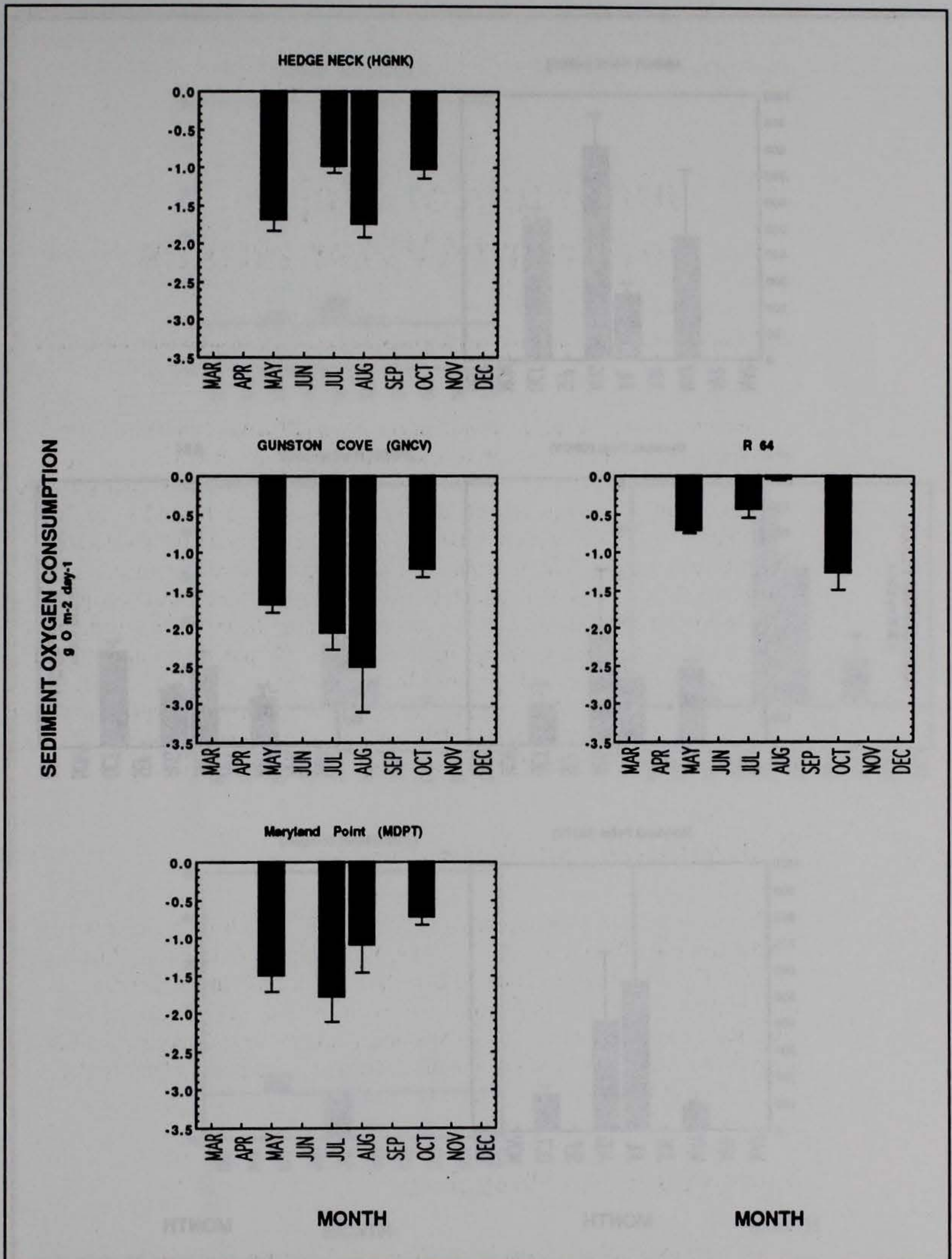

Figure 3. Potomac River and Maryland main stem sediment oxygen consumption rates for 1994

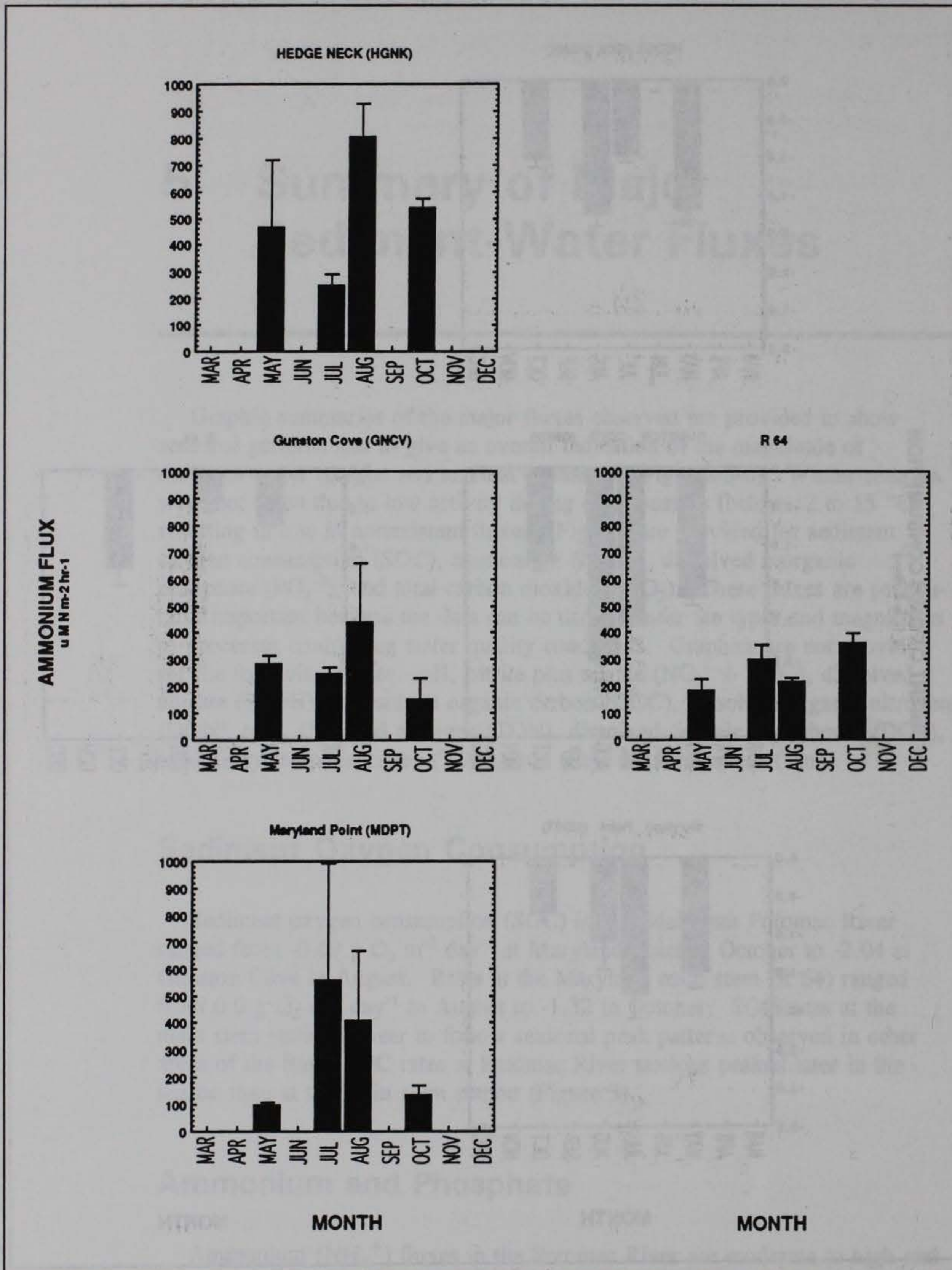

Figure 4. Potomac River and Maryland main stem ammonium flux rates for 1994

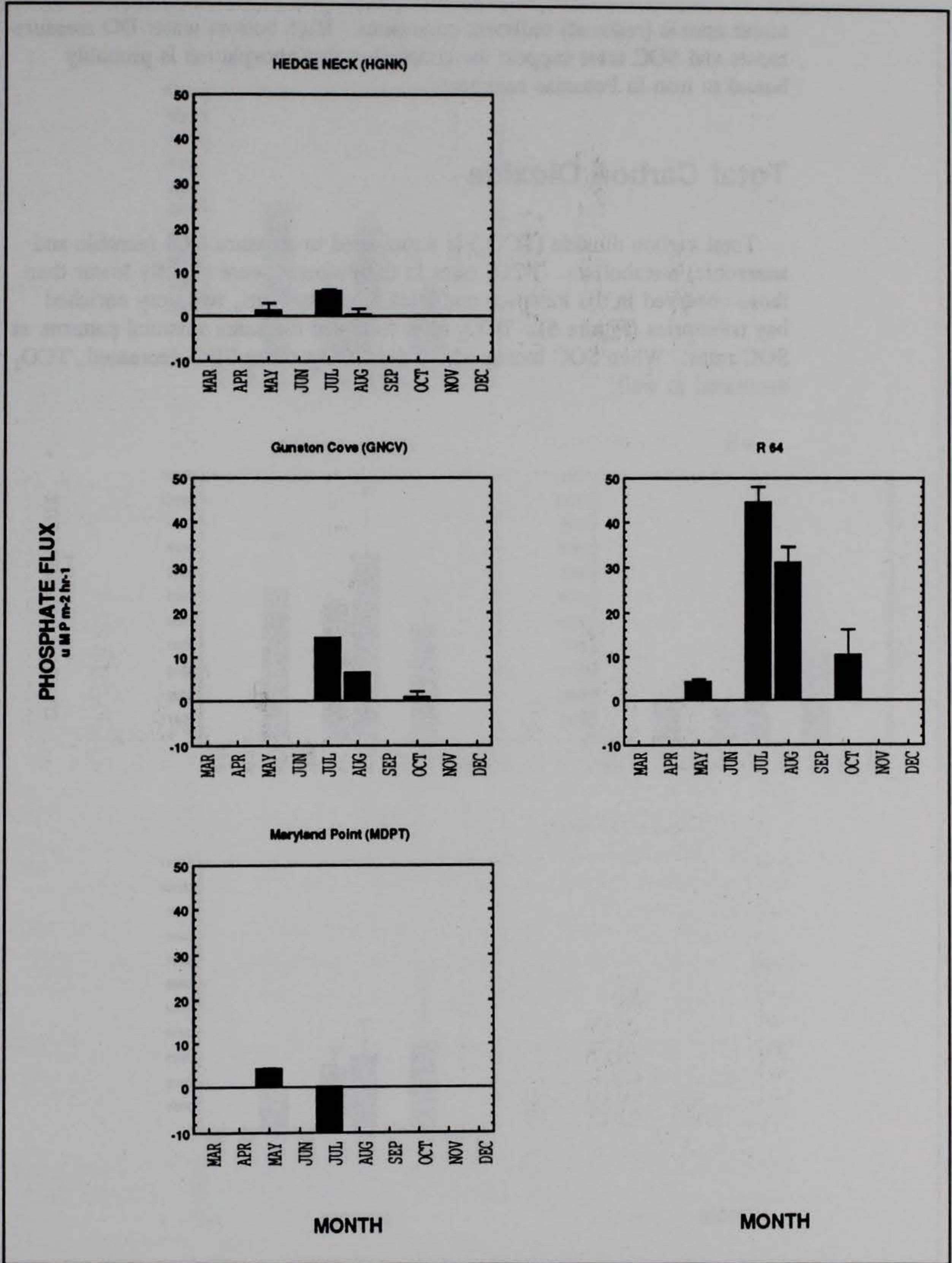

Figure 5. Potomac River and Maryland main stem phosphate flux rates for 1994

under anoxic (reduced) sediment conditions. High bottom water DO measurements and SOC rates support the conclusion that phosphorus is probably bound to iron in Potomac sediments.

Total Carbon Dioxide

Total carbon dioxide (TCO_2) is a tool used to measure total (aerobic and anaerobic) metabolism. TCO_2 rates in the Potomac were slightly lower than those observed in the Patapsco and Back River systems, two very enriched bay tributaries (Figure 6). TCO_2 rates followed the same seasonal patterns as SOC rates. When SOC increased, so did TCO_2 ; when SOC decreased, TCO_2 decreased as well.

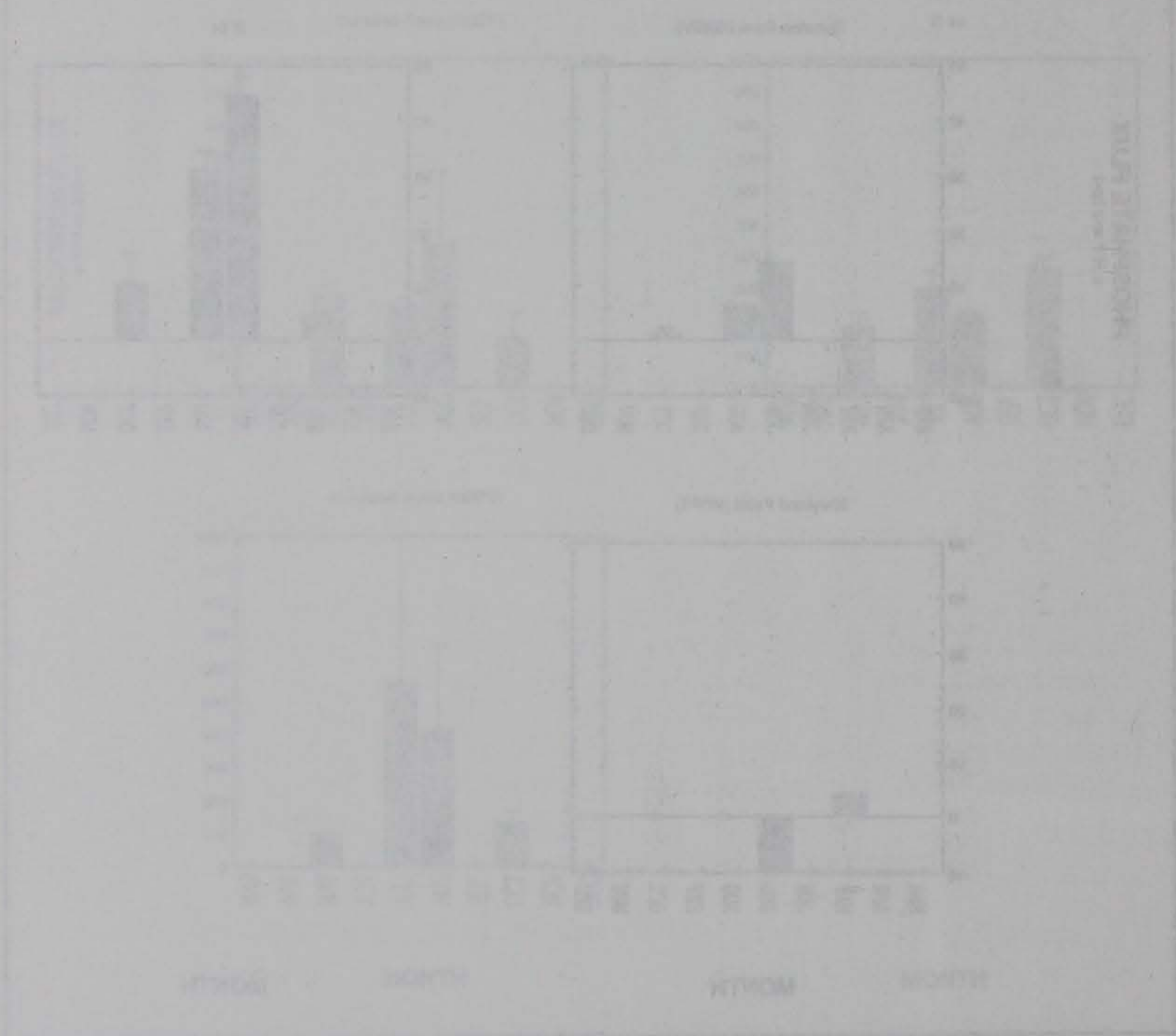

Figure 6. Total carbon dioxide (TCO_2) rates in the Potomac, Patapsco, and Back River systems, showing seasonal patterns similar to SOC rates.

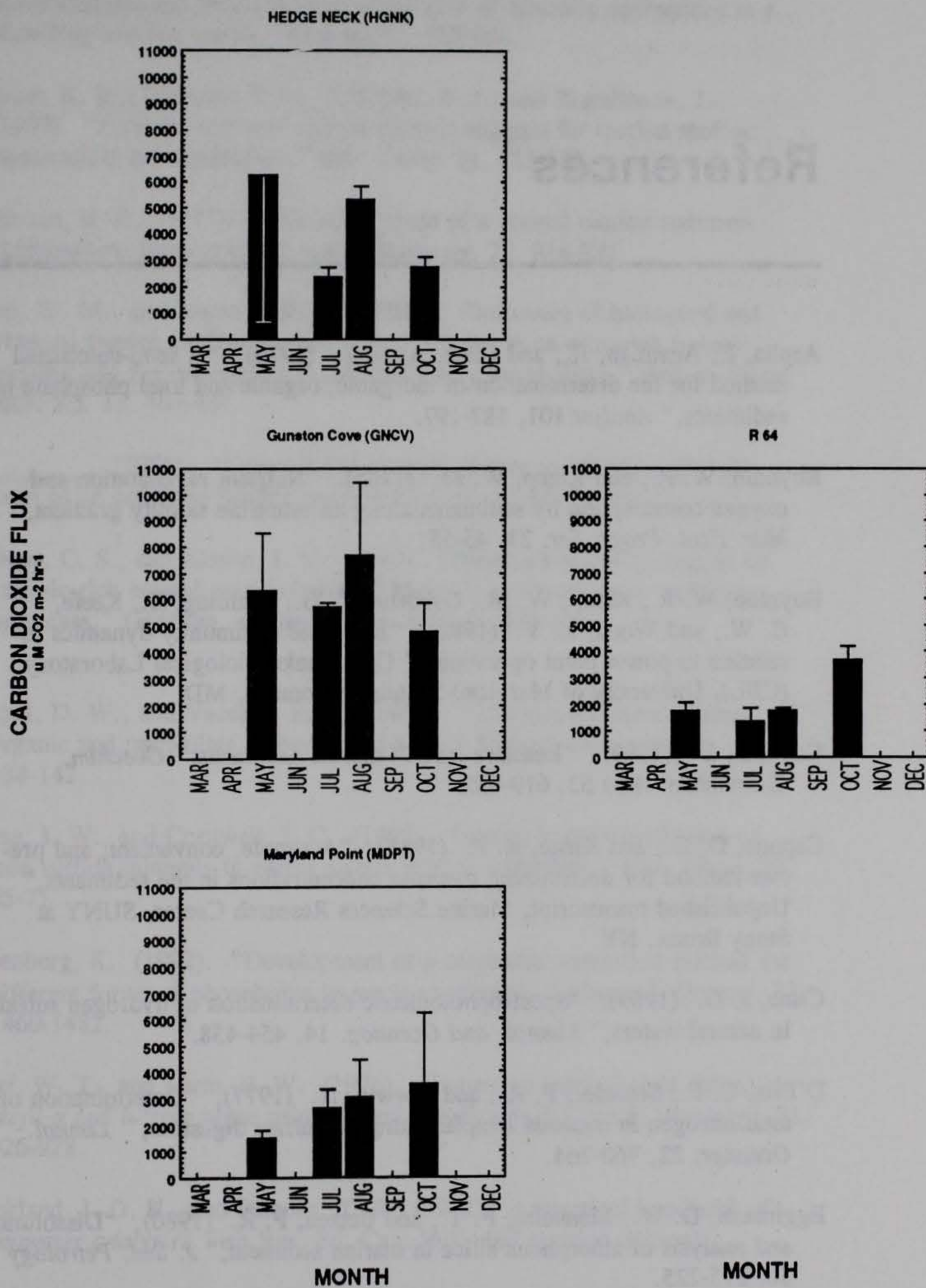

Figure 6. Potomac River and Maryland main stem total carbon dioxide flux rates for 1994

References

- Aspila, I., Agemian, H., and Chau, A. S. Y. (1976). "A semi-automated method for the determination of inorganic, organic and total phosphate in sediments," *Analyst* 101, 187-197.
- Boynton, W. R., and Kemp, W. M. (1985). "Nutrient regeneration and oxygen consumption by sediments along an estuarine salinity gradient," *Mar. Ecol. Progr. Ser.* 23, 45-55.
- Boynton, W. R., Kemp, W. M., Osborne, C. G., Spalding, E., Keefe, C. W., and Wood, K. V. (1982). "Estuarine community dynamics in relation to power plant operations," Chesapeake Biological Laboratory (CBL), University of Maryland System, Solomons, MD.
- Canfield, D. (1989). "Reactive iron in marine sediments," *Geochim. Cosmochim. Acta* 53, 619-632.
- Capone, D. G., and Kiene, R. P. (1985). "A simple, convenient, and precise method for determining methane concentrations in the sediments," Unpublished manuscript, Marine Sciences Research Center, SUNY at Stony Brook, NY.
- Cline, J. D. (1969). "Spectrophotometric determination of hydrogen sulfide in natural waters," *Limnol. and Oceanog.* 14, 454-458.
- D'Elia, C. F., Steudler, P. A., and Corwin, N. (1977). "Determination of total nitrogen in aqueous samples using persulfate digestion," *Limnol. Oceanogr.* 22, 760-764.
- Eggemann, D. W., Manheim, F. T., and Betzen, P. R. (1980). "Dissolution and analysis of amorphous silica in marine sediment," *J. Sed. Petrology* 50, 215-225.
- Howes, B. L., Dacey, J. W. H., and King, G. M. (1984). "Carbon flow through oxygen and sulfate reduction pathways in salt marsh sediments," *Limnol. Oceanogr.* 29, 1037-1051.

- Howes, B. L., Dacey, J. W. H., and Teal, J. M. (1985). "Annual carbon mineralization and below ground production of *Spartina alterniflora* in a New England salt marsh," *Ecology* 66, 595-605.
- Johnson, K. M., Sieburth, J. M., Williams, P. J., and Brandstrom, L. (1987). "Coulometric total carbon dioxide analysis for marine studies: Automation and calibration," *Mar. Chem.* 21, 117-133.
- Jorgensen, B. B. (1977). "The sulfur cycle of a coastal marine sediment (Limfjorden, Denmark)," *Limnol. Oceanogr.* 22, 814-832.
- Kemp, W. M., and Boynton, W. R. (1980). "Influence of biological and physical factors on dissolved oxygen dynamics in an estuarine system: Implications for measurements of community metabolism," *Estuar. Coast. Mar. Sci.* 11, 407-431.
- _____. (1981). "External and internal factors regulating metabolic rates of an estuarine benthic community," *Oecologia* 51, 19-27.
- Martens, C. S., and Klump, J. V. (1980). "Biogeochemical cycling in an organic-rich coastal marine basin-I. Methane sediment-water exchange processes," *Geochim. et Cosmochim. Acta* 44, 471-490.
- Menzel, D. W., and Vaccaro, R. F. (1964). "The measurement of dissolved organic and particulate carbon in seawater," *Limnol. Oceanogr.* 9, 138-142.
- Morse, J. W., and Cornwell, J. C. (1987). "Analysis and distribution of iron sulfide minerals in recent anoxic marine sediments," *Mar. Chem.* 22, 55-71.
- Ruttenberg, K. (1992). "Development of a sequential extraction method for different forms of phosphorus in marine sediments," *Limnol. Oceanogr.* 37, 1460-1482.
- Shoaf, W. T., and Lium, B. W. (1976). "Improved extraction of chlorophyll-*a* and *b* from algae using dimethyl sulfoxide," *Limnol. Oceanogr.* 21, 926-928.
- Strickland, J. D. H., and Parsons, T. R. (1972). *A practical handbook of seawater analysis*. Fish Res. Bd. Can. Bull. 167 (second edition).
- Technicon Industrial Systems. (1977). "Silicates in water and seawater," Industrial Method No. 186-72W/B, Technicon Industrial Systems, Terrytown, NY.

- U.S. Environmental Protection Agency (EPA). (1979). "Methods for chemical analysis of water and wastes," USEPA-600/4-79-020, Environmental Monitoring and Support Laboratory, Cincinnati.
- Valderrama, J. C. (1981). "The simultaneous analysis of total nitrogen and total phosphorus in natural waters," *Mar. Chem.* 10, 109-122.
- Zimmerman, C. F., Keefe, C. W., and Bashe, J. (1992). "Determination of carbon and nitrogen in sediments and particulates of estuarine/coastal waters using elemental analysis, Method 440.0, EPA/600/R-92/121.

Appendix A

Water Column Profile Data Tables

Station	Depth (m)	Temperature (°C)	Salinity (PSU)	Density (sigma-t)	Chlorophyll a (µg/L)	Chlorophyll b (µg/L)	Chlorophyll c (µg/L)	Chlorophyll total (µg/L)	OC2 (µg/L)	OC3 (µg/L)	OC4 (µg/L)	OC5 (µg/L)	OC6 (µg/L)	OC7 (µg/L)	OC8 (µg/L)	OC9 (µg/L)	OC10 (µg/L)	OC11 (µg/L)	OC12 (µg/L)	OC13 (µg/L)	OC14 (µg/L)	OC15 (µg/L)	OC16 (µg/L)	OC17 (µg/L)	OC18 (µg/L)	OC19 (µg/L)	OC20 (µg/L)	
001	0.5	18.5	35.2	1.024	0.5	0.1	0.1	0.7	0.1	0.1	0.1	0.1	0.1	0.1	0.1	0.1	0.1	0.1	0.1	0.1	0.1	0.1	0.1	0.1	0.1	0.1	0.1	0.1
001	1.0	18.2	35.1	1.023	0.4	0.1	0.1	0.6	0.1	0.1	0.1	0.1	0.1	0.1	0.1	0.1	0.1	0.1	0.1	0.1	0.1	0.1	0.1	0.1	0.1	0.1	0.1	0.1
001	1.5	17.8	34.9	1.022	0.3	0.1	0.1	0.5	0.1	0.1	0.1	0.1	0.1	0.1	0.1	0.1	0.1	0.1	0.1	0.1	0.1	0.1	0.1	0.1	0.1	0.1	0.1	0.1
001	2.0	17.5	34.8	1.021	0.2	0.1	0.1	0.4	0.1	0.1	0.1	0.1	0.1	0.1	0.1	0.1	0.1	0.1	0.1	0.1	0.1	0.1	0.1	0.1	0.1	0.1	0.1	0.1
001	2.5	17.2	34.7	1.020	0.1	0.1	0.1	0.3	0.1	0.1	0.1	0.1	0.1	0.1	0.1	0.1	0.1	0.1	0.1	0.1	0.1	0.1	0.1	0.1	0.1	0.1	0.1	0.1
001	3.0	17.0	34.6	1.019	0.1	0.1	0.1	0.2	0.1	0.1	0.1	0.1	0.1	0.1	0.1	0.1	0.1	0.1	0.1	0.1	0.1	0.1	0.1	0.1	0.1	0.1	0.1	0.1
001	3.5	16.8	34.5	1.018	0.1	0.1	0.1	0.1	0.1	0.1	0.1	0.1	0.1	0.1	0.1	0.1	0.1	0.1	0.1	0.1	0.1	0.1	0.1	0.1	0.1	0.1	0.1	0.1
001	4.0	16.6	34.4	1.017	0.1	0.1	0.1	0.1	0.1	0.1	0.1	0.1	0.1	0.1	0.1	0.1	0.1	0.1	0.1	0.1	0.1	0.1	0.1	0.1	0.1	0.1	0.1	0.1
001	4.5	16.5	34.3	1.016	0.1	0.1	0.1	0.1	0.1	0.1	0.1	0.1	0.1	0.1	0.1	0.1	0.1	0.1	0.1	0.1	0.1	0.1	0.1	0.1	0.1	0.1	0.1	0.1
001	5.0	16.4	34.2	1.015	0.1	0.1	0.1	0.1	0.1	0.1	0.1	0.1	0.1	0.1	0.1	0.1	0.1	0.1	0.1	0.1	0.1	0.1	0.1	0.1	0.1	0.1	0.1	0.1
001	5.5	16.3	34.1	1.014	0.1	0.1	0.1	0.1	0.1	0.1	0.1	0.1	0.1	0.1	0.1	0.1	0.1	0.1	0.1	0.1	0.1	0.1	0.1	0.1	0.1	0.1	0.1	0.1
001	6.0	16.2	34.0	1.013	0.1	0.1	0.1	0.1	0.1	0.1	0.1	0.1	0.1	0.1	0.1	0.1	0.1	0.1	0.1	0.1	0.1	0.1	0.1	0.1	0.1	0.1	0.1	0.1
001	6.5	16.1	33.9	1.012	0.1	0.1	0.1	0.1	0.1	0.1	0.1	0.1	0.1	0.1	0.1	0.1	0.1	0.1	0.1	0.1	0.1	0.1	0.1	0.1	0.1	0.1	0.1	0.1
001	7.0	16.0	33.8	1.011	0.1	0.1	0.1	0.1	0.1	0.1	0.1	0.1	0.1	0.1	0.1	0.1	0.1	0.1	0.1	0.1	0.1	0.1	0.1	0.1	0.1	0.1	0.1	0.1
001	7.5	15.9	33.7	1.010	0.1	0.1	0.1	0.1	0.1	0.1	0.1	0.1	0.1	0.1	0.1	0.1	0.1	0.1	0.1	0.1	0.1	0.1	0.1	0.1	0.1	0.1	0.1	0.1
001	8.0	15.8	33.6	1.009	0.1	0.1	0.1	0.1	0.1	0.1	0.1	0.1	0.1	0.1	0.1	0.1	0.1	0.1	0.1	0.1	0.1	0.1	0.1	0.1	0.1	0.1	0.1	0.1
001	8.5	15.7	33.5	1.008	0.1	0.1	0.1	0.1	0.1	0.1	0.1	0.1	0.1	0.1	0.1	0.1	0.1	0.1	0.1	0.1	0.1	0.1	0.1	0.1	0.1	0.1	0.1	0.1
001	9.0	15.6	33.4	1.007	0.1	0.1	0.1	0.1	0.1	0.1	0.1	0.1	0.1	0.1	0.1	0.1	0.1	0.1	0.1	0.1	0.1	0.1	0.1	0.1	0.1	0.1	0.1	0.1
001	9.5	15.5	33.3	1.006	0.1	0.1	0.1	0.1	0.1	0.1	0.1	0.1	0.1	0.1	0.1	0.1	0.1	0.1	0.1	0.1	0.1	0.1	0.1	0.1	0.1	0.1	0.1	0.1
001	10.0	15.4	33.2	1.005	0.1	0.1	0.1	0.1	0.1	0.1	0.1	0.1	0.1	0.1	0.1	0.1	0.1	0.1	0.1	0.1	0.1	0.1	0.1	0.1	0.1	0.1	0.1	0.1

Numerical Water Quality and Contaminant Modeling (EL-22)
 Tidal Fresh Potomac River and Maryland Mainstem
 Water Profile: Vertical profile of water characteristics

STATION	DATE	TIME	TOTAL DEPTH (m)	SECCHI DEPTH (m)	SAMPLE DEPTH (m)	TEMP (C)	COND (mmho/cm)	SALIN (psu)	DO (mg/L)	DO SAT (%)
MDPT	20MAY94	0908	10.0	0.5	0.5	18.0	0.7	0.0	8.50	89.7
					2.0	18.0	0.7	0.0	8.47	89.4
					4.0	18.0	0.7	0.0	8.39	88.6
					6.0	18.0	0.8	0.0	8.35	88.1
					8.0	17.9	0.8	0.1	8.44	89.0
					9.5	17.9	0.8	0.1	8.48	89.4
GNCV	19MAY94	1410	3.0	0.6	0.5	16.9	0.4	0.0	9.50	98.0
					1.0	16.9	0.4	0.0	9.48	97.8
					2.5	16.9	0.4	0.0	9.51	98.2
HGK	19MAY94	0900	5.0	0.7	0.5	16.4	0.5	0.0	9.69	98.8
					1.0	16.3	0.5	0.0	9.65	98.3
					2.0	16.3	0.5	0.0	9.70	98.9
					3.0	16.4	0.5	0.0	9.72	99.1
					4.5	16.3	0.5	0.0	9.70	98.9
R-64	21MAY94	0915	17.0	2.5	0.5	15.6	11.0	6.0	9.98	103.8
					2.0	15.5	11.0	6.0	10.10	104.9
					4.0	15.5	11.1	6.0	9.75	101.2
					6.0	15.6	11.4	6.2	9.69	100.9
					8.0	15.5	12.3	6.8	9.35	97.7
					10.0	15.7	16.1	9.2	7.82	83.2
					12.0	16.1	20.1	11.8	6.04	65.8
					14.0	16.1	23.3	13.9	5.04	55.6
16.5	15.8	24.2	14.5	4.01	44.2					

Numerical Water Quality and Contaminant Modeling (EL-22)
 Tidal Fresh Potomac River and Maryland Mainstem
 Water Profile: Vertical profile of water characteristics

STATION	DATE	TIME	TOTAL DEPTH (m)	SECCHI DEPTH (m)	SAMPLE DEPTH (m)	TEMP (C)	COND (mmho/cm)	SALIN (psu)	DO (mg/L)	DO SAT (%)
MDPT	13JUL94	1025	10.1	0.6	0.5	28.7	5.9	2.9	6.10	80.2
					2.0	28.5	5.9	3.0	5.85	76.7
					4.0	28.5	6.2	3.1	5.32	69.8
					6.0	28.5	6.4	3.2	5.25	68.9
					8.0	28.4	6.4	3.3	5.00	65.6
					9.5	28.4	6.6	3.4	4.98	65.3
GNCV	12JUL94	1404	3.0	0.4	0.5	29.8	0.6	0.0	10.23	134.8
					1.0	29.7	0.6	0.0	9.72	127.9
					2.0	29.6	0.6	0.0	9.86	129.7
HGNK	12JUL94	0955	5.4	0.6	0.5	29.5	0.6	0.0	8.12	106.5
					2.0	29.4	0.6	0.0	7.84	102.7
					3.0	29.4	0.6	0.0	7.94	104.1
					4.0	29.4	0.6	0.0	8.70	114.1
R-64	14JUL94	1030	16.5	2.4	0.5	28.3	15.1	8.6	8.40	113.2
					2.0	28.1	15.2	8.6	8.45	113.5
					4.0	28.0	15.6	8.9	7.83	105.2
					6.0	27.3	16.8	9.7	5.00	66.7
					8.0	25.7	21.0	12.4	1.32	17.4
					10.0	23.7	24.3	14.6	0.15	1.9
					12.0	23.3	26.2	15.9	0.12	1.5
					14.0	23.3	26.8	16.3	0.13	1.7
16.0	23.2	27.6	16.8	0.16	2.1					

Numerical Water Quality and Contaminant Modeling (EL-22)
 Tidal Fresh Potomac River and Maryland Mainstem
 Water Profile: Vertical profile of water characteristics

STATION	DATE	TIME	TOTAL DEPTH (m)	SECCHI DEPTH (m)	SAMPLE DEPTH (m)	TEMP (C)	COND (mmho/cm)	SALIN (psu)	DO (mg/L)	DO SAT (%)
MDPT	10AUG94	1000	10.5	0.5	0.5	26.7	6.5	3.3	6.74	85.7
					2.0	26.6	6.4	3.3	6.68	84.9
					4.0	26.7	7.0	3.6	6.30	80.3
					6.0	26.8	7.6	3.9	5.97	76.3
					8.0	26.8	7.8	4.1	5.96	76.3
					10.0	26.8	7.9	4.1	5.82	74.6
GNCV	9AUG94	1240	3.4	0.4	0.5	27.0	0.6	0.0	10.90	136.9
					1.0	27.0	0.6	0.0	10.80	135.5
					2.0	26.9	0.6	0.0	11.10	139.2
HGK	9AUG94	0923	4.0	0.5	0.5	26.5	0.7	0.0	8.13	101.1
					2.0	26.5	0.7	0.0	8.05	100.1
					3.0	26.4	0.7	0.0	8.35	103.7
R-64	11AUG94	1015	17.6	1.9	0.5	26.3	17.8	10.3	8.20	107.7
					2.0	26.3	17.8	10.3	8.07	106.0
					4.0	26.2	17.8	10.3	7.88	103.4
					6.0	26.2	18.2	10.6	6.41	84.2
					8.0	26.1	20.9	12.3	2.22	29.4
					10.0	25.9	26.0	15.7	0.10	1.3
					12.0	25.6	28.8	17.7	0.10	1.4
					14.0	25.5	30.3	18.7	0.10	1.4
16.0	25.3	31.7	19.7	0.10	1.4					

Numerical Water Quality and Contaminant Modeling (EL-22)
 Tidal Fresh Potomac River and Maryland Mainstem
 Water Profile: Vertical profile of water characteristics

STATION	DATE	TIME	TOTAL DEPTH (m)	SECCHI DEPTH (m)	SAMPLE DEPTH (m)	TEMP (C)	COND (mmho/cm)	SALIN (psu)	DO (mg/L)	DO SAT (%)
MDPT	14OCT94	0957	9.5	0.7	0.5	17.8	6.8	3.5	7.88	84.6
					2.0	17.9	7.1	3.6	7.80	83.9
					4.0	17.9	7.1	3.7	7.78	83.8
					6.0	17.9	7.7	4.0	7.76	83.8
					8.0	18.0	7.7	4.0	7.74	83.6
					9.0	18.1	8.7	4.6	7.75	84.2
GNCV	13OCT94	1210	3.3	0.4	0.5	17.6	0.6	0.0	10.12	105.9
					1.0	17.6	0.6	0.0	10.14	106.1
					1.5	17.5	0.6	0.0	10.25	107.0
					2.0	17.7	0.6	0.0	10.35	108.4
HGK	13OCT94	0855	5.5	0.7	0.5	17.5	0.7	0.0	8.42	88.0
					2.0	17.5	0.7	0.0	8.42	88.0
					4.0	17.5	0.7	0.0	8.49	88.8
					5.0	17.5	0.7	0.0	8.67	90.6
R-64	17OCT94	1436	16.0	2.3	0.5	17.6	24.0	14.4	8.53	97.4
					2.0	17.6	24.2	14.5	8.44	96.4
					4.0	17.4	24.9	15.0	8.43	96.2
					6.0	17.3	25.6	15.5	8.58	98.0
					8.0	17.4	25.8	15.6	8.26	94.5
					10.0	17.4	25.9	15.7	8.23	94.2
					12.0	17.6	26.2	15.9	8.00	92.0
					14.0	18.3	27.0	16.4	6.79	79.5
15.0	18.3	27.0	16.4	6.83	80.0					

Appendix B

Bottom Water Dissolved Nutrient Data Tables

Numerical Water Quality and Contaminant Modeling (EL-22)
 Tidal Fresh Potomac River and Maryland Mainstem
 Bottom Water Nutrients: Dissolved nutrient concentrations in bottom waters

STATION	DATE	TOTAL	SAMPLE	COFR													
		DEPTH (m)	DEPTH (m)	NH4 (μ M)	NO2+NO3 (μ M)	TDN (μ M)	DON (μ M)	DIP (μ M)	TDP (μ M)	DOP (μ M)	SI(OH)4 (μ M)	DOC (mg/L)	Fe (μ M)	Mn (μ M)	pH	SO4 (μ M)	TCO2 (μ M)
HGNK	19MAY94	5.0	4.5	10.6	101.4	125.0	13.0	0.23	0.46	0.23	95.0	S	-0.18	1.07	8.63	236.44	1387.5
GNCV	19MAY94	3.0	2.5	4.2	91.5	106.0	10.3	0.24	0.58	0.34	95.4	2.76	-0.36	0.98	7.81	24.92	1232.1
MDPT	20MAY94	10.0	9.5	5.2	92.7	106.0	8.1	0.85	1.08	0.23	26.6	2.72	0.72	0.62	7.84	334.94	1518.0
R 64	21MAY94	17.0	16.5	11.3	25.7	56.2	19.2	0.10	0.38	0.28	14.4	3.04	1.97	1.38	7.28	11065.86	1499.3
HGNK	12JUL94	5.4	4.0	5.8	91.2	125.0	28.0	0.56	1.07	0.51	2.6	4.00	0.00	0.03	7.67	366.17	HH
GNCV	12JUL94	3.0	2.0	0.4	47.7	72.6	24.5	0.69	1.39	0.70	0.7	4.04	0.00	0.02	8.62	313.00	1506.7
MDPT	13JUL94	10.1	9.5	5.4	26.9	50.3	18.0	1.71	1.85	0.14	63.3	2.93	0.00	0.16	7.34	2689.21	1285.2
R 64	14JUL94	16.5	16.0	26.0	0.1	48.4	22.3	1.45	1.81	0.36	39.1	2.03	0.00	0.00	7.22	7270.80	1687.7

Numerical Water Quality and Contaminant Modeling (EL-22)
 Tidal Fresh Potomac River and Maryland Mainstem
 Bottom Water Nutrients: Dissolved nutrient concentrations in bottom waters

STATION	DATE	TOTAL	SAMPLE	NH4 (μM)	NO2+NO3 (μM)	TDN (μM)	DON (μM)	COFR			SI(OH)4 (μM)	DOC (mg/L)	Fe (μM)	Mn (μM)	pH	SO4 (μM)	TCO2 (μM)
		DEPTH (m)	DEPTH (m)					DIP (μM)	TDP (μM)	DOP (μM)							
HGNK	9AUG94	4.0	3.0	4.7	109.2	137.6	23.7	0.37	0.75	0.38	10.9	3.63	0.00	0.53	7.61	375.35	1716
GNCV	9AUG94	3.4	2.0	0.4	59.8	79.6	19.4	0.62	0.92	0.30	3.0	3.82	0.00	0.49	8.37	398.22	1502
MDPT	10AUG94	10.5	10.0	3.7	9.1	34.0	21.2	1.85	2.17	0.32	49.8	3.17	0.00	0.62	7.24	3430.60	1259
R 64	11AUG94	17.6	16.0	26.0	0.2	49.8	23.6	2.50	2.88	0.38	44.5	1.94	5.19	0.58	7.18	15644.68	1880
HGNK	13OCT94	5.5	5.0	12.4	202.0	241.0	26.6	0.35	0.67	0.32	47.3	3.13	0.00	0.00	7.49	407.88	1932
GNCV	13OCT94	3.3	2.0	0.6	139.0	163.0	23.4	0.15	0.48	0.33	27.1	3.42	0.00	0.00	8.19	322.89	1645
MDPT	14OCT94	9.5	9.0	7.6	39.6	68.9	21.7	1.75	2.04	0.29	44.6	3.63	0.00	0.00	7.46	3625.45	1454
R 64	17OCT94	16.0	15.0	4.8	1.9	32.5	25.8	0.11	0.40	0.29	33.6	2.24	0.00	0.00	7.77	12516.7	1637

Appendix C

Sediment Samples: Solid Phase (0-10 cm) Data Tables; Dissolved Phase (0-10 cm) Data Tables

Depth (cm)	Sample ID	Parameter	Value	Unit	Notes
0.0	000.0
0.5	000.5
1.0	001.0
1.5	001.5
2.0	002.0
2.5	002.5
3.0	003.0
3.5	003.5
4.0	004.0
4.5	004.5
5.0	005.0
5.5	005.5
6.0	006.0
6.5	006.5
7.0	007.0
7.5	007.5
8.0	008.0
8.5	008.5
9.0	009.0
9.5	009.5

Numerical Water Quality and Contaminant Modeling (EL-22)
 Tidal Fresh Potomac River and Maryland Mainstem
 Surficial Sediments: Surficial sediment characteristics

STATION	DATE	SED FC %(wt)	SED PN %(wt)	SED FP %(wt)	SED CHLa TOTAL (mg/m2)	SED CHLa ACTIVE (mg/m2)
HGNK	19MAY94	4.18	0.34	0.087	13.4	7.1
GNCV	19MAY94	3.22	0.26	0.072	10.9	5.5
MDPT	20MAY94	2.58	0.29	0.093	4.6	1.2
R-64	21MAY94	2.88	0.36	0.132	15.5	4.6
HGNK	12JUL94	3.79	0.29	0.080	17.7	8.9
GNCV	12JUL94	3.83	0.26	0.080	13.9	7.0
MDPT	13JUL95	2.45	0.27	0.120	8.4	1.8
R-64	14JUL95	2.66	0.32	0.040	13.9	5.1
HGNK	9AUG95	3.59	0.30	0.100	12.9	5.5
GNCV	9AUG95	3.51	0.24	0.059	13.6	6.2
MDPT	10AUG95	2.38	0.26	0.097	9.2	2.5
R-64	11AUG95	2.72	0.33	0.050	13.9	5.4
HGNK	13OCT95	3.75	0.32	0.120	5.8	2.1
GNCV	13OCT95	3.00	0.23	0.080	8.5	3.0
MDPT	14OCT95	2.48	0.26	0.140	5.3	1.2
R-64	17OCT95	3.09	0.37	0.050	9.2	2.8

Numerical Water Quality and Contaminant Modeling (EL-22)
 Tidal Fresh Potomac River and Maryland Mainstem
 Pore Water: Nutrient concentrations in sediment pore water

STATION	DATE	AA VIAL #	NH4 (μM)	NO2+NO3 (μM)	DIP (μM)	SI(OH)4 (μM)	DOC VIAL #	DOC (mg/L)	ALK (mg CaCO3/L)	DON/DOP VIAL #	DON ($\mu\text{g/L}$)	DOP ($\mu\text{g/L}$)	pH
HGNK	19MAY94	211	2126	0.53	0.09	213.7	R39	24.2	1360.0	39	-40.53	-0.05	7.27
GNCV	19MAY94	212	1283	0.33	0.14	276.8	R44	25.0	1650.0	44	90.67	-0.09	7.31
MDPT	20MAY94	234	172	0.48	12.80	220.5	R66	17.7	250.8	66	275.32	2.90	7.47
R-64	21MAY94	235	356	1.81	33.40	455.9	R88	6.0	475.8	88	32.59	46.90	6.97
HGNK	12JUL94	211	1906	0.33	0.29	379.6	G19	21.4	1079.2	Y43	-301.33	0.51	6.87
GNCV	12JUL94	212	1542	0.25	2.05	366.4	G21	18.9	1175.0	Y44	-99.25	-1.15	6.91
MDPT	13JUL94	402	522	6.08	0.90	329.4	G43	10.1	266.7	Y66	26.92	12.70	7.19
R-64	14JUL94	98	243	110.00	0.34	653.4	G65	14.4	629.2	Y88	78.30	94.06	7.30
HGNK	9AUG94	208	1834	2.71	0.32	374.0	49	18.0	1106.7	36	-177.71	-0.13	6.65
GNCV	9AUG94	203	1326	0.28	0.27	429.0	44	15.1	730.0	31	20.72	0.39	6.75
MDPT	10AUG94	234	416	0.31	4.41	280.0	79	6.8	295.0	66	25.69	1.73	6.81
R-64	11AUG94	106	802	1.40	146.00	817.0	16	14.6	1120.0	88	-257.40	26.00	7.21
HGNK	13OCT94	209	3780	0.28	0.39	385.0	36	23.9	1287.5	36	-765.28	0.55	6.75
GNCV	13OCT94	204	1930	1.52	0.22	365.0	35	18.7	1184.2	35	-247.52	-0.20	6.83
MDPT	14OCT94	235	1380	0.46	5.09	222.0	66	8.9	335.0	66	-855.46	0.54	7.04
R-64	17OCT94	236	495	0.52	193.00	704.0	88	22.8	1580.0	88	307.48	64.00	7.39

Numerical Water Quality and Contaminant Modeling (EL-22)
 Tidal Fresh Potomac River and Maryland Mainstem
 Hydrogen Sulfide: Vertical profile of free hydrogen sulfide in sediment

STATION	MONTH	SEDIMENT DEPTH (cm)	SIDE A* (μM)	SIDE B* (μM)	AVG H ₂ S (μM)	STANDARD ERROR
HGK	MAY	1	1.15	1.91	1.53	0.38
		3	0.18	1.49	0.83	0.65
		5	0.51	-0.01	0.25	0.26
		7	0.93	0.65	0.79	0.14
		9	0.94	0.74	0.84	0.10
GNCV	MAY	1	0.32	0.58	0.45	0.13
		3	0.46	0.22	0.34	0.12
		5	-0.01	-0.01	-0.01	0.00
		7	-0.01	-0.01	-0.01	0.00
		9	-0.25	-0.01	-0.13	0.12
MDPT	MAY	1	0.69	1.29	0.99	0.30
		3	2.42	1.96	2.19	0.23
		5	2.99	1.76	2.38	0.61
		7	2.98	2.20	2.59	0.39
		9	4.09	2.00	3.04	1.05
R 64	MAY	1	0.17	0.45	0.31	0.14
		3	12.58	7.99	10.29	2.30
		5	227.17	181.91	204.54	13.10
		7	508.31	662.67	585.49	52.82
		9	923.29	1117.73	1020.51	73.98

*Note: A core was divided into two halves. Samples were taken from each half, side A and B respectively.

Numerical Water Quality and Contaminant Modeling (EL-22)
 Tidal Fresh Potomac River and Maryland Mainstem
 Hydrogen Sulfide: Vertical profile of free hydrogen sulfide in sediment

STATION	MONTH	SEDIMENT		SIDE B* (μ M)	AVG H2S (μ M)	STANDARD ERROR
		DEPTH (cm)	SIDE A* (μ M)			
HGK	JULY	1	1.04	0.95	0.99	0.04
		3	1.50	0.37	0.94	0.57
		5	0.65	0.27	0.46	0.19
		7	0.75	0.47	0.61	0.14
		9	0.56	0.56	0.66	0.00
GNCV	JULY	1	0.46	0.56	0.51	0.05
		3	0.36	0.65	0.51	0.15
		5	0.58	1.03	0.80	0.23
		7	0.58	0.84	0.71	0.13
		9	0.34	0.86	0.60	0.26
MDPT	JULY	1	0.22	0.56	0.39	0.17
		3	9.57	1.97	5.77	3.80
		5	0.11	0.75	0.43	0.32
		7	0.34	0.86	0.60	0.26
		9	3.71	8.65	6.18	2.47
R 64	JULY	1	301.11	403.28	352.20	51.08
		3	496.26	431.39	463.82	32.40
		5	448.84	334.56	391.70	57.10
		7	437.52	299.01	368.27	69.20
		9	565.02	837.93	701.48	136.40

*Note: A core was divided into two halves. Samples were taken from each half, side A and B respectively.

Numerical Water Quality and Contaminant Modeling (EL-22)
 Tidal Fresh Potomac River and Maryland Mainstem
 Hydrogen Sulfide: Vertical profile of free hydrogen sulfide in sediment

STATION	MONTH	SEDIMENT		SIDE A* (μM)	SIDE B* (μM)	AVG H ₂ S (μM)	STANDARD ERROR
		DEPTH (cm)					
HGK	AUGUST	1		1.03	1.40	1.22	0.19
		3		0.74	0.88	0.81	0.07
		5		0.50	0.64	0.57	0.07
		7		0.50	0.73	0.61	0.11
		9		0.79	0.58	0.69	0.11
GNCV	AUGUST	1		0.42	0.80	0.61	0.19
		3		0.72	0.58	0.65	0.07
		5		0.66	0.51	0.59	0.07
		7		0.65	0.52	0.59	0.06
		9		0.88	0.35	0.61	0.27
MDPT	AUGUST	1		0.50	0.42	0.46	0.04
		3		0.42	0.50	0.46	0.04
		5		0.35	0.58	0.47	0.11
		7		0.58	0.43	0.50	0.08
		9		0.43	1.19	0.81	0.38
R 64	AUGUST	1		1151.03	1025.31	1088.17	45.87
		3		1901.11	2021.84	1961.47	99.67
		5		1647.60	2028.68	1838.14	133.01
		7		1913.97	2273.24	2093.60	104.48
		9		1895.12	2054.50	1974.81	54.29

*Note: A core was divided into two halves. Samples were taken from each half, side A and B respectively.

Numerical Water Quality and Contaminant Modeling (EL-22)
 Tidal Fresh Potomac River and Maryland Mainstem
 Hydrogen Sulfide: Vertical profile of free hydrogen sulfide in sediment

STATION	MONTH	SEDIMENT DEPTH (cm)	SIDE A* (μM)	SIDE B* (μM)	AVG H ₂ S (μM)	STANDARD ERROR
HGNIK	OCTOBER	1	1.15	1.54	1.34	0.19
		3	0.85	0.94	0.90	0.04
		5	0.85	0.85	0.85	0.00
		7	1.10	0.93	1.02	0.08
		9	1.50	0.52	1.01	0.49
GNCV	OCTOBER	1	0.69	0.69	0.69	0.00
		3	0.77	0.86	0.81	0.04
		5	0.68	0.94	0.81	0.13
		7	0.60	0.77	0.69	0.08
		9	0.78	0.94	0.86	0.08
MDPT	OCTOBER	1	0.92	0.93	0.92	0.00
		3	0.92	1.10	1.01	0.09
		5	1.01	1.74	1.38	0.37
		7	1.18	0.93	1.05	0.13
		9	1.02	1.18	1.10	0.08
R 64	OCTOBER	1	1315.65	2661.12	1988.38	409.18
		3	2000.24	4655.34	3327.79	797.79
		5	4559.36	5302.87	4931.11	1067.89
		7	3968.64	5342.62	4655.63	753.60
		9	3156.96	3786.74	3471.85	269.08

*Note: A core was divided into halves. Samples were taken from each half, side A and B respectively.

Numerical Water Quality and Contaminant Modeling (EL-22)
 Tidal Fresh Potomac River and Maryland Mainstem
 Methane: Vertical profile of methane in sediments

STATION	MONTH	DEPTH (cm)	SIDE A* (mM/Lws)**	SIDE B* (mM/Lws)**	AVG METHANE (mM/Lws)**	STANDARD DEVIATION	METHANE (mM/m2)	AVERAGE POROSITY	STANDARD DEVIATION
HGK	MAY	1	0.502	0.092	0.297	0.205	5.95	3.475	2.475
		3	1.072	0.758	0.915	0.157	18.30	10.650	7.650
		5	1.002	1.533	1.267	0.266	25.35	15.175	10.175
		7	1.471	1.206	1.339	0.132	26.77	16.885	9.885
		9	1.012	1.070	1.041	0.029	20.82	14.910	5.910
GNCV	MAY	1	0.725	0.604	0.665	0.061	13.29	7.145	6.145
		3	1.153	1.203	1.178	0.025	23.55	13.275	10.275
		5	1.174	1.352	1.263	0.089	25.27	15.135	10.135
		7	1.373	1.724	1.549	0.175	30.98	18.990	11.990
		9	1.132	1.644	1.388	0.256	27.77	18.385	9.385
MDPT	MAY	1	0.020	0.010	0.015	0.005	0.31	0.655	0.345
		3	0.033	0.016	0.024	0.008	0.40	1.700	1.300
		5	0.087	0.073	0.080	0.007	1.50	3.250	1.750
		7	0.161	0.197	0.179	0.018	3.50	5.250	1.750
		9	0.368	0.314	0.341	0.027	6.80	7.900	1.100
R 64	MAY	1	0.004	0.008	0.006	0.002	0.13	0.565	0.435
		3	0.009	0.013	0.011	0.002	0.22	1.610	1.390
		5	0.020	0.020	0.020	0.000	0.39	2.695	2.305
		7	0.025	0.033	0.029	0.004	0.58	3.790	3.210
		9	0.037	0.037	0.037	0.000	0.74	4.870	4.130

*Note: A core was divided into two halves. Samples were taken from each half, side A and B respectively.

**Note: Lws = liter wet sediment

Numerical Water Quality and Contaminant Modeling (EL-22)
 Tidal Fresh Potomac River and Maryland Mainstem
 Methane: Vertical profile of methane in sediments

STATION	MONTH	DEPTH (cm)	SIDE A* (mM/Lws)**	SIDE B* (mM/Lws)**	AVG METHANE (mM/Lws)**	STANDARD DEVIATION	METHANE (mM/m2)	AVERAGE POROSITY	STANDARD DEVIATION
HGK	JULY	1	1.345	S	1.345	0.000	26.90	13.950	12.950
		3	1.095	1.139	1.117	0.022	22.34	12.670	9.670
		5	1.321	0.999	1.160	0.161	23.20	14.100	9.100
		7	1.355	1.096	1.226	0.129	24.51	15.755	8.755
		9	1.165	1.397	1.281	0.116	25.62	17.310	8.310
GNCV	JULY	1	1.347	2.129	1.738	0.391	34.77	17.885	16.885
		3	1.192	1.175	1.184	0.008	23.67	13.335	10.335
		5	4.424	2.162	3.293	1.131	65.86	35.430	30.430
		7	1.222	1.491	1.357	0.135	27.13	17.065	10.065
		9	1.137	1.164	1.151	0.013	23.02	16.010	7.010
MDPT	JULY	1	0.023	0.017	0.020	0.003	0.39	0.695	0.305
		3	0.017	0.051	0.034	0.017	0.68	1.840	1.160
		5	0.042	0.081	0.061	0.019	1.23	3.115	1.885
		7	0.074	0.241	0.158	0.083	3.15	5.075	1.925
		9	0.429	0.569	0.499	0.070	9.98	9.490	0.490
R 64	JULY	1	0.004	0.004	0.004	0.000	0.08	0.540	0.460
		3	0.006	0.006	0.006	0.000	0.12	1.560	1.440
		5	0.008	0.007	0.008	0.000	0.15	2.575	2.425
		7	0.010	0.008	0.009	0.001	0.18	3.590	3.410
		9	0.012	0.011	0.012	0.000	0.23	4.615	4.385

*Note: A core was divided into two halves. Samples were taken from each half, side A and B respectively.

**Note: Lws = liter wet sediment

Numerical Water Quality and Contaminant Modeling (EL-22)
 Tidal Fresh Potomac River and Maryland Mainstem
 Methane: Vertical profile of methane in sediments

STATION	MONTH	DEPTH (cm)	SIDE A* (mM/Lws)**	SIDE B* (mM/Lws)**	AVG	STANDARD DEVIATION	METHANE (mM/m ²)	AVERAGE POROSITY	STANDARD DEVIATION
					METHANE (mM/Lws)**				
HGNK	AUGUST	1	0.506	1.868	1.187	0.681	23.74	12.370	11.370
		3	1.350	1.374	1.362	0.012	27.24	15.120	12.120
		5	2.135	1.796	1.965	0.169	39.30	22.150	17.150
		7	2.137	1.710	1.923	0.214	38.47	22.735	15.735
		9	1.104	0.965	1.035	0.069	20.69	14.845	5.845
GNCV	AUGUST	1	1.311	0.903	1.107	0.204	22.14	11.570	10.570
		3	1.191	0.902	1.046	0.145	20.93	11.965	8.965
		5	1.009	1.050	1.030	0.021	20.59	12.795	7.795
		7	1.099	1.105	1.102	0.003	22.04	14.520	7.520
		9	1.135	2.190	1.662	0.527	33.25	21.125	12.125
MDPT	AUGUST	1	0.008	0.012	0.010	0.002	0.20	0.600	0.400
		3	0.016	0.037	0.027	0.011	0.53	1.765	1.235
		5	0.043	0.045	0.044	0.001	0.88	2.940	2.060
		7	0.047	0.127	0.087	0.040	1.73	4.365	2.635
		9	0.119	0.286	0.203	0.084	4.05	6.525	2.475
R 64	AUGUST	1	0.015	0.011	0.013	0.002	0.25	0.625	0.375
		3	0.028	0.027	0.028	0.001	0.55	1.775	1.225
		5	0.045	0.044	0.045	0.001	0.89	2.945	2.055
		7	0.051	0.068	0.059	0.009	1.19	4.095	2.905
		9	0.083	0.089	0.086	0.003	1.72	5.360	3.640

*Note: A core was divided into two halves. Samples were taken from each half, side A and B respectively.

**Note: Lws = liter wet sediment

Numerical Water Quality and Contaminant Modeling (EL-22)
Tidal Fresh Potomac River and Maryland Mainstem
Methane: Vertical profile of methane in sediments

STATION	MONTH	DEPTH (cm)	SIDE A* (mM/Lws)**	SIDE B* (mM/Lws)**	AVG	STANDARD DEVIATION	METHANE (mM/m ²)	AVERAGE POROSITY	STANDARD DEVIATION
					METHANE (mM/Lws)**				
HGNK	OCTOBER	1	1.649	1.535	1.592	0.057	31.83	16.415	15.415
		3	2.971	1.626	2.299	0.673	45.98	24.490	21.490
		5	2.410	2.717	2.563	0.153	51.27	28.135	23.135
		7	2.115	1.606	1.860	0.255	37.20	22.100	15.100
		9	2.430	1.144	1.787	0.643	35.74	22.370	13.370
GNCV	OCTOBER	1	1.585	0.694	1.140	0.445	22.79	11.895	10.895
		3	1.323	1.502	1.413	0.090	28.26	15.630	12.630
		5	1.307	1.276	1.291	0.016	25.83	15.415	10.415
		7	1.898	1.933	1.915	0.018	38.30	22.650	15.650
		9	3.239	2.792	3.016	0.223	60.31	34.655	25.655
MDPT	OCTOBER	1	0.027	0.032	0.030	0.002	0.59	0.795	0.205
		3	0.379	0.011	0.195	0.184	3.90	3.450	0.450
		5	0.054	0.285	0.169	0.116	3.39	4.195	0.805
		7	0.020	0.048	0.034	0.014	0.68	3.840	3.160
		9	0.090	0.131	0.111	0.020	2.21	5.605	3.395
R 64	OCTOBER	1	0.020	0.025	0.022	0.002	0.45	0.725	0.275
		3	0.033	0.031	0.032	0.001	0.64	1.820	1.180
		5	0.038	0.036	0.037	0.001	0.74	2.870	2.130
		7	0.038	0.036	0.037	0.001	0.74	3.870	3.130
		9	0.036	0.035	0.036	0.001	0.71	4.855	4.145

*Note: A core was divided into two halves. Samples were taken from each half, side A and B respectively.

**Note: Lws = liter wet sediment

Appendix D Incubation Core Nutrient Concentration Data Tables

Numerical Water Quality and Contaminant Modeling (EL-22)
 Tidal Fresh Potomac River and Maryland Mainstem
 Core Data: Dissolved nutrient and oxygen concentrations in sediment - water flux chambers

STATION	DATE	CORE NO	TIME OF SAMPLE (hr min)	TIME DELTA (min)	TIME SUM (min)	DO (mg/L)	AA VIAL NO	NH4 (μ M)	NO2+NO3 (μ M)	DIP (μ M)
HGNK	19MAY94	B	10 25	0	0	9.33	169	13.4	101.0	0.21
			11 25	60	60	9.30	174	13.0	101.5	0.27
			12 25	60	120	9.28	178	11.7	101.6	0.23
			13 27	62	182	9.26	182	12.4	101.8	0.22
			14 25	58	240	9.23	186	12.2	101.5	0.22
			1 10 25	0	0	8.94	170	17.6	100.1	0.26
		1 11 25	60	60	8.47	175	21.7	99.1	0.29	
		1 12 25	60	120	8.07	179	25.0	97.3	0.29	
		1 13 27	62	182	7.62	183	29.8	96.2	0.29	
		1 14 25	58	240	7.20	187	36.7	94.7	0.29	
		2 10 25	0	0	8.95	171	13.3	99.9	0.27	
		2 11 25	60	60	8.44	176	16.0	99.0	0.30	
		2 12 25	60	120	7.95	180	19.0	97.0	0.33	
		2 13 27	62	182	7.43	184	22.4	94.8	0.33	
		2 14 25	58	240	7.00	188	23.5	93.8	0.35	
		3 10 25	0	0	8.87	172	13.6	99.3	0.26	
		3 11 25	60	60	8.42	177	14.5	95.3	0.32	
		3 12 25	60	120	7.98	181	16.9	93.5	0.30	
		3 13 27	62	182	7.56	185	18.4	90.0	0.31	
		3 14 25	58	240	7.26	189	20.3	85.9	0.31	

HGK May 1994 continued

SI(OH) ₄ (μ M)	DOC (mg/L)	TCO ₂ (μ M)	DON (μ g/L)	TDN (μ g/L)	DOP (μ g/L)	TDP (μ g/L)	pH	Fe (μ M)	Mn (μ M)
94.3	2.56	1388.7	11.6	126.0	0.28	0.49	7.84	0.72	1.16
97.3	2.36	HH	12.5	127.0	0.24	0.51	7.98	0.18	1.09
94.6	2.44	HH	11.7	125.0	0.32	0.55	8.11	0.54	1.02
100.5	2.43	HH	11.8	126.0	0.31	0.53	8.13	0.18	0.96
99.0	2.40	1381.8	14.3	128.0	0.30	0.52	7.99	0.00	0.91
93.5	2.51	1504.4	12.3	130.0	0.24	0.50	7.90	0.90	2.42
94.1	2.54	1559.3	20.2	141.0	0.24	0.53	7.88	0.72	3.57
99.8	2.58	HH	23.7	146.0	0.27	0.56	7.85	6.98	4.31
105.4	2.58	1690.6	21.0	147.0	0.30	0.59	7.76	1.43	5.22
109.1	S	1703.5	20.6	152.0	0.25	0.54	7.72	2.15	6.26
91.2	2.49	1432.3	12.8	126.0	0.25	0.52	7.96	0.18	1.89
96.5	2.89	1603.4	12.0	127.0	0.25	0.55	7.96	0.36	2.35
99.9	2.53	HH	12.0	128.0	0.26	0.59	7.94	0.72	2.91
103.2	2.54	1640.8	11.8	129.0	0.32	0.65	7.89	0.54	3.60
111.1	S	1620.9	15.7	133.0	0.24	0.59	7.79	0.18	4.10
98.9	2.51	1423.2	12.5	126.0	0.23	0.49	7.97	0.36	1.93
111.4	2.51	1522.7	13.2	123.0	0.25	0.57	7.98	0.36	2.57
119.6	2.48	HH	12.6	123.0	0.27	0.57	7.94	0.90	3.09
133.9	2.50	1599.8	11.6	120.0	0.25	0.56	7.97	3.94	3.55
147.8	2.52	1729.0	11.8	118.0	0.22	0.53	7.89	0.00	4.04

Numerical Water Quality and Contaminant Modeling (EL-22)
 Tidal Fresh Potomac River and Maryland Mainstem
 Core Data: Dissolved nutrient and oxygen concentrations in sediment - water flux chambers

STATION	DATE	CORE NO	TIME OF SAMPLE		TIME DELTA (min)	TIME SUM (min)	DO (mg/L)	AA VIAL NO	NH4 (μ M)	NO2+NO3 (μ M)	DIP (μ M)
			(hr)	(min)							
GNCV	19MAY94	B	15	35	0	0	9.09	191	4.2	91.2	0.23
			16	35	60	60	9.03	195	4.0	91.2	0.26
			17	35	60	120	8.99	199	4.2	91.2	0.27
			18	35	60	180	8.96	203	4.1	90.9	0.25
			19	35	60	240	8.93	207	4.0	91.0	0.24
		1	15	35	0	0	8.67	192	7.6	90.5	0.27
			16	35	60	60	8.08	196	10.3	88.8	0.31
			17	35	60	120	7.60	200	11.9	87.5	0.34
			18	35	60	180	7.17	204	12.8	86.6	0.32
			19	35	60	240	6.79	208	14.5	85.8	0.34
		2	15	35	0	0	8.71	193	6.6	90.0	0.26
			16	35	60	60	8.10	197	8.7	88.5	0.25
			17	35	60	120	7.59	201	10.6	87.4	0.32
			18	35	60	180	7.12	205	13.7	86.3	0.35
			19	35	60	240	6.72	209	15.3	85.8	0.34
		3	15	35	0	0	8.76	194	5.0	90.3	0.24
			16	35	60	60	8.23	198	6.7	89.4	0.26
			17	35	60	120	7.92	202	8.6	88.3	0.30
			18	35	60	180	7.53	206	9.8	87.3	0.29
			19	35	60	240	7.21	210	10.8	86.6	0.30

GNCV MAY 1994 continued

SI(OH) ₄ (μ M)	DOC (mg/L)	TCO ₂ (μ M)	DON (μ g/L)	TDN (μ g/L)	DOP (μ g/L)	TDP (μ g/L)	pH	Fe (μ M)	Mn (μ M)
102.4	S	1229.0	11.6	107	0.44	0.67	7.97	-0.36	0.49
103.1	2.66	HH	13.8	109	0.37	0.63	8.01	-0.18	0.47
99.9	2.61	HH	9.6	105	0.34	0.61	8.09	0.54	0.46
106.4	2.64	HH	13.0	108	0.40	0.65	8.10	-0.18	0.42
104.7	2.75	1238.0	12.0	107	0.35	0.59	8.04	-0.36	0.42
102.1	2.71	1330.8	10.9	109	0.38	0.65	7.94	-0.18	1.98
105.3	2.80	1417.0	11.9	111	0.33	0.64	7.86	0	2.73
107.1	2.78	HH	12.6	112	0.37	0.71	7.86	-0.18	2.89
108.9	2.75	1502.8	12.6	112	0.36	0.68	7.84	0	2.99
110.3	S	1543.6	11.7	112	0.34	0.68	7.80	-0.18	2.86
102.8	2.74	1295.0	11.4	108	0.37	0.63	8.01	-0.18	1.57
105.3	2.76	1368.0	11.8	109	0.40	0.65	7.91	-0.18	2.33
103.0	2.74	HH	12.0	110	0.37	0.69	7.88	-0.18	2.80
106.4	S	1473.3	S	S	S	S	7.85	-0.18	3.22
103.5	2.94	1492.9	9.9	111	0.34	0.68	7.82	-0.18	3.48
102.6	2.62	1285.9	13.7	109	0.40	0.64	8.05	1.25	0.96
102.4	2.83	1350.6	11.9	108	0.39	0.65	7.95	2.33	1.31
102.7	2.87	HH	12.1	109	0.34	0.64	7.94	0.18	1.57
105.0	2.73	1359.0	13.9	111	0.38	0.67	7.96	-0.36	1.75
105.2	2.90	1378.2	11.6	109	0.33	0.63	7.85	-0.36	1.86

Numerical Water Quality and Contaminant Modeling (EL-22)

Tidal Fresh Potomac River and Maryland Mainstem

Core Data: Dissolved nutrient and oxygen concentrations in sediment - water flux chambers

STATION	DATE	CORE NO	TIME OF SAMPLE		TIME DELTA (min)	TIME SUM (min)	DO (mg/L)	AA VIAL NO	NH4 (μ M)	NO2+NO3 (μ M)	DIP (μ M)
			(hr)	(min)							
MDPT	20MAY94	B	10	35	0	0	8.03	214	5.1	92.7	0.85
			11	35	60	60	7.97	218	5.0	92.6	0.85
			12	35	60	120	7.97	222	4.9	92.8	0.86
			13	45	70	190	7.98	226	5.0	92.8	0.84
			14	47	62	252	7.95	230	5.3	93.3	0.84
		1	10	35	0	0	7.88	215	5.5	92.1	0.91
			11	35	60	60	7.50	219	6.0	91.4	0.95
			12	35	60	120	7.21	223	6.4	90.3	0.95
			13	45	70	190	6.83	227	7.1	89.4	0.98
			14	47	62	252	6.62	231	6.9	88.2	0.94
		2	10	35	0	0	7.72	216	6.0	91.6	0.94
			11	35	60	60	7.11	220	6.9	89.6	0.95
			12	35	60	120	6.58	224	7.5	87.7	0.96
			13	45	70	190	5.95	228	8.3	84.5	1.01
			14	47	62	252	5.57	232	9.5	84.1	1.05
		3	10	35	0	0	7.74	217	5.7	92.0	0.90
			11	35	60	60	7.21	221	6.4	89.3	0.88
			12	35	60	120	6.76	225	7.1	87.8	0.96
			13	45	70	190	6.26	229	7.9	84.8	0.97
14	47		62	252	5.93	233	8.3	83.5	1.01		

MDPT MAY 1994 continued

SI(OH) ₄ (μ M)	DOC (mg/L)	TCO ₂ (μ M)	DON (μ g/L)	TDN (μ g/L)	DOP (μ g/L)	TDP (μ g/L)	pH	Fe (μ M)	Mn (μ M)
29.7	2.77	1517.1	10.2	108	0.37	1.22	7.94	0.54	0.47
28.6	2.66	HH	5.4	103	0.18	1.03	7.82	-0.18	0.46
27.6	2.62	HH	S	S	S	S	7.86	0.54	0.47
27.8	2.75	HH	9.2	107	0.29	1.13	7.81	-0.18	0.46
28.1	2.76	1519.6	10.4	109	0.40	1.24	7.81	-0.18	0.46
30.1	2.95	1523.5	6.4	104	0.17	1.08	7.95	0.18	0.95
34.2	2.68	1533.8	7.6	105	0.20	1.15	7.87	0.18	1.26
36.8	2.73	HH	8.3	105	0.21	1.16	7.86	0.54	1.55
38.2	2.69	1550.8	7.5	104	0.20	1.18	7.79	0.90	1.78
45.2	2.88	1569.9	10.9	106	0.34	1.28	7.83	0.18	1.84
29.2	2.74	1523.6	9.4	107	0.28	1.22	7.95	-0.36	0.93
31.8	2.69	1534.8	7.5	104	0.27	1.22	7.84	0.36	1.27
32.6	3.01	HH	8.8	104	0.22	1.18	7.81	-0.18	1.55
32.7	2.73	1551.1	8.2	101	0.17	1.18	7.72	0.18	1.98
34.3	2.78	1561.1	6.4	100	0.20	1.25	7.75	0.00	2.11
30.2	2.74	1508.3	7.3	105	0.22	1.12	7.94	0.18	0.82
31.2	2.67	1531.4	8.3	104	0.31	1.19	7.88	0.00	1.16
32.4	2.75	HH	9.1	104	0.27	1.23	7.86	0.18	1.44
35.0	2.93	1548.0	9.3	102	0.28	1.25	7.79	0.18	1.78
37.1	2.81	1560.8	8.2	100	0.32	1.33	7.78	0.00	1.97

Numerical Water Quality and Contaminant Modeling (EL-22)
 Tidal Fresh Potomac River and Maryland Mainstem
 Core Data: Dissolved nutrient and oxygen concentrations in sediment - water flux chambers

STATION	DATE	CORE NO	TIME OF SAMPLE		TIME DELTA (min)	TIME SUM (min)	DO (mg/L)	AA VIAL NO	NH4 (μ M)	NO2+NO3 (μ M)	DIP (μ M)
			(hr)	(min)							
R-64	21MAY94	B	11	10	0	0	4.31	128	11.6	25.6	0.12
			12	10	60	60	4.27	132	11.4	25.7	0.12
			13	10	60	120	4.27	136	11.6	25.7	0.13
			14	10	60	180	4.27	141	11.9	25.7	0.13
			15	10	60	240	4.22	149	11.6	25.7	0.12
		1	11	10	0	0	4.07	129	13.1	25.2	0.22
			12	10	60	60	3.79	133	15.2	24.5	0.26
			13	10	60	120	3.56	137	17.4	24.1	0.29
			14	10	60	180	3.36	142	18.7	23.0	0.32
			15	10	60	240	3.18	150	20.2	23.0	0.32
		2	11	10	0	0	4.15	130	13.0	25.2	0.23
			12	10	60	60	3.83	134	14.4	24.4	0.25
			13	10	60	120	3.57	138	15.9	23.6	0.28
			14	10	60	180	3.34	143	17.1	23.4	0.33
			15	10	60	240	3.16	151	18.3	22.4	0.31
		3	11	10	0	0	4.18	131	12.2	25.3	0.21
			12	10	60	60	3.89	135	13.6	24.7	0.28
			13	10	60	120	3.62	139	14.8	23.7	0.31
			14	10	60	180	3.45	144	15.8	22.9	0.32
			15	10	60	240	SS	152	16.9	22.6	0.33

R 64 MAY 1994 continued

Si(OH) ₄ (μ M)	DOC (mg/L)	TCO ₂ (μ M)	DON (μ g/L)	TDN (μ g/L)	DOP (μ g/L)	TDP (μ g/L)	pH	Fe (μ M)	Mn (μ M)
14.6	2.15	1498.0	15.1	52.3	0.10	0.22	7.30	1.79	1.38
14.7	2.19	1497.2	17.3	54.4	0.23	0.35	7.42	1.61	1.47
15.0	2.11	1497.3	15.1	52.4	0.15	0.28	7.35	1.61	1.46
14.7	2.09	1497.2	16.1	53.7	0.18	0.31	7.29	1.61	1.42
14.6	2.14	1494.2	15.5	52.8	0.20	0.32	7.30	2.15	1.49
16.8	2.18	1513.0	17.2	55.5	0.12	0.34	7.34	1.79	1.71
19.4	2.16	1531.7	19.5	59.2	0.23	0.49	7.38	1.97	1.86
21.6	2.14	1553.0	17.7	59.2	0.20	0.49	7.31	1.97	2.06
23.7	2.17	1565.1	17.1	58.8	0.21	0.53	7.26	1.79	2.13
25.2	2.15	1578.3	19.9	63.1	0.26	0.58	7.24	1.97	2.17
16.9	2.23	1505.0	18.6	56.8	0.26	0.49	7.31	2.15	1.64
19.0	2.17	1521.6	17.1	55.9	0.18	0.43	7.40	1.97	1.67
21.0	2.16	1533.3	16.8	56.3	0.17	0.45	7.34	1.97	1.78
23.2	2.15	1540.3	16.4	56.9	0.17	0.50	7.32	2.86	1.97
24.8	2.18	1554.5	17.4	58.1	0.19	0.50	7.30	1.97	
15.8	2.13	1505.6	17.1	54.6	0.15	0.36	7.39	1.97	1.64
18.4	2.29	1526.1	17.7	56.0	0.19	0.47	7.38	1.97	1.66
20.2	2.14	1533.2	17.1	55.6	0.17	0.48	7.35	2.15	1.66
22.6	2.16	1548.0	17.8	56.5	0.18	0.50	7.33	2.33	1.80
24.9	2.12	1556.9	23.0	62.5	0.26	0.59	7.28	3.22	1.86

Numerical Water Quality and Contaminant Modeling (EL-22)

Tidal Fresh Potomac River and Maryland Mainstem

Core Data: Dissolved nutrient and oxygen concentrations in sediment - water flux chambers

STATION	DATE	CORE NO	TIME OF SAMPLE		TIME DELTA (min)	TIME SUM (min)	DO (mg/L)	AA VIAL NO	NH4 (μM)	NO2+NO3 (μM)	DIP (μM)
			(hr)	(min)							
HGNK	12JUL94	B	11	15	0	0	7.10	170	4.6	90.50	0.41
			12	20	65	65	7.02	174	4.7	89.80	0.53
			13	20	60	125	6.95	178	4.6	89.20	0.60
			14	20	60	185	6.88	183	4.8	89.10	0.36
			15	45	85	270	6.75	187	4.7	87.90	0.47
		1	11	15	0	0	6.65	171	10.0	89.00	0.62
			12	20	65	65	5.74	175	17.0	86.20	0.51
			13	20	60	125	4.99	179	21.8	83.30	0.62
			14	20	60	185	4.30	184	27.0	80.40	0.64
			15	45	85	270	3.40	188	34.7	76.30	1.28
		2	11	15	0	0	6.79	172	15.8	89.30	0.38
			12	20	65	65	5.83	176	29.6	87.00	0.45
			13	20	60	125	5.01	180	41.0	85.10	0.46
			14	20	60	185	4.32	185	45.9	83.00	0.50
			15	45	85	270	3.45	189	56.8	79.70	0.73
3	11	15	0	0	6.87	173	8.2	88.60	0.62		
	12	20	65	65	5.92	177	13.9	86.30	0.47		
	13	20	60	125	5.10	181	18.9	84.40	0.66		
	14	20	60	185	4.36	186	23.1	82.30	0.45		
	15	45	85	270	3.41	190	27.9	79.30	0.80		

HGNK JULY 1994 continued

SI(OH) ₄ (μM)	DOC (mg/L)	TCO ₂ (μM)	DON (μg/L)	TDN (μg/L)	DOP (μg/L)	TDP (μg/L)	pH	Fe (μM)	Mn (μM)
5.6	3.86	1679.3	24.9	120.0	0.60	1.01	7.82	0.90	0.47
8.4	4.02	HH	27.5	122.0	0.54	1.07	7.76	0.36	0.27
12.4	3.88	HH	19.6	113.4	0.47	1.07	7.63	0.36	0.25
16.2	3.91	HH	23.1	117.0	0.73	1.09	7.77	0.18	0.27
22.0	3.86	1762.3	30.4	123.0	0.61	1.08	7.63	0.18	0.25
4.3	3.92	1771.6	28.0	127.0	0.59	1.21	7.73	0.00	1.16
7.6	4.04	1816.8	26.8	130.0	0.80	1.31	7.62	0.18	2.06
10.8	4.19	HH	25.9	131.0	0.91	1.53	7.50	0.00	2.77
13.5	4.05	1956.4	30.6	138.0	0.94	1.58	7.50	0.18	3.57
16.8	4.06	2007.7	22.0	133.0	0.35	1.63	7.41	3.76	5.02
5.2	4.02	1822.9	25.9	131.0	0.69	1.07	7.70	-0.18	1.73
9.1	4.04	1845.2	25.4	142.0	0.64	1.09	7.53	0.36	3.29
12.8	4.13	HH	23.9	150.0	0.74	1.20	7.42	0.36	4.57
15.7	4.24	1970.1	23.1	152.0	0.65	1.15	7.41	0.36	5.77
20.0	4.29	2049.4	30.5	167.0	0.64	1.37	7.34	0.36	7.81
3.8	3.96	1779.3	26.2	123.0	0.49	1.11	7.77	0.36	1.04
6.6	4.09	1811.4	27.8	128.0	0.63	1.10	7.65	0.18	1.67
8.8	4.09	HH	25.7	129.0	0.50	1.16	7.53	0.18	2.22
11.3	4.23	1904.9	25.6	131.0	0.82	1.27	7.49	0.00	2.82
13.8	4.16	1960.1	25.8	133.0	0.53	1.33	7.43	0.54	3.64

Numerical Water Quality and Contaminant Modeling (EL-22)
 Tidal Fresh Potomac River and Maryland Mainstem
 Core Data: Dissolved nutrient and oxygen concentrations in sediment - water flux chambers

STATION	DATE	CORE NO	TIME OF SAMPLE		TIME DELTA (min)	TIME SUM (min)	DO (mg/L)	AA VIAL NO	NH4 (μ M)	NO2+NO3 (μ M)	DIP (μ M)
			(hr)	(min)							
GNCV	12JUL94	B	15	15	0	0	8.70	191	0.4	48.5	0.79
			16	15	60	60	8.40	195	0.4	48.3	0.84
			17	15	60	120	8.28	199	0.5	48.3	0.81
			18	15	60	180	8.18	203	0.6	48.6	0.72
			19	15	60	240	8.09	207	0.9	48.7	0.87
		1	15	15	0	0	8.60	192	2.2	48.1	0.51
			16	15	60	60	7.81	196	4.0	47.9	0.85
			17	15	60	120	7.23	200	5.3	47.3	0.77
			18	15	60	180	6.75	204	7.0	47.3	0.79
			19	15	60	240	6.32	208	8.5	46.8	1.02
		2	15	15	0	0	8.44	193	3.4	48.7	0.61
			16	15	60	60	7.56	197	5.4	48.2	1.03
			17	15	60	120	6.85	201	7.7	47.7	0.99
			18	15	60	180	6.27	205	9.4	47.3	0.96
			19	15	60	240	5.77	209	10.7	47.0	1.06
		3	15	15	0	0	9.13	194	2.1	49.0	0.71
			16	15	60	60	8.12	198	4.1	48.3	0.96
			17	15	60	120	7.44	202	6.0	48.0	0.95
			18	15	60	180	6.85	206	7.3	47.9	0.85
			19	15	60	240	6.35	210	9.1	37.3	1.15

GNCV JULY 1994 continued

Si(OH) ₄ (μ M)	DOC (mg/L)	TCO ₂ (μ M)	DON (μ g/L)	TDN (μ g/L)	DOP (μ g/L)	TDP (μ g/L)	pH	Fe (μ M)	Mn (μ M)
2.3	4.03	1506.0	25.5	74.4	0.58	1.37	8.47	0.00	0.35
0.8	4.17	1511.8	24.3	73.0	0.56	1.40	8.25	0.18	0.29
0.8	4.17	1509.2	25.3	74.1	0.58	1.39	8.41	0.00	0.31
1.3	4.20	1513.0	26.4	75.6	0.71	1.43	8.38	0.00	0.27
1.2	4.18	1515.4	25.4	75.0	0.53	1.40	8.39	0.00	0.31
1.2	4.10	1549.4	26.2	76.5	0.89	1.40	8.39	0.18	0.33
2.6	4.32	1607.0	25.3	77.2	0.66	1.51	8.30	0.18	0.31
3.4	4.36	1660.1	25.7	78.3	0.70	1.47	8.16	0.36	0.31
5.0	4.37	1688.6	25.3	79.6	0.72	1.51	8.20	0.72	0.46
5.2	4.48	1718.4	26.1	81.4	0.57	1.59	8.17	0.18	0.38
1.9	4.15	1544.2	25.3	77.4	0.84	1.45	8.38	0.00	0.95
2.6	4.02	1589.8	26.6	80.2	0.51	1.54	8.26	-0.18	0.75
4.3	4.24	1639.8	26.8	82.2	0.61	1.60	8.13	0.00	0.62
5.3	4.40	1674.6	24.9	81.6	0.59	1.55	8.09	0.18	0.66
5.8	4.31	1704.9	24.5	82.2	0.46	1.52	8.03	0.00	0.55
1.1	4.14	1553.1	27.2	78.3	0.66	1.37	8.45	-0.36	0.35
2.4	4.23	1592.6	26.1	78.5	0.54	1.50	8.35	-0.18	0.36
3.6	S	1644.1	25.6	79.6	0.63	1.58	8.20	0.18	0.38
3.5	4.43	1675.1	27.3	82.5	0.71	1.56	8.16	-0.18	0.40
3.9	5.13	1705.2	36.0	82.4	0.47	1.62	8.10	-0.18	0.44

Numerical Water Quality and Contaminant Modeling (EL-22)

Tidal Fresh Potomac River and Maryland Mainstem

Core Data: Dissolved nutrient and oxygen concentrations in sediment - water flux chambers

STATION	DATE	CORE NO	TIME OF SAMPLE		TIME DELTA (min)	TIME SUM (min)	DO (mg/L)	AA VIAL NO	NH4 (μ M)	NO2+NO3 (μ M)	DIP (μ M)
			(hr)	(min)							
MDPT	13JUL94	B	11	30	0	0	4.85	214	5.1	26.1	1.71
			12	30	60	60	4.79	218	5.4	26.3	1.75
			13	30	60	120	4.79	222	6.5	26.4	1.79
			14	30	60	180	4.78	226	5.3	26.4	1.71
			15	30	60	240	4.77	230	5.4	27.1	1.80
		1	11	30	0	0	4.65	215	8.7	25.6	1.84
			12	30	60	60	3.96	219	13.2	24.7	1.76
			13	30	60	120	3.47	223	17.3	19.9	1.34
			14	30	60	180	3.05	227	19.3	22.5	1.65
			15	30	60	240	2.71	231	21.7	21.0	1.59
		2	11	30	0	0	4.76	216	5.6	26.3	1.73
			12	30	60	60	4.16	220	7.5	24.6	1.76
			13	30	60	120	3.79	224	7.9	24.0	1.63
			14	30	60	180	3.46	228	8.6	26.5	1.74
			15	30	60	240	3.22	400	8.8	20.5	1.52
3	11	30	0	0	4.66	217	10.4	25.1	1.77		
	12	30	60	60	3.78	221	18.3	23.6	1.77		
	13	30	60	120	3.19	225	27.0	26.8	1.55		
	14	30	60	180	2.67	229	31.1	13.7	1.50		
	15	30	60	240	2.30	401	37.7	19.2	1.96		

MDPT JULY 1994 continued

SI(OH) ₄ (μ M)	DOC (mg/L)	TCO ₂ (μ M)	DON (μ g/L)	TDN (μ g/L)	DOP (μ g/L)	TDP (μ g/L)	pH	Fe (μ M)	Mn (μ M)
65.4	2.98	1284.9	20.0	51.2	0.23	1.94	7.42	HH	0.00
66.6	2.92	HH	17.7	49.4	0.19	1.94	7.35	-0.18	0.49
67.0	2.89	HH	17.7	50.6	0.15	1.94	7.34	0.00	0.47
58.3	2.84	HH	17.5	49.2	0.21	1.92	7.34	0.00	0.40
64.6	2.96	1281.1	17.9	50.4	0.14	1.94	7.38	-0.18	0.42
67.3	2.87	1284.4	18.2	52.5	0.20	2.04	7.40	0.36	2.51
68.4	2.86	1303.4	19.0	56.9	0.23	1.99	7.32	0.00	4.46
68.4	2.84	HH	21.6	58.8	0.53	1.87	7.29	0.18	6.01
81.1	2.82	1325.2	20.3	62.1	0.18	1.83	7.26	0.36	7.34
74.5	2.88	1332.0	18.8	61.5	0.28	1.87	7.27	0.54	8.30
64.7	2.95	1285.8	20.1	52.0	0.17	1.90	7.40	-0.18	1.64
68.8	2.93	1305.9	18.4	50.5	0.09	1.85	7.34	7.52	3.84
68.7	2.82	HH	17.9	49.8	0.15	1.78	7.32	-0.36	3.51
72.5	2.88	1344.5	14.6	49.7	0.02	1.76	7.29	-0.18	4.08
73.2	2.94	1369.4	20.9	50.2	0.23	1.75	7.30	-0.18	4.77
65.7	2.93	1290.1	16.0	51.5	0.17	1.94	7.40	0.00	4.17
74.4	2.97	1322.3	17.6	59.5	0.20	1.97	7.31	0.18	7.86
80.0	2.84	HH	9.4	63.2	0.39	1.94	7.26	0.54	10.65
89.4	2.94	1353.4	21.7	66.5	0.38	1.88	7.23	1.25	13.11
82.4	2.88	1383.8	16.9	73.8	0.26	2.22	7.23	2.15	14.71

Numerical Water Quality and Contaminant Modeling (EL-22)
 Tidal Fresh Potomac River and Maryland Mainstem
 Core Data: Dissolved nutrient and oxygen concentrations in sediment - water flux chambers

STATION	DATE	CORE NO	TIME OF SAMPLE		TIME DELTA	TIME SUM	DO (mg/L)	AA VIAL NO	NH4 (μ M)	NO2+NO3 (μ M)	DIP (μ M)
			(hr)	(min)	(min)	(min)					
R-64	14JUL94	B	11	45	0	0	0.27	65	25.9	0.09	1.31
			12	45	60	60	0.16	69	25.7	0.49	1.37
			13	45	60	120	0.12	73	25.5	0.10	1.25
			14	45	60	180	0.09	77	25.7	0.10	1.24
			15	45	60	240	0.06	81	26.4	0.12	1.23
		1	11	45	0	0	0.19	67	27.0	0.24	1.68
			12	45	60	60	0.06	71	28.0	0.26	1.97
			13	45	60	120	0.05	75	30.6	0.39	2.23
			14	45	60	180	0.04	79	32.0	0.36	2.45
			15	45	60	240	0.04	83	34.0	0.12	2.66
		2	11	45	0	0	0.13	66	27.8	0.19	1.61
			12	45	60	60	0.06	70	28.7	0.10	2.03
			13	45	60	120	0.05	74	31.6	0.11	2.29
			14	45	60	180	0.04	78	33.4	0.13	2.50
			15	45	60	240	0.04	82	35.7	0.27	2.73
3	11	45	0	0	0.27	68	27.4	0.12	1.80		
	12	45	60	60	0.13	72	29.2	0.73	2.07		
	13	45	60	120	0.10	76	30.8	0.35	2.34		
	14	45	60	180	0.09	80	31.4	0.97	2.63		
	15	45	60	240	0.09	84	33.2	0.29	2.71		

R 64 JULY 1994 continued

SI(OH) ₄ (μ M)	DOC (mg/L)	TCO ₂ (μ M)	DON (μ g/L)	TDN (μ g/L)	DOP (μ g/L)	TDP (μ g/L)	pH	Fe (μ M)	Mn (μ M)
39.4	2.00	1689.9	23.6	49.6	0.38	1.69	7.32	3.76	2.20
39.5	1.97	1691.3	22.4	48.6	0.28	1.65	7.23	3.40	2.13
40.2	2.02	1688.2	22.7	48.3	0.36	1.61	7.31	3.40	2.24
39.9	1.96	1680.8	22.9	48.7	0.43	1.67	7.33	3.22	2.13
39.9	1.94	1675.3	27.3	53.8	0.42	1.65	7.42	3.22	2.17
42.1	1.99	1709.0	24.0	51.2	0.22	1.90	7.37	3.76	2.20
45.3	2.00	1722.2	26.2	54.5	0.31	2.28	7.36	3.76	2.18
47.6	2.03	1730.1	23.8	54.8	0.44	2.67	7.40	3.76	2.26
49.4	2.02	1737.2	26.7	59.1	0.50	2.95	7.46	3.76	2.28
50.9	2.07	1731.2	28.3	62.4	0.51	3.17	7.53	3.94	2.26
41.8	2.02	1701.8	24.2	52.2	0.52	2.13	7.35	3.94	2.17
44.2	2.20	1722.8	25.1	53.9	0.44	2.47	7.33	3.40	2.18
46.6	2.05	1735.4	24.2	55.9	0.41	2.70	7.37	3.40	2.38
47.9	1.94	1743.4	30.9	64.4	0.75	3.25	7.42	3.58	2.28
49.4	2.08	1745.2	28.9	64.9	0.71	3.44	7.49	3.76	2.28
43.1	2.01	1708.5	24.4	51.9	0.36	2.16	7.40	3.94	2.26
49.3	2.10	1722.0	22.9	52.8	0.47	2.54	7.40	3.58	2.22
52.4	2.00	1730.5	23.9	55.0	0.38	2.72	7.45	3.40	2.22
53.6	2.07	1730.1	26.3	58.7	0.28	2.91	7.51	3.40	2.33
55.1	2.03	1726.9	27.0	60.5	0.64	3.35	7.59	3.58	2.31

Numerical Water Quality and Contaminant Modeling (EL-22)
 Tidal Fresh Potomac River and Maryland Mainstem
 Core Data: Dissolved nutrient and oxygen concentrations in sediment - water flux chambers

STATION	DATE	CORE NO	TIME OF SAMPLE		TIME DELTA (min)	TIME SUM (min)	DO (mg/L)	AA VIAL NO	NH4 (μ M)	NO2+NO3 (μ M)	DIP (μ M)
			hr	min							
HGK	9AUG94	B	10	50	0	0	7.48	170	3.7	109.40	0.29
			11	50	60	60	7.24	174	3.7	109.80	0.27
			12	50	60	120	7.19	178	3.6	109.70	0.33
			13	50	60	180	7.12	183	3.7	109.40	0.29
			14	50	60	240	7.10	191	3.9	109.70	0.30
		1	10	50	0	0	7.21	171	14.6	107.30	0.26
			11	50	60	60	6.50	175	21.0	105.40	0.27
			12	50	60	120	6.02	179	25.6	104.60	0.26
			13	50	60	180	5.62	184	29.6	103.70	0.26
			14	50	60	240	5.27	192	33.2	102.50	0.31
		2	10	50	0	0	7.12	172	13.9	108.10	0.28
			11	50	60	60	6.46	176	20.3	80.90	0.27
			12	50	60	120	6.06	180	26.9	104.70	0.29
			13	50	60	180	5.70	185	31.9	103.70	0.26
			14	50	60	240	5.41	193	37.6	102.60	0.25
3	10	50	0	0	7.30	173	9.4	107.60	0.25		
	11	50	60	60	6.48	177	17.2	106.00	0.27		
	12	50	60	120	5.99	181	21.4	105.10	0.28		
	13	50	60	180	5.57	186	24.8	103.50	0.29		
	14	50	60	240	5.21	194	27.1	102.70	0.31		

HGKNK AUGUST 1994 continued

Si(OH) ₄ (μ M)	DOC (mg/L)	TCO ₂ (μ M)	DON (μ g/L)	TDN (μ g/L)	DOP (μ g/L)	TDP (μ g/L)	pH	Fe (μ M)	Mn (μ M)
10.1	3.59	1738.4	25.2	138.3	0.33	0.62	7.64	0.72	-0.02
10.9	3.67		24.8	138.3	0.35	0.62	7.70	0.18	-0.05
11.3	3.66	1714.9	24.5	137.8	0.33	0.66	7.71	0.18	0.00
10.9	3.68		25.4	138.5	0.33	0.62	7.66	0.18	-0.02
10.6	3.51	1717.8	23.4	137.0	0.32	0.62	7.65	0.18	0.02
13.6	3.57	1807.1	25.6	147.5	0.39	0.65	7.52	0.00	1.31
15.9	3.67	1853.2	23.2	149.6	0.40	0.67	7.47	0.00	1.86
17.9	3.69	1872.6	26.9	157.1	0.38	0.64	7.43	0.18	2.11
19.3	3.78	1903.4	22.9	156.2	0.41	0.67	7.36	0.36	2.18
18.7	3.75	1943.7	29.9	165.6	0.41	0.72	7.33	0.18	2.26
12.4	3.62	1777.6	23.5	145.5	0.33	0.61	7.49	0.18	1.26
15.1	3.70	1837.8	50.0	151.2	0.37	0.64	7.41	0.18	1.82
16.9	3.70	1867.0	24.6	156.2	0.34	0.63	7.36	0.18	2.62
18.0	3.72	1903.2	23.9	159.5	0.33	0.59	7.28	0.18	2.97
19.3	3.66	1931.1	23.0	163.2	0.34	0.59	7.25	0.18	3.31
13.4	3.68	1780.0	27.0	144.0	0.46	0.71	7.56	0.18	1.24
16.0	3.76	1815.6	20.5	143.7	0.37	0.64	7.47	0.00	1.64
17.1	3.73	1849.9	24.0	150.5	1.59	1.87	7.40	0.00	1.86
17.4	3.72	1872.9	23.8	152.1	0.38	0.67	7.37	0.00	1.82
17.6	3.73	1901.4	31.4	161.2	0.37	0.68	7.32	0.18	1.97

Numerical Water Quality and Contaminant Modeling (EL-22)

Tidal Fresh Potomac River and Maryland Mainstem

Core Data: Dissolved nutrient and oxygen concentrations in sediment - water flux chambers

STATION	DATE	CORE NO	TIME OF SAMPLE		TIME DELTA (min)	TIME SUM (min)	DO (mg/L)	AA VIAL NO	NH4 (μ M)	NO2+NO3 (μ M)	DIP (μ M)
			(hr)	(min)							
GNCV	9AUG94	B	14	15	0	0	8.89	187	0.5	58.20	0.63
			15	20	65	65	8.68	195	0.4	57.90	0.78
			16	20	60	125	8.57	199	0.7	58.40	0.79
			17	20	60	185	8.47	204	0.6	58.70	0.71
			18	20	60	245	8.43	209	0.9	54.60	0.68
		1	14	15	0	0	8.51	188	3.3	58.30	0.55
			15	20	65	65	7.76	196	6.3	57.50	0.95
			16	20	60	125	7.23	200	9.8	57.40	0.83
			17	20	60	185	6.70	205	12.2	57.00	0.70
			18	20	60	245	6.23	210	11.9	48.40	0.99
		2	14	15	0	0	8.83	189	1.5	58.60	0.78
			15	20	65	65	8.14	197	2.7	58.60	0.65
			16	20	60	125	7.64	201	4.0	58.40	0.76
			17	20	60	185	7.18	206	5.3	58.20	0.71
			18	20	60	245	6.78	211	6.7	58.50	0.78
		3	14	15	0	0	8.76	190	4.4	58.70	0.81
			15	20	65	65	8.02	198	8.1	58.40	0.89
			16	20	60	125	7.43	202	12.0	57.80	0.93
17	20		60	185	6.69	207	15.0	58.40	0.94		
18	20		60	245	6.19	212	16.9	56.70	0.91		

GNCV AUGUST 1994 continued

SI(OH) ₄ (μ M)	DOC (mg/L)	TCO ₂ (μ M)	DON (μ g/L)	TDN (μ g/L)	DOP (μ g/L)	TDP (μ g/L)	pH	Fe (μ M)	Mn (μ M)
2.5	3.90	1572.4	22.6	81.3	0.25	0.88	8.32	0.00	0.05
2.3	3.98	1497.5	23.0	81.3	0.15	0.93	8.29	0.00	0.05
1.5	4.23		22.3	81.4	0.16	0.95	8.27	0.00	0.05
2.3	3.97	1513.4	22.4	81.7	0.28	0.99	8.23	0.00	0.05
1.6	3.89	1528.3	25.3	80.8	0.23	0.91	8.16	0.00	0.05
2.9	4.00	1552.5	22.5	84.1	0.43	0.98	8.23	0.18	0.13
5.6	4.48	1602.0	23.8	87.6	0.12	1.07	8.10	0.18	0.31
6.6	4.20	1646.5	21.4	88.6	0.29	1.12	7.96	0.18	0.47
8.5	4.49	1695.6	24.3	93.5	0.48	1.18	7.79	0.00	0.58
8.6	4.36	1742.9	33.0	93.3	0.22	1.21	7.69	0.36	0.71
2.7	4.00	1545.9	23.3	83.4	0.13	0.91	8.31	0.00	0.09
3.6	4.35	1569.7	24.8	86.1	0.39	1.04	8.22	0.00	0.09
4.0	4.18	1625.4	21.7	84.1	0.26	1.02	8.15	0.18	0.11
4.8	4.14	1636.1	23.3	86.8	0.39	1.10	8.05	0.00	0.07
5.4	4.34	1665.3	21.5	86.7	0.32	1.10	8.00	0.00	0.13
4.9	4.00	1552.2	22.3	85.4	0.11	0.92	8.27	0.18	0.44
6.1	4.31	1639.6	21.6	88.1	0.13	1.02	8.13	0.00	0.53
8.0	4.25	1669.1	21.5	91.3	0.15	1.08	7.91	0.18	0.87
10.2	4.25		23.2	96.6	0.16	1.10	7.80	0.00	0.86
10.1	4.40	1768.0	23.5	97.1	0.25	1.16	7.74	0.72	1.07

Numerical Water Quality and Contaminant Modeling (EL-22)
 Tidal Fresh Potomac River and Maryland Mainstem
 Core Data: Dissolved nutrient and oxygen concentrations in sediment - water flux chambers

STATION	DATE	CORE NO	TIME OF SAMPLE		TIME DELTA (min)	TIME SUM (min)	DO (mg/L)	AA VIAL NO	NH4 (μM)	NO2+NO3 (μM)	DIP (μM)	
			(hr)	(min)								
MDPT	10AUG94	B	11	0	0	0	5.38	214	3.8	8.71	1.95	
			12	0	60	60	5.33	218	3.7	8.53	1.96	
			13	0	60	120	5.31	222	3.9	8.62	1.96	
			14	0	60	180	5.35	226	4.6	8.95	1.88	
			15	0	60	240	5.31	230	6.4	8.68	2.00	
		1	11	0	0	0	0	5.37	215	4.8	8.62	1.95
			12	0	60	60	60	5.02	219	6.0	8.97	1.99
			13	0	60	120	120	4.76	223	8.6	9.39	2.04
			14	0	60	180	180	4.53	227	8.6	9.07	1.99
			15	0	60	240	240	4.32	231	11.2	9.59	1.92
		2	11	0	0	0	0	5.26	216	6.2	8.71	2.07
			12	0	60	60	60	4.95	220	8.9	9.01	2.12
			13	0	60	120	120	4.73	224	10.4	9.29	2.11
			14	0	60	180	180	4.55	228	11.5	10.06	2.20
			15	0	60	240	240	4.40	232	12.8	9.91	2.11
		3	11	0	0	0	0	5.34	217	6.6	8.45	2.05
			12	0	60	60	60	4.76	221	10.3	8.33	2.04
			13	0	60	120	120	4.37	225	14.4	8.30	2.03
			14	0	60	180	180	4.05	229	17.4	8.77	2.03
			15	0	60	240	240	3.75	233	24.9	7.95	2.11

MDPT AUGUST 1994 continued

Si(OH) ₄ (μ M)	DOC (mg/L)	TCO ₂ (μ M)	DON (μ g/L)	TDN (μ g/L)	DOP (μ g/L)	TDP (μ g/L)	pH	Fe (μ M)	Mn (μ M)
50.4	3.22	1261.6	21.4	33.9	0.20	2.15	7.30	0.00	0.20
48.7	3.13		23.6	35.8	0.22	2.18	7.25	0.18	0.20
50.3	3.19	1262.8	22.4	34.9	0.30	2.26	7.34	0.18	0.18
50.6	3.30		21.3	34.8	0.33	2.21	7.27	0.00	0.18
50.7	3.45	1271.6	19.7	34.8	0.21	2.21	7.23	0.18	0.16
50.2	3.23	1279.9	21.3	34.7	0.30	2.25	7.30	0.00	1.15
50.0	3.50	1279.7	21.0	36.0	0.14	2.13	7.31	0.18	2.17
55.3	3.23	1292.0	20.2	38.2	0.18	2.22	7.28	0.18	2.97
55.9	3.58	1303.7	24.5	42.2	0.29	2.28	7.21	0.18	3.82
57.0	3.52	1316.5	22.7	43.5	0.31	2.23	7.19	0.18	4.59
53.1	3.27	1282.1	21.9	36.8	0.24	2.31	7.32	0.00	1.67
55.1	3.50	1308.8	21.5	39.4	0.25	2.37	7.44	0.00	3.00
59.9	3.26	1343.0	23.1	42.8	0.27	2.38	7.30	0.00	4.11
62.0	3.33	1363.1	22.7	44.3	0.23	2.43	7.33	0.00	4.62
67.8	3.48	1388.1	22.8	45.5	0.32	2.43	7.25	-0.18	5.28
53.0	3.24	1273.6	24.4	39.4	0.25	2.30	7.34	0.00	1.87
52.1	3.55	1287.6	23.3	41.9	0.29	2.33	7.39	0.00	3.31
59.0	3.28	1310.0	22.0	44.7	0.29	2.32	7.30	0.36	4.73
65.3	3.47	1347.8	26.1	52.3	0.46	2.49	7.33	0.36	5.92
72.2	3.56	1345.4	25.0	57.8	0.32	2.43	7.23	0.72	7.12

Numerical Water Quality and Contaminant Modeling (EL-22)

Tidal Fresh Potomac River and Maryland Mainstem

Core Data: Dissolved nutrient and oxygen concentrations in sediment - water flux chambers

STATION	DATE	CORE NO	TIME OF SAMPLE		TIME DELTA (min)	TIME SUM (min)	DO (mg/L)	AA VIAL NO	NH4 (μ M)	NO2+NO3 (μ M)	DIP (μ M)
			(hr)	(min)							
R-64	11AUG94	B	11	15	0	0	0.07	65	24.9	0.16	2.51
			12	20	65	65	0.05	69	24.9	0.16	2.51
			13	20	60	125	0.04	73	24.8	0.13	2.50
			14	22	62	187	0.03	77	25.0	0.16	2.49
			15	22	60	247	0.03	82	25.3	0.21	2.48
		1	11	15	0	0	0.04	66	26.3	0.24	2.87
			12	20	65	65	0.03	70	28.9	0.15	3.20
			13	20	60	125	0.03	74	29.5	0.14	3.39
			14	22	62	187	0.02	78	30.6	0.16	3.54
			15	22	60	247	0.02	83	32.0	0.19	3.72
		2	11	15	0	0	0.06	67	26.8	0.16	2.99
			12	20	65	65	0.03	71	28.5	0.16	3.29
			13	20	60	125	0.02	75	29.6	0.14	3.35
			14	22	62	187	0.02	79	30.4	0.18	3.64
			15	22	60	247	0.02	84	31.6	0.16	3.69
3	11	15	0	0	0.08	68	27.9	0.16	3.16		
	12	20	65	65	0.05	72	29.6	0.14	3.40		
	13	20	60	125	0.04	76	31.9	0.14	3.57		
	14	22	62	187	0.03	80	31.6	0.30	3.68		
	15	22	60	247	0.03	85	33.6	0.19	3.73		

R 64 AUGUST 1994 continued

SI(OH) ₄ (μ M)	DOC (mg/L)	TCO ₂ (μ M)	DON (μ g/L)	TDN (μ g/L)	DOP (μ g/L)	TDP (μ g/L)	pH	Fe (μ M)	Mn (μ M)
44.2	1.85	1882.2	24.94	50.0	47.49	2.77	7.31	5.73	0.87
44.2	1.94	1878.0	28.54	53.6	51.09	2.84	7.35	5.01	0.62
43.9	1.94	1877.9	23.57	48.5	46.00	2.83	7.33	5.37	0.55
44.4	1.91	1877.7	24.14	49.3	46.81	2.79	7.37	5.37	0.60
44.4	1.87	1871.6	22.39	47.9	45.42	2.76	7.37	5.19	0.56
47.5	1.94	1897.4	22.76	49.3	46.43	3.02	7.35	4.66	0.56
47.3	1.97	1922.7	25.55	54.6	51.40	3.48	7.36	4.83	0.60
52.8	1.96	1934.7	26.86	56.5	53.11	3.69	7.37	3.76	0.91
55.7	1.94	1937.4	25.74	56.5	52.96	3.74	7.39	4.83	1.55
56.2	1.97	1946.7	27.41	59.6	55.88	4.03	7.41	5.01	1.66
45.5	1.97	1900.6	24.54	51.5	48.51	3.29	7.36	5.01	0.53
49.4	1.87	1920.8	25.44	54.1	50.81	3.60	7.36	4.48	0.71
50.4	1.88	1930.9	25.46	55.2	51.85	3.73	7.37	4.83	1.06
54.7	2.00	1932.3	28.42	59.0	55.36	3.94	7.39	4.83	1.60
54.8	1.96	1941.0	30.74	62.5	58.81	3.98	7.42	4.83	0.49
48.0	1.89	1912.9	24.94	53.0	49.84	3.48	7.37	4.66	0.78
52.9	1.88	1929.3	25.66	55.4	52.00	3.65	7.36	4.66	0.86
53.3	1.96	1939.6	26.26	58.3	54.73	3.75	7.37	4.83	1.37
55.4	1.92	1942.6	25.70	57.6	53.92	3.90	7.38	5.01	1.66
53.5	1.95	1950.9	31.71	65.5	61.77	4.19	7.43	5.19	1.51

Numerical Water Quality and Contaminant Modeling (EL-22)

Tidal Fresh Potomac River and Maryland Mainstem

Core Data: Dissolved nutrient and oxygen concentrations in sediment - water flux chambers

STATION	DATE	CORE NO	TIME OF SAMPLE		TIME DELTA (min)	TIME SUM (min)	DO (mg/L)	AA VIAL NO	NH4 (μM)	NO2+NO3 (μM)	DIP (μM)
			(hr)	(min)							
HGNK	13OCT94	B	10	15	0	0	8.11	171	12.1	202.00	0.34
			11	15	60	60	8.05	175	12.2	202.00	0.34
			12	17	62	122	8.05	180	11.9	198.00	0.34
			13	17	60	182	8.07	184	11.8	197.00	0.59
			14	15	58	240	8.08	188	12.3	193.00	0.35
		1	10	15	0	0	8.06	172	18.3	219.00	0.35
			11	15	60	60	7.61	176	22.3	203.00	0.36
			12	17	62	122	7.27	181	26.0	202.00	0.35
			13	17	60	182	6.99	185	29.0	198.00	0.38
			14	15	58	240	6.76	189	31.1	198.00	0.37
		2	10	15	0	0	7.78	173	19.5	204.00	0.37
			11	15	60	60	7.44	177	23.5	203.00	0.35
			12	17	62	122	7.15	182	27.1	202.00	0.37
			13	17	60	182	6.93	186	29.6	204.00	0.35
			14	15	58	240	6.71	190	32.9	201.00	0.34
		3	10	15	0	0	7.86	174	18.9	208.00	0.32
			11	15	60	60	7.53	178	23.8	204.00	0.36
			12	17	62	122	7.27	183	26.0	203.00	0.34
			13	17	60	182	7.06	187	30.0	202.00	0.35
			14	15	58	240	6.88	191	32.3	201.00	0.35

HGK OCTOBER 1994 continued

Si(OH) ₄ (μ M)	DOC (mg/L)	TCO ₂ (μ M)	DON (μ g/L)	TDN (μ g/L)	DOP (μ g/L)	TDP (μ g/L)	pH	Fe (μ M)	Mn (μ M)
49.9	3.08	1931.2	24.9	239	0.23	0.57	7.74	0.36	0.66
51.4	3.05		27.8	242	0.27	0.61	7.72	-0.18	0.05
57.8	3.03	1934.2	19.1	229	0.25	0.59	7.64	-0.18	0.55
67.0	2.98		25.2	234	-0.03	0.56	7.62	-0.36	0.51
76.1	3.01	1968.3	27.7	233	0.22	0.57	7.74	-0.18	0.56
50.1	3.16	1963.8	5.7	243	0.23	0.58	7.69	0.00	1.22
51.1	3.25	1974.0	18.7	244	0.27	0.63	7.61	-0.18	1.40
50.5	3.11	2000.7	22.0	250	0.23	0.58	7.50	-0.36	1.60
52.2	3.17	2018.5	24.0	251	0.23	0.61	7.50	-0.36	1.69
54.0	3.16	2039.5	22.9	252	0.27	0.64	7.57	-0.36	1.73
48.8	3.16	1975.5	26.5	250	0.22	0.59	7.67	-0.36	1.20
49.9	3.19	1980.5	20.5	247	0.23	0.58	7.59	-0.36	1.35
51.4	3.07	1995.5	21.9	251	0.25	0.62	7.50	-0.54	1.47
49.6	3.16	2014.7	20.4	254	0.23	0.58	7.50	-0.54	1.58
51.0	3.17	2026.6	21.1	255	0.25	0.59	7.55	-0.72	1.67
49.4	3.18	1952.4	16.1	243	0.27	0.59	7.70	-0.18	1.11
50.3	3.14	1974.5	18.2	246	0.25	0.61	7.59	-0.54	1.33
50.4	3.15	1998.5	19.0	248	0.25	0.59	7.56	-0.54	1.37
49.2	3.16	2008.3	19.0	251	0.25	0.60	7.54	-0.72	1.46
51.0	3.15	2024.0	21.7	255	0.26	0.61	7.57	-0.54	1.51

Numerical Water Quality and Contaminant Modeling (EL-22)
 Tidal Fresh Potomac River and Maryland Mainstem
 Core Data: Dissolved nutrient and oxygen concentrations in sediment - water flux chambers

STATION	DATE	CORE NO	TIME OF SAMPLE (hr min)		TIME DELTA (min)	TIME SUM (min)	DO (mg/L)	AA VIAL NO	NH4 (μ M)	NO2+NO3 (μ M)	DIP (μ M)
GNCV	13OCT94	B	13	53	0	0	9.91	192	0.6	137.00	0.15
			14	55	62	62	9.83	196	0.1	137.00	0.15
			15	55	60	122	9.79	200	0.6	137.00	0.13
			16	55	60	182	9.76	205	0.1	137.00	0.14
			17	55	60	242	9.71	210	0.3	136.00	0.14
		1	13	53	0	0	9.36	193	2.1	136.00	0.17
			14	55	62	62	8.92	197	2.9	136.00	0.16
			15	55	60	122	8.66	201	3.7	136.00	0.16
			16	55	60	182	8.42	206	4.0	135.00	0.17
			17	55	60	242	8.17	211	4.6	134.00	0.18
		2	13	53	0	0	9.08	194	4.2	135.00	0.15
			14	55	62	62	8.63	198	6.1	136.00	0.19
			15	55	60	122	8.32	202	7.5	134.00	0.18
			16	55	60	182	8.01	207	9.6	132.00	0.37
			17	55	60	242	7.73	212	9.6	131.00	0.21
		3	13	53	0	0	9.63	195	1.4	136.00	0.16
			14	55	62	62	9.22	199	2.2	136.00	0.15
			15	55	60	122	8.92	203	3.2	136.00	0.17
16	55		60	182	8.67	208	3.8	135.00	0.20		
17	55		60	242	8.42	213	3.5	134.00	0.17		

GNCV OCTOBER 1994 continued

Si(OH) ₄ (μ M)	DOC (mg/L)	TCO ₂ (μ M)	DON (μ g/L)	TDN (μ g/L)	DOP (μ g/L)	TDP (μ g/L)	pH	Fe (μ M)	Mn (μ M)
27.4	3.42	1648.7	25.4	163.0	0.15	0.30	8.12	-0.72	0.51
26.3	3.47	1729.4	23.9	161.0	0.16	0.31	8.13	-0.72	0.49
27.6	3.46	HH	24.4	162.0	0.28	0.41	8.05	-0.90	0.53
26.6	3.54	1650.4	22.9	160.0	0.24	0.38	8.06	-0.72	0.49
29.5	3.46	1664.4	25.7	162.0	0.17	0.31	8.14	-0.72	0.51
27.9	3.52	1691.7	22.9	161.0	0.19	0.36	8.19	-0.54	0.60
27.8	3.58	1723.7	24.1	163.0	0.23	0.39	8.16	-0.72	0.60
29.6	3.48	1741.4	21.3	161.0	0.24	0.40	8.04	-0.90	0.55
27.9	3.54	1774.3	22.0	161.0	0.22	0.39	7.91	-0.90	0.56
28.2	3.53	1789.3	24.4	163.0	0.28	0.46	7.98	-0.72	0.58
29.7	3.64	1715.5	25.8	165.0	0.31	0.46	8.13	-0.54	0.86
33.2	4.00	1765.4	32.9	175.0	1.37	1.56	8.06	-0.90	0.87
34.8	3.48	1795.1	26.5	168.0	0.20	0.38	7.95	-0.90	0.91
35.6	4.12	1844.8	21.4	163.0	0.06	0.43	7.73	-0.72	0.95
37.5	3.55	1866.7	24.4	165.0	0.18	0.39	7.83	-0.72	0.98
27.9	3.55	1684.1	26.6	164.0	0.19	0.35	8.07	-0.54	0.60
27.8	3.48	1715.7	22.8	161.0	0.25	0.40	8.18	-0.72	0.56
26.9	3.65	1737.1	23.8	163.0	0.33	0.50	8.05	-0.72	0.55
26.7	3.60	1777.7	20.2	159.0	0.20	0.40	7.89	-0.72	0.51
27.7	3.52	1779.6	26.5	164.0	0.31	0.48	8.00	-0.72	0.51

Numerical Water Quality and Contaminant Modeling (EL-22)
 Tidal Fresh Potomac River and Maryland Mainstem
 Core Data: Dissolved nutrient and oxygen concentrations in sediment - water flux chambers

STATION	DATE	CORE NO	TIME OF SAMPLE		TIME DELTA (min)	TIME SUM (min)	DO (mg/L)	AA VIAL NO	NH4 (μ M)	NO2+NO3 (μ M)	DIP (μ M)
			(hr)	(min)							
MDPT	14OCT94	B	11	10	0	0	7.54	215	7.5	40.10	1.84
			12	20	70	70	7.49	219	8.0	39.80	1.87
			13	20	60	130	7.51	223	7.8	40.00	1.83
			14	20	60	190	7.50	227	7.6	40.20	1.92
			15	20	60	250	7.49	231	7.9	40.10	1.86
		1	11	10	0	0	7.63	216	8.4	39.80	1.90
			12	20	70	70	7.28	220	9.3	40.40	1.90
			13	20	60	130	7.06	224	9.6	40.40	1.96
			14	20	60	190	6.88	228	12.4	40.80	1.91
			15	20	60	250	6.68	232	11.4	41.10	1.81
		2	11	10	0	0	7.36	217	9.8	39.10	1.71
			12	20	70	70	6.58	221	10.9	37.90	1.78
			13	20	60	130	6.77	225	12.6	37.30	1.67
			14	20	60	190	6.63	229	14.3	35.90	1.68
			15	20	60	250	6.50	233	13.5	35.30	1.65
3	11	10	0	0	7.41	218	9.0	40.10	1.85		
	12	20	70	70	7.04	222	10.1	39.80	1.84		
	13	20	60	130	6.86	226	10.4	39.90	1.94		
	14	20	60	190	6.75	230	11.1	40.30	1.91		
	15	20	60	250	6.57	234	11.0	40.10	1.79		

MDPT OCTOBER 1994 continued

SI(OH) ₄ (μ M)	DOC (mg/L)	TCO ₂ (μ M)	DON (μ g/L)	TDN (μ g/L)	DOP (μ g/L)	TDP (μ g/L)	pH	Fe (μ M)	Mn (μ M)
46.4	3.63	1451.2	24.6	72.2	0.20	2.04	7.46	-0.36	0.66
46.6	3.61	HH	22.1	69.9	0.15	2.02	7.45	-0.36	0.62
47.6	3.57	1472.8	21.7	69.5	0.18	2.01	7.46	-0.18	0.64
42.2	3.64	HH	21.5	69.3	0.14	2.06	7.46	-0.54	0.64
44.0	3.58	S	23.1	71.1	0.16	2.02	7.45	-0.36	0.62
46.3	3.58	1468.4	23.4	71.6	0.15	2.05	7.53	-0.36	1.60
48.2	3.67	1476.7	24.5	74.2	0.19	2.09	7.49	-0.36	2.20
48.4	3.81	1496.4	25.0	75.0	0.19	2.15	7.44	-0.18	2.44
49.8	3.62	1502.3	22.6	75.8	0.22	2.13	7.41	-0.36	2.58
50.1	3.62	S	24.5	77.0	0.34	2.15	7.42	-0.18	2.62
51.2	3.55	1468.4	21.9	70.8	0.31	2.02	7.53	-0.18	1.97
56.8	3.48	1509.9	22.2	71.0	0.16	1.94	7.53	-0.54	3.11
83.0	3.42	1565.4	28.4	78.3	0.31	1.98	7.50	-0.36	3.80
88.3	3.51	1612.7	20.3	70.5	0.17	1.85	7.51	-0.36	4.04
106.4	3.36	1657.8	19.1	67.9	0.14	1.79	7.52	-0.36	4.17
47.4	3.62	1462.3	25.6	74.7	0.28	2.13	7.54	-0.54	1.69
46.8	3.62	1474.2	28.6	78.5	0.39	2.23	7.51	-0.54	2.09
49.0	3.58	1495.4	20.8	71.1	0.12	2.06	7.48	-0.36	2.24
48.5	3.63	1500.2	20.2	71.6	0.20	2.11	7.47	-0.54	2.33
50.5	3.57	1517.9	22.1	73.2	0.28	2.07	7.49	-0.54	2.40

Numerical Water Quality and Contaminant Modeling (EL-22)

Tidal Fresh Potomac River and Maryland Mainstem

Core Data: Dissolved nutrient and oxygen concentrations in sediment - water flux chambers

STATION	DATE	CORE NO	TIME OF SAMPLE (hr min)	TIME DELTA (min)	TIME SUM (min)	DO (mg/L)	AA VIAL NO	NH4 (μ M)	NO2+NO3 (μ M)	DIP (μ M)
R-64	17OCT94	B	16 15	0	0	7.39	128	5.4	1.91	0.15
			17 15	60	60	7.39	132	4.8	2.14	0.18
			18 15	60	120	7.45	136	4.9	1.92	0.14
			19 15	60	180	7.44	140	4.8	1.94	0.17
			20 15	60	240	7.44	144	4.9	2.11	0.16
		1	16 15	0	0	6.94	129	8.6	1.95	0.27
			17 15	60	60	6.65	133	11.0	1.91	0.28
			18 15	60	120	6.33	137	13.3	1.82	0.28
			19 15	60	180	6.03	141	15.0	1.79	0.29
			20 15	60	240	5.76	145	17.0	1.75	0.36
		2	16 15	0	0	6.84	130	8.2	1.89	0.39
			17 15	60	60	6.52	134	10.5	1.86	0.40
			18 15	60	120	6.21	138	13.2	1.84	0.47
			19 15	60	180	5.97	142	14.9	1.82	0.58
			20 15	60	240	5.79	146	16.7	1.80	0.67
		3	16 15	0	0	6.92	131	11.8	1.85	1.04
			17 15	60	60	6.38	135	14.9	1.80	1.07
			18 15	60	120	5.89	139	17.3	1.75	1.13
			19 15	60	180	5.54	143	19.9	1.70	1.17
			20 15	60	240	5.21	147	21.0	1.61	1.24

R 64 OCTOBER 1994 continued

SI(OH) ₄ (μ M)	DOC (mg/L)	TCO ₂ (μ M)	DON (μ g/L)	TDN (μ g/L)	DOP (μ g/L)	TDP (μ g/L)	pH	Fe (μ M)	Mn (μ M)
34.2	2.26	1638.9	23.9	31.2	0.23	0.38	7.73	2.15	1.11
35.4	2.44	1646.8	27.3	34.2	0.23	0.41	7.74	2.15	1.09
35.8	2.27		23.3	30.1	0.20	0.34	7.72	2.33	1.11
37.2	2.30	1634.0	21.1	27.8	0.20	0.37	7.75	2.33	1.11
39.1	2.26	1644.8	19.2	26.2	0.19	0.35	7.61	2.15	1.09
35.9	2.32	1641.8	24.0	34.5	0.21	0.48	7.85	2.69	1.15
38.2	2.31	1679.6	23.5	36.4	0.19	0.47	7.84	2.33	1.16
40.3	2.32	1686.6	23.1	38.2	0.19	0.47	7.78	2.15	1.16
41.8	2.33	1718.1	23.8	40.6	0.31	0.60	7.75	2.33	1.15
43.2	2.30	1741.5	22.5	41.2	0.15	0.51	7.69	2.15	1.15
35.7	2.28	1635.7	22.6	32.7	0.18	0.57	7.88	2.15	1.15
38.8	2.27	1679.7	22.7	35.1	0.19	0.59	7.89	2.51	1.20
41.2	2.33	1701.3	23.4	38.4	0.17	0.64	7.79	2.51	1.16
43.3	2.26	1725.4	21.5	38.2	0.18	0.76	7.78	2.33	1.22
45.1	2.33	1738.3	20.9	39.4	0.14	0.81	7.74	2.51	1.22
37.7	2.37	1689.6	27.5	41.1	0.17	1.21	7.87	2.69	1.38
40.4	2.32	1732.7	23.7	40.4	0.20	1.27	7.89	2.33	1.37
42.2	2.31	1745.4	26.6	45.6	0.19	1.32	7.74	2.33	1.35
43.6	2.37	1756.4	23.8	45.4	0.23	1.40	7.76	2.15	1.35
45.6	2.31	1779.4	22.6	45.2	0.19	1.43	7.74	2.33	1.38

Numerical Water Quality and Contaminant Modeling (EL-22)
 Tidal Fresh Potomac River and Maryland Mainstem
 Sulfate Data: Sulfate concentration in sediment pore water

STATION	MONTH	TIME DAYS	REPLICATE NUMBER*	SO4 (μ M)	SO4 (mg/L)
HGNK	MAY	0	1:1	31.95	3.07
HGNK	MAY	0	1:2	50.93	4.89
HGNK	MAY	0	1:3	51.79	4.97
HGNK	MAY	2	2:1	9.49	0.91
HGNK	MAY	2	2:2	9.82	0.94
HGNK	MAY	2	2:3	12.64	1.21
HGNK	MAY	4	3:1	5.44	0.52
HGNK	MAY	4	3:2	5.32	0.51
HGNK	MAY	4	3:3	5.23	0.50
HGNK	MAY	6	4:1	8.42	0.81
HGNK	MAY	6	4:2	6.06	0.58
HGNK	MAY	6	4:3	4.39	0.42
GNCV	MAY	0	1:1	31.80	3.05
GNCV	MAY	0	1:2	34.82	3.34
GNCV	MAY	0	1:3	35.82	3.44
GNCV	MAY	2	2:1	10.29	0.99
GNCV	MAY	2	2:2	9.24	0.89
GNCV	MAY	2	2:3	10.33	0.99
GNCV	MAY	4	3:1	3.51	0.34
GNCV	MAY	4	3:2	S	S
GNCV	MAY	4	3:3	5.27	0.51
GNCV	MAY	6	4:1	5.37	0.52
GNCV	MAY	6	4:2	7.11	0.68
GNCV	MAY	6	4:3	6.92	0.66
MDPT	MAY	0	1:1	257.30	24.70
MDPT	MAY	0	1:2	303.76	29.16
MDPT	MAY	0	1:3	254.14	24.40
MDPT	MAY	2	2:1	67.34	6.46
MDPT	MAY	2	2:2	31.72	3.04
MDPT	MAY	2	2:3	27.14	2.61
MDPT	MAY	4	3:1	5.41	0.52
MDPT	MAY	4	3:2	6.40	0.61
MDPT	MAY	4	3:3	6.33	0.61
MDPT	MAY	6	4:1	6.73	0.65
MDPT	MAY	6	4:2	S	S
MDPT	MAY	6	4:3	8.40	0.81
R 64	MAY	0	1:1	7737.05	742.76
R 64	MAY	0	1:2	6020.26	577.94
R 64	MAY	0	1:3	7946.50	762.86
R 64	MAY	2	2:1	7596.75	729.29
R 64	MAY	2	2:2	6405.87	614.96
R 64	MAY	2	2:3	6996.70	671.68
R 64	MAY	4	3:1	8896.74	854.09
R 64	MAY	4	3:2	4266.83	409.62
R 64	MAY	4	3:3	5641.48	541.58
R 64	MAY	6	4:1	6645.33	637.95
R 64	MAY	6	4:2	5138.13	493.26
R 64	MAY	6	4:3	2676.10	256.91

*Note: Replicate number denotes time point and replicate (2:1 is the first replicate of the second time point).

Numerical Water Quality and Contaminant Modeling (EL-22)
Tidal Fresh Potomac River and Maryland Mainstem
Sulfate Data: Sulfate concentration in sediment pore water

STATION	MONTH	TIME DAYS	REPLICATE NUMBER*	SO4 (μ M)	SO4 (mg/L)
HGNK	JULY	0	1:1	25.81	2.48
HGNK	JULY	0	1:2	20.70	1.99
HGNK	JULY	0	1:3	S	S
HGNK	JULY	2	2:1	24.03	2.31
HGNK	JULY	2	2:2	18.51	1.78
HGNK	JULY	2	2:3	17.35	1.67
HGNK	JULY	4	3:1	24.93	2.39
HGNK	JULY	4	3:2	20.46	1.96
HGNK	JULY	4	3:3	24.74	2.38
HGNK	JULY	6	4:1	23.05	2.21
HGNK	JULY	6	4:2	31.35	3.01
HGNK	JULY	6	4:3	25.24	2.42
GNVC	JULY	0	1:1	65.93	6.33
GNVC	JULY	0	1:2	S	S
GNVC	JULY	0	1:3	73.44	7.05
GNVC	JULY	2	2:1	17.15	1.65
GNVC	JULY	2	2:2	21.95	2.11
GNVC	JULY	2	2:3	21.63	2.08
GNVC	JULY	4	3:1	16.35	1.57
GNVC	JULY	4	3:2	17.73	1.70
GNVC	JULY	4	3:3	15.92	1.53
GNVC	JULY	6	4:1	21.93	2.11
GNVC	JULY	6	4:2	16.45	1.58
GNVC	JULY	6	4:3	17.30	1.66
MDPT	JULY	0	1:1	1296.66	124.48
MDPT	JULY	0	1:2	1243.72	119.40
MDPT	JULY	0	1:3	1463.14	140.46
MDPT	JULY	2	2:1	848.44	81.45
MDPT	JULY	2	2:2	703.65	67.55
MDPT	JULY	2	2:3	720.67	69.18
MDPT	JULY	4	3:1	251.75	24.17
MDPT	JULY	4	3:2	676.84	64.98
MDPT	JULY	4	3:3	1063.89	102.13
MDPT	JULY	6	4:1	22.27	2.14
MDPT	JULY	6	4:2	22.11	2.12
MDPT	JULY	6	4:3	397.74	38.18
R 64	JULY	0	1:1	6734.80	646.54
R 64	JULY	0	1:2	6332.51	607.92
R 64	JULY	0	1:3	5793.16	556.14
R 64	JULY	2	2:1	2810.01	269.76
R 64	JULY	2	2:2	3679.74	353.26
R 64	JULY	2	2:3	2606.45	250.22
R 64	JULY	4	3:1	1143.99	109.82
R 64	JULY	4	3:2	1481.78	142.25
R 64	JULY	4	3:3	770.91	74.01
R 64	JULY	6	4:1	188.38	18.08
R 64	JULY	6	4:2	226.82	21.77
R 64	JULY	6	4:3	296.62	28.48

*Note: Replicate number denotes time point and replicate (2:1 is the first replicate of the second time point).

Numerical Water Quality and Contaminant Modeling (EL-22)
 Tidal Fresh Potomac River and Maryland Mainstem
 Sulfate Data: Sulfate concentration in sediment pore water

STATION	MONTH	TIME DAYS	REPLICATE NUMBER*	SO4 (μM)	SO4 (mg/L)
HGNK	AUGUST	0	1:1	105.62	10.14
HGNK	AUGUST	0	1:2	99.19	9.52
HGNK	AUGUST	0	1:3	97.78	9.39
HGNK	AUGUST	2	2:1	91.73	8.81
HGNK	AUGUST	2	2:2	83.27	7.99
HGNK	AUGUST	2	2:3	91.64	8.80
HGNK	AUGUST	4	3:1	S	S
HGNK	AUGUST	4	3:2	86.85	8.34
HGNK	AUGUST	4	3:3	90.26	8.66
HGNK	AUGUST	6	4:1	81.75	7.85
HGNK	AUGUST	6	4:2	92.57	8.89
HGNK	AUGUST	6	4:3	94.16	9.04
GNVC	AUGUST	0	1:1	131.37	12.61
GNVC	AUGUST	0	1:2	128.33	12.32
GNVC	AUGUST	0	1:3	137.23	13.17
GNVC	AUGUST	2	2:1	89.94	8.63
GNVC	AUGUST	2	2:2	93.45	8.97
GNVC	AUGUST	2	2:3	94.06	9.03
GNVC	AUGUST	4	3:1	97.82	9.39
GNVC	AUGUST	4	3:2	94.50	9.07
GNVC	AUGUST	4	3:3	96.65	9.28
GNVC	AUGUST	6	4:1	92.29	8.86
GNVC	AUGUST	6	4:2	95.62	9.18
GNVC	AUGUST	6	4:3	89.70	8.61
MDPT	AUGUST	0	1:1	1603.00	153.89
MDPT	AUGUST	0	1:2	1930.89	185.37
MDPT	AUGUST	0	1:3	1885.96	181.05
MDPT	AUGUST	2	2:1	1194.36	114.66
MDPT	AUGUST	2	2:2	1269.88	121.91
MDPT	AUGUST	2	2:3	1819.62	174.68
MDPT	AUGUST	4	3:1	856.11	82.19
MDPT	AUGUST	4	3:2	1159.09	111.27
MDPT	AUGUST	4	3:3	1356.02	130.18
MDPT	AUGUST	6	4:1	1060.91	101.85
MDPT	AUGUST	6	4:2	1698.10	163.02
MDPT	AUGUST	6	4:3	169.06	16.23
R 64	AUGUST	0	1:1	7927.16	761.01
R 64	AUGUST	0	1:2	8090.11	776.65
R 64	AUGUST	0	1:3	7735.00	742.56
R 64	AUGUST	2	2:1	5765.94	553.53
R 64	AUGUST	2	2:2	6192.51	594.48
R 64	AUGUST	2	2:3	5860.96	562.65
R 64	AUGUST	4	3:1	4937.80	474.03
R 64	AUGUST	4	3:2	3540.61	339.90
R 64	AUGUST	4	3:3	3322.79	318.99
R 64	AUGUST	6	4:1	2752.21	264.21
R 64	AUGUST	6	4:2	2970.90	285.21
R 64	AUGUST	6	4:3	3005.65	288.54

*Note: Replicate number denotes time point and replicate (2:1 is the first replicate of the second time point).

Numerical Water Quality and Contaminant Modeling (EL-22)
 Tidal Fresh Potomac River and Maryland Mainstem
 Sulfate Data: Sulfate concentration in sediment pore water

STATION	MONTH	TIME DAYS	REPLICATE NUMBER*	SO4 (μ M)	SO4 (mg/L)
HGNK	OCTOBER	0	1:1	75.50	7.25
HGNK	OCTOBER	0	1:2	57.11	5.48
HGNK	OCTOBER	0	1:3	59.55	5.72
HGNK	OCTOBER	2	2:1	26.76	2.57
HGNK	OCTOBER	2	2:2	24.03	2.31
HGNK	OCTOBER	2	2:3	21.22	2.04
HGNK	OCTOBER	4	3:1	26.58	2.55
HGNK	OCTOBER	4	3:2	16.45	1.58
HGNK	OCTOBER	4	3:3	15.69	1.51
HGNK	OCTOBER	6	4:1	18.66	1.79
HGNK	OCTOBER	6	4:2	18.26	1.75
HGNK	OCTOBER	6	4:3	16.81	1.61
GNCV	OCTOBER	0	1:1	59.51	5.71
GNCV	OCTOBER	0	1:2	41.51	3.98
GNCV	OCTOBER	0	1:3	72.95	7.00
GNCV	OCTOBER	2	2:1	28.58	2.74
GNCV	OCTOBER	2	2:2	42.62	4.09
GNCV	OCTOBER	2	2:3	65.41	6.28
GNCV	OCTOBER	4	3:1	21.12	2.03
GNCV	OCTOBER	4	3:2	45.02	4.32
GNCV	OCTOBER	4	3:3	20.77	1.99
GNCV	OCTOBER	6	4:1	23.16	2.22
GNCV	OCTOBER	6	4:2	30.01	2.88
GNCV	OCTOBER	6	4:3	41.65	4.00
MDPT	OCTOBER	0	1:1	3265.59	313.50
MDPT	OCTOBER	0	1:2	2766.76	265.61
MDPT	OCTOBER	0	1:3	3281.43	315.02
MDPT	OCTOBER	2	2:1	3657.00	351.07
MDPT	OCTOBER	2	2:2	1744.53	167.48
MDPT	OCTOBER	2	2:3	3311.57	317.91
MDPT	OCTOBER	4	3:1	1994.45	191.47
MDPT	OCTOBER	4	3:2	2736.26	262.68
MDPT	OCTOBER	4	3:3	3494.82	335.50
MDPT	OCTOBER	6	4:1	3014.48	289.39
MDPT	OCTOBER	6	4:2	2679.15	257.20
MDPT	OCTOBER	6	4:3	1830.66	175.74
R 64	OCTOBER	0	1:1	6247.23	599.73
R 64	OCTOBER	0	1:2	5566.24	534.36
R 64	OCTOBER	0	1:3	5712.76	548.43
R 64	OCTOBER	2	2:1	3227.08	309.80
R 64	OCTOBER	2	2:2	3270.83	314.00
R 64	OCTOBER	2	2:3	3455.21	331.70
R 64	OCTOBER	4	3:1	1579.03	151.59
R 64	OCTOBER	4	3:2	1910.44	183.40
R 64	OCTOBER	4	3:3	1892.90	181.72
R 64	OCTOBER	6	4:1	439.38	42.18
R 64	OCTOBER	6	4:2	707.15	67.89
R 64	OCTOBER	6	4:3	780.88	74.96

*Note: Replicate number denotes time point and replicate (2:1 is the first replicate of the second time point).

Appendix E

Sediment-Water Oxygen and Nutrient Flux Data Tables

Station	Date	Parameter	Value	Units	Depth (cm)	Notes
101	10/15/01	O ₂	0.5	mg/L	0	
101	10/15/01	O ₂	0.2	mg/L	1	
101	10/15/01	O ₂	0.1	mg/L	2	
101	10/15/01	O ₂	0.0	mg/L	3	
101	10/15/01	O ₂	0.0	mg/L	4	
101	10/15/01	O ₂	0.0	mg/L	5	
101	10/15/01	O ₂	0.0	mg/L	6	
101	10/15/01	O ₂	0.0	mg/L	7	
101	10/15/01	O ₂	0.0	mg/L	8	
101	10/15/01	O ₂	0.0	mg/L	9	
101	10/15/01	O ₂	0.0	mg/L	10	
101	10/15/01	O ₂	0.0	mg/L	11	
101	10/15/01	O ₂	0.0	mg/L	12	
101	10/15/01	O ₂	0.0	mg/L	13	
101	10/15/01	O ₂	0.0	mg/L	14	
101	10/15/01	O ₂	0.0	mg/L	15	
101	10/15/01	O ₂	0.0	mg/L	16	
101	10/15/01	O ₂	0.0	mg/L	17	
101	10/15/01	O ₂	0.0	mg/L	18	
101	10/15/01	O ₂	0.0	mg/L	19	
101	10/15/01	O ₂	0.0	mg/L	20	
101	10/15/01	O ₂	0.0	mg/L	21	
101	10/15/01	O ₂	0.0	mg/L	22	
101	10/15/01	O ₂	0.0	mg/L	23	
101	10/15/01	O ₂	0.0	mg/L	24	
101	10/15/01	O ₂	0.0	mg/L	25	
101	10/15/01	O ₂	0.0	mg/L	26	
101	10/15/01	O ₂	0.0	mg/L	27	
101	10/15/01	O ₂	0.0	mg/L	28	
101	10/15/01	O ₂	0.0	mg/L	29	
101	10/15/01	O ₂	0.0	mg/L	30	
101	10/15/01	O ₂	0.0	mg/L	31	
101	10/15/01	O ₂	0.0	mg/L	32	
101	10/15/01	O ₂	0.0	mg/L	33	
101	10/15/01	O ₂	0.0	mg/L	34	
101	10/15/01	O ₂	0.0	mg/L	35	
101	10/15/01	O ₂	0.0	mg/L	36	
101	10/15/01	O ₂	0.0	mg/L	37	
101	10/15/01	O ₂	0.0	mg/L	38	
101	10/15/01	O ₂	0.0	mg/L	39	
101	10/15/01	O ₂	0.0	mg/L	40	
101	10/15/01	O ₂	0.0	mg/L	41	
101	10/15/01	O ₂	0.0	mg/L	42	
101	10/15/01	O ₂	0.0	mg/L	43	
101	10/15/01	O ₂	0.0	mg/L	44	
101	10/15/01	O ₂	0.0	mg/L	45	
101	10/15/01	O ₂	0.0	mg/L	46	
101	10/15/01	O ₂	0.0	mg/L	47	
101	10/15/01	O ₂	0.0	mg/L	48	
101	10/15/01	O ₂	0.0	mg/L	49	
101	10/15/01	O ₂	0.0	mg/L	50	
101	10/15/01	O ₂	0.0	mg/L	51	
101	10/15/01	O ₂	0.0	mg/L	52	
101	10/15/01	O ₂	0.0	mg/L	53	
101	10/15/01	O ₂	0.0	mg/L	54	
101	10/15/01	O ₂	0.0	mg/L	55	
101	10/15/01	O ₂	0.0	mg/L	56	
101	10/15/01	O ₂	0.0	mg/L	57	
101	10/15/01	O ₂	0.0	mg/L	58	
101	10/15/01	O ₂	0.0	mg/L	59	
101	10/15/01	O ₂	0.0	mg/L	60	
101	10/15/01	O ₂	0.0	mg/L	61	
101	10/15/01	O ₂	0.0	mg/L	62	
101	10/15/01	O ₂	0.0	mg/L	63	
101	10/15/01	O ₂	0.0	mg/L	64	
101	10/15/01	O ₂	0.0	mg/L	65	
101	10/15/01	O ₂	0.0	mg/L	66	
101	10/15/01	O ₂	0.0	mg/L	67	
101	10/15/01	O ₂	0.0	mg/L	68	
101	10/15/01	O ₂	0.0	mg/L	69	
101	10/15/01	O ₂	0.0	mg/L	70	
101	10/15/01	O ₂	0.0	mg/L	71	
101	10/15/01	O ₂	0.0	mg/L	72	
101	10/15/01	O ₂	0.0	mg/L	73	
101	10/15/01	O ₂	0.0	mg/L	74	
101	10/15/01	O ₂	0.0	mg/L	75	
101	10/15/01	O ₂	0.0	mg/L	76	
101	10/15/01	O ₂	0.0	mg/L	77	
101	10/15/01	O ₂	0.0	mg/L	78	
101	10/15/01	O ₂	0.0	mg/L	79	
101	10/15/01	O ₂	0.0	mg/L	80	
101	10/15/01	O ₂	0.0	mg/L	81	
101	10/15/01	O ₂	0.0	mg/L	82	
101	10/15/01	O ₂	0.0	mg/L	83	
101	10/15/01	O ₂	0.0	mg/L	84	
101	10/15/01	O ₂	0.0	mg/L	85	
101	10/15/01	O ₂	0.0	mg/L	86	
101	10/15/01	O ₂	0.0	mg/L	87	
101	10/15/01	O ₂	0.0	mg/L	88	
101	10/15/01	O ₂	0.0	mg/L	89	
101	10/15/01	O ₂	0.0	mg/L	90	
101	10/15/01	O ₂	0.0	mg/L	91	
101	10/15/01	O ₂	0.0	mg/L	92	
101	10/15/01	O ₂	0.0	mg/L	93	
101	10/15/01	O ₂	0.0	mg/L	94	
101	10/15/01	O ₂	0.0	mg/L	95	
101	10/15/01	O ₂	0.0	mg/L	96	
101	10/15/01	O ₂	0.0	mg/L	97	
101	10/15/01	O ₂	0.0	mg/L	98	
101	10/15/01	O ₂	0.0	mg/L	99	
101	10/15/01	O ₂	0.0	mg/L	100	

Numerical Water Quality and Contaminant Modeling (EL-22)
 Tidal Fresh Potomac River and Maryland Mainstem
 Sediment-Water Flux: Net sediment-water exchanges of dissolved oxygen and nutrients

STATION	DATE	CORE NO	CORE H2O VOL (mL)	CORE DEPTH (m)	DO SLOPE [mg/(L.min)]	DO FLUX [gO2/(m2.day)]	NUMBER OF CORES	DO FLUX MEAN	DO STANDARD DEVIATION
HGNK	19MAY94	1	2040	0.147	-0.008009	-1.61	3	-1.60	0.15
		2	1940	0.140	-0.009082	-1.74			
		3	1920	0.138	-0.007703	-1.45			
GNCV	19MAY94	1	1980	0.142	-0.008757	-1.66	3	-1.55	0.12
		2	1720	0.124	-0.009387	-1.55			
		3	2160	0.155	-0.007057	-1.43			
MDPT	20MAY94	1	2220	0.160	-0.005485	-1.26	3	-1.50	0.22
		2	1700	0.122	-0.009658	-1.70			
		3	1840	0.132	-0.008049	-1.53			
R 64	21MAY94	1	1550	0.112	-0.004316	-0.69	3	-0.72	0.03
		2	1520	0.109	-0.004733	-0.75			
		3	1560	0.112	-0.004520	-0.73			

MAY 1994 FLUX continued

STATION	CORE NO	NH4 SLOPE	NH4 FLUX	NUMBER OF CORES	NH4 FLUX MEAN	NH4 STANDARD DEVIATION
		[$\mu\text{MN}/(\text{L}\cdot\text{min})$]	[$\mu\text{MN}/(\text{m}^2\cdot\text{hr})$]			
HGNK	1	0.084647	791.8	3	512.1	253.3
	2	0.048007	446.1			
	3	0.030719	298.3			
GNCV	1	0.032397	276.9	3	281.3	32.5
	2	0.042533	315.8			
	3	0.026957	251.3			
MDPT	1	0.008871	85.0	3	96.8	13.0
	2	0.015088	110.7			
	3	0.011926	94.7			
R 64	1	0.034137	228.4	3	181.7	41.9
	2	0.025822	169.4			
	3	0.021890	147.4			

MAY 1994 FLUX continued

STATION	CORE NO	pH SLOPE [-log H/(L.min)]	pH FLUX [-logH/(m2.hr)]	NUMBER OF CORES	pH FLUX MEAN	pH STANDARD DEVIATION
HGK	1	-0.000789	-6.9	2	-6.0	0.0001
	2	-0.000598	-5.0			
	3	NI	NI			
GNCV	1	-0.0005784	-4.9	3	-5.6	0.5983
	2	-0.0007895	-5.9			
	3	-0.0006507	-6.1			
MDPT	1	-0.00055318	-5.3	3	-5.9	0.7491
	2	-0.00091644	-6.7			
	3	-0.00070627	-5.6			
R 64	1	-0.00050575	-3.4	2	-3.1	0.4481
	2	NI	NI			
	3	-0.00040839	-2.8			

MAY 1994 FLUX continued

STATION	CORE NO	NO ₂ + NO ₃ SLOPE	NO ₂ + NO ₃ FLUX	NUMBER OF CORES	NO ₂ + NO ₃ FLUX MEAN	NO ₂ + NO ₃ STANDARD DEVIATION
		[$\mu\text{MN}/(\text{L}\cdot\text{min})$]	[$\mu\text{MN}/(\text{m}^2\cdot\text{hr})$]			
HGK	1	-0.02493	-219.53	3	-318.64	145.689
	2	-0.02991	-250.47			
	3	-0.05863	-485.91			
GNCV	1	-0.021644	-184.99	3	-167.22	16.342
	2	-0.020585	-152.83			
	3	-0.017571	-163.83			
MDPT	1	-0.016738	-181.69	3	-257.74	68.452
	2	-0.035538	-277.09			
	3	-0.037366	-314.43			
R 64	1	-0.011243	-75.22	3	-83.95	9.667
	2	-0.012542	-82.29			
	3	-0.01401	-94.34			

MAY 1994 FLUX continued

STATION	CORE NO	DIP SLOPE	DIP FLUX	NUMBER OF CORES	DIP FLUX MEAN	DIP STANDARD DEVIATION
		[$\mu\text{MP}/(\text{L}\cdot\text{min})$]	[$\mu\text{MP}/(\text{m}^2\cdot\text{hr})$]			
HGK	1	0.000000	0.00	3	1.10	1.91
	2	0.000395	3.31			
	3	0.000000	0.00			
GNCV	1	0.000000	0.00	3	0.00	0.00
	2	0.000000	0.00			
	3	0.000000	0.00			
MDPT	1	NI	NI	2	4.19	0.26
	2	0.000546	4.01			
	3	0.000550	4.37			
R 64	1	0.000690	4.62	3	4.05	0.70
	2	0.000498	3.27			
	3	0.000633	4.26			

MAY 1994 FLUX continued

STATION	CORE NO	SILICATE SLOPE	SILICATE FLUX	NUMBER OF CORES	SILICATE FLUX MEAN	SILICATE STANDARD DEVIATION
		[$\mu\text{MSi}/(\text{L}\cdot\text{min})$]	[$\mu\text{MSi}/(\text{m}^2\cdot\text{hr})$]			
HGK	1	0.07345	647	3	1040	661
	2	0.079978	670			
	3	0.2175	1803			
GNCV	1	0.036147	196	2	99	137
	2	NI	NI			
	3	0.013475	2			
MDPT	1	0.057379	550	3	309	214
	2	0.019124	140			
	3	0.029853	237			
R 64	1	0.041092	275	3	271	14
	2	0.038978	256			
	3	0.042065	283			

MAY 1994 FLUX continued

STATION	CORE NO	TCO2 SLOPE [$\mu\text{MCO}_2/(\text{L}\cdot\text{min})$]	TCO2 FLUX [$\mu\text{MCO}_2/(\text{m}^2\cdot\text{hr})$]	NUMBER OF CORES	TCO2 FLUX MEAN	TCO2 STANDARD DEVIATION
HGK	1	0.985	8924	2	9617	978.84
	2	NI	NI			
	3	1.215	10309			
GNCV	1	0.958	7863	3	6018	2217.22
	2	0.931	6631			
	3	0.419	3558			
MDPT	1	0.182	1647	3	1404	299.62
	2	0.156	1070			
	3	0.198	1497			
R 64	1	0.317	2123	3	1735	342.49
	2	0.225	1475			
	3	0.238	1606			

MAY 1994 FLUX continued

STATION	CORE NO	DOC SLOPE	DOC FLUX	NUMBER OF CORES	DOC FLUX MEAN	DOC STANDARD DEVIATION
		[mg/(L.min)] [gDOC/(m2.day)]				
HGK	1	0.000000	0.00	3	0.00	0.00
	2	0.000000	0.00			
	3	0.000000	0.00			
GNCV	1	0.002380	8.35	3	10.37	2.43
	2	0.002708	9.68			
	3	0.002805	13.07			
MDPT	1	0.000000	0.00	3	0.00	0.00
	2	0.000000	0.00			
	3	0.000000	0.00			
R 64	1	0.000000	0.00	3	0.00	0.00
	2	0.000000	0.00			
	3	0.000000	0.00			

MAY 1994 FLUX continued

STATION	CORE NO	DON SLOPE [$\mu\text{MN}/(\text{L}\cdot\text{min})$]	DON FLUX [$\mu\text{MN}/(\text{m}^2\cdot\text{hr})$]	NUMBER OF CORES	DON FLUX MEAN	DON STANDARD DEVIATION
HGK	1	NI	NI	0	NI	
	2	NI	NI	0		
	3	NI	NI	0		
GNCV	1	NI	NI	0	NI	
	2	NI	NI	0		
	3	NI	NI	0		
MDPT	1	0.01578	151.2	1	151.2	0
	2	NI	NI	0		
	3	NI	NI	0		
R 64	1	NI	NI	0	NI	
	2	NI	NI	0		
	3	NI	NI	0		

MAY 1994 FLUX continued

STATION	CORE NO	DOP SLOPE	DOP FLUX	NUMBER OF CORES	DOP FLUX MEAN	DOP STANDARD DEVIATION
		[μ MP/(L.min)]	[μ MP/(m2.hr)]			
HGNK	1	0	0.00	3	0.00	0.00
	2	0	0.00			
	3	0	0.00			
GNCV	1	-0.00022086	-1.89	2	-2.33	0.63
	2	NI	NI			
	3	-0.00029762	-2.77			
MDPT	1	NI	NI	2	-0.78	4.37
	2	-0.0005275	-3.87			
	3	0.0002907	2.31			
R 64	1	0.00053	0.57	3	-0.82	1.85
	2	0	-2.92			
	3	0.00042667	-0.12			

MAY 1994 FLUX continued

STATION	CORE NO	Fe SLOPE	Fe FLUX	NUMBER OF CORES	Fe FLUX MEAN	Fe STANDARD DEVIATION
		[$\mu\text{MFe}/(\text{L}\cdot\text{min})$]	[$\mu\text{MFe}/(\text{m}^2\cdot\text{hr})$]			
HGK	1	0.006915	61	3	20	35.16
	2	0	0			
	3	0	0			
GNCV	1	0	0	2	1	0.87
	2	0.00016667	1			
	3	NI	NI			
MDPT	1	NI	NI	0	NI	
	2	NI	NI			
	3	NI	NI			
R 64	1	0	0	2	17	24.18
	2	NI	NI			
	3	0.0050783	34			

MAY 1994 FLUX continued

STATION	CORE NO	MN SLOPE [$\mu\text{MMn}/(\text{L}\cdot\text{min})$]	MN FLUX [$\mu\text{MMn}/(\text{m}^2\cdot\text{hr})$]	NUMBER OF CORES	MN FLUX MEAN	MN STANDARD DEVIATION
HGK	1	0.017607	165	3	118	51.54
	2	0.010653	98			
	3	0.00998	92			
GNCV	1	0.0051183	47	3	55	16.85
	2	0.0096983	74			
	3	0.004405	44			
MDPT	1	0.0042378	41	3	41	0.71
	2	0.0056894	42			
	3	0.0052784	42			
R 64	1	0.0025583	17	3	15	2.20
	2	0.0019433	13			
	3	0.0021583	15			

MAY 1994 FLUX continued

STATION	CORE NO	BLANK DO [mg/(L.min)]	BLANK NH4 [μMN/(L.min)]	BLANK pH [-log H/(L.min)]	BLANK NO2+NO3 [μMN/(L.min)]	BLANK DIP [μMP/(L.min)]	BLANK Si(OH)4 [μMSi/(L.min)]
HGNIK	1	-0.00041	-0.00527	0.00000	0.00000	0.00000	0.00000
	2	-0.00041	-0.00527	0.00000	0.00000	0.00000	0.00000
	3	-0.00041	-0.00527	0.00000	0.00000	0.00000	0.00000
GNCV	1	-0.00068	0.00000	0.00000	0.00000	0.00000	0.01326
	2	-0.00068	0.00000	0.00000	0.00000	0.00000	0.01326
	3	-0.00068	0.00000	0.00000	0.00000	0.00000	0.01326
MDPT	1	0.00000	0.00000	0.00000	0.00222	0.00000	0.00000
	2	0.00000	0.00000	0.00000	0.00222	0.00000	0.00000
	3	0.00000	0.00000	0.00000	0.00222	0.00000	0.00000
R 64	1	0.00000	0.00000	0.00000	0.00000	0.00000	0.00000
	2	0.00000	0.00000	0.00000	0.00000	0.00000	0.00000
	3	0.00000	0.00000	0.00000	0.00000	0.00000	0.00000

MAY 1994 FLUX continued

STATION	CORE NO	BLANK	BLANK	BLANK	BLANK	BLANK	BLANK
		TCO2	DOC	DON	DOP	Fe	Mn
		[μMCO_2 /(L.min)]	[mg/(L.min)]	[μMN /(L.min)]	[μMP /(L.min)]	[μMFe /(L.min)]	[μMMn /(L.min)]
HGK	1	-0.02875	0.00000	0.00000	0.00000	0.00000	-0.00108
	2	-0.02875	0.00000	0.00000	0.00000	0.00000	-0.00108
	3	-0.02875	0.00000	0.00000	0.00000	0.00000	-0.00108
GNCV	1	0.03750	0.00140	0.00000	0.00000	0.00000	-0.00033
	2	0.03750	0.00140	0.00000	0.00000	0.00000	-0.00033
	3	0.03750	0.00140	0.00000	0.00000	0.00000	-0.00033
MDPT	1	0.00992	0.00000	0.00000	0.00000	0.00000	0.00000
	2	0.00992	0.00000	0.00000	0.00000	0.00000	0.00000
	3	0.00992	0.00000	0.00000	0.00000	0.00000	0.00000
R 64	1	0.00000	0.00000	0.00000	0.00044	0.00000	0.00000
	2	0.00000	0.00000	0.00000	0.00044	0.00000	0.00000
	3	0.00000	0.00000	0.00000	0.00044	0.00000	0.00000

Numerical Water Quality and Contaminant Modeling (EL-22)
 Tidal Fresh Potomac River and Maryland Mainstem
 Sediment-Water Flux: Net sediment-water exchanges of dissolved oxygen and nutrients

STATION	DATE	CORE NO	CORE H2O VOL (mL)	CORE DEPTH (m)	DO SLOPE [mg/(L.min)]	DO FLUX [gO2/(m2.day)]	NUMBER OF CORES	DO FLUX MEAN	DO STANDARD DEVIATION
HGK	12JULY94	1	2020	0.145	-0.004316	-0.90	3	-0.99	0.08
		2	2160	0.155	-0.004733	-1.06			
		3	2140	0.154	-0.004520	-1.00			
GNCV	12JULY94	1	1680	0.121	-0.010427	-1.38	3	-1.61	0.21
		2	1670	0.120	-0.012402	-1.71			
		3	1760	0.127	-0.012135	-1.75			
MDPT	13JULY94	1	2060	0.148	-0.008839	-1.82	3	-1.73	0.32
		2	2000	0.144	-0.006931	-1.37			
		3	1820	0.131	-0.010842	-1.99			
R 64	14JULY94	1	2090	0.150	-0.002227	-0.09	3	-0.02	0.13
		2	2200	0.158	-0.001267	0.13			
		3	2140	0.154	-0.002333	-0.11			

JULY 1994 FLUX continued

STATION	CORE NO	NH4 SLOPE	NH4 FLUX	NUMBER OF CORES	NH4 FLUX MEAN	NH4 STANDARD DEVIATION
		[$\mu\text{MN}/(\text{L}\cdot\text{min})$]	[$\mu\text{MN}/(\text{m}^2\cdot\text{hr})$]			
HGK	1	0.034137	297.7	3	246.9	48.0
	2	0.025822	240.8			
	3	0.021890	202.2			
GNCV	1	0.030010	203.0	3	228.8	24.0
	2	0.036738	250.2			
	3	0.032723	233.2			
MDPT	1	0.061140	543.7	3	554.8	437.0
	2	0.014313	123.6			
	3	0.126940	997.3			
R 64	1	0.032635	294.4	3	296.0	58.0
	2	0.037355	354.7			
	3	0.025857	238.9			

JULY 1994 FLUX continued

STATION	CORE NO	pH SLOPE	pH FLUX	NUMBER OF CORES	pH FLUX MEAN	pH STANDARD DEVIATION
		$[-\log H/(L.min)]$	$[-\log H/(m^2.hr)]$			
HGK	1	-0.0015098	-13.2	3	-14.7	1.4750
	2	-0.001726	-16.1			
	3	-0.0016172	-14.9			
GNCV	1	-0.0011029	-8.0	3	-10.9	2.5266
	2	-0.0016941	-12.2			
	3	-0.001648	-12.5			
MDPT	1	-0.00061646	-5.5	3	-5.3	1.1011
	2	-0.00048123	-4.2			
	3	-0.00080701	-6.3			
R 64	1	0.00075667	6.8	3	7.1	1.1125
	2	0.00064833	6.2			
	3	0.00090167	8.3			

JULY 1994 FLUX continued

STATION	CORE NO	NO ₂ + NO ₃ SLOPE	NO ₂ + NO ₃ FLUX	NUMBER OF CORES	NO ₂ + NO ₃ FLUX MEAN	NO ₂ + NO ₃ STANDARD DEVIATION
		[$\mu\text{MN}/(\text{L}\cdot\text{min})$]	[$\mu\text{MN}/(\text{m}^2\cdot\text{hr})$]			
HGK	1	-0.057894	-416.4	3	-342.5	64.11
	2	-0.04326	-308.8			
	3	-0.042853	-302.2			
GNCV	1	-0.0061487	-44.6	3	-48.7	5.77
	2	-0.0076662	-55.3			
	3	-0.006072	-46.1			
MDPT	1	NI	NI	0	NI	
	2	NI	NI			
	3	NI	NI			
R 64	1	NI	NI	0	NI	
	2	NI	NI			
	3	NI	NI			

JULY 1994 FLUX continued

STATION	CORE NO	DIP SLOPE	DIP FLUX	NUMBER OF CORES	DIP FLUX MEAN	DIP STANDARD DEVIATION
		[$\mu\text{MP}/(\text{L}\cdot\text{min})$]	[$\mu\text{MP}/(\text{m}^2\cdot\text{hr})$]			
HGK	1	0.000588	5.1	2	5.49	0.51
	2	NI	N			
	3	0.000633	5.8			
GNCV	1	0.001916	13.9	1	13.89	0.00
	2	NI	N			
	3	NI	N			
MDPT	1	-0.001082	-9.6	1	-9.62	0.00
	2	NI	N			
	3	NI	N			
R 64	1	0.004653	42.0	3	44.39	3.51
	2	0.005098	48.4			
	3	0.004632	42.8			

JULY 1994 FLUX continued

STATION	CORE NO	SILICATE SLOPE	SILICATE FLUX	NUMBER OF CORES	SILICATE FLUX MEAN	SILICATE STANDARD DEVIATION
		[$\mu\text{MSi}/(\text{L}\cdot\text{min})$]	[$\mu\text{MSi}/(\text{m}^2\cdot\text{hr})$]			
HGK	1	0.055057	-124.9	3	-133.55	104
	2	0.065698	-34.3			
	3	0.043237	-241.5			
GNCV	1	0.018037	130.8	3	117.63	26
	2	0.01864	134.4			
	3	0.011547	87.7			
MDPT	1	NI	NI	2	517.49	280
	2	0.037028	319.7			
	3	0.091053	715.3			
R 64	1	0.041295	350.3	3	383.33	89
	2	0.03566	315.3			
	3	0.054898	484.4			

JULY 1994 FLUX continued

STATION	CORE NO	TCO2 SLOPE [$\mu\text{MCO}_2/(\text{L}\cdot\text{min})$]	TCO2 FLUX [$\mu\text{MCO}_2/(\text{m}^2\cdot\text{hr})$]	NUMBER OF CORES	TCO2 FLUX MEAN	TCO2 STANDARD DEVIATION
HGK	1	0.317290	2767	3	2355	360.14
	2	0.224850	2096			
	3	0.238470	2203			
GNCV	1	0.814750	5656	3	5467	165.40
	2	0.777510	5354			
	3	0.744050	5389			
MDPT	1	0.205690	1970	3	2784	705.83
	2	0.357140	3220			
	3	0.386750	3163			
R 64	1	0.125540	1735	3	1953	556.08
	2	0.205340	2585			
	3	0.099672	1538			

JULY 1994 FLUX continued

STATION	CORE NO	DOC SLOPE [mg/(L.min)]	DOC FLUX [gDOC/(m2.day)]	NUMBER OF CORES	DOC FLUX MEAN	DOC STANDARD DEVIATION
HGK	1	0	0	3	8.12058993	7.23
	2	0.0014867	13.8616058			
	3	0.0011367	10.500164			
GNCV	1	0.001605	11.6391367	3	13.4477813	14.44
	2	0	0			
	3	0.0037783	28.7042072			
MDPT	1	-0.00038071	3.43919223	3	5.36477669	1.69
	2	0	6.62572662			
	3	0	6.02941122			
R 64	1	0.00030833	4.76637281	3	2.96260388	1.56
	2	0	2.08920863			
	3	0	2.03223022			

JULY 1994 FLUX continued

STATION	CORE NO	DON SLOPE ($\mu\text{MN}/\text{min}$)	DON FLUX [$\mu\text{MN}/(\text{m}^2.\text{hr})$]	NUMBER OF CORES	DON FLUX MEAN	DON STANDARD DEVIATION
HGK	1	-0.022052	-192.280748	2	-172.091568	28.6
	2	-0.016292	-151.902388			
	3	NI	NI			
GNCV	1	NI	NI	0	NI	
	2	NI	NI			
	3	NI	NI			
MDPT	1	NI	NI	0	NI	
	2	NI	NI			
	3	NI	NI			
R 64	1	NI	NI	0	NI	
	2	NI	NI			
	3	NI	NI			

JULY 1994 FLUX continued

STATION	CORE NO	DOP SLOPE	DOP FLUX	NUMBER OF CORES	DOP FLUX MEAN	DOP STANDARD DEVIATION
		[$\mu\text{MP}/(\text{L}\cdot\text{min})$][$\mu\text{MP}/(\text{m}^2\cdot\text{hr})$]				
HGK	1	0.002107	18.3718273	2	9.18591367	12.99
	2	0	0			
	3	NI	NI			
GNCV	1	NI	NI	0	NI	
	2	NI	NI			
	3	NI	NI			
MDPT	1	NI	NI	0	NI	
	2	NI	NI			
	3	NI	NI			
R 64	1	0.001275	11.502518	1	11.502518	0.00
	2	NI	NI			
	3	NI	NI			

JULY 1994 FLUX continued

STATION	CORE NO	Fe SLOPE [$\mu\text{MFe}/(\text{L}\cdot\text{min})$]	Fe FLUX [$\mu\text{MFe}/(\text{m}^2\cdot\text{hr})$]	NUMBER OF CORES	Fe FLUX MEAN	Fe STANDARD DEVIATION
HGNK	1	-0.0073167	-18.18	3	-15.5578273	6.69
	2	-0.006085	-7.9559482			
	3	-0.007455	-20.5375338			
GNCV	1	-0.006805	-26.2515108	3	-28.8351683	2.25
	2	-0.0074	-30.3843885			
	3	-0.0071167	-29.8696058			
MDPT	1	-0.0050633	-19.6070504	3	-27.6483367	40.52
	2	-0.0019033	8.24460432			
	3	-0.01197	-71.582564			
R 64	1	-0.002095	12.0591496	3	12.2706201	20.21
	2	0	32.5888058			
	3	-0.00428	-7.83609496			

JULY 1994 FLUX continued

STATION	CORE NO	MN SLOPE	MN FLUX	NUMBER OF CORES	MN FLUX MEAN	MN STANDARD DEVIATION
		[$\mu\text{MMn}/(\text{L}\cdot\text{min})$][$\mu\text{MMn}/(\text{m}^2\cdot\text{hr})$]				
HGK	1	0.017352	151.299453	3	174.408518	28.13
	2	0.02793	260.412086			
	3	0.012072	111.514014			
GNCV	1	0	0	3	-1.71832863	5.71
	2	-0.0011224	-8.09096978			
	3	0.00038646	2.93598388			
MDPT	1	0.028147	250.285554	3	257.452115	145.42
	2	0.013408	115.752518			
	3	0.05172	406.318273			
R 64	1	0	0	3	0	0.00
	2	0	0			
	3	0	0			

JULY 1994 FLUX continued

STATION	CORE NO	BLANK DO [mg/(L.min)]	BLANK NH4 [μ MN/(L.min)]	BLANK pH [-log H/(L.min)]	BLANK NO2+NO3 [μ MN/(L.min)]	BLANK DIP [μ MP/(L.min)]	BLANK Si(OH)4 [μ MSi/(L.min)]
HGK	1	0.00000	0.00000	0.00000	-0.01014	0.00000	0.06938
	2	0.00000	0.00000	0.00000	-0.01014	0.00000	0.06938
	3	0.00000	0.00000	0.00000	-0.01014	0.00000	0.06938
GNCV	1	-0.00251	0.00202	0.00000	0.00000	0.00000	0.00000
	2	-0.00251	0.00202	0.00000	0.00000	0.00000	0.00000
	3	-0.00251	0.00202	0.00000	0.00000	0.00000	0.00000
MDPT	1	-0.00030	0.00000	0.00000	0.00357	0.00000	0.00000
	2	-0.00030	0.00000	0.00000	0.00357	0.00000	0.00000
	3	-0.00030	0.00000	0.00000	0.00357	0.00000	0.00000
R 64	1	-0.00183	0.00000	0.00000	0.00000	0.00000	0.00246
	2	-0.00183	0.00000	0.00000	0.00000	0.00000	0.00246
	3	-0.00183	0.00000	0.00000	0.00000	0.00000	0.00246

JULY 1994 FLUX continued

STATION	CORE NO	BLANK	BLANK	BLANK	BLANK	BLANK	BLANK
		TCO2	DOC	DON	DOP	Fe	Mn
		[$\mu\text{MCO}_2/(\text{L}\cdot\text{min})$]	[$\text{mg}/(\text{L}\cdot\text{min})$]	[$\mu\text{MN}/(\text{L}\cdot\text{min})$]	[$\mu\text{MP}/(\text{L}\cdot\text{min})$]	[$\mu\text{MFe}/(\text{L}\cdot\text{min})$]	[$\mu\text{MMn}/(\text{L}\cdot\text{min})$]
HGK	1	0.00000	0.00000	0.00000	0.00000	-0.00523	0.00000
	2	0.00000	0.00000	0.00000	0.00000	-0.00523	0.00000
	3	0.00000	0.00000	0.00000	0.00000	-0.00523	0.00000
GNCV	1	0.03474	0.00000	0.00000	0.00000	-0.00319	0.00000
	2	0.03474	0.00000	0.00000	0.00000	-0.00319	0.00000
	3	0.03474	0.00000	0.00000	0.00000	-0.00319	0.00000
MDPT	1	-0.01583	-0.00077	0.00000	0.00000	-0.00286	0.00000
	2	-0.01583	-0.00077	0.00000	0.00000	-0.00286	0.00000
	3	-0.01583	-0.00077	0.00000	0.00000	-0.00286	0.00000
R 64	1	-0.06682	-0.00022	0.00000	0.00000	-0.00343	0.00000
	2	-0.06682	-0.00022	0.00000	0.00000	-0.00343	0.00000
	3	-0.06682	-0.00022	0.00000	0.00000	-0.00343	0.00000

Numerical Water Quality and Contaminant Modeling (EL-22)
 Tidal Fresh Potomac River and Maryland Mainstem
 Sediment-Water Flux: Net sediment-water exchanges of dissolved oxygen and nutrients

STATION	DATE	CORE NO	CORE H2O VOL (mL)	CORE DEPTH (m)	DO SLOPE [mg/(L.min)]	DO FLUX [gO2/(m2.day)]	NUMBER OF CORES	DO FLUX MEAN	DO STANDARD DEVIATION
HGK	9AUG94	1	1900	0.137	-0.0088933	-1.4462417	3	-1.437	0.17
		2	1910	0.137	-0.0079333	-1.2638978			
		3	1960	0.141	-0.0094244	-1.5997526			
GNCV	9AUG94	1	2600	0.187	-0.010272	-2.2439758	3	-2.038	0.53
		2	2000	0.144	-0.0088753	-1.4367471			
		3	2500	0.18	-0.011332	-2.4322014			
MDPT	10AUG94	1	1960	0.141	-0.0046819	-0.9506615	3	-1.095	0.36
		2	2020	0.145	-0.0039486	-0.8263085			
		3	2060	0.148	-0.0070698	-1.5087665			
R 64	11AUG94	1	2040	0.147	-0.00011053	0.0127035	3	9E-04	0.01
		2	2120	0.153	-0.00017669	-0.0013287			
		3	2080	0.15	-0.00021136	-0.0087744			

AUGUST 1994 FLUX continued

STATION	CORE NO	NH4 SLOPE	NH4 FLUX	NUMBER OF CORES	NH4 FLUX MEAN	NH4 STANDARD DEVIATION
		[$\mu\text{MN}/(\text{L}\cdot\text{min})$]	[$\mu\text{MN}/(\text{m}^2\cdot\text{hr})$]			
HGK	1	0.092183	756.033237	3	802.820403	125.97
	2	0.11468	945.491223			
	3	0.083558	706.936748			
GNCV	1	0.043728	472.305151	3	422.317353	217.24
	2	0.023009	184.44259			
	3	0.05819	610.204317			
MDPT	1	0.028222	152.304691	3	315.338475	259.22
	2	0.030802	179.463194			
	3	0.079298	614.24754			
R 64	1	0.024223	213.301813	3	214.438158	16.59
	2	0.021686	198.450302			
	3	0.025791	231.56236			

AUGUST 1994 FLUX continued

STATION	CORE NO	pH SLOPE	pH FLUX	NUMBER OF CORES	pH FLUX MEAN	pH STANDARD DEVIATION
		$[-\log H/(L.min)]$	$[-\log H/(m^2.hr)]$			
HGNK	1	-0.00097749	-8.01682446	3	-9.21625755	1.0864
	2	-0.0012292	-10.1342676			
	3	-0.0011226	-9.49768058			
GNCV	1	-0.0025089	-21.0249842	3	-15.7174072	8.0927
	2	-0.0013772	-6.40299281			
	3	-0.0024633	-19.7242446			
MDPT	1	-0.00054979	-4.65146072	3	-1.55048691	2.6855
	2	0	0			
	3	0	0			
R 64	1	0.00028363	0.41343022	3	0.38597871	0.0841
	2	0.00028617	0.45288691			
	3	0.00026916	0.29161899			

AUGUST 1994 FLUX continued

STATION	CORE NO	NO ₂ + NO ₃ SLOPE	NO ₂ + NO ₃ FLUX	NUMBER OF CORES	NO ₂ + NO ₃ FLUX MEAN	NO ₂ + NO ₃ STANDARD DEVIATION
		[$\mu\text{MN}/(\text{L}\cdot\text{min})$][$\mu\text{MN}/(\text{m}^2\cdot\text{hr})$]				
HGK	1	-0.022315	-183.015108	2	-191.38295	11.83
	2	NI	NI			
	3	-0.02361	-199.750791			
GNCV	1	-0.0069162	-77.6206619	2	-83.8410863	8.80
	2	NI	NI			
	3	-0.0083457	-90.0615108			
MDPT	1	0.0036633	30.9930993	3	21.6671597	37.77
	2	0.0061817	53.9008662			
	3	-0.0022371	-19.8924863			
R 64	1	NI	NI	0	NI	
	2	NI	NI			
	3	NI	NI			

AUGUST 1994 FLUX continued

STATION	CORE NO	DIP SLOPE	DIP FLUX	NUMBER OF CORES	DIP FLUX MEAN	DIP STANDARD DEVIATION
		[μ MP/(L.min)]	[μ MP/(m ² .hr)]			
HGK	1	0	0	3	0.2724646	2.07
	2	-0.00012833	-1.05803007			
	3	0.00022167	1.87542388			
GNCV	1	NI	NI	1	6.2573741	0.00
	2	NI	NI			
	3	0.00057985	6.2573741			
MDPT	1	NI	NI	1	0	0.00
	2	NI	NI			
	3	0	0			
R 64	1	0.0038619	35.1749422	3	32.0919908	3.53
	2	0.0034576	32.8545704			
	3	0.0030134	28.2464599			

AUGUST 1994 FLUX continued

STATION	CORE NO	SILICATE SLOPE	SILICATE FLUX	NUMBER OF CORES	SILICATE FLUX MEAN	SILICATE STANDARD DEVIATION
		[$\mu\text{MSi}/(\text{L}\cdot\text{min})$]	[$\mu\text{MSi}/(\text{m}^2\cdot\text{hr})$]			
HGNK	1	0.028155	230.911511	3	225.948417	63
	2	0.032483	267.809482			
	3	0.021172	179.124259			
GNCV	1	0.026194	293.975827	3	227.47036	133
	2	0.01159	100.057554			
	3	0.026723	288.377698			
MDPT	1	0.034388	290.937324	3	559.452345	164
	2	0.06625	577.661871			
	3	0.091065	809.757842			
R 64	1	0.046489	409.370763	3	353.132489	100
	2	0.043254	395.820777			
	3	0.028313	254.205928			

AUGUST 1994 FLUX continued

STATION	CORE NO	TCO2 SLOPE	TCO2 FLUX	NUMBER OF CORES	TCO2 FLUX MEAN	TCO2 STANDARD DEVIATION
		[$\mu\text{MCO}_2/(\text{L}\cdot\text{min})$]	[$\mu\text{MCO}_2/(\text{m}^2\cdot\text{hr})$]			
HGK	1	0.63967	5246.21439	3	5324.30029	508.61
	2	0.71167	5867.43755			
	3	0.57435	4859.24892			
GNCV	1	0.81757	9175.60576	3	7660.92374	2795.39
	2	0.51373	4435.07914			
	3	0.86848	9372.08633			
MDPT	1	0.18288	1193.84305	3	2692.97462	1393.71
	2	0.49471	3949.3674			
	3	0.37192	2935.71341			
R 64	1	0.21509	1894.02993	3	1726.53122	145.31
	2	0.18045	1651.31223			
	3	0.18202	1634.25151			

AUGUST 1994 FLUX continued

STATION	CORE NO	DOC SLOPE	DOC FLUX	NUMBER OF CORES	DOC FLUX MEAN	DOC STANDARD DEVIATION
		[mg/(L.min)][gDOC/(m2.day)]				
HGK	1	0.000855	7.01	3	2.34	4.05
	2	0.000000	0.00			
	3	0.000000	0.00			
GNCV	1	0.000000	0.00	3	5.12	8.87
	2	0.000000	0.00			
	3	0.001423	15.36			
MDPT	1	0.000000	0.00	3	0.00	0.00
	2	0.000000	0.00			
	3	0.000000	0.00			
R 64	1	0.000000	0.00	3	0.00	0.00
	2	0.000000	0.00			
	3	0.000000	0.00			

AUGUST 1994 FLUX continued

AUGUST 1994 FLUX continued

STATION	CORE NO	DON SLOPE	DON FLUX	NUMBER OF CORES	DON FLUX MEAN	DON STANDARD DEVIATION
		[$\mu\text{MN}/(\text{L}\cdot\text{min})$]	[$\mu\text{MN}/(\text{m}^2\cdot\text{hr})$]			
HGK	1	NI	NI	0	NI	
	2	NI	NI			
	3	NI	NI			
GNCV	1	NI	NI	0	NI	
	2	NI	NI			
	3	NI	NI			
MDPT	1	NI	NI	0	NI	
	2	NI	NI			
	3	NI	NI			
R 64	1	0.015829	139.39	2	186.83	67.1
	2	0.025601	234.28			
	3	NI	NI			

AUGUST 1994 FLUX continued

STATION	CORE NO	DOP SLOPE	DOP FLUX	NUMBER OF CORES	DOP FLUX MEAN	DOP STANDARD DEVIATION
		[$\mu\text{MP}/(\text{L}\cdot\text{min})$]	[$\mu\text{MP}/(\text{m}^2\cdot\text{hr})$]			
HGK	1	0.00013667	1.12	3	0.37	0.65
	2	0	0.00			
	3	0	0.00			
GNCV	1	NI	NI	1	4.70	0.00
	2	NI	NI			
	3	0.00043589	4.70			
MDPT	1	0.0010317	8.73	2	5.71	4.27
	2	0.00030848	2.69			
	3	NI	NI			
R 64	1	0.036043	317.39	3	390.57	65.75
	2	0.04859	444.65			
	3	0.04563	409.69			

AUGUST 1994 FLUX continued

STATION	CORE NO	Fe SLOPE	Fe FLUX	NUMBER OF CORES	Fe FLUX MEAN	Fe STANDARD DEVIATION
		[$\mu\text{MFe}/(\text{L}\cdot\text{min})$]	[$\mu\text{MFe}/(\text{m}^2\cdot\text{hr})$]			
HGNK	1	-0.005035	-10	3	-16	5.62
	2	-0.0062167	-20			
	3	-0.00614	-20			
GNCV	1	-0.0060751	-37	3	-29	9.32
	2	-0.0049432	-18			
	3	-0.0056639	-31			
MDPT	1	-0.0050133	-24	3	-22	17.57
	2	-0.0064917	-38			
	3	-0.0024867	-3			
R 64	1	0	0	3	-5	17.50
	2	-0.0026483	-24			
	3	0.0010855	10			

AUGUST 1994 FLUX continued

STATION	CORE NO	MN SLOPE	MN FLUX	NUMBER OF CORES	MN FLUX MEAN	MN STANDARD DEVIATION
		[$\mu\text{MMn}/(\text{L}\cdot\text{min})$]	[$\mu\text{MMn}/(\text{m}^2\cdot\text{hr})$]			
HGK	1	0.0052817	43	3	55	6.19
	2	0.010598	87			
	3	0.004085	35			
GNCV	1	0.0026099	29	3	21	17.00
	2	0.00018484	2			
	3	0.0030125	33			
MDPT	1	0.016055	137	3	170	44.78
	2	0.017292	152			
	3	0.02471	221			
R 64	1	-0.035297	146	3	182	305.90
	2	-0.063332	-105			
	3	0.004240	504			

AUGUST 1994 FLUX continued

STATION	CORE NO	BLANK DO [mg/(L.min)]	BLANK NH4 [μMN/(L.min)]	BLANK pH [-log H/(L.min)]	BLANK NO2+NO3 [μMN/(L.min)]	BLANK DIP [μMP/(L.min)]	BLANK Si(OH)4 [μMSi/(L.min)]
HGK	1	-0.0015	0.0000	0.0000	0.0000	0.0000	0.0000
	2	-0.0015	0.0000	0.0000	0.0000	0.0000	0.0000
	3	-0.0015	0.0000	0.0000	0.0000	0.0000	0.0000
GNCV	1	-0.0019	0.0016	-0.0006	0.0000	0.0000	0.0000
	2	-0.0019	0.0016	-0.0006	0.0000	0.0000	0.0000
	3	-0.0019	0.0016	-0.0006	0.0000	0.0000	0.0000
MDPT	1	0.0000	0.0102	0.0000	0.0000	0.0000	0.0000
	2	0.0000	0.0102	0.0000	0.0000	0.0000	0.0000
	3	0.0000	0.0102	0.0000	0.0000	0.0000	0.0000
R 64	1	-0.0002	0.0000	0.0002	0.0000	-0.0001	0.0000
	2	-0.0002	0.0000	0.0002	0.0000	-0.0001	0.0000
	3	-0.0002	0.0000	0.0002	0.0000	-0.0001	0.0000

AUGUST 1994 FLUX continued

STATION	CORE NO	BLANK	BLANK	BLANK	BLANK	BLANK	BLANK
		TCO2	DOC	DON	DOP	Fe	Mn
		[μMCO_2 /(L.min)]	[mg/(L.min)]	[μMN /(L.min)]	[μMP /(L.min)]	[μMFe /(L.min)]	[μMMn /(L.min)]
HGK	1	0.0000	0.0000	0.0000	0.0000	-0.0038	0.0000
	2	0.0000	0.0000	0.0000	0.0000	-0.0038	0.0000
	3	0.0000	0.0000	0.0000	0.0000	-0.0038	0.0000
GNCV	1	0.0000	0.0000	0.0000	0.0000	-0.0028	0.0000
	2	0.0000	0.0000	0.0000	0.0000	-0.0028	0.0000
	3	0.0000	0.0000	0.0000	0.0000	-0.0028	0.0000
MDPT	1	0.0418	0.0000	0.0000	0.0000	-0.0022	-0.0002
	2	0.0418	0.0000	0.0000	0.0000	-0.0022	-0.0002
	3	0.0418	0.0000	0.0000	0.0000	-0.0022	-0.0002
R 64	1	0.0000	0.0000	0.0000	0.0000	0.0000	-0.0519
	2	0.0000	0.0000	0.0000	0.0000	0.0000	-0.0519
	3	0.0000	0.0000	0.0000	0.0000	0.0000	-0.0519

Numerical Water Quality and Contaminant Modeling (EL-22)

Tidal Fresh Potomac River and Maryland Mainstem

Sediment-Water Flux: Net sediment-water exchanges of dissolved oxygen and nutrients

STATION	DATE	CORE NO	CORE H2O VOL (mL)	CORE DEPTH (m)	DO SLOPE [mg/(L.min)]	DO FLUX [gO2/(m2.day)]	NUMBER OF CORES	DO FLUX MEAN	DO STANDARD DEVIATION
HGK	13OCT94	1	1880	0.135	-0.005906	-1.15	3	-1.03	0.11
		2	1810	0.130	-0.005068	-0.95			
		3	2080	0.150	-0.004559	-0.98			
GNCV	13OCT94	1	2000	0.144	-0.005638	-1.00	3	-1.05	0.11
		2	1960	0.141	-0.006605	-1.18			
		3	2000	0.144	-0.005555	-0.98			
MDPT	14OCT94	1	1980	0.142	-0.004002	-0.78	3	-0.69	0.10
		2	1820	0.131	-0.003324	-0.59			
		3	1960	0.141	-0.003615	-0.69			
R 64	17OCT94	1	1850	0.133	-0.005625	-1.13	3	-1.32	0.23
		2	2170	0.156	-0.005280	-1.25			
		3	1800	0.129	-0.008171	-1.57			

OCTOBER 1994 FLUX continued

STATION	CORE NO	NH4 SLOPE	NH4 FLUX	NUMBER OF CORES	NH4 FLUX MEAN	NH4 STANDARD DEVIATION
		[$\mu\text{MN}/(\text{L}\cdot\text{min})$]	[$\mu\text{MN}/(\text{m}^2\cdot\text{hr})$]			
HGK	1	0.064022	519.5	3	536.4	36.33
	2	0.065477	511.6			
	3	0.064387	578.1			
GNCV	1	0.012189	105.2	3	148.1	81.41
	2	0.028597	241.9			
	3	0.011237	97.0			
MDPT	1	0.016607	141.9	3	130.7	39.82
	2	0.020828	163.6			
	3	0.010215	86.4			
R 64	1	0.039488	315.3	3	358.5	37.71
	2	0.041083	384.8			
	3	0.048325	375.5			

OCTOBER 1994 FLUX continued

STATION	CORE NO	pH SLOPE [-log H/(L.min)]	pH FLUX [-log H/(m2.hr)]	NUMBER OF CORES	pH FLUX MEAN	pH STANDARD DEVIATION
HGK	1	NI	NI	2	-5.6	0.1100
	2	-0.00070314	-5.5			
	3	-0.00062919	-5.6			
GNCV	1	-0.0011411	-9.9	2	-11.9	2.9267
	2	-0.0016536	-14.0			
	3	NI	NI			
MDPT	1	-0.00048003	-4.1	3	-2.3	2.1100
	2	0	0.0			
	3	-0.00034361	-2.9			
R 64	1	-0.00062788	-5.0	3	-3.4	2.9618
	2	-0.00055928	-5.2			
	3	0	0.0			

OCTOBER 1994 FLUX continued

STATION	CORE NO	NO ₂ + NO ₃ SLOPE	NO ₂ + NO ₃ FLUX	NUMBER OF CORES	NO ₂ + NO ₃ FLUX MEAN	NO ₂ + NO ₃ STANDARD DEVIATION
		[$\mu\text{MN}/(\text{L}\cdot\text{min})$]	[$\mu\text{MN}/(\text{m}^2\cdot\text{hr})$]			
HGK	1	-0.075699	-298.5	3	13.9	274.23
	2	-0.011378	215.2			
	3	-0.02501	124.9			
GNCV	1	-0.0092183	-79.6	3	-114.6	60.85
	2	-0.021854	-184.9			
	3	-0.009199	-79.4			
MDPT	1	0.005074	43.4	2	-46.8	127.55
	2	-0.01744	-137.0			
	3	NI	NI			
R 64	1	-0.00089804	-7.2	3	-6.5	2.34
	2	-0.00041631	-3.9			
	3	-0.0010854	-8.4			

OCTOBER 1994 FLUX continued

STATION	CORE NO	DIP SLOPE [$\mu\text{MP}/(\text{L}\cdot\text{min})$]	DIP FLUX [$\mu\text{MP}/(\text{m}^2\cdot\text{hr})$]	NUMBER OF CORES	DIP FLUX MEAN	DIP STANDARD DEVIATION
HGK	1	0.000000	0.0	3	0.00	0.00
	2	0.000000	0.0			
	3	0.000000	0.0			
GNCV	1	0.000000	0.0	3	0.77	1.64
	2	0.000274	2.3			
	3	0.000000	0.0			
MDPT	1	0.000000	0.0	3	0.00	0.00
	2	0.000000	0.0			
	3	0.000000	0.0			
R 64	1	0.000413	3.3	3	10.10	5.91
	2	0.001497	14.0			
	3	0.001670	13.0			

OCTOBER 1994 FLUX continued

STATION	CORE NO	SILICATE SLOPE	SILICATE FLUX	NUMBER OF CORES	SILICATE FLUX MEAN	SILICATE STANDARD DEVIATION
		[$\mu\text{MSi}/(\text{L}\cdot\text{min})$]	[$\mu\text{MSi}/(\text{m}^2\cdot\text{hr})$]			
HGK	1	0.015614	-805.7	2	-891.67	122
	2	NI	NI			
	3	0.0060144	-977.6			
GNCV	1	NI	NI	2	114.94	252
	2	0.034608	292.8			
	3	-0.0072879	-62.9			
MDPT	1	0.016432	140.4	3	729.72	1041
	2	0.24595	1932.2			
	3	0.013771	116.5			
R 64	1	0.033902	112.4	3	158.02	19
	2	0.043627	222.9			
	3	0.037682	138.7			

OCTOBER 1994 FLUX continued

STATION	CORE NO	TCO2 SLOPE	TCO2 FLUX	NUMBER OF CORES	TCO2 FLUX MEAN	TCO2 STANDARD DEVIATION
		[$\mu\text{MCO}_2/(\text{L}\cdot\text{min})$]	[$\mu\text{MCO}_2/(\text{m}^2\cdot\text{hr})$]			
HGK	1	0.276510	993	3	1447	397.20
	2	0.375610	1731			
	3	0.334330	1618			
GNCV	1	0.474470	4096	3	4772	1118.90
	2	0.716730	6064			
	3	0.481520	4157			
MDPT	1	0.215830	425	3	2138	2753.33
	2	0.842610	5314			
	3	0.246080	676			
R 64	1	0.427830	3416	3	3663	555.31
	2	0.458920	4299			
	3	0.421280	3273			

OCTOBER 1994 FLUX continued

STATION	CORE NO	DOC SLOPE	DOC FLUX	NUMBER OF CORES	DOC FLUX MEAN	DOC STANDARD DEVIATION
		[mg/(L.min)][gDOC/(m2.day)]				
HGK	1	0.000000	2.97	3	3.03	0.22
	2	0.000000	2.85			
	3	0.000000	3.28			
GNCV	1	0.000000	0.00	3	0.00	0.00
	2	0.000000	0.00			
	3	0.000000	0.00			
MDPT	1	0.000000	0.00	3	-2.27	3.93
	2	-0.000866	-6.80			
	3	0.000000	0.00			
R 64	1	-0.015773	-125.96	3	-41.99	72.72
	2	0.000000	0.00			
	3	0.000000	0.00			

OCTOBER 1994 FLUX continued

STATION	CORE NO	DON SLOPE [$\mu\text{MN}/(\text{L} \cdot \text{min})$]	DON FLUX [$\mu\text{MN}/(\text{m}^2 \cdot \text{hr})$]	NUMBER OF CORES	DON FLUX MEAN	DON STANDARD DEVIATION
HGK	1	0.060296	489.31	2	311.04	252.115169
	2	NI	NI			
	3	0.014787	132.76			
GNCV	1	NI	NI	0	NI	
	2	NI	NI			
	3	NI	NI			
MDPT	1	NI	NI	1	-99.41	0
	2	-0.012654	-99.41			
	3	NI	NI			
R 64	1	-0.0064273	-51.33	1	-51.33	0
	2	NI	NI			
	3	NI	NI			

OCTOBER 1994 FLUX continued

STATION	CORE NO	DOP SLOPE	DOP FLUX	NUMBER OF CORES	DOP FLUX MEAN	DOP STANDARD DEVIATION
		[$\mu\text{MP}/(\text{L}\cdot\text{min})$]	[$\mu\text{MP}/(\text{m}^2\cdot\text{hr})$]			
HGNK	1	0	0.00	3	0.00	0.00
	2	0	0.00			
	3	0	0.00			
GNCV	1	0.00034144	2.95	1	2.95	0.00
	2	NI	NI			
	3	NI	NI			
MDPT	1	0.00064537	5.52	1	5.52	0.00
	2	NI	NI			
	3	NI	NI			
R 64	1	-0.00024185	-0.43	3	0.33	1.00
	2	-0.00019279	-0.04			
	3	0	1.46			

OCTOBER 1994 FLUX continued

STATION	CORE NO	Fe SLOPE [$\mu\text{MFe}/(\text{L}\cdot\text{min})$]	Fe FLUX [$\mu\text{MFe}/(\text{m}^2\cdot\text{hr})$]	NUMBER OF CORES	Fe FLUX MEAN	Fe STANDARD DEVIATION
HGK	1	-0.0054496	-5	2	4	13.99
	2	-0.0029436	14			
	3	NI	NI			
GNCV	1	NI	NI	2	43	14.25
	2	0.0032867	53			
	3	0.00082667	33			
MDPT	1	-0.0021733	6	3	7	8.57
	2	-0.0029239	0			
	3	-0.00091397	16			
R 64	1	-0.02779	-209	3	-262	46.95
	2	-0.033605	-300			
	3	-0.037072	-276			

OCTOBER 1994 FLUX continued

STATION	CORE NO	MN SLOPE [$\mu\text{MMn}/(\text{L}\cdot\text{min})$]	MN FLUX [$\mu\text{MMn}/(\text{m}^2\cdot\text{hr})$]	NUMBER OF CORES	MN FLUX MEAN	MN STANDARD DEVIATION
HGK	1	-0.016216	-132	3	-115	20.9873362
	2	-0.014384	-112			
	3	-0.011351	-102			
GNCV	1	-0.0065504	-57	3	-62	11.1184415
	2	-0.0088666	-75			
	3	-0.0063769	-55			
MDPT	1	0.0044738	38	3	47	25.1826298
	2	0.0095557	75			
	3	0.0031802	27			
R 64	1	-0.010888	-87	3	-120	28.2174788
	2	-0.014430	-135			
	3	-0.017562	-136			

OCTOBER 1994 FLUX continued

STATION	CORE NO	BLANK DO [mg/(L.min)]	BLANK NH4 [μMN/(L.min)]	BLANK pH [-log H/(L.min)]	BLANK NO2+NO3 [μMN/(L.min)]	BLANK DIP [μMP/(L.min)]	BLANK Si(OH)4 [μMSi/(L.min)]
HGNIK	1	0.00000	0.00000	0.00000	-0.03892	0.00000	0.11490
	2	0.00000	0.00000	0.00000	-0.03892	0.00000	0.11490
	3	0.00000	0.00000	0.00000	-0.03892	0.00000	0.11490
GNCV	1	-0.00081	0.00000	0.00000	0.00000	0.00000	0.00000
	2	-0.00081	0.00000	0.00000	0.00000	0.00000	0.00000
	3	-0.00081	0.00000	0.00000	0.00000	0.00000	0.00000
MDPT	1	-0.00021	0.00000	0.00000	0.00000	0.00000	0.00000
	2	-0.00021	0.00000	0.00000	0.00000	0.00000	0.00000
	3	-0.00021	0.00000	0.00000	0.00000	0.00000	0.00000
R 64	1	0.00026	0.00000	0.00000	0.00000	0.00000	0.01983
	2	0.00026	0.00000	0.00000	0.00000	0.00000	0.01983
	3	0.00026	0.00000	0.00000	0.00000	0.00000	0.01983

OCTOBER 1994 FLUX continued

STATION	CORE NO	BLANK	BLANK	BLANK	BLANK	BLANK	BLANK
		TCO2	DOC	DON	DOP	Fe	Mn
		[μMCO_2 /(L.min)]	[mg/(L.min)]	[μMN /(L.min)]	[μMP /(L.min)]	[μMFe /(L.min)]	[μMMn /(L.min)]
HGK	1	0.15411	-0.00037	0.00000	0.00000	-0.00477	0.00000
	2	0.15411	-0.00037	0.00000	0.00000	-0.00477	0.00000
	3	0.15411	-0.00037	0.00000	0.00000	-0.00477	0.00000
GNCV	1	0.00000	0.00000	0.00000	0.00000	-0.00303	0.00000
	2	0.00000	0.00000	0.00000	0.00000	-0.00303	0.00000
	3	0.00000	0.00000	0.00000	0.00000	-0.00303	0.00000
MDPT	1	0.16615	0.00000	0.00000	0.00000	-0.00286	0.00000
	2	0.16615	0.00000	0.00000	0.00000	-0.00286	0.00000
	3	0.16615	0.00000	0.00000	0.00000	-0.00286	0.00000
R 64	1	0.00000	0.00000	0.00000	-0.00019	-0.00159	0.00000
	2	0.00000	0.00000	0.00000	-0.00019	-0.00159	0.00000
	3	0.00000	0.00000	0.00000	-0.00019	-0.00159	0.00000

Numerical Water Quality and Contaminant Modeling (EL-22)
 Tidal Fresh Potomac River and Maryland Mainstem
 Total Carbon Dioxide Corrections at R 64

CORE	DATE	TCO2 FLUX [$\mu\text{MCO}_2/(\text{m}^2.\text{hr})$]	CaCO3 [$\mu\text{M}\text{Ca}/(\text{m}^2.\text{hr})$]	BIOTIC CO2 [$\mu\text{MCO}_2/(\text{m}^2.\text{hr})$]	FLUX MEAN [$\mu\text{MCO}_2/(\text{m}^2.\text{hr})$]
1	21MAY95	8924	-183	9107	
2	21MAY95	NI	104		9708
3	21MAY95	10309	NS	10309	
1	14JUL95	1735	NS	2767	
2	14JUL95	2585	NS	2096	1953
3	14JUL95	1538	NS	2203	
1	11AUG95	1894	-215	2109	
2	11AUG95	1651	NS	1651	1630
3	11AUG95	1634	503	1131	
1	17OCT95	3416	654	2762	
2	17OCT95	4299	783	3516	3067
3	17OCT95	3273	350	2923	

Numerical Water Quality and Contaminant Modeling (EL-22)
 Tidal Fresh Potomac River and Maryland Mainstem
 Sulfate Flux : Sulfate depletion from sediment pore water

STATION	DATE	SO4 RATE OF CHANGE (mg/L*day)	AVERAGE POROSITY %(wgt/wgt)	SEDIMENT VOLUME (L)	PROPERTY CONSTANT (cm ² /m ²)	SO4 FLUX (mg/m ² *day)	SO4 DEPLETION FLUX (mM SO4 m ⁻² *day)
HGNK	MAY	NI				NI	NI
GNCV	MAY	NI				NI	NI
MDPT	MAY	NI				NI	NI
R 64	MAY	NI				NI	NI
HGNK	JULY	0	0.87	0.05	1972	0.00	0.0
GNCV	JULY	NI				NI	NI
MDPT	JULY	-21.408	0.90	0.05	1972	-1899.75	19.8
R 64	JULY	-24.742	0.88	0.05	1972	-2146.81	22.4
HGNK	AUGUST	0	0.87	0.05	1972	0.00	0.0
GNCV	AUGUST	NI				NI	NI
MDPT	AUGUST	-16.389	0.89	0.05	1972	-1438.20	15.0
R 64	AUGUST	-16.348	0.92	0.05	1972	-1482.96	15.4
HGNK	OCTOBER	NI				NI	NI
GNCV	OCTOBER	NI				NI	NI
MDPT	OCTOBER	NI				NI	NI
R 64	OCTOBER	-16.438	0.87	0.05	1972	-1410.08	14.7

Numerical Water Quality and Contaminant Modeling (EL-22)
 Tidal Fresh Potomac River and Maryland Mainstem
 Methane Flux: In-situ method

STATION	DATE	TRAP SET-TIME (hr)	CH4 (mL)	%CH4	MASS (μ M)	CH4 FLUX [μ M/(m ² .hr)]
HGK	MAY	20	9	23.2	93.2	54.2
	JULY	27.0	SS			
	AUG	25	4	4.6	8.2	3.8
	OCT		0			
GNCV	MAY	19.5	15	26.5	177.5	105.8
	JULY	26.9	44	20.1	394.8	170.5
	AUG	24.8	128	25.1	1434.3	671.7
	OCT	27.1	65	21.1	612.3	262.5
MDPT	MAY		0			
	JULY		0			
	AUG	25.9	8	57.7	206.1	92.5
	OCT		0			

REPORT DOCUMENTATION PAGE

Form Approved
OMB No. 0704-0188

Public reporting burden for this collection of information is estimated to average 1 hour per response, including the time for reviewing instructions, searching existing data sources, gathering and maintaining the data needed, and completing and reviewing the collection of information. Send comments regarding this burden estimate or any other aspect of this collection of information, including suggestions for reducing this burden, to Washington Headquarters Services, Directorate for Information Operations and Reports, 1215 Jefferson Davis Highway, Suite 1204, Arlington, VA 22202-4302, and to the Office of Management and Budget, Paperwork Reduction Project (0704-0188), Washington, DC 20503.

1. AGENCY USE ONLY (Leave blank)	2. REPORT DATE July 1996	3. REPORT TYPE AND DATES COVERED Final report
---	------------------------------------	---

4. TITLE AND SUBTITLE Sediment-Water Fluxes and Sediment Analyses in Chesapeake Bay: Tidal Fresh Potomac River and Maryland Main Stem	5. FUNDING NUMBERS
--	---------------------------

6. AUTHOR(S) Walter R. Boynton, Peter Sampou, Janet M. Barnes, Barbara J. Weaver, L. L. Magdeburger	
--	--

7. PERFORMING ORGANIZATION NAME(S) AND ADDRESS(ES) Chesapeake Biological Laboratory Box 38, Solomons, MD 20688-0038; Horn Point Environmental Laboratory Cambridge, MD 21613-0775	8. PERFORMING ORGANIZATION REPORT NUMBER
--	---

9. SPONSORING / MONITORING AGENCY NAME(S) AND ADDRESS(ES) U.S. Army Corps of Engineers Washington, DC 20314-1000; U.S. Army Engineer Waterways Experiment Station 3909 Halls Ferry Road, Vicksburg, MS 39180-6199	10. SPONSORING / MONITORING AGENCY REPORT NUMBER Contract Report W-96-1
--	--

11. SUPPLEMENTARY NOTES Available from National Technical Information Service, 5285 Port Royal Road, Springfield, VA 22161.

12a. DISTRIBUTION / AVAILABILITY STATEMENT Approved for public release; distribution is unlimited.	12b. DISTRIBUTION CODE
--	-------------------------------

13. ABSTRACT (Maximum 200 words) The report describes sediment-water flux measurements and associated observations in the water column and benthic sediments. Observations were conducted at four stations in the tidal Potomac River and adjoining Chesapeake Bay from May through October 1994. Measures were collected to provide data for development and improvement of a diagenetic model of sediment processes in freshwater and salt-freshwater transition regions. Sediment-water flux measurements included ammonium, nitrate + nitrite, phosphate, silicate, dissolved organic nitrogen, dissolved organic phosphorus, dissolved organic carbon, dissolved oxygen, total CO ₂ , total iron, total manganese, and methane. Constituents measured in the water column included ammonium, nitrate + nitrite, phosphate, silicate, dissolved organic nitrogen, dissolved organic phosphorus, dissolved organic carbon, dissolved oxygen, total CO ₂ , total iron, total manganese, sulfate, pH, and temperature. Constituents measured in the sediments included ammonium, nitrate + nitrite, phosphate, silicate, dissolved organic nitrogen, dissolved organic phosphorus, dissolved organic carbon, alkalinity, total CO ₂ , iron, manganese, chloride, sulfate, sulfide, and pH.

14. SUBJECT TERMS Chesapeake Bay Dissolved oxygen Iron Manganese Mathematical models Nitrogen Nutrients Phosphorus Potomac River	15. NUMBER OF PAGES 145
16. PRICE CODE	

17. SECURITY CLASSIFICATION OF REPORT UNCLASSIFIED	18. SECURITY CLASSIFICATION OF THIS PAGE UNCLASSIFIED	19. SECURITY CLASSIFICATION OF ABSTRACT	20. LIMITATION OF ABSTRACT
--	---	--	-----------------------------------