

TA7
W34
no. CPAR-
GL-92-2
c.2



**US Army Corps
of Engineers**

Waterways Experiment
Station

US-CE-C PROPERTY OF THE
UNITED STATES GOVERNMENT

Final Report
CPAR-GL-92-2
December 1992

CONSTRUCTION PRODUCTIVITY ADVANCEMENT RESEARCH (CPAR) PROGRAM

SUMMARY OF RESEARCH ON ASPHALT RUBBER BINDERS AND MIXES

Compiled by

Gary L. Anderton

Approved For Public Release; Distribution Is Unlimited



RESEARCH LIBRARY
US ARMY ENGINEER WATERWAYS
EXPERIMENT STATION
VICKSBURG, MISSISSIPPI

**A Corps/Industry Partnership to Advance
Construction Productivity and Reduce Costs**

27825-432

1 A 7
W34
no. CPAR. GL-92-2

REPORT DOCUMENTATION PAGE

Form Approved *C.2*
OMB No. 0704-0188

Public reporting burden for this collection of information is estimated to average 1 hour per response, including the time for reviewing instructions, searching existing data sources, gathering and maintaining the data needed, and completing and reviewing the collection of information. Send comments regarding this burden estimate or any other aspect of this collection of information, including suggestions for reducing this burden, to Washington Headquarters Services, Directorate for Information Operations and Reports, 1215 Jefferson Davis Highway, Suite 1204, Arlington, VA 22202-4302, and to the Office of Management and Budget, Paperwork Reduction Project (0704-0188), Washington, DC 20503.

1. AGENCY USE ONLY (Leave blank)	2. REPORT DATE December 1992	3. REPORT TYPE AND DATES COVERED Final report
----------------------------------	---------------------------------	--

4. TITLE AND SUBTITLE Summary of Research on Asphalt Rubber Binders and Mixes	5. FUNDING NUMBERS CPAR Research Program Work Unit No. 32615
--	---

6. AUTHOR(S)
Gary L. Anderton, Gary L. Cooper, Jon A. Epps, Kent R. Hansen, Rudy A. Jimenez, Neil C. Krutz, and Mary Stroup-Gardiner

7. PERFORMING ORGANIZATION NAME(S) AND ADDRESS(ES) USAE Waterways Experiment Station Geotechnical Laboratory 3909 Halls Ferry Road Vicksburg, MS 39180-6199	8. PERFORMING ORGANIZATION REPORT NUMBER Technical Report CPAR-GL-92-2
---	--

9. SPONSORING / MONITORING AGENCY NAME(S) AND ADDRESS(ES)
US Army Corps of Engineers
20 Massachusetts Ave., NW
Washington, DC 20314-1000

10. SPONSORING / MONITORING AGENCY REPORT NUMBER

11. SUPPLEMENTARY NOTES
Available from National Technical Information Service, 5285 Port Royal Road, Springfield, VA 22161

12a. DISTRIBUTION / AVAILABILITY STATEMENT
Approved for public release; distribution is unlimited

12b. DISTRIBUTION CODE

13. ABSTRACT (Maximum 200 words)
This report summarizes the results obtained from a 2-year research study on asphalt rubber. The research study was part of a joint project between the US Army Corps of Engineers and the Asphalt Rubber Producers Group (ARPG) under the Corps' Construction Productivity Advancement Research (CPAR) program. Individual studies of differing research areas were conducted by several agencies, including: the US Army Engineer Waterways Experiment Station's (WES) Pavement Systems Division, the University of Nevada-Reno (UNR), the University of Arizona (UA), International Surfacing, Inc. (ISI), and Crafcro, Inc. Each individual study is presented in a separate chapter of this summary report. Details of the research conducted by WES for this project have previously been published in the Interim Report CPAR-GL-92-1 entitled "Evaluation of Asphalt Rubber Binders in Porous Friction Courses."

14. SUBJECT TERMS Asphalt concrete Asphalt modifiers Asphalt rubber	Pavement construction Pavement design Recycling
--	---

15. NUMBER OF PAGES
125

16. PRICE CODE

17. SECURITY CLASSIFICATION OF REPORT
Unclassified

18. SECURITY CLASSIFICATION OF THIS PAGE
Unclassified

19. SECURITY CLASSIFICATION OF ABSTRACT
Unclassified

20. LIMITATION OF ABSTRACT

Chapter 1

Project Overview on Asphalt Rubber Research Study

By

Gary L. Anderton, Gary L. Cooper, Kent R. Hansen

PREFACE

This study was directed by the Geotechnical Laboratory (GL), US Army Engineer Waterways Experiment Station (WES), Vicksburg, MS, for the US Army Corps of Engineers (USACE) under the Construction Productivity Advancement Research (CPAR) Program. The work was conducted from October 1989 to February 1992 under the project entitled "Asphalt Rubber." The USACE Technical Monitor was Mr. Andy Constantaras.

The laboratory evaluations summarized in this report were part of a joint research program which was equally funded by the USACE CPAR program and the Asphalt Rubber Producers Group (ARPG). USACE funds were used to support the research conducted by WES, and ARPG funds were used to support the research conducted by various academic and industry agencies including the University of Nevada-Reno, the University of Arizona, Crafcoc, Inc., and International Surfacing, Inc.

The study was conducted under the general supervision of Dr. W. F. Marcuson III, Director, GL; Mr. H. H. Ulery, Jr., former Chief, Pavement Systems Division (PSD); and Mr. T. W. Vollar, Chief, Materials Research and Construction Technology Branch, PSD. This report was prepared under the direct supervision of Dr. G. M. Hammitt II, Chief, PSD. The project's Principal Investigator was Mr. G. L. Anderton. Mr. Anderton directed the organization of this report with assistance from Mr. Al France of ARPG, who collected the individual chapters from the respective authors. Mr. G. L. Cooper of ARPG, who acted as the CPAR industry partner's authorized representative, reviewed this report before publication.

Each chapter of this summary report presents the findings of individual research studies. The authors of these chapters were responsible for the respective study areas. The chapter authors include Messrs. G. L. Anderton, G. L. Cooper, J. A. Epps, K. R. Hansen, R. A. Jimenez, N. C. Krutz, and Ms. M. Stroup-Gardiner. Those chapters that were not prepared by WES representatives were published as received.

At the time of publication of this report, Director of WES was Dr. Robert W. Whalin. Commander was COL Leonard G. Hassell, EN.

Table of Contents

Chapter 1

INTRODUCTION	3
Construction Productivity Advancement Research	3
Research Study	3
MATERIALS	4
Binders	4
Aggregate	4
BINDER TESTING	5
Physical Properties And Aging Characteristics Of Asphalt-Rubber Binders	5
Tensile Creep Comparison Of Asphalt Cement And Asphalt-Rubber Binders	8
MIX DESIGN	9
Comparison Of Mix Design Methods For Asphalt-Rubber Concrete Mixtures	9
Asphalt-Rubber Open-Graded Friction Courses	10
DENSE GRADED MIX CHARACTERISTICS	12
Optimum Binder Contents	12
Permanent Deformation Characteristics	13
Low Temperature Cracking Characteristics	14
Fatigue Of Asphalt And Asphalt-Rubber Concrete	16
CONCLUSIONS	17

List of Tables

Table 1	Mix Binder Contents	13
---------	---------------------	----

List of Figures

Figure 1	Absolute and Brookfield Viscosities	5
Figure 2	Needle Penetration	6
Figure 3	Softening Point	6
Figure 4	Resilience	6
Figure 5	Thin Film Oven Aging Comparison	7
Figure 6	Weatherometer Aging Comparison	7
Figure 7	Stiffness Modulus vs Temperature	8
Figure 8	Comparison of Mix Design Methods	9
Figure 9	Resilient Modulus vs Temperature	10
Figure 10	Open Graded Mix Comparison, Drain Off Test	11
Figure 11	Open Graded Mix Comparison, Permeability	11
Figure 12	Open Graded Mix Comparison, Stripping Potential	12
Figure 13	Creep Modulus from Static Testing	13
Figure 14	Repeated Load Compressive Creep, 77°F	14
Figure 15	Repeated Load Compressive Creep, 77°F	14
Figure 16	Indirect Tensile Strength Comparison	15
Figure 17	Thermally Induced Stress vs Temperature	15
Figure 18	Deflectometer Fatigue Comparison, AC-5 and AC-5R	16

INTRODUCTION

Construction Productivity Advancement Research

In November of 1989, the U.S. Army Corps of Engineers Waterways Experiment Station and the Asphalt Rubber Producers Group signed a Cooperative Research and Development Agreement which marked the beginning of a two-year joint research study on asphalt-rubber. This agreement was the first enacted on within the Corps' new Construction Productivity Advancement Research (CPAR) program. The potential benefits of this developing technology for both the Federal Government and the private sector made the asphalt-rubber research study perfectly suited for the CPAR program.

CPAR is a cost-shared research and development partnership between the Corps and the U.S. construction industry, academic institutions, public and private foundations, non-profit organizations, state and local governments and other entities who are interested in construction productivity and competitiveness. CPAR is designed to promote and assist in the advancement of ideas and technologies that will have a direct positive impact on construction productivity and project cost and on Corps mission accomplishment. The CPAR program has received strong support from the U.S. construction industry and numerous projects have been funded since the program was initiated in 1989.

Research Study

This report digests the results obtained from the two-year asphalt-rubber research study. Individual studies of differing research areas were conducted by several agencies including: the U.S. Army Engineer Waterways Experiment Station's (WES) Pavement Systems Division, the University of Nevada-Reno (UNR), the University of Arizona (UA), International Surfacing, Inc. (ISI) and Crafcoc, Inc. Detailed reports of these individual studies are documented in the Technical Reports listed below:

- Volume 1 - Summary of Research on Asphalt-Rubber Binders and Mixes
- Volume 2 - Physical Properties and Aging Characteristics of Asphalt-Rubber Binders
- Volume 3 - Tensile Creep Comparison of Asphalt Cement and Asphalt-Rubber Binders
- Volume 4 - Comparison of Mix Design Methods for Asphalt-Rubber Concrete Mixtures
- Volume 5 - Permanent Deformation Characteristics of Recycled Tire Rubber Modified and Unmodified Asphalt Concrete Mixtures
- Volume 6 - Low Temperature Cracking Characteristics of Ground Rubber and Unmodified Asphalt Concrete Mixtures

Volume 7 - Fatigue of Asphalt and Asphalt-Rubber Concretes

Volume 8 - Asphalt-Rubber Open-Graded Friction Courses

Copies of these Technical Reports may be obtained by contacting:

Asphalt Rubber Producers Group
312 Massachusetts Ave. NE
Washington D. C. 20002

Summaries of Volumes 2 through 8 are included in Chapters 2 through 8 of this report.

MATERIALS

Binders

Binders described in this report are abbreviated as follows:

AC-5	Witco AR 1000 (AC-5) Asphalt Cement.
AC-20	Witco AC-20 Asphalt Cement.
AC-40	Witco AC-40 Asphalt Cement.
AC-5RE	79% Witco AR 1000(AC-5) Asphalt Cement, 5% San Joaquin 1200S Extender Oil and 16% Baker IGR 24 Rubber.
AC-5R	83% Witco AR 1000 (AC-5) Asphalt Cement and 17% Baker IGR-24 Rubber.
AC-20R	84% Witco AC-20 Asphalt Cement and 16% Baker IGR-24 rubber.

Aggregate

The aggregate was obtained from Granite Rock Co., Watsonville, California. The gradation was chosen to meet ASTM D3315 1/2-inch dense mixture, Nevada Type 2 and California 1/2-inch medium specifications.

BINDER TESTING

Physical Properties and Aging Characteristics of Asphalt-Rubber Binders

Asphalt cement and asphalt-rubber binders were evaluated in report Volume 2, "Physical Properties and Aging Characteristics of Asphalt-Rubber Binders", Gary Anderton, WES, using the following tests:

- Absolute Viscosity (140°F)
- Kinematic Viscosity (275°F) - asphalt cement only
- Brookfield & Haake Viscosities (194°F to 275°F)
- Penetration, Cone and Needle, (39°F & 77°F)
- Ductility, (39°F & 77°F)
- Softening Point
- Resiliency

Binders were also evaluated after aging using the Thin Film Oven Test (TFOT) and Weatherometer. The binders were tested using the following tests before and after aging:

- Absolute Viscosity (140°F)
- Penetration, Cone and Needle, (77°F)
- Softening Point
- Weight Loss

Figure 1 shows a typical temperature viscosity relationship for a asphalt-rubber and unmodified asphalt cements. This and other viscosity test results demonstrate the conclusion that the addition of 16 to 17 percent ground recycled tire rubber to an asphalt cement will increase the binder viscosity by 100 to 2000 percent, depending upon the test method and test temperature.

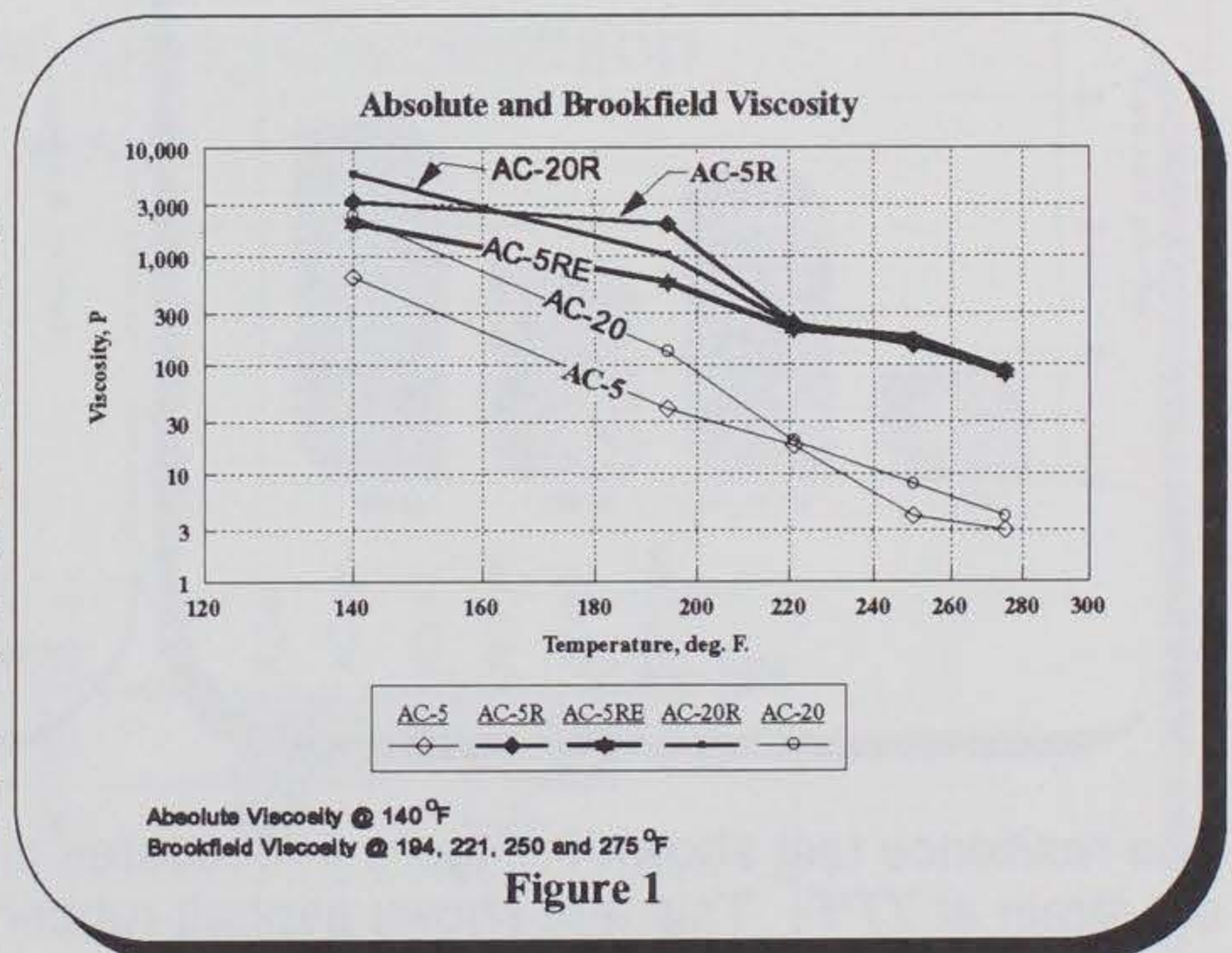

The viscosity tests also show that differing grades of asphalt-rubber binders produced with similar dosage levels of the same rubber have very similar viscosities between 200°F and 275°F. This indicates that above about 200°F, the viscosity of the binder is controlled by the rubber and below 200°F, the base asphalt cement has a significant influence on binder viscosity.

Needle penetration test results for four of the binders are shown in Figure 2. These data illustrate that the addition of recycled tire rubber can: (1) improve low-temperature binder properties as indicated by the 39.2°F pen; and (2) reduce overall temperature susceptibilities as indicated by the difference between the 39.2 and 77°F penetration tests.

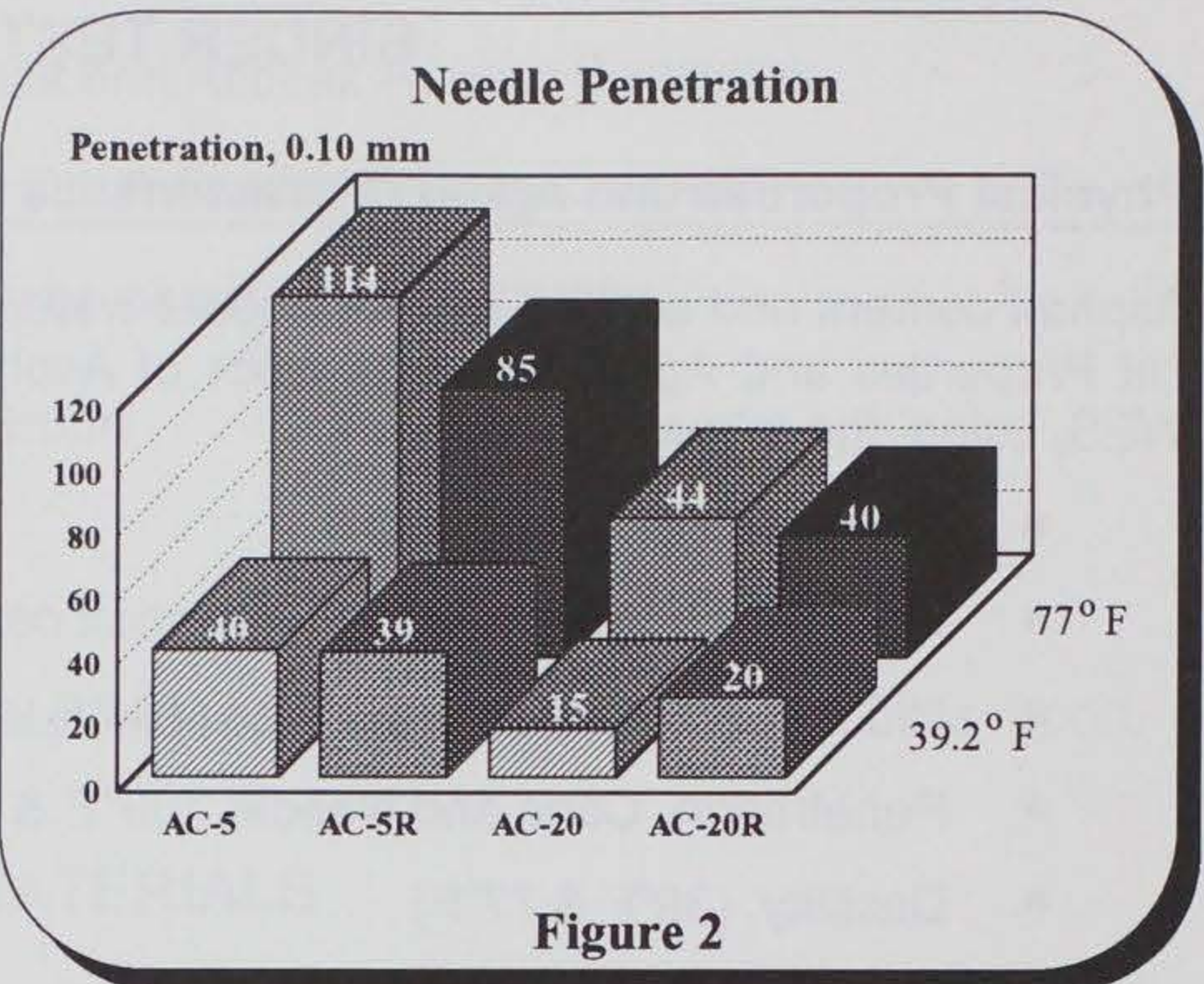

Figure 2

Softening points test results for four binders are shown in Figure 3. These tests show softening points are increased by approximately 20 to 30°F by the addition of 16 to 17 percent recycled tire rubber. It is important to note that the AC-5R has a higher softening point than the AC-20. This testing indicates that asphalt-rubber concrete pavements should be less susceptible to traffic-induced deformation distress at high pavement temperatures. This may also be true when comparing the AC-5R to the AC-20.

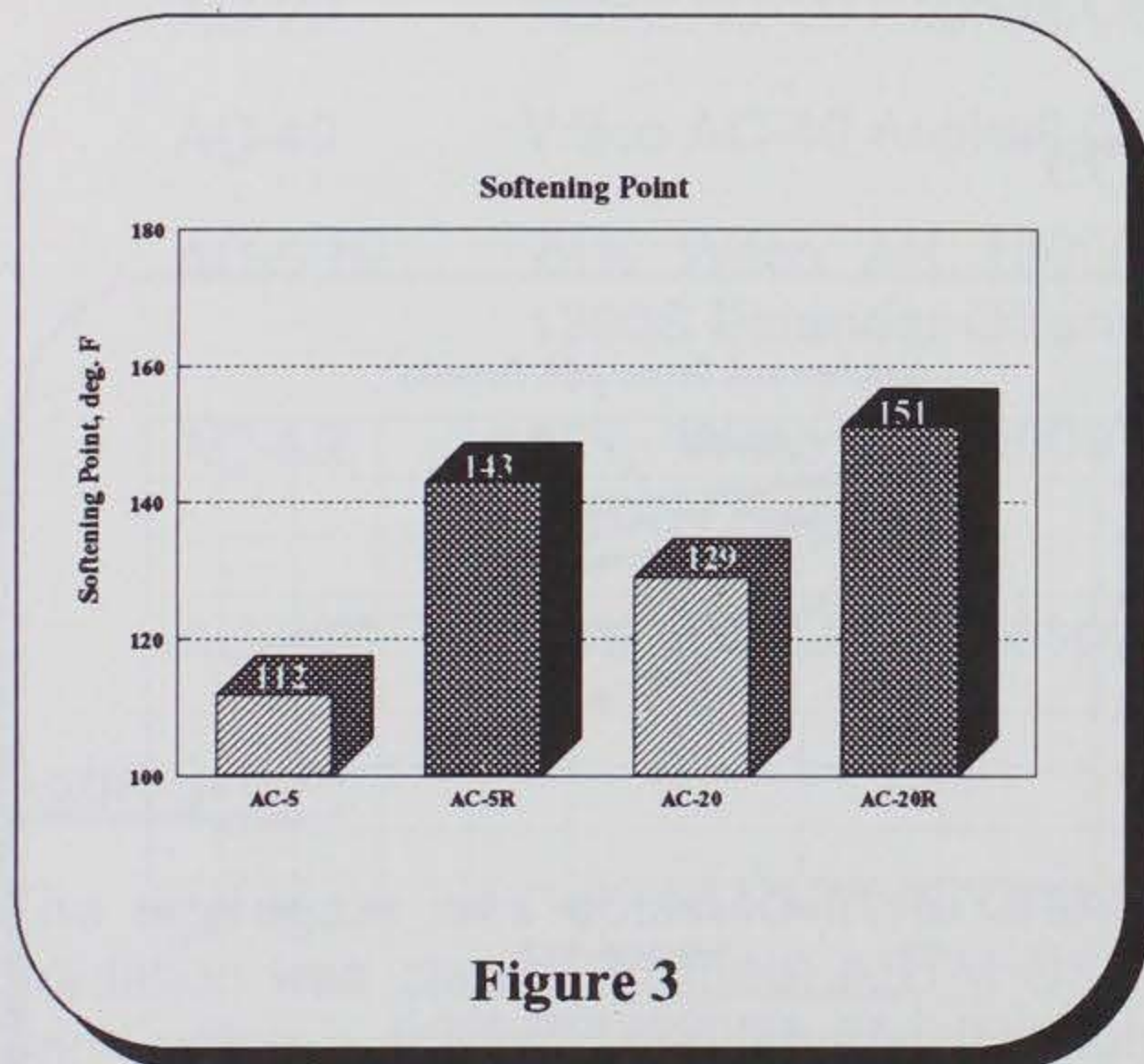

Figure 3

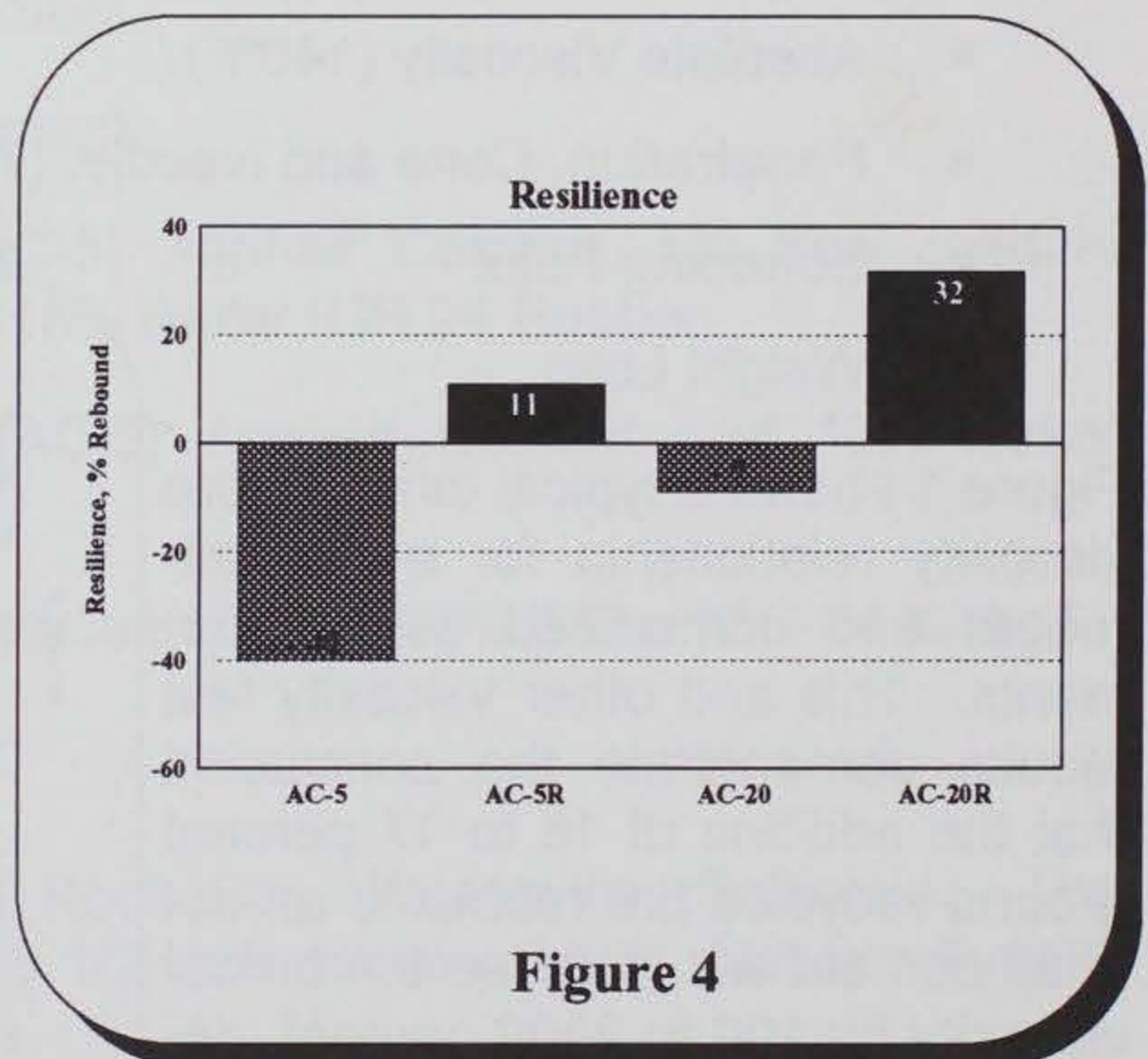

Figure 4

The resilience test shown in Figure 4 measures the ability of a binder to recover from a set strain at 77°F. This test shows asphalt-rubber binders have higher elastic recovery potentials than unmodified asphalt cement binders. This test also indicates that asphalt-rubber concrete mixes should show improved resistance to high temperature deformation when compared to unmodified mixes.

Viscosity and 77°F penetration test results on thin film oven test (TFOT) aged samples are shown in Figure 5. The viscosity tests illustrate that plant aging of asphalt-rubber binders, with the exception of the AC-5RE, is about 50 percent less than asphalt cement binders. The penetration tests show improved plant aging resistance for all asphalt-rubber binders.

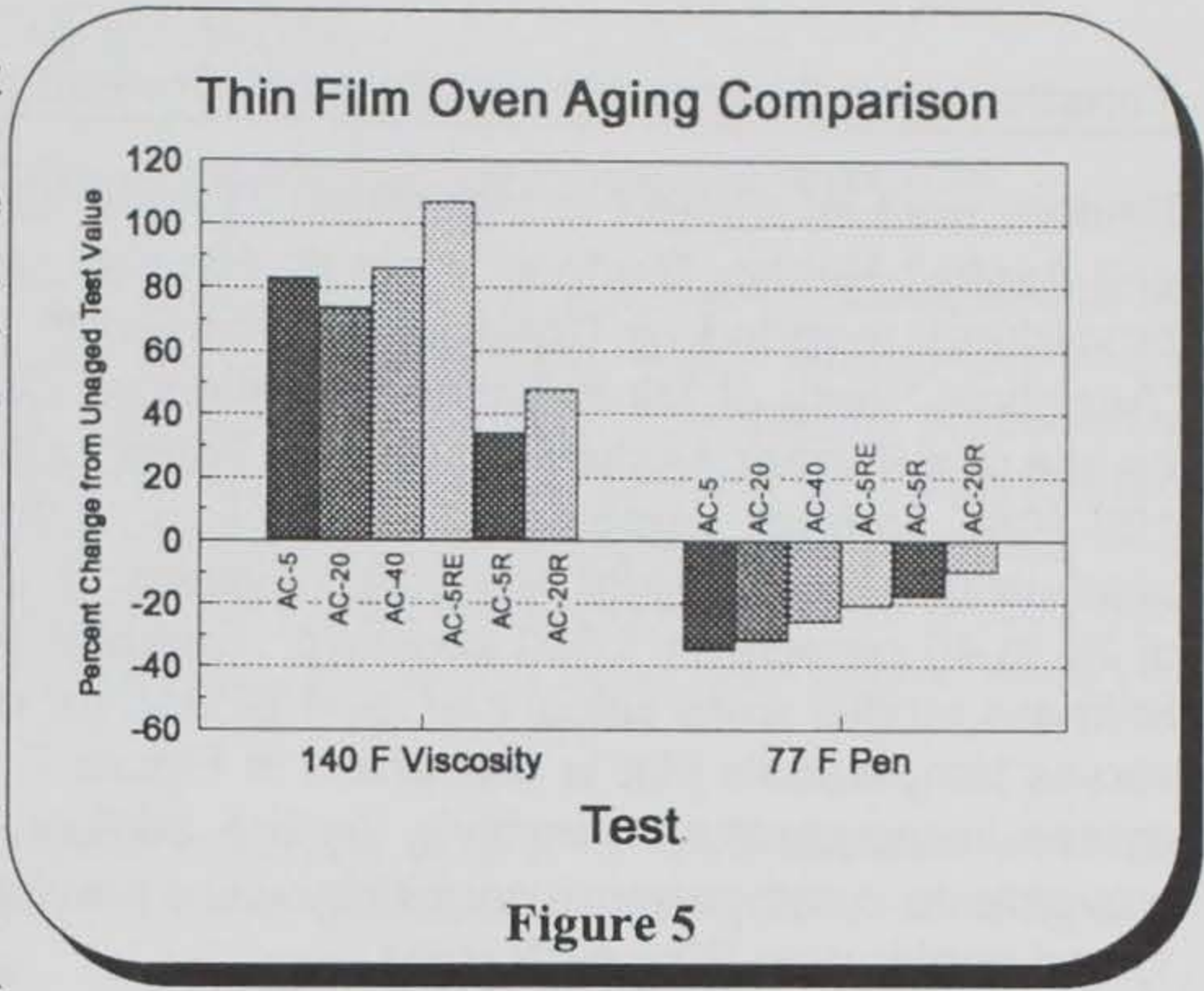

Figure 5

Asphalt-rubber binders had higher weight losses after thin film oven test aging when compared to the asphalt cement binders, but the amount of weight loss did not appear to significantly affect other aging properties.

Figure 6 presents the results of viscosity and penetration tests on samples aged in the weatherometer. This accelerated aging subjects the specimens to heat, ultra violet light and moisture to simulate environmental aging. Viscosity tests show all asphalt-rubbers, with the exception of the AC-5RE, to have reduced environmental aging. The penetration tests show improved aging resistance for all asphalt-rubber binders when compared to the base asphalt.

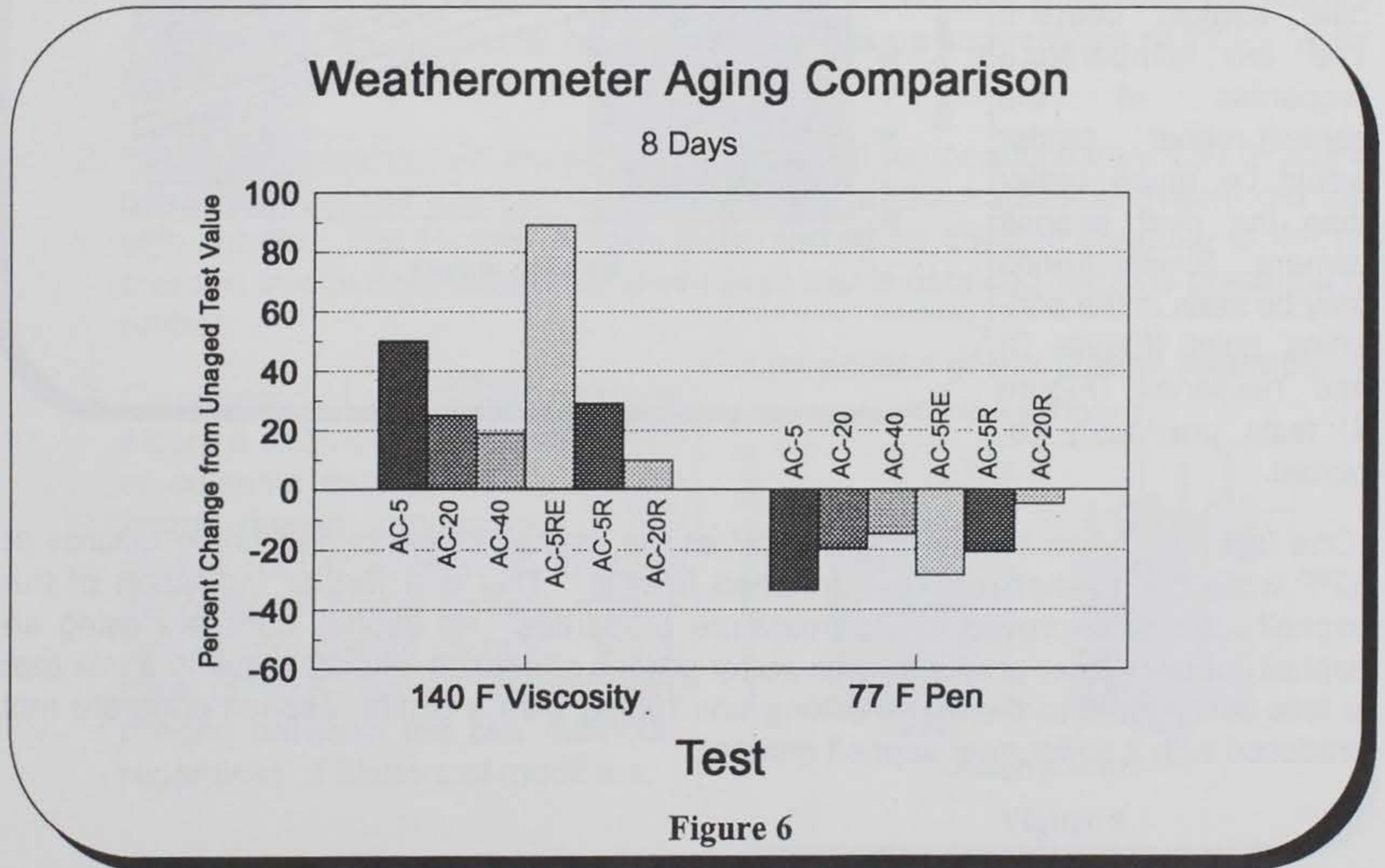

Figure 6

Tensile Creep Comparison of Asphalt Cement and Asphalt-Rubber Binders

Binders were evaluated in Volume 2, "Tensile Creep Comparison of Asphalt Cement and Asphalt-Rubber Binders", Kent R. Hansen and Anne Stonex, ISI, using creep test procedures reported by Coetzee and Monismith (Coetzee, N.F., and Monismith, C.L., "Analytical Study of Minimization of Reflective Cracking in Asphalt Concrete Overlays by use of a Rubber Asphalt Interlayer". Transportation Research Record 700, 1979, pp. 100-108). In brief, samples are tested in a modified ductility bath where a load is applied using a dead weight and pulley system. The load was selected to obtain a strain of 20 to 40 percent at 1,000 seconds. Samples were tested at 22, 39.2, 55 and 77°F. Stiffness moduli were calculated, and plotted for each test. A typical stiffness modulus verses temperature plot is presented in Figure 7. This testing shows a significant decrease in temperature sensitivity by the addition of recycled tire rubber. Similar improvements in temperature sensitivity were previously noted based on viscosity (Figure 1) and penetration (Figure 2) tests.

The tensile creep tests also show that similar high temperature stiffness may be achieved with an asphalt-rubber produced with an asphalt cement 2 to 3 grades softer than the neat asphalt cement. The low temperature properties of the asphalt-rubber binder would be much better than the neat asphalt cement. Similar trends may be seen in the softening point (Figure 3) and resilience (Figure 4) tests previously reported.

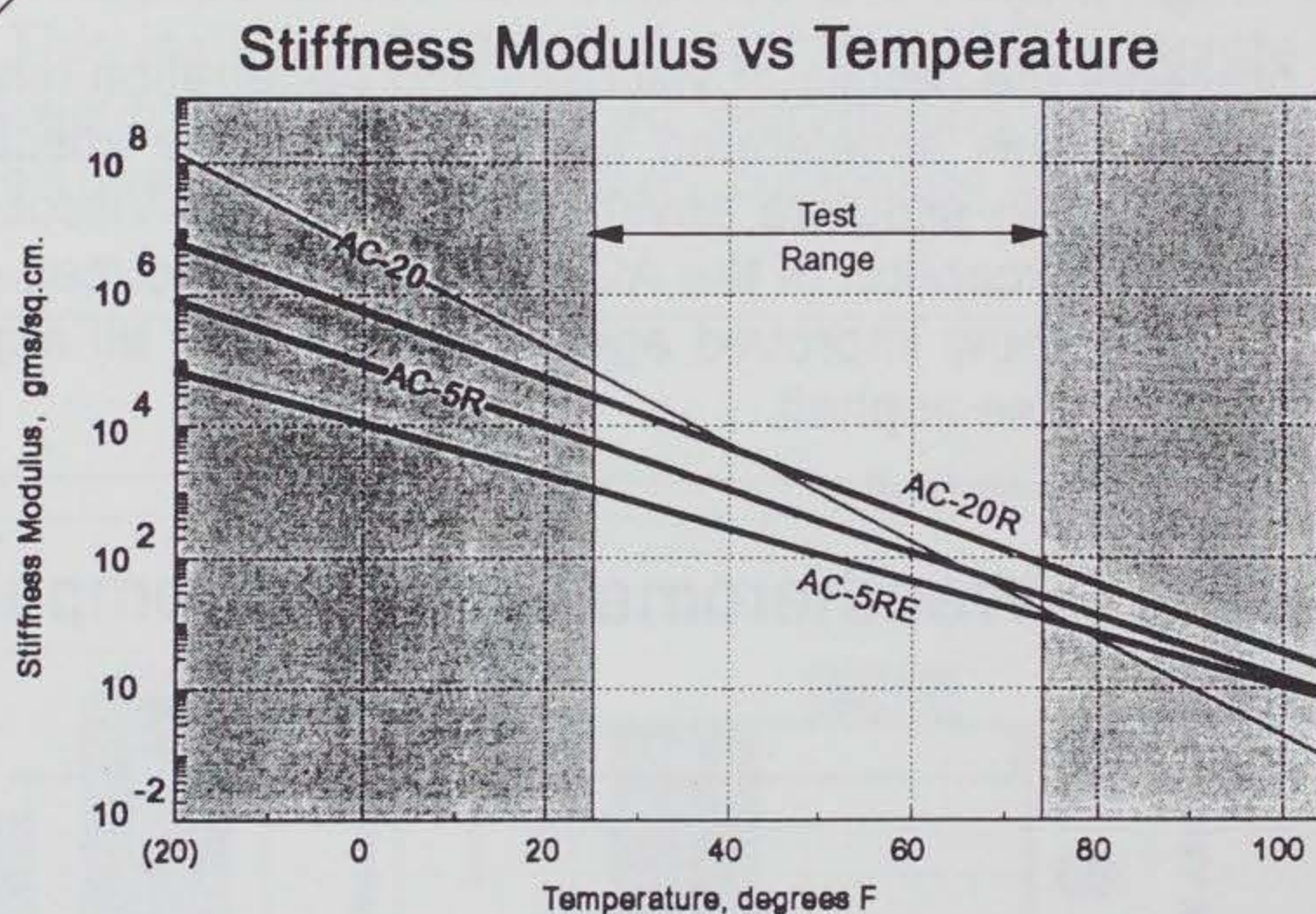

Figure 7

One fact not shown on the plots is that all the asphalt cements had brittle failures at 22°F while the asphalt-rubbers remained flexible. This is a further indication of the asphalt-rubbers' improved low temperature properties. An asphalt concrete using an asphalt-rubber binder produced with softer grades of asphalt should result in a mix that is less susceptible to thermal cracking and rutting than a similar asphalt concrete mix produced with a stiffer neat asphalt cement.

MIX DESIGN

Comparison of Mix Design Methods for Asphalt-Rubber Concrete Mixtures

Marshall and Hveem mix design methods were evaluated in Volume 3, "Comparison of Mix Design Methods for Asphalt-Rubber Concrete Mixtures", Mary Stroup-Gardiner, Neil Krutz and Jon Epps, Ph.D., UNR. Marshall and Hveem mix design procedures were used to determine optimum binder contents using the binders and aggregates previously referenced. The conventional asphalt concrete samples were prepared and tested according to ASTM D1559 (Marshall), 50 blows per side, and ASTM D1560 and 1561 (Hveem) procedures. Slight modifications, which are described below, were required for the asphalt-rubber mixes.

Asphalt-rubber Marshall specimens were compacted at 275°F. The samples were allowed to cool overnight before extruding to prevent the specimens from expanding due to the resilient properties of the rubber.

An attempt to compact the asphalt-rubber Hveem specimens at 230°F resulted in unacceptable test results. Based on these test results the decision was made to increase the compaction temperature to 300°F.

Some of the conclusions of this research are:

1. Marshall mix design: Asphalt-rubber mixtures can be expected to exhibit lower stability and unit weights, and higher VMA and flow than unmodified mixtures; four percent air voids can be obtained with asphalt-rubber mixtures. It is recommended that the flow limits be increased; previous suggestions of 22 to 24 for flow appear to be reasonable.
2. Hveem mix design: An increase in compaction temperature from 230 to 300°F produces mixtures that can meet the majority of the traditional Hveem mix design criteria. The Hveem stability limits should be lowered because of the increased lateral deformation per given load that is obtained with the presence of rubber.

3. Comparison of mix design methods:

Figure 8 shows recommended binder contents determined by the different design procedures. The asphalt-rubber appears to increase the optimum binder content, regardless of mix design method. Variations of +0.5 percent asphalt were noticed between the two methods, regardless of binders or modifiers.

Comparison of Mix Design Methods

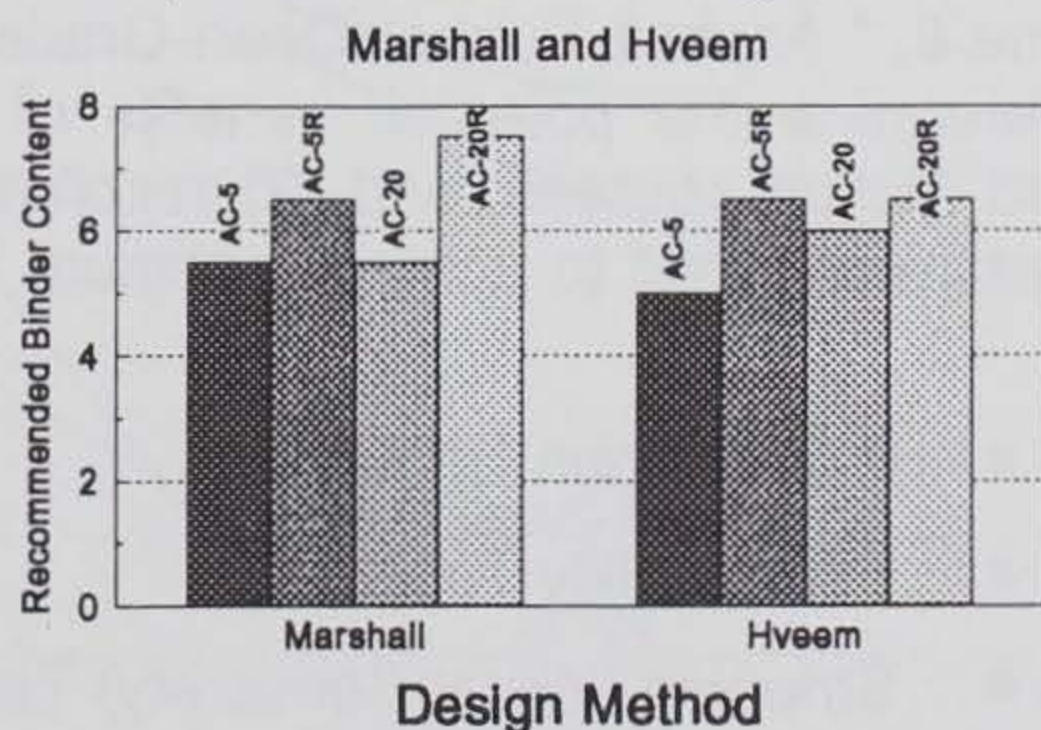

Figure 8

4. Fundamental material properties: Figure 9 presents resilient modulus vs. temperature for asphalt concrete mixtures produced using four of the binders. A significant reduction in material stiffness at cold temperatures is obtained when asphalt-rubber is added to the mixture. Material stiffness can possibly be increased at warmer temperatures by using asphalt-rubber. The addition of rubber tends to result in a slight reduction in tensile strengths.

Resilient Modulus vs. Temperature

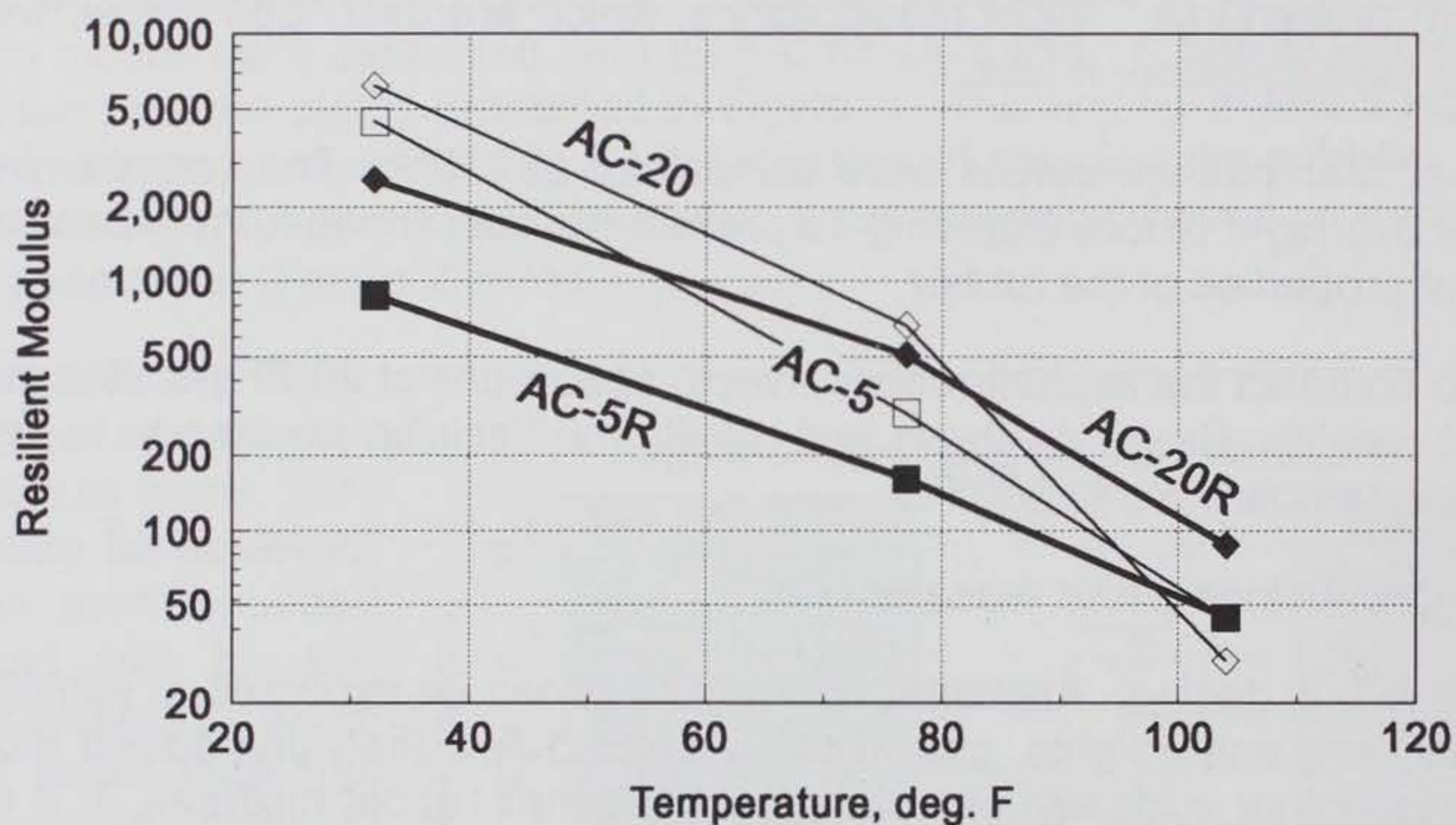

Figure 9

The reduced temperature sensitivity was previously noted in binder tests: viscosity (Figure 1); penetration (Figure 2); and tensile creep (Figure 7).

Asphalt-Rubber Open-Graded Friction Courses

The use of asphalt-rubber binders in open graded friction courses was evaluated in Volume 8, "Asphalt-Rubber Open-Graded Friction Courses," Gary Anderton, WES, to: (1) determine the potential benefits of asphalt-rubber binders when used in open graded friction courses; and (2) recommend asphalt cement grades and mix design procedure required to achieve optimum field performance. Mixes were evaluated using:

- Binder Drain Off Tests
- Permeability Tests
- Stripping (Water Sensitivity) Tests

The use of asphalt-rubber binder showed a significant improvement in binder drain off. A comparison of AC-20 and AC-5R is shown in Figure 10. This shows that when asphalt-rubber is used, the binder content can be increased and the mix temperature can also be increased. The reduced drain off, even at higher temperatures, is likely due to the higher viscosities of the asphalt-rubber binders at high temperatures as previously shown in Figure 1.

Laboratory permeability tests were conducted on open graded mixes produced with each test binder. The test specimens consisted of a 3/4-inch thick open-graded mix on a dense graded mix. The open-graded asphalt cement mixes were mixed at 275°F with binder contents of 6.6, 7.6, and 8.6 percent. The asphalt-rubber samples were mixed at 300°F at binder contents of 8.0, 9.0, and 10.0 percent. Figure 11 presents the results of the permeability tests for four of the mixes tested. This shows equal or better permeability for the asphalt-rubber mixes, even at higher binder contents.

The voids of the compacted open-graded mixes were also evaluated. Six-inch diameter, two-inch high specimens were compacted with 25 blows of a Marshall hand compactor on one side. The specimens were weighed in air and water to determine the void content and density. This data showed the asphalt-rubber mixes had higher voids than the asphalt mixes, which agrees

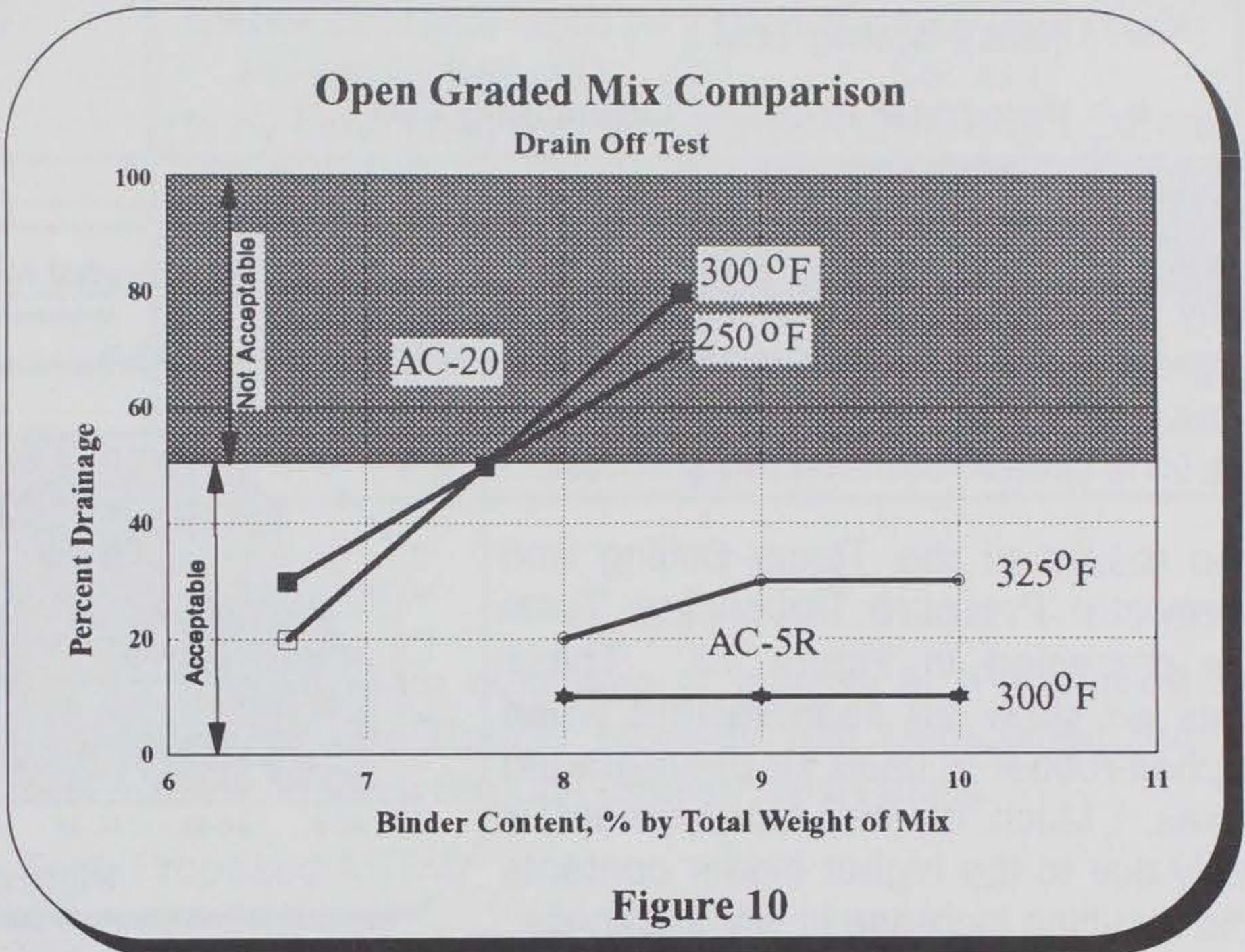

Figure 10

Figure 11 presents the results of the permeability tests for four of the mixes tested. This shows equal or better permeability for the asphalt-rubber mixes, even at higher binder contents.

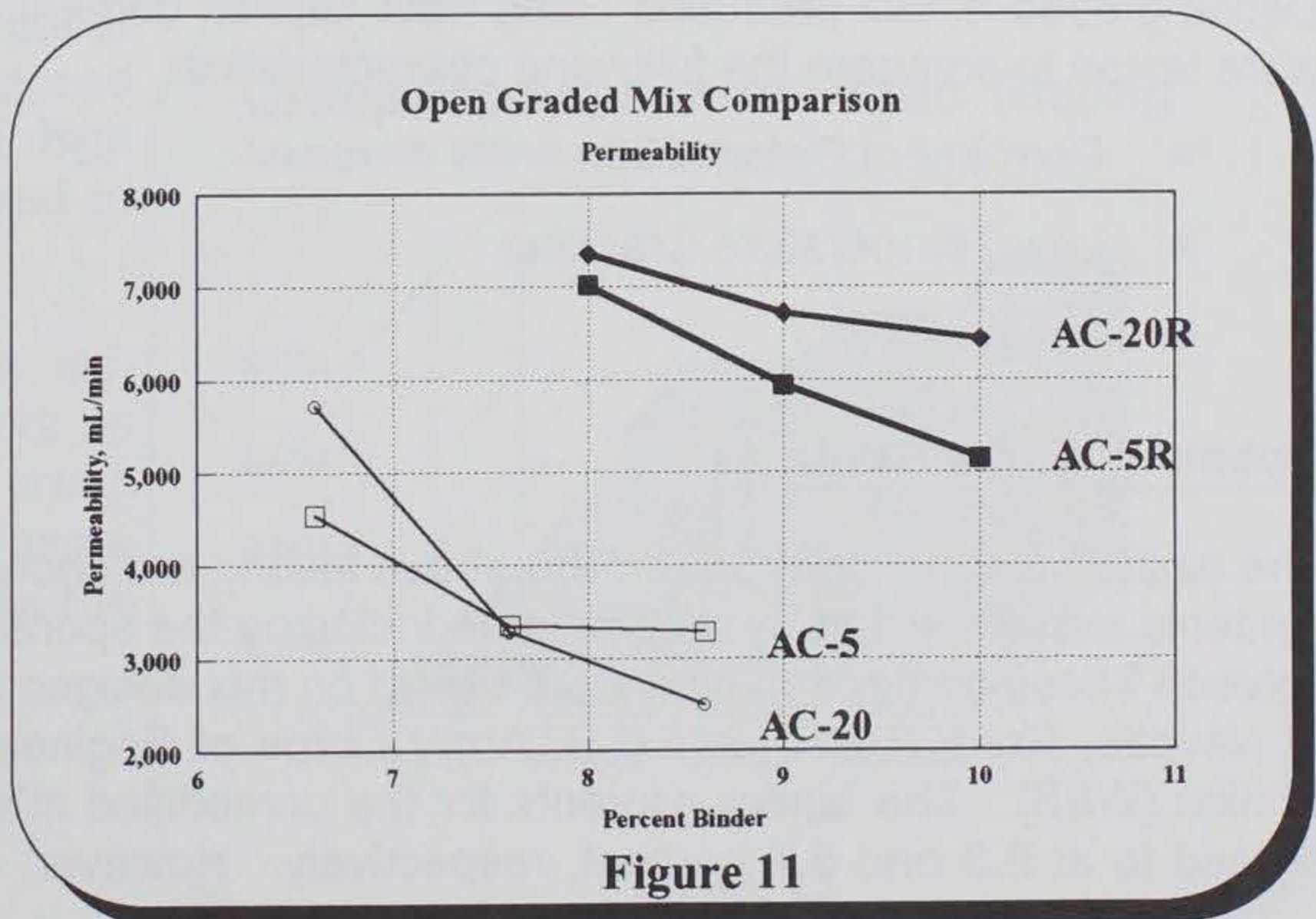

Figure 11

with the permeability test results. However, this data also shows increased density for the asphalt-rubber mixes. The combination of higher voids and higher density appears contradictory. Determining the unit weight of a high void mix by weighing the specimens in air and water may have introduced errors due to absorption of water in the mix.

The stripping potential of the mixes were evaluated using the following test procedures:

- ASTM D1664
- Texas Boiling Test
- Porewater Pressure Debonding Test

The ASTM procedure is considered the least severe of the tests used and typically identifies only those binders and aggregates with serious stripping problems. All of the binders tested passed the 95% binder retention requirement.

The results of the Texas Boiling and Porewater Pressure Debonding Tests are presented in Figure 12. These tests do show an improvement when asphalt-rubber is used for open-graded mixes. Much of this improvement is likely due to the higher binder contents and resulting increase in film thickness.

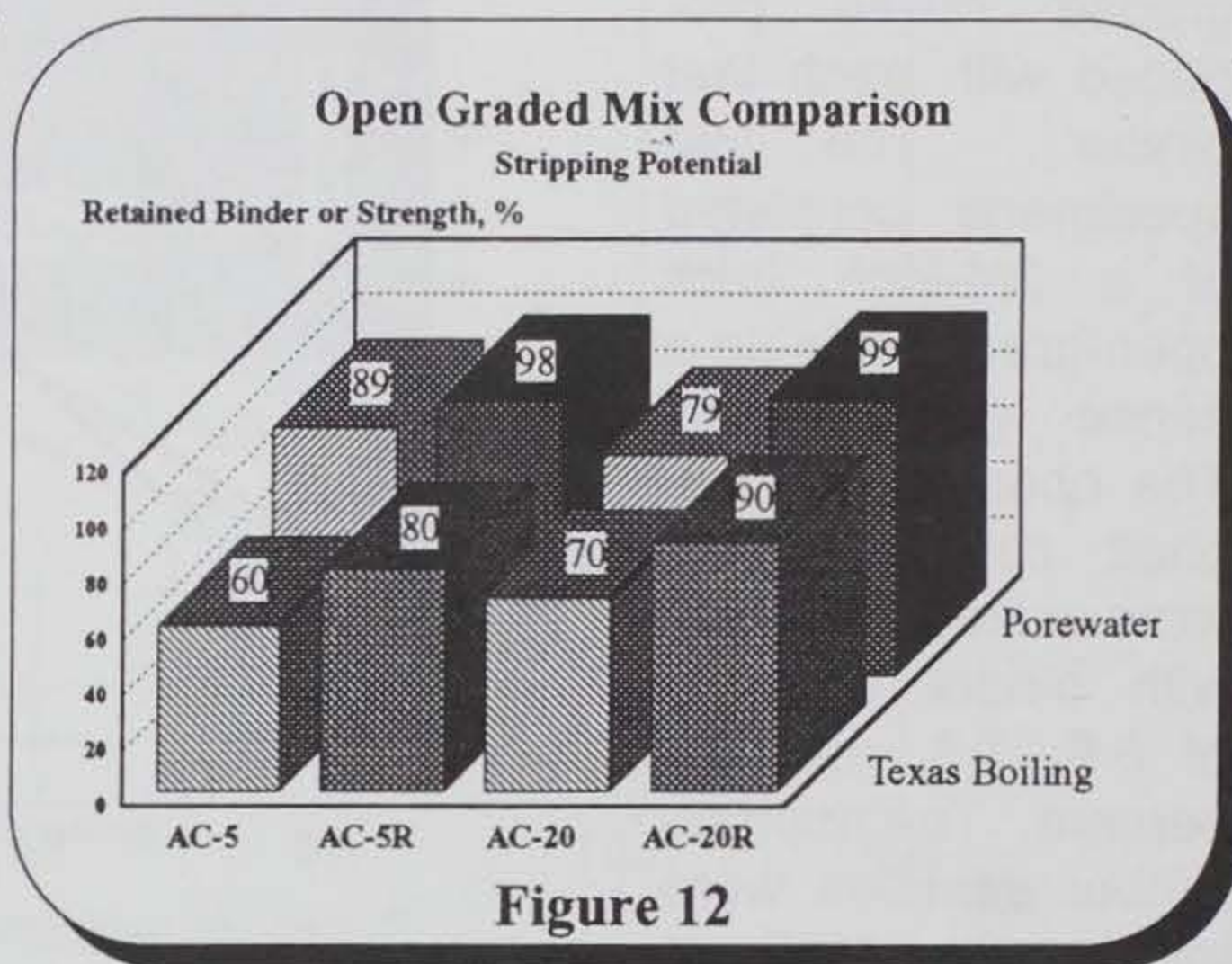

Figure 12

DENSE GRADED MIX CHARACTERISTICS

Dense graded mixes produced using neat asphalt cement and asphalt-rubber binders were tested to compare the following characteristics:

- Permanent Deformation
- Low Temperature Cracking
- Fatigue

Optimum Binder Contents

The binder contents selected for the above testing are shown in Table 1. These binder contents were selected by a committee including the sponsors and the researchers involved. These binder contents were based on mix designs performed by the University of Nevada, Reno (UNR) and U.S. Army Corps of Engineers, Waterways Experiment Station (WES). The binder contents for the unmodified mixes, AC-5 and AC-20, were agreed to at 5.3 and 5.7 percent, respectively. However, the mix designs from UNR

and WES for the modified binder did not agree. Therefore a compromise, agreeable to all parties, was made. These binder contents are higher than the recommend binder contents previously reported in this report. The researchers involved in evaluating the dense graded mix characteristics have reported that the binder contents appeared high. It is important that this be considered when evaluating these test results.

Table 1

Type of Binder	Binder Contents Used in Preparing Samples (% by Total Weight of Mix)	UNR Recommend Binder Content (% by Total Weight Of Mix)
AC-5	5.3	
AC-20	5.7	
AC-5RE	8.5	7.7
AC-5R	8.3	7.7
AC-20R	7.9	7.4

Permanent Deformation Characteristics

Permanent deformation characteristics were evaluated in Volume 5, "Permanent Deformation Characteristic of Recycled Tire Rubber Modified and Unmodified Asphalt Concrete Mixtures," Neil C. Krutz and Mary Stroup-Gardiner, UNR using:

- Static Creep Test (Proposed ASTM)
- Tri-axial, Confined, Repeated Load (SHRP Interim Test Procedure)

Tests were conducted at 77°F and 104°F using both procedures.

Figure 13 shows the results of static creep testing for four of the mixes tested. This testing shows that asphalt-rubber concrete mixtures have reduced permanent deformation at high temperatures when compared to unmodified mixtures.

It should be noted that the stiffness modulus of the binders as determined by the tensile creep test (Figure 7) shows the same relative ranking at 104°F as the static creep test.

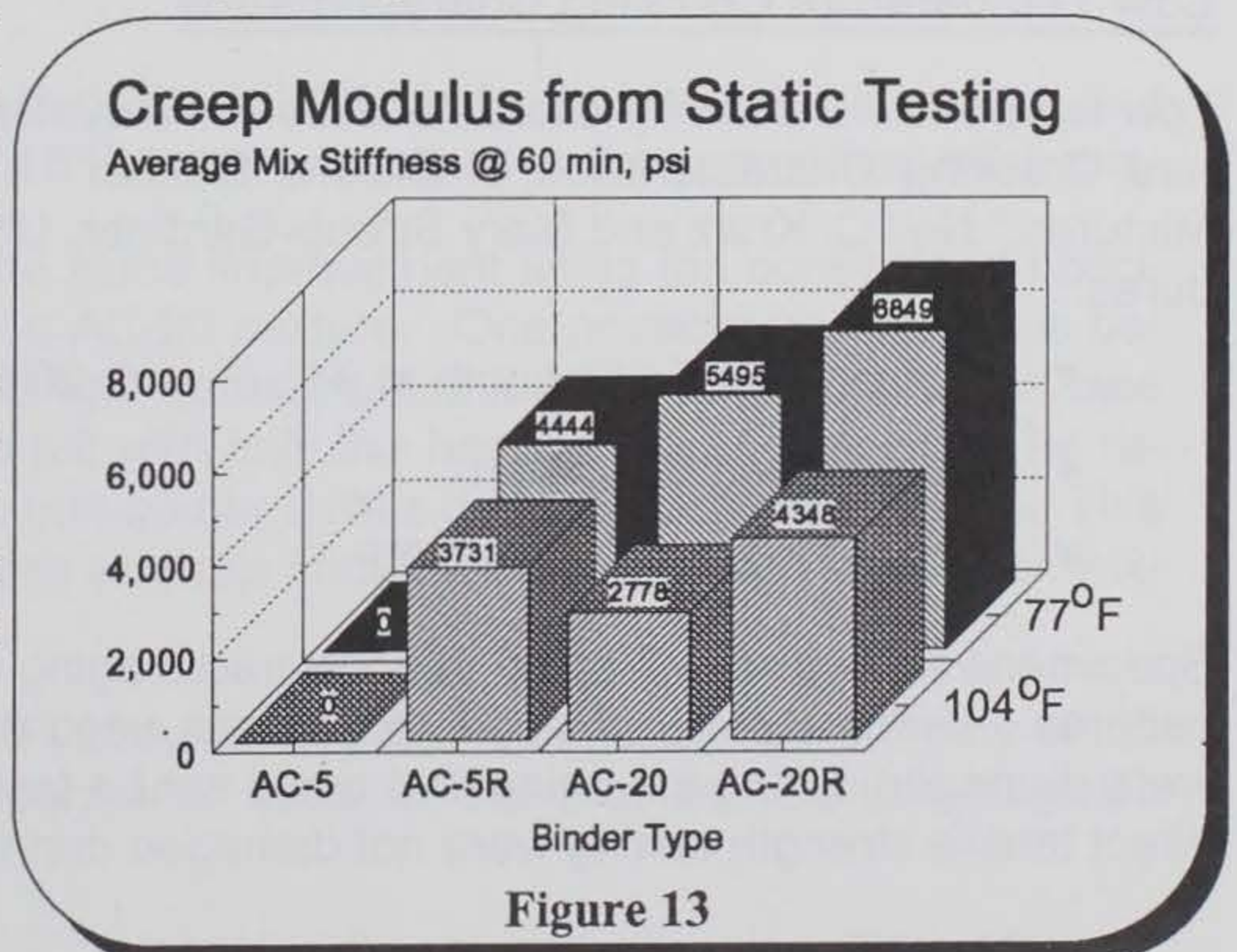
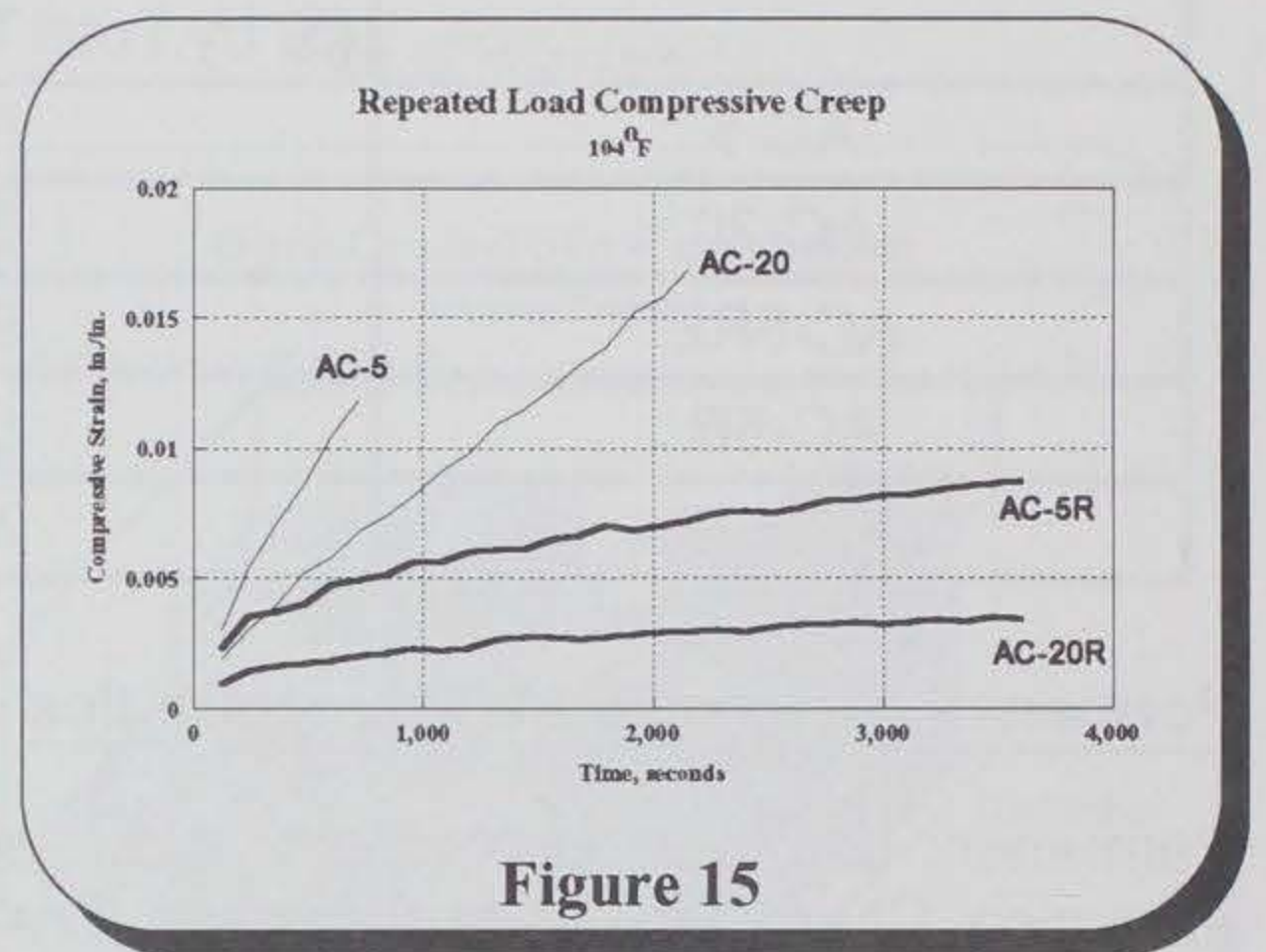
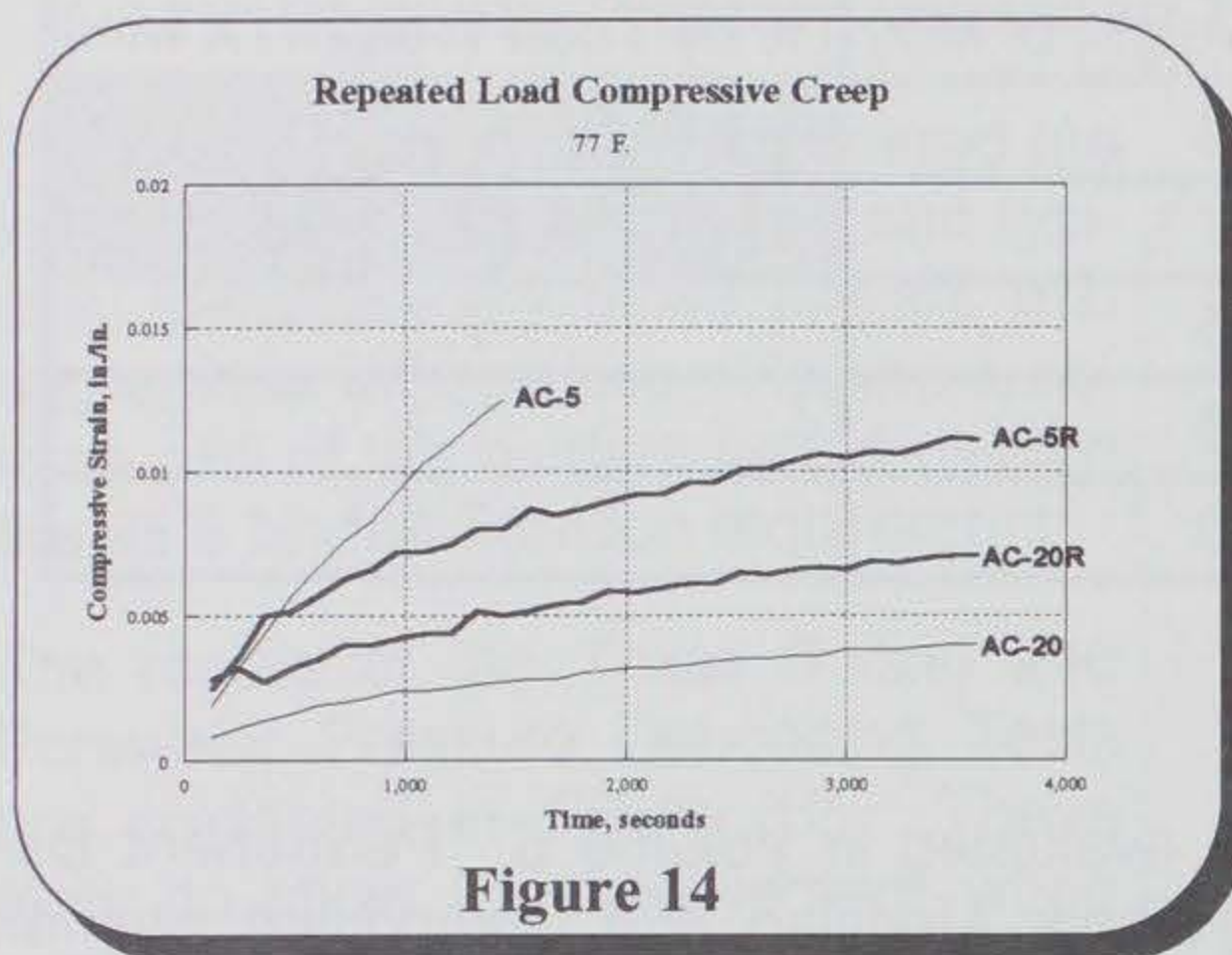

Figure 14 and 15 present the results of repeated load testing for four of the mixtures. At 77°F this testing shows the AC-20 to be most resistant to permanent deformation. However, at 104°F the asphalt-rubber mixes have the best performance and the deformation resistance of the AC-20 mixture is considerably reduced. This illustrates that testing at temperatures lower than the pavement may experience in service may not adequately predict the pavements resistance to permanent deformation. Therefore, permanent deformation testing should be performed at elevated temperatures. This conclusion is also supported by both the static and dynamic creep tests.



Repeated loading should be used for permanent deformation testing. This provides a better model by simulating moving wheel loads and is supported by comparing the static and repeated load tests at 104°F. The static test results indicate only the presence of rubber and nothing about the properties of the base binder. The repeated load testing indicates, in a concrete manner, the differences that exist between binders.

Low Temperature Cracking Characteristics

Low temperature cracking characteristics were evaluated in Volume 6, "Low Temperature Cracking Characteristics of Ground Rubber and Unmodified Asphalt Concrete Mixtures," Neil C. Krutz and Mary Stroup-Gardiner, UNR, using the following test procedures:

- Indirect Tensile Strength at 34°, 0° and -20°F.
- Constrained Specimen.
- Direct Tension Test at -20°F.

Specimens were also subjected to accelerated aging using NCHRP 9-6(1) AAMAS procedures. Unfortunately all beam specimens used for the constrained specimen test were damaged during the aging and could not be tested. The briquets used for the indirect tensile strength testing were not damaged during the accelerated aging.

The results of indirect tensile strength tests are presented in Figure 16. It should be noted that the specimens with asphalt-rubber took about twice as long to fail as the unmodified mixes. Since this is a constant strain test, the strains at failure for the asphalt-rubber mixes would be about twice that of the unmodified mixtures. This helps illustrate the conclusion that asphalt-rubber mixtures will exhibit more deformation at cold temperatures (i.e. 0°F and -20°F) while maintaining strengths similar to unmodified mixes.

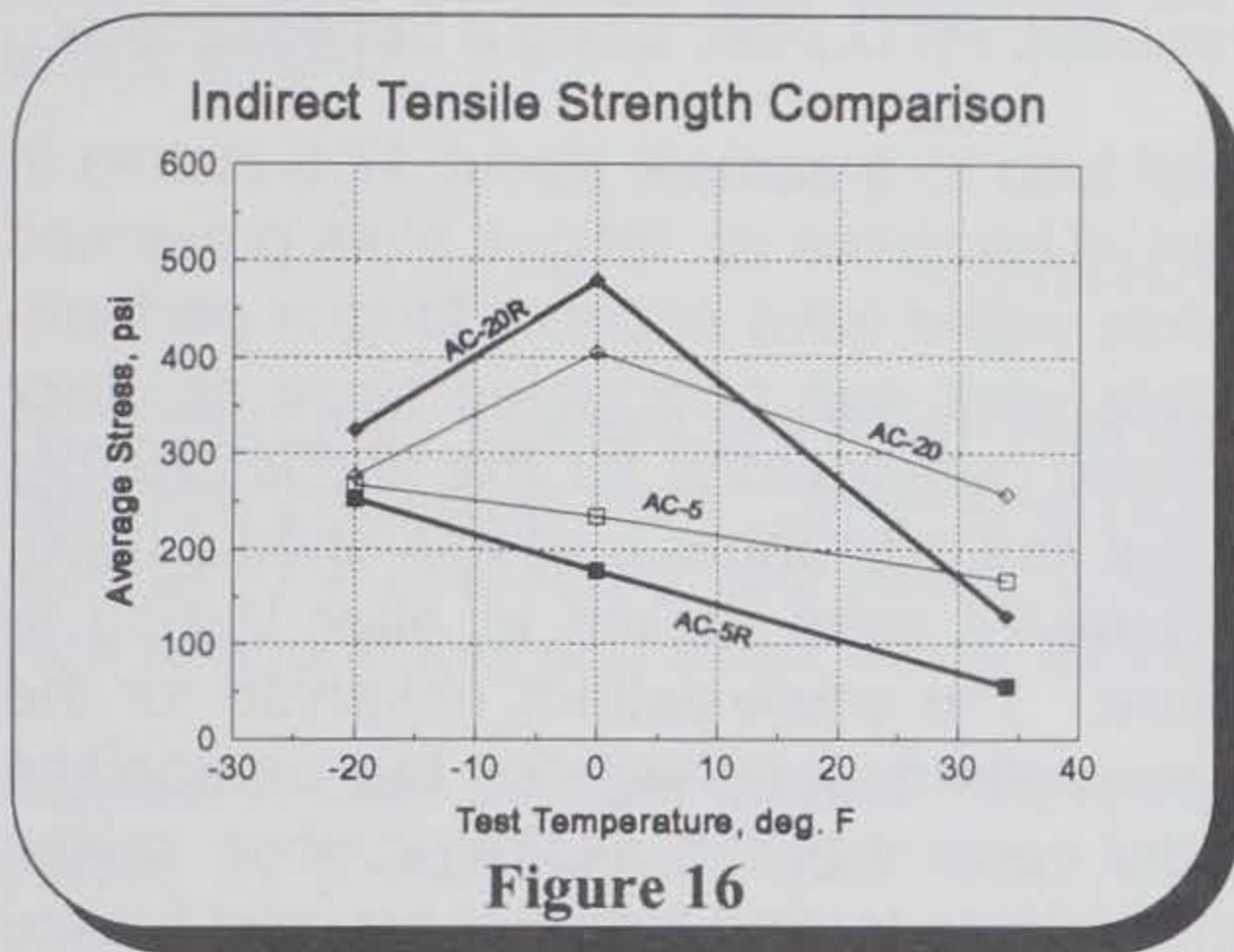

Figure 16

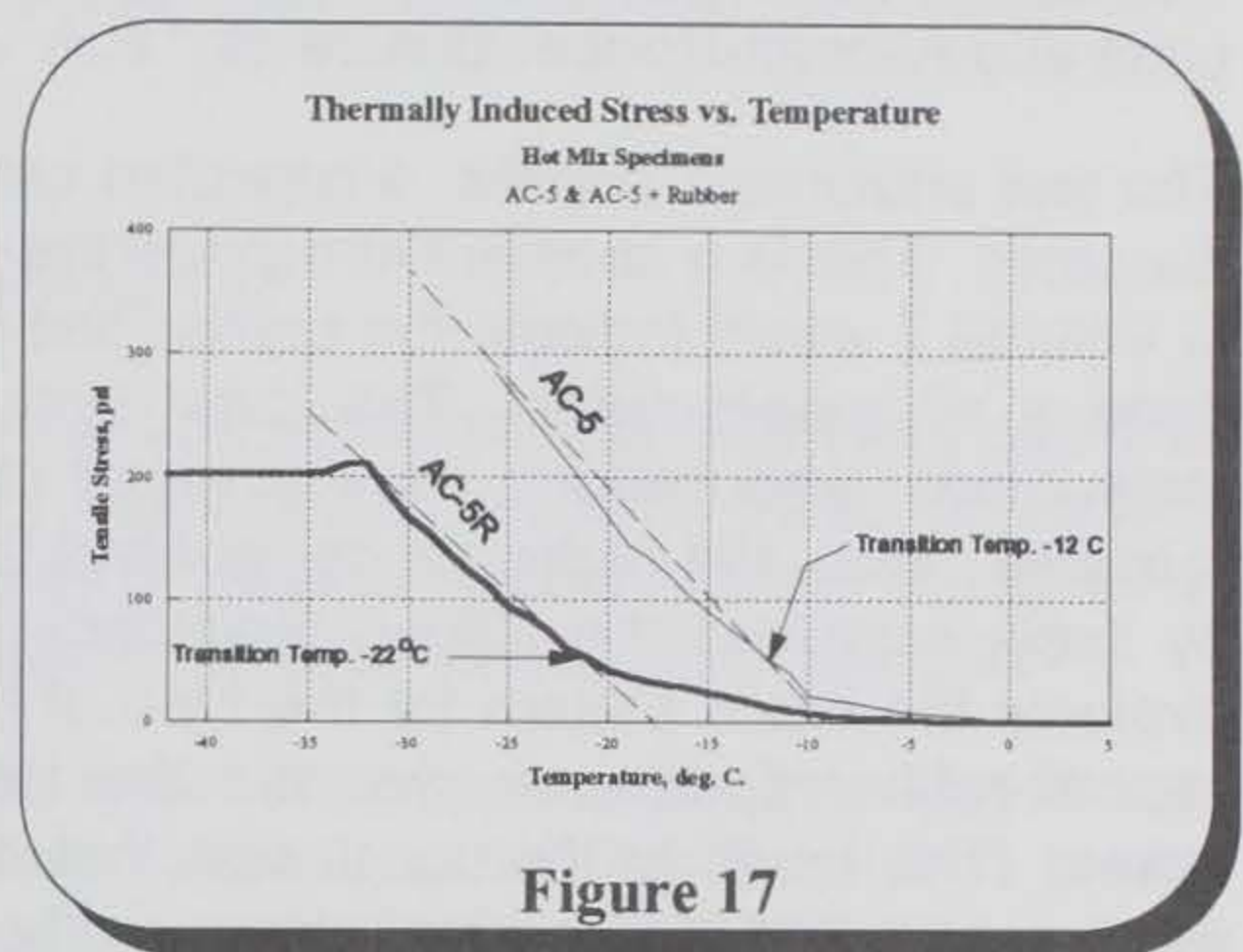

Figure 17

The constrained specimen testing measures the stress required to maintain a specimen at constant length under a constant rate of cooling. Figure 17 shows the results of the testing for specimens prepared using AC-5 and AC-5R binders. This illustrates that as the temperature drops the stress increases gradually until the "transition temperature" is reached and the stress increases at an accelerated rate. Above the "transition temperature" the mixes still possess viscoelastic properties where the thermal stresses can be relieved through stress relaxation. Below this "transition temperature" the mixture exhibits purely elastic characteristics and the thermal stresses are not relaxed until failure of the specimen.

Figure 17 illustrates the conclusion that the AC-5R binder reduces the transition and fracture temperature by about 10°C (18°F) when compared to the unmodified AC-5 mix.

The AC-20R sample did not show the same improvement using the constrained specimen test compared to the unmodified AC-20 mixture. One possible conclusion is because the rubber particles absorb the light fraction of the asphalt cement, a stiffer base asphalt, such as the AC-20, may be left with only the heavier oils and resins. The resulting mix may be more sensitive to non-homogenities due to increased stiffness. This leads to the conclusion that softer base asphalts should be used for asphalt-rubber mixtures for thermal cracking conditions.

Direct tensile tests conducted at -20°F, showed very little difference between any of the mixtures. This test at very low temperatures does not seem to be able to distinguish the difference in binders.

Little difference was observed in the aging of the AC-5 and AC-5R mixtures. Both mixtures exhibited approximately a 25 percent increase in indirect tensile strength after aging.

Fatigue of Asphalt and Asphalt-Rubber Concrete

The fatigue characteristics of the mixtures were evaluated in Volume 7, "Fatigue of Asphalt and Asphalt-Rubber Concretes," R.A. Jimenez, Ph.D., UA, using a deflectometer.

The test equipment applies a repeated central load to a sample about 17.5 inches in diameter. This is a constant stress fatigue test. The stress vs. fatigue plots presented in Volume 7 would indicate the unmodified mixes would have superior fatigue performance at all temperatures. This data contradicts what was anticipated since all other tests, binder and mixture, showed equal or better performance for the asphalt-rubber mixtures. Also, the higher binder content for the asphalt-rubber mixtures should have, by itself, improved the fatigue resistance. Samples were looked at after testing to evaluate the crack pattern for the type of failure. The crack pattern observed for the asphalt-rubber specimens was not the fatigue pattern observed for the unmodified mixes. This leads to the conclusion that binder content of the asphalt-rubber mixes was too high and the constant stress method of fatigue testing may not be valid for the asphalt-rubber modified mixtures.

Figure 18 shows the strain vs. repetitions to failure for mixtures with AC-5R and AC-20 binders. These plots were calculated by the author of this summary chapter using

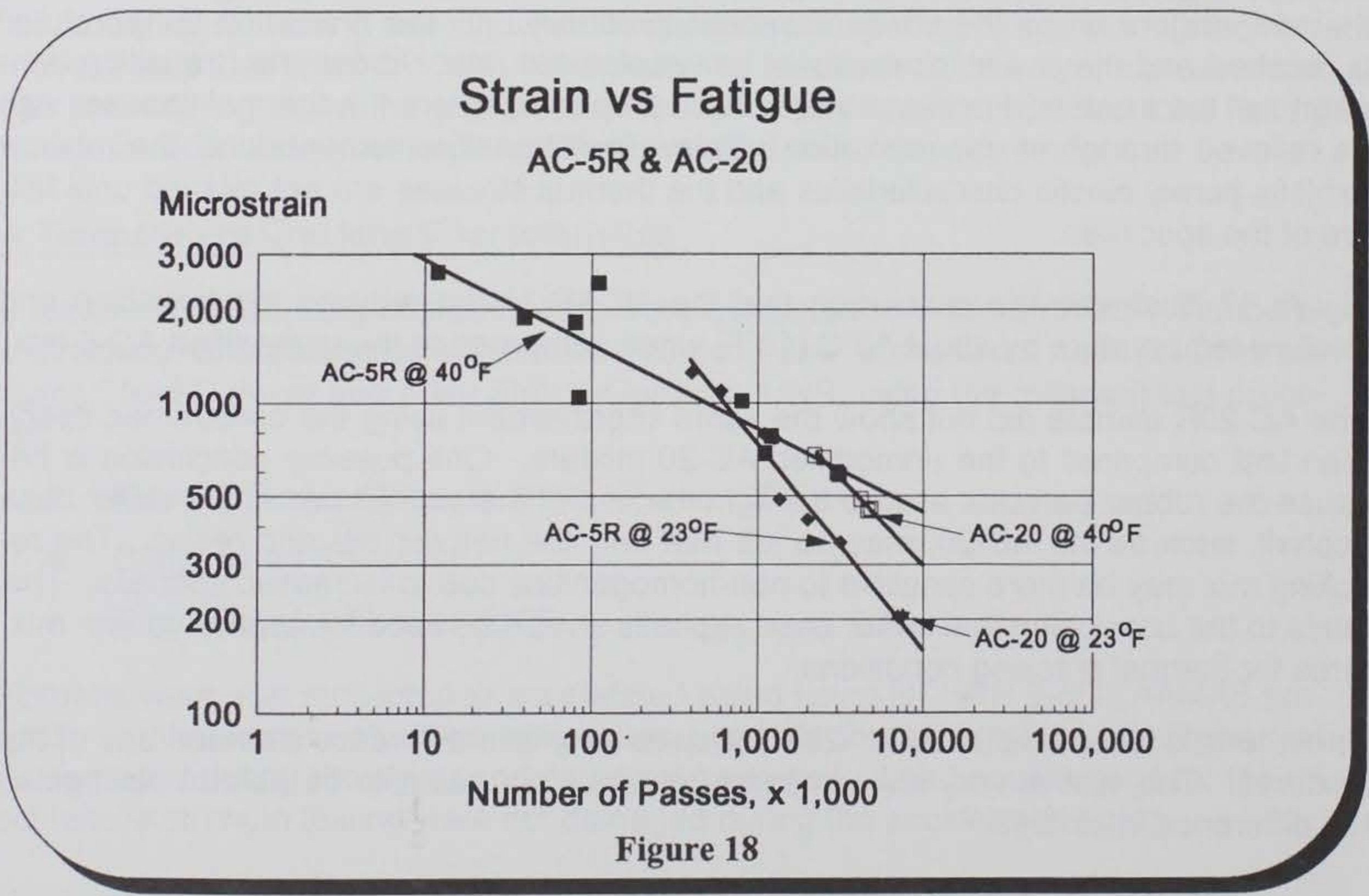

Figure 18

equations and modulus and test values presented in Volume 7. The plotted strain values were limited to an equivalent stress value of 300 psi. This maximum stress value keeps the plot within the stress values tested and the probable maximum tensile strength of the mixes. Like the stress vs. fatigue plots presented in Volume 7 this plot shows equal or superior performance for the AC-5R mixes especially at lower strains (lower stresses). The ability of the unmodified mixes to tolerate the higher strains the asphalt-rubber mixes were tested at is unknown. This plot indicates that asphalt-rubber mixes should be tested and evaluated using controlled strain testing rather than controlled stress.

CONCLUSIONS

Asphalt-rubber binders are much less temperature sensitive than the base asphalts they are produced from. This conclusion is supported by viscosity tests, penetration tests at 77°F and 39.2°F and tensile creep testing. Asphalt-rubber binders are stiffer at high temperatures and softer at low temperatures than the base asphalt cements.

Asphalt-rubber binders should be produced with softer base asphalts. This is supported by a number of binder tests including softening point, resilience and tensile creep. All of these binder tests show an asphalt-rubber binder produced with an AC-5 asphalt cement to have equal or better high temperature characteristics than an AC-20. Penetration and tensile creep tests show the asphalt-rubber produced with an AC-5 to have superior low temperature properties compared to an AC-20. This conclusion is also supported by permanent deformation and low temperature cracking testing of the dense graded mixes. This testing shows that an asphalt-rubber dense graded mix produced with an AC-5 base asphalt is more resistant to permanent deformation at high temperatures and more resistant to thermal cracking at low temperatures than a dense graded mix produced with an unmodified AC-20 or AC-5 asphalt cement.

Asphalt-rubber binders generally showed improved resistance to plant (TFOT) and environmental aging (Weatherometer). Only the viscosity testing of aged binders showed poorer aging for the AC-5RE binder which is produced from an AC-5 base asphalt and extender oil. Penetration testing of the aged binders showed less aging for all asphalt-rubber binders compared to their base asphalt cements.

Asphalt-rubber concrete (ARC) mixes can be designed using Marshall and Hveem procedures with slight modifications. Modifications to the mixing and compaction procedures include: mixing and compaction at higher temperatures than for neat asphalt cements; and allowing the samples to cool before extruding from the molds to prevent volumetric changes in the plugs due to elastic rebound of the rubber.

- For Marshall mix designs, asphalt-rubber mixes can be expected to have lower stability and unit weights, and higher VMA and flow than unmodified mixtures. It is recommended that flow limits for dense graded mixes be increased to 22 to 24.

- The Hveem stability should be reduced for asphalt-rubber mixes.
- Higher binder contents should be anticipated for asphalt-rubber mixes compared to mixes using neat asphalt cement, regardless of design method.

Testing indicates that asphalt-rubber open-graded friction courses would be more durable, longer lasting and better draining than unmodified open-graded friction courses.

Asphalt-rubber concrete mixes show improved resistance to permanent deformation at high temperatures than unmodified mixes.

Permanent deformation testing should be conducted at high temperature (100°F +) and use repeated loading.

The use of asphalt-rubber in dense graded mixes shows improved low temperature crack resistance compared to unmodified mixes. The use of softer base asphalts (AC-5) for the asphalt-rubber provided the most improvement in low temperature crack resistance.

Chapter 2

Summary Report of Physical Properties and Aging Characteristics of Asphalt-Rubber Binders

By

Gary Anderton
Department of the Army
Waterways Experiment Station
Corps of Engineers
Vicksburg, Mississippi

Table of Contents

BACKGROUND	21
OBJECTIVE	21
TEST METHODS	22
Phase I - Binder Tests	22
Viscosity	22
Penetration	23
Ductility	24
Softening Point	24
Resiliency	24
Phase II - Accelerated Aging Tests	25
Thin Film Oven	25
Weatherometer	25
SUMMARY OF TEST RESULTS	26
Conclusions	27
Recommendations	29

List of Tables

Table 1: Phase I Binder Test Results	27
Table 2: Phase II Accelerated Aging Test Results	28

PHYSICAL PROPERTIES AND AGING CHARACTERISTICS
OF ASPHALT RUBBER BINDERS

BACKGROUND

Asphalt-rubber binders were analyzed in this portion of the research program to determine their physical properties and aging characteristics in comparison with standard asphalt cements. The term "asphalt-rubber", as it is used in this study, refers to a blend of ground tire rubber and asphalt cement at elevated temperatures. The blend consists of about 15 to 25 percent ground tire rubber by total weight of the blend, which is added to the asphalt cement and allowed to "react" at an elevated mixing temperature before use as a pavement binder. This reaction phase involves a combined chemical and physical reaction between the asphalt cement and rubber which results in a more viscous and elastic binder containing individual rubber particles suspended throughout the binder. The rubber particles swell during this reaction, as they absorb some of the lighter distillants from the asphalt cement.

The test binders used in all of the tests of this study included three unmodified asphalt cements and three asphalt-rubber binders. A low, medium, and high viscosity binder was represented in the asphalt cement group as well as the asphalt-rubber binders. The asphalt cements used in this study included an AC-5, AC-20, and AC-40 grade. All of the asphalt-rubber binders contained the same ground rubber which had been reclaimed from waste tires. The AC-5 asphalt cement was blended with 16 percent rubber and 5 percent extender oil to make the test binder labeled AC-5RE. The same AC-5 asphalt cement was blended with 17 percent rubber, and the resulting binder was labeled AC-5R. The last asphalt-rubber binder used in this study was made by blending the AC-20 asphalt cement with 17 percent rubber, and the resulting binder was labeled AC-20R.

OBJECTIVE

The objective of this research was to determine the potential benefits of asphalt-rubber binders when used in hot mix asphalt (HMA) mixtures and to recommend the asphalt-rubber types required to achieve optimum field performance.

SCOPE

The binder tests were used to determine high temperature and low temperature engineering properties which helped to develop mixing and construction guidance as well as pavement performance predictions. The binder tests included:

- Kinematic Viscosity @ 275°F
- Absolute Viscosity @ 140°F
- Brookfield Viscosity @ 194°F, 221°F, 250°F, 275°F
- Haake Viscosity @ 194°F, 221°F, 250°F, 275°F
- Penetration @ 39°F, 77°F
- Cone Penetration @ 39°F, 77°F
- Ductility @ 39°F, 77°F
- Ring and Ball Softening Point
- Resiliency

In addition to the binder tests noted above, which were conducted on virgin materials, several binder tests were conducted on all six test binders after aging in the Thin-Film Oven and the Weatherometer. The Thin-Film Oven uses the traditional heat-aging approach while the Weatherometer imparts cycles of heat, ultraviolet radiation, and moisture to the test samples. The tests conducted on the aged binders included:

- Absolute Viscosity @ 140°F
- Penetration @ 77°F
- Ductility @ 77°F
- Ring and Ball Softening Point
- Percent Weight Loss

TEST METHODS

Numerous asphalt binder tests were conducted in the laboratory to determine the effectiveness of asphalt-rubber binders in HMA mixtures. Standard test methods and a number of specialized testing procedures were employed in this laboratory study. The test plan of this study was organized into two phases: Phase I included the binder tests on virgin materials, and Phase II included the aged binder tests.

Phase I - Binder Tests

Viscosity

Perhaps the most important physical property that can be determined of an asphalt binder is its viscosity, which is a measure of its resistance to flow when in the liquid state. Viscosity measurements, when determined across a range of temperatures, directly relate to an asphalt mixture's mixing, construction and performance characteristics. The asphalt binder grading methods used throughout the world are all, at least in part, based on viscosity. Accurate determinations of asphalt-rubber viscosity are more difficult to obtain

in comparison with standard asphalt cements. This is true because asphalt-rubber binders are actually two-phase systems containing small rubber particles suspended in the asphalt cement. The presence of these rubber particles has been known to effect the viscosity measurements of asphalt-rubber binders when using standard test methods (1). The importance of having a reliable viscosity test method and the documented difficulties in measuring asphalt-rubber viscosities lead to the selection of four viscosity test methods for this study. These test methods included three industry standards, the kinematic, absolute, and Brookfield methods, and a new test method known as the Haake viscosity test.

The kinematic and absolute viscosity tests are prescribed by ASTM D2170 (2) and ASTM D2171 (2), respectively. Both test methods use capillary viscometer tubes submerged in temperature control baths, with the kinematic viscosity test conducted at 275°F and the absolute viscosity test conducted at 140°F. Kinematic viscosity relates to a binder's properties during asphalt mixture plant mixing and construction laydown. Absolute viscosity is relative to the binder's condition in the pavement during the peak high temperatures of the summer months. The Brookfield and Haake tests determine viscosity by measuring the binder's resistance to shearing forces imparted by a rotating spindle which is inserted in the liquefied binder. Both test methods can be conducted over any range of temperatures above the binder's solid to liquid transition range. The Brookfield viscosity test is described by ASTM D2994 (2) and makes use of a stationary testing apparatus. The Haake viscosity test involves the same principles as the Brookfield test, but it makes use of a recently designed, compact, portable, hand-held device. Of all four viscosity test methods evaluated by this study, the Haake method proved to be the quickest and most convenient to conduct.

Penetration

Two types of penetration tests were conducted on the six test binders in order to evaluate their relative consistency and the effects of reduced temperature on this measurement. The standard needle penetration test, which is specified by ASTM D5 (2), was conducted at two temperatures, 39°F and 77°F. The test involves measuring the penetration depth of a standard needle which is forced into an asphalt binder sample under a 100 g load for five seconds.

Since asphalt-rubber binders contain suspended particles of rubber, it is entirely possible for a standard penetration needle to inconsistently come into contact with these particles during the test. Therefore, another type of consistency test was needed which would theoretically eliminate this potential problem. The Cone Penetration Test (ASTM D217) (2) was selected for this purpose since the test method makes use of the same basic equipment and loading scheme, with the exception of the penetrating tool being different. A cone-shaped tool is substituted for the needle and the metal cone is forced into the asphalt binder sample under the same loading conditions and temperatures as for the needle penetration test. Since the cone is displacing a larger area of the sample during the test, it would eliminate any potential negative effects on testing reliability caused by the suspended rubber particles.

Ductility

A series of ductility tests (ASTM D113) (2) were run on all six test binders at two temperatures, 39°F and 77°F. The ductility test measures the distance that an asphalt binder briquette specimen will elongate before breaking when the specimen ends are pulled apart at a specified speed. The test samples are maintained at a specified temperature in the water bath where the sample remains during testing. In measuring the binder's elastic properties, the ductility test has been associated with a number of physical properties such as shear resistance, temperature susceptibility, and low-temperature pavement performance. Regardless of the physical property associated with ductility, higher ductility values are desired to help improve pavement performance.

Softening Point

The Ring and Ball Softening Point Test was used in this study to determine the temperature at which the test binders began the phase change between solid to liquid state. This temperature becomes important in warm climates when pavement temperatures approach the binder softening point temperature and the pavement becomes tender and unstable under traffic. In these conditions, a higher softening point temperature is more desirable. The Ring and Ball Method (ASTM D36) (2) measures this value by taking a brass ring filled with asphalt binder and suspending it in a beaker filled with water. A steel ball of specified dimensions and weight is placed in the center of the sample, then the water bath is heated at a controlled rate. When the asphalt binder softens, the ball and asphalt binder sink toward the bottom of the beaker. The softening point temperature is recorded at the instant the softened asphalt binder sinks the prescribed distance and touches the bottom plate.

Resiliency

The Resiliency Test (ASTM D3883) was included in this study to determine if the addition of ground crumb rubber to an asphalt binder would significantly affect the resulting binder's elastic resilience properties. To determine this elastic resilience property, the binder sample is first hot-poured into a container similar to that used for the penetration test. The specimen is air-cured for 24 hours prior to testing. The specimen is then conditioned in a 77°F water bath for one hour where it will remain throughout the testing. A ball penetration tool is substituted for the needle on a standard penetrometer and forced into the asphalt specimen until a specified penetration depth is reached. The load on the penetration ball is held for 20 seconds, then released, with only the dead weight of the penetration ball and loading arm resting on the sample. The resulting elastic deformation recovery is recorded at two minutes after the load is released and the percentage of the original penetration depth is calculated. The recovery percentage gives an indication of the binder's elastic resilience properties with higher recovery values indicating a more durable binder in conditions of elastic strain.

Phase II - Accelerated Aging Tests

A series of binder tests were conducted in Phase II of this study on specimens which were conditioned in the laboratory by two types of accelerated aging test methods. The thin film oven test was used to determine the effects of short-term binder hardening which occurs when asphalt binders are mixed at high temperatures with hot aggregates at the asphalt plant. The effects of long-term age hardening, which occurs throughout the life of the pavement and results from continued exposure to the environment, were determined by aging the test binders in the weatherometer. The binder tests conducted on the laboratory-aged specimens included the 140°F absolute viscosity, 77°F penetration, 77°F ductility, and softening point tests. A weight loss percentage due to aging was also measured.

Thin Film Oven

The thin film oven test (ASTM D1754) (2) is conducted by placing a 50 gram sample of asphalt binder in a specified cylindrical flat-bottom pan, resulting in a specimen thickness of about 1/8 inch. The pan containing the binder specimen is placed on a rotating shelf in a 325°F oven. The oven shelf rotates at 5 to 6 revolutions per minute and the sample is kept in the oven for 5 hours. At this time, the specimen is removed from the oven and transferred to the specified container or mold necessary for further testing.

Weatherometer

The weatherometer is used to age laboratory specimens under environmental simulating conditions of ultraviolet (UV) radiation, moisture, and heat. These three elements are imposed on the specimens in automatically controlled cycles while in an environmentally controlled test chamber. The ultraviolet radiation is imparted by dual carbon arc lamps positioned in the center of the environmental chamber. Moisture effects are controlled by fine mist spray nozzles and humidity sensors. Thermostatically controlled heating elements within the test chamber control the test temperature. The test samples were placed in the same containers as used for the thin film oven test, but for the weatherometer tests, the containers were filled flush to the top to prevent water from collecting on top of the specimens. Up to eight specimens were placed on a wire mesh shelf located in the center area of the chamber and the shelf rotated at one revolution per minute during testing. The procedure used for aging the binder specimens in the weatherometer followed that prescribed by Federal Specification SS-S-00200b which specifies standard tests for pavement joint sealing materials. This standard describes the use of the weatherometer for accelerated aging of laboratory samples. Short-term aging is described as one day of weatherometer aging using 20 cycles of the following chamber conditions:

51 minutes UV light, then

9 minutes UV light with water spray

60 minutes total cycle time (140°F chamber temperature during entire conditioning period)

This 20 cycle test is conducted in one day's time. Long-term aging is simulated by repeating this same test for eight days under the same conditions. Both the one-day and eight-day tests were conducted in this study.

SUMMARY OF TEST RESULTS

The results of the Phase I binder tests are listed in Table 1. By comparing the Phase I test results of the asphalt-rubber binders to the test results of the asphalt cements, several performance predictions were formulated. The viscosity tests indicated that the asphalt-rubber binders tend to be less temperature susceptible and that higher than normal mixing and compaction temperatures would likely be necessary to handle these highly viscous binders. Both penetration tests supported the conclusion that asphalt-rubber binders offer reduced temperature susceptibility across a wide range of typical pavement service temperatures. The ductility test proved to be unsuitable for testing asphalt-rubber binders, therefore providing no comparative analysis. The softening point test results strongly suggested that the addition of rubber to asphalt cement would significantly reduce the chances of a HMA pavement becoming tender and unstable in warm climates. The resiliency test highlighted the superior elastic properties of the asphalt-rubber binders, indicating improved pavement durability and elastic recovery potential.

TABLE 1

PHASE I BINDER TEST RESULTS

TEST	AC-5	AC-20	AC-40	AC-5RE	AC-5R	AC-20R	
Kin Vis, 275°F (Cst)	141	265	358	NT	NT	NT	
Abs Vis, 140°F (P)	654	2390	4575	2027	3221	5773	
Brookfield Vis (P)	194°F	40	135	173	570	1980	1040
	221°F	18	20	30	215	243	233
	250°F	4	8	7	170	155	185
	275°F	3	4	6	83	88	93
Haake Vis (P)	194°F	10	40	80	350	150	350
	221°F	3	18	25	175	125	180
	250°F	2	6	9	125	112	137
	275°F	1	4	8	100	105	125
Penetration (0.1 mm)							
200g, 60 sec, 39°F	40	15	14	63	39	20	
100g, 5 sec, 77°F	114	44	27	125	85	40	
Cone Pen (0.1 mm)							
200g, 60 sec, 39°F	63	27	10	94	58	25	
150g, 5 sec, 77°F	101	35	21	111	71	38	
Ductility (cm)							
5 cm/min, 39°F	0	0	0	25.4	22.5	0.9	
5 cm/min, 77°F	150+	150+	150+	18.7	20.2	35.0	
Softening Pt. (°F)	112	129	134	133	143	151	
Resiliency (% Rec.)	-40	-9	-4	-20	11	32	

Note: NT = No Test

The results of the Phase II accelerated aging tests are listed in Table 2. The aged viscosity tests conducted during Phase II of this study indicated that the asphalt-rubber binders age-hardened about 50 percent less than their unmodified asphalt cement counterparts. The AC-5RE showed increased age-hardening in the viscosity test, however, and this was attributed to the evaporation of the extender oil additive. The aged penetration tests supported the implication that asphalt-rubber binders are less susceptible to all types of age-hardening. No significant change in softening point was measured for any of the test binders under any aging condition. The asphalt-rubber binders endured more weight loss as a group when compared to the asphalt cement binders. This was theorized to have been caused by the evaporation of a small amount of petroleum-based oil found in the tire rubber, but the amount of weight loss did not appear to significantly affect the other aging properties.

TABLE 2
PHASE II ACCELERATED AGING TEST RESULTS

Test	AC-5	AC-20	AC-40	AC-5RE	AC-SR	AC-20R
140°F Viscosity (P)						
Original	654	2390	4575	2027	3221	5773
TFOT Residue ^a	1196	4169	8532	4189	4302	8535
WO Res. 1 day ^b	814	2709	4872	3766	4075	6252
WO Res. 8 days	984	2983	5453	3837	4158	6330
77°F Penetration (0.1mm)						
Original	114	44	27	85	125	40
TFOT Residue	74	29	20	67	102	36
WO Res. 1 day	89	37	21	68	105	42
WO Res. 8 days	75	35	23	60	99	38
Softening Point (°F)						
original	112	129	134	143	133	151
TFOT Residue	117	131	138	147	132	148
WO Res. 1 day	115	130	136	149	134	149
WO Res. 8 days	120	132	139	146	137	154
Weight Loss (%)^c						
TFOT Residue	0.45	0.14	0.16	0.82	1.04	0.53
WO Res. 1 day	-0.06	-0.04	-0.05	-0.01	-0.01	-0.07
WO Res. 8 days	-24.2	-0.40	-0.20	-0.08	-0.01	-0.16

^a TFOT represents thin film oven test aging

^b WO represents weatherometer aging

^c Negative weight loss represents weight gain.

Conclusions

Based on the results of this study, the following conclusions were made on the physical properties of asphalt-rubber binders and their potential effectiveness when used in HMA pavements:

1. The addition of 16 to 17 percent ground reclaimed rubber to an asphalt cement will increase the binder viscosity by 100 to 2000 percent, depending upon the test method and test temperature.

2. Differing grades of asphalt-rubber binders produced with similar dosage levels of the same rubber have very similar viscosities above 200°F. This indicates that above about 200°F, the viscosity of the binder is controlled by the rubber and below 200°F, the base asphalt cement has a significant influence on binder viscosity.
3. The addition of reclaimed rubber improved low-temperature binder properties and reduced overall temperature susceptibilities as indicated by the penetration tests.
4. The ductility test is unsuitable for testing the type of asphalt-rubber binders represented in this study.
5. Softening points are increased by approximately 20 to 30°F by the addition of 16 to 17 percent reclaimed rubber. This means that asphalt-rubber HMA pavements should be less susceptible to traffic induced deformation distresses at high temperatures.
6. Asphalt-rubber binders have higher elastic recovery potentials than unmodified asphalt cement binders.
7. Asphalt-rubber binders harden 50 percent less than asphalt cement binders when aged by the thin film oven test. This means that the viscous properties of asphalt-rubber binders would be much more stable at the asphalt mixing plant. The exception to this is when an extender oil is added with the rubber to the asphalt cement, as a significant portion of extender oil will vaporize at normal HMA plant temperatures, causing sizeable increases in binder viscosity.
8. Environmental age-hardening is reduced by the addition of reclaimed rubber. The exception to this statement again is when an extender oil is added with the rubber. Enough extender oil was lost during the weatherometer aging process to cause comparatively higher age-hardening tendencies for the AC-5RE test binder.
9. The penetration test evaluation of the aged binders supported the conclusions reached by the aged viscosity analysis. Detrimental binder aging effects were reduced for the asphalt-rubber binders, except when an extender oil was used with the rubber addition.
10. Softening points of the asphalt cement and asphalt-rubber binders was relatively unchanged by the laboratory aging processes used in this study.
11. Asphalt-rubber binders had higher weight losses after thin film oven test aging when compared to the asphalt cement binders, but the amount of weight loss did not appear to significantly affect other aging properties.

Recommendations

Based on the conclusions derived from the results of this laboratory study, the following recommendations are made:

1. Asphalt-rubber binders can be used in HMA pavements to achieve any or all of the following pavement performance improvements:
 - a. Reduced temperature-susceptability
 - b. Reduced low-temperature cracking potential
 - c. Reduced high-temperature deformation distress potential
 - d. Reduced age-hardening from plant mixing temperatures and from exposure to the environment
2. Any asphalt cement grade between the AC-5 and AC-20 viscosity grades may be used in the production of asphalt-rubber binders. A good rule of thumb to follow in selecting the proper grade of asphalt cement is to use one grade lower than what is normally used. For instance, if an AC-20 is normally specified, then an AC-10 with rubber may be substituted. The use of extender oils with these binders will reduce viscosity, but may detrimentally effect the aging properties and other benefits achieved by the addition of reclaimed rubber.
3. Although the type and dosage level of reclaimed rubber used in this study is representative of the current technology, additional research needs to be conducted to evaluate the effects of different rubber reclaiming processes and dosage levels in the binder.

The first part of the paper discusses the importance of the study and the objectives of the research. It highlights the need for a comprehensive understanding of the subject matter and the role of the researcher in this process.

The second part of the paper focuses on the methodology used in the study. It details the research design, data collection methods, and the analysis techniques employed to ensure the validity and reliability of the findings.

The third part of the paper presents the results of the study. It discusses the key findings and their implications, providing a clear and concise summary of the research outcomes.

The fourth part of the paper discusses the conclusions drawn from the study. It reflects on the overall findings and their significance, offering insights into the broader context of the research.

The final part of the paper provides a summary of the research and offers suggestions for future studies. It emphasizes the need for continued exploration and research in this field to further advance our understanding of the subject matter.

Chapter 3

Summary Report of Tensile Creep Comparison of Asphalt Cement and Asphalt-Rubber Binders

by

**Kent R. Hansen
and
Anne Stonex
International Surfacing, Inc.**

Table of Contents

GENERAL	33
TESTING AND EVALUATION	33
CONCLUSIONS	34

List of Tables

TABLE A-9	Constant Load Creep Evaluation Data, AC-20 & Rubber, 22°F	37
TABLE A-13	Constant Load Creep Evaluation Data, AR-1000, 22°F	38

List of Figures

FIGURE 1	Diagram of Float and Sample Positioning	35
FIGURE 2	Creep Test Loading System	36
FIGURE B-1	Stiffness Modulus vs Time, AC-5 + 5% Extender Oil + 16% Rubber, 22°F	39
FIGURE B-21	Stiffness Modulus vs Time, AC-40, 55°F	40
FIGURE B-23	Modulus/Time Regression Constant "b" vs Strain	41
FIGURE C-2	Stiffness Modulus vs Time, AC-5 + 17% Rubber	42
FIGURE C-5	Stiffness Modulus vs Time, AC-20	43
FIGURE D-3	Stiffness Modulus vs Temperature, AC-5 and All Asphalt-Rubber Blends	44
FIGURE D-4	Stiffness Modulus vs Temperature, AC-20 and All Asphalt-Rubber Blends	45
FIGURE D-5	Stiffness Modulus vs Temperature, AC-40 and All Asphalt-Rubber Blends	46

SUMMARY REPORT

TENSILE CREEP COMPARISON OF ASPHALT CEMENT AND ASPHALT-RUBBER BINDERS

General

This report summarizes the report "Tensile Creep Comparison of Asphalt and Asphalt-Rubber Binders" by Kent Hansen and Anne Stonex, October 1991. Selected figures and tables from the complete report are provided to back up the conclusions of the report.

Testing and Evaluation

Tensile creep testing was performed on the three asphalt cements and three asphalt-rubber binders used in the CPAR Asphalt-Rubber study. The testing was performed using procedures reported by Coetzee and Monismith¹. Testing was performed at four temperatures (22°F, 39.2°F, 55°F and 77°F) in a modified ductility bath with a static load applied using a pulley system. Figures 1 and 2 show the testing configuration used.

Loads were selected to achieve a strain of 20 to 40 percent at 1,000 seconds. All asphalt cement samples had brittle failures at 22°F before achieving the desired strain. Of all the asphalt-rubber samples, only the AC-20R did not achieve the desired strain when tested at the maximum load of the test equipment. The AC-20R was still elastic and did not fail at this load. Tables A-9 and A-13 are provided to illustrate this condition and show recorded and calculated data.

After loading for 1,000 seconds the load was removed and the samples allowed to rebound. The asphalt-rubber samples averaged 24 percent recoverable strain. The AC-5R, which had the highest rubber content (17%), also averaged the highest recoverable strain, 28%. The AC-5RE and AC-20R, which had the same amount of rubber (16%), averaged 23% and 21% recoverable strain, respectively. The asphalt cement samples did not rebound.

The plots and regression analysis of the individual test results for stiffness modulus versus time indicated that the test is repeatable. Variations are greater for the unmodified asphalt cements at low temperatures. This is probably due to the low strain levels and accuracy of the measurements. Figures B-1 and B-21 are attached to show the range of test variations. Plots of the average stiffness modulus versus time for the AC-5 + Rubber and AC-20 are presented in Figures C-2 and C-5, respectively.

¹ Coetzee, N.F., and Monismith, C.L., "Analytical Study of Minimization of Reflective Cracking in Asphalt Concrete Overlays by use of a Rubber Asphalt Interlayer", Transportation Research Record 700, 1979, pp. 100-108.

Variations in the slope of the modulus versus time plots for the average test results are small for the different temperatures. Variations in the slope are primarily a function of the strain rate. A plot of the regression constant "b" versus strain at 1,000 seconds shows a correlation between the strain rate and slope of the modulus versus time plot for most of the binders tested. This plot is presented on Figure B-23.

Plots of the stiffness modulus versus temperature at 1,000 seconds show decreased temperature susceptibility of the asphalt-rubber binders. The asphalt-rubber binders show increased stiffness at higher temperatures and decreased stiffness at low temperatures when compared to the base asphalts. These plots are presented in Figures D-3, D-4 and D-5.

Conclusions

Asphalt-rubber binders show significantly less temperature susceptibility than conventional asphalt cement. The addition of rubber increases the high temperature stiffness of the binder and improves the low temperature flexibility. The high temperature improvements are shown in the plot of the stiffness modulus versus temperature. The improved low temperature flexibility is also shown on the graphs, but is best indicated by the fact that all the asphalt cement samples had brittle failures at low temperatures while all the asphalt-rubber samples remained flexible.

Similar high temperature stiffness may be achieved with an asphalt-rubber produced with an asphalt cement two to three grades softer than the neat asphalt-cement. This is best shown by modulus versus temperature plots where both the AC-5R and AC-20R are stiffer than the AC-40 above 85°F. The low temperature properties are much better for the asphalt-rubber samples than the straight AC-40.

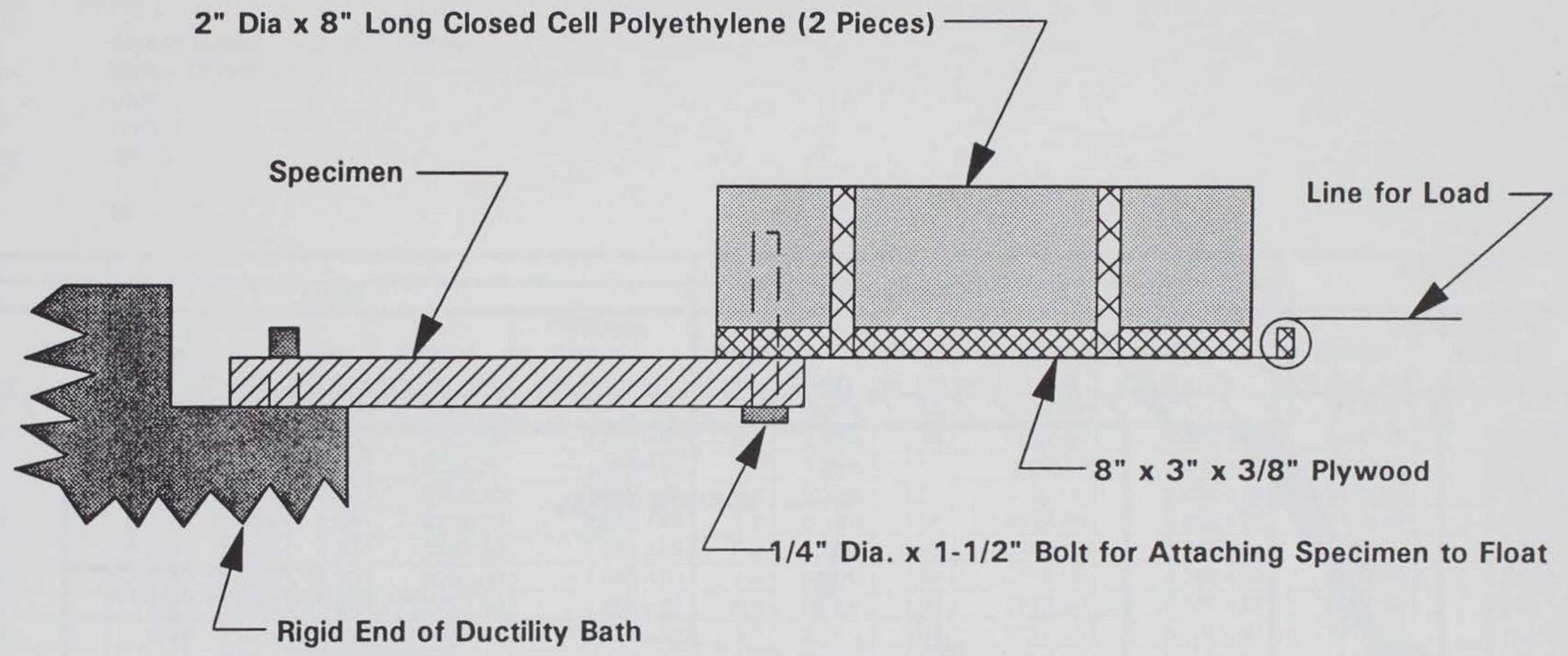

Figure 1. Diagram of Float and Sample Positioning

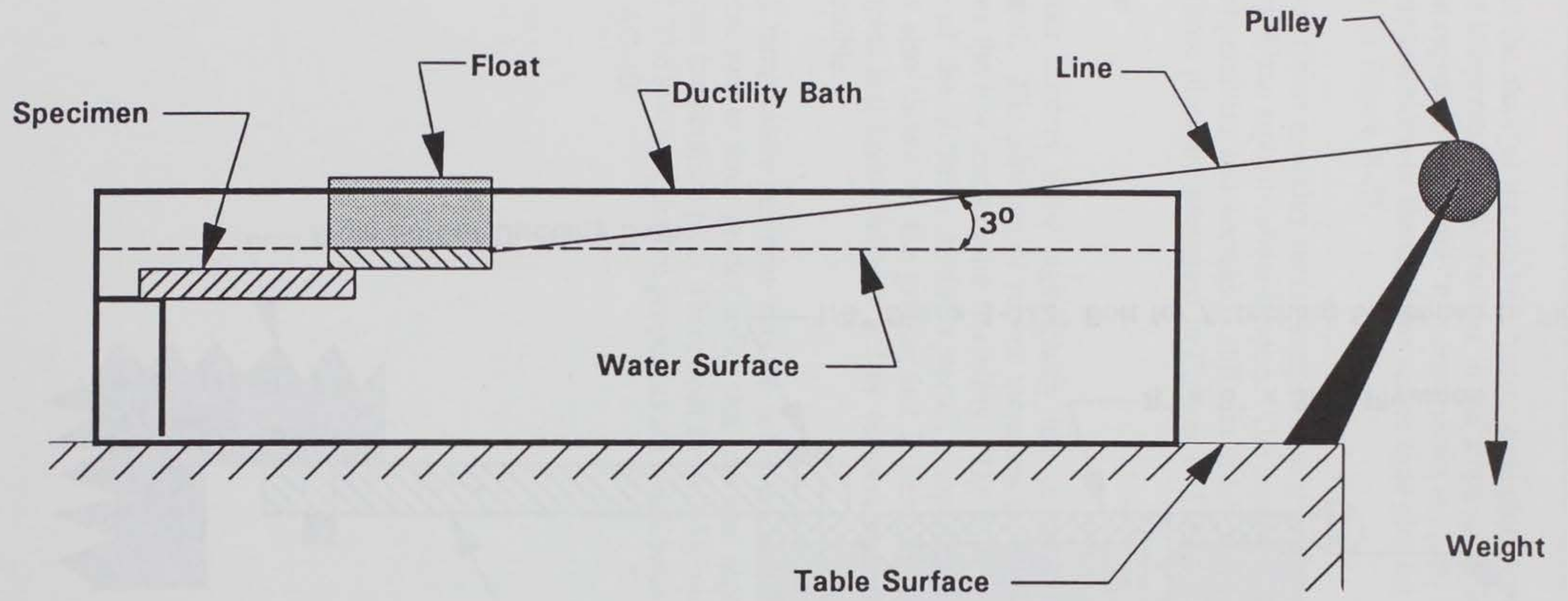

Figure 2: Creep Test Loading System

TABLE A-9
Constant Load Creep Evaluation Data

Lab Report No. ARPG-91-9
 Work Order No. ARPG-005
 Report Date 04/23/91

Material Asphalt Rubber – AC-20 & Rubber
 Identification UNR – CPAR Project
 Source UNR
 Sampled By UNR
 Requested By ARPG

TEMP, F 22 +- 1F

REPLICATE	1					2					AVERAGE	
LOAD, gms	10000					10000						
Time	Gage cm	Strain	Area sq. cm	Stress gm./sq. cm	Stiffness Modulus gm./sq.cm.	Gage cm	Strain	Area sq. cm	Stress gm./sq. cm.	Stiffness Modulus gm./sq.cm.	Stress gm./sq. cm.	Stiffness Modulus gm./sq.cm.
O	8.0	0.00%	2.00	5000.00		8.0	0.00%	2.00	5000.00		5000.00	
10S	8.2	2.50%	1.95	5125.00	2.05E+05	8.1	1.25%	1.98	5062.50	4.05E+05	5093.75	3.05E+05
30S	8.2	2.50%	1.95	5125.00	2.05E+05	8.1	1.25%	1.98	5062.50	4.05E+05	5093.75	3.05E+05
1M	8.2	2.50%	1.95	5125.00	2.05E+05	8.2	2.50%	1.95	5125.00	2.05E+05	5125.00	2.05E+05
2M	8.2	2.50%	1.95	5125.00	2.05E+05	8.2	2.50%	1.95	5125.00	2.05E+05	5125.00	2.05E+05
3M	8.3	3.75%	1.93	5187.50	1.38E+05	8.3	3.75%	1.93	5187.50	1.38E+05	5187.50	1.38E+05
4M	8.4	5.00%	1.90	5250.00	1.05E+05	8.4	5.00%	1.90	5250.00	1.05E+05	5250.00	1.05E+05
5M	8.4	5.00%	1.90	5250.00	1.05E+05	8.5	6.25%	1.88	5312.50	8.50E+04	5281.25	9.50E+04
6M	8.5	6.25%	1.88	5312.50	8.50E+04	8.5	6.25%	1.88	5312.50	8.50E+04	5312.50	8.50E+04
7M	8.6	7.50%	1.86	5375.00	7.17E+04	8.6	7.50%	1.86	5375.00	7.17E+04	5375.00	7.17E+04
8M	8.6	7.50%	1.86	5375.00	7.17E+04	8.6	7.50%	1.86	5375.00	7.17E+04	5375.00	7.17E+04
9M	8.6	7.50%	1.86	5375.00	7.17E+04	8.7	8.75%	1.84	5437.50	6.21E+04	5406.25	6.69E+04
10M	8.7	8.75%	1.84	5437.50	6.21E+04	8.7	8.75%	1.84	5437.50	6.21E+04	5437.50	6.21E+04
11M	8.7	8.75%	1.84	5437.50	6.21E+04	8.7	8.75%	1.84	5437.50	6.21E+04	5437.50	6.21E+04
12M	8.8	10.00%	1.82	5500.00	5.50E+04	8.7	8.75%	1.84	5437.50	6.21E+04	5468.75	5.86E+04
13M	8.8	10.00%	1.82	5500.00	5.50E+04	8.8	10.00%	1.82	5500.00	5.50E+04	5500.00	5.50E+04
14M	8.9	11.25%	1.80	5562.50	4.94E+04	8.8	10.00%	1.82	5500.00	5.50E+04	5531.25	5.22E+04
15M	8.9	11.25%	1.80	5562.50	4.94E+04	8.9	11.25%	1.80	5562.50	4.94E+04	5562.50	4.94E+04
16M	8.9	11.25%	1.80	5562.50	4.94E+04	8.9	11.25%	1.80	5562.50	4.94E+04	5562.50	4.94E+04
1000S	9.0	12.50%	1.78	5625.00	4.50E+04	9.0	12.50%	1.78	5625.00	4.50E+04	5625.00	4.50E+04
1M	8.9	11.25%	1.80	0		8.9	11.25%	1.80	0		0.00	
2M	8.8	10.00%	1.82	0		8.8	10.00%	1.82	0		0.00	
3M	8.8	10.00%	1.82	0		8.8	10.00%	1.82	0		0.00	
4M	8.8	10.00%	1.82	0		8.8	10.00%	1.82	0		0.00	
5M	8.8	10.00%	1.82	0		8.8	10.00%	1.82	0		0.00	
FINAL MEASURED AREA, sq.cm.				1.44					1.44			

27

TABLE A-13
Constant Load Creep Evaluation Data

Lab Report No. ARPG-91-12
Work Order No. ARPG-005
Report Date 04/23/91

Material Asphalt Cement - Witco AR-1000 (AC-5)
Identification UNR
Source UNR
Sampled By UNR
Requested By ARPG

TEMPERATURE, F 22 +- 1F

REPLICATE	1					2					AVERAGE	
LOAD, gms	2000					2000						
Time	Gage cm	Strain	Area sq. cm	Stress gm./sq. cm	Stiffness Modulus gm./sq.cm.	Gage cm	Strain	Area sq. cm	Stress gm./sq. cm.	Stiffness Modulus gm./sq.cm.	Stress gm./sq. cm	Stiffness Modulus gm./sq.cm.
0	8.0	0.00%	1.71	1169.59		8.0	0.00%	1.80	1111.11		1140.35	
10S	8.1	1.25%	0.19	10643.27	8.51E+05	8.1	1.25%	0.20	10111.11	8.09E+05	10377.19	8.30E+05
30S	8.1	1.25%	0.19	10643.27	8.51E+05	8.1	1.25%	0.20	10111.11	8.09E+05	10377.19	8.30E+05
1M	8.1	1.25%	0.19	10643.27	8.51E+05	8.1	1.25%	0.20	10111.11	8.09E+05	10377.19	8.30E+05
2M	8.2	2.50%	0.19	10760.23	4.30E+05	8.1	1.25%	0.20	10111.11	8.09E+05	10435.67	6.20E+05
3M	8.2	2.50%	0.19	10760.23	4.30E+05	8.1	1.25%	0.20	10111.11	8.09E+05	10435.67	6.20E+05
4M	8.2	2.50%	0.19	10760.23	4.30E+05	8.1	1.25%	0.20	10111.11	8.09E+05	10435.67	6.20E+05
5M	8.2	2.50%	0.19	10760.23	4.30E+05	8.1	1.25%	0.20	10111.11	8.09E+05	10435.67	6.20E+05
6M	8.2	2.50%	0.19	10760.23	4.30E+05	8.2	2.50%	0.20	10222.22	4.09E+05	10491.23	4.20E+05
7M	8.2	2.50%	0.19	10760.23	4.30E+05	8.2	2.50%	0.20	10222.22	4.09E+05	10491.23	4.20E+05
8M	8.2	2.50%	0.19	10760.23	4.30E+05	8.2	2.50%	0.20	10222.22	4.09E+05	10491.23	4.20E+05
9M	8.3	3.75%	0.18	10877.19	2.90E+05	8.3	3.75%	0.19	10333.33	2.76E+05	10605.26	2.83E+05
10M	8.3	3.75%	0.18	10877.19	2.90E+05	8.3	3.75%	0.19	10333.33	2.76E+05	10605.26	2.83E+05
11M	8.3	3.75%	0.18	10877.19	2.90E+05	8.3	3.75%	0.19	10333.33	2.76E+05	10605.26	2.83E+05
12M	8.4	5.00%	0.18	10994.15	2.20E+05	8.3	3.75%	0.19	10333.33	2.76E+05	10663.74	2.48E+05
13M	8.4	5.00%	0.18	10994.15	2.20E+05	8.3	3.75%	0.19	10333.33	2.76E+05	10663.74	2.48E+05
14M	8.4	5.00%	0.18	10994.15	2.20E+05	8.4	5.00%	0.19	10444.44	2.09E+05	10719.30	2.14E+05
15M	8.5	6.25%	0.18	11111.11	1.78E+05	8.4	5.00%	0.19	10444.44	2.09E+05	10777.78	1.93E+05
16M	8.5	6.25%	0.18	11111.11	1.78E+05	8.4	5.00%	0.19	10444.44	2.09E+05	10777.78	1.93E+05
1000S	8.5	6.25%	0.18	11111.11	1.78E+05	8.5	6.25%	0.19	10555.56	1.69E+05	10833.33	1.73E+05
1M	8.5	6.25%	0.18	0		8.5	6.25%	0.19	0		0.00	
2M	8.5	6.25%	0.18	0		8.5	6.25%	0.19	0		0.00	
3M	8.5	6.25%	0.18	0		8.5	6.25%	0.19	0		0.00	
4M	8.5	6.25%	0.18	0		8.5	6.25%	0.19	0		0.00	
5M	8.5	6.25%	0.18	0		8.5	6.25%	0.19	0		0.00	
FINAL MEASURED AREA, sq.cm.			1.71					1.8				

STIFFNESS MODULUS vs TIME

AC-5 + 5% Extender Oil + 16% Rubber

22 F.

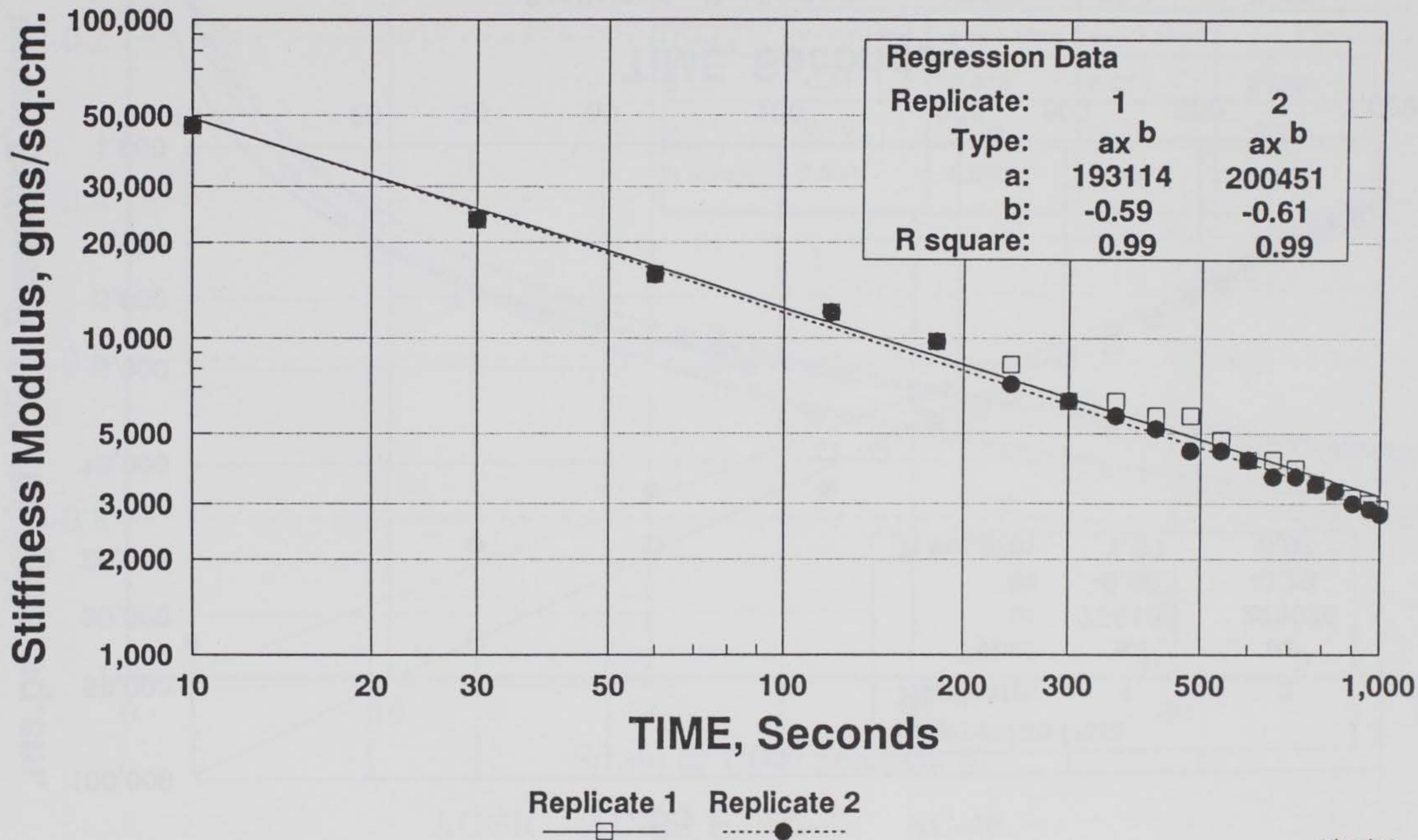

39

8/26/91

FIGURE B-1

STIFFNESS MODULUS vs TIME

AC-40

55 F.

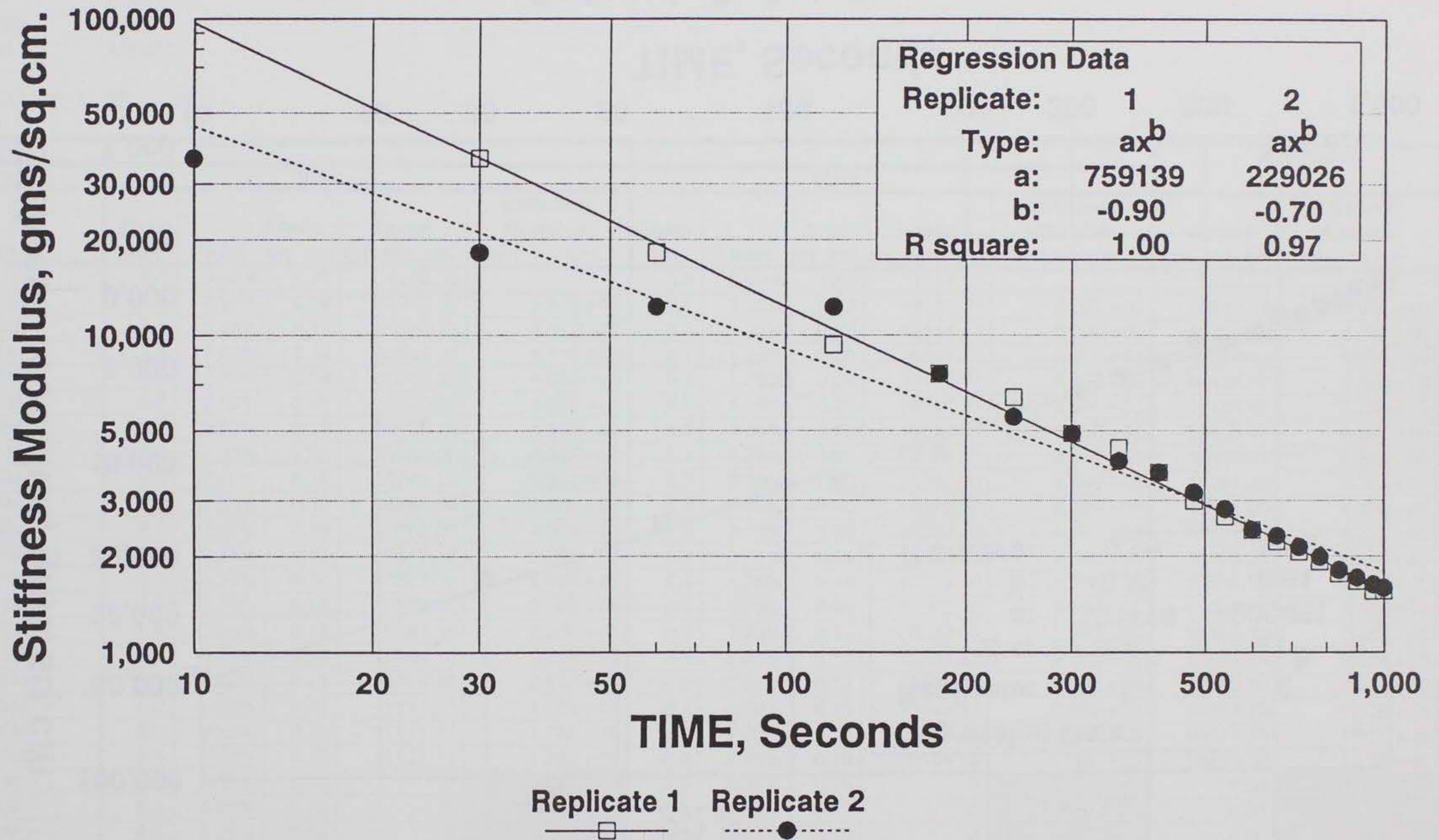

40

8/27/91

FIGURE B-21

MODULUS/TIME REGRESSION CONSTANT "b" vs STRAIN

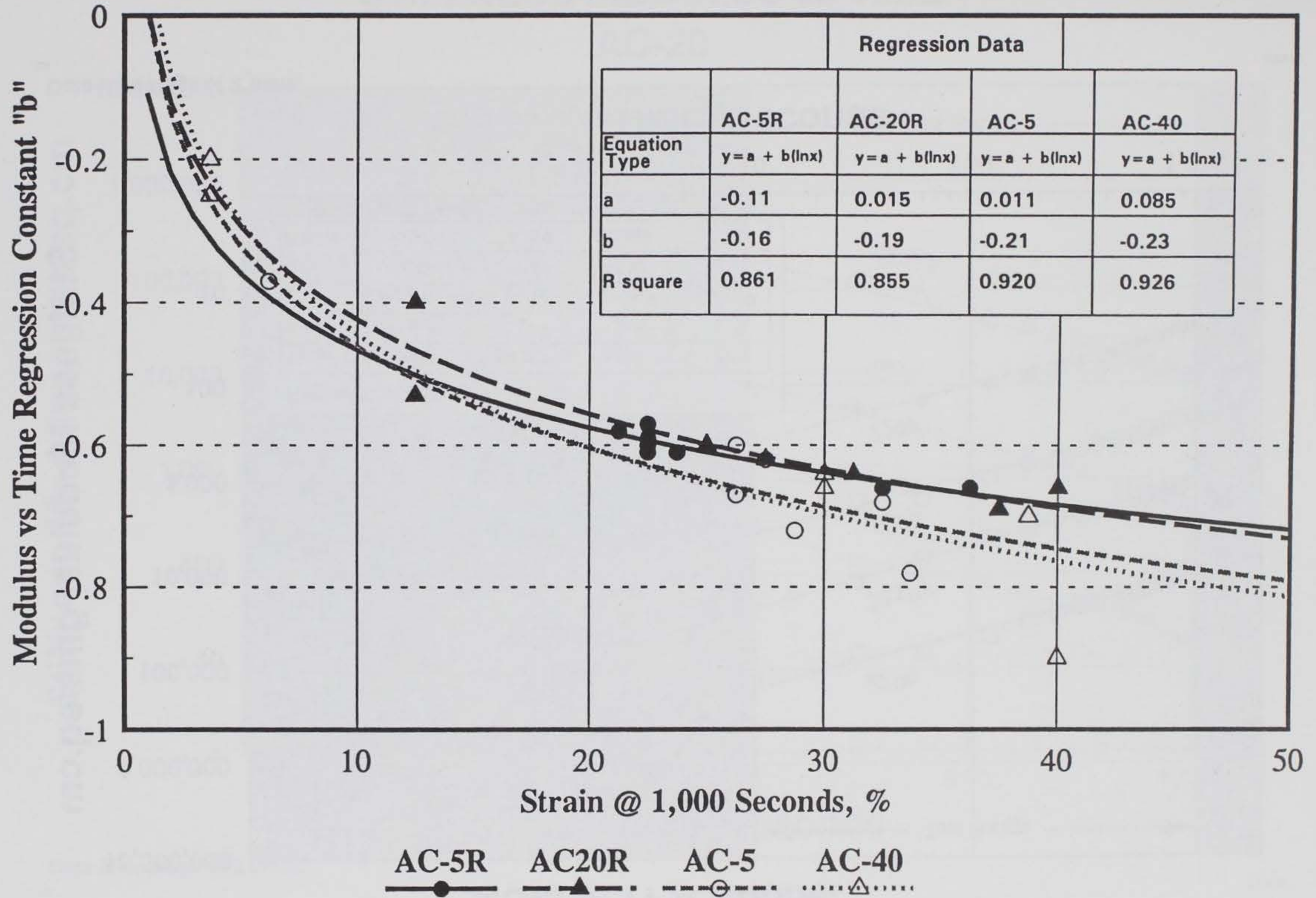

AC-5RE data not shown because of poor R-square fit.
 AC-20 data not shown because limited strain range resulted in poor R-square.

FIGURE B-23

STIFFNESS MODULUS vs TIME

AC-5 + 17% Rubber

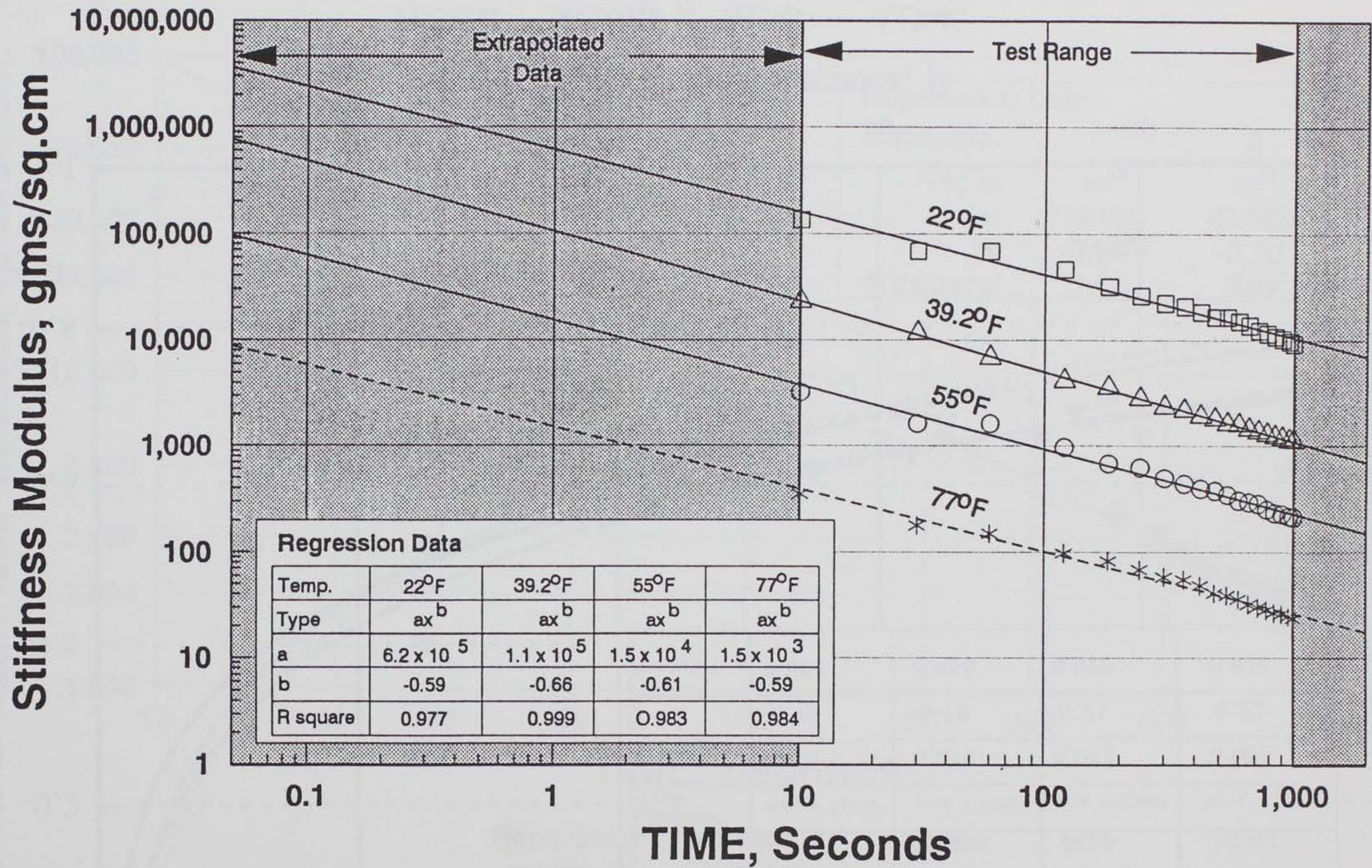

Data is average of 2 tests.

ISI

8/28/91

FIGURE C-2

STIFFNESS MODULUS vs TIME

AC-20

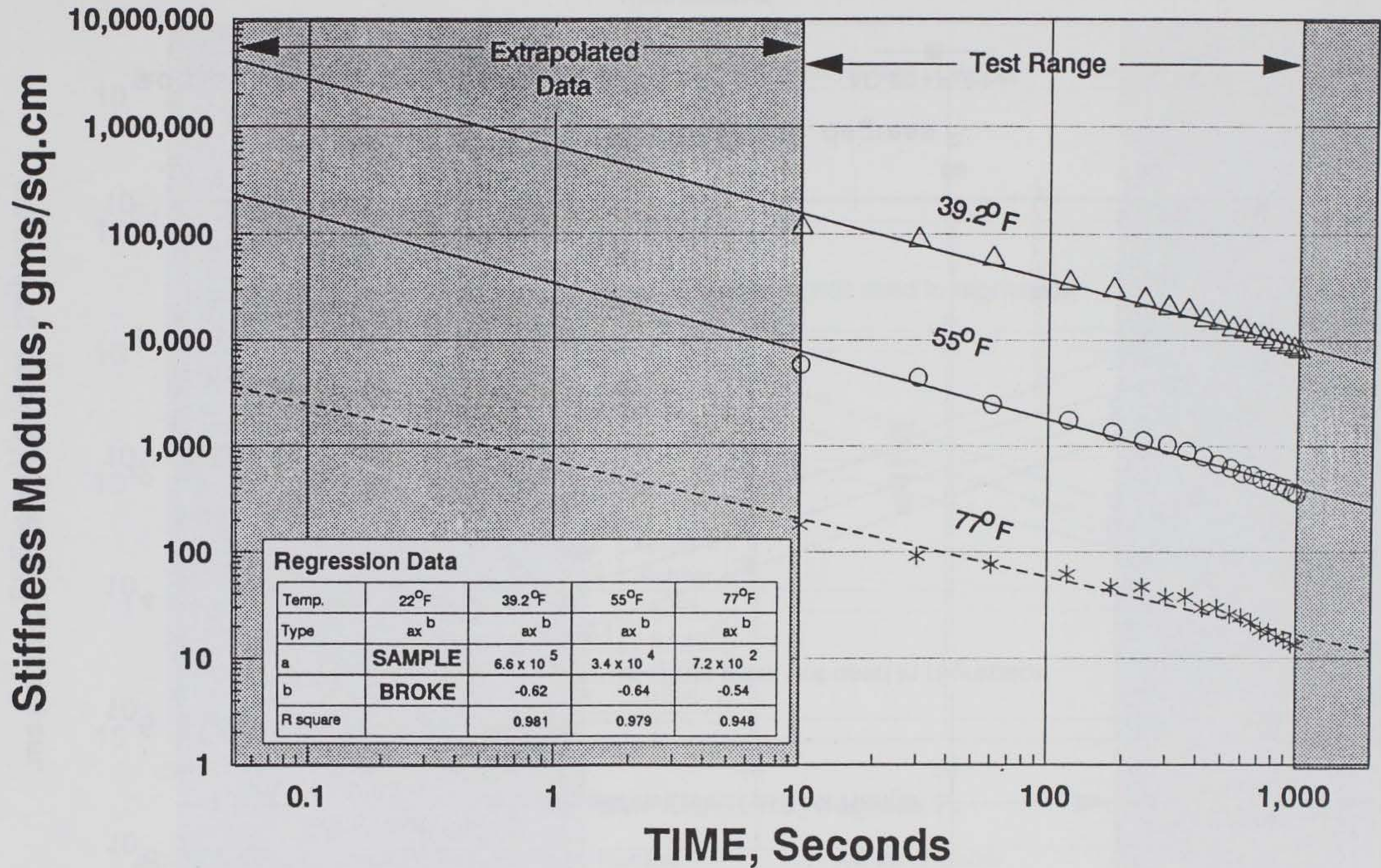

Data is average of 2 tests.

ISI

8/29/91

FIGURE C-5

STIFFNESS MODULUS vs TEMPERATURE

AC-5 & ALL ASPHALT-RUBBER BLENDS

1,000 Seconds

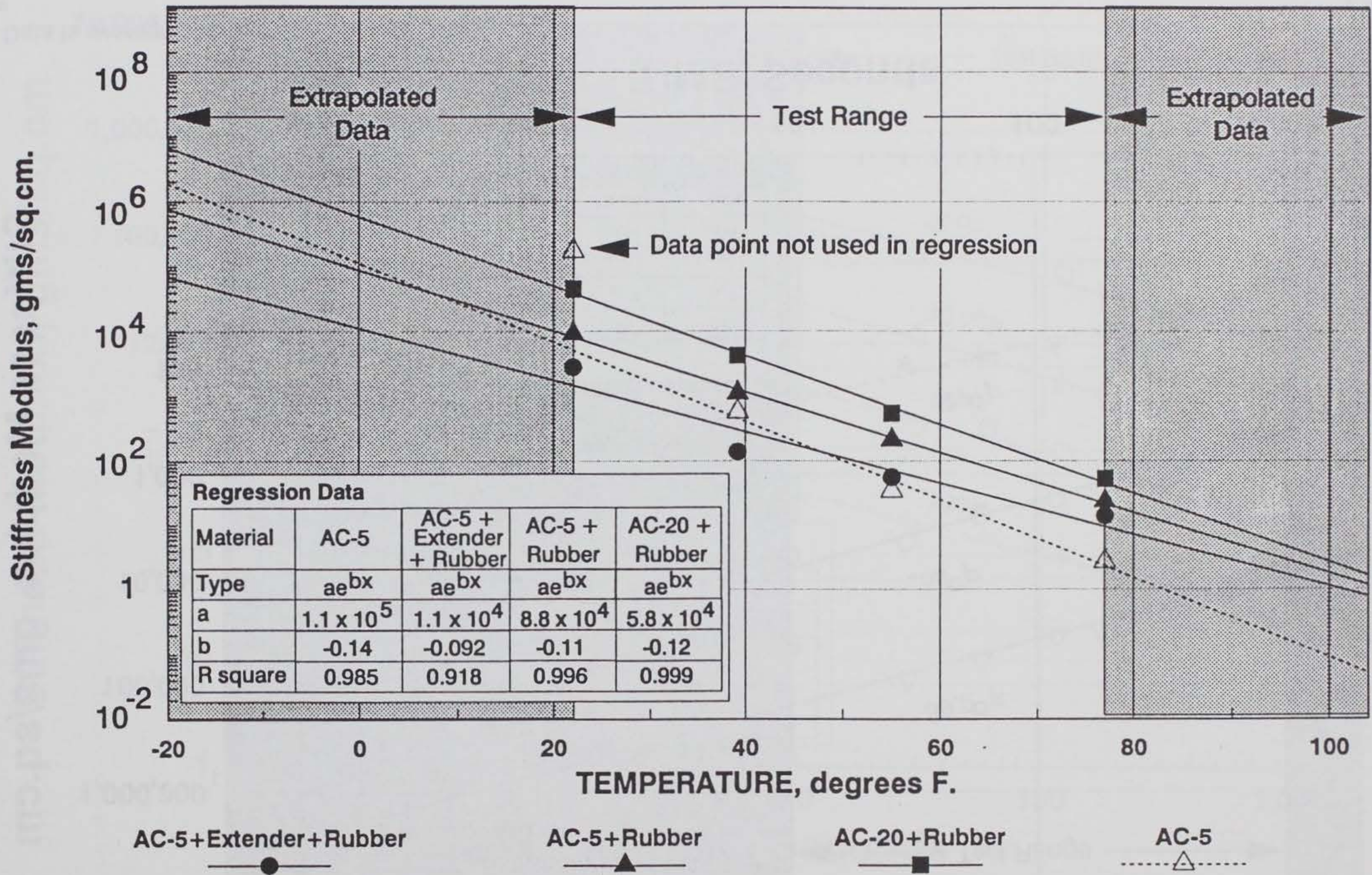
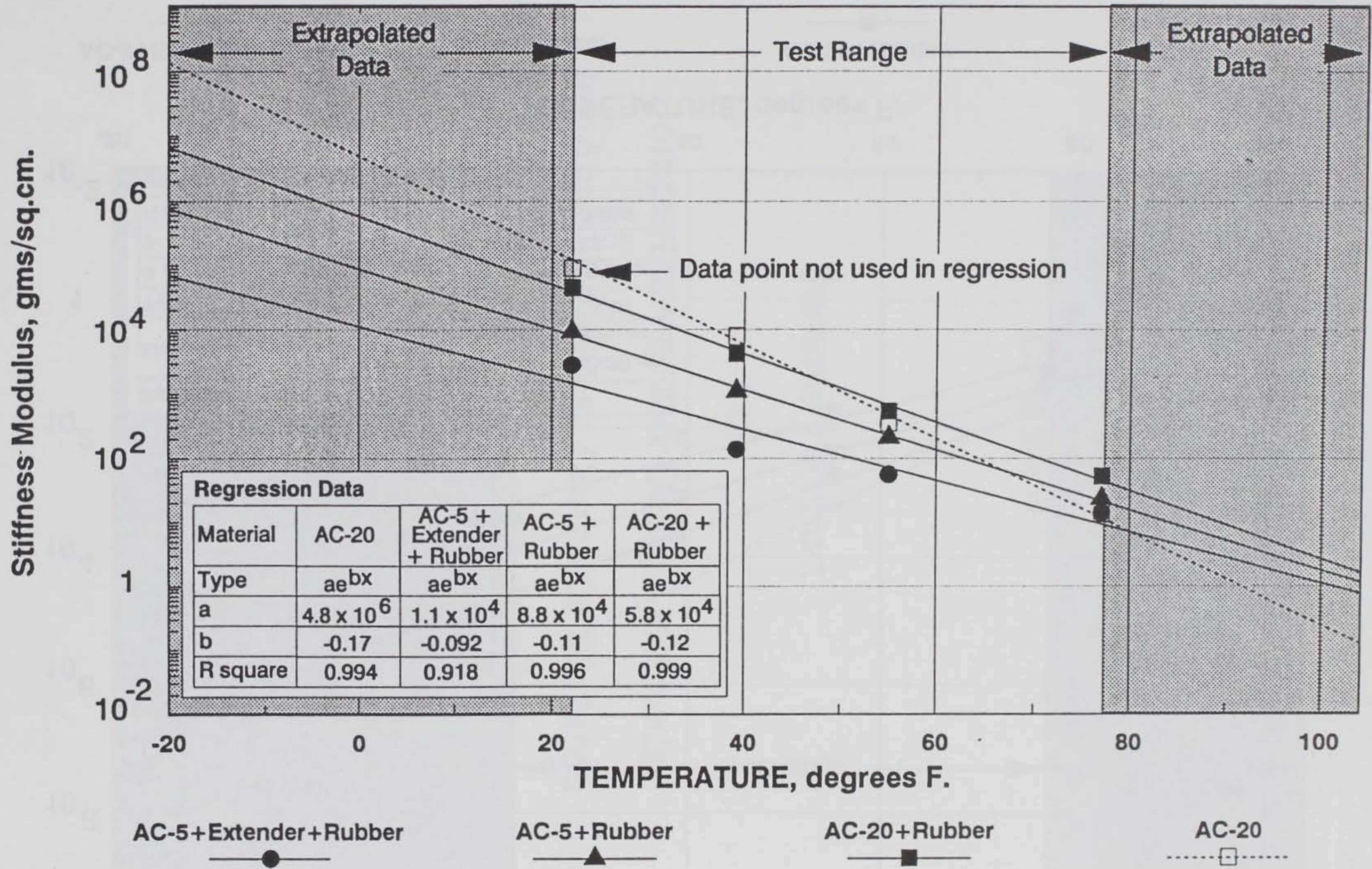

FIGURE D-3

STIFFNESS MODULUS vs TEMPERATURE

AC-20 & ALL ASPHALT-RUBBER BLENDS

1,000 Seconds



45

52

9/3/91

FIGURE D-4

STIFFNESS MODULUS vs TEMPERATURE

AC-40 & ALL ASPHALT-RUBBER BLENDS

1,000 Seconds

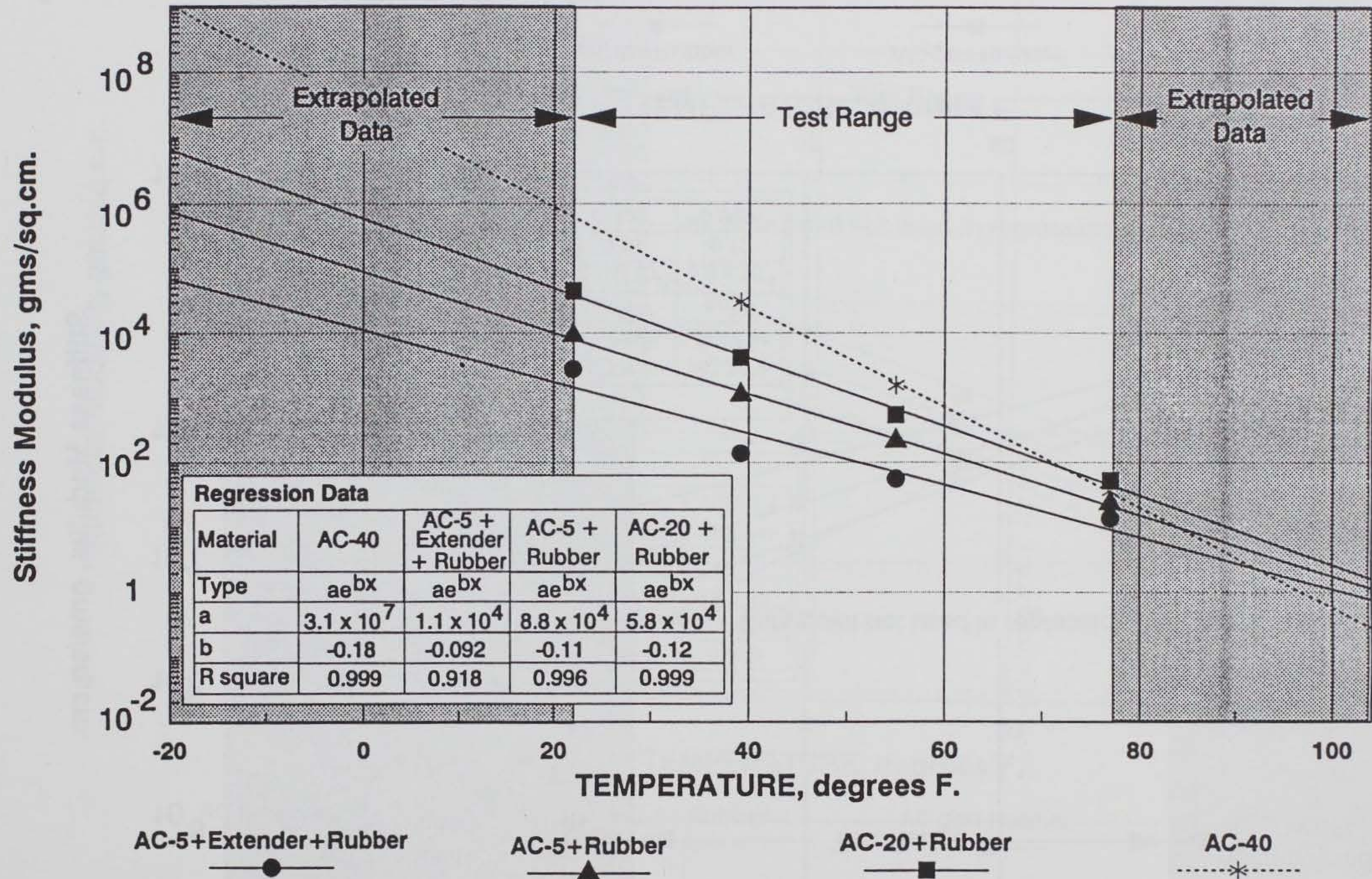

FIGURE D-5

Chapter 4

Summary Report of

Comparison of Mix Design Methods for Asphalt-Rubber Concrete Mixtures

by

Mary Stroup-Gardiner, Research Faculty
Neil Krutz, Research Associate
Jon Epps, Ph.D., P.E. Dean
Civil Engineer Department
University of Nevada, Reno

INTRODUCTION

Over the past few decades, the optimum asphalt content of asphalt concrete paving mixtures has been selected from either the Marshall or Hveem procedure. Each procedure uses a series of laboratory tests to select the optimum asphalt content. This selection is based upon satisfying the following objectives:

1. Limiting permeability.
2. Providing room for additional traffic densification.
3. Insuring adequate strength for carrying traffic loads.
4. Resisting excessive permanent deformation.
5. Providing an adequate film thickness.

Test limits were selected subjectively for these objectives based upon the experience of engineers and historical observations of pavement performance prior to the 1960's. This experience and collection of historical observations reflect the performance of typical (i.e. unmodified) mixtures at lower tire pressures, and lighter truck payloads. When this basis for the design limits is considered, two important questions need to be asked:

1. "Can these conventional methods be used with modified mixtures to select the optimum asphalt content?"
2. "Do the limits established for these mix design methods apply to modified mixtures?"

BACKGROUND

Previous research pertaining to mix designs for asphalt-rubber concrete have indicated potential changes in compaction temperature, flow limits (Marshall mix design), and air voids criteria are necessary. Suggested compaction temperatures reported in the literature are 275-300°F (Crafco, Texas A&M), 325-350°F (Vallerga), 375°F (Shuler). (1,2,3,4) Crafco, Inc. suggests increasing the flow limits to 24 for light traffic, 22 for medium traffic, and 20 for heavy traffic. (1) Mr. Vallerga suggests increasing the flow limit to 20. (3)

Criteria for acceptable air voids differs substantially. Crafco, Inc. suggests that the limits be tightened to 3 to 4 percent. (1) If these limits are not met, then adjustments for aggregate gradation or rubber size are recommended. A recent research program conducted by Texas A and M University reported using air voids of 7 percent as acceptable criteria. (2)

All of the information obtained from the literature was based upon the Marshall mix design. Conversations with personnel from Nevada Department of Transportation, and California Department of Transportation indicated that compaction temperatures for the Hveem method were elevated to around 300°F from the standard 230°F. However, Crafco, Inc. reported limited Hveem stability testing done with samples compacted at 230°F yielded satisfactory results.

RESEARCH PROGRAM

Purpose

The extended research program will include four phases of work and will evaluate:

Phase 1: The use of conventional mix design methods for determining the optimum asphalt content for asphalt-rubber mixtures.

Phase 2: Permanent deformation characteristics between asphalt-rubber and unmodified mixtures.

Phase 3: Fatigue characteristics for asphalt-rubber and unmodified mixtures.

Phase 4: Low temperature cracking resistance of asphalt-rubber mixtures.

This paper will present the outcome of the Phase 1 research. The incorporation of fundamental material properties (i.e. resilient modulus and tensile strength) will be added to the mix design procedures when possible. These tests were included in the anticipation of their providing help in recommending adjustments for current mix design parameters.

Scope

Mixture variables included in the Phase 1 research program were:

1. One aggregate.
2. An AC-5 and AC-20.
3. Asphalt-rubber AC-5 and AC-20 (16 and 17 percent by weight of asphalt cement, respectively).

The crushed granite aggregate and the AC-20 were selected from the list of materials in the Strategic Highway Research Program (SHRP) materials reference library. This selection will provide a future link between the data bases generated during this research program and the SHRP data base.

MATERIAL

Binders

Both the AC-5 and the AC-20 asphalt cement were obtained from Witco's Oildale, California refinery. The source of crumb rubber was selected by the sponsor and the asphalt-rubber was mixed by CrafcO, Inc. at their Phoenix, Arizona laboratory.

The physical properties of the unmodified asphalt cement is presented in Table 1. The appropriate American Society for Testing and Materials (ASTM) specifications are also included in this table for comparison.(5) The physical properties of the asphalt-rubber cements are presented in Tables 2 and 3.

Rubber

The rubber used in this research program was an ambient ground rubber with a rubber hydrocarbon content of approximately 45 percent, and a specific gravity between 1.100 and 1.200. The particle size, along with a gradation specification suggested by CrafcO, are shown in Table 4.

Aggregate

The aggregate was obtained from Granite Rock Co., in Watsonville, California. This material is a 100 percent crushed aggregate with no history of stripping (i.e. debonding of asphalt from aggregate) problems. The physical properties are presented in Table 5.

The gradation used to prepare the laboratory samples is shown in Table C and Figure 1. This gradation was chosen to meet ASTM D3315 1/2-inch dense mixture, Nevada Type 2, and California 1/2-inch medium specifications (also shown in Table 6).

The combined gradation of both the aggregate and the rubber particles are also shown in Figure 1.

SAMPLE PREPARATION AND TESTING SEQUENCE

Marshall Mix Design

Sample preparation and testing was completed according to ASTM D1559.(5) Two exceptions were made in the ASTM D1559 procedure. First, the material was placed in a 275°F oven for 1-hour after mixing and before compacting to insure that the mixture was at the appropriate compaction temperature. Secondly, the compacted modified samples were allowed to remain in the molds overnight,

placed in 230°F for 5 minutes, then extruded. This delay in extrusion was to ensure that there was no volumetric increase in sample size due to the rebound properties of the rubber.

The testing sequence was:

1. Mixing, compaction (50 blows per side, by hand), and extrusion of samples.
2. Cooled to 77°F and heights, resilient modulus (ASTM D4125) and bulk specific gravity (ASTM D2726) determined.
3. Samples were then placed in a 140°F water bath for a half hour. Marshall stability and flow were determined (ASTM D1559).
4. Theoretical maximum specific gravity (ASTM D2041) was determined on extra material retained during mixing.

The resulting data was evaluated according to the criteria for stability, flow, unit weight, air voids, and VMA described in the Asphalt Institute's Manual Series No. 2.

The resilient modulus was determined with a Retsina Mark IV device that dynamically loads a diametrically positioned sample for 0.1 seconds every 3 seconds.

Hveem Mix Design

ASTM D1560 and D1561: Samples were originally prepared in accordance with ASTM D1561 and tested according to ASTM D1560.(5) The only exception to either test method was that the samples were extruded after the leveling load and cooled to 77°F for resilient modulus testing. The following sequence for sample preparation and testing was used:

1. Mixing, compaction (20 blow at 250 psi, 150 at 500 psi), leveling load (12,600 pounds) and extrusion of samples.
2. Samples were then cooled to 77°F and the sample height, resilient modulus (ASTM D4125) and bulk specific gravity (ASTM D2726) determined.
3. Samples were placed in a 140°F oven for 2 hours, then the Hveem stability was determined.
4. Samples were cooled to 77°F, then the tensile strength was determined.
5. Theoretical maximum specific gravity was then determined.

Evaluation of test results from this procedure yielded unacceptable test results. Based upon this information, a decision to increase the compaction temperature from the traditional 230°F to 300°F was made. This temperature is consistent with previous field compaction temperatures reported by Crafc0, Inc.

Samples were extruded immediately after the leveling load was applied; samples were not cooled down prior to extrusion.

Modification to Compaction Procedure: Samples were mixed, and placed in a 300°F oven for three hours. Samples were then compacted, extruded, and tested as outlined above.

ANALYSIS OF TEST RESULTS

The analysis will be presented in five sections:

1. Marshall mix design.
2. Hveem mix design.
3. Comparison between mix design methods.
4. Testing concerns.
5. Additional testing (i.e. resilient modulus and tensile strength).

Table 7 presents the design criteria as presented in the Asphalt Institutes Manual Series No. 2, 1984 for both the Marshall and Hveem mix designs for medium traffic conditions. (6)

Marshall Mix Design

Table 8 and Figures 2 and 3 present the test results for both the unmodified and modified mixtures. It can be seen that the addition of rubber tends to reduce the stability and unit weight, while increasing the voids in mineral aggregate (VMA) and flow. Similar levels of air voids can be obtained. These trends are consistent with other research findings and are expected.

It is interesting to note that a mixture with originally unacceptable VMA (Figure 2) can be remedied by the addition of rubber. This is most likely a result of greater film thickness due to the increased viscosity and less absorption of the binder by the aggregate.

The increased flow values while greater than the mix design limits, should be expected. Asphalt-rubber materials should be expected to exhibit greater ability to deform prior to failure.

Based on these limited test results, it appears that only the flow criteria for the Marshall mix design needs to be increased with asphalt-rubber materials. Asphalt-rubber mixtures can be formulated to meet all of the other design criteria.

Hveem Mix Design

Tables 9 and 10, and Figures 4 through 7 present the test results for this testing. Mix design samples were originally prepared according to the conventional mix design procedure prescribing a 230°F compaction temperature. This data is presented

in Table 9 and it can be seen that the majority of the test results are unacceptable.

A second set of mix design samples was prepared using a compaction temperature of 300°F. The results of this testing are shown in Table 10. A comparison of test results for the different compaction temperatures is shown in Figures 4 and 5. In general, the higher compaction temperature can reduce stability and air void values. The impact of compaction temperature on VMA and unit weight varies between AC 5 and AC 20 modified mixtures.

Based upon this comparison, the 300°F compaction temperature for modified mixtures was chosen for the selecting the optimum asphalt content and any further comparisons of data.

Modified mixtures tend to exhibit a reduction in stability, similar to the trend observed in the Marshall mix design. However, the impact of rubber on the unit weight, VMA, and air voids varies with the base asphalt. While the trends varied between base binders, acceptable ranges of air voids were obtained with both modified mixtures. Neither modified mixture met the Hveem stability limits.

This failure of modified mixtures to meet the traditional Hveem stability limits while being able to meet Marshall stability requirements should be expected and can be explained by the differences in the tests. Marshall stability is a measure of ultimate material strength while Hveem stability is a measure of the material's ability to deform laterally for a given vertical load. Given the deformable nature of rubber, it should be expected that asphalt-rubber mixtures will deform more for a given load, thereby reducing the Hveem stability values. On this basis, it is suggested that lower Hveem stability limits than those traditionally used could still produce acceptable mixtures.

Comparison Between Marshall and Hveem Mix Designs

Figure 8 shows a comparison of the optimum asphalt contents selected for each mix design. It can be seen that adding rubber to the mixtures increases the optimum asphalt content, regardless of mix design method. In general, there appears to be a variation of ± 0.5 percent optimum asphalt content between the mix design methods, regardless of type or modification of binder.

Testing Concerns

One of the concerns expressed during this research program was the potential volumetric expansion of the sample after extrusion due to the ability of the rubber to rebound. A limited investigation of this phenomena was investigated.

Both one-dimensional expansion of the sample in the mold and three-dimension expansion of extruded samples was examined. A soil consolidation gauge was used to measure the expansion of a sample in a mold both immediately after compaction and after storage at 77°F for 24 hours. The average expansion of the modified AC 5 was 30/10,000 of an inch. It is felt that this was an insignificant volume change.

Hveem compacted modified AC 5 samples were extruded immediately after the leveling load was applied. Table 11 shows the results for two of these samples. Heights were measured four times around the sample and the diameter was measured twice for each of the top and bottom. Again, it can be seen that the volume change appears to be insignificant.

Fundamental Material Properties

Figures 9 and 10 present the results of both the resilient modulus and tensile strength testing for samples compacted at the optimum asphalt cement content. Figure 9 shows that modified mixtures significantly decrease material stiffness at the colder temperatures. The material stiffness is either unaffected or significantly increased at the warmer temperatures.

These trends indicate that modified mixtures can be beneficial in reducing thermal cracking by reducing material stiffness at cold temperatures. It also indicates that rutting (i.e. permanent deformation) can be decreased by increasing material stiffness at the warmer temperatures. Further research in the areas of fatigue testing and permanent deformation will be necessary to ascertain the magnitude of the benefits obtained from these rubberized materials.

Figure 10 shows the tensile strengths of both unmodified and modified mixtures. It can be seen that the addition of rubber results in a slight decrease in tensile strengths.

CONCLUSIONS

This research program supports the following conclusions:

1. Marshall mix design. Asphalt-rubber mixtures can be expected to exhibit lower stability and unit weights, and higher VMA and flow than unmodified mixtures; four percent air voids can be obtained with asphalt-rubber mixtures. It is recommended that the flow limits be increased; previous suggestions of 22 to 24 for flow appear to be reasonable.

2. Hveem mix design. An increase in compaction temperature from 230 to 300°F produces mixtures that can meet the majority of the traditional Hveem mix design criteria. The Hveem stability limits should be lowered because of the increased lateral deformation per given load that is obtained with the presence of rubber.
3. Comparison of mix design methods. Rubber appears to increase the optimum asphalt cement content, regardless of mix design method. Variations of + 0.5 percent asphalt were noticed between the two methods, regardless of binders or modifiers.
4. Testing concerns. It appears that the volumetric increase in the sample size is insignificant when the samples are extruded immediately after compaction. However, this conclusion is based on limited results and should be explored more extensively.
5. Fundamental material properties. A significant reduction in material stiffness at cold temperatures is obtained when rubber is added to the mixture. Material stiffness can possibly be increased at warmer temperatures with the addition of rubber. The addition of rubber tends to result in a slight reduction in tensile strengths.

ACKNOWLEDGEMENTS

This research was possible due to the continuing commitment of the Asphalt Rubber Producers Group to the development and expanding implementation of asphalt-rubber concrete mixtures. The authors would also like to thank Jim Chehovits, and the laboratory staff of CrafcO, Inc. for their support, ideas, and experience in this area.

BIBLIOGRAPHY

1. Chehovits, J.G., "Design Methods for Hot-Mixed Asphalt-Rubber Concrete Paving Materials, CrafcO, Inc. (No date)
2. Hoyt, D.M., Lytton, R.L., Roberts, F.L., "Criteria for Asphalt-Rubber Concrete in Civil Airport Pavements," FAA Report No. DOT/FAA/PM-86/39, II.
3. Vallerga, B.A., "Design and Specification of Changes for Paving Mixtures with Asphalt-Rubber Binders," Proceedings, National Seminar on Asphalt-Rubber, San Antonio, Texas, October, 1981.
4. Shuler, S., et.al., "Investigation of Material and Structural Properties of Asphalt-Rubber paving Mixtures," FHWA Report No. FHWA/RD-86/027, September, 1986.
5. Annual Book of ASTM Standards, 1987
6. Mix Design Methods for Asphalt Concrete, The Asphalt Institute's Manual Series No.2, 1984

Table 1 : Physical Properties of Rubber Used in Preparing Modified Binders

Test	Baker IGR-24	Manufacturer Recommendations
Particle Size		
#10	100	100
#16	99.8	100
#30	78.0	70 - 100
#40	48.8	----
#50	26.6	----
#80	9.2	0 - 20
#100	6.6	----
#200	0.2	0 - 5

Table 2: Comparison Between Laboratory Gradation Used to Prepare Samples and Several Specification Limits

Sieve Sizes	Lab. Grad.	ASTM D3315 1/2" Dense	Nevada Type 2	California 1/2" Med.
Cumulative Percent Passing, %				
3/4"	100	100	90-100	100
1/2"	98	90-100	---	89-100
3/8"	85	---	63-85	75-100
#4	58	44-74	45-63	51-74
#8	40	28-58	---	35-57
#10	--	---	30-44	---
#16	28	---	---	---
#30	20	---	---	14-35
#40	--	---	16-24	---
#50	14	5-21	---	---
#100	9	---	---	---
#200	5	2-10	3-9	0-11

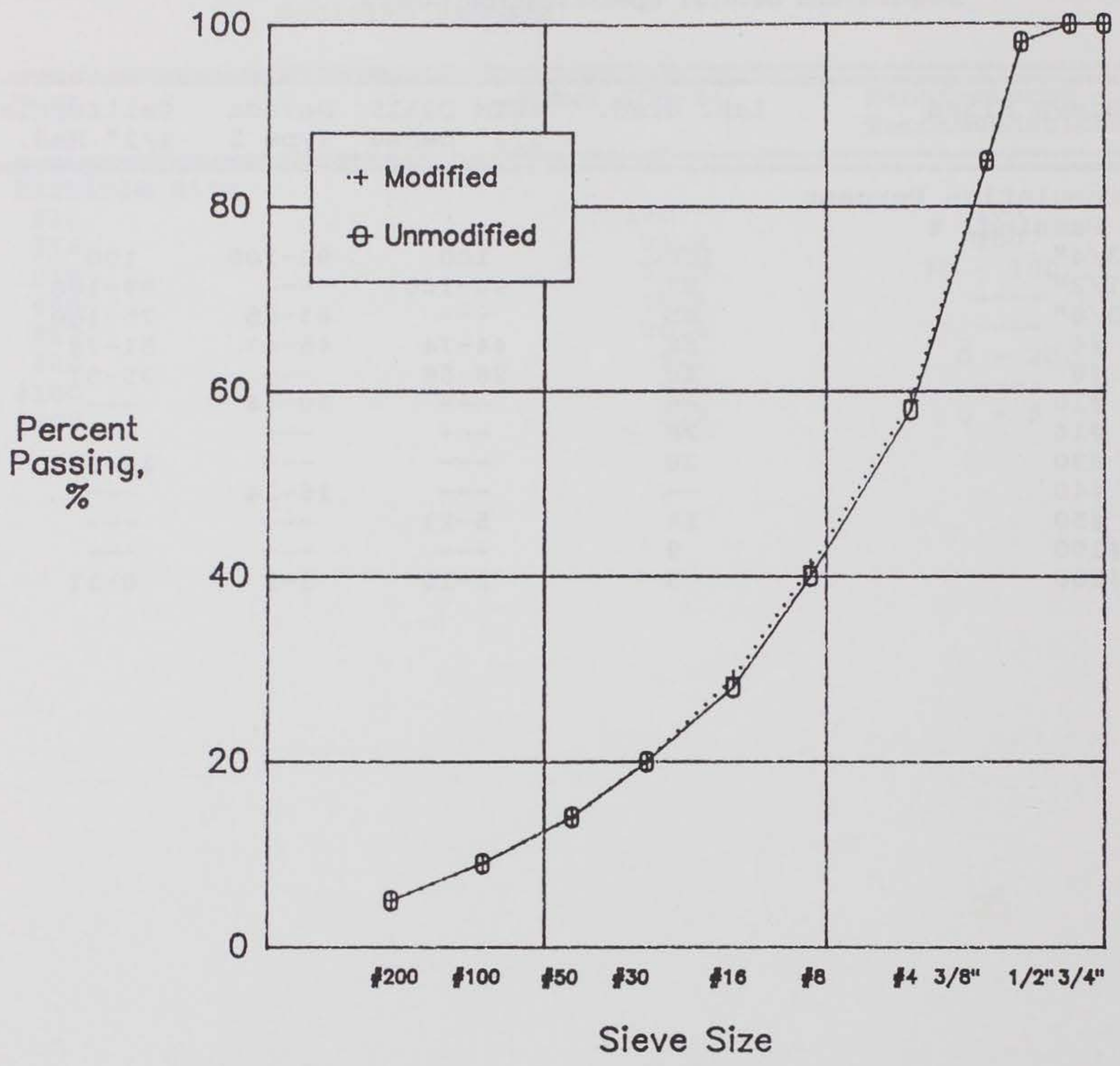
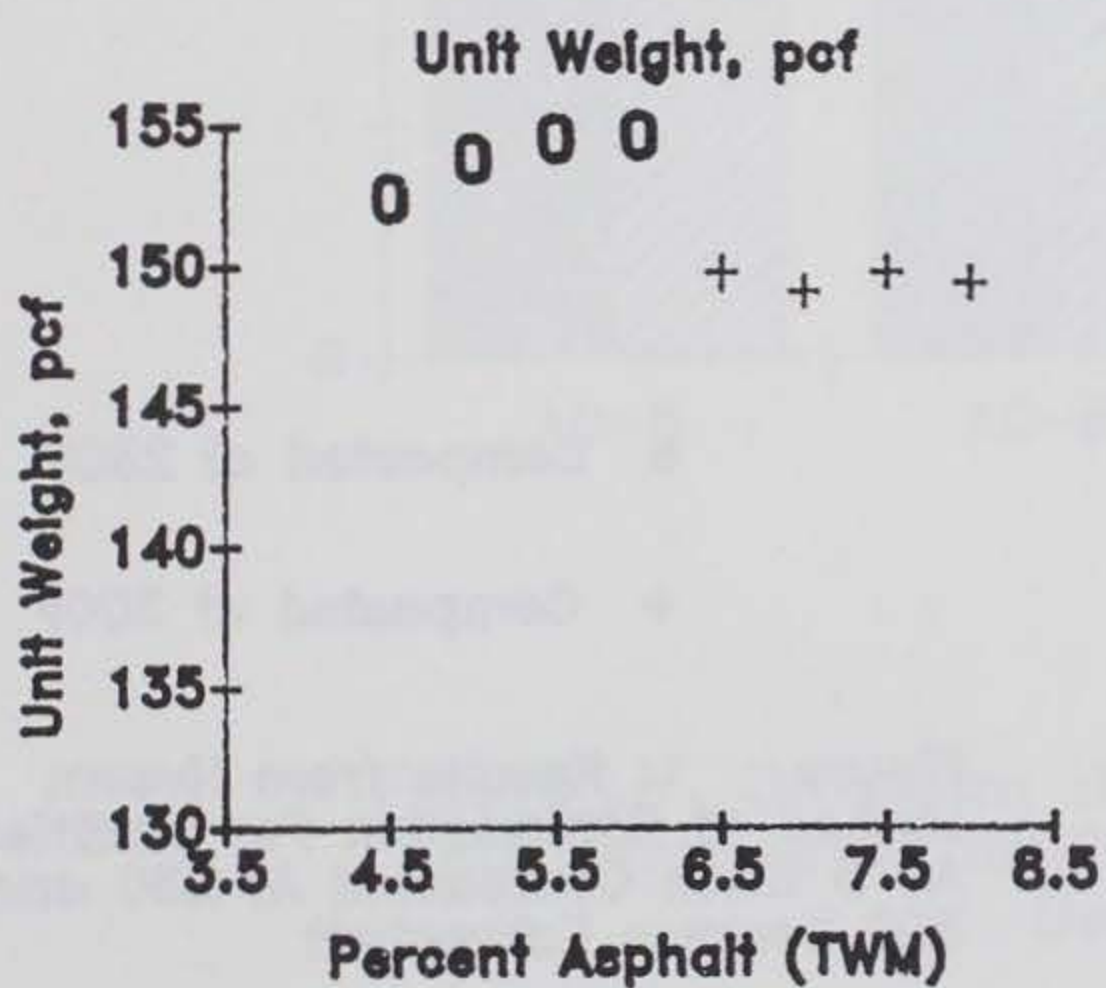
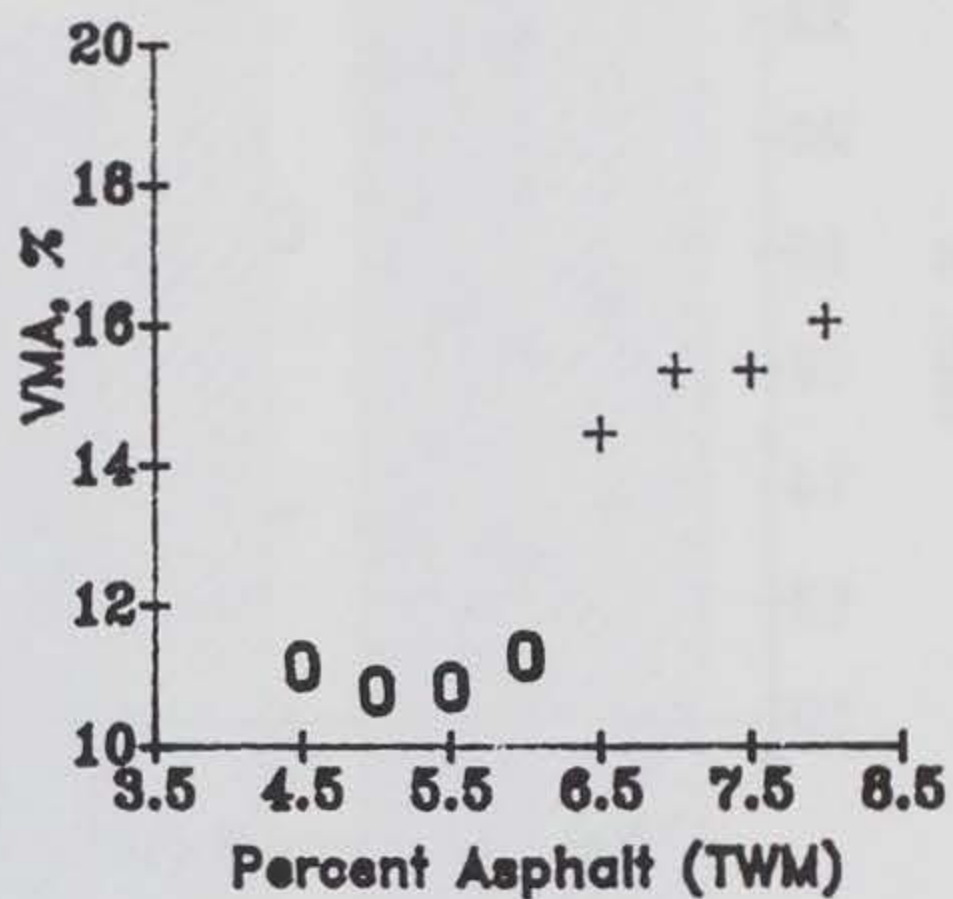
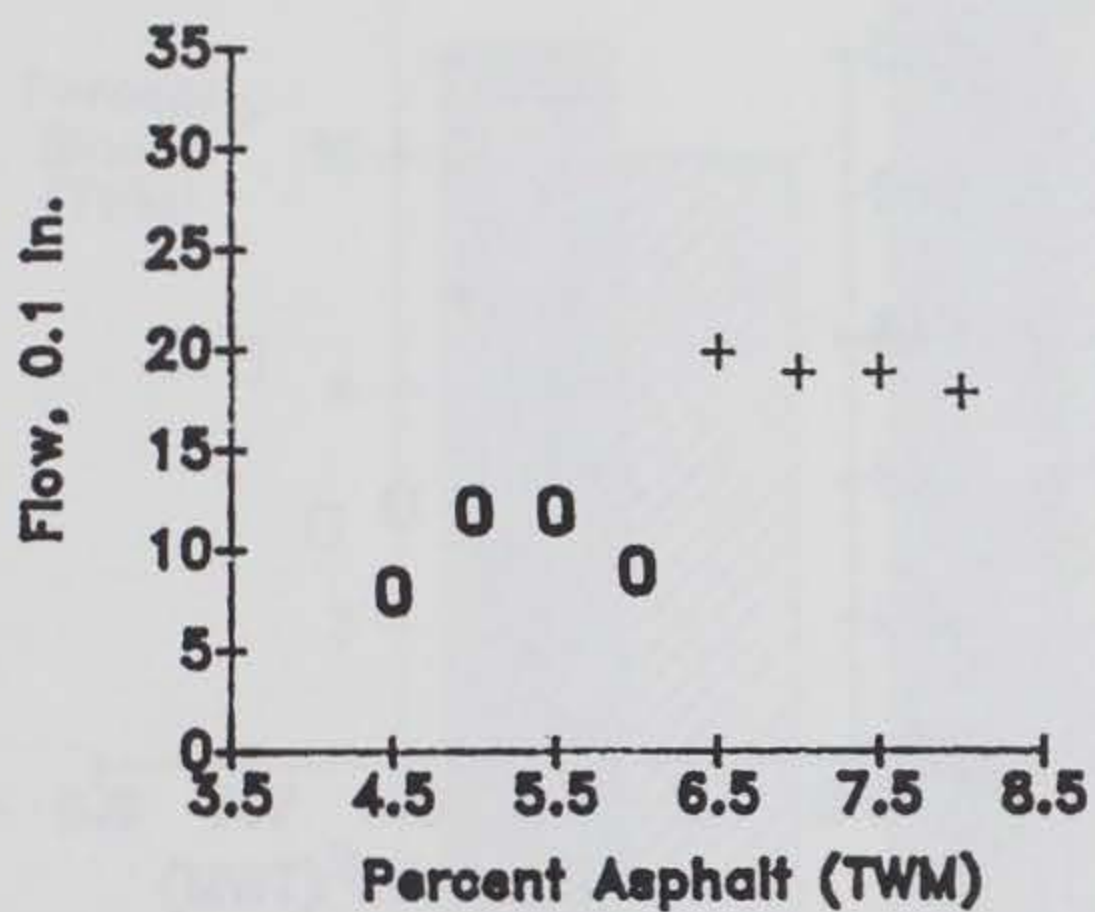
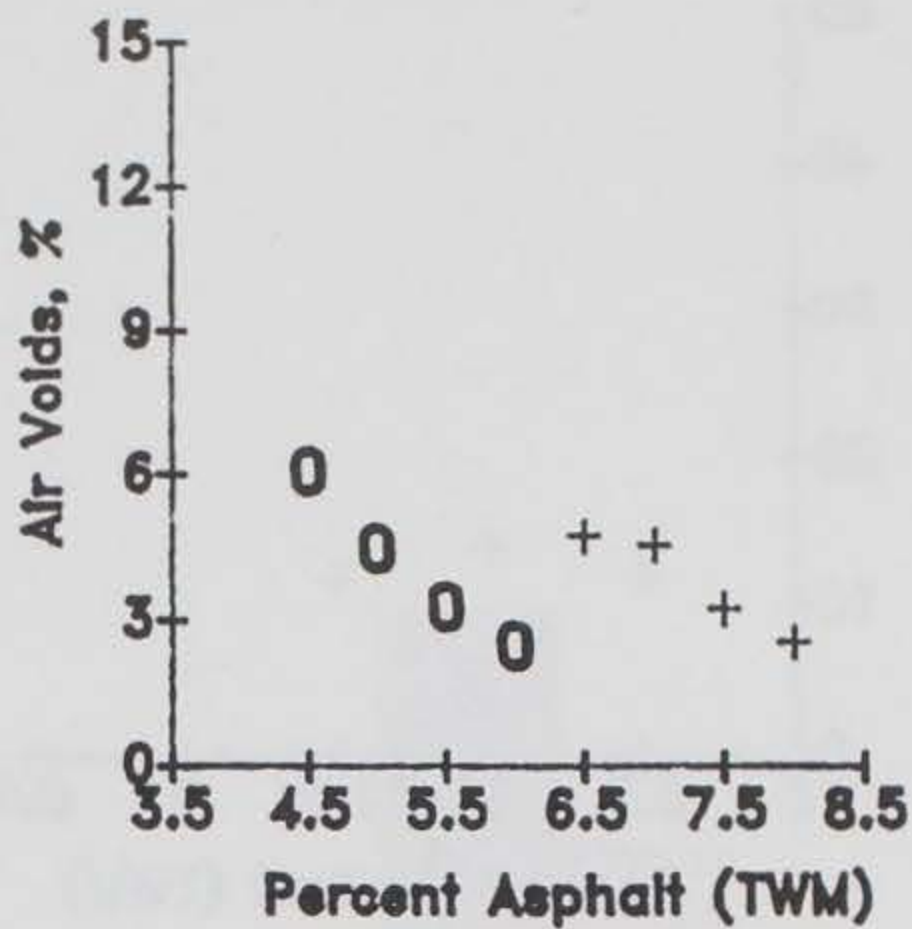
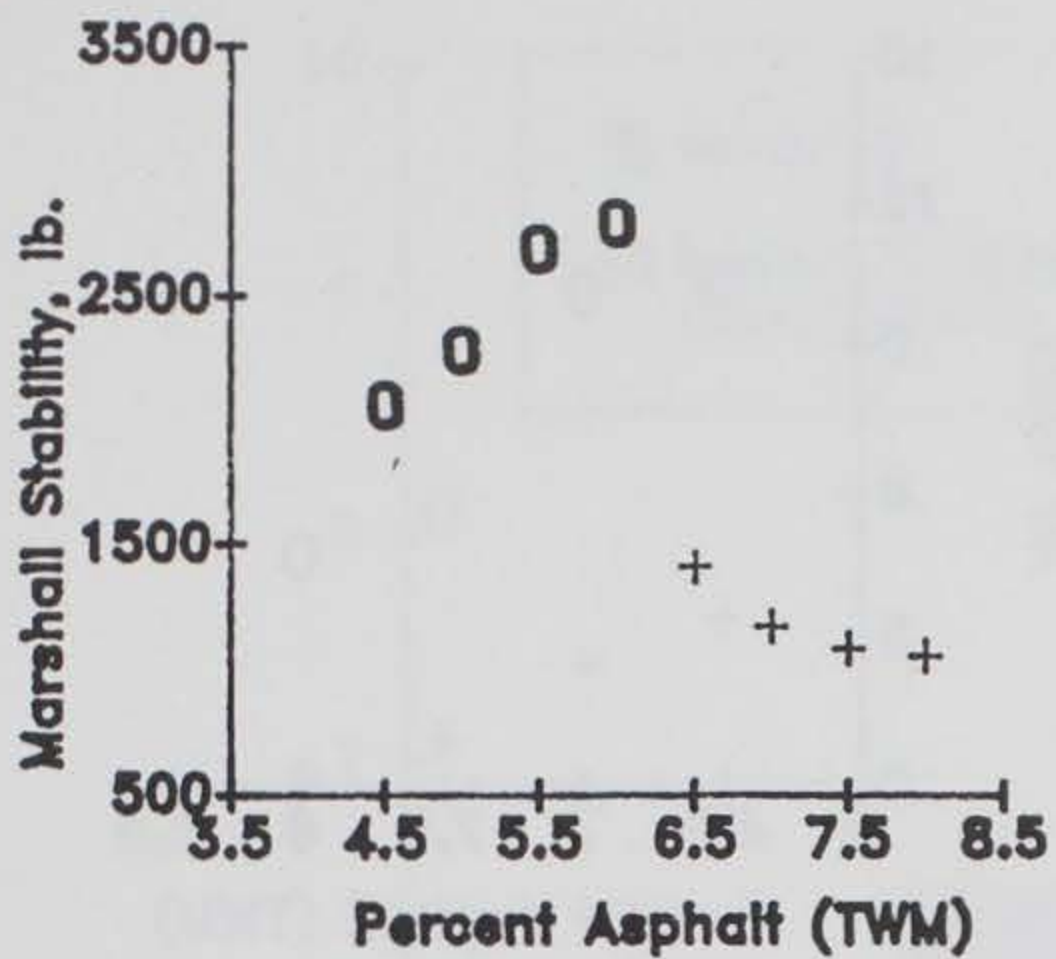
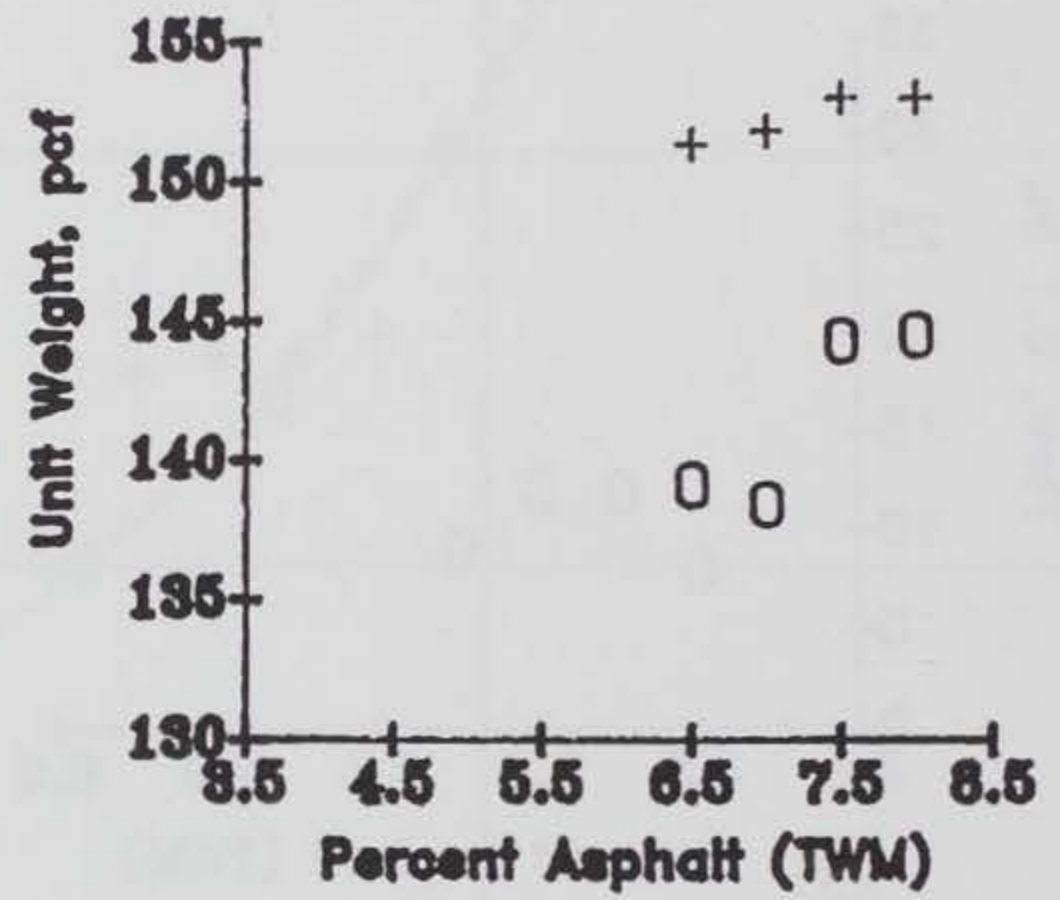
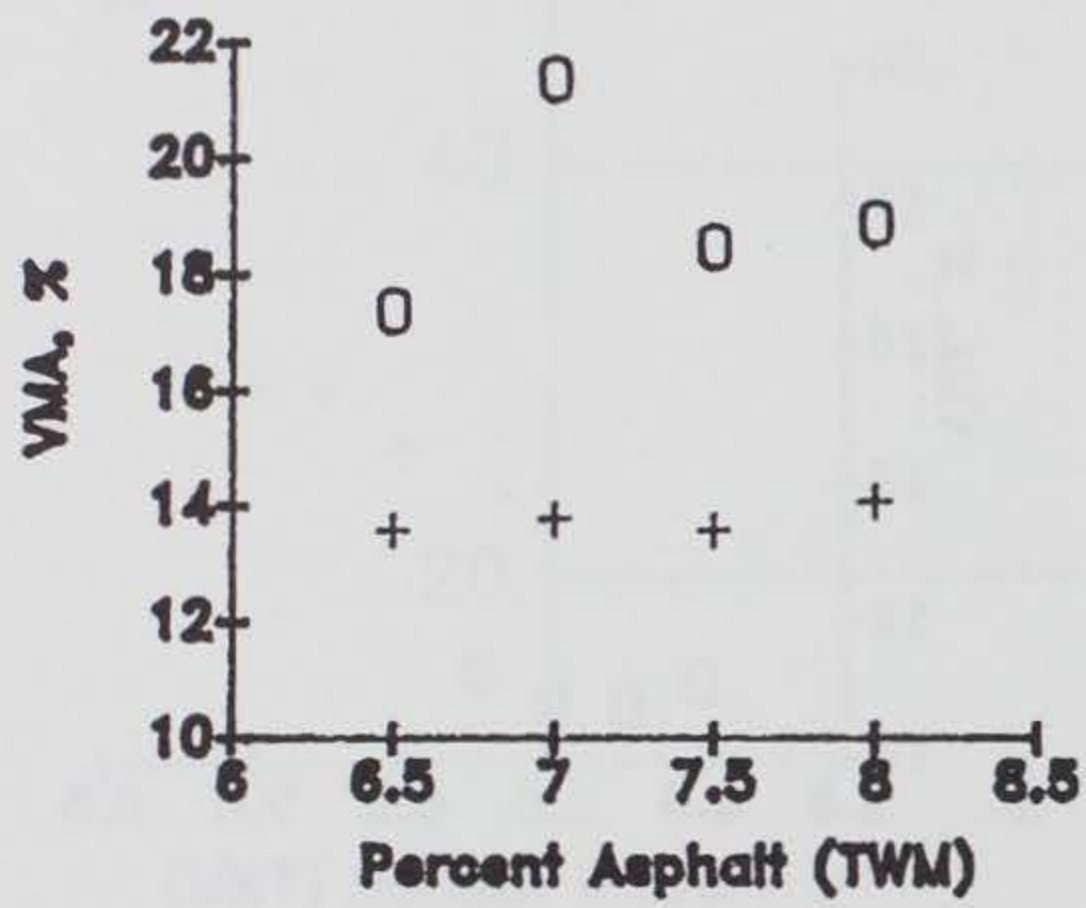
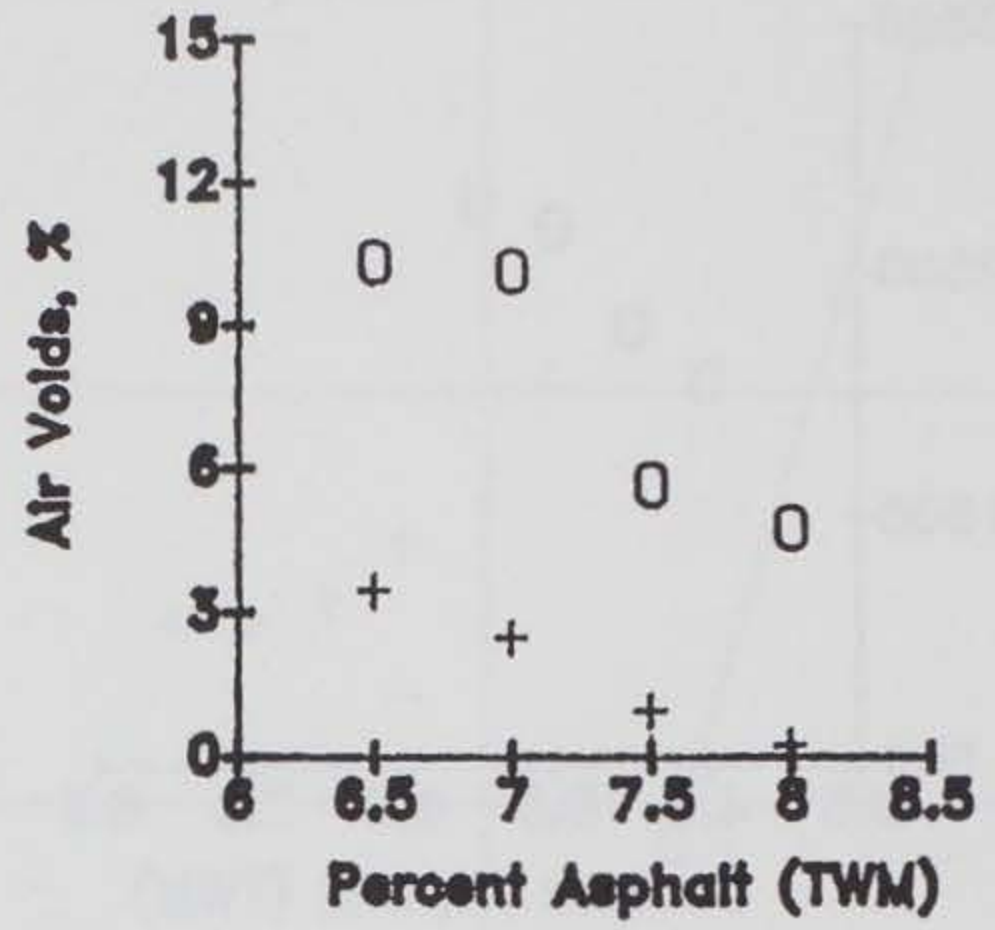
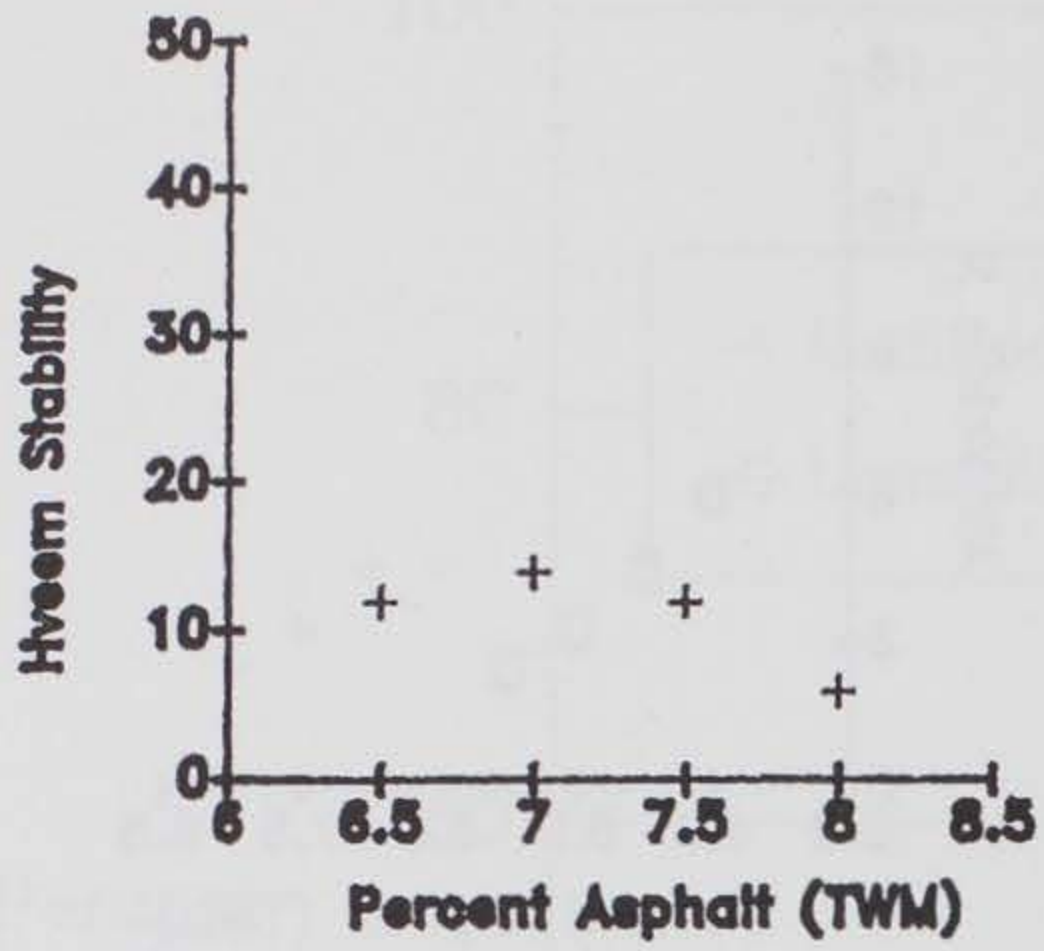

Figure 1 : Gradations Used for Mixtures Including Rubber As An Aggregate in the Modified Gradation.



o Unmodified AC-5
 + Modified AC-5
 (16% Rubber)

Figure 2 : Results from Marshall Mix Design for Modified and Unmodified AC-5



o Compacted at 230F

+ Compacted at 300F

Figure 3: Results from Hveem Method of Compaction For Modified AC 5 When Compacted At 230 and 300 Degree Fahrenheit

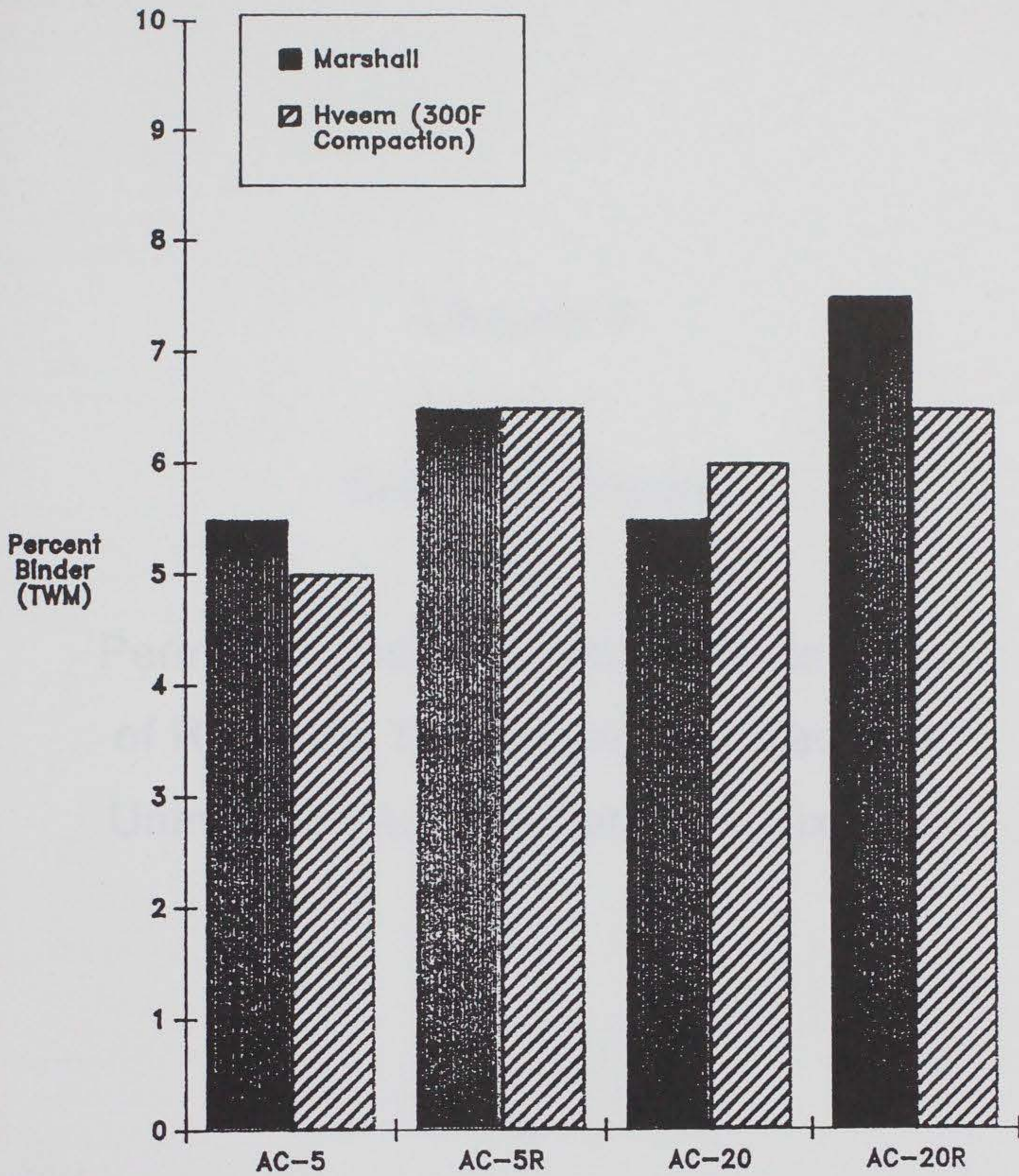

Figure 4: Optimum Binder Contents For Both Modified And Unmodified Binders For Marshall And Hveem Mix Design Methods.



Figure 1. Comparison of Design Features for both Standard and Customized Systems for Hospital and Home Use. The Y-axis represents the number of design features. The X-axis represents the design features for both Standard and Customized Systems.

Chapter 5

Summary Report of

Permanent Deformation Characteristics of Recycled Tire Rubber Modified and Unmodified Asphalt Concrete Mixtures

by

Neil C. Krutz, Research Associate
Mary Stroup-Gardiner, Research Faculty
University of Nevada, Reno

ABSTRACT

In recent years, modified asphalt mixtures have become increasingly popular in the construction of flexible pavements. These products have gained popularity because of their ability to increase resistance to rutting at warm temperatures while reducing the occurrence of thermal cracking at cold temperatures. This coupled with the growing problem of waste rubber tires, has lead to the reprocessing (grounding) of tire rubber for use in asphalt concrete mixtures.

In order to investigate the warm temperature rutting hypothesis, a laboratory research program utilizing both static and repeated load permanent deformation tests, carried out at two temperatures (77°F and 104°F), was designed in order to assess the potential benefits of rubberized asphalt concrete mixtures.

Conclusions from this research indicated that the addition of ground tire rubber to asphalt concrete mixtures results in mixtures that exhibit less permanent deformation at high temperatures compared to unmodified mixtures. The research also indicated that permanent deformation testing should be carried out at high temperatures under repeated loading. The relative ranking of strain changes from 77°F to 104°F for both methods of testing and static testing indicates the presence of rubber, however, it does not indicate anything about the base asphalt. The repeated load testing indicates, in a concrete manner, the differences that exist between binders.

INTRODUCTION

In recent years, modified asphalt mixtures have become increasingly popular in the construction of flexible pavements. These products have gained popularity because of their ability to increase resistance to rutting at warm temperatures while reducing the occurrence of thermal cracking at cold temperatures. This coupled with the growing problem of waste rubber tires, has led to the reprocessing (grounding) of tire rubber for use in asphalt concrete mixtures.

In order to investigate this hypothesis, a laboratory research program was designed in order to assess the potential benefits of asphalt-rubber concrete mixtures.

RESEARCH PROGRAM

The extended research program was designed to include four phases:

Phase 1: The use of conventional mix design methods for determining the optimum asphalt content for asphalt-rubber mixtures.

Phase 2: Permanent deformation characteristics of asphalt-rubber and unmodified mixtures.

Phase 3: Low temperature cracking resistance of asphalt-rubber and unmodified mixtures.

Phase 4: Fatigue characteristics for asphalt-rubber and unmodified mixtures.

This report will deal with the laboratory results from Phase 2 only. Phase 1 has been completed and reported in "Comparison of Mix Design Methods for Asphalt-Rubber Concrete Mixtures" (1). Both Phases 3 and 4 are currently being completed.

The scope of this research program includes one aggregate source, one gradation and six binders. The test matrix is shown in **Table 1**.

MATERIALS

Aggregates

The aggregates used in this research program were obtained from Granite Rock Company, located in Watsonville California. This material is a 100 percent crushed granite that has no history of stripping problems with in-service pavements. The physical properties are presented in **Table 2**.

Type of Binder	Binder Content Used In Preparing Samples (% , Total Weight of Mix)	UNR Recommended Binder Content (% , Total Weight of Mix)
AC5R	8.5	7.7
AC5RE	8.3	7.7
AC20R	7.9	7.4

The result of this compromise is a binder rich mixture. This should be remembered when assessing any of the permanent deformation data contained in this report.

SAMPLE PREPARATION

Samples were batched by first separating the aggregates into the eleven individual sizes (1/2", 3/8", 1/4", #4, #8, #16, #30, #50, #100, #200, fines) needed to prepare samples, and then recombined to meet the desired gradation. Washed sieve analysis were performed utilizing complete batches to ensure the gradation had been met.

After all aggregate preparation was completed, batches were selected at random and mixed with the selected binder. Different methods of mixing and compaction were used for the asphalt-rubber and unmodified mixtures. The procedure for each method is described below.

Unmodified mixtures were mixed in accordance with ASTM D 1561(2). After mixing, samples were placed in a 140°F forced draft oven for fifteen hours prior to being reheated to 230°F for compaction. Eight inch in height by four inch in diameter specimens were compacted in thirds using a kneading compactor. Each lift, or third, received 30 blows at 250 psi. Lifts were compacted consecutively on top of each other. After compaction of the third lift, each sample was placed in a 140°F oven for 1 1/2 hours prior to the application of a 5,000 lb. leveling load. Samples were allowed to cool before being extruded.

Asphalt-rubber mixtures were mixed using the recommendations of Chehovits (3). This involves heating the aggregate to 300°F and the asphalt-rubber binder, regardless of base asphalt viscosity, to 350°F prior to mixing. Once again, after mixing, samples are placed in a 140°F forced draft oven for fifteen hours prior to reheating the samples for compaction. Samples using the asphalt-rubber AC-20 were reheated to 300°F for compaction while the other two asphalt-rubber mixtures, AC5R and AC5RE, were reheated to 230°F. The same compaction procedure as described above was used for the asphalt-rubber mixtures with the exception of extending the 1 1/2 hour cure time at 140°F to three hours for the AC20R. Asphalt-rubber samples were allowed to cool before being extruded.

The gradation used to prepare the mixture samples is shown in **Table 3**. This gradation was chosen to meet ASTM D3315 1/2" dense mixture, Nevada Type II and California 1/2" medium specification (**Table 3**). This gradation was opened up slightly on the #30 and #50 to accommodate the presence of rubber.

Binders

The three grades of neat asphalt used in this research program were obtained from a single California Valley crude source. The binders used were:

Unmodified: AC-5
 AC-20
 AC-40

Both the AC-5 and AC-20 were then modified with crumb rubber. The AC5 was also modified with rubber and an extender oil, yielding a very soft third modified binder. The source of crumb rubber was selected by the sponsor with the rubber being blended with the asphalt cement by Crafcoc Inc., located in Chandler Arizona. The rubber used in this research program was ambient ground rubber having a hydrocarbon content of approximately forty five percent and a specific gravity between 1.100 and 1.200. The particle size, along with the gradation specification suggested by Crafcoc are shown in **Table 4**. The resulting modified binders were:

Modified: AC-5 + 17% Rubber (AC5R)
 AC-5 + 16% Rubber + 5% Extender Oil (AC5RE)
 AC-20 + 16% Rubber (AC20R)

OPTIMUM BINDER CONTENTS

In phase 1 of this research, binder contents to be used in phases 2, 3, and 4 were selected by a committee that included the sponsor and all of the researchers involved. These selections were based on mix designs conducted at both the University of Nevada, Reno and the U.S. Army Corps of Engineers Waterways Experiment Station (WES). Optimum binder contents for both unmodified mixtures, AC5 and AC20, were agreed upon at 5.3 and 5.7 percent by total weight of mix, respectively. However, there was disagreement as to the binder content to use for each of the modified mixtures. As a result, a compromise was made that was agreeable to all parties involved in the extended program. The compromise yielded binder contents that were higher than the UNR recommended optimums. The following table shows the binder contents used and the UNR recommended binder content for all modified mixtures.

TESTING METHODS

After compaction, samples were allowed to cool overnight in a 77°F room prior to being tested for bulk specific gravity and height, ASTM D2726 and D3515, respectively (2). Samples were then placed under a fan, again overnight, to remove any moisture that may have penetrated the sample during testing. Samples were then placed in an appropriate temperature control chamber to condition them to the testing temperature to be used, either 77°F or 104°F. After twenty four to thirty six hours, samples were tested for permanent deformation using one of two tests. These tests are described in detail below.

The first of two tests used was a modified version of the proposed ASTM creep test (4). This test involved static loading, uniaxial, unconfined, creep test. This test incorporated a two minute preconditioning load, using the test load magnitude, followed by a five minute rest period. Immediately following the rest period, a static load was applied for a period of sixty minutes, followed by a fifteen minute unload, or rebound, period, where samples were allowed to rebound freely. Tests conducted at 77°F used a static stress of fifty psi, and tests conducted at 104°F used a static stress of twenty psi.

The second test used to assess permanent deformation was a tri-axial, repeated loading, confined test. This test procedure followed the interim testing guidelines from the SHRP A-003A contractor at the time this testing was started. The only change implemented by UNR was the shortening of the test time from 36,000 cycles (approx. 8 hours) to 5,200 cycles (approx. 1 hour). The test used a one minute preconditioning period followed immediately by a sixty minute test. The repeated loading sequence consisted of 0.1 second duration haversine pulse, followed by a 0.6 second rest period. This sequence yields a testing frequency of 1.43 cycles per second. All tests used a confining pressure of fifteen psi. Tests conducted at 77°F used a peak deviator stress of fifty psi while tests conducted at 104°F used a peak deviator stress of twenty psi.

Deformations were continuously measured for both tests using two linear variable differential transducers (LVDT's). These LVDT's were instrumented 180° apart and measured deformations over the total sample height. These deformations were electronically averaged and recorded every sixty seconds throughout testing.

The data was then used to calculate compressive strains, for each test, over the sample height using the following equation:

$$\epsilon(t) = (d(t)/H_o)$$

Where:

- $\epsilon(t)$ = strain at time t, in/in
- H_o = original height of sample, inches
- $d(t)$ = deformation of sample height at time t, inches

TESTING PROGRAM

A total of seventy two samples, twelve samples from each of the six types of binder, were prepared. This allowed for three replicates to be tested at each testing condition. The testing conditions used were; static load at 77°F, static load at 104°F, repeated load a 77°F and repeated load at 104°F. This testing matrix is shown in **Table 1**. The number of samples tested produced sufficient data to estimate the mean, standard deviation and coefficient of variation for each type of mixture at each testing condition.

ANALYSIS OF TEST RESULTS

As stated previously, there were two different types of permanent deformation tests used in this research program. Then within each test, samples from each of the six mixtures were tested at two different temperatures. For ease of discussion, the analysis will be presented in the same fashion; first the static test results and then the repeated load test results.

Analysis of Static Permanent Deformation Testing

Table 5 shows the average, standard deviation (s), and coefficient of variation (CV) for the strain at sixty minutes (i.e. strain at the end of the loading period) for all tests completed at 77°F, using the static testing procedure. The AC-40 data has been removed from the data base due to sample damage prior to test. It can be seen from this table that the CV is somewhat higher than desired, however, it is still in the range of acceptable test results. This table also shows an average creep modulus for each of the five remaining mixtures. A creep modulus of zero indicates that the samples failed prior to sixty minutes of loading.

Figure 1 shows the average compressive strain versus time relationship for the 77°F static test results. Inspection of this figure shows that the mixtures behaved as expected. The unmodified mixtures show that the AC5 samples fail at about ten minutes into the test while the AC20 samples yield relatively low strains. The asphalt-rubber mixtures show decreasing strain with increasing binder viscosity (i.e. AC5R strains more than AC20R and AC5RE strains more than AC5R). It can be concluded from this figure that for this testing procedure conducted at 77F, the addition of rubber yields mixtures that exhibit less deformation (i.e. asphalt-rubber AC5 strains less than AC5 and asphalt-rubber AC20 strains less than AC20).

Table 6 shows the average, standard deviation (s), and coefficient of variation (CV) for the strain at sixty minutes (i.e. strain at the end of the loading period) for all tests completed at 104F, using the static testing procedure. Once again, the AC40 data has been removed from the data base due to sample damage prior to testing. The CV is again higher than desired, however, it is still in the range of acceptable test results. This table also shows the average creep modulus for each of the five remaining mixtures. A creep modulus of zero indicates that the samples failed prior to sixty minutes of loading.

Figure 2 shows the average compressive strain versus time for four of the six mixtures from the static testing at 104°F. The AC5 samples failed drastically during the preconditioning sequence, leaving no data to present for the testing sequence. This leaves only one unmodified mixture in the figure, the AC20. All three curves for the asphalt-rubber binders fell on top of each other, indicating the same response for any mixture incorporating rubber. All asphalt-rubber mixtures exhibited less strain than the AC20. It is hypothesized that in this case, the rubber is absorbing the load and the strain is therefore independent of the base asphalt cement. It should be remembered that this is for a static, unconfined test.

Figure 3 shows the average creep modulus calculated at sixty minutes of loading for the five mixtures for both temperatures of static testing. It can be seen that the AC5 shows modulus values of zero for both temperatures. This is due to sample failure prior to sixty minutes of loading. The AC20 shows a drop in the modulus of approximately fifty percent from 77°F to 104°F. All three of the asphalt-rubber mixtures showed a smaller drop in stiffness than the AC20. In fact the AC5RE showed an increase in modulus from 77° to 104°. This would indicate that asphalt-rubber mixtures will suffer a smaller loss of stiffness with increasing temperature than unmodified mixtures.

Analysis of Repeated Load Permanent Deformation Testing

Table 7 shows the average, standard deviation (s), and coefficient of variation (CV) for the strain at sixty minutes (i.e. strain at the end of the test) for all tests completed at 77°F, using the repeated loading testing procedure. This table shows data for all six mixtures. It also shows the average creep modulus for each of the six mixtures. This modulus, like the static modulus, was calculated by dividing the strain after sixty minutes of testing into the peak deviator stress.

Figure 4 shows the average compressive strain versus time for the six mixtures from the repeated load testing at 77°F. This figure shows that both the AC5 and AC5RE failed during testing. This due to the relatively low viscosity of the unmodified AC5 and asphalt-rubber AC5 that incorporates an extender oil, which is also of very low viscosity. The AC5R finished the testing without failure, however exhibited large strains. The three mixtures that performed the best were the AC20, AC20R and AC40. It is interesting to note that the AC20R exhibited a higher strain than the AC20. In this case the AC20 samples exhibited strains that grouped the mixtures with the AC40, which yielded very low strain. This anomaly remains unexplained.

Table 8 shows the average, standard deviation (s), and coefficient of variation (CV) for the strain at sixty minutes (i.e. strain at the end of the test) for all tests completed at 104°F, using the repeated loading testing procedure. This table shows data for all six mixtures. It also shows the average creep modulus for each of the six mixtures. The table indicates that the AC5 and AC20 samples failed prior to sixty minutes of loading. This is shown in **Figure 5**. It can be seen from this figure that the AC5 failed after approximately fifteen minutes of loading while the AC20 failed after twenty minutes of loading. This indicates that even though the samples failed, the AC20 mixtures were stiffer than the AC5 mixtures. The AC40 mixtures performed very well, yielding relatively low strains. The modified mixtures yielded strains that also follow

the idea of higher viscosity leads to lower strain. The AC5RE produced the highest strains, followed by the AC5R and the AC20R. The AC5R acted in a similar manner as the AC40, while the AC20R exhibited the lowest amount of strain of any of the six types of mixtures. This indicates that for this particular aggregate source and gradation, an AC5R could be expected to behave like an AC40 in warmer temperatures. An AC20R could be expected to exceed the permanent deformation performance of an AC40. It can be concluded from this that the addition of rubber to the mixture produces a stiffer mixture at higher temperature.

Figure 6 shows the average creep modulus calculated at sixty minutes of loading for the six mixtures for both temperatures of repeated load testing. It can be seen that all unmodified mixtures either exhibited very large decreases in stiffness from 77°F to 104°F or no stiffness at all. On the other hand, the asphalt-rubber mixtures exhibited either very small decreases, or as in the case of the AC5RE, showed an increase in stiffness. This again indicates that the addition of rubber to asphalt concrete mixtures reduces the magnitude of the loss of stiffness at higher temperatures.

Comparison of Static to Repeated Load Permanent Deformation Testing

The relative ranking of strain changes for both testing conditions when 77°F test results are compared to 104°F test results. The 77°F test results are useful to assess the loss in stiffness when compared to testing at 104°; however, because of the low testing temperature, they do not appear to be appropriate for characterization of permanent deformation.

The static test results at 104°F indicate only the presence of rubber and nothing about the properties of the asphalt-rubber blend. The repeated load testing at 104°F indicates, in a concrete manner, the differences that exist between the different binders. This is supported by comparing the static testing at 104°F (**Figure 2**) to the repeated load testing at 104° (**Figure 5**).

Based on the information presented in **Tables 5 through 8 and Figures 1 through 6**, two conclusions can be made. First, permanent deformation testing should be carried out at elevated temperatures. Not only does rutting occur primarily at the elevated temperatures, but the modified mixtures appear to react differently at the lower temperatures. This conclusion is supported by both the static and repeated load test results. Secondly, permanent deformation testing should be based on repeated loading. Static testing only indicates the presence of rubber and nothing about the base asphalt.

CONCLUSIONS

Based on the analysis presented in this paper, the following conclusions can be drawn:

1. The addition of ground tire rubber to asphalt concrete mixtures results in mixtures that exhibit less permanent deformation at high temperatures compared to unmodified mixtures, remembering that the asphalt-rubber mixtures contained higher than optimum asphalt contents. This proved to be true for both static and repeated load testing.
2. Permanent deformation testing should be carried out at elevated temperatures. This conclusion is supported by both the static and repeated load test results. The relative ranking of strain changes for both testing conditions when the 77F test results are compared to the 104°F test results.
3. Permanent deformation testing should incorporate repeated loading. This is not only a better model for including the effects of moving wheel loads, but is supported by comparing the static testing at 104F to the repeated load testing at 104°F. The static test results indicate only the presence of rubber and nothing about the properties of the base binder. The repeated load testing indicates, in a concrete manner, the differences that exist between binders.

ACKNOWLEDGEMENT

The authors would like to thank the Asphalt Rubber Producers Group, U.S. Army Corps of Engineers, University of Arizona, and Crafcro Inc., for their support and cooperation in this research program.

BIBLIOGRAPHY

1. Stroup-Gardiner, M., Krutz, N.C., Epps, J.A., "Comparison of Mix Design Methods for Rubberized Asphalt Concrete Mixtures", Proceedings of the Asphalt Rubber Producers Group, October 1989.
2. ASTM "Road and Paving Materials; Traveled Surface Characteristics", 1990 Edition.
3. Chehovits, J.G., "Design Methods for Hot-Mixed Asphalt-Rubber Concrete Paving Materials", Written for the Asphalt Rubber Producers Group.
4. ASTM Sub-committee D04.20 "Proposed Standard Test Method for Unconfined Static Creep Test on Asphalt Mix Specimens", December, 1988.

Table 1: Test Matrix for Permanent Deformation of Modified and Unmodified Mixtures

	Binder	AC5 Ext. Oil		AC5		AC20		AC40	
	Modifier	Orig.	Rubber Added	Orig.	Rubber Added	Orig.	Rubber Added	Orig.	Rubber Added
Static Load	77°F		X	X	X	X	X	X	
	104°F		X	X	X	X	X	X	
Repeat. Load	77°F		X	X	X	X	X	X	
	104°F		X	X	X	X	X	X	

TOTAL OF 72 SAMPLES (each X denotes 3 samples)

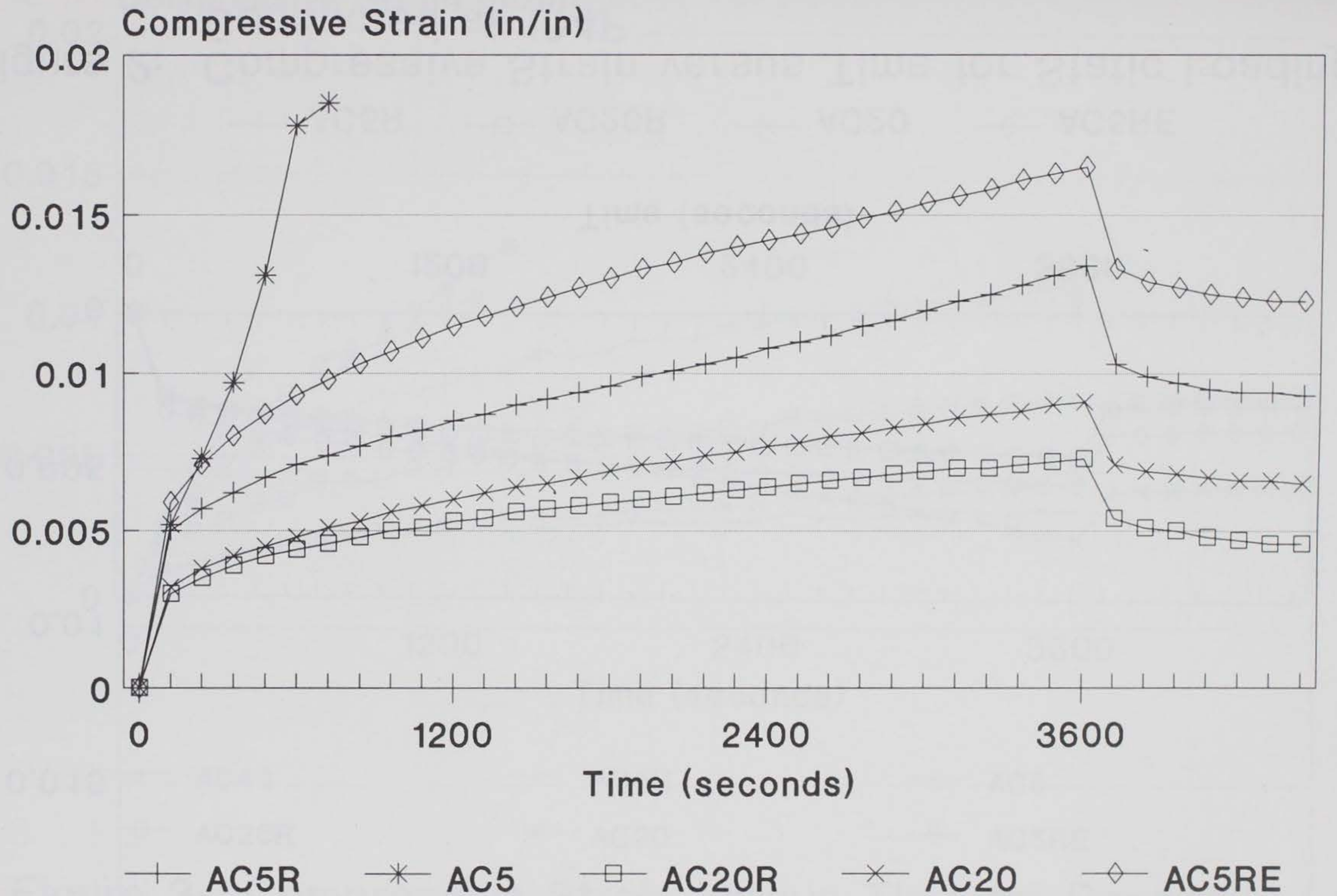

Figure 1: Compressive Strain versus Time for Static Loading Conducted at 77F

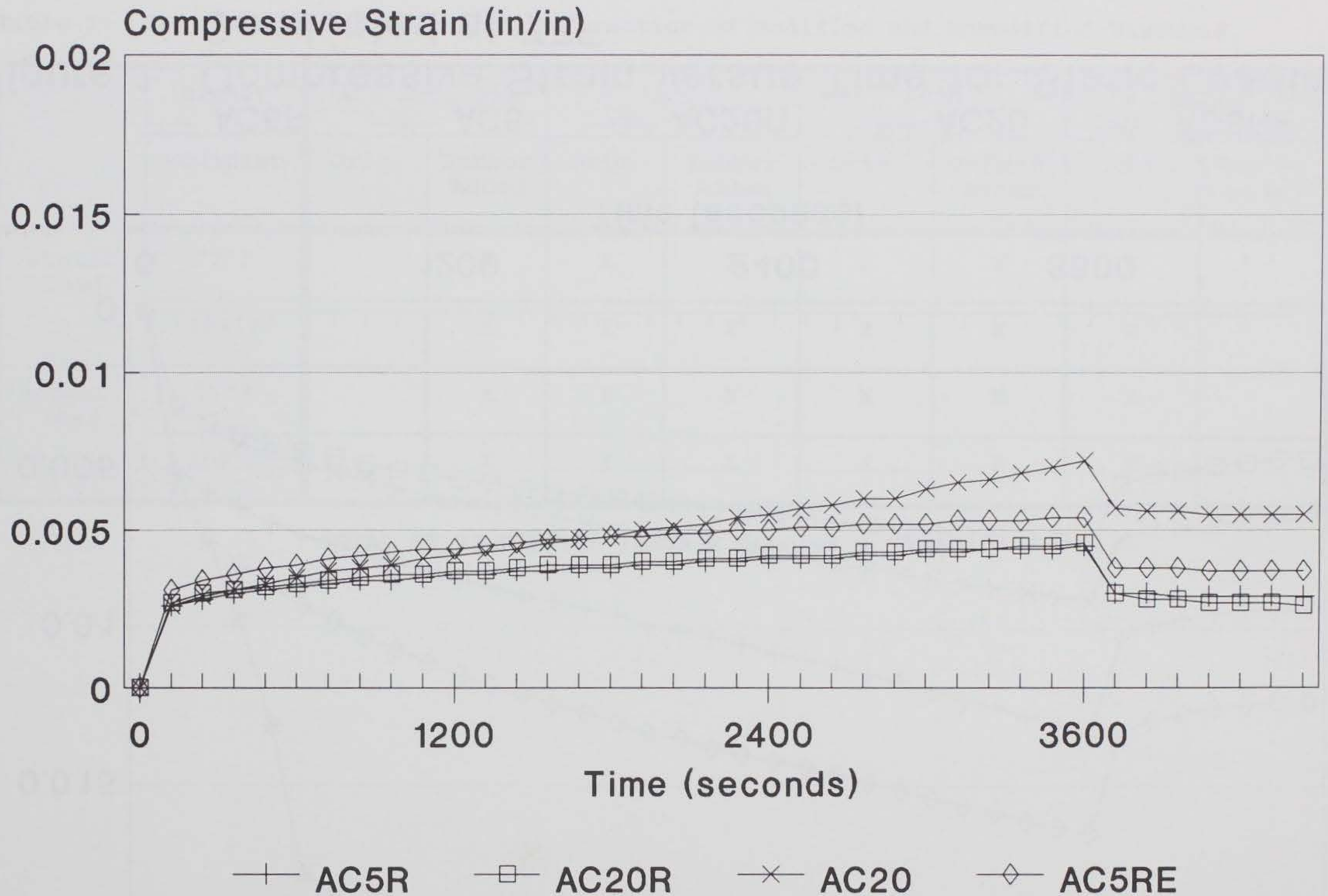

Figure 2: Compressive Strain versus Time for Static Loading Conducted at 104F

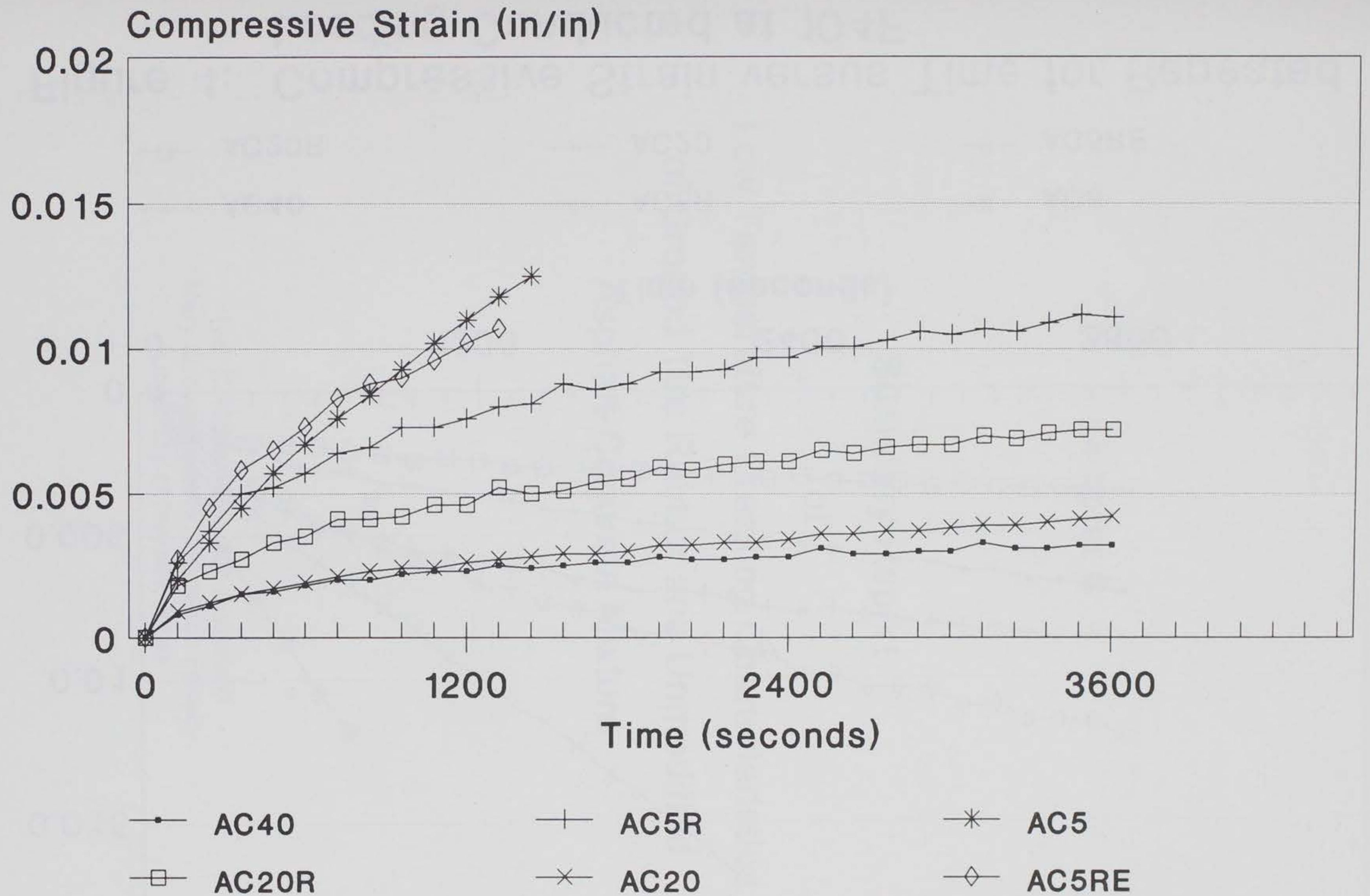

Figure 3: Compressive Strain versus Time for Repeated Loading Conducted at 77F

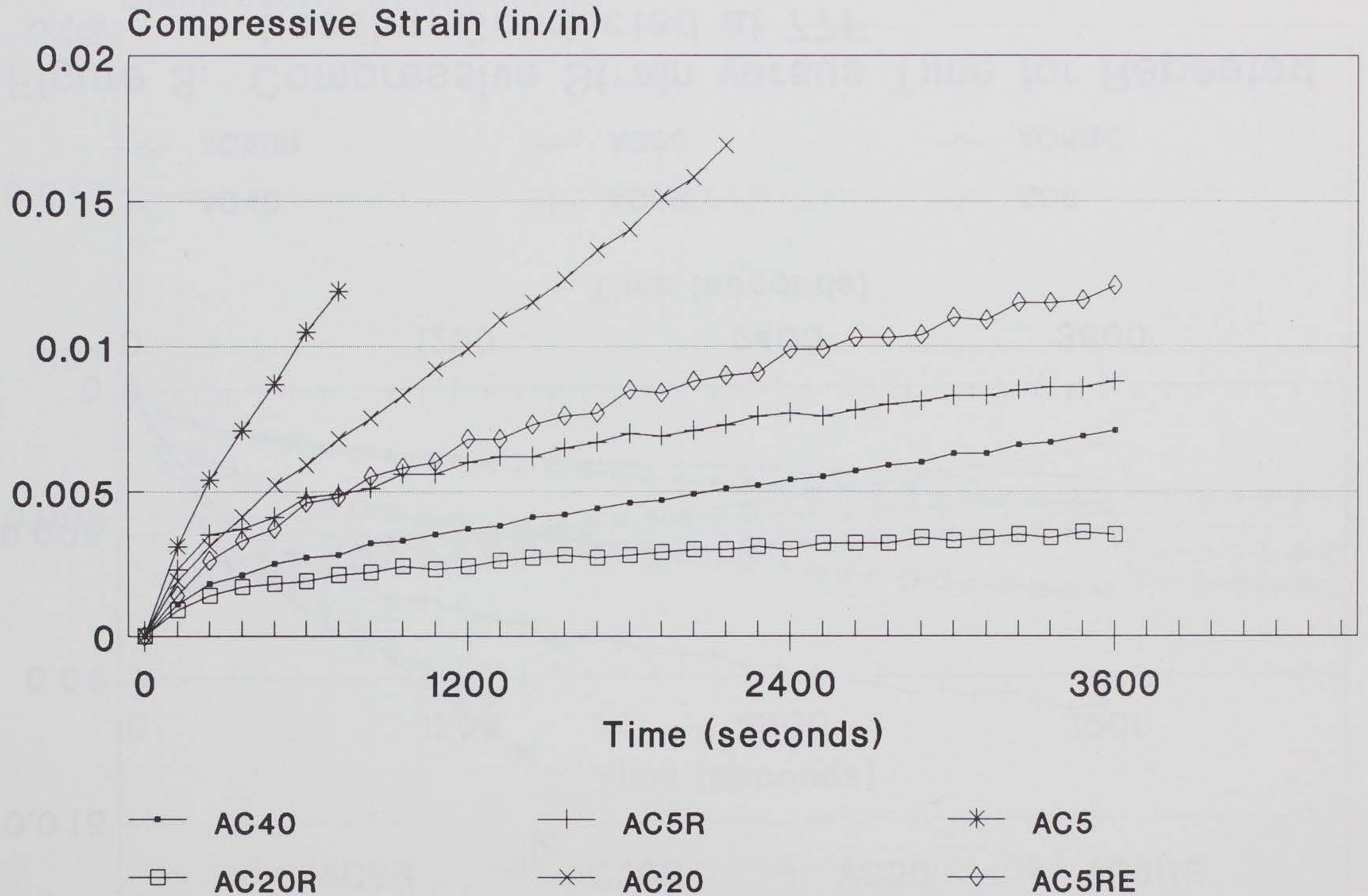

Figure 4: Compressive Strain versus Time for Repeated Loading Conducted at 104F

Chapter 6

Summary Report

of

Low Temperature Cracking Characteristics of Ground Tire Rubber and Unmodified Asphalt-Concrete Mixture

by

**Neil C. Krutz, Research Associate
Mary Stroup-Gardiner, Research Faculty
University of Nevada, Reno**

ABSTRACT

In recent years, modified asphalt mixtures have become increasingly popular in the construction of flexible pavements. These products have gained popularity because of their ability to increase resistance to rutting at warm temperatures while reducing the occurrence of thermal cracking at cold temperatures. This coupled with the growing problem of waste rubber tires, has led to the reprocessing (grounding) of tire rubber for use in asphalt concrete mixtures.

In order to investigate the low temperature cracking hypothesis, a laboratory research program utilizing, constrained specimen, indirect tension, and direct tension tests, was designed in order to assess the potential benefits of asphalt-rubber concrete mixtures.

Conclusions from this research indicated that the addition of ground tire rubber to asphalt concrete mixtures results in mixtures that exhibit more deformation prior to failure while maintaining similar indirect tensile strength. The research also indicated, through constrained specimen testing, that the addition of ground tire rubber to soft base asphalts (i.e. AC5) resulted in a mixture that exhibited transition and fracture temperatures approximately 10°C (18°F) lower than that of the unmodified mixture.

Table of Contents

INTRODUCTION	84
BACKGROUND	84
Historical Methodology Used in Assessing Thermal Stresses	84
State of the Art Methodology Used In Assessing Thermal Stresses	85
RESEARCH PROGRAM	87
MATERIALS	87
Aggregates	87
Binders	88
OPTIMUM BINDER CONTENTS	88
SAMPLE PREPARATION	89
TESTING METHODS	90
TESTING PROGRAM	91
ANALYSIS OF TEST RESULTS	91
Constrained Specimen Test Results	91
Indirect Tension Test Results.....	93
Direct Tension Tet Results	94
Analysis of Aging Sample Test Results	94
CONCLUSIONS.....	96

INTRODUCTION

In recent years, modified asphalt mixtures have become increasingly popular in the construction of flexible pavements. These products have gained popularity because of their ability to increase resistance to rutting at warm temperatures while reducing the occurrence of thermal cracking at cold temperatures. This coupled with the growing problem of waste rubber tires, has led to the reprocessing (grounding) of tire rubber for use in asphalt concrete mixtures. In order to investigate this hypothesis, a laboratory research program was designed in order to assess the potential benefits of asphalt-rubber concrete mixtures.

BACKGROUND

Low temperature cracking is associated with the volumetric contraction that occurs as a material experiences a temperature drop (1). Materials that are unrestrained will shorten as the temperature drops. However, if a material is restrained, such as the case of asphalt concrete in a pavement structure, the attempt to shorten results in the development of thermal stresses. When these thermal stresses become equal to the tensile strength of the material, a crack is formed.

Asphalt cement, and as a result asphalt concrete, exhibit two coefficients of thermal contraction (1). These are called the glassy and fluid coefficients. The temperature at which the change takes place is called the glass transition temperature. For temperatures warmer than the transition temperature, the asphalt exhibits the fluid coefficient of contraction, while at temperatures colder than the transition temperature the glassy coefficient of contraction is seen. This indicates that the physical properties of asphalt are significantly different in the fluid or glassy states.

Both asphalt cement and asphalt concrete can be considered to act as viscoelastic materials at warm temperatures (i.e. fluid coefficient) (1). This allows for the dissipation of thermal stresses through stress relaxation. However, at colder temperatures, asphalt concrete behaves as an elastic material and thermal stresses can not be dissipated until a crack initiates (i.e. glassy coefficient). The temperature at which a crack occurs is referred to as the fracture temperature. Once a failure occurs and a crack develops, the stresses are relieved.

In newly constructed asphalt concrete pavements, cracks have been observed to develop 100+ feet of spacing, and as the pavement ages, the crack spacing has been observed to decrease to ten to twenty feet (1).

Historical Methodology Used in Assessing Thermal Stresses

Many researchers have attempted to calculate thermal stress of asphalt concrete pavements. Hill and Brien (2) calculated the thermal stresses associated with an infinite, completely restrained strip. The equation used took into account the average coefficient of

contraction, initial and final temperatures, and the asphalt mix stiffness (dependent upon time and temperature).

Monismith, et al. (3), used a stress equation developed by Humphreys and Martin (4) to predict thermal stresses in a slab of linear viscoelastic material that was subjected to a time dependent temperature field. The slab was assumed to be of infinite lateral extent and completely restrained. However, in 1969, Haas and Topper indicated that the stresses predicted were unrealistically high (5). They concluded that if Monismith's solution was modified to use a long beam instead of slab, the computed stresses were slightly underestimated (6). This leads back to the approximate solution suggested by Hill and Brien (2), called the pseudo-elastic beam analysis. This solution was supported by Christison and Anderson in 1972 (7), and by two test roads (8,9,10). This methodology was further supported by Finn et al., in 1986 using the Cold model to predict low temperature cracking (11).

Thermal stress relationships have also been obtained through indirect estimation. For example, the binder stiffness-temperature relationship at an appropriate (but arbitrary) loading time, may be estimated from the Penetration Index, softening point values and van der Poel's nomogram (1). This binder stiffness-temperature relationship can then be converted to an asphalt mixture stiffness based on the volumetric portions of binder and aggregate present in the mix. Then using an assumed or measured coefficient of thermal contraction, the stress-temperature relationship is obtained using the solution proposed by Hill and Brien (2).

A second form of indirect estimation of thermal stress relationships is based on the load-deformation response of asphalt concrete at cold temperatures. Creep, flexural bending, direct tension, and indirect diametral tension tests have all been used to measure the load-deformation response of asphalt concrete mixtures (3,6,7,12). Previous research has indicated that by multiplying the stress-strain response (load-deformation) of a mixture by the measured or assumed coefficient of thermal contraction, the thermal stress relationship can be estimated.

The development of thermal stresses have also been measured directly in the laboratory (3,13,14,15). This was accomplished by measuring the stress required to maintain a specimen at constant length under a constant rate of cooling. Direct measurement eliminates the need to measure or assume a coefficient of thermal expansion of a mixture.

In 1974, Fabb considered three rates of cooling (5, 10, and 27°C/hr) and concluded that the rate of cooling has little or no effect on the failure temperature (13). However, in 1980, Bloy established that differences in rates of cooling below 5°C/hr did influence the temperature at which cracking occurred in asphalt cements, whereas differences in rates of cooling above 5°C/hr had no influence (16).

State of the Art Methodology Used In Assessing Thermal Stresses

In May of 1990, NCHRP published a procedural manual for design of asphalt concrete mixtures (17). This manual outlines procedures for conducting indirect tensile strength tests and

indirect tensile creep tests. The indirect tensile strength test uses a loading rate of 0.05 inches per minute and measures the peak stress obtained. The indirect tensile creep test then conducted on samples using a static load of between five and twenty percent of the indirect tensile strength. The static load is maintained for one hour and then the sample is allowed to rebound for another hour. Vertical and horizontal deformation are monitored throughout the test. The horizontal deformation at the end of the sixty minute load is used to calculate the indirect tensile creep modulus. Both the indirect tensile strength and indirect tensile creep tests are conducted at various temperatures to define the strength-temperature, creep modulus-temperature, and strength modulus relationships.

The manual then gives an equation which estimates the critical change in temperature at which cracking will occur. This equation is based on the following.

Indirect Tensile Creep Modulus at temperature T_i ;

Slope and Intercept of Indirect Tensile Creep Curve at temperature T_i ;

3,600 seconds of relaxation time

Assumed coefficient of thermal contraction between $1.0E-5$ and $1.8E-5$ in/in/°F

It is also possible to calculate the decrease in thermal stress due to stress relaxation and change in thermal stress due to a drop in temperature using the various combinations of the variables listed above.

Work being completed in the Strategic Highway Research Program (SHRP) contract A003A has also addressed the problem of low temperature cracking. Research conducted under this program has addressed the direct measurement of thermally induced stresses on restrained specimens. To date, the results indicate that as the temperature of the specimen is dropped, the asphalt concrete will exhibit stress relaxation down to a certain temperature, a transition temperature, followed by purely elastic behavior. This is shown graphically in Figure 1.

It can be seen from this figure that the slope of the line changes considerably during testing. As the temperature becomes colder, the slope increases until becoming linear. The point at which the slope becomes constant is termed the transition temperature. Above this temperature the asphalt concrete still possesses viscoelastic characteristics, or in other words, the thermal stresses induced can be relieved through stress relaxation. However, below the transition temperature, the asphalt concrete possesses purely elastic characteristics. The thermally induced stresses are not relaxed until failure of the specimen.

The A003-A researchers have found that the transition temperature is dependent upon mixture properties such as air void content. As the air void content increases the transition temperature decreases. The transition temperature has also been found to be related to the fracture temperature of the mixture. As the transition temperature decreases, so does the fracture temperature. This is shown graphically in Figure 2.

All of the research to date is indicating the lower the transition temperature of the mixture, the better the mixture will perform when considering low temperature cracking. This

idea is supported by the stress relaxation (viscoelastic behavior) that is seen when above the transition temperature. Based on this hypothesis, measurement of both the fracture strength and the transition temperature is necessary for proper characterization of low temperature properties.

RESEARCH PROGRAM

The extended research program was designed to include four phases:

Phase 1: The use of conventional mix design methods for determining the optimum asphalt content for asphalt-rubber mixtures.

Phase 2: Permanent deformation characteristics of asphalt-rubber and unmodified mixtures.

Phase 3: Low temperature cracking resistance of asphalt-rubber and unmodified mixtures.

Phase 4: Fatigue cracking resistance of asphalt-rubber and unmodified mixtures.

This report will deal with the laboratory results from Phase 3 only. Phase 1 has been completed and reported in "Comparison of Mix Design Methods for Asphalt-Rubber Concrete Mixtures" (18). Phase 2 has also been completed and reported in "Permanent Deformation Characteristics of Recycled Tire Rubber Modified and Unmodified Asphalt Concrete Mixtures" (19). Phase 4 is currently being completed by the University of Arizona (UA) and the U.S. Army Corps of Engineers Waterways Experiment Station (WES).

The scope of this research program included one aggregate source, one gradation and five binders. The test matrix is shown in Table 1.

MATERIALS

Aggregates

The aggregates used in this research program were obtained from Granite Rock Company, located in Watsonville California. This material is a 100 percent crushed granite that has no history of stripping problems with in-service pavements. The physical properties of the aggregate are shown in Table 2.

The gradation used to prepare the mixture samples is shown in **Table 3**. This gradation was chosen to meet ASTM D3315 1/2" dense mixtures, Nevada Type II and California 1/2" medium specification (Table 3). This gradation was opened up slightly on #30 and #50 to accommodate the presence of rubber.

Binders

The two grades of neat asphalt cement used in this phase of the research program were obtained from a single California Valley crude source. The binders used were:

Unmodified: AC5
 AC20

Both the AC5 and AC20 were then modified with crumb rubber. The AC5 was also modified with rubber and extender oil, yielding a very soft third modified binder. The source of crumb rubber was selected by the sponsor with the rubber being blended with the asphalt cement by Crafcoc Inc., located in Chandler Arizona. The rubber used in this research program was ambient ground rubber having a hydrocarbon content of approximately forty five percent and a specific gravity between 1.100 and 1.200. The particle size, along with the gradation specification suggested by Crafcoc are shown in **Table 4**. The resulting modified binders were:

Modified: AC5 + 17% Rubber (AC5R)
 AC5 + 16% Rubber + 5% Extender Oil (AC5RE)
 AC20 + 16% Rubber (AC20R)

OPTIMUM BINDER CONTENTS

In phase 1 of this research, binder contents to be used in phases 2, 3, and 4 were selected by a committee that included the sponsor and all of the researchers involved. These selections were based on mix designs conducted at both the University of Nevada, Reno and the U.S. Army Corps of Engineers Waterways Experiment Station (WES). Optimum binder contents for both unmodified mixtures, AC5 and AC20, were agreed upon at 5.3 and 5.7 percent by total weight of mix, respectively. However, there was disagreement as to the binder content to use for each of the modified mixtures. As a result, a compromise was made that was agreeable to all parties involved in the extended program. The compromise yielded binder contents that were higher than the UNR recommended optimums. The following table shows the binder contents used and the UNR recommended binder content for all modified mixtures.

Type of Binder	Binder Content Used In Preparing Samples (%, Total Weight of Mix)	UNR Recommended Binder Content (%, Total Weight of Mix)
AC5R	8.5	7.7
AC5RE	8.3	7.7
AC20R	7.9	7.4

SAMPLE PREPARATION

Samples were batched by first separating the aggregates into the eleven individual sizes (1/2", 3/8", 1/4", #4, #8, #16, #30, #50, #100, #200, fines) needed to prepare samples, and then recombined to meet the desired gradation. Washed sieve analysis were performed on complete batches to ensure the gradation had been met.

After all aggregate preparation was completed, batches were selected at random and mixed with the selected binder. Different methods of mixing were used for the asphalt-rubber and unmodified mixtures. Samples were also compacted to achieve approximately six to eight percent air voids. This resulted in using different levels of compaction for the various mixtures used in this research program. The procedures for mixing and compaction are described below.

Unmodified mixtures were mixed in accordance with ASTM D 1561 (20). After mixing, samples were placed in a 140°F forced draft oven for fifteen hours prior to being reheated to 230°F for compaction. Asphalt-rubber mixtures were mixed using the recommendation of Chehovits (21). This involves heating the aggregate to 300°F and the asphalt-rubber binder, regardless of base asphalt viscosity, to 350°F prior to mixing. Once again, after mixing, samples are placed in a 140°F forced draft oven for fifteen hours prior to reheating the samples for compaction.

All samples were compacted with a kneading compactor. Two types of samples were prepared for testing under this phase of the research, normal 2 1/2" in height in 4" in diameter briquettes and 3" deep by 3" wide by 16" long beams. Unmodified briquettes were compacted using 30 blows at 250 psi. This was followed by curing for 1 1/2 hours at 140°F prior to the application of an 11,000 lb leveling load. Samples were then allowed to cool before being extruded.

Asphalt-rubber briquettes using AC20R were reheated to 300°F for compaction, while the other two asphalt-rubber mixtures (AC5R and AC5RE) were reheated to 230°F for compaction. Compaction of all asphalt-rubber briquettes consisted of 30 blows at 250 psi. Briquettes of AC20R were cured in a 140°F oven for 2 1/2 hours prior to the application of an 11,000 lb leveling load. Samples of AC5R and AC5RE were cured in a 140°F for 1 1/2 hours prior to the application of an 11,000 lb leveling load. All samples were allowed to cool and were then extruded.

Unmodified beam specimens were compacted in two lifts. The first lift consisted of two thirds of the material needed for the beam and received twenty blows at 75 psi. The second lift consisted of the other third of the material. The specimen then received forty blows at 75 psi, forty blows at 100 psi, and forty blows at 200 psi. This was immediately followed by level loading to 10,000 lbs. Beam specimens were then allowed to cool prior to extruding.

Asphalt-rubber beam specimens, regardless of binder type, were reheated to 230°F prior to compaction. These beam specimens were also compacted in two lifts, with the first lift

consisting of two thirds of the mixture needed. This lift received twenty blows at 75 psi. The second lift, consisting of the other third of the material needed, was then placed in the mold. The specimen then received forty blows at 75 psi. The completed specimen then was level loaded immediately to 10,000 lbs. Specimens were then allowed to cool before being extruded. The low amounts of compactive effort needed to fabricate asphalt-rubber beams is due to the dilatant (shear shinning) characteristics of the asphalt-rubber. The kneading action used in producing beams imparts a large amount of shear to the mixture. This resulted in relatively low amounts of needed energy to compact asphalt-rubber beams to the appropriate air void content.

After all beam specimens, asphalt-rubber and unmodified, were allowed to cool overnight in a 77°F room, they were sawed to 2 inches in depth by 2 inches in width by 10 inches in length for testing. This was done to provide cut surfaces on each face of the sample, in order to remove the irregularities that are associated with laboratory compacted samples. Selected samples from both briquettes and beams were subjected to accelerated laboratory aging in order to assess the effects of aging on both the unmodified and asphalt-rubber mixtures. The aging method used is consistent with NCHRP 9-6(1) AAMAS. This method consists of subjecting compacted briquette and beam, in this case sawed, specimens to forty eight hours of forced draft oven heating at 140°F followed by 120 hours of forced draft oven heating at 225°F. Samples were then cooled to testing temperature and tested according to the appropriate testing sequence.

TESTING METHODS

Following compaction, saw cutting, and/or aging, samples were allowed to cool in a 77°F room prior to being tested for bulk specific gravity and height. All heights were determined in accordance with ASTM D3515 (20). Bulk specific gravity of compacted briquettes was conducted in accordance with ASTM D2726. The bulk specific gravity of sawed beams was determined using a modified version of the paraffin coated procedure. This procedure uses a removable film called "Parafilm. This paraffin based film is commercially available and was used to ensure that no water was being absorbed into the cut surfaces of the aggregate. This test method is currently being addressed by ASTM for an alternate to D1188 (paraffin). Samples were then placed under a fan, again overnight, to remove any moisture that may have penetrated the sample during bulk specific gravity testing. Samples were then placed in an appropriate temperature control chamber to condition them to the testing temperature. After a minimum of twenty four hours in that particular temperature control chamber, samples were tested for low temperature cracking characteristics using one of three methods. The procedures used for these testing methods are described below.

The first of three tests used to assess low temperature cracking was a constrained specimen test. Sawed beams were glued to platens that connected to the loading frame with universal joints. Universal joints were used in order to remove any eccentricity that may result from the gluing process (Figure 3). Testing started at 5°C with the sample held at a constant length through the use of a closed loop testing system. The temperature in the chamber was dropped at a rate of 10°C per hour. The resulting load, induced by the sample trying to shrink, was measured constantly and recorded every minute. The temperature on the surface of the

specimen was also monitored throughout the test, allowing a temperature versus load relationship to be obtained for each specimen tested. The test was considered to have ended when a sample fails in a brittle manner or thirty minutes after peak load in the case of ductile failure.

The second test method used to assess low temperature cracking was the indirect tension test. This test used the conventional size briquets (i.e. 2 1/2" by 4") and tested them in the diametral position. A tensile load was achieved by applying a compressive load across the diameter of the specimen, parallel to the height, **Figure 4**. Samples of each mixture were tested at 34°F, 0°F, and -20°F. A constant loading rate of 0.01 inches per minute was used for all tests. The peak load for each specimen was recorded for analysis.

The third and final test method used to assess low temperature cracking was a direct tension test. This test also made use of the sawed beams. Specimens were glued to platens and mounted to the loading frame in a manner consistent with that used to test constrained specimens. Samples were tested at -20°F using a constant loading rate of 0.01 inches per minute. Once again, the peak load achieved during testing was recorded.

TESTING PROGRAM

A total of 99 samples were prepared for testing. This allowed for three replicates to be tested under each testing condition. The testing matrix is shown in **Table 1**. The replicate samples tested provided sufficient data to estimate the mean, standard deviation, and coefficient of variation for each type of mixture tested for each condition.

ANALYSIS OF TEST RESULTS

As stated previously, there were three types of low temperature cracking tests used in this research program. For ease of discussion, the analysis will be presented in the same fashion, first the constrained specimen, followed by the indirect tension, and finally the direct tension test results.

Constrained Specimen Test Results

As stated previously, the data derived from constrained specimen testing consists of the induced tensile load versus temperature relationship. From this relationship it is possible to retrieve the transition temperature (T_t), the fracture temperature (T_f), and the peak load (i.e. load just before fracture).

Figure 5 shows the average induced tensile load versus temperature relationship for mixtures using the unmodified AC5 (individual test results are shown in appendix A). It can be seen from this figure that average transition temperature is approximately -12°C (10°F). **Table 5** shows the individual data for peak load and fracture temperature as well as the average, standard deviation, and coefficient of variation (CV) for each, for samples using AC5. This table indicates that an average peak load of 287 psi was achieved and that the average fracture

temperature was -26°C (-15°F). CV's for the peak load and fracture temperature are 7.3% and 9.7%, respectively. This data indicates that the test results show very good repeatability.

Figure 6 shows the average induced tensile load versus temperature relationship for mixtures using the unmodified AC20 (again, the individual test results are shown in appendix A). This figure shows an average transition temperature of approximately -11°C (12°F). **Table 6** shows the individual data for peak load and fracture temperature as well as the simple statistics that are shown in **Table 5**. This table shows an average peak load of 278 psi and an average fracture temperature of -25°C (-13°F). Once again, the test repeatability is very good (CV's of 11.2% for the peak load and 4.3% for the fracture temperature). It is interesting to note that all three types of data, T_t , T_f , and peak load, are approximately the same for both grades of unmodified asphalt. This leads to the hypothesis that the controlling factor might be the source of the crude petroleum used in refining the asphalt cement.

Figure 7 shows the average induced tensile load versus temperature relationship for the asphalt-rubber AC5 (AC5R). The figure indicates a transition temperature for the AC5R of approximately -22°C (-8°F), considerably lower than the unmodified AC5. **Table 7** shows the individual test results and simple statistics for the AC5R. This table shows an average peak load of 237 psi and an average fracture temperature of -34°C (-29°F). It can be seen that the CV for the peak load remains very low, at 8.9%, while the CV for the fracture temperature jumps to 20.8%. This is somewhat higher than would be hoped for, but is still in the range of acceptable data.

The average induced tensile load versus temperature relationship for the asphalt-rubber AC20 (AC20R) is shown in **Figure 8**. This figure signifies a transition temperature of -14°C (7°F). After seeing the reduction in transition temperature for the AC5R, the AC20R data is somewhat disappointing. **Table 8** shows individual data for peak load as well as the simple statistics used in earlier tables. It can be seen that the average peak load is 157 psi and the average fracture temperature is -25°C (-13°F). Inspection of the CV for each type of data indicates that peak load is consistent, $\text{CV} = 12.7\%$, but that the fracture temperatures obtained from the test are extremely undesirable, $\text{CV} = 45.8\%$. It is hypothesized that the rubber swells during mixing due to the absorption of the lighter weight molecular particles of the asphalt cement. This tends to leave the asphalt phase of the binder system with the heavier oil and resins. This could result in an increase in binder viscosity and hence mixture stiffness. Also, the heterogeneity of the composition of the failure some cross section could be contributing to the increased testing variability (i.e. increases in CV). This is due to the random and not always uniform distribution of the rubber phase of the binder system.

This could explain to some extent the increase in the fracture temperature CV for the AC5R. It would also explain the conclusion that the addition of rubber to an AC20 to improve its low temperature cracking properties is not a good approach. A softer binder should be used, preferably one that will provide enough light ends to have a percentage of them remaining in the asphalt cement phase of the binder system.

According to Table 1, three samples of AC5RE were to be tested using the constrained specimen test. This testing was unable to be completed because the beam specimens using this extremely soft binder literally fell apart with any sort of handling.

Indirect Tension Test Results

Data obtained from the indirect tension testing consisted of the peak load achieved during testing. Understanding that the peak load alone does not give a complete picture of material stiffness, the approximate testing time was also recorded. This data will help to give a more complete picture of how the various mixtures behave under diametral loading.

Figure 9 shows the average indirect tensile strength for all five mixtures tested at 34°F (1°C). Visual inspection shows both of the unmodified mixtures are considerable stronger than any of the asphalt-rubber mixtures. Inspection of **Table 9**, which shows individual test results as well as the average, standard deviation, and coefficient of variation, indicates that there is overall good repeatability.

Figure 10 shows the average indirect tensile strength for all five mixtures tested at 0°F (-18°C). This figure shows that all three mixtures using the AC5 (AC5 AC5R, and AC5RE) are approaching equal tensile strength. This is regardless of the presence of rubber or extender. The figure also indicates that at this temperature the AC20R mixture is stiffer than the AC20 mixture. **Table 10** shows that the repeatability (CV) has dropped considerably from the 34°F test results. This loss of repeatability hampers the ability to make firm conclusions, however, general trends can still be identified. In general, a trend of the asphalt-rubber mixtures nearing or exceeding the tensile strength of the unmodified mixtures.

It is interesting to note that unmodified mixtures took approximately ten to twelve minutes of loading to achieve failure while the rubber modified mixtures needed approximately twenty minutes of loading to achieve failure. These times to failure are only approximate, however, they do indicate that the asphalt-rubber mixtures exhibit more deformation prior to failure.

Figure 11 shows the average indirect tensile strength for all five mixtures tested at -20°F (-29°C). Visual inspection of this figure shows very little difference between any of the mixtures. This indicates that all five mixtures are exhibiting "glass" characteristics. Once again, however, the asphalt-rubber mixtures required more loading time to achieve failure than the unmodified mixtures. The asphalt-rubber mixtures required approximately ten to twelve minutes to fail while the unmodified mixtures required approximately five to seven minutes to fail. This again, signifies that the asphalt-rubber mixtures failed in a more ductile manner than the unmodified mixtures. **Table 11** shows the individual data, average, standard deviation, and coefficient of variation for all five mixtures tested at -20°F (-29°C). This table indicates that there is very good repeatability within each mixture. This leads to the conclusion the for this test method, conducted at -20°F (-29°F), the mixtures exhibit similar tensile strength but the asphalt-rubber mixtures are the more ductile material.

Figure 12 compares the indirect tensile strength test results at all three temperatures. This figure shows the average indirect tensile strengths for each of the five mixtures at all three testing temperatures. It can be seen that at 34°F (1°C) the asphalt-rubber mixtures are softer than the unmodified mixtures, but that at 0°F (-18°C) the mixtures approach equal strength. Test results at -20°F (-29°C) indicate the two mixtures incorporating AC20 peaked in strength at 0°F (-18°C). The other three mixtures are still exhibiting increasing strength. This suggests that the AC20 and modified AC20 (AC20R) will be the most brittle at cold temperatures.

Direct Tension Test Results

Data obtained from the direct tension testing also consisted of the peak load achieved during testing. Figure 13 shows the average test results from all five mixtures tested at -20°F (-29°C). Visual inspection shows very little difference between any of the mixtures. Inspection of **Table 12** shows that the test repeatability is acceptable. Ideally, the CV for each mixture would be below 15%, however, the range obtained from this testing can still be used to make conclusions about the data. The conclusion here is that the extremely low temperature properties of each mix will be similar in as much as they all contain the same supplier of asphalt cement.

Efforts were made to see if there was a correlation between tensile strength determined from indirect method and from the direct method. **Figure 14** shows the average tensile strength values from all five mixtures for both the indirect and direct testing methods. The data indicates that there is very little difference between the data derived from the tests. This is most likely due to the fact that all mixtures are behaving in a similar manner at this temperature (-20°F or 29°C). This leaves no real basis to compare the tests themselves. In order to properly assess the differences between the tests, there would need to be differences from mixture to mixture.

Analysis of Aging Sample Test Results

Table 1 indicates that there were samples prepared for constrained specimen, indirect tension, and direct tension testing that were to be subjected to accelerated oven aging prior to testing.

This figure indicated that three samples each of AC5, AC5R, and AC5RE were to be tested using the constrained specimen method. Unfortunately, all beam samples suffered some sort of crumbling of the cut surface during the aging process. Attempts were made to cut the specimens to lengths that contained no damage, however, the data obtained from these efforts was unusable. This leads to the conclusion that cut beams, in particular those containing a relatively soft base asphalt, will tend to crumble at the elevated temperatures used in the NCHRP AAMAS accelerated aging process. It should be noted that these problems were not encountered with the briquettes. Therefore, the accelerated aging testing was completed on the aged briquettes with no problems encountered.

Table 1 indicates that three samples of the mixture using AC5 were to be tested at 0°F (-18°C) utilizing the indirect tension test method. The average indirect tensile strength from this

testing is shown along side the unaged AC5 test results in **Figure 15**. It can be seen from this graph that there is approximately a twenty five percent increase in indirect tensile strength after the oven aging. This is further supported by the low coefficient of variation for this testing (**Table 13**).

Three samples of mixture using the AC5R binder were also tested for indirect tensile strength at 0°F (-18°C). The average indirect tensile strength for this testing is shown along side the unaged test results in **Figure 16**. This data also shows an increase in indirect tensile strength of approximately twenty five percent. However, this data showed very poor repeatability (CV of 40.4%). Therefore, it is hard to draw any tangible conclusions.

Figure 17 shows the average indirect tensile strength for both aged and unaged samples of mixture using AC5RE for all three temperatures used for the indirect tension testing. Inspection of this figure shows that for both the 34°F (1°C) and 0°F (-18°C) testing temperatures, there is approximately a seventy percent increase in tensile strength from unaged to aged test results. Data obtained at -20°F (-29°C) indicates a tensile strength increase of approximately thirty five percent. It is hypothesized that at the two warmer testing temperatures, the asphalt-extender phase of the binder system is absorbing the load, and not the rubber. Therefore the largest increases in tensile strength are noticed at these temperatures because the extender oil and the light ends of the asphalt cement are the first to be cooked off during the aging process. At -20°F (-29°C) the rubber phase of the binder system is absorbing the load, and thereby reducing the effects of the asphalt-extender phase of the system. This reduction in effect leads to lower increases in strength due to aging.

CONCLUSIONS

Based on the analysis presented in this paper, the following conclusions are offered.

1. Constrained specimen testing yielded approximately equal values of transition temperature, fracture temperature and peak load for both unmodified mixtures (AC5 and AC20). This could be due to the inability of the test to distinguish these properties from asphalts of the same source.
2. Constrained specimen testing indicated that mixtures using the asphalt-rubber AC5 binder produced transition and fracture temperatures approximately 10°C (18°F) lower than mixtures using the unmodified AC5.
3. Rubber particles swell during mixing due to the absorption of the lighter weight particles of the asphalt cement. This tends to leave stiffer base asphalt cements with only the heavier oils and resins. This could result in an increased binder viscosity and hence mixture stiffness. Mixtures exhibiting this increase in stiffness become very sensitive to any non-homogeneity in the mixture. This sensitivity results in increased testing variability due to the random and not always uniform distribution of the rubber particles in the binder system.
4. Softer base asphalts should be used in rubber modified systems for low temperature thermal cracking applications. Preferably one that will provide enough light ends to leave a percentage of them in the asphalt cement phase of the binder system.
5. Indirect tension testing indicated that rubber modified mixtures will exhibit more deformation at colder temperatures (i.e. 0°F and -20°F) while maintaining strengths similar to unmodified mixtures.
6. Cut beam specimens, in particular those containing a relatively soft base asphalt, will tend to crumble at the elevated temperatures used in the NCHRP AAMAS accelerated aging process. It should be noted that these problems were not encountered with the briquette specimens.
7. The addition of rubber to mixtures using AC5 did not change the tensile strength characteristics of the mixture with aging. Both mixtures exhibited approximately a twenty five percent increase in indirect tensile strength after aging. However, it should be noted that the aged AC5R mixture tensile strength was slightly less than the unaged AC5 mixture.

ACKNOWLEDGEMENTS

The authors would like to thank the Asphalt Rubber Producers Group, the U.S. Army Corps of Engineers and their Construction Productivity Advancement Research Program, the University of Arizona and Crafcro Inc., for their support and cooperation in this research program.

BIBLIOGRAPHY

1. Vinson, T.S., Janoo, V.C., Haas, R.C.G., "Summary Report: Low Temperature and Thermal Fatigue Cracking", SHRP Report Number A/IR-90-001.
2. Hills, J.F., Brien, D., "The Fracture of Bitumens and Asphalt Mixes by Temperature Induced Stresses", 1966, AAPT, Volume 35, 292-309.
3. Monismith, C.L., Secor, G.A., Secor, K.E., "Temperature Induced Stresses and Deformations in Asphalt Concrete", 1965, AAPT Volume 34, 248-285.
4. Humphreys, J., Martin, C., "Determination of Transient Thermal Stresses in a Slab with Temperature-Dependent Viscoelastic Properties", 1963, Transactions of the Society of Rheology, Volume 7.
5. Haas, R., Topper, T., "Thermal Fracture Phenomena in Bituminous Surfaces", 1969, Special Report No. 101, Highway Research Board, Washington D.C.
6. Haas, R., "A Method for Designing Asphalt Pavements to Minimize Low Temperature Shrinkage Cracking", 1973, RR-73-1, Asphalt Institute.
7. Christison, J.T., Anderson, K., "The Response of Asphalt Pavements to Low-Temperature Climatic Environments", 1972, Proceedings, Third International Conference on the Structural Design of Pavements, London, England.
8. Burgess, R., Kopvillem, O., Young, F., "Ste. Anne Test Road: Relationship Between Predicted Fracture Temperatures and Low-Temperature Field Performance", 1971, AAPT Volume 40, 148-193.
9. Arkana Test Road, Haas, R., 1970.
10. Haas, R., Phang, W., "Relationships Between Mix Characteristics and Low-Temperature Pavement Cracking", 1988, AAPT Volume 57, 198-245.
11. Finn, F., Saraf, C.L., Kulkarni, R, Nair, K., Smith, W., Abdullah, A., "Development of
12. Busby, E.O., Rader, L.F., "Flexural Stiffness Properties of Asphalt Concrete at Low Temperatures", 1972, AAPT Volume 41, 163-187.
13. Fabb, T.R.J., "The Influence of Mix Composition, Binder Properties and Cooling Rate on Asphalt Cracking at Low Temperature", 1974, AAPT Volume 43, 285-331.

14. Sugawara, T., Moriyoshi, A., " Thermal Fracture of Bituminous Mixtures", 1984, Proc, Paving in Cold Areas Mini-Workshop, 291-320.
15. Arand, W., "Influence of Bitumen Hardness on the Fatigue Behavior of Asphalt Pavements of Different Thickness Due to Bearing Capacity of Subbase, Traffic Loading, and Temperature", 1987, Proc., 6th International Conference on Structural Behavior of Asphalt Pavements, University of Michigan, 65-71.
16. Bloy, L.A.K., "Asphalt Rheology for Prediction of Low-Temperatures Behavior of Asphalt Concrete Pavements", M.S.C.E. Thesis, University of Florida, 1980.
17. Von Quintus, H.L., Scherocman, J.A., Hughes, C.S., Kennedy, T.W., "Procedural Manual for Mixture Design and AAMAS - Volume I", NCHRP Report No. 9-6(1), May 1990.
18. Stroup-Gardiner, M., Krutz, N.C., Epps, J.A., "Comparison of Mix Design Methods for Rubberized Asphalt Concrete Mixtures", Proceedings of the Asphalt Rubber Producers Group, October 1989.
19. Krutz, N.C., Stroup-Gardiner, M., "Permanent Deformation Characteristics of Recycled Tire Rubber Modified and Unmodified Asphalt Concrete Mixtures", submitted to TRB August 1991, for presentation and publication.
20. ASTM "Road and Paving Materials; Traveled Surface Characteristics", 1990 Edition.

Table 1: Test Matrix for Estimating Thermal Cracking of Modified and Unmodified Mixtures

	Binder	AC5 Ext. Oil		AC5		AC20	
	Modifier	Original	Rubber Added	Original	Rubber Added	Original	Rubber Added
CS open spec tirm aine d	Drop at 10°C/hr		XY	XY	XY	X	X
IT ndis rieo cnc t	34°F		XY	X	X	X	X
	0°F		XY	XY	XY	XY	XY
	-20°F		XY	X	X	X	X
DT irne scit on	-20°F		X	X	X	X	X

Total of 99 samples (X=3 samples tested unaged, y=3 samples tested after NCHRP AAMAS aging)

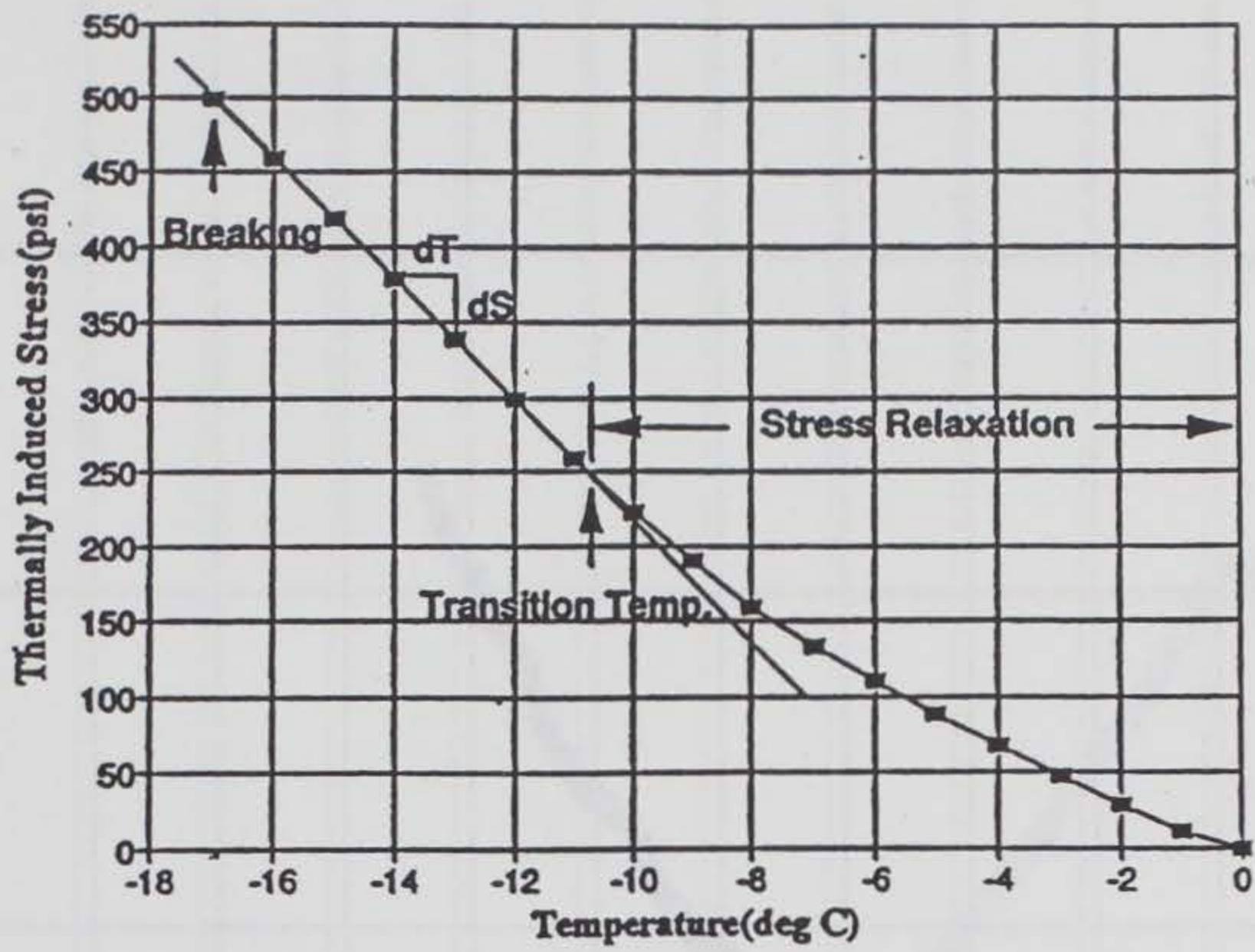

Figure 1: Thermally Induced Stress versus Temperature Relationship for Typical Asphalt Concrete Mixtures

(After Monismith et al, 1991)

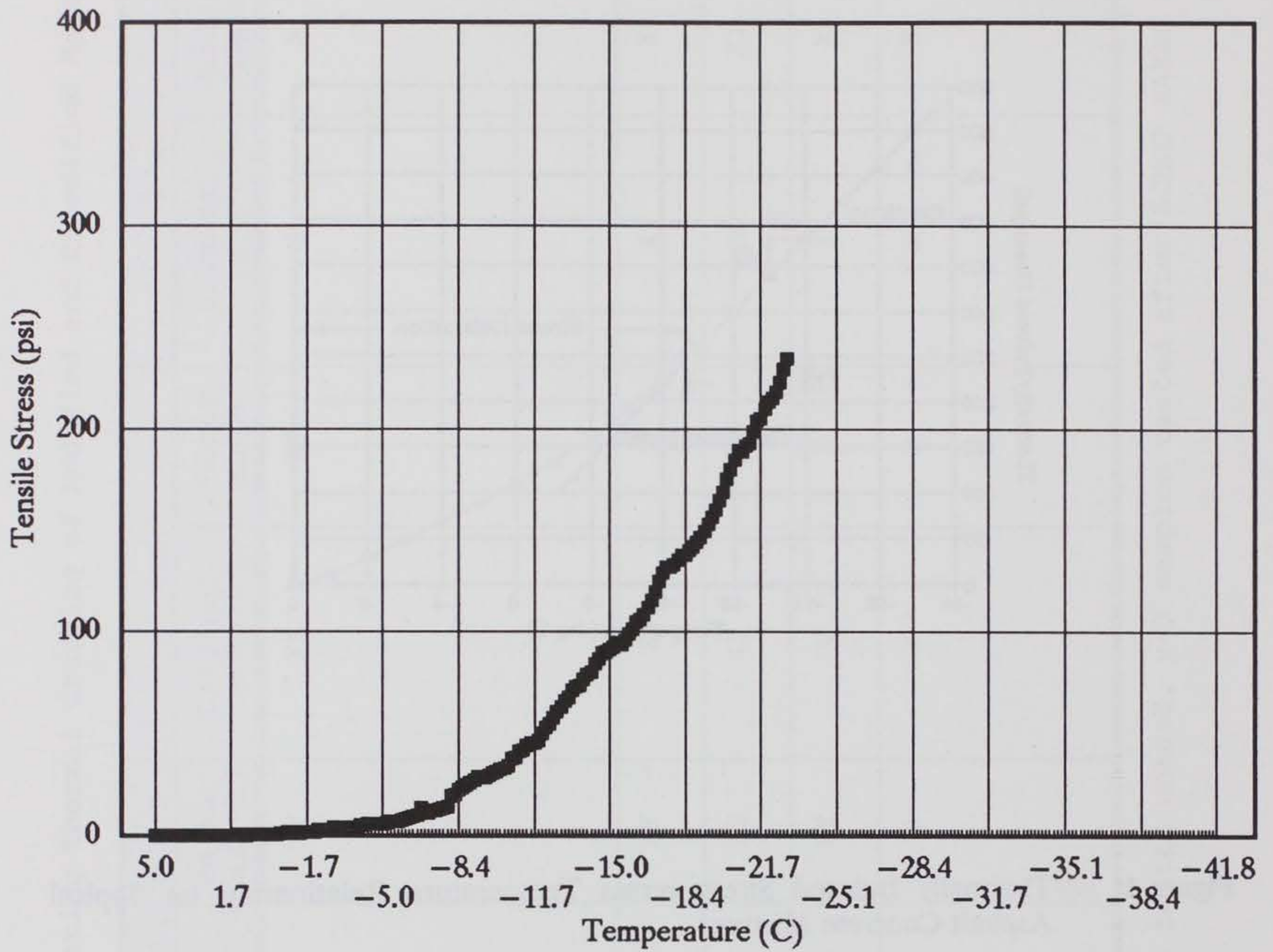

Figure 2: Average Induced Tensile Stress versus Temperature Relationship for AC5 Constrained Specimens

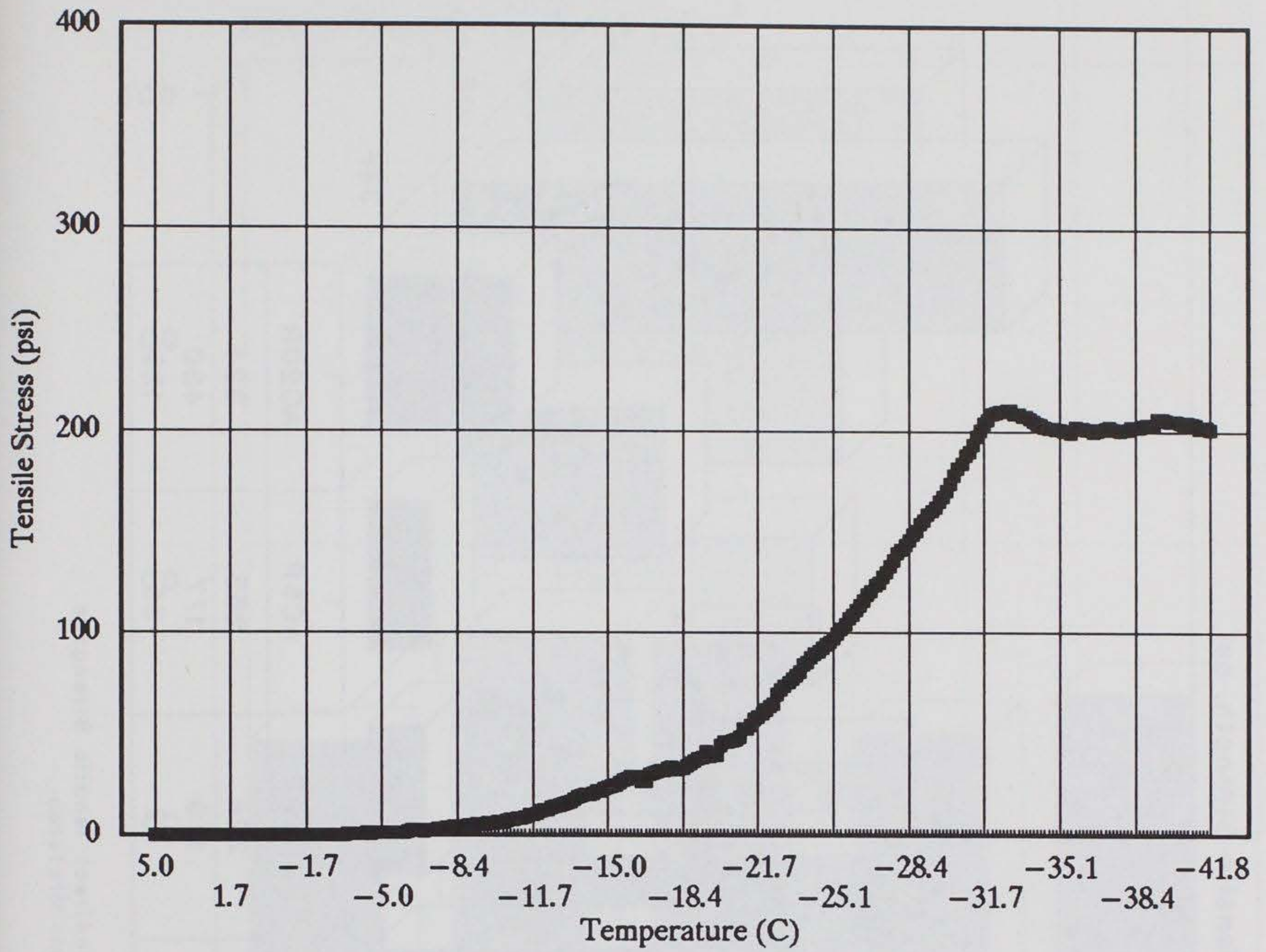

Figure 3: Average Induced Tensile Stress versus Temperature Relationship for AC5R Constrained Specimens

Indirect Tensile Strength, psi

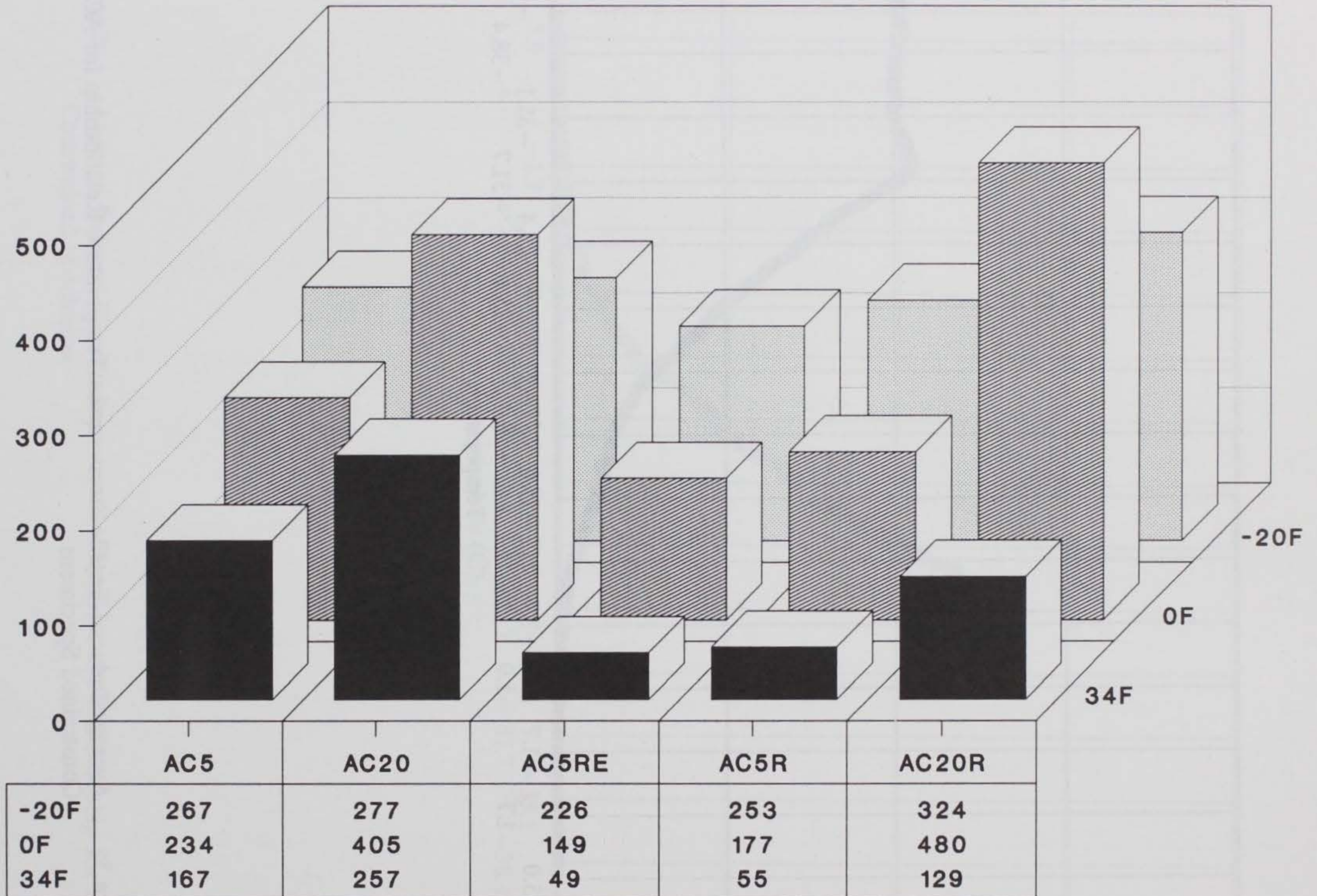

Figure 4: Comparison of Average Indirect Tensile Strengths at all Temperatures for all Mixtures

Direct Tensile Strength, psi

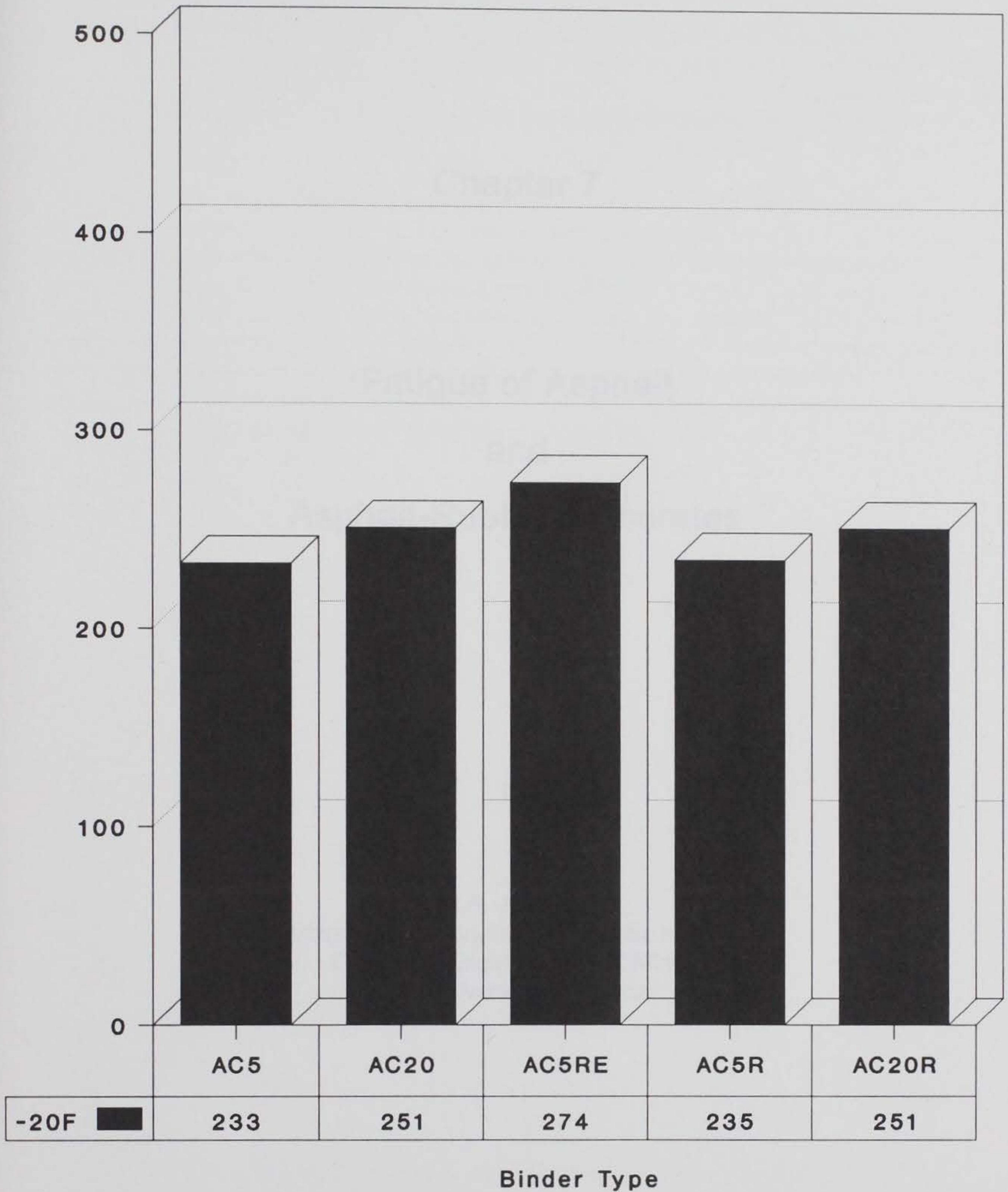

Figure 5: Average Direct Tensile Strength at -20F for all Mixtures

Chapter 7

Fatigue of Asphalt and Asphalt-Rubber Concretes

by

R.A. Jimenez
Arizona Transportation and Traffic Institute
College of Engineering and Mines
The University of Arizona

Flexure fatigue tests were performed on paving mixtures of asphalt and also asphalt-rubber. The aggregate type and gradation were selected by the researchers at the University of Nevada, Reno (UNR) and the binder contents were established by both UNR and the Waterways Experiment Station of the Corps of Engineers (WES).

The work that was planned for the fatigue testing followed a factorial program as indicated below:

- | | |
|----------------|--|
| a. Mixture | 4 level (AC-5, AC-5R, AC-5RE, and AC-20) |
| b. Stress | 3 levels |
| c. Temperature | 3 levels |
| d. Replicate | 3 levels |

Fatigue stressing was given with a device called a "deflectometer". The deflectometer consisted of two units. One applied forces whose magnitudes and frequencies could be made to vary in a sinusoidal fashion. The other, a reaction unit, held a 17.5-inch diameter specimen about its periphery and gave the specimen a support pressure of uniform value about the bottom surface. The specimen was loaded over a circular central area on the top surface. Loading was continued until gages gave indication that cracks had developed on the central bottom portion of the specimen. Figure 1 shows a schematic of the deflectometer test set-up.

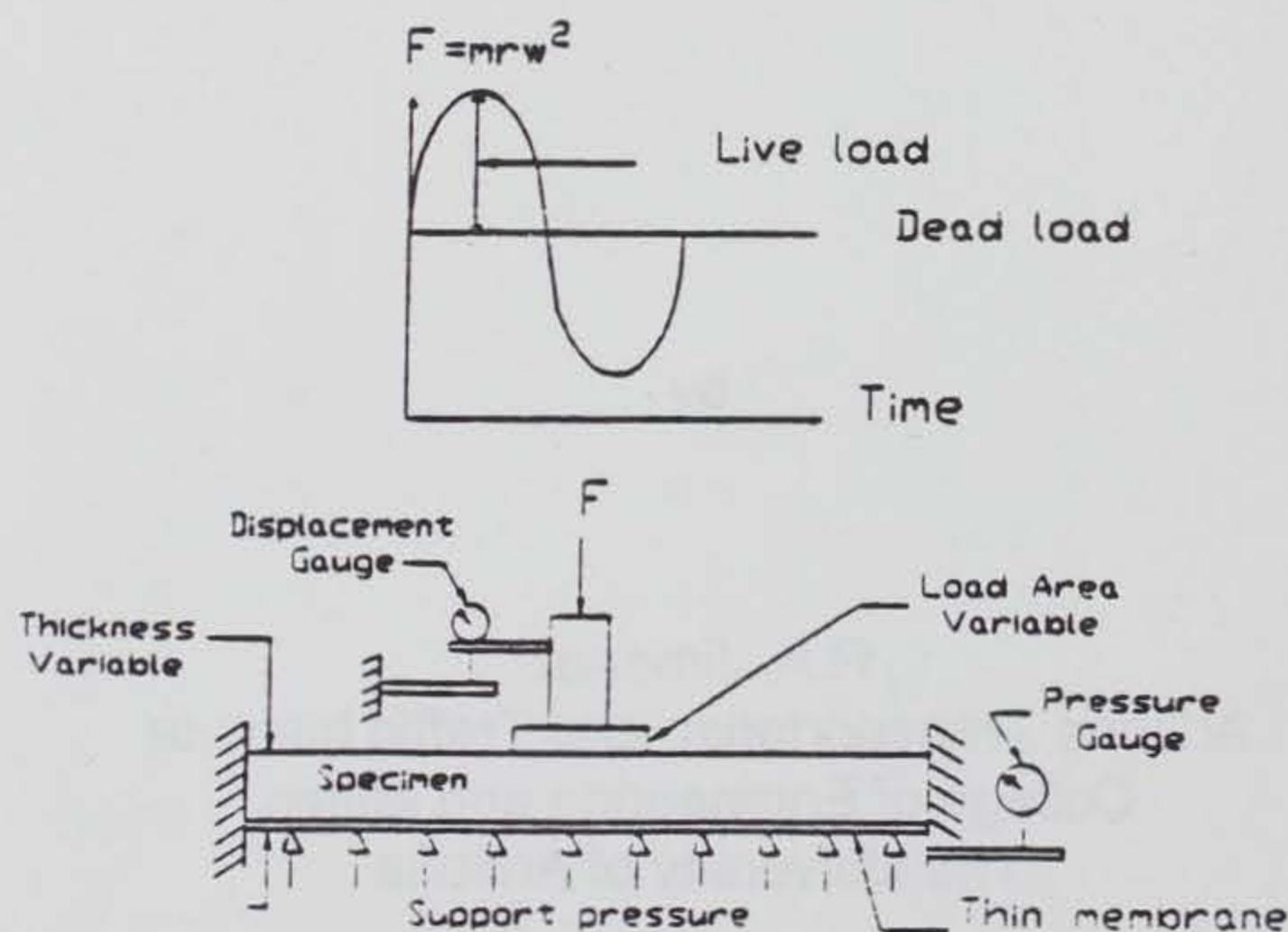

Figure 1. Schematic of the Deflectometer and Its Loading.

Results of the testing program indicated that within the range of stresses applied; the following was found:

- a. at equivalent stress the asphalt-rubber mixtures had a lower fatigue life than for the asphalt ones,
- b. the fatigue curves for the asphalt-rubber mixtures at 40°F were similar to the fatigue curve at 77°F for the AC-5 mixture; a somewhat similar comparison can be made for temperatures of 23°F for asphalt-rubber and 40°F for AC-5 (Figure 2).
- c. the crack patterns developed for the asphalt only mixtures were that of alligating; however, the ones for the asphalt-rubber were not of the alligating type but of the type that have corresponded to over-asphalted mixtures.

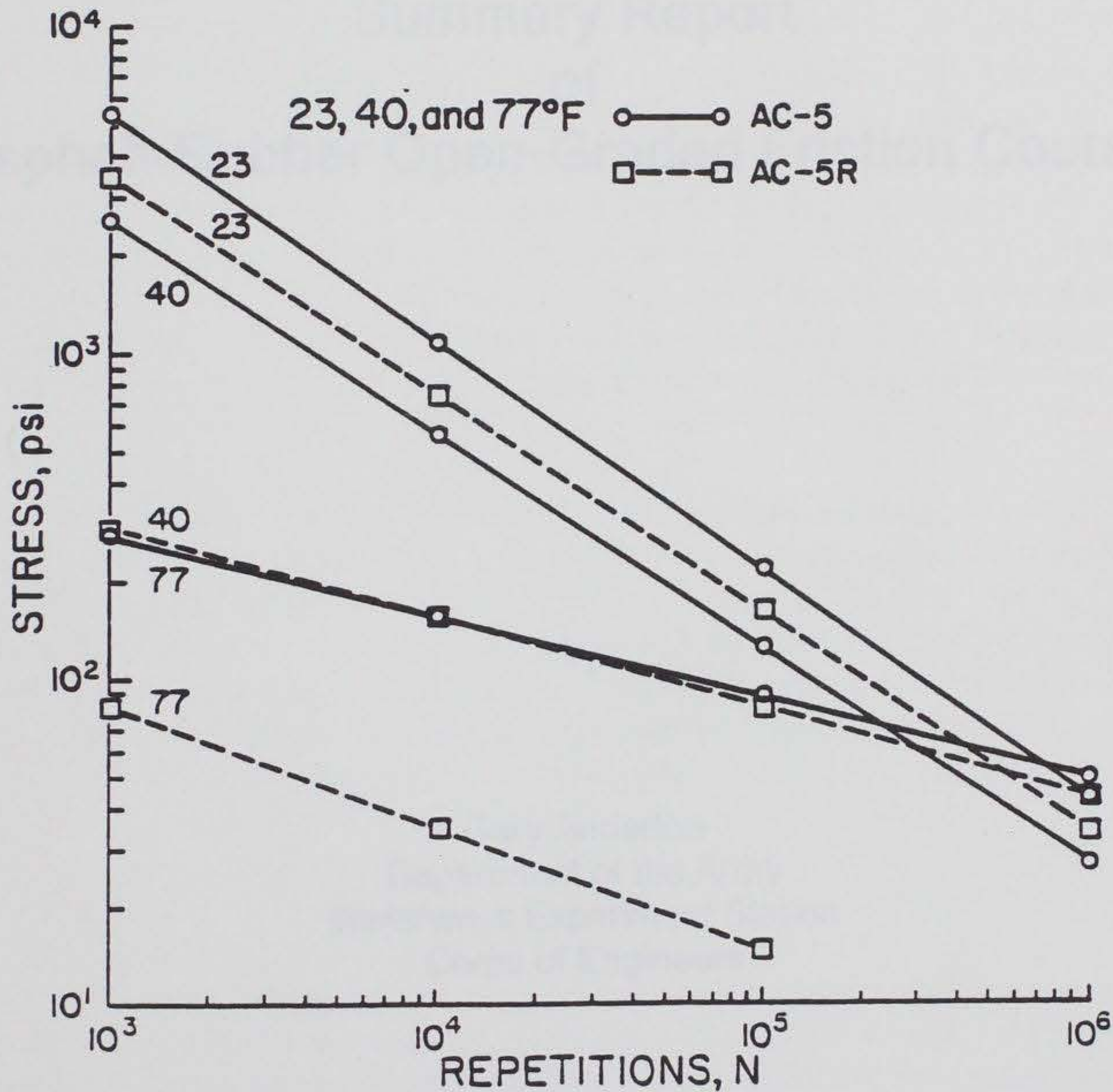

Figure 2. Fatigue Curves for Various Temperatures for AC-5 and AC-5R.

The main conclusions made are as follows:

1. The present method of the deflectometer test may have to be modified for asphalt-rubber mixtures.
2. The fatigue curves for the asphalt-rubber mixtures were less temperature susceptible than those for the asphalt only mixtures.
3. The crack pattern found for the asphalt-rubber specimens indicated the mixtures had a too high binder content. A better fatigue characteristic would have been found at a lower binder content.



Chapter 8

Summary Report of Asphalt-Rubber Open-Graded Friction Courses

by

**Gary Anderton
Department of the Army
Waterways Experiment Station
Corps of Engineers**

ASPHALT-RUBBER OPEN-GRADED FRICTION COURSE

BACKGROUND

An open-graded friction course (OGFC) is a relatively thin asphaltic pavement surfacing containing approximately 20 to 30 percent air voids. A properly functioning OGFC will absorb rain water and provide a drainage layer for this water to be carried out to the pavement shoulder. This function significantly enhances user safety by eliminating automobile hydroplaning and increasing overall wet weather traction. When the pavement is dry, the internal air voids absorb a significant amount of road noise caused by the tire/pavement contact, which reduces noise pollution in areas surrounding heavily trafficked pavements. Besides providing these and other benefits, a typical OGFC is a relatively inexpensive surfacing material in comparison with other asphaltic materials.

The use of open-graded friction courses has never been widespread in the United States because of its reputed lack of durability. A considerable amount of premature failures have occurred in OGFC field applications throughout the years to support this reputation (3,4). In most instances, these failures have involved raveling, stripping and/or various types of cracking. Not only are most of the failures involving OGFC's premature, but they tend to accelerate rapidly, requiring immediate maintenance or complete removal. When designed and constructed properly, an OGFC delivers significant benefits to the pavement user. When designed or constructed improperly, the consequences can be catastrophic.

In a typical dense-graded asphalt concrete system, there exists a proportionate amount of fine aggregates which provide structural support to the load bearing larger stones of the mix. There are very few of these fine aggregates in the typical open-graded friction course gradation. Due to the lack of fine aggregates, the binder plays a more important role in keeping the mixture intact. Therefore, the effects of a poor binder are much more detrimental to a OGFC than to a typical dense-graded asphalt mixture. Likewise, the key to a better OGFC many times lies in using a better binder.

Because of the open void structure, the OGFC binder is exposed to harmful effects of the environment throughout the thickness of the OGFC layer. Exposure to direct oxidation, water stripping and freeze-thaw cycles are problems associated with OGFC binders. These conditions lead to weathered, brittle binders which cause the OGFC to rapidly deteriorate. A thicker film of binder on the aggregates is an obvious approach to combat many of these hazards, but this approach is limited by the associated problems of excess binder drain off during construction which closes the void structure and reduces the water draining capabilities of the OGFC.

Asphalt-rubber binders have several material properties which make them attractive for OGFC applications. Asphalt-rubber remains highly viscous in the typical OGFC mix temperature range and therefore should allow a thicker film of binder without detrimental binder drain off problems. Asphalt-rubber is more elastic at low temperatures in comparison with traditional asphalt cements and therefore should be less susceptible to low temperature cracking and freeze-thaw damage. Asphalt-rubber binders are more oxidation resistant because of the antioxidants and carbon black materials in the rubber. Finally, the use of asphalt-rubber binders is attractive from an environmental standpoint since it uses a waste product (discarded automobile and truck tires) as a raw material.

OBJECTIVE

The objective of this research was to determine the potential benefits of asphalt-rubber binders when used in open-graded friction courses and to recommend the asphalt-rubber types and mix design procedure required to achieve optimum field performance.

SCOPE

Standard OGFC mix designs were conducted using varying binder contents and mix temperatures. An analysis of the effects of these mix design variables on the resulting voids criteria was used to determine the proper mix design procedure for asphalt-rubber OGFC mixtures. Additional tests conducted on the varying types of OGFC mixtures included:

- Binder Drain Off Tests
- Permeability Tests
- Stripping (Water Sensitivity) Tests
 - ASTM Soak Test
 - Texas Boiling Test
 - Porewater Pressure Debonding Test

TEST METHODS

A number of open-graded mixture tests were conducted during this study. A single aggregate source and gradation were used in order to isolate the binder effects. Laboratory tests for evaluating open-graded asphalt mixtures are not very common and a great deal of research into the literature was necessary to find a group of tests suitable for this study.

Mix Designs

The most common approach in designing open-graded asphalt mixtures is to estimate the optimum binder content by conducting the Centrifuge Kerosene Equivalency (CKE) test on the proposed job aggregate. The Federal Highway Administration (5) and the U.S. Army Corps of Engineers (6) both recommend this design procedure in their respective current OGFC mix design guidance. The CKE test is described by Test Method California No. 303-F and is a measure of the test aggregate's surface area and absorption.

The binder content derived from this test along with an aggregate source and gradation with a suitable performance history are historically the only two open-graded mixture design criteria used.

Some open-graded mixture researchers have claimed that binder contents much higher than the CKE derived values are allowable with asphalt-rubber binders (7,8,3). To validate this claim and to determine the limits of higher binder contents, a series of mix designs was conducted for each test binder. Six inch diameter by two inch thick specimens were compacted with the Marshall hand hammer compactor using 25 blows on one side of the specimen. This compactive effort has been found to correlate with field densities of normally constructed open-graded mixtures (9,10). The resulting open-graded mixture specimens were weighed in air and in water to determine physical properties such as void content and density. Changes in these physical properties in relation to the binder type and binder content were used to determine the proper mix design method for open-graded mixtures containing asphalt-rubber.

Binder Drain Off

When open-graded asphalt mixtures are produced at the plant, excess mix temperatures or binder contents can cause the binder to drain off of the mixture while in the haul trucks. This causes serious problems at the job site since some of the mixture will be undercoated with binder while other areas will be oversaturated with binder, depending on whether the mixture came from the top or bottom of the haul truck. These potential problems can be difficult to control when using normal asphalt cements since the optimum mixing temperature and binder contents are usually not far below the levels which cause excess binder drainage problems. To address this problem, laboratory binder drain off tests were conducted under various conditions of temperature and binder content.

The binder drain off test was devised during past research studies at WES (10). The test method begins by preparing a 300 gram sample of the open-graded mixture for each binder content. The samples are mixed and tested at the same selected temperature. Once the binder and aggregates are mixed thoroughly, each sample is spread evenly over the center area (approximately 6 inches in diameter) of a 1 foot square glass plate. Each sample plate is properly labeled and placed in an oven preheated to the appropriate test temperature. The samples are removed from the oven after two hours and allowed to cool to room temperature. Once cooled, the amount of drainage to the bottom of the glass plate is observed to determine the percentage of the 6-inch diameter center area covered with drained binder. This visually determined percent drainage value (in increments of 10 percent) is recorded as the test result. During the WES research study previously mentioned (10), White used field evaluations of 17 OGFC pavements and an extensive laboratory study to determine that 50 percent drainage by this test is a reasonable limit to prevent detrimental binder drainage during mixing and construction.

Permeability

A laboratory permeability test, which was devised during previous research at WES on porous friction courses (10), was conducted on open-graded mixture samples containing the various test binders. The test involves a time measurement of the flow rate for a known volume of water to pass through a representative sample of compacted, open-graded mixture. The test sample consists of 6 inch diameter specimens made of approximately 2 inch thick compacted dense-graded asphalt mixture topped with a 3/4 inch thick OGFC layer. The dense-graded mixture is compacted first and merely acts as a base for the OGFC layer. The OGFC layer is compacted on top of the dense-graded base using 10 blows of the Marshall hand hammer, resulting in a thickness and density representative of typical field conditions.

A 4 inch diameter clear plastic standpipe is used to hold a measurable head of water on top of the test samples. Before testing, a rubber O-ring is placed between the standpipe and the surface of the sample. A 100 pound surcharge load is applied to the standpipe to restrict surface drainage and to force most of the water to flow into the 3/4 inch OGFC layer. Once the standpipe has been positioned and loaded, water is introduced by pump into the standpipe to a level above the 10 inch mark on the side of the standpipe. Addition of water is then stopped, and the time to fall from the 10 to 5 inch level is measured with a stopwatch. This test is repeated three times and the average of the values is computed. The permeability is determined from the relation $Q = VA$. Thus, for the 5 inch falling head of this test, the permeability (Q) in milliliters per minute is equal to 15,436.8 divided by the time to fall in seconds. Higher permeability values reflect a more effective PFC in wet weather conditions. A reasonable lower limit of permeability for newly constructed OGFC pavements is 1000 ml/min.

Stripping

To complete the open-graded mixture laboratory analysis, three different stripping tests were conducted on each test binder. Stripping relates to the separation of binder and aggregate in the presence of water, and this phenomenon is one of the main causes of open-graded friction course pavement failure. The three tests used in this study were the ASTM D1664 "Standard Test Method for Coating and Stripping of Bitumen-Aggregate Mixtures" (2), the Texas Boiling Test, and the Porewater Pressure Debonding Test.

The ASTM D1664 stripping test is generally used to measure the compatibility between the binder and the aggregate in the presence of water, and is known to identify only those mixtures with extremely serious stripping potential. The test procedure begins with coating a representative 100 gram sample of aggregates with the binder at the mix temperature appropriate for the given binder. After coating, the mixture is allowed to cool to room temperature. The coated aggregate is then transferred to a 600-ml glass container and immediately covered with approximately 400-ml of distilled water at room temperature. The coated aggregate remains immersed in the water for 16 to 18 hours. After this time, the water covered specimen is illuminated by a shaded lamp and a visual determination of the aggregate surface area which remains coated is made. The test

result is recorded as either pass (above 95% binder retention) or fail (below 95% binder retention).

The Texas Boiling Test was conducted on each of the six test binders as an additional stripping test. The Texas Boiling Test measures stripping potential of an asphalt-aggregate mixture in a manner similar to the ASTM method, except that the sample is soaked in boiling water. The test method is described in detail in the literature (11), but can be summarized as follows: A 300 gram sample of representative aggregates is coated with the appropriate amount of binder at the appropriate mix temperature. The resulting mixture is transferred to a piece of aluminum foil and allowed to cool to room temperature for two hours. Once cooled, the mixture is added to a 1000 ml beaker containing 500 ml of boiling distilled water. The water is maintained at a medium boil for 10 minutes, and the mixture is stirred with a glass rod during this time. During and after boiling, any stripping binder is removed from the water by skimming with a paper towel. After 10 minutes of boiling, the beaker is removed from the heat source and allowed to cool to room temperature. The water is then drained from the beaker and the wet mix is emptied onto a paper towel to dry. After drying for one day, the percentage of binder retained after boiling is visually determined and this percent retention value is recorded as the test result.

The final stripping test conducted on the open-graded test mixtures was the Porewater Pressure Debonding Test. This test was developed at the University of Arizona by Dr. Rudy A. Jiminez, and is described in at least two literature references (12,13). The laboratory equipment is used to simulate the cycles of porewater pressure imposed on OGFC pavements by traffic tires when the OGFC is saturated with water and certain conditions exist within the pore structure. At least a small percentage of OGFC pore spaces are isolated enough from other pore spaces to develop pore pressures in the right conditions. The number of isolated pore spaces is known to increase when accumulations of the tire rubber dust, silts, deicing materials, or other contaminants settle into the pore spaces of an OGFC over time.

The Porewater Pressure Debonding Test method involves exposing the test samples to repeated cycles of porewater pressure and then measuring the tensile strength of these samples. These strength values are used with the strength values of control samples which do not undergo porewater pressure exposure to obtain a percent retained strength. Higher percent retained strength values indicate that a given binder and open-graded mixture is less sensitive to degradation damage resulting from traffic in wet conditions.

For Porewater Pressure testing, six inch diameter by 2 inch thick specimens of open-graded mixtures were first compacted to meet the optimum density and void conditions determined previously in the mix design tests. Three of the specimens are placed on a 3-shelf carriage which is then placed into a stressing chamber. The chamber is filled with 122°F water and the specimens are allowed to soak in this condition for 40 minutes. At this time, 20 inches of mercury vacuum is pulled on the stressing chamber and held for five minutes in order to completely saturate the specimens. After five minutes of vacuum pressure, the vacuum is released and more hot water is added to

displace all air from the stressing chamber. Next, 1000 cycles of water pressures varying from 5 to 30 psi are applied to the chamber, which takes approximately 10 minutes to complete. The water is then drained from the chamber and the specimens are removed. The specimens are cooled at ambient temperature for 10 minutes and then placed in a 77°F water bath for one hour. Finally, the sample is removed from the water bath and the "wet strength" of the sample is obtained using a built-in double punch tensile test. This same tensile strength test is used to obtain the "dry strength" of three control specimens which are conditioned by sealing them in plastic bags and placing them in the same 77°F water bath for one hour. The wet strength is divided by the dry strength and the ratio is expressed as a percent retained strength.

SUMMARY OF TEST RESULTS

The tests conducted to determine optimum binder contents resulted in a 6.6 percent optimum for the asphalt cement samples and an 8.0 percent optimum for the asphalt-rubber samples. The results of the mix design analysis are listed in Table 3. These results indicated that asphalt-rubber binders provide higher void contents (thus higher water carrying capacities), even at higher binder contents. These tests also indicated that the field densities may be higher for asphalt-rubber open-graded friction courses.

TABLE 3

OPEN-GRADED MIX DESIGN DATA

Binder	Binder Content (%)	Total Voids (%)	Voids Filled (%)	Unit Weight (pcf)
AC-5	6.6	22.0	43.6	119.0
	7.6	20.8	45.4	116.7
	8.6	17.2	50.3	113.6
AC-20	6.6	24.9	36.7	115.2
	7.6	22.2	42.1	117.1
	8.6	19.3	46.8	120.4
AC-40	6.6	26.2	32.0	115.6
	7.6	22.9	36.2	118.2
	8.6	20.0	43.5	120.9
AC-5RE	6.6	26.0	31.8	115.2
	7.6	24.5	36.2	117.8
	8.6	23.8	39.3	120.3
AC-5R	6.6	26.3	31.2	117.1
	7.6	25.7	32.2	119.2
	8.6	25.0	36.4	121.8
AC-20R	6.6	27.3	30.0	117.5
	7.6	26.9	30.9	119.8
	8.6	26.0	31.7	122.8

The binder drain off test results (Table 4) identified a significant advantage offered by asphalt-rubber binders in that they are much less susceptible to detrimental binder drainage, even at higher mixing temperatures. The permeability test results (Table 5) supported the indications of the voids measurements made in the mix design analysis as the asphalt-rubber samples had substantially higher permeabilities.

The results of the three stripping tests are listed in Table 6. The first stripping test, which was specified by ASTM, merely confirmed that the aggregates being used did not have a serious stripping potential. The second stripping test, known as the Texas Boiling Test, indicated slight to moderate improvements in stripping resistance for the asphalt-rubber binders. The final stripping test, known as the Porewater Pressure Debonding Test, indicated that the two asphalt-rubber binders without extender oil provided outstanding resistance to the stripping effects of porewater pressures. The asphalt-rubber binder with extender oil rated moderately lower along with the other test samples in this stripping test.

TABLE 4
BINDER DRAIN OFF TEST RESULTS

Binder	Percent Binder	Percent Drainage			
		250°F	275°F	300°F	325°F
AC-5	6.6	10	30	70	
	7.6	60	60	80	
	8.6	70	80	90	
AC-20	6.6	20	30	30	
	7.6	50	50	50	
	8.6	70	70	80	
AC-40	6.6	30	40	50	
	7.6	50	50	60	
	8.6	60	60	80	
AC-5RE	6.6		10	10	10
	7.6		10	10	10
	8.6		20	20	20
	8.0			10	20
	9.0			10	20
	10.0			20	40
AC-5R	6.6		0	10	10
	7.6		0	10	10
	8.6		0	20	20
	8.0			10	20
	9.0			10	30
	10.0			10	30
AC-20R	6.6			0	10
	7.6			0	10
	8.6			0	30
	8.0			10	10
	9.0			10	10
	10.0			30	30

TABLE 5
PERMEABILITY TEST RESULTS

PERCENT BINDER	PERMEABILITY BINDER	(mL/min)
AC-5	6.6	4540
	7.6	3356
	8.6	3284
AC-20	6.6	5717
	7.6	3284
	8.6	2490
AC-40	6.6	7017
	7.6	6712
	8.6	5323
AC-5RE	8.0	4980
	9.0	3958
	10.0	3958
AC-5R	8.0	7017
	9.0	5937
	10.0	5146
AC-20R	8.0	7351
	9.0	6712
	10.0	6432

TABLE 6
STRIPPING TEST RESULTS

BINDER	ASTM (95% Binder Retention)	TEXAS BOILING (% Binder Retention)	POREWATER PRESS. (% Tensile Str. Retention)
AC-5	PASS	60	89
AC-20	PASS	70	79
AC-40	PASS	70	85
AC-5RE	PASS	75	85
AC-5R	PASS	80	98
AC-20R	PASS	90	99

CONCLUSIONS

1. The current method of determining optimum binder contents for open-graded friction courses was modified to allow for higher binder contents when using asphalt-rubber binders. This modified method resulted in an optimum binder content for the asphalt-rubber mixtures which was 1.4 percent higher than the optimum derived for the asphalt cement binders. Both of these optimum binder contents were verified by the remaining mix tests.
2. Open-graded mixture samples made with asphalt-rubber binders had void contents about 3 to 8 percent higher than their asphalt cement counterparts, depending upon the binder content used. The percent voids filled with binder was reduced and the unit weight was increased by the addition of reclaimed rubber in open-graded asphalt mixtures.
3. Binder drainage at typical asphalt plant mixing temperatures was significantly reduced by the addition of reclaimed rubber to the asphalt cement. This means that asphalt-rubber porous friction course mixtures can be produced at higher temperatures, thereby allowing construction to occur in colder climates.
4. The permeability of an open-graded friction course is increased when using asphalt-rubber binders, making the asphalt-rubber open-graded friction course more effective in draining rainwater.
5. Stripping of the binder from aggregates caused by the presence of water and porewater pressures was reduced for the asphalt-rubber test samples. One of the stripping tests indicated that the AC-5RE binder did not enhance stripping resistance, however.
6. All laboratory test results indicated that asphalt-rubber open-graded friction courses would be more durable, longer lasting, and better water draining pavement layers when compared with unmodified asphalt cement open-graded friction courses. These pavement performance improvements are due to the inherent physical and chemical properties of the asphalt-rubber binders and to the fact that a thicker binder film thickness on the aggregate can be achieved with the asphalt-rubber. The addition of extender oil to the AC-5 asphalt and rubber blend seemed to detrimentally affect some of the test results, however.

RECOMMENDATIONS

Based on the conclusions derived from the results of this laboratory study, the following recommendations are made:

1. Asphalt-rubber binders should be used in open-graded friction courses to achieve any or all of the following pavement performance improvements:
 - a. Increased permeability for improved water draining capabilities
 - b. Reduced binder drainage at high plant mixing and hauling temperatures
 - c. Reduced stripping potential
2. The generalized mix design method found in the Appendix of the Volume II Technical Report related to this study should be used when designing asphalt-rubber open-graded friction courses in the future.

REFERENCES

1. Roberts, F. L., Kandahal, P. S., Brown, E. R., and Dunning, R. L. (1989, August). "Investigation and Evaluation of Ground Tire Rubber in Hot Mix Asphalt," National Center for Asphalt Technology, Auburn, AL.
2. American Society of Testing and Materials. 1991. 1991 Annual Book of ASTM Standards, Vol 04.03, Philadelphia, PA.
3. Shuler, T. S. (1988, December). "Improving Durability of Open-Graded Friction Courses," Research Report 79301-1F, New Mexico Engineering Research Institute, Albuquerque, NM.
4. White, T. D. (1976, April). "Field Performance of Porous Friction Surface Course," Miscellaneous Paper S-76-13, U.S. Army Engineer Waterways Experiment Station, Vicksburg, MS.
5. Federal Highway Administration. (1974). "Open-Graded Friction Course Mixture Design," FHWA RD-74-2, McLean, VA.
6. Headquarters, Department of the Army. (1984, September). "Porous Friction Course For Airfields and Roads," Guide Specification CEGS-02562, Washington, DC.
7. Page, G. E. (1989, September). "Florida's Initial Experience Utilizing Ground Tire Rubber in Asphalt Concrete Mixes," Research Report FL/DOT/MO 89-366, Florida Department of Transportation, Gainesville, FL.
8. Ruth, B. E. (1989, November). "Evaluation of Experimental Asphalt-Rubber, Open Graded, Friction Course Mixtures: Materials and Construction of Test Pavements on State Road 16," Florida Department of Transportation, Gainesville, FL.
9. Ahlrich, R. C. and Anderton, G. L. (1991, January). "Construction and Evaluation of Resin Modified Pavement," Technical Report GL-91-13, U.S. Army Engineer Waterways Experiment Station, Vicksburg, MS.
10. White, T. D. (1975, February). "Porous Friction Surface Course," Miscellaneous Paper S-75-12, U.S. Army Engineer Waterways Experiment Station, Vicksburg, MS.
11. Kennedy, T. W., Roberts, F. L., and Kang, W. L. (1984, January). "Evaluating Moisture Susceptibility of Asphalt Mixtures Using the Texas Boiling Test," Record No. 968, Transportation Research Board, Washington, DC.

12. Jiminez, R. A. (1974, January). "Testing for Debonding of Asphalt from Aggregates," Record No. 515, Transportation Research Board, Washington, DC.
13. _____ (1989, January). "Field Control Test for Debonding of Asphaltic Concrete," Record No. 1228, Transportation Research Board, Washington, DC.

Waterways Experiment Station Cataloging-in-Publication Data

Anderton, Gary L.

Summary of research on asphalt rubber binders and mixes / by Gary L. Anderton.

125 p. : ill. ; 28 cm. — ([Technical report] ; CPAR-GL-92-2)

Includes bibliographical references.

1. Pavements, Asphalt concrete — Additives. 2. Binders (Materials)
3. Asphalt-rubber — Testing. 4. Pavements, Asphalt — Recycling.

I. U.S. Army Engineer Waterways Experiment Station. II. Construction
Productivity Advancement Research Program. III. Title. IV. Series:
Technical report (U.S. Army Engineer Waterways Experiment Station) ;
CPAR-GL-92-2.

TA7 W34 no.CPAR-GL-92-2