

Hands

DREDGING OPERATIONS TECHNICAL  
SUPPORT PROGRAM

TECHNICAL REPORT D-84-4

CHL  
LIBRARY



US Army Corps  
of Engineers

LONG-TERM IMPACTS INDUCED BY DISPOSAL  
OF CONTAMINATED RIVER SEDIMENTS  
IN ELLIOTT BAY, SEATTLE, WASHINGTON

by

Robert N. Dexter, Dale E. Anderson, Elizabeth A. Quinlan

URS Company  
Fourth and Vine Building  
2615 Fourth Avenue  
Seattle, Washington 98121

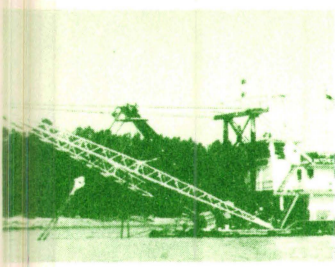

September 1984  
Final Report

Approved For Public Release; Distribution Unlimited

Prepared for DEPARTMENT OF THE ARMY  
US Army Corps of Engineers  
Washington, DC 20314

Under Contract No. DACW39-79-C-0038

Monitored by Environmental Laboratory  
US Army Engineer Waterways Experiment Station  
PO Box 631, Vicksburg, Mississippi 39180-0631



028 11

Unclassified

SECURITY CLASSIFICATION OF THIS PAGE (When Data Entered)

REPORT DOCUMENTATION PAGE		READ INSTRUCTIONS BEFORE COMPLETING FORM
1. REPORT NUMBER Technical Report D-84-4	2. GOVT ACCESSION NO.	3. RECIPIENT'S CATALOG NUMBER
4. TITLE (and Subtitle) LONG-TERM IMPACTS INDUCED BY DISPOSAL OF CONTAMINATED RIVER SEDIMENTS IN ELLIOTT BAY, SEATTLE, WASHINGTON		5. TYPE OF REPORT & PERIOD COVERED Final report
		6. PERFORMING ORG. REPORT NUMBER
7. AUTHOR(s) Robert N. Dexter, Dale E. Anderson, Elizabeth A. Quinlan		8. CONTRACT OR GRANT NUMBER(s) Contract No. DACW39-79-C-0038
9. PERFORMING ORGANIZATION NAME AND ADDRESS URS Company Fourth and Vine Building, 2615 Fourth Avenue Seattle, Washington 98121		10. PROGRAM ELEMENT, PROJECT, TASK AREA & WORK UNIT NUMBERS Dredging Operations Technical Support Program
11. CONTROLLING OFFICE NAME AND ADDRESS DEPARTMENT OF THE ARMY US Army Corps of Engineers Washington, DC 20314		12. REPORT DATE September 1984
		13. NUMBER OF PAGES 224
14. MONITORING AGENCY NAME & ADDRESS (If different from Controlling Office) US Army Engineer Waterways Experiment Station Environmental Laboratory PO Box 631, Vicksburg, Mississippi 39180-0631		15. SECURITY CLASS. (of this report) Unclassified
		15a. DECLASSIFICATION/DOWNGRADING SCHEDULE
16. DISTRIBUTION STATEMENT (of this Report)  Approved for public release; distribution unlimited.		
17. DISTRIBUTION STATEMENT (of the abstract entered in Block 20, if different from Report)		
18. SUPPLEMENTARY NOTES  Available from National Technical Information Service, 5285 Port Royal Road, Springfield, Virginia 22161.		
19. KEY WORDS (Continue on reverse side if necessary and identify by block number) Environmental impact analysis--Elliott Bay (Seattle, Wash.) (LC) Dredged material--Elliott Bay (Seattle, Wash.)--Environmental aspects (WES) Elliott Bay (Seattle, Wash.)--Environmental aspects (LC) Aquatic ecology--Elliott Bay (Seattle, Wash.) (LC) Waste disposal sites--Elliott Bay (Seattle, Wash.) (LC)		
20. ABSTRACT (Continue on reverse side if necessary and identify by block number)  Long-term trends in the physical, chemical, and biological characteristics of dredged material at a deepwater, experimental disposal site in Elliott Bay, Seattle, Washington, were studied. This site was studied previously as part of the US Army Corps of Engineers Dredged Material Research Program which determined the behavior of dredged material during disposal and characterized its impact over the following 9 months. The site was selected for additional work for a number of reasons. The dredged sediments contained high  (Continued)		

20. ABSTRACT (Continued).

concentrations of polychlorinated biphenyls (PCBs) and the benthic community did not recover to predisposal conditions during the original study.

Analysis of the data obtained during three cruises over a 1-1/2-year period, initiated 3 years after the original disposal, yielded the following conclusions:

- a. The dredged material deposit was essentially unchanged by physical processes. No evidence of significant erosion or deposition of new sediment was observed, based on bathymetric surveys and direct sediment analyses. In addition, analysis of bottom currents indicated that velocities sufficient to erode the deposit occur infrequently.
- b. The PCBs in the dredged material deposit were chemically stable, with no evidence that either diffusion or degradation was altering PCB concentrations.
- c. Benthic macrofauna at the site were observed to have completely recovered from the impacts immediately following disposal and, in fact, appeared to be present in greater abundance in the dredged material than in the surrounding sediments. This enrichment reflected a biological response to the physical characteristics of the dredged material and/or a greater abundance of detrital food at the disposal site.
- d. While not exhibiting any toxic response, the macrofauna on the dredged material were found in general to have higher concentrations of PCBs than those from the surrounding areas. The PCB levels in the organisms appeared to be directly proportional to the levels in the ambient sediments.

Results of this study provide a basis for a realistic evaluation of the environmental impacts of open-water dredged material disposal and thus assist in establishing environmentally sound management strategies for future disposal activities.

## EXECUTIVE SUMMARY

Long-term trends in the physical, chemical, and biological characteristics of dredged material at a deepwater, experimental disposal site in Elliott Bay, Seattle, Washington, were studied. This site was studied previously as part of the U.S. Army Corps of Engineers Dredged Material Research Program which determined the behavior of dredged material during disposal and characterized its impact over the following 9 months. The site was selected for additional work for a number of reasons. The dredged sediments contained high concentrations of polychlorinated biphenyls (PCBs) and the benthic community did not recover to predisposal conditions during the original study.

Analysis of the data obtained during three cruises over a 1-1/2-year period, initiated 3 years after the original disposal, yielded the following conclusions:

- A. The dredged material deposit was essentially unchanged by physical processes. No evidence of significant erosion or deposition of new sediment was observed, based on bathymetric surveys and direct sediment analyses. In addition, analysis of bottom currents indicated that velocities sufficient to erode the deposit occur infrequently.
- B. The PCBs in the dredged material deposit were chemically stable, with no evidence that either diffusion or degradation was altering PCB concentrations.
- C. Benthic macrofauna at the site were observed to have completely recovered from the impacts immediately following disposal and, in fact, appeared to be present in greater abundance in the dredged material than in the surrounding sediments. This enrichment reflected a biological response to the physical characteristics of the dredged material and/or a greater abundance of detrital food at the disposal site.
- D. While not exhibiting any toxic response, the macrofauna on the dredged material were found in general to have higher concentrations of PCBs than those from the surrounding areas. The PCB levels in the organisms appeared to be directly proportional to the levels in the ambient sediments.

Results of this study provide a basis for a realistic evaluation of the environmental impacts of open-water dredged material disposal and thus assist in establishing environmentally sound management strategies for future disposal activities.

## PREFACE

This report presents the results of a 2-year investigation of the long-term impacts associated with the disposal of dredged material contaminated with polychlorinated biphenyls at an experimental open-water disposal site in Elliott Bay, Seattle, Washington. Appendices mentioned in this report contain raw data and are on file at the US Army Engineer Waterways Experiment Station, Environmental Laboratory. Work began in March 1979.

The investigation was performed as a component of the Dredging Operations Technical Support (DOTS) Program. The DOTS Program is funded by the Office, Chief of Engineers, through the Dredging Division of the Water Resources Support Center, Fort Belvoir, Va. Implementation of DOTS was assigned to the US Army Engineer Waterways Experiment Station (WES), Environmental Laboratory (EL), Vicksburg, Miss. Work at Elliott Bay was conducted under Contract No. DACW39-79-C-0038 between the URS Company, Seattle, Wash., and the WES. Authors of the report were Dr. Robert N. Dexter, Mr. Dale E. Anderson, and Ms. Elizabeth A. Quinlan.

This field study was conducted under the direction of WES principal investigator Dr. Henry E. Tatem, Environmental Research and Simulation Division (ERSD), and under the general supervision of Dr. Richard K. Peddicord, ERSD, and Mr. Donald L. Robey, Chief, ERSD. Contracting Officer's Representative was Dr. Robert M. Engler, ERSD.

The DOTS Program is conducted under the EL management unit, Environmental Effects of Dredging Programs (EEDP), Mr. Charles C. Calhoun, Jr., Manager. DOTS coordinator in EEDP is Mr. Thomas R. Patin. Dr. John Harrison is Chief, EL.

Commanders and Directors at WES during this work were COL Nelson P. Conover, CE, and COL Tilford C. Creel, CE. Technical Director was Mr. F. R. Brown.

This report should be cited as follows:

Dexter, R. N., Anderson, D. E., and Quinlan, E. A. 1984.  
"Long-Term Impacts Induced by Disposal of Contaminated  
River Sediments in Elliott Bay, Seattle, Washington,"  
Technical Report D-84-4, prepared by URS Company, Seattle,  
Wash., for the US Army Engineer Waterways Experiment  
Station, Vicksburg, Miss.

## ACKNOWLEDGEMENTS

We wish to gratefully acknowledge the participation in and contributions to this study by personnel of the Marine Technician Program at Shoreline Community College, Seattle, Washington. In particular, we wish to recognize the efforts of Professors John Serwold and Robert Harman, who were responsible for the taxonomic identifications and overall college management, and Kim Justus, field supervisor for the collection crews.

We also appreciate the efforts of James Eckman, Department of Oceanography, University of Washington, for his assistance and advice in the analysis of the biological data; of Dr. Robert Diaz, Virginia Institute of Marine Science, for quality control in enumeration and identification of the benthic organisms; and of Stag King, Department of Oceanography, University of Washington, for collecting and analyzing the interstitial water sulfide and nutrient samples.

We also acknowledge the contribution of Dr. Larry Larson, Department of Oceanography, University of Washington, in the deployment of the current meters and Sediment Dynamics Sphere tripod system.

Finally, we gratefully acknowledge efforts of Marc Patten, Wilson Hom, and Libby Goldstein while at URS in sample collection and PCB analyses; of Dr. Spyros Pavlou of JRB Associates, Inc., for helpful review and comment on this report; and of the URS production staff for their efforts in preparing this report. Graphics were prepared by Mike Bertman and word processing was performed by Kay Warczak.

## TABLE OF CONTENTS

	<u>Page No.</u>
EXECUTIVE SUMMARY	i
PREFACE	ii
ACKNOWLEDGEMENTS	iii
LIST OF TABLES	vi
LIST OF FIGURES	ix
CONVERSION FACTORS, U.S. CUSTOMARY TO METRIC (SI) UNITS OF MEASUREMENT	xvi
PART I: INTRODUCTION	1
Description of the Study Area	1
Description of the Disposal Monitoring Study	4
PART II: SAMPLE COLLECTION PROCEDURES	7
Station Locations	7
Sampling Scheme	12
Shipboard Procedures	28
Bathymetric Data Collection	33
Current Meter Deployment	34
PART III: LABORATORY PROCEDURES	36
Sediment Texture Analyses	36
Benthic Macrofauna Enumeration	38
PCB Analytical Procedures	41
Analytical Procedures for Sulfides, Nutrients, and Hydrographic Parameters	54
PART IV: DATA PROCESSING	56
Data Management	56
Data Analysis	57

## TABLE OF CONTENTS (CONT'D)

	<u>Page No.</u>
PART V: RESULTS OF THE GEOPHYSICAL STUDIES	67
Bathymetry	67
Sediment Texture	73
Current Measurements	86
Summary and Conclusions	91
PART VI: RESULTS OF THE BIOLOGICAL STUDIES	93
Biological Quality Assurance	93
Biological Characterization	96
PART VII: RESULTS OF THE CHEMICAL STUDIES	145
Bulk Sediment and Interstitial Water Chemistry	145
Water Column Studies	180
Summary of Abiotic Chemical Studies	190
Uptake of PCBs by Benthic Organisms	191
PART VIII: SUMMARY AND CONCLUSIONS	202
REFERENCES	204
APPENDIX A - STATION LOGS FOR ALL CRUISES*	
APPENDIX B - CORE DESCRIPTIONS FOR ALL CORES*	
APPENDIX C - MASTER LIST OF MACROFAUNA*	
APPENDIX D - REPORT: DYNAMICS OF ELLIOTT BAY*	
APPENDIX E - COMPUTER OUTPUT OF BIOLOGICAL ANALYSES*	

---

\* Appendices contain raw data. They are on file at the U. S. Army Engineer Waterways Experiment Station, Environmental Laboratory.



## LIST OF TABLES

<u>Table No.</u>	<u>Title</u>	<u>Page No.</u>
1	Criteria Used for the Definition of Sediment Types	77
2	Approximate Percentages of Sediment Types Comprising Visually Distinguishable Groups	78
3	Correlation Coefficients of Linear Regressions of Cruise Means Versus Time	79
4	Comparison of Variability within Cruises to Variability between Cruises	85
5	Summary of Mean Current Values	86
6	Sediment Transport Calculations	90
7	Ranking of Most Common Taxa from Cruises by Abundance	98
8	Ranking of Most Common Taxa from Cruises by Biomass	99
9	Ranking of Most Common Taxa from Cruises by Frequency of Occurrence	100
10	Possible Feeding Guild Characteristics of the Fifteen Most Abundant Polychaetes Found in Elliott Bay	101
11	Comparison of Select Taxa Mean Abundances, June 1976 to May 1980	103
12	Results of Mapping Analysis for Select Taxa from May 1979 Cruise	106
13	Results of Mapping Analysis for Select Taxa from October 1979 Cruise	107
14	Results of Mapping Analysis for Select Taxa from May 1980 Cruise	108

LIST OF TABLES (CONT'D)

<u>Table No.</u>	<u>Title</u>	<u>Page No.</u>
15	Summary of Cluster Analyses Performed on Biological Data	110
16	Results of Spatial Autocorrelation Analysis for Select Taxa Abundances of the May 1979 Cruise	132
17	Summary of Wilcoxon Two-Sample Tests Performed on the Biological Data	133
18	Results of Wilcoxon Two-Sample Tests for Select Taxa from Groups of Stations	134
19	Summary of Wilcoxon Two-Sample Test Results Showing Sensitivity of Cluster Analysis	136
20	Results of the Kendall's Correlation Analysis between Biological, Physical, and Chemical Mean Data - May 1979, October 1979 and May 1980 Cruises	138
21	Results of the Kendall's Correlation Analysis Between Biological, Physical, and Chemical Individual Sample Data -- October 1979 Cruise	142
22	Comparisons of Overall Mean Concentrations of t-CB, 3-CB, TOC, and O&G of Surface (0-6 cm) Dredged Material Sediments to the Corresponding Concentrations in the Surficial Non-Dredged Material Sediments	153
23	Comparisons Among Cruises of the Means and Standard Deviations of the t-CB Concentrations in the Dredged Material Sediments	157
24	Comparisons Among Cruises of the Mean Concentrations of t-CB in the Upper 10 cm of the Dredged Material Sediments	158

LIST OF TABLES (CONT'D)

<u>Table No.</u>	<u>Title</u>	<u>Page No.</u>
25	Comparisons Among Cruises of the Mean t-CB and 3-CB Concentrations and the Fraction of 3-CB to the Total PCB Concentration ( $F_3$ ) for the Upper Horizons of Dredged Material and Non-Dredged Material Sediments	159
26	Mean Concentrations of TOC per Horizon per Cruise for Dredged Material and Non-Dredged Material Sediments	163
27	Mean Concentrations of O&G per Horizon per Cruise for Dredged Material and Non-Dredged Material Sediments	165
28	Comparisons of the Mean Oil and Grease Concentrations in the Upper 10 cm of the Dredged Material Deposits Among Cruises	167
29	Mean Concentrations of $PO_4$ , $NH_4$ , and $SiO_4$ per Horizon per Cruise for the Interstitial Waters of the Dredged Material and Non-Dredged Material Sediments	179
30	Mean Concentrations per Cruise of Standard Hydrographic and Nutrient Parameters	181
31	Mean Concentrations of t-CB in the Water and Associated with the Suspended Particulate Matter	187
32	Benthic Macrofauna Samples Obtained from all Cruises	192
33	Comparisons of the Averaged t-CB and 3-CB Concentrations Observed in the Benthic Organisms and the Sediments for all Cruises	194
34	Linear Regression Equations Relating the t-CB Concentrations Observed in the Biota to the Mean Concentrations of the Corresponding Sediments at each Station	199

## LIST OF FIGURES

<u>Figure No.</u>	<u>Title</u>	<u>Page No.</u>
1	Elliott Bay Location Map	2
2	Original Station Grid	5
3	Comparison of the Location of the 16 Stations of the (A) Original Sampling Grid, (B) to the Locations of the Stations for the Present Study	8
4	Station Location Randomization Procedure	10
5	Station Locations - Reconnaissance Cruise, February 1979	11
6	Station Locations (May 1979 Cruise), Grab Samples for Benthic Fauna Characterization	13
7	Station Locations (May 1979 Cruise), Gravity Cores for Grain Size and Interstitial Water Analysis	14
8	Station Locations (May 1979 Cruise), Samples for PCB Content of Sediments and Interstitial Water	15
9	Station Locations (May 1979 Cruise), Grab Samples for PCB Content of Biota	16
10	Station Locations (May 1979 Cruise), Water Samples for PCB Content of Water and SPM and Hydrocasts	17
11	Station Locations (October 1979 Cruise), Grab Samples for Benthic Fauna Characterization	18
12	Station Locations (October 1979 Cruise), Gravity Cores for Grain Size and Interstitial Water Analysis	19
13	Station Locations (October 1979 Cruise), Samples for PCB Content of Sediments and Interstitial Water	20
14	Station Locations (October 1979 Cruise), Grab Samples for PCB Content of Biota	21

LIST OF FIGURES (CONT'D)

<u>Figure No.</u>	<u>Title</u>	<u>Page No.</u>
15	Station Locations (October 1979 Cruise), Water Samples for PCB Content of Water and SPM and Hydrocasts	22
16	Station Locations (May 1980 Cruise), Grab Samples for Benthic Fauna Characterization	23
17	Station Locations (May 1980 Cruise), Gravity Cores for Grain Size and Interstitial Water Analysis	24
18	Station Locations (May 1980 Cruise), Samples for PCB Content of Sediments and Interstitial Water	25
19	Station Locations (May 1980 Cruise), Grab Samples for PCB Content of Biota	26
20	Station Locations (May 1980 Cruise), Water Samples for PCB Content of Water and SPM and Hydrocasts	27
21	Flow Diagram for Sediment Texture Analysis	37
22	Flow Diagram for Macrofauna Enumeration Procedure	39
23	Flow Scheme of the Extraction Procedure for Water Samples	43
24	Projection and Perspective Drawings of the Teflon-Stopper Solvent Extractor Apparatus	44
25	Flow Scheme of the Extraction Procedure for Interstitial Water Samples	46
26	Flow Scheme of the Extraction Procedure for Filtered Suspended Sediments	47
27	Flow Scheme of the Extraction Procedure for Sediment Samples	49
28	Flow Scheme of the Extraction Procedure for Invertebrate Samples	51
29	Typical Dendrogram Resulting from Cluster Analysis	61
30	Bathymetric Map of the General Disposal Area	68

LIST OF FIGURES (CONT'D)

<u>Figure No.</u>	<u>Title</u>	<u>Page No.</u>
31	Detailed Bathymetric Map of the Disposal Site, December 1978 Survey	69
32	Three-Dimensional Representation of the Bottom Topography of the Study Area	70
33	The Difference in Depth (in feet) Between the August 1979 and December 1978 Surveys	71
34	East-West Transects Through the Disposal Site	72
35	Distribution of Mean Phi for Stations Outside the Grid Area	74
36	Distribution of Percent Sand for Stations Outside the Grid Area	75
37	Contour Plot of the Depth of the MS Subsurface Horizon	80
38	Distribution of the Mean Phi of the Predisposal Surface Layer	81
39	Groupings Used for Temporal Trend Analysis	82
40a	Linear Regression of Cruise Means of Percent Sand versus Time	83
40b	Linear Regression of Cruise Means of Mean Phi versus Time	84
41	Mean Current Vectors and Bathymetry (ft) at Mooring Site During August - September 1980	87
42	Daily Maximum Current Speed versus Probability	89
43	Spatial Distribution of Polychaete Family Capitellidae	105
44a	Cluster Analysis Dendrogram for Samples (station replicates) of May 1979 Macrofauna Abundances, Code C2C1	111

LIST OF FIGURES (CONT'D)

<u>Figure No.</u>	<u>Title</u>	<u>Page No.</u>
44b	Cluster Analysis Dendrogram for Station Means of May 1979 Macrofauna Abundances, Code C2MC	112
44c	Cluster Analysis Dendrogram for Station Medians of May 1979 Macrofauna Abundance, Code C2MC	113
45a	Cluster Analysis Groupings for Samples (Station Replicates) of May 1979 Macrofauna Abundances, Code C2C1	115
45b	Cluster Analysis Groupings for Station Means and Medians of May 1979 Macrofauna Abundances, Codes C2MC	116
46a	Cluster Analysis Groupings for Samples (Station Replicates) of May 1979 Macrofauna Biomasses, Code C2W1	117
46b	Cluster Analysis Groupings for Station Means and Medians of May 1979 Macrofauna Biomasses, Codes C2MW and C2MDW	118
47a	Cluster Analysis Groupings for Samples (Station Replicates) of October 1979 Macrofauna Abundances, Code C3C1	119
47b	Cluster Analysis Groupings for Station Means of October 1979 Macrofauna Abundances, Code C3MC	120
47c	Cluster Analysis Groupings for Station Medians of October 1979 Macrofauna Abundances, Code C3MDC	121
48a	Cluster Analysis Groupings for Samples (Station Replicates) of October 1979 Macrofauna Biomasses, Code C3W1	122
48b	Cluster Analysis Groupings for Station Means of October 1979 Macrofauna Biomasses, Code C3MW	123
48c	Cluster Analysis Groupings for Station Medians of October 1979 Macrofauna Biomasses, Code C3MDW	124

LIST OF FIGURES (CONT'D)

<u>Figure No.</u>	<u>Title</u>	<u>Page No.</u>
49a	Cluster Analysis Groupings for Sample (Station Replicates) of May 1980 Macrofauna Abundances, Code C4C1	126
49b	Cluster Analysis Groupings for Station Medians of May 1980 Macrofauna Abundances, Code C4MDC	127
50a	Cluster Analysis Groupings for Sample (Station Replicates) of May 1980 Macrofauna Biomasses, Code C4W1	128
50b	Cluster Analysis Groupings for Station Medians of May 1980 Macrofauna Biomasses, Code C4MDW	129
50c	Cluster Analysis Groupings for Station Means of May 1980 Macrofauna Biomasses, Code C4MW	130
51	Scatter Plot of <u>Praxilella gracilis</u> versus Percent Sand, May 1979	139
52	Scatter Plot of <u>Paraonella spinifera</u> versus Percent TOC, May 1979	140
53	Contour Plot of the Concentration of Total-CB Observed in the Surface Sediment Horizon	146
54	Concentration Contours of the Approximate Distribution of t-CB in the Surface Sediments	148
55	Concentration Contours of the Approximate Distribution of 3-CB in the Surface Sediments, Cruises 1, 2, 3, and 4	149
56	Dendrogram of Sediment Clustering of February 1979, PCB Data	151
57	Histogram Showing Relationship of 3-CB Concentration to Sediment Type	152
58	Contours of the Approximate Concentrations of t-CB in Background Sediments at the Disposal Site together with Surface Sediments at Non-Dredged Material Sites, Cruises 1, 2, 3, and 4	155



LIST OF FIGURES (CONT'D)

<u>Figure No.</u>	<u>Title</u>	<u>Page No.</u>
59	Depth Profiles of the t-CB Concentrations in the Dredged Material Cores	156
60	Depth Profiles of the t-CB Concentrations in the Non-Dredged Material Cores	162
61	Contours of the Approximate Percent TOC of the Surface Sediments, Cruises 2, 3, and 4	164
62	Spatial Distribution of O&G in the Surface Sediments	166
63	Plot of the Percent of TOC Versus the Grain Size of the Sediments for a) Dredged Material Samples and b) Non-Dredged Material Samples	168
64	Plots of the t-CB Concentrations Versus the Grain Size of the Sediments for a) Dredged Material Samples and b) Non-Dredged Material Samples	169
65	Plots of the Concentrations of O&G Versus the Grain Size of the Sediments	170
66	Plots of the Concentrations of t-CB and O&G Versus the Percent TOC of the Sediments	171
67	Plot of the Concentrations of t-CB Versus the Concentrations of O&G in the Sediments	172
68	Summary of Correlations Between Physical and Chemical Parameters	174
69	Concentrations of t-CB, ng/l in Interstitial Water	176
70	Concentrations of $\text{NH}_4$ in the Water Column as a Function of Salinity, Cruises 2, 3, and 4	185
71	Plots of the Mean Concentrations of t-CB Observed in the (a) Suspended Particulate Matter and (b) Water Versus Salinity	189

LIST OF FIGURES (CONT'D)

<u>Figure No.</u>	<u>Title</u>	<u>Page No.</u>
72	Mean Concentration in the Benthic Macrofauna versus the Mean Concentration in the Surface Sediments from each Sampling Station for a) t-CB and b) 3-CB	195
73	Plots of the Concentrations of t-CB Observed in the Individual Benthic Macrofauna Taxa Versus the Average t-CB Concentration in the Sediments from the Same Sampling Site	197

CONVERSION FACTORS, U.S. CUSTOMARY TO  
METRIC (SI) UNITS OF MEASUREMENT

U.S. customary units of measurement used in this report can be converted to metric (SI) units as follows:

<u>Multiply</u>	<u>By</u>	<u>To Obtain</u>
cubic feet per second	0.02831685	cubic meters per second
cubic yards	0.7645549	cubic meters
feet	0.3048	meters
gallons (U.S. liquid)	3.785412	cubic decimeters
inches	25.4	millimeters
pounds (force) per square inch	6894.757	pascals
yards	0.9144	meters

LONG-TERM IMPACTS INDUCED BY DISPOSAL  
OF CONTAMINATED RIVER SEDIMENTS IN ELLIOTT BAY  
SEATTLE, WASHINGTON

PART I: INTRODUCTION

The Aquatic Disposal Field Investigation (ADFI) in Elliott Bay, Seattle, Washington, was initiated in February 1976 as part of the Environmental Impacts and Criteria Development Project of the U.S. Army Corps of Engineers, Waterways Experiment Station, Vicksburg, Mississippi. The ADFI study was a major research project within the Dredged Material Research Program (DMRP) designed to evaluate the ecological effects of open-water disposal of dredged material. Among four coastal ADFI sites, Elliott Bay was the only deepwater estuarine location where dredged material disposal by barges was investigated and where the disposal involved the discharge of sediments contaminated with polychlorinated biphenyls (PCBs). Therefore, the potential adverse biological consequences that could result from the release of PCBs induced by these activities made this site particularly appropriate for study. Under the DMRP, the disposal operation and post-disposal impacts were monitored for nine months after the disposal event. The study presented herein, conducted under the Dredging Operations Technical Support Program, was designed to provide additional, long-term evaluation of the Elliott Bay site.

Description of the Study Area

Elliott Bay is situated midway on the eastern shore of the Main Basin of Puget Sound (Figure 1). The surface area of the bay is approximately 14.4 km<sup>2</sup> and is defined by Magnolia Bluff on the northwest and on the southwest by Duwamish Head. Volume of the bay comprises approximately 0.5 percent of the total Puget Sound volume. Bottom topography is characterized by steep marginal shore slopes around a 130-m-deep internal basin. This basin slopes gently to the northwest until it merges with the Main Basin of Puget Sound.

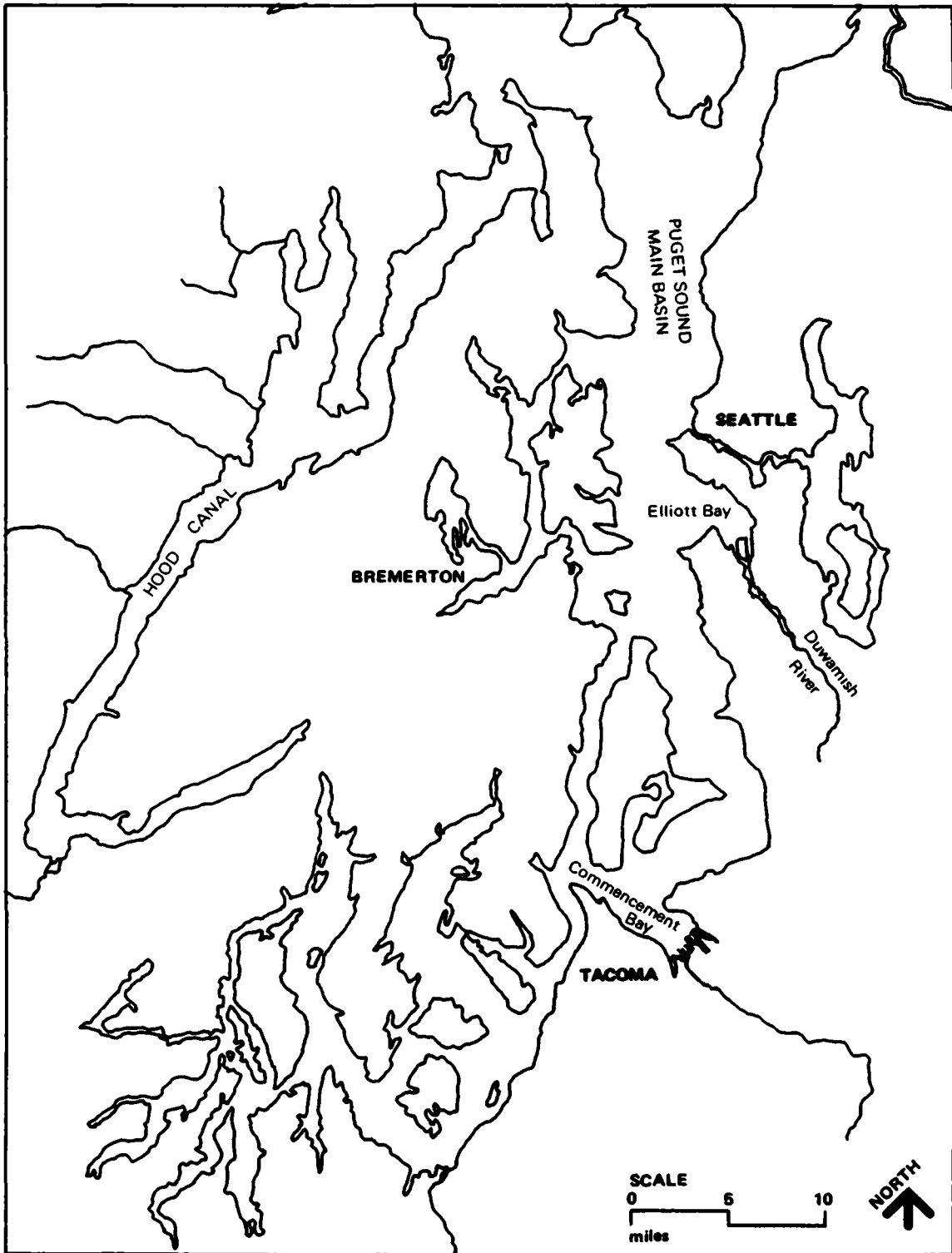

Figure 1. Elliott Bay Location Map

The southern portion of the bay is divided into two smaller basins by a bottom ridge which slopes northwesterly from the northern end of Harbor Island and extends to the center of the bay. This ridge may represent a delta built by the Duwamish River, which discharges into the southern portion of the bay.

Currents in Elliott Bay are tidally dominated. Net circulation in the surface layer (<35 m) is generally counterclockwise. Net deep-water circulation in the vicinity of the disposal site is to the south or southeast. Residence time of water in the bay has been estimated to range from three to ten days.

The Duwamish River provides freshwater input to Elliott Bay at an average annual rate of about 1,300 cfs\* (U.S. Environmental Protection Agency, 1974). Flow is highly seasonal, reflecting the variations in precipitation and snowmelt. River discharge normally increases in late fall and again in late spring. The lower Duwamish forms a vertically stratified salt-wedge estuary with net outflow of fresh to brackish water at the surface and net inflow (upriver) of saline Elliott Bay water at depth. The highly variable flow of fresh water is usually seaward. However, instantaneous movement in both layers may be either upstream or downstream. At its mouth, the river is split and discharges into Elliott Bay around Harbor Island. Dredging of the western channel and a shallow sill at the south end of the eastern channel result in the majority of the water exchange taking place via the West Waterway. The freshwater discharge forms a low salinity surface plume (1-15 m) in the southern portion of the bay. The behavior of this plume reflects a response to both tidal currents and wind stress. In the absence of strong southerly winds, the plume is "compressed" into the southern bay around the river mouth by flood tides. During ebb tides, the plume normally drifts northward, spreading along the northeastern waterfront and following the shoreline until its identity is lost by mixing with Puget Sound surface water. As a result, the primary influence of the river discharge is felt in the southern and southeastern portions of Elliott Bay and along the Seattle waterfront.

---

\* A table of factors for converting U.S. customary units of measure to metric (SI) units is presented on Page xvi.

The presence of PCBs in Puget Sound has been known since 1972. In general, PCB concentrations were found to correlate with sites of increased industrial and municipal activity with no apparent temporal trends. The highly industrialized Duwamish Estuary contained the highest PCB concentrations observed in the Sound. Elliott Bay, which receives the Duwamish River discharge, also was found to contain elevated PCB levels showing a spatial distribution in surface sediments that decreased with distance from the mouth of the river. A recent examination of the PCB levels in the sediments of Elliott Bay and the Duwamish River suggests that the history of PCB input into this area has been sporadic over a long period of time. Sediment cores often show marked differences in both the PCB types and their total concentrations as a function of the core depth. A detailed discussion on these aspects is presented in Pavlou and Dexter (1979) and Hom (1979).

#### Description of the Disposal Monitoring Study

The dredging and disposal operations were initiated in February 1976 and completed in March 1976. A clamshell bucket dredge and two split-hull barges of approximately 1100 m<sup>3</sup> combined capacity were used in the operation. The total volume of material disposed in Elliott Bay was approximately 114,000 m<sup>3</sup>. The source of these sediments was a 1.88-km stretch of the upper Duwamish Estuary between river kilometers 6.28 and 8.16. The disposal site is located over the 60-m depth isoline due north of the mouth of the West Waterway (47°37'41" N; 122°21'42" W) within the sixteen station sampling grid of 0.13 km<sup>2</sup> shown in Figure 2. Two reference areas were also located in 60 m of water and positioned east and west of the disposal site (Figure 2). The west reference site historically has received the least impact from the municipal, commercial, and industrial activities of the Seattle area. Water flow over this location originates primarily from the Main Basin of Puget Sound rather than from the interior of Elliott Bay. The east reference site has received effluents from the Duwamish River and from sewage overflow discharges along the Seattle waterfront.

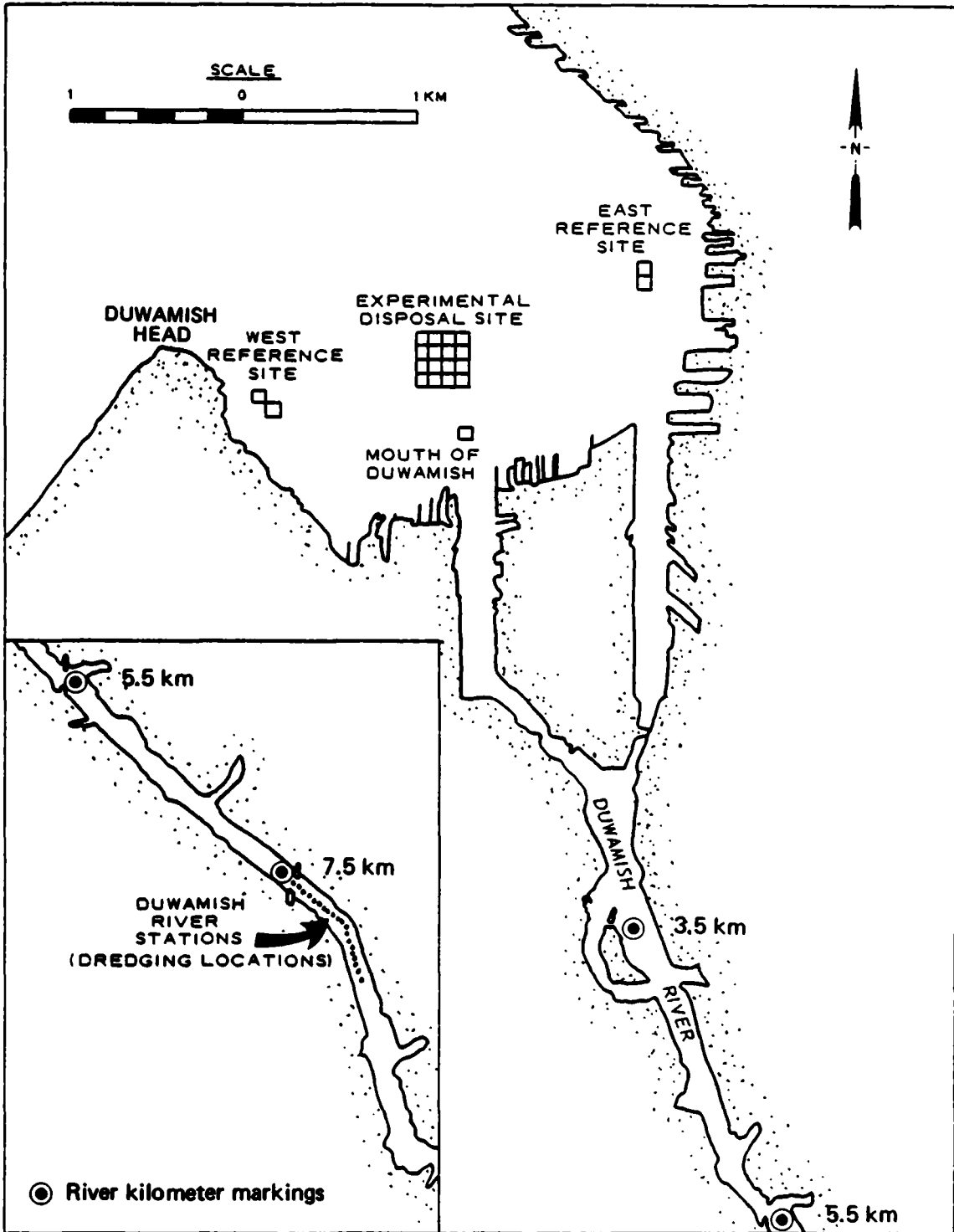

Figure 2. Original Station Grid



In the original short-term study (Tatem and Johnson, 1978), impacts to the biota, sediments, and water column were examined at disposal and reference sites before, during, and for nine months after disposal. Results of these investigations have been presented in Tatem and Johnson (1978), and are discussed where appropriate in the Results and Discussion section of this report.

The present study, initiated in February 1979, was designed to consider four areas which could not be adequately addressed during the original study:

- A. Physical stability of the dredged material deposit at the low-energy, deepwater Elliott Bay site.
- B. Long-term effects of the dredged material on the benthic macrofauna, one group of organisms which did not fully recover in the first nine months after disposal.
- C. Chemical and diffusional stability of the PCBs associated with the dredged material.
- D. Whether significant uptake of PCBs by the resident macrofauna was occurring.

The sampling design, analytical procedures, and final results of the continuation study are presented in this report. Included are results of an initial reconnaissance cruise conducted in February 1979 and three detailed study cruises conducted in May 1979, October 1979, and May 1980.

The presentation follows a standard scientific report format with sections devoted to the methods of sample collection, analyses, and data processing; results and discussion that summarize major findings; and appendices that present more detailed information.

## PART II: SAMPLE COLLECTION PROCEDURES

Detailed station logs including station number, location, type of sample, sampling time and depth, and other data are presented for all cruises in Appendix A. A summary of the sampling procedures is presented below.

### Station Locations

Thirty stations were sampled during the reconnaissance cruise. Twelve were located within the original grid established during the short-term study in 1976. The other 18 stations, located at random angles, were increasing distances away from the grid, as described below.

The original grid was comprised of 16 stations in a 4 x 4 square pattern (Figure 3a). Of these, the four center stations and four corner stations were retained. The other 4 stations were chosen at intermediate locations determined in the following manner:

- A. Circles having radii of 64.7 and 194 m, both centered on the grid center, were drawn through the four central and four corner stations.
- b. Another circle having a radius of 129.3 m was drawn between these two circles.
- c. Four equally spaced stations were plotted on the middle circle such that they were each offset 45° from the other stations. Stations were numbered as shown in Figure 3b.

The other 18 stations were chosen in the area immediately outside the original grid. Eighteen random numbers were selected from a random numbers table. These numbers were set equal to compass angles to establish geographic directions. For example, 0 or 360 represented north, 90 or 450 represented east. The first station plotted outside the grid, station 113, was located 35 m away from the outermost grid circle (229 m from the center of the grid) and at a compass siting of

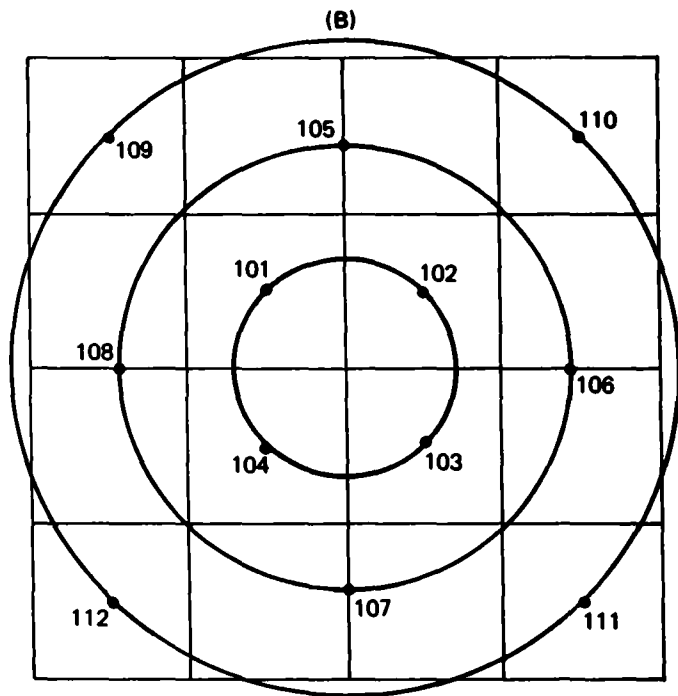
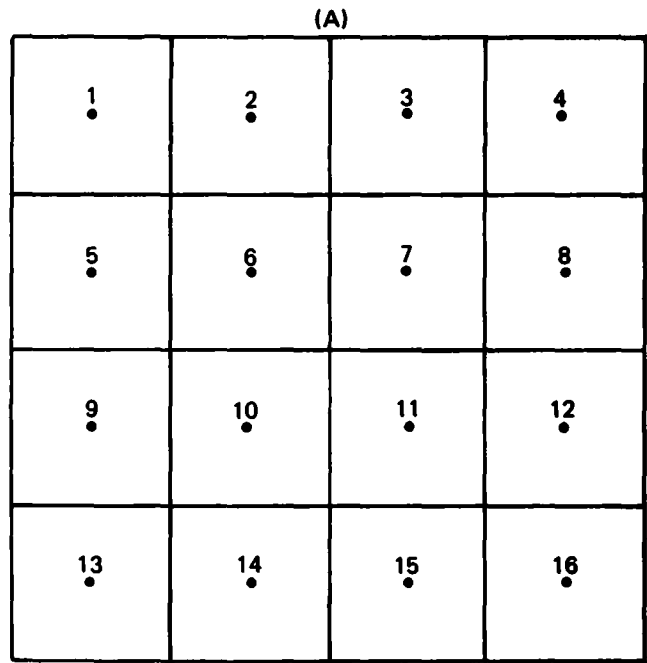

Figure 3. Comparison of the Location of the 16 Stations of the (A) Original Sampling Grid, (B) to the Locations of the Stations for the Present Study

348°, obtained from the random numbers table. Each successive station was located 35 m farther away from the center of the grid and at randomly selected angles. This randomization procedure is illustrated in Figure 4.

For the other three cruises, 20 stations were sampled. During each cruise, 9 or 10 of the 12 stations within the original grid were reoccupied. A new station located at the center of the original grid was occupied on the last two cruises. Outside the original grid, new stations were chosen at random angles and at an increased distance (60 m) away from the grid. Re-randomizing stations eliminated bias and provided a greater spatial distribution of samples.

For each cruise, the stations were plotted on standard nautical charts of Elliott Bay. Two points were chosen as mini-ranger transponder locations: the creosote dock at 47° 35' 7.4" N, 122° 22' 2" W, and the Port of Seattle dock at 47° 35' 24.8" N, 122° 20' 45.4" W. The distances between all stations and these two points were measured from the chart and converted to meters from the chart scale to give the mini-ranger coordinates for the stations.

During the reconnaissance cruise (February 1979), the mini-ranger failed to function and stations were located using the ship's radar. [This system is accurate to 0.01 nautical miles (19 m)]. Fortunately, winds and tides were low in February and little movement of the boat occurred while on station. As a result, the precision of repeated sampling from the same location was good, but the precision of the station fix was less than that obtainable with the mini-ranger. After the cruise, the radar ranges were converted to mini-ranger coordinates and the actual station locations were replotted (Figure 5).

During the remaining cruises, the mini-ranger functioned properly and was used to obtain all station locations. During these cruises, fairly high winds were sometimes encountered that resulted in significant movement of the boat while the samples were being collected, even though the ship was anchored for most samples. To account for the shifting, mini-ranger coordinates were obtained for the individual samples at the moment when the sampling equipment collected the sample, e.g., when the van Veen grab reached bottom. These individual sample

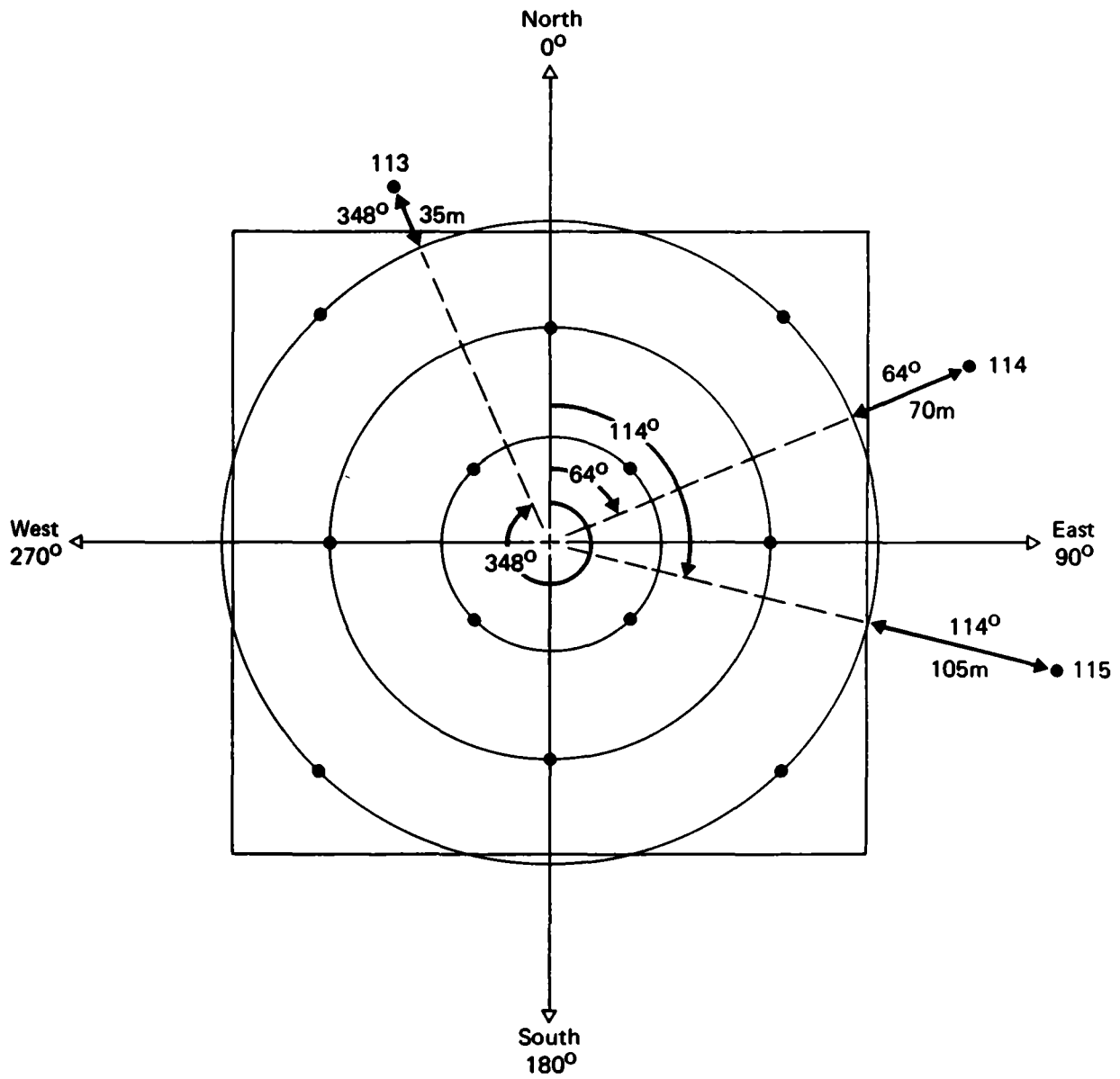

Figure 4. Station Location Randomization Procedure

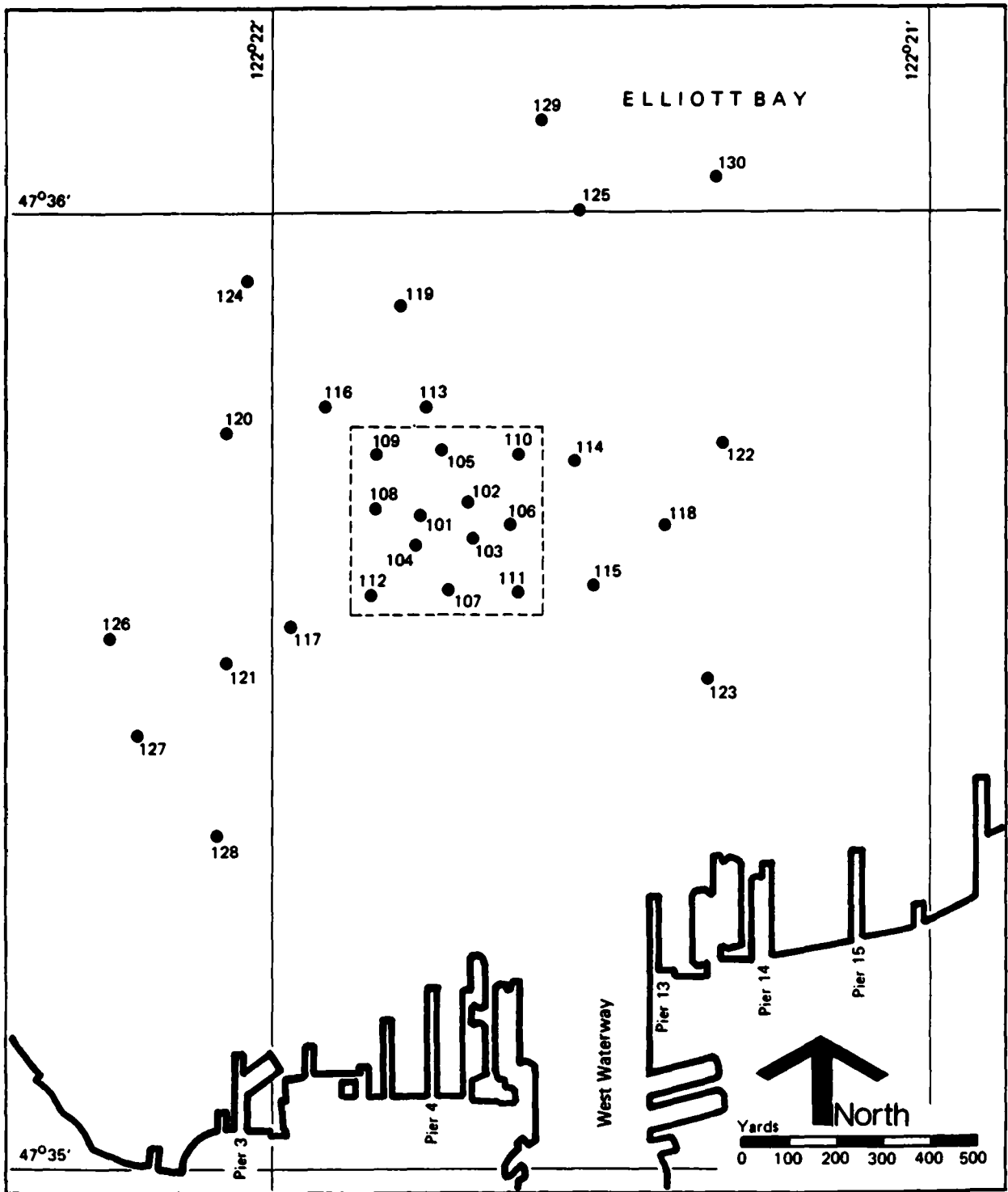

Figure 5. Station Locations - Reconnaissance Cruise, February 1979

locations were also replotted after the cruise. Sample locations for the different types of data for the May 1979, October 1979, and May 1980 cruises are presented in Figures 6 through 20.

### Sampling Scheme

Detailed records of the samples collected at each station are presented in Appendix A. The following general scheme was used. During the reconnaissance cruise samples for benthic fauna characterization were collected by van Veen grab at each station. At five stations (104, 106, 110, 117, and 132), triplicate gravity cores were collected and split for PCB and sediment texture analyses. Triplicate cores were taken to determine the amount of variability that existed in a small area. At each of the remaining 25 stations one gravity core was collected.

The sampling scheme for the three other cruises was quite different from that used for the reconnaissance cruise. Five stations were selected for intensive sampling during each cruise. At each of these five stations, the following sediment samples were collected:

- A. Three van Veen grabs for benthic fauna characterization.
- B. Two gravity cores for PCB and sediment texture analysis and one additional core for sediment analysis only.
- C. Two van Veen grabs for determination of the PCB content of the interstitial water (May 1979 cruise only).
- D. Two gravity cores for measurement of nutrients and sulfide in the interstitial water.
- E. Eight to 14 van Veen grabs for determination of the PCB content of the biota. (During the October 1979 and May 1980 cruises, subsamples from each of the first eight grabs were collected for the determination of the PCB content of interstitial water.)

Water samples were also collected at these five stations as well as at two additional stations where only water was collected. The following water samples were obtained:

- A. Four large-volume water samples for determination of the PCB content of the water and suspended particulate matter (SPM), two each at 1 and 10 m above the bottom.

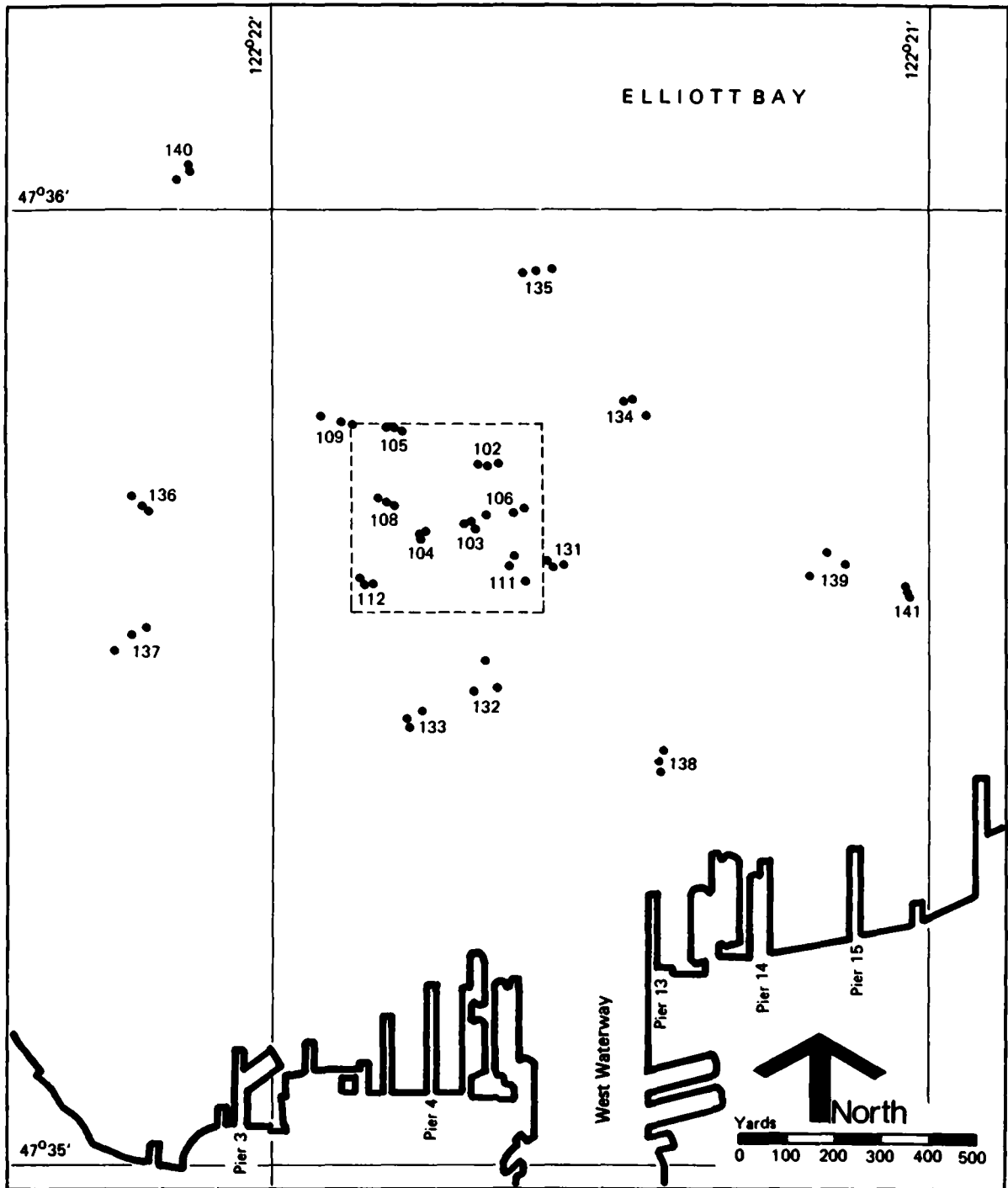

Figure 6. Station Locations (May 1979 Cruise), Grab Samples for Benthic Fauna Characterization



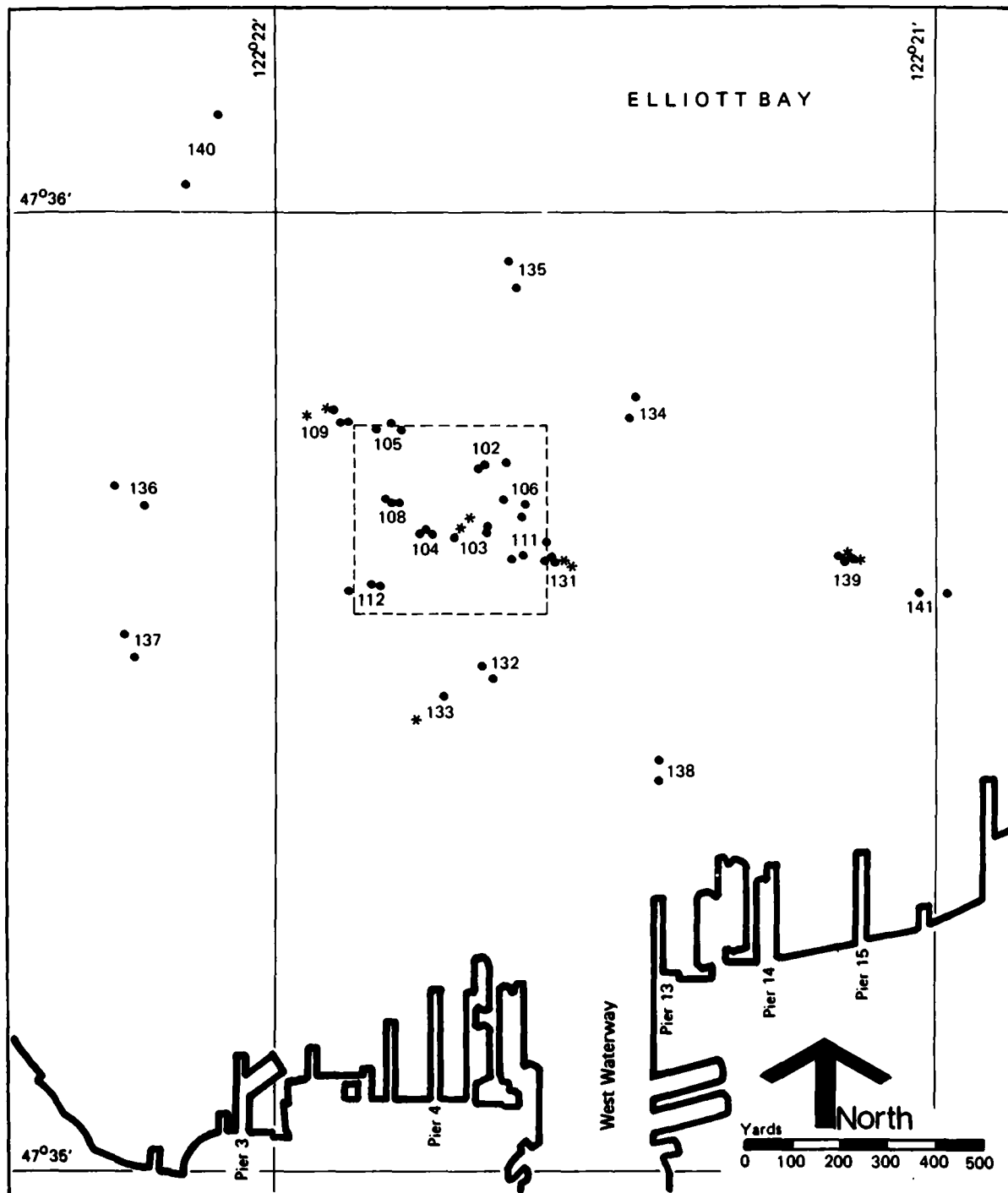

Figure 7. Station Locations (May 1979 Cruise), Gravity Cores for Grain Size • and Interstitial Water Analysis \*

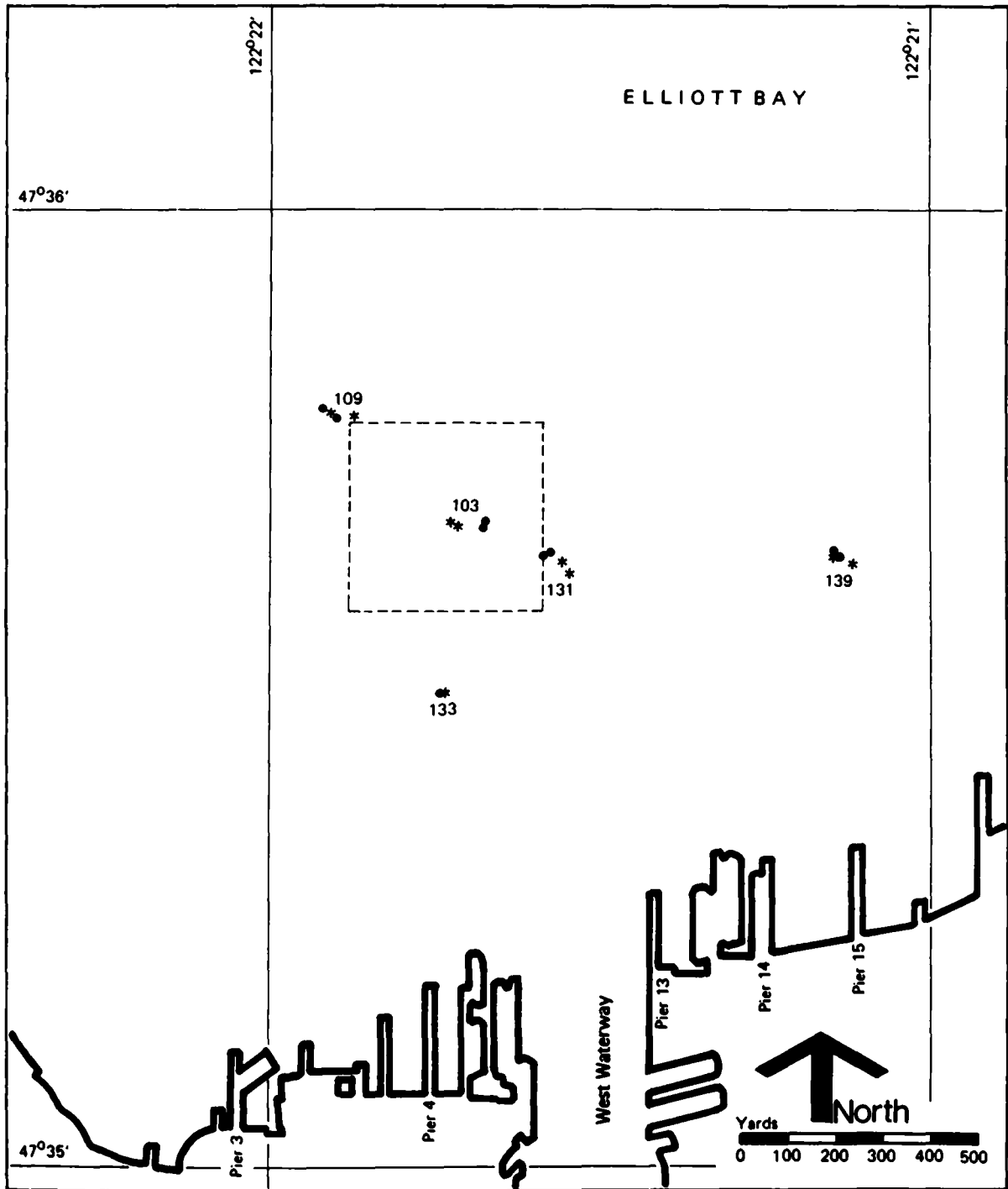

Figure 8. Station Locations (May 1979 Cruise), Samples for PCB Content of Sediments • and Interstitial Water \*

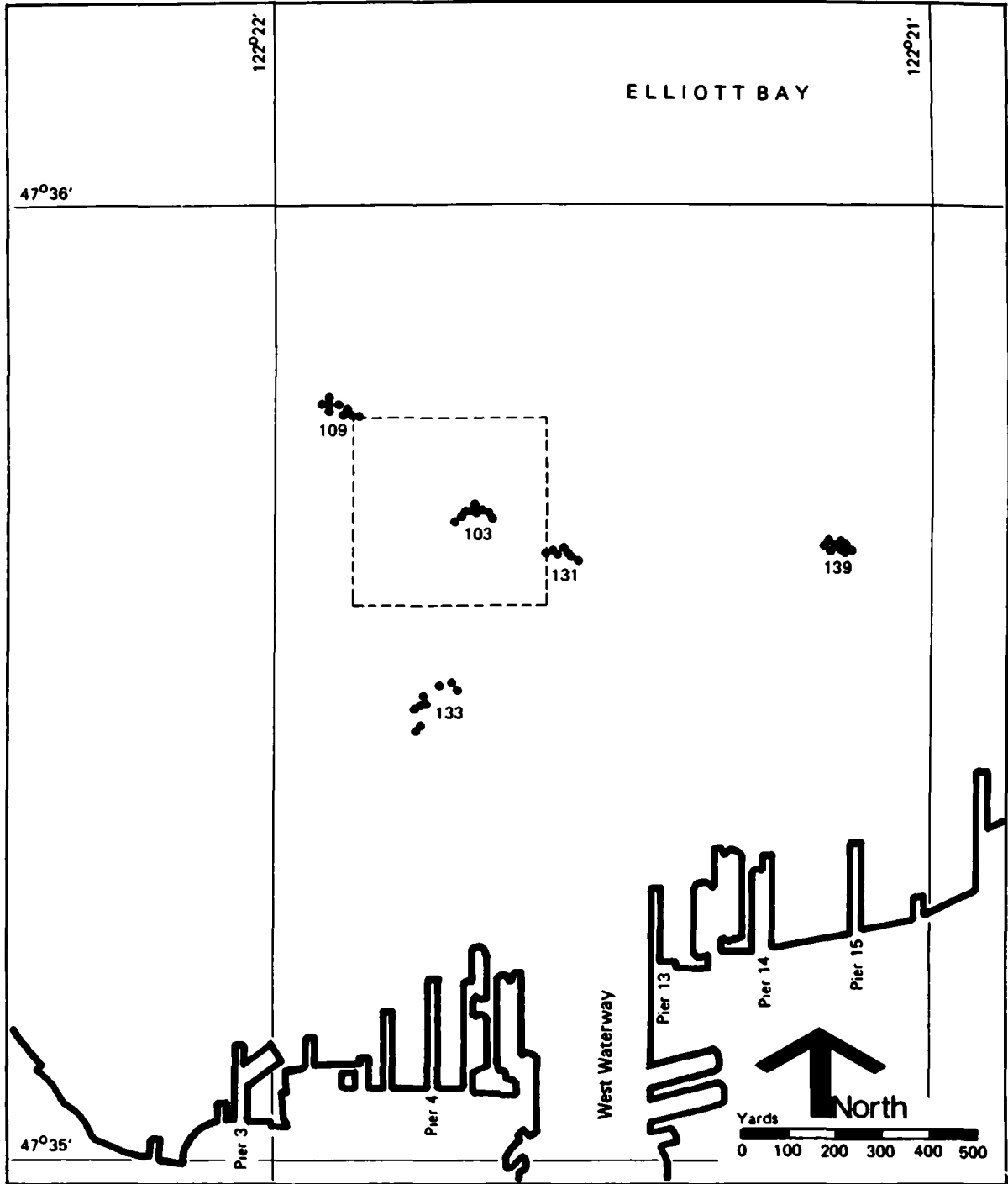

Figure 9. Station Locations (May 1979 Cruise), Grab Samples for PCB Content of Biota

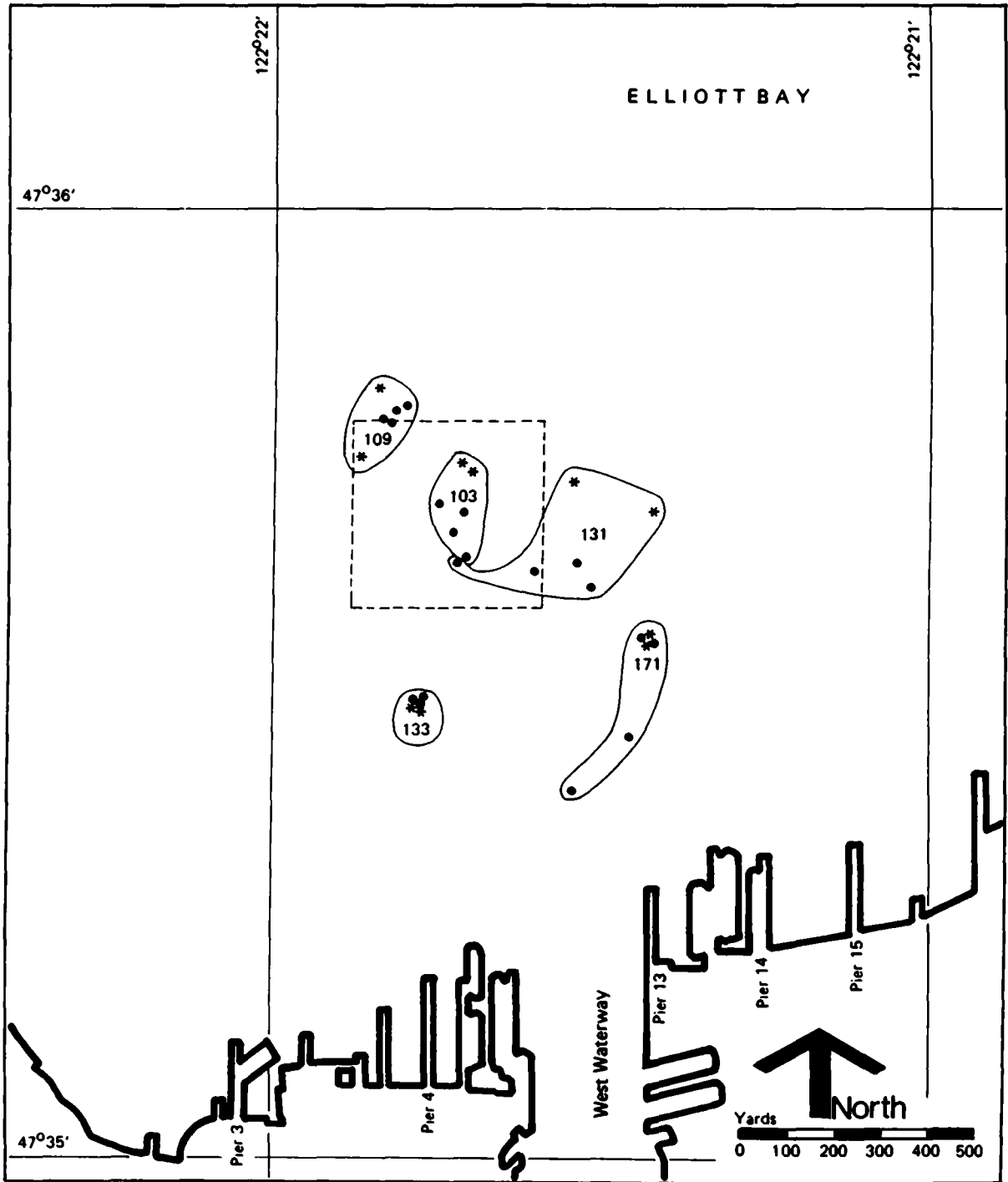

Figure 10. Station Locations (May 1979 Cruise), Water Samples for PCB Content of Water • and Suspended Particulate Matter and Hydrocasts\*

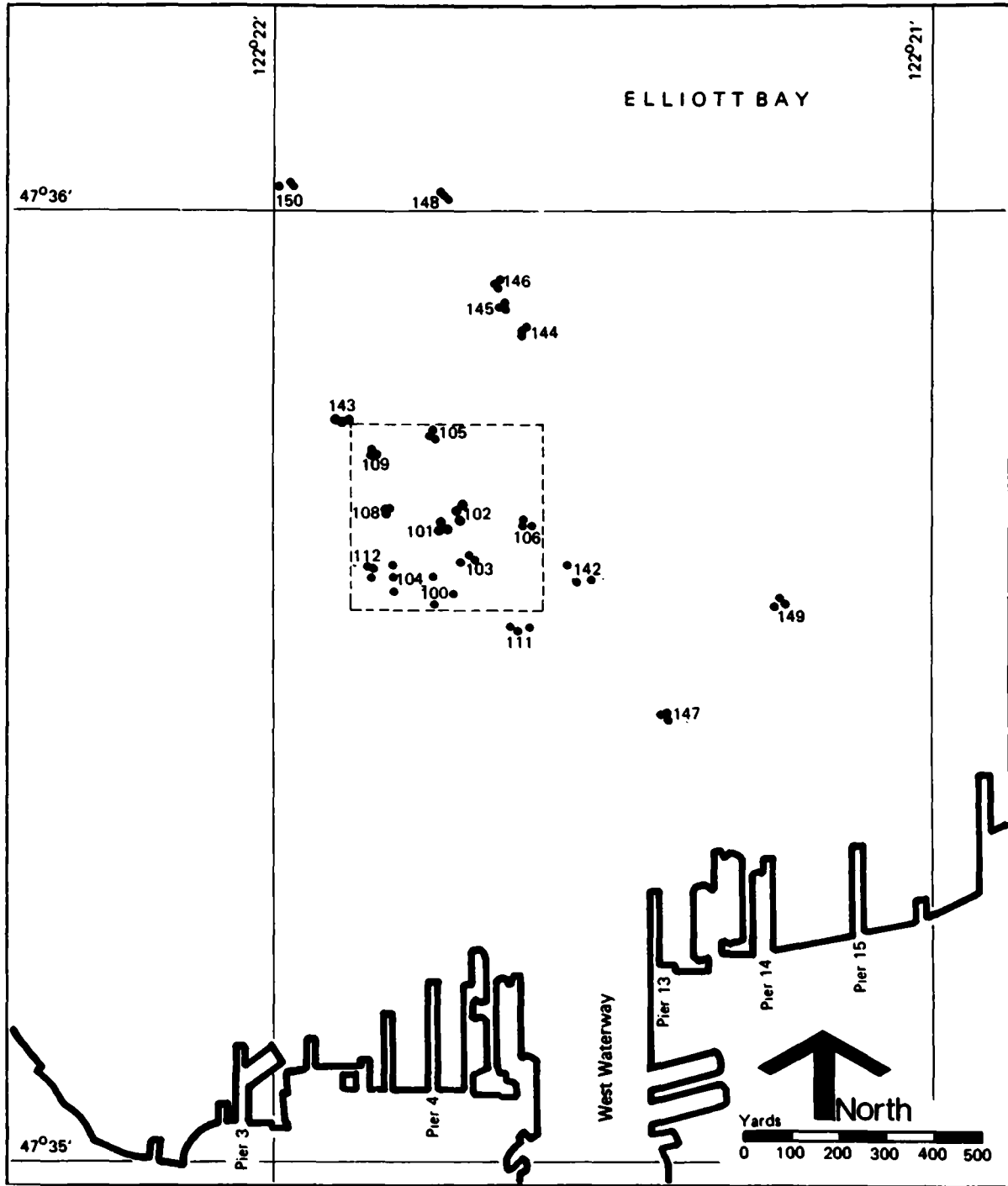

Figure 11. Station Locations (October 1979 Cruise), Grab Samples for Benthic Fauna Characterization

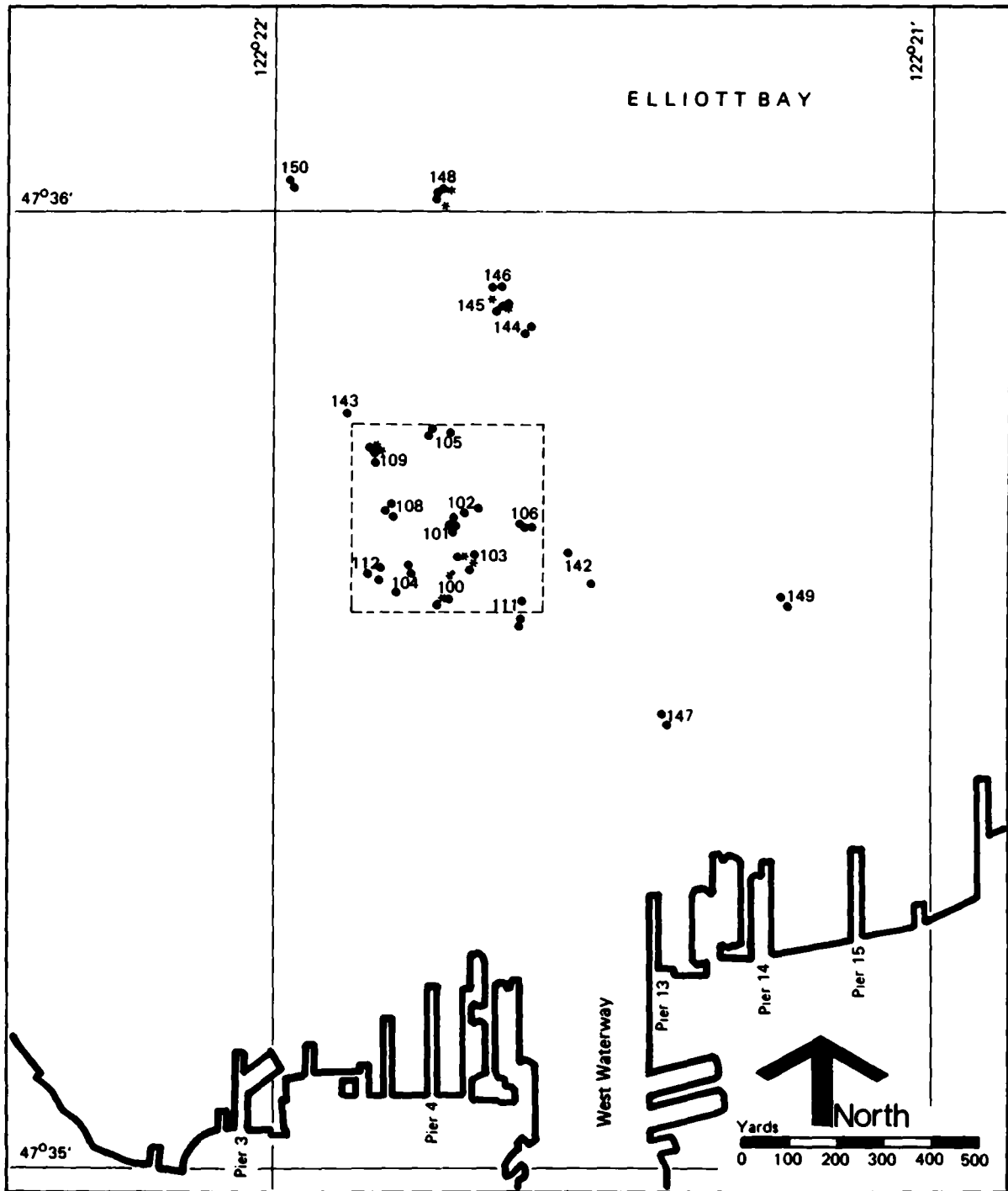

Figure 12. Station Locations (October 1979 Cruise), Gravity Cores for Grain Size \* and Interstitial Water Analysis •

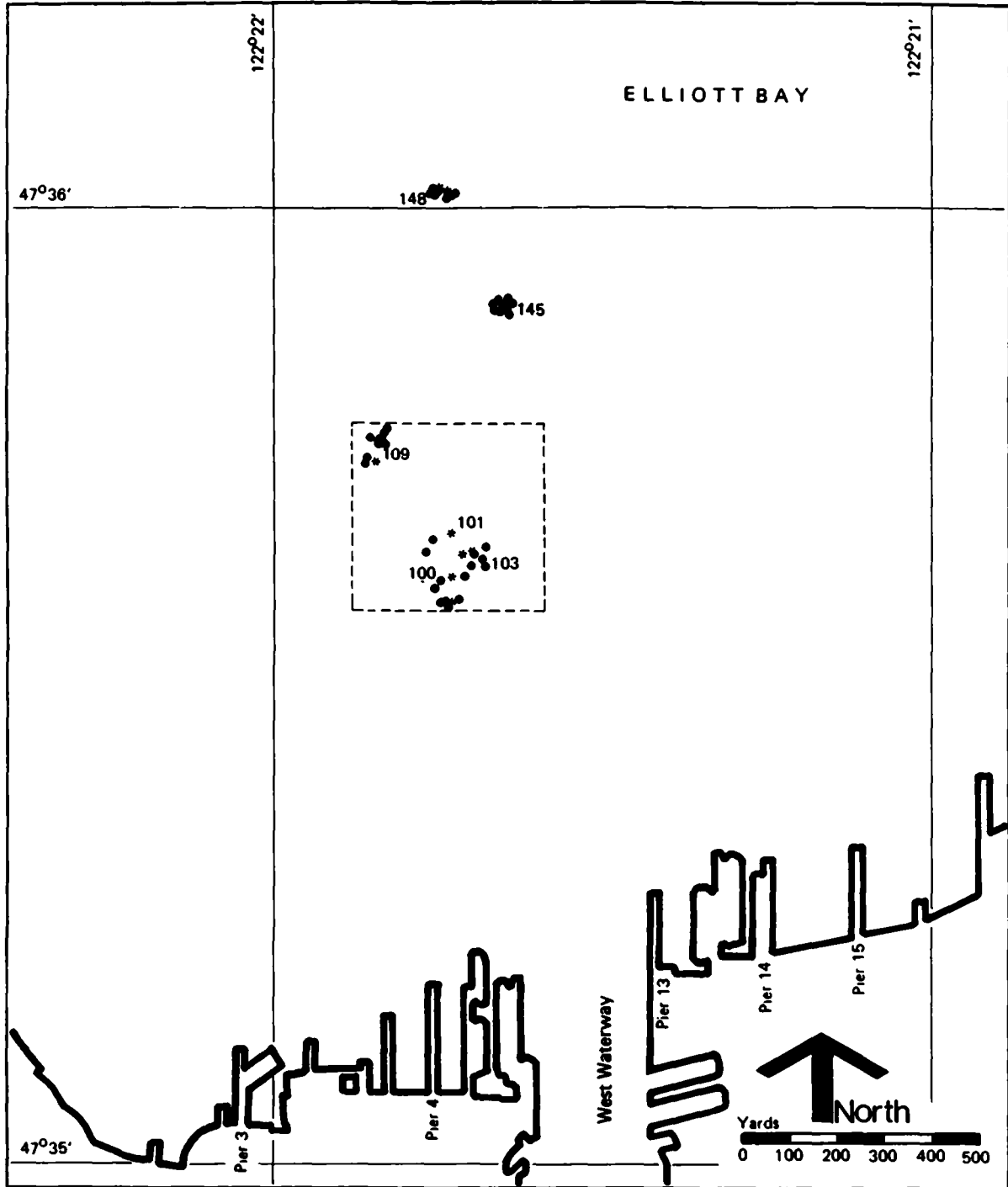

Figure 13. Station Locations (October 1979 Cruise), Samples for PCB Content of Sediments\* and Interstitial Water•

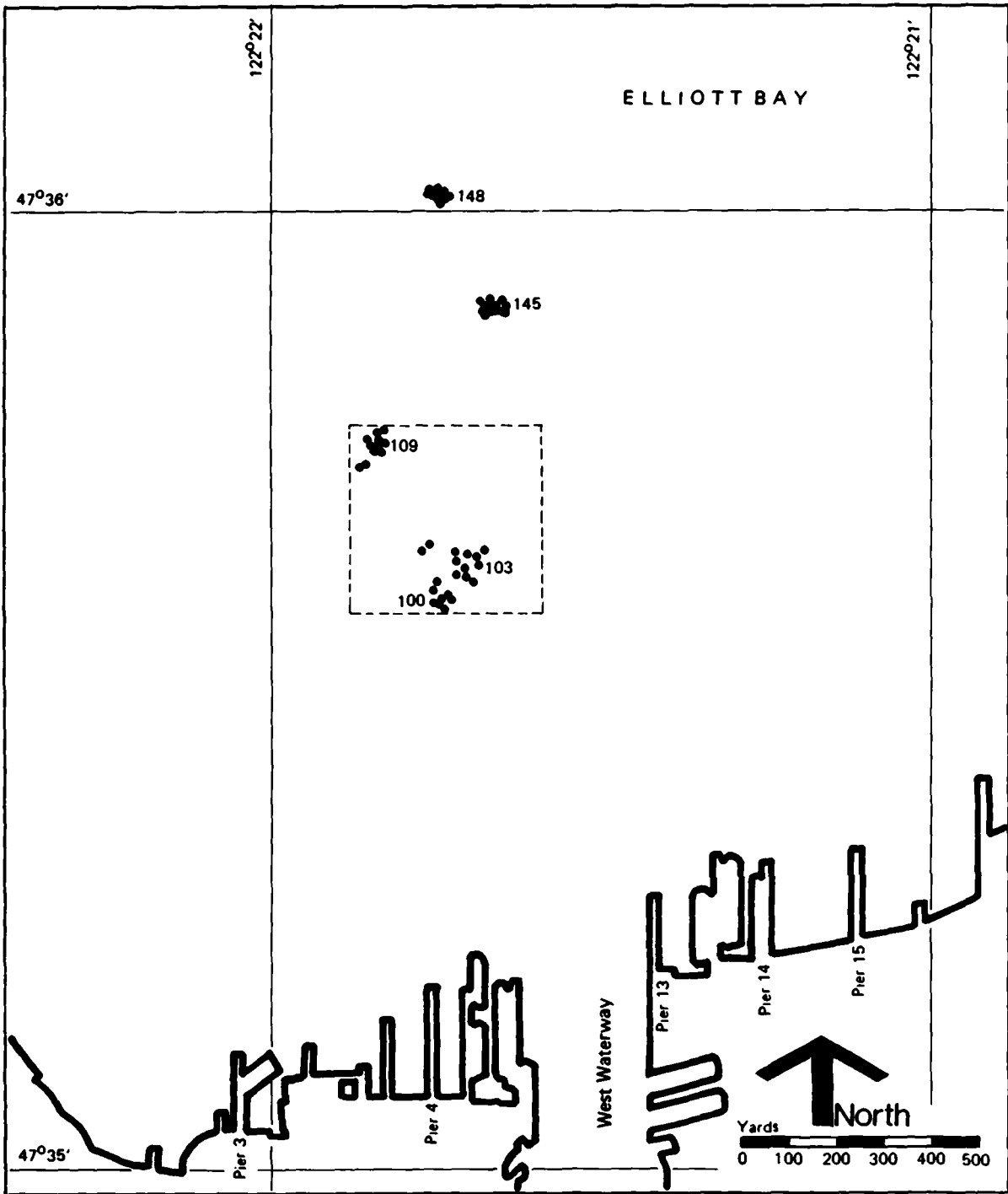

Figure 14. Station Locations (October 1979 Cruise), Grab Samples for PCB Content of Biota



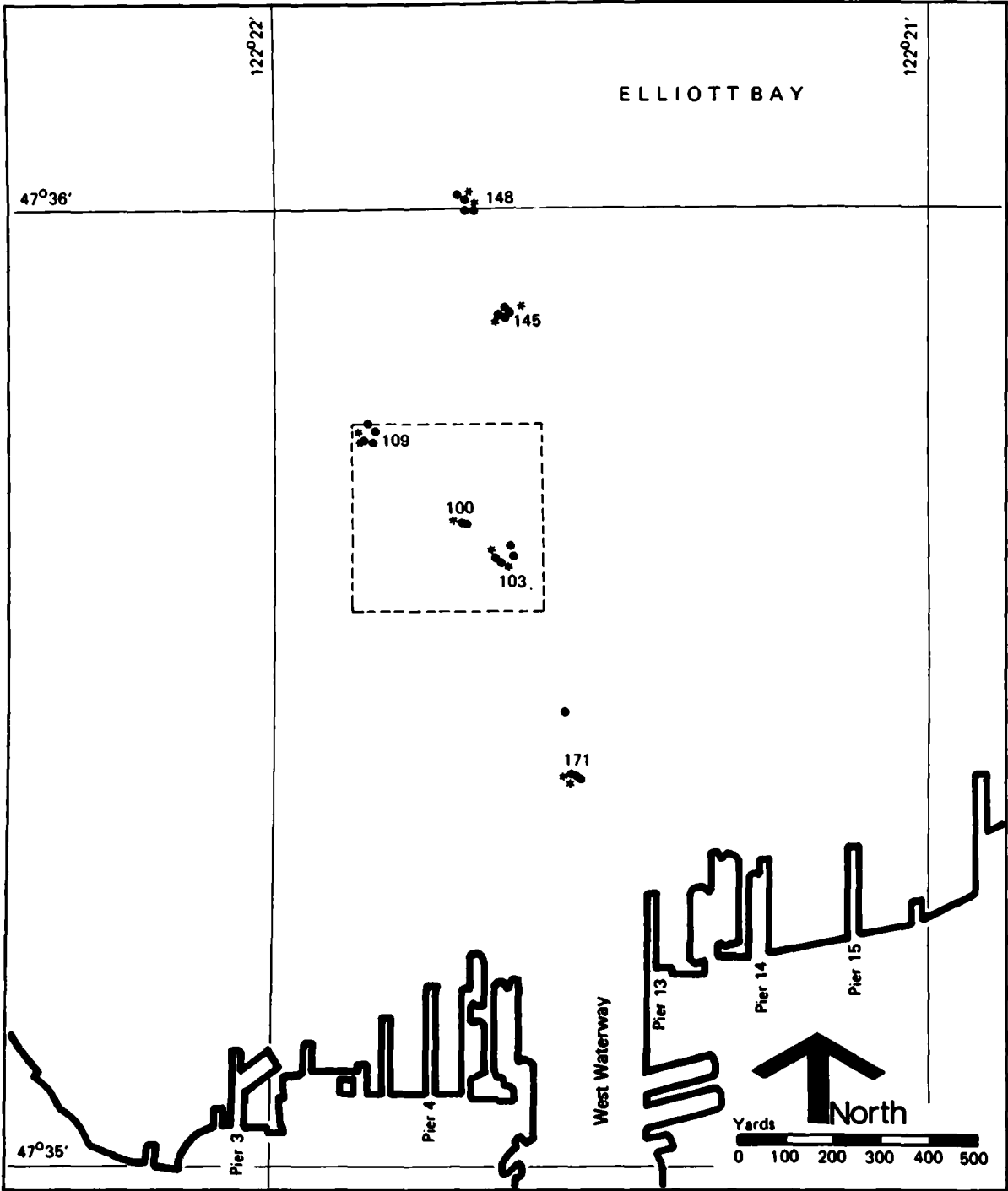

Figure 15. Station Locations (October 1979 Cruise), Water Samples for PCB Content of Water • and Suspended Particulate Matter and Hydrocasts\*

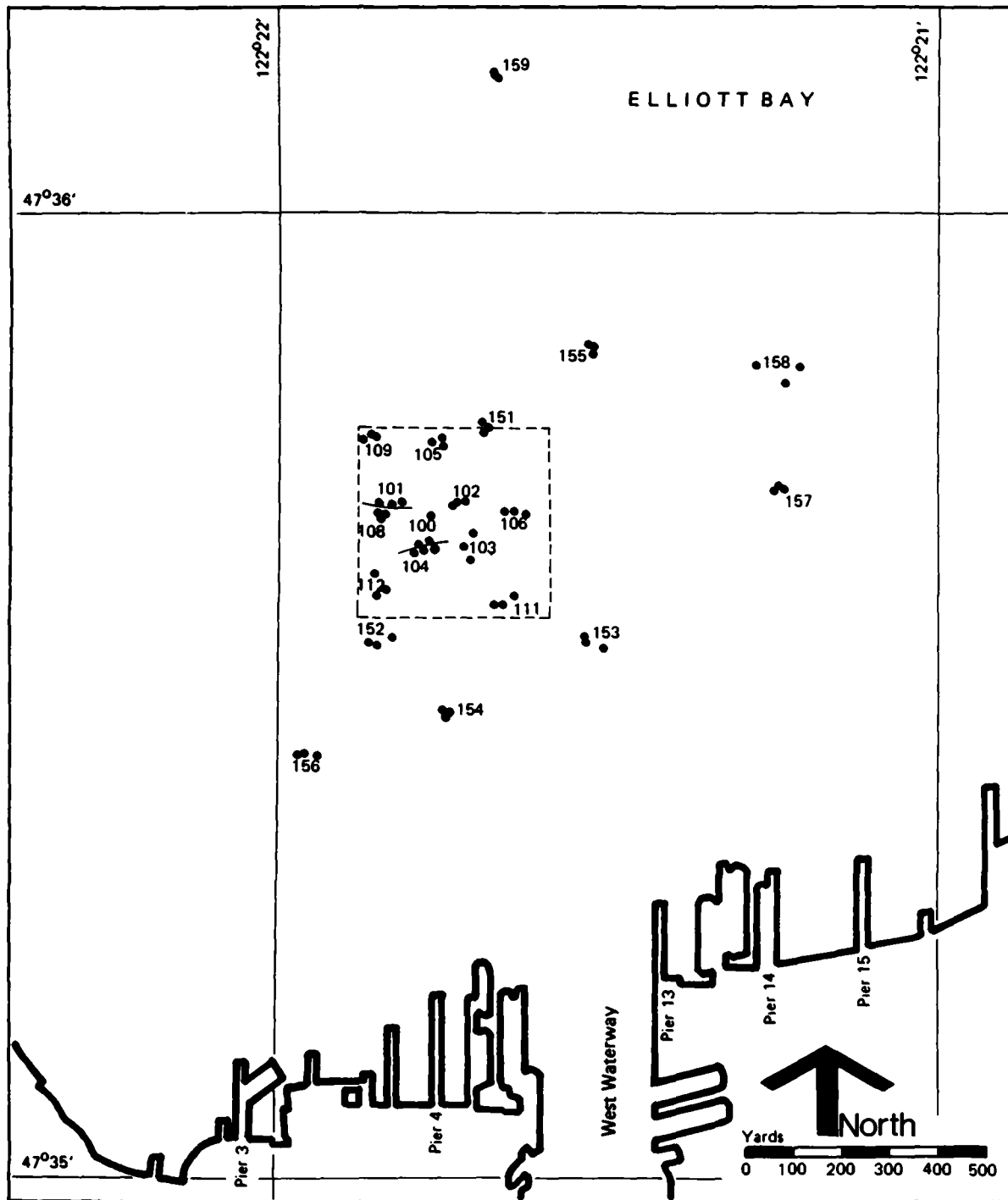

Figure 16. Station Locations (May 1980 Cruise), Grab Samples for Benthic Fauna Characterization

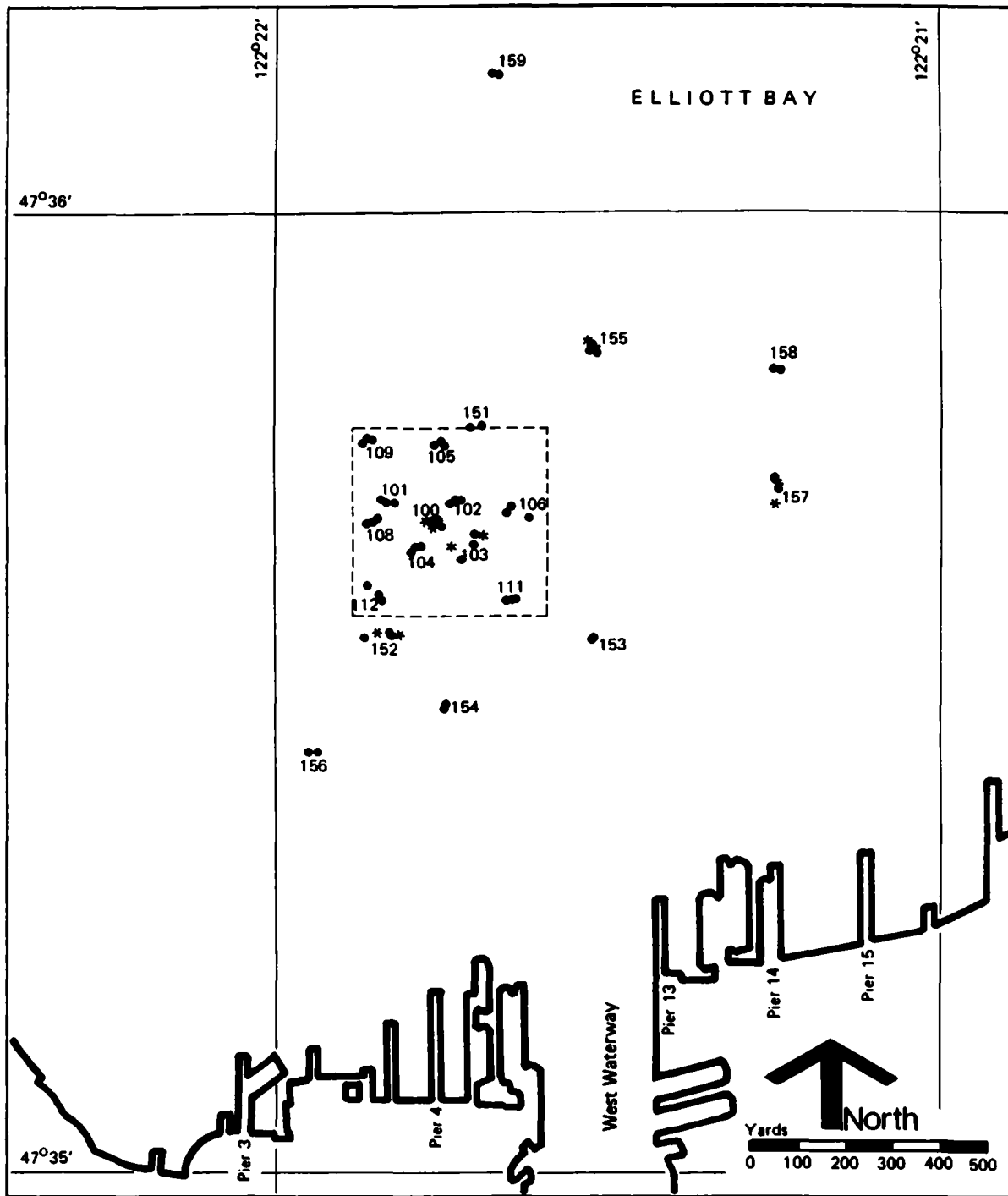

Figure 17. Station Locations (May 1980 Cruise), Gravity Cores for Grain Size • and Interstitial Water Analysis \*

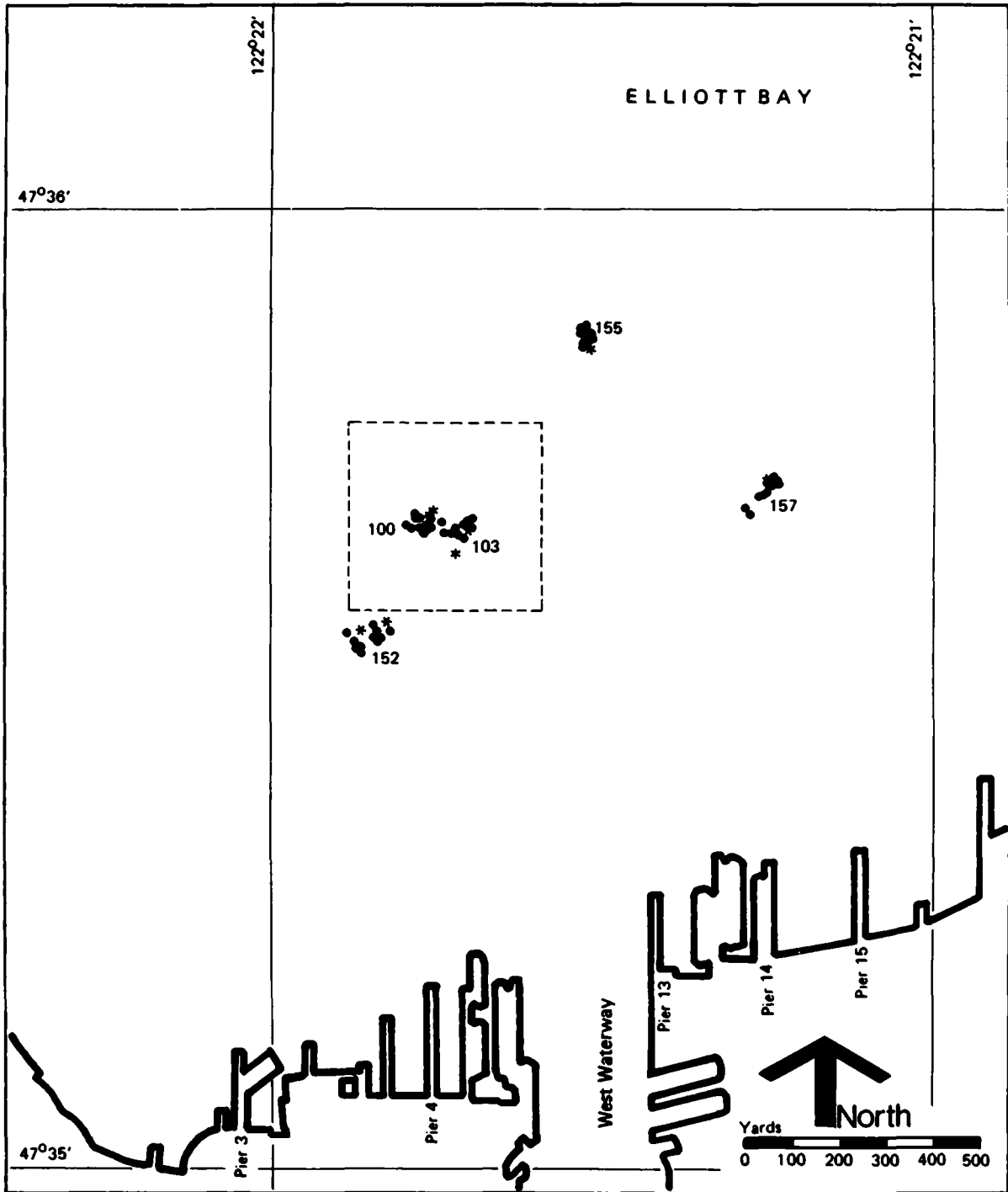

Figure 18. Station Locations (May 1980 Cruise), Samples for PCB Content of Sediments \* and Interstitial Water•

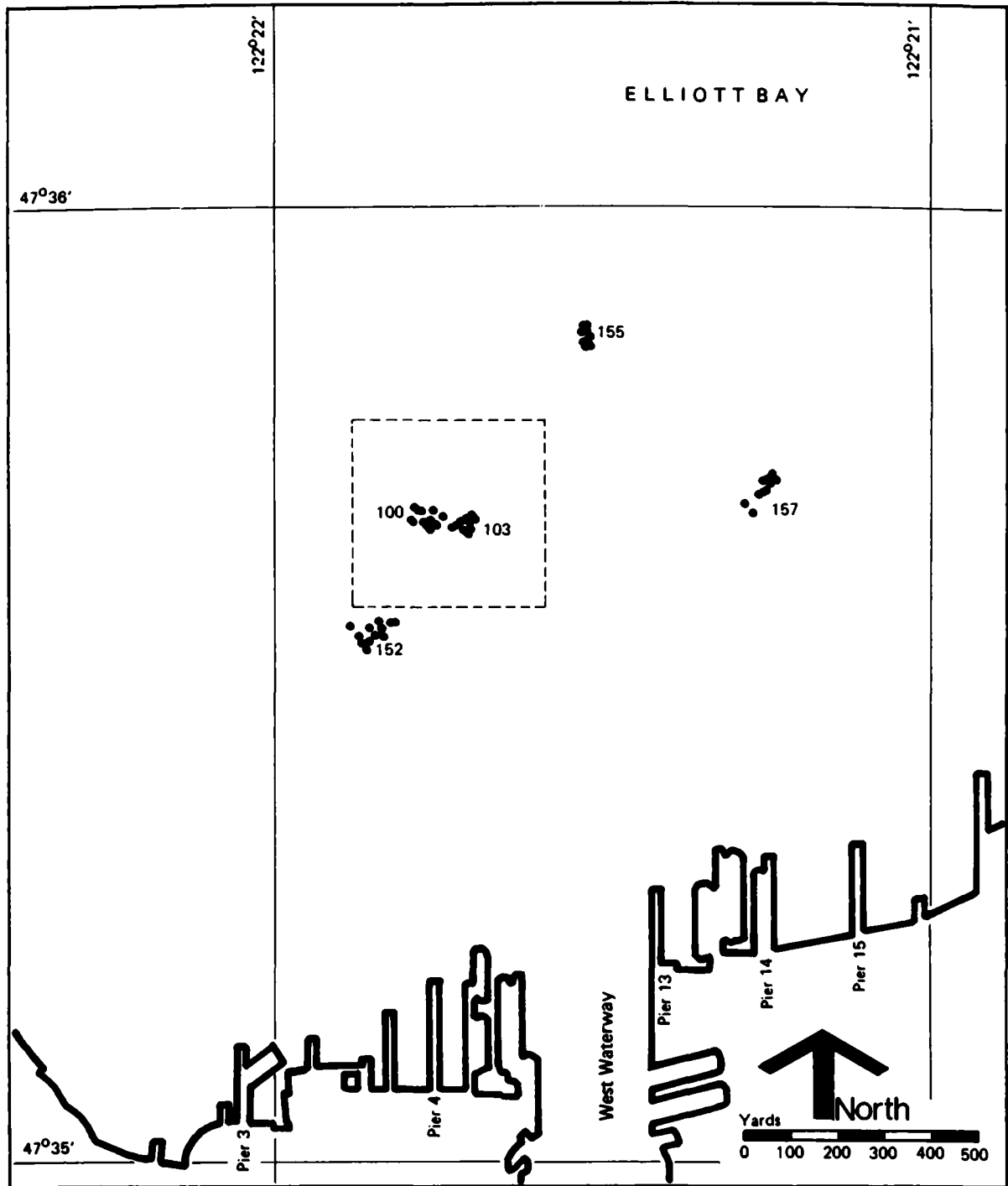

Figure 19. Station Locations (May 1980 Cruise), Grab Samples for PCB Content of Biota

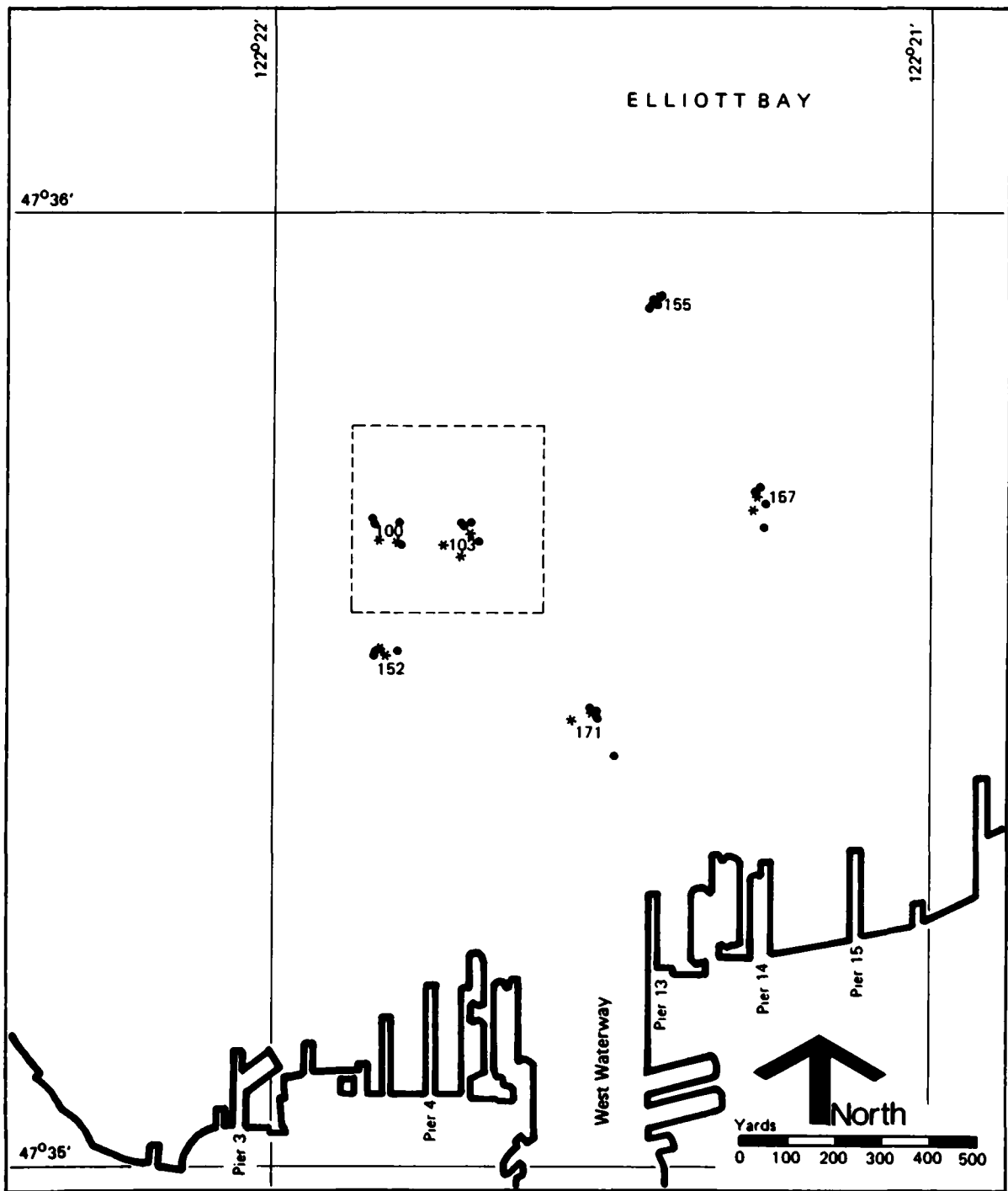

Figure 20. Station Locations (May 1980 Cruise), Water Samples for PCB Content of Water • and Suspended Particulate Matter and Hydrocasts \*

- B. Two standard 5-l polyvinyl chloride water bottle casts for the determination of salinity, temperature, nutrients, and dissolved oxygen. Each hydrocast consisted of five bottles located at the surface, 5 and 15 m, and at 10 and 1 m above the bottom.

The additional stations where only water was taken, located near the mouth of the Duwamish River and east of Duwamish Head, were selected to sample any river influence and Puget Sound background water, respectively.

At the other 15 stations in each cruise, three grabs for benthic fauna characterization and two or three gravity cores for textural analysis were collected. The stations within the grid were reoccupied throughout the study; therefore, the triplicate cores collected provided a statistical basis for determining temporal trends. Stations outside the original grid were not reoccupied; only replicates were collected to determine the variability at those stations and to characterize the background sediments.

### Shipboard Procedures

#### Sediments for PCB and texture analyses

All gravity cores collected for PCB and sediment texture analyses were extruded into a wooden trough on deck. When PCB samples were taken, the trough was lined with aluminum foil to avoid contamination.

Each core was processed on deck as follows:

- A. The core was extruded into a trough.
- B. The core was then split in half lengthwise.
- C. The core length was measured and a physical description of the core was recorded. This description included items such as overall length, color and texture variations and the depth at which these changes occur in the core, odor, and any unusual characteristics.
- D. Locations of subsamples (horizons) were determined and recorded, and the core was cut with a stainless steel spatula.
- E. Subsamples for textural analysis were placed in polyethylene bags and sealed to prevent water loss. These were placed in cold storage (4°C) until analyzed.
- F. Subsamples for PCB analysis were placed in precleaned glass jars, covered with aluminum foil, and capped. These samples were frozen until analyzed.

During the reconnaissance cruise, the subsample locations were determined by structural horizons indicated by changes in color or texture. Where no horizons were observed, subjective cuts were made. In general, three horizons were chosen in each core. The rationale for selecting subsamples was changed during the other cruises. Subsamples for PCB analysis included horizons of approximately 0 to 3 cm, 3 to 6 cm, 6 to 10 cm, 10 to 15 cm, and 15 to 25 cm (or end of the core) for all cores. The depths of the PCB subsamples were slightly changed at times to sample structural horizons. Subsamples for textural analysis were still determined by structural horizons with the exception that horizon 1 (top section of the core) was not to exceed approximately 5 cm. Cuts were made to coincide as much as possible with horizons used for PCB samples. In general, three subsamples for textural analysis were taken.

The core descriptions and horizon intervals for each core are presented in Appendix B.

#### Macrofauna samples

Biological samples for benthic fauna characterization were collected at all stations during all four cruises. Initially, a Smith-McIntyre sampler was used but it would not trip in the soft substrate of the disposal site. Therefore, all samples were collected with a cable-and-pulley rigged van Veen grab sampler with a maximum capacity of 20 l and a sampling area of  $0.1 \text{ m}^2$ . The sampler was lowered to the bottom at a velocity of approximately 2 m/sec. Grab volumes averaged 16 l for the February cruise, 14.4 l for the May 1979 cruise, and 15.1 l for both the October 1979 and May 1980 cruises. Each sample was processed on board ship in the following manner:

- A. Samples were carefully emptied into metal trays. Observations of color, odor, layering, percent wood, percent rocks, and sediment texture were recorded.
- B. The sample was emptied into a calibrated bucket and the volume of the sample was recorded.
- C. The sample was then emptied directly into a sieve or into another bucket, to be sieved later.



- D. The sample was sieved through a 1 mm mesh sieve using seawater from the ship's pump until all material finer than 1 mm passed through the sieve.
- E. The residue was transferred to 1 l jars. The jars were filled approximately two-thirds full with residue, and preservative was added immediately to fill the jar (see Quality Assurance discussion). The preservative composition was:
- Formaldehyde 37% Analytical Reagent: 2,000 ml
  - Distilled Water: 18,000 ml
  - Na<sub>2</sub>HPO<sub>4</sub>: 80 g
  - NaH<sub>2</sub>PO<sub>4</sub>: 130 g
  - Rose Bengal: 2 g

#### Benthic organisms for PCB uptake studies

The sampling procedure for collecting samples of benthic macrofauna for PCB analysis was basically the same as that employed for the quantitative macrofaunal study. Sediments were collected with a 0.1 m<sup>2</sup> van Veen grab sampler and sieved on board ship. For these samples, from 8 to 14 grabs were sieved through 2 or 1 mm mesh screens, whichever were available. As sieving proceeded, macrofauna that were uncovered were immediately transferred with forceps to precleaned glass jars containing filtered site water collected from 50 m by the water sample collection technique discussed below.

The organisms were then examined under a stereo microscope, identified, and different taxa transferred to separate precleaned jars with fresh, filtered site water. The jars were covered with aluminum foil, placed in crushed ice, and stored for at least 2 hr to allow purging.

After purging, each organism was rinsed, transferred to clean glass vials (or jars for larger organisms), sealed with aluminum foil cap liners, and frozen until laboratory analysis.

During the October 1979 and May 1980 sample collections, two to four of the grabs were sieved through the 1 mm mesh screens and all residue was transferred to pre-cleaned glass jars, with foil liners. Each night these samples were taken to the laboratory where technicians immediately removed the bivalves (primarily Axinopsida serricata and Macoma carlottensis); the bivalves were then transferred to pre-cleaned jars and immediately frozen for storage until analysis.

Neither the bivalves nor any other samples were exposed to any preservatives, plastic-ware, or nonsite water.

The above procedure was not followed exactly during the May 1979 cruise. All samples were separated into major taxa, stored refrigerated in site water, and taken to the laboratory after the cruise for final separation and identification. As a result, the samples were not frozen for 4 days after collection.

#### Interstitial water nutrients and sulfides

Interstitial waters were expressed from each of five sequential 5 cm horizons of sediment samples collected with either a gravity corer or, when corer penetration was insufficient, from subcores from a van Veen grab by using a nitrogen-operated nylon sediment press. Sediment was retained in the press by a prefilter (Whatman No. 1 filter paper) followed by a 0.45  $\mu$ m Millipore filter. A nitrogen overpressure of 10 to 60 psi was used to express the interstitial waters. For all samples, the first 5 ml of interstitial water collected was discarded. A portion of the next 5 to 10 ml collected was used for the determination of hydrogen sulfide with the balance quick-frozen in an acetone and dry ice bath and stored frozen for subsequent nutrient analyses. Hydrogen sulfide was determined colorimetrically by a modification of the method of Cline (1969). Samples were fixed on board immediately after collection, including preparation of standard curves. Final colorimetric analyses were performed each night in the laboratory. This determination was for the hydrogen sulfide (total  $H_2S + HS^- + S^=$ ) soluble in the interstitial waters and gave no indication of the total

reduced sulfur in the sediments which may have been present as precipitated metal sulfides, elemental sulfur, or as sulfur in an oxidation state intermediate between sulfate and sulfide.

#### Interstitial water PCB samples

Samples for the analysis of PCB residues in the interstitial water were collected from the upper 2 cm of the van Veen grabs. During the May 1979 cruise, two separate grab samples were collected at each sampling site, and approximately 1 l of sediment from each was transferred to solvent-cleaned jars with a metal spatula. Due to the high variability in the PCB levels in the sediments noted in the February and May 1979 data (see Results Section), interstitial water samples in October 1979 and May 1980 were collected as approximately equal aliquots from each of the first eight grabs taken for the PCB-biota samples. The first four sediment aliquots were combined to form replicate one, and the next four formed replicate two.

For each cruise, all samples were transferred each night to a refrigerator and stored until the cruise ended. As soon as practicable, the interstitial waters were separated from the sediments by centrifugation and subsequent filtration through precombusted glassfiber filters. The water fractions were stored in glass jars under hexane, while the sediment residue was frozen until analysis.

#### Water and suspended particulate matter samples

On the May 1979 cruise, water and suspended particulate matter (SPM) samples were collected by the same procedure employed during the original DMRP study (Pavlou et al., 1978). Replicate samples of water were collected at 1 and 10 m above the bottom at each site using a "beer keg" stainless steel sampler. On board, a 2 l aliquot for SPM mass determination and a 3.5 l aliquot of water for PCB analysis were removed from each sample. The remainder (approximately 46 l) was filtered by suction through precombusted glassfiber filters. The 2 l aliquot was filtered on board by suction through a 0.45-micron Nucleopore membrane filter. The 3.5 l aliquot was transferred from the sampler to a solvent-cleaned gallon jug via a teflon and metal tube. Approximately 100 ml of hexane was added to the water sample immediately after collection.

The SPM-PCB filters were placed in solvent-rinsed glass jars with aluminum foil cap liners and stored frozen until analysis.

For the October 1979 and May 1980 collections, a new water/SPM sampler was constructed to overcome three major shortcomings of the beer keg system:

- A. The beer keg was open when it entered the water, which may have allowed contamination of the sampler by surface film material.
- B. The port openings of the beer keg were small relative to the whole diameter, which may have resulted in significantly diminished flushing.
- C. The SPM collection system, which required suction filtration of large water volumes, was unwieldy and required considerable operator attention.

The new system, with a capacity of 25 l, consisted of a heavy-wall stainless steel pipe section with a stainless steel and teflon ball valve mounted on one end and a one-way air relief valve in the other. The sampler was winched to the desired sampling depth closed and empty to avoid both surface film contamination and flushing problems. At depth, the ball valve was opened by messenger from the surface, the sampler was filled, and the valve was closed prior to recovery.

Once on board, the filter holder (with a precombusted glassfiber filter) was attached directly to the sampler via a Swagelok quick-connect fitting and the sample was forced through the filter by 15 psi nitrogen. Filtered water samples were then collected directly in the glass jugs from the effluent of the filter holder and treated as before. Samples for the determination of concentrations of SPM (2 l) were collected prior to attaching the large glassfiber filter holder and filtered through 0.45-micron Nucleopore filters as in the May 1979 samples. The large glassfiber filters were stored frozen as before.

During the entire operation, the samples for PCB analysis contacted only stainless steel and a minimal teflon gasket area.

#### Bathymetric Data Collection

Detailed bathymetric surveys were conducted by the U.S. Army Engineer District, Seattle, in December 1978 and August 1979. East-west transects were taken throughout the original grid area at 15.2 m intervals. Depths were recorded at 7.6 m intervals along the transects.

### Current Meter Deployment

In order to determine the stability of the disposal mound, measurements of velocity, salinity, temperature, transmissivity, pressure, and bottom photographs were taken near the disposal site. On 17 May 1979, one array of six Aanderaa current meters and an SDS (Sediment Dynamics Sphere) tripod system from the University of Washington were deployed in the study area. The following equipment was mounted on the tripod:

- A. A Savonius rotor current meter located 1 m above the bottom.
- B. A transmissometer.
- C. A camera mounted to take bottom photographs.
- D. A pressure sensor.

The six Aanderaa current meters were located at 2, 6, 10, 14, 23, and 36 m above the bottom. Due to heavy ship traffic in the area, no current meters or flotation buoys were located within 20 m of the surface. The current meter array and tripod were located about 30 m apart in a relatively flat area just north of the original grid.

The instruments were recovered on 26 June 1979, having been in the water for 40 days. Several equipment problems occurred, resulting in the loss of some data. The current meter on the tripod did not record any information. One of the Aanderaa current meters was lost. Three of the remaining current meters appeared to have been tangled, and, thus, although current records were obtained, they were questionable and were disregarded. The bottom photographs were destroyed during lab processing.

The data judged to be valid consisted of:

- A. A complete record of pressure, showing tidal fluctuations.
- B. Two complete records of current velocity taken at 2 and 28 m above the bottom.
- C. Two records of salinity and temperature measured at 2 and 28 m above the bottom.
- D. A complete transmissometer record taken approximately 20 cm above the bottom.

The second deployment on 8 August 1980 consisted of one array of four Aanderaa current meters and the SDS tripod system. The tripod contained all of the equipment previously listed and an attached Aanderaa current meter to provide current speed but not direction. The instruments were recovered after 26 days. The current meter on the tripod and

the salinity and temperature sensors on the top Aanderaa current meter did not function. The retrieved data consisted of:

- A. A complete record of pressure, showing tidal fluctuations.
- B. Four complete records of current velocity, measured at 15, 22, 37, and 42 m above the bottom.
- C. Another record of current speed (no direction) at 3 m above the bottom.
- D. Four complete records of salinity and temperature measured at 3, 15, 22, and 37 m above the bottom.
- E. A complete transmissometer record taken at approximately 20 cm above the bottom.
- F. Bottom photographs taken at 30 minute intervals for 8 days.

### PART III: LABORATORY PROCEDURES

#### Sediment Texture Analyses

Sediment texture analyses were performed in accordance with the basic methods described by Folk (1964). The procedures used are described briefly below and are summarized in Figure 21.

Sediments were stored at 4°C in sealed polyethylene bags until analyzed. Samples were homogenized and quartered to yield an approximately 30 g aliquot. Approximately 10 g of this was used for determining percent water and percent total organic carbon. Approximately 20 g was used for grain-size analysis.

The subsample used for water and organic carbon content was placed in a tared beaker and weighed. It was then dried, desiccated, reweighed, and percent water calculated. Approximately 40 ml of H<sub>2</sub>O<sub>2</sub> was then added to the sample in 10 ml aliquots. The sample was again dried, desiccated, reweighed, and percent total organic carbon of the dried sample was calculated.

Distilled water and 10 ml of H<sub>2</sub>O<sub>2</sub> were added to the subsample used for grain-size analysis. The sample was allowed to sit for 12 hr and was then wet sieved thru a 4  $\phi$  ( $\phi = -\log_2 D$ , where D = diameter in millimeters; e.g., 4  $\phi = 0.0675$  mm) screen. The material passing thru the screen was collected in a 1 l settling cylinder. The residue on the screen was dried and sieved at 1/4  $\phi$  intervals from the largest fraction present to 4  $\phi$ . Any material passing through the 4  $\phi$  screen was added to the settling cylinder. When weighing the gravel and coarse sand fractions, notations were made of the approximate percents of wood, coal, and shell fragments present. Observations of other substances such as fruit pits and seeds were also noted.

Dispersing agent and distilled water were added to the residue in the settling cylinder to make 1 l. Sodium hexametaphosphate (about 0.5 g/l) was used as the dispersing agent. Standard pipette techniques were used to analyze the silt and clay fractions. Silt was measured in 1/2  $\phi$  intervals from 4.5 to 8  $\phi$  and clay was measured in 1  $\phi$  intervals from 9 to 12  $\phi$ . The 12  $\phi$  fraction contained all material

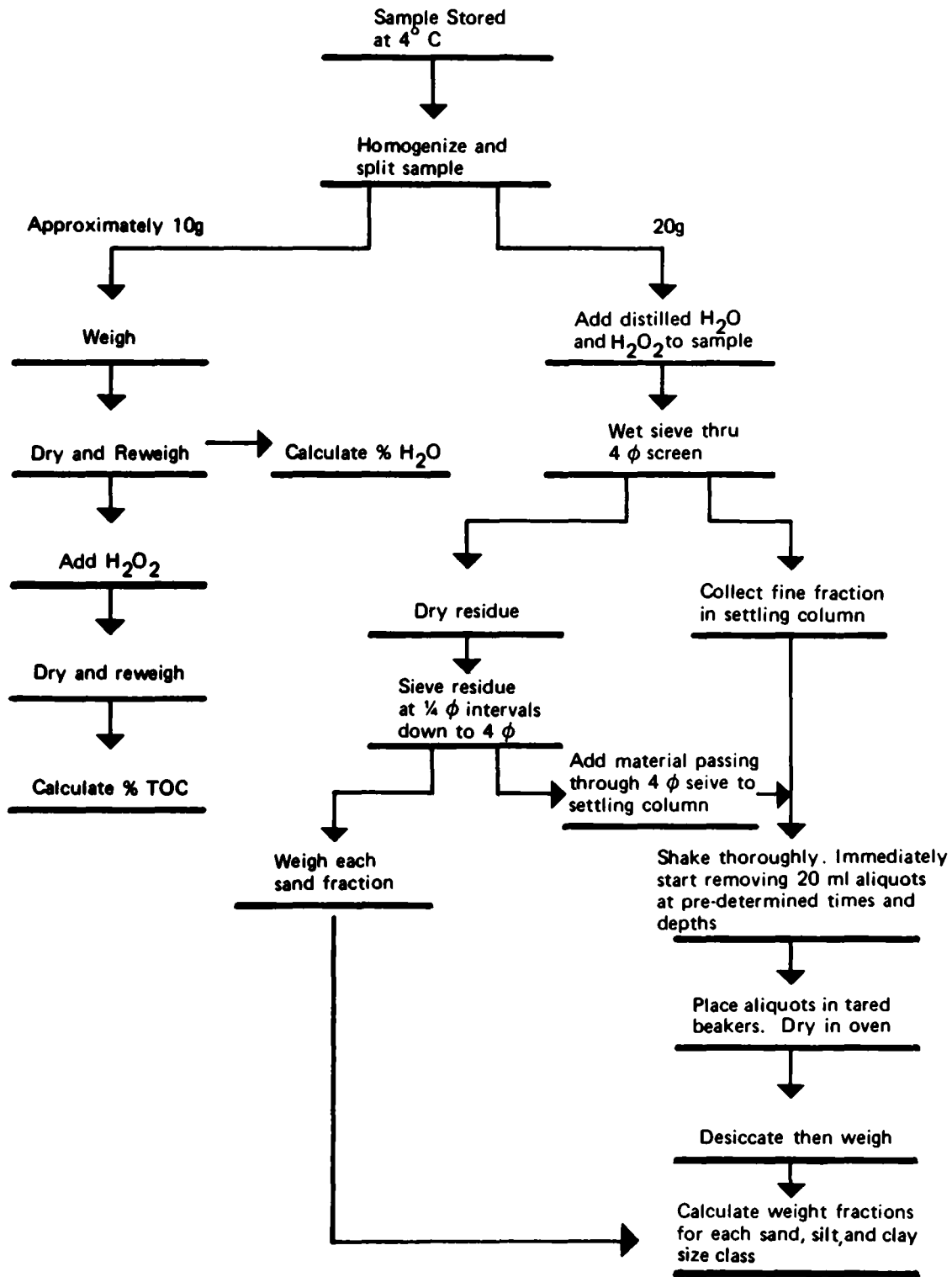

Figure 21. Flow Diagram for Sediment Texture Analysis



finer than 11  $\phi$ . Wadell's correction for nonspherical particles was applied to Stokes' law when calculating settling velocities (Krumbein and Pettijohn, 1938).

Ten percent of the samples were analyzed twice. During homogenizing and splitting, two subsamples were taken and analyzed as two separate samples to provide an indication of how well samples were homogenized and of the consistency of the analytical techniques.

### Benthic Macrofauna Enumeration

#### Macrofauna enumeration

The laboratory biological protocol is summarized in Figure 22. Samples were taken to the lab after each cruise and stored at room temperature until analysis. Whole samples were again examined visually and characterized for residue composition by estimating the percent wood and percent rock composition. Results were recorded on bench sheets. Macrofauna were sorted from the samples under water on large trays into two groups: (1) polychaetes and other soft-bodied macrofauna, and (2) mollusca. All macrofauna were sorted further and identified to species, when possible, by taxonomists.

Individual macrofauna were blotted dry and wet weights measured to +0.5 mg.

Macrofauna from the reconnaissance cruise were sorted and archived in a glycerin-ethanol preservative. May 1979, October 1979, and May 1980 cruise macrofauna were further sorted into six groups for archiving: (1) Capitellidae; (2) Euclymeninae; (3) Crustacea; (4) one group including Cossura sp., Chaetozone setosa, Paraonella spinifera, Aricidea spp. and Prionospio cirrifera; (5) another group with other soft-bodied macrofauna; and (6) mollusca.

Identifications were made using a 10 to 70 power dissecting microscope for polychaetes, a 10 to 20 power microscope for molluscs, and a 40 to 1000 power microscope for identifying smaller structures. Identification keys for polychaetes and other invertebrates were from Hobson and Banse (In prep), Banse and Hobson (1974), Banse and Hobson (1968), Lie (1968), Hartman (1968), and Hartman (1969). Keys for mollusca identification were Quayle (1974), Rice (1973), Coan (1971), Griffith (1967), and Oldroyd (1924).

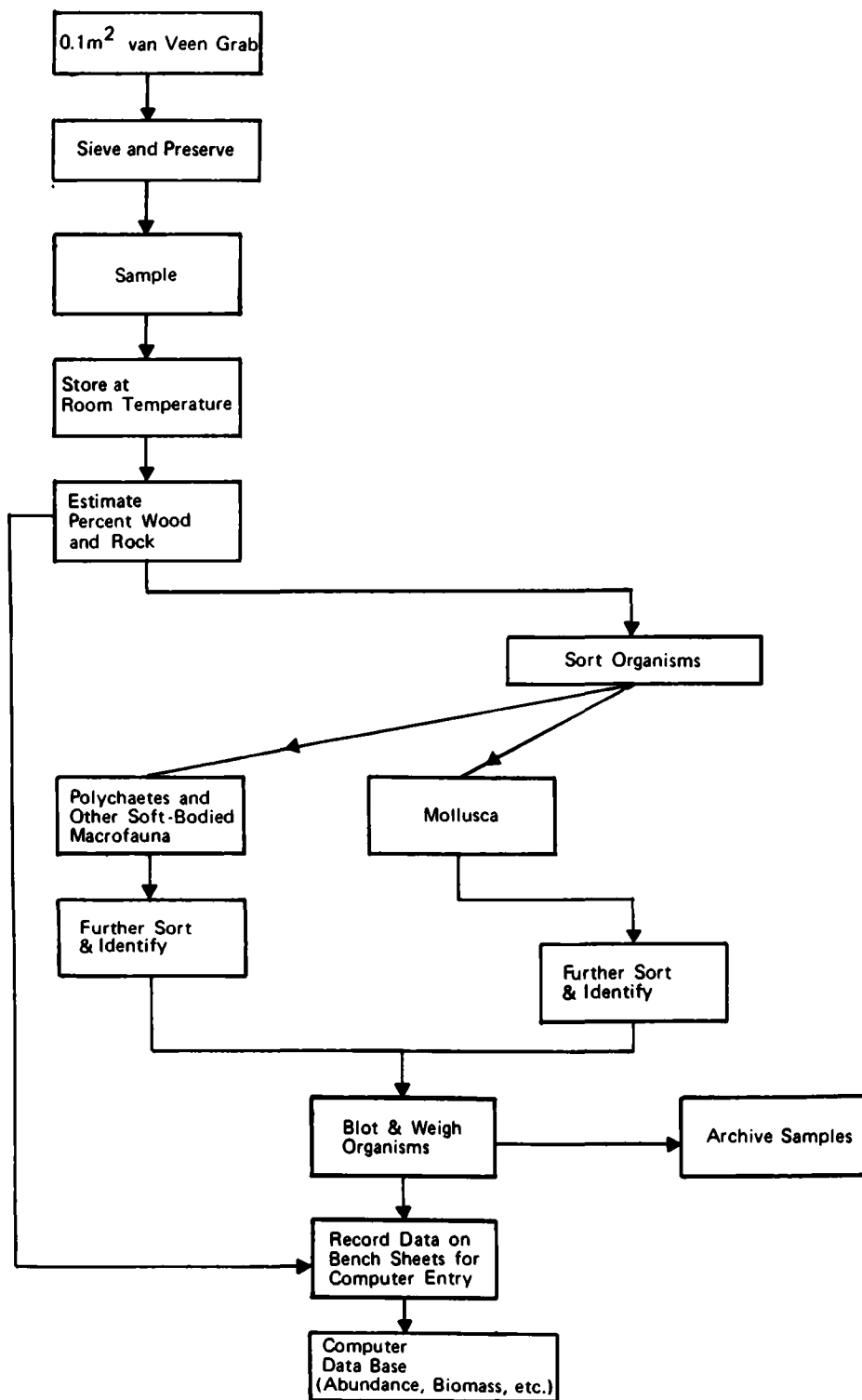

Figure 22. Flow Diagram for Macrofauna Enumeration Procedure

The level of taxonomic identification is represented by the master listing of the macrofauna which served as a bench sheet (Appendix C). Notable taxonomic differences between species reported by Harman and Serwold (1978) and used herein, are listed below:

<u>As Reported by Harman and Serwold (1978)</u>	<u>Reported Herein</u>
<u>Heteromastus filobranthus</u> and	
<u>Mediomastus californiensis</u>	Capitellidae
<u>Euclymene zonalis</u>	Euclymeninae

The Capitellidae, although combined for this report, represented several taxa including:

Barantolla americana  
Notomastus hemipodus  
Notomastus laterciens  
Heteromastus sp. (probably H. filiformis)  
Mediomastus sp. (probably M. ambiseta or M. californiensis)

The Amphipoda, all species also combined for this report, represented several taxa including:\*

Heterophoxus oculatus  
Bathymedon sp. 1 (possibly B. westwoodilla caecula)  
Bathymedon sp. 2 (possibly B. pumilis)  
Synchelidium cf rectipalnun  
Bruzellia sp.  
Byblis sp.  
Harpinopsis sp.  
Harpinia sp. (possibly H. schurini)  
Oedicerotidae  
Phoxocephalidae

#### Biological quality assurance

Ship-board. The following quality assurance measures were taken during biological sampling for all cruises, unless noted otherwise:

---

\* Dr. R. Diaz, Virginia Institute of Marine Science (VIMS), personal communication.

- A. Waterproof markers were added to the grab sample immediately after collection and these accompanied the sample residue through sieving to avoid sample mix-up.
- B. Field data sheets required logger's initials on each page to ensure data completeness.
- C. Metal trays were placed to catch residue spillage during residue transfer from sieves to sample bottles.
- D. Sample bottles were filled with residue approximately two-thirds full; water was drained through the sieve to prevent organism loss, and preservative was added. Bottles were inverted several times to ensure adequate mixing. During the reconnaissance cruise, many sample bottles were completely filled with residue before the preservative was added. This apparently introduced an error in the February cruise data since adequate fixation was hindered.

Laboratory. The following laboratory quality assurance measures were taken for all cruises, unless noted otherwise:

- A. Samples for all cruises were checked to ensure that each bottle was filled with preservative upon arrival at the laboratory.
- B. A reference collection of 48 polychaete taxa was submitted for independent verification by Dr. R. Diaz and associates at VIMS.
- C. A sample from the reconnaissance cruise (CR 1, STA 112, R 1) was independently identified by Dr. Diaz for comparisons with the data from the project taxonomists.
- D. Six blind samples were taken from the October 1979 cruise and submitted to the project taxonomists for a second round of identification and counting.
- E. The project taxonomists met with Dr. Karl Banse, University of Washington, to discuss identification of polychaetes and to obtain updates on taxonomic keys.

#### PCB Analytical Procedures

The basic analytical methodologies were comparable for all sample types and consisted of four sequential components: extraction, clean-up, gas chromatographic (GC) analysis, and quantitation, each supported by quality control procedures.

Detailed analytical procedures are provided for the following sample types:

- A. Water/Interstitial Water.
- B. Suspended Particulate Matter (SPM).
- C. Sediments.
- D. Invertebrates.

In the general scheme outlined earlier, only the first two steps, extraction and cleanup, varied among sample types. Once the final extract was prepared, GC analysis and quantitation were performed identically on all samples. Similarly, the same quality control program was applicable to all sample types.

Methods for the quantitative separation of the PCB residues from each of the four sample types of interest are presented in this section. These procedures were based on standard techniques, modified as necessary for specific sample types (Thompson, 1977; U.S. HEW, 1977). For convenience, the procedure for each type is presented as a separate section.

#### Extraction of water samples

A flow scheme of the extraction procedure for water samples is shown in Figure 23. It should be noted that the entire water sample was consumed in the analysis. No representative aliquots could be obtained.

Storage. The water samples were brought to the laboratory in 4 l glass jugs containing the sample (3.5 l) and approximately 100 ml of hexane. These samples were stored in the dark. The high concentrations of hexane were effective in retarding microbial growth and accumulated the majority of PCB residues prior to the initiation of the formal extraction procedure.

Extraction. A teflon-coated magnetic stirring bar (10 cm) was added to the sample/hexane in the original sample jug. The jug was placed on a magnetic stirrer and a strong vortex, sufficient to draw solvent to the bottom of the jug, was maintained for 20 min. Stirring was stopped and the phases allowed to separate (20 min). The hexane layer was drawn off by vacuum through a teflon tube into a 1 l separatory funnel, using the teflon stopper apparatus shown in Figure 24. This stirring-extraction procedure was repeated two times with additional 100 ml portions of hexane.

The quantity of water extracted was determined by emptying the contents of the jug, after the final hexane layer was removed, into a suitable graduated cylinder. Any water brought over into the separatory funnel was combined during this step. The volume was determined with a precision of at least  $\pm 20$  ml ( $= < 1$  percent). The water was then discarded.

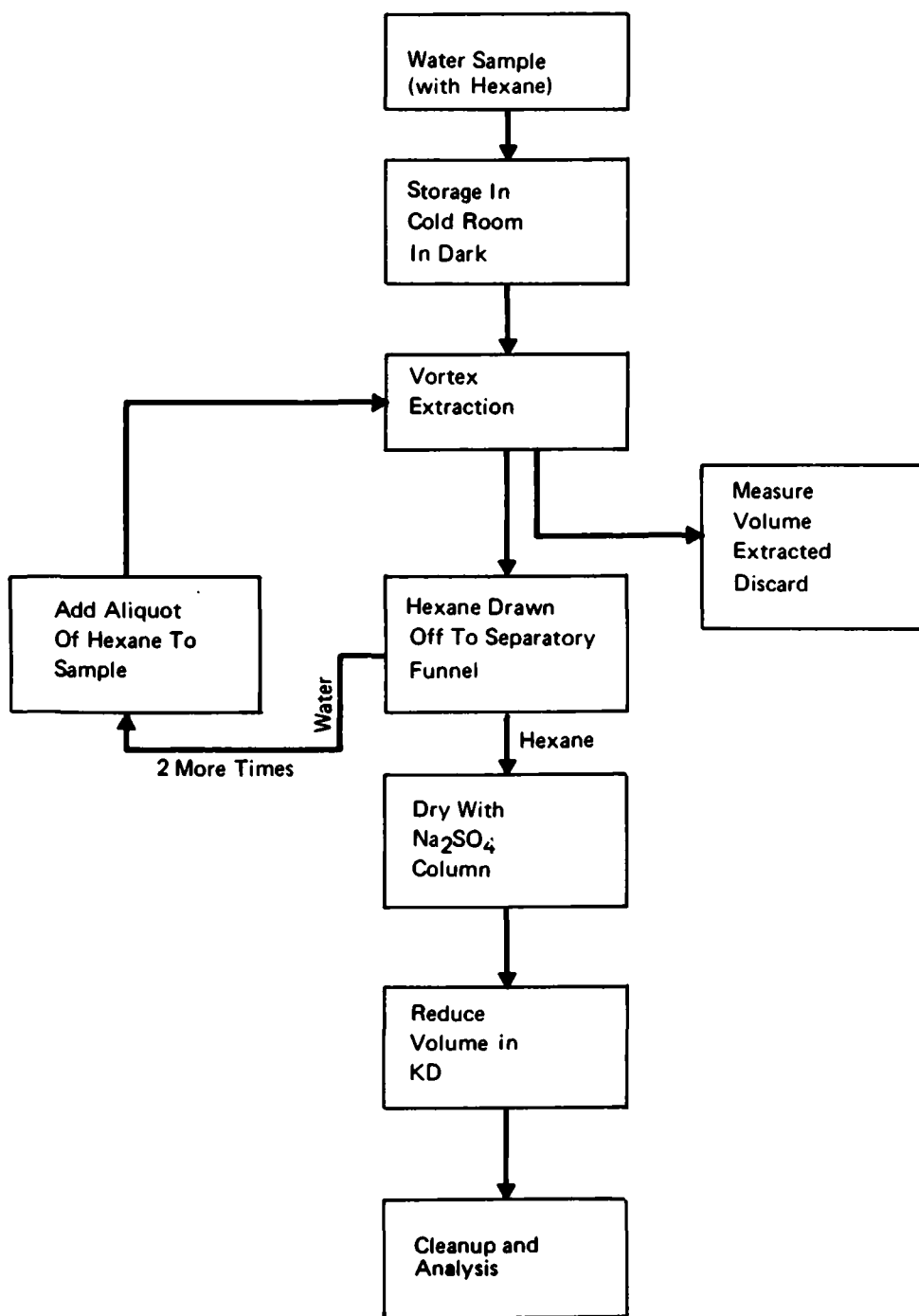

Figure 23. Flow Scheme of the Extraction Procedure for Water Samples

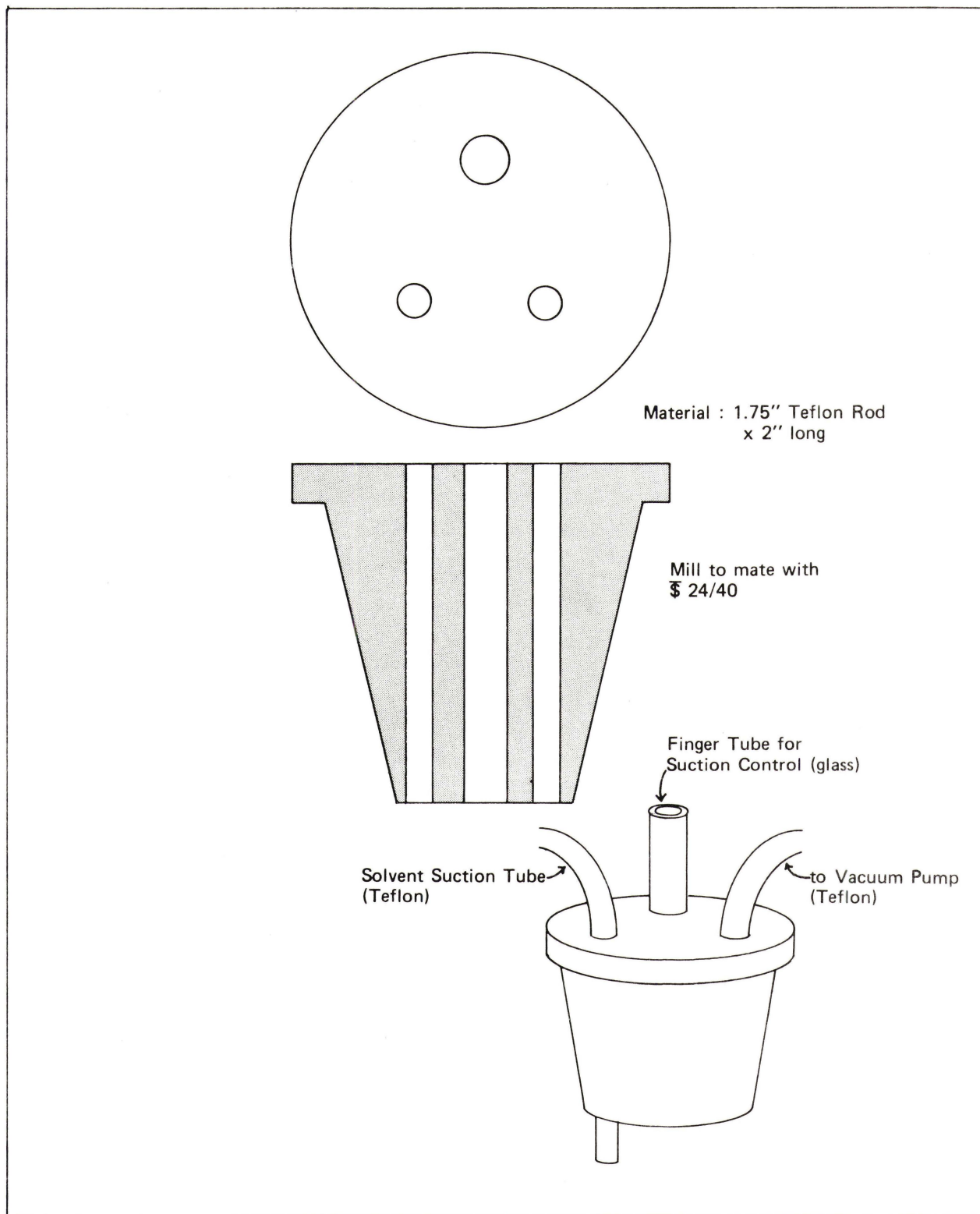

Figure 24. Projection and Perspective Drawings of the Teflon-Stopper Solvent Extractor Apparatus

The combined hexane extracts were eluted through a drying column of anhydrous  $\text{Na}_2\text{SO}_4$  (a large conical centrifuge tube with the tip cut off) with two 25-ml rinses of the separatory funnel into a one liter Kunderna Danish (KD) concentrator. The KD was fitted with a three-ball Snyder column and the extract volume reduced to approximately 5 ml on a hot water or steam bath. The cooled extract was transferred quantitatively to a glass-stoppered, graduated, conical centrifuge tube for storage prior to cleanup.

#### Extraction of interstitial water

A flow scheme for the determination of PCB's in the interstitial water is shown in Figure 25. Like the water samples, the entire sample was consumed requiring careful handling to prevent loss of the sample.

Storage. The sediment sample was stored in a refrigerator ( $5^\circ\text{C} - 12^\circ\text{C}$ ) after collection. The interstitial water was separated as soon as possible after collection.

Separation. The sediment sample was thoroughly homogenized. Aliquots were transferred to 300 ml stainless steel centrifuge jars and centrifuged for 10 minutes at 5000 rpm. The interstitial water was decanted and filtered through a precombusted glass-fiber filter and transferred to a clean jar. The sediment was returned to the original sample jar. Approximately 100 ml of hexane was immediately added to the interstitial water and thoroughly mixed using a teflon coated stirring bar for 10 minutes. The water fraction was then ready to be treated as a water sample, as described above. The sediment was frozen and treated as a sediment sample, as described below.

#### Extraction of suspended particulate matter

A flow scheme for the extraction of filtered samples is shown in Figure 26. As with water samples, each sample was entirely consumed in this analysis. No aliquots could be obtained and the limits of detectability usually required the use of all available sample.



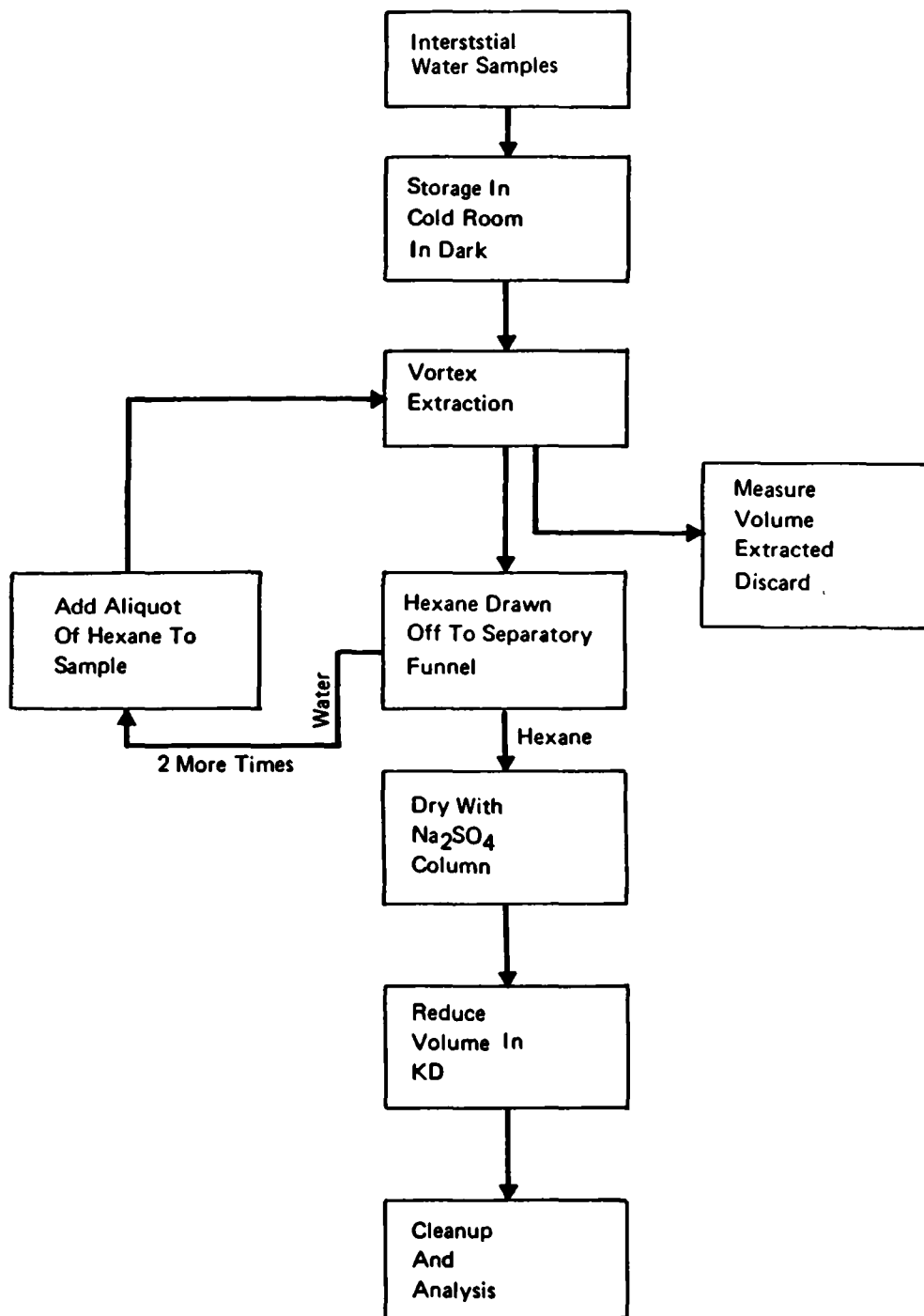

Figure 25. Flow Scheme of the Extraction Procedure for Interstitial Water Samples

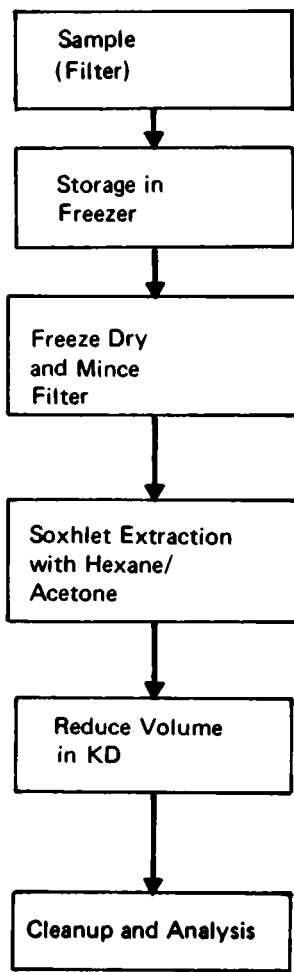

Figure 26. Flow Scheme of the Extraction Procedure for Filtered Suspended Sediments

Storage. Suspended sediment samples were collected on glassfiber filters and sent to the laboratory in glass jars. These samples were stored frozen while awaiting analysis. They are stable indefinitely if kept frozen and sealed.

Extraction. A set of samples was removed from the freezer, and the cap was removed from the jars and replaced with a clean, perforated (holes poked with clean tweezers or a small spatula) piece of aluminum foil. While still frozen, the samples were placed in a commercial freeze-drier with a large tray compartment and taken to dryness (usually 24 to 48 hr). When dry, the samples were removed from the drier, covered with fresh, unperforated aluminum foil, and recapped. More samples could be dried at one time than could be handled immediately in succeeding steps. Fully dried samples did not require refrigeration or frozen storage for at least 3 weeks.

Each filter was minced by hand and the small pieces transferred to a clean Soxhlet thimble of sufficient size that the entire filter could be added without packing and still be below the siphon level. The thimble was placed in the extractor and extracted with 2:1 hexane/acetone (v/v) for at least 18 hrs.

The cooled extract was transferred quantitatively to a KD concentrator that was equipped with a three-ball Snyder column, and the extract volume reduced to about 5 ml on a hot water or steam bath. The cooled concentrate was transferred quantitatively to a glass-stoppered, graduated, conical centrifuge tube for storage prior to cleanup.

#### Extraction of sediment samples

The flow scheme of the extraction procedure for sediment samples is shown in Figure 27.

Storage. Sediment samples were brought to the laboratory in glass jars and were stored frozen until analyzed. Frozen, the samples are stable indefinitely. Note, however, that freezing disturbs the natural sediment matrix; no work on interstitial water was performed on samples that had been frozen.

Extraction. The entire sample was thawed and carefully homogenized with a stainless steel spatula. An aliquot of approximately 20 g of wet

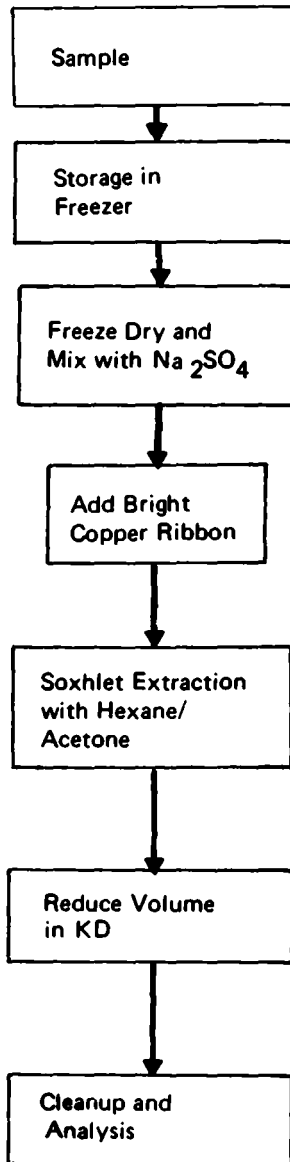

Figure 27. Flow Scheme of the Extraction Procedure for Sediment Samples

sediment was transferred to a tared Pyrex dish, weighed, and the dish covered with perforated aluminum foil. The aliquot was refrozen and freeze-dried in a commercial freezer-drier, following procedures specified by the equipment manufacturer. When completely dried, the sample was reweighed (difference between wet and dry weight gave a check on percent water determination). The dried sample cake was broken up with a spatula and transferred to a Soxhlet thimble. The empty dish was reweighed to confirm the measure of the sample taken for extraction.

The sediment was Soxhlet-extracted with 2:1 hexane/acetone (v/v) for at least 18 hrs. During the extraction, small balls (1 cm in diameter) of fine copper ribbon, brightened by dipping in a 10 percent nitric acid solution (washed with distilled water, then acetone), were added to the Soxhlet flask to remove elemental sulfur. The copper sulfide which formed was black. Sufficient copper was added so that some bright copper remained at the end of the extraction.

After extraction, the cooled solvent was quantitatively transferred to a KD concentrator. A three-ball Snyder column was added and the extract volume reduced to about 5 ml on a hot water bath. The cooled, concentrated extract was transferred quantitatively to a glass-stoppered, graduated, conical centrifuge tube for storage prior to cleanup.

#### Extraction of invertebrate samples

The flow scheme of the extraction procedure for the benthic invertebrate samples is shown in Figure 28.

Storage. The invertebrate samples were brought to the laboratory in glass jars and stored frozen until analysis.

Extraction. The sample was thawed, washed with distilled water, placed in a tared aluminum foil envelope, weighed, and freeze-dried. The dried sample was reweighed, transferred quantitatively to a Kuderna-Danish receiver, and minced. Approximately 5 ml of acetone was added and the sample refluxed for 15 min on a hot water bath. The solvent was cooled and decanted into a KD flask, and more solvent added to the receiver. This procedure was repeated a total of six times, extracting one time with acetone and five times with hexane, the solvents being combined in the KD flask.

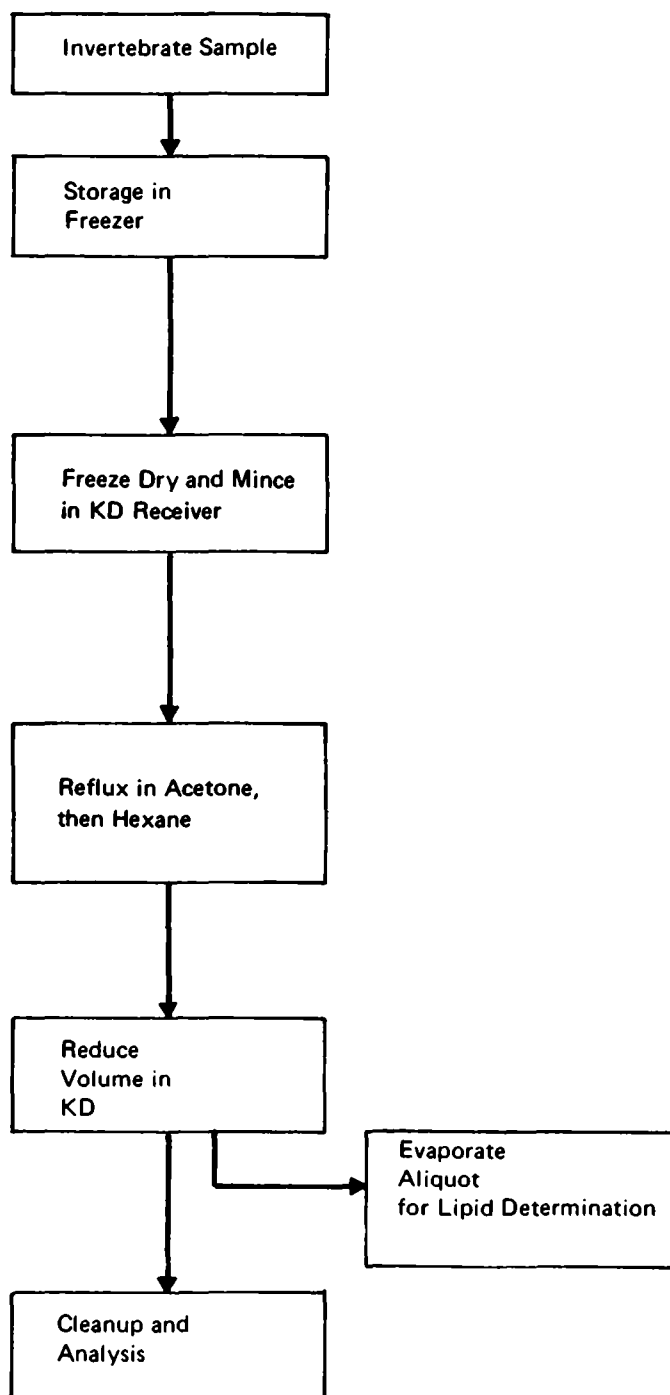

Figure 28. Flow Scheme of the Extraction Procedure for Invertebrate Samples

The volume of the combined solvents was reduced on the hot water bath to about 5 ml and transferred quantitatively to a graduated, glass-stoppered, conical centrifuge tube. A measured aliquot was transferred to a tared beaker, evaporated in a warming oven, and the beaker reweighed for lipid weight determination. The remainder was stored for cleanup and GC analysis.

#### Extract cleanup procedure

The sulfuric acid digestion technique is a simple and generally applicable procedure. PCBs are not affected, while many other organics and even some chlorinated hydrocarbon pesticides are completely eliminated. For these samples, this treatment alone was sufficient. The basic technique was presented by Murphy (1972).

The volume of extract in the centrifuge tube was reduced to about 2 ml, approximately 2 ml of trimethylpentane (TMP) was added, and the tube was placed back on the water bath until all of the hexane was removed.

An approximately equal volume of reagent grade concentrated sulfuric acid was added to the cooled TMP extract; the tube was stoppered and shaken carefully for 2 min on a vortex mixer.

After mixing, the phases were allowed to settle and react. The reaction was rapid and usually completed within 1 hr, but settling of all acid from the TMP phase took some time. The phases were allowed to settle by gravity for 12 hrs. Once good phase separation had occurred, the TMP layer was ready for injection into the GC. With reasonable care, the solvent was removed from the reaction tube directly with the GC syringe, avoiding penetration of the acid layer or touching the syringe to the sides of the tube.

#### Gas chromatographic analysis

After processing, the final TMP sample extracts were analyzed by electron capture gas chromatography (EC/GC). All analyses were performed on a Tracor MT-220 gas chromatograph equipped with two  $^{63}\text{Ni}$  high temperature electron capture detectors. The columns were 1.8 m by 2 mm Pyrex glass tubing packed with 1.5 percent SP-2250/1.95 percent SP-2401 on 100 to 120 mesh Supelcoport (Supelco, Inc., Bellefonte, Pa). As an

additional cleanup step, the tops of the columns were packed with approximately 2 cm each of 5 percent KOH and 5 percent NaOH on 80 to 100 mesh Chromosorb G AWDACS. The carrier gas was a mixture of 5 percent methane in argon. Spectra were recorded on a Hewlett-Packard Model 1922 strip chart recorder. Peak retention times and areas were determined by a Columbia Scientific Industries Model Supergrater-3 digital integrator. The PCB residues were characterized based on the following criteria:

- A. Only a limited number of organic compounds possess the specific chemical characteristics of PCBs, i.e., low polarity and resistance to both strong acid and alkali degradation (in the GC columns) required by the preanalysis processing of samples.
- B. Their retention times must agree with the corresponding peaks in known standards.
- C. Their relative spectral intensities (peak areas or heights) must resemble the pattern generated by known standards.

The components of the PCB mixtures were identified by comparisons of the retention times with those from serially injected mixed PCB standards. The concentrations of the chlorobiphenyls (CB) were determined by comparing the response of individual peaks via the spectral analysis technique described in detail in Pavlou et al. (1978). With this technique, the concentrations of the residues with the same degree of chlorination, N, could be determined, as well as the total residue content. This computational scheme was programmed into the Control Data Corporation 6400 computer system at the University of Washington for automatic data reduction. Detailed computational flow schemes and the program listing, including data inputs and outputs, were presented in Pavlou et al. (1978).

Prior to the final analysis, the raw data for all sample types were evaluated according to the procedures listed below:

- A. Confirmation of GC spectral patterns and initial quantitation.
- B. Internal consistency check of residue values.
- C. Preliminary synoptic assessment of temporal and spatial trends.

This procedure was adopted as a preliminary screening for flagging suspect data and detecting gross errors introduced by accidental mishandling of samples, incorrect spectral quantitation, inconsistencies in



replication, and contamination during analysis. In this manner, unreasonably large disparities from normal trends over the sampling periods and deviations of the data from historical and predicted behavior in the area could be identified prior to the initiation of statistical treatment and correlation analysis.

### Quality control

A rigorous quality control program is vital in maintaining accurate determinations. There are innumerable sources of error in a complex procedure such as PCB analysis which can introduce both random errors and biases, either toward greater or lesser values. The purpose of quality control is obviously to keep such problems at a minimum, to recognize and eliminate bad data, and to determine the probable precision of any set of measurements.

Procedural blanks were performed by running the entire analytical procedure as normally done, except without a sample. These blanks were included as a general check against contamination of any solvents, reagents, and/or glassware. At least one blank accompanied each group of each sample type analyzed. For larger sample sets, at least 10 percent blank analyses were performed. When an anomalous residue content was noted for a particular sample, the particular lot of glassware used in the analysis of that sample was immediately rinsed with hexane, the rinses collected and condensed, and the concentrate examined by EC/GC.

### Analytical Procedures for Sulfides, Nutrients, and Hydrographic Parameters

As mentioned above, sulfides in the interstitial waters were analyzed by the technique of Cline (1969). Reagents were added to the interstitial water immediately after the sediments were squeezed (on board ship) to fix the sample. Standard sulfide solutions and blanks were also prepared and analyzed on board ship to ensure comparable reagent characteristics and analytical procedures. Final colorimetric readings were performed each night on the day's samples in the laboratory.

Nutrients from both the interstitial water samples and from the water column samples were analyzed by standard autoanalyzer colorimetric

procedures. Nitrate was determined by the cadmium-copper reduction to nitrite. Reduced nitrate (nitrite) and natural nitrite were determined by the sulfanilamide/naphthylene diamine method (Armstrong et al., 1967). Orthophosphate was analyzed by the ascorbic acid/molybdate procedure, ammonia by the phenate method, and reactive silicate by the molybdate/oxalic acid/molybdate procedure (Strickland and Parsons, 1968). Oxygen samples were analyzed by the modified Winkler method (Carritt and Carpenter, 1966). Salinities were determined by inductive salinometer (Paquette, 1958). All nutrient, oxygen, and salinity determinations were performed by the Routine Chemistry Laboratory, Department of Oceanography, University of Washington, Seattle, Washington.

## PART IV: DATA PROCESSING

### Data Management

The data management scheme was divided into three segments: 1) data base planning and implementation, 2) data entry and verification, and 3) data analysis.

The Statistical Analysis System (SAS) (SAS Institute, 1979), a combined data base management and statistical analysis package, was selected for the SAS interactive and batch processing capabilities which met the requirements of the project.

The nature of the data and need for integration of several disciplines suggested a rectangular data base. The basic design was a chronological record for all variables with an ascending spatial numbering sequence for each sampling site. This design was implemented and tested with a small data set in preparation for all subsequent data.

The primary variables in the data base that formed the foundation were station number, day, month, year, local time, replicate number, horizon number, duplicate number, and sample type. These were common to all of the disciplines and allowed for nonsimultaneous data entry. SAS subsequently merged select data sets to form the primary working data sets.

Data submission, verification, and acceptance into the data base were continuous but sporadic. As analyses were completed and the raw data reduced, values were compiled into reasonable units and keypunched onto cards or keyboard-entered into the computer directly. The data were read, tabulated, and immediately returned for editing. After all edits to the initial data were completed, a SAS data set was constructed and a sorted tabular listing was generated and submitted to the analyst for final verification. Once the analyst verified the data, they were accepted into the segmented level of the data base where no integration of different data types was performed. After a sufficient volume of data was logged into the data base, merging the data sets was performed to create data sets that contained detailed spatial and variable value information. The three integrated data sets were categorized as biology, chemistry, and geology.

The physical oceanography data were handled separately on the CDC 6400 due to the large volume of data collected.

After inspection and editing of the data set, it was ready for processing. Canned programs were used to read and process the data into various forms amenable to further data reduction.

Once the data for an entire cruise was entered, verified, and placed into a data set, analysis began. Of the many features that SAS offers, the most frequently used were summary, nonparametric, and report writing. SAS generated formatted outputs for analysis by CLUSTAN and spatial autocorrelation, programs which are not readily available through SAS. When needed, SAS produced simple plots for interpretation. Examples of the many types of analytical procedures used follow in this report.

Due to the large volume of data generated, hard copies of the raw data tables are not included in this report. The data are available on magnetic tape from WES or on punched cards from URS Company, Seattle, WA.

## Data Analysis

### Geophysical studies

Three types of geophysical data were collected: bathymetric data, sediment texture data, and current measurements. The basic analysis of each data type is discussed herein. Further discussion of data analysis is included in Part V.

Bathymetric data analysis. The Seattle District provided the bathymetric data on punched cards. Canned programs were used to plot plan and perspective views of the topography in the disposal area. Differences in bottom topography between surveys were also calculated and plotted by the computer.

Sediment texture analysis. Weight fractions for each phi size class were calculated using an established computer program (FRACT, Marine Science Library, University of Washington). Another program (SEDAN) calculated the weight percent; percentages of gravel, sand, silt, and clay; the sand to mud ratio; and other statistical parameters such as mean and median phi, deviation (sorting), skewness, and kurtosis.

The data were analyzed in order to establish spatial and temporal trends in the grain-size data and to delineate the dredged material. Spatial trends were established by plotting the percent sand content and mean phi size of the surface sediments. Because of the large variability between some replicates of the same station, station means were plotted.

Since the sediments were poorly sorted, it could be misleading to only analyze statistical parameters. Sediment samples can have very different distributions but still have similar mean phi values or similar sand content. Therefore, the most abundant phi sizes were also examined. Several patterns emerged, and sediment types were defined based on patterns observed in the most abundant phi sizes. These sediment types were used in conjunction with chemical and physical data to delineate the dredged material and further define spatial trends in the sediment distribution.

Temporal trends were established by analyzing the changes in mean phi and percent sand through time at several locations within the disposal area. Because it was virtually impossible to reoccupy the exact same location and because the stations were spaced closely together, specific areas of the bottom were located within different stations on different cruises. Therefore, comparisons were not made strictly on the basis of station number. The location of each core collected within and just outside the original grid was plotted. Based on a subjective view of proximity, five groups were defined (see Part V). An effort was made to include at least three cores each from cruises 2, 3, and 4 in each group.

For each group, the mean and standard deviation of percent sand and mean phi were calculated for each cruise. Each group was examined for trends through time in mean phi size and percent sand using linear regression. For the five groups, the variability within each cruise was compared to the variability through time. The standard deviation was used as a measure of variability.

The results of these analyses are discussed in Part V.

Current measurements. The time series of individual current velocities were separated into mean and fluctuating components. The mean currents were obtained by filtering the time series with a Groves

39 hr filter to remove the tidal currents. The fluctuating part was characterized by the variance in the current meter records. These calculations were made using established programs at the University of Washington.

Based on measured values of daily maximum currents, the 1 yr extreme current was predicted as follows:

- A. Daily maximum currents were ranked from lowest to highest.
- B. Probability of a current occurring was defined as  $P = r/(n+1)$  where  $r$  = rank and  $n$  = sample size.
- C. Daily maximum currents were plotted versus probability. A least square fit line was drawn through each set of points.
- D. The 1 yr maximum current corresponded to the point on the line where  $r = n = 365$  or  $P = .9973$ .

A more complete discussion of the current meter data analysis is presented in Appendix D.

### Biological data analysis

Mapping. Two approaches to mapping the taxa abundances were used: 1) calculating mean values for each station's three replicates and manually producing geometric contour maps, performed for February and May 1979 cruises only; and 2) dividing the range of abundances for each taxa into discrete subsets and plotting individual replicates.

The second method is the more objective and was used for presentation of results in this report. Mapping for the May 1979, October 1979, and May 1980 cruises was performed using a plotting procedure from the SAS data base management system.

Cluster analysis. Cluster analysis was performed using the CLUSTAN (1C) computer program developed by Wishart (1975). The cluster analysis progressively groups stations (agglomerative) as entities (normal analysis) and considers each station unique to a group (exclusive). The station grouping is based on several attributes (polythetic); in this study, these attributes were the abundances and biomasses of taxa of benthic macrofauna. All attributes were species-total standardized (e.g., Boesch, 1977) prior to calculating dissimilarity indices. The Bray-Curtis Index was used to calculate the "distance" between stations. The Lance-Williams flexible beta combinatorial method was used to calculate distances between groups of samples (Boesch, 1977).

Species-total standardization is defined as:

$$Y_{ij} = \frac{X_{ij}}{\sum_k X_{ik}}$$

where

$Y_{ij}$  = the standardized value (e.g., abundance or biomass) of taxa  $i$  in sample  $j$ .

$X_{ij}$  = the raw value of taxa  $i$  in sample  $j$  at station replicate  $j$

$\sum_k X_{ik}$  = the total value of taxa  $i$  in all  $k$  samples

The Bray-Curtis coefficient is used to calculate a "distance" (or dissimilarity index) between all possible pairs of samples. This dissimilarity coefficient is defined as follows:

$$D_{ij} = \frac{\sum_{k=1}^n (X_{ki} - X_{kj})}{\sum_{k=1}^n (X_{ki} + X_{kj})}$$

where

$D_{ij}$  = "distance" between samples  $i$  and  $j$

$n$  = number of taxa

$X_{ki}(X_{kj})$  = standardized value (e.g., abundance or biomass) of taxa  $k$  in sample  $i$  ( $j$ )

A matrix of inter-sample distances ( $D_{ij}$ ) was formed by performing the above calculations on all pairs of sample replicates. The lowest value of  $D_{ij}$  was selected from the matrix and defines the initial linkage (sample combination), plotted on a dendrogram (e.g., Figure 29). A new matrix was formed by calculating distances between all sample pairs and considering the combined samples (above) as a single entity. This process of combining most-similar groups, and calculating a new

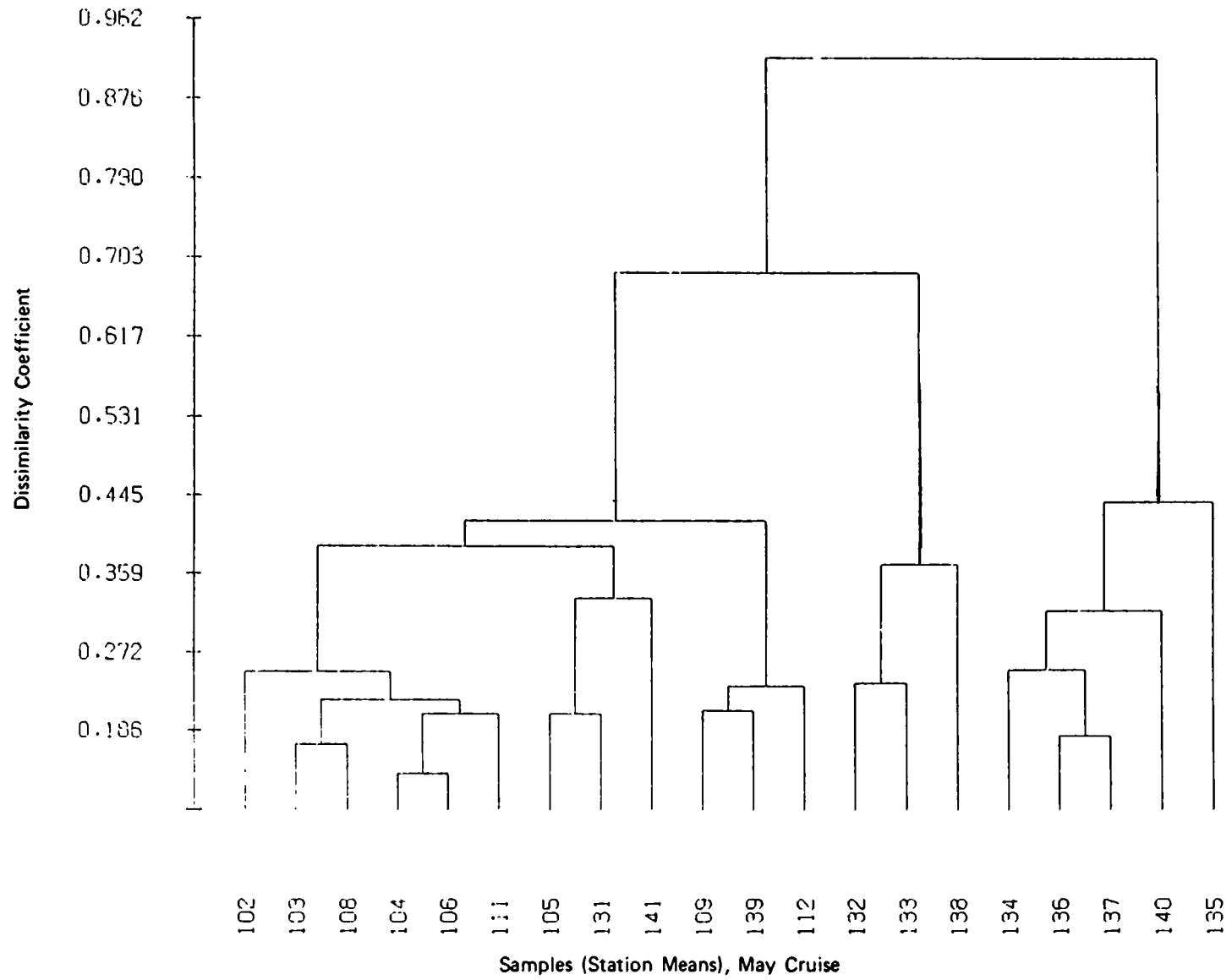

Figure 29. Typical Dendrogram Resulting from Cluster Analysis



distance matrix, was repeated until all samples were linked. The Lance-Williams method calculates distances between groups (formed of samples which have been linked) and is defined as:

$$D_{ij,h} = \partial_1 D_{ih} + \partial_2 D_{jh} + \beta D_{ij}$$

where

$D_{ij,h}$  = distance between sample h and group formed of samples i and j

$D_{ih}$  = distance between samples i and h

$D_{jh}$  = distance between samples j and h

$D_{ij}$  = distance between samples i and j

$$\partial_1 + \partial_2 + \beta = 1$$

$$\partial_1 = \partial_2 = 0.625 \text{ and}$$

$$\beta = -0.25$$

Boesch (1977) cited several marine ecological applications of flexible clustering including Stephenson et al. (1970, 1972, 1974), Williams and Stephenson (1973); and Boesch (1973).

Wilcoxon two-sample test. The Wilcoxon two-sample test is a nonparametric (distribution-free) method which tests the null hypothesis that two samples are drawn from the same population. The test was performed by using a subroutine of SAS.

The test was conducted by dividing the samples (i.e. station replicates) into two groups (a and b) as discussed in Part V. The abundances or biomasses for all samples were ranked from smallest to largest. The ranks assigned to samples from each group were individually summed and designated  $T_a$  and  $T_b$ , respectively.

The expected value of  $T_a$  [ $E(T_a)$ ] was calculated as follows:

$$E(T_a) = \left( \frac{n_a}{n_a + n_b} \right) \left( \frac{(n_a + n_b)(n_a + n_b + 1)}{2} \right)$$

where

$n_a$  ( $n_b$ ) = number of samples in group a (b)

Significance of the observed deviation of  $T_a$  from its expected value was tested by a Z statistic, which is approximately normally distributed (Steel and Torrie, 1960), and is calculated as follows (Hollander and Wolfe, 1973):

$$Z = \frac{[T_a - E(T_a)]}{\sigma_T}$$

where

$$\sigma_T = \sqrt{\frac{n_a n_b (n_a + n_b + 1)}{12}}$$

Spatial autocorrelation analysis. Spatial autocorrelation analysis was conducted for only the May 1979 cruise taxa abundances using a computer program developed by D. Wartenberg (Ecology and Evolution Department, State University of New York at Stony Brook). The test statistics calculated are Moran's I and Geary's c (Cliff and Ord, 1973). The general formula of Moran's I was:

$$I = \frac{\sum_{ij}^n w_{ij} Z_i Z_j}{W \sum_{i=1}^n Z_i^2}$$

where

n = number of samples

$Z_i = x_i - \bar{x}$ ;  $Z_j = x_j - \bar{x}$

$x_i$  = the abundance of the particular taxa (x) at station replicate i(j), and  $\bar{x}$  is the mean abundance of the particular species (x) for all station replicates

$w_{ij}$  = weight assigned the comparison of samples (station replicates i and j)

$$W = \sum_{ij} w_{ij}$$

The particular  $w_{ij}$  used for this report was recommended by Dr. P.A. Jumars and Mr. J.E. Eckman (Department of Oceanography, University of Washington) and is defined as:

$$w_{ij} = \frac{1}{(r_i - r_j + c)^2}$$

where

$r_i, (r_j)$  = distance of sample i (j) from the center of the original disposal grid

c = constant = 25 m

The general formula of Geary's c, as applied to the project data, is:

$$c = \frac{n-1}{2W} \frac{\sum w_{ij} (x_i - x_j)^2}{\sum Z_i^2}$$

with the same definitions as above for n,  $w_{ij}$ ,  $x_i$ ,  $x_j$ ,  $Z_i$ , and W.

The purpose of the constant (c) is to prevent  $w_{ij}$  from becoming undefined (i.e., 1/0) when samples lie exactly the same distance from the grid center.

I and c are most sensitive to inter-sample comparisons that are assigned the largest values of  $w_{ij}$ . With the weighting coefficient ( $w_{ij}$ ) as defined above, comparisons among samples that are similar distances from the center of the disposal grid will contribute most to I and c. Therefore, the null hypothesis of random dispersion of variate values (e.g., taxa abundances) among sample locations may be disproved ( $P < 0.05$ ) if samples that are similar distances from the center of the disposal grid tend to have similar taxa abundances.

Kendall tau-b correlation analysis. Kendall tau-b correlation analysis is a nonparametric method which tests for the significance of association between two variables. The test was performed by using a subroutine of the SAS.

The test was conducted by ranking the variables (e.g., abundances or biomasses)  $Y_1$  and  $Y_2$  separately and then replacing the original variates with the ranks ( $R_1$  and  $R_2$ ).  $R_1$  was then ordered and paired with  $R_2$ .  $C_i$  was then calculated for each paired ranks ( $R_1$  and  $R_2$ ) by summing the number of ranks greater than  $R_2$ . The value N was then calculated as follows:

$$N = 4 \sum_{i=1}^n C_i - n(n-1)$$

where  $\sum_{i=1}^n C_i$  = the numerator in the calculation of T  
 $\sum C_i$  = the sum of  $C_i$  for all n  
n = the number of paired ranks

The Kendall tau-b correlation coefficient was calculated as follows:

$$r = \frac{N}{[n(n-1) - \sum_{i=1}^m T_1][n(n-1) - \sum_{i=1}^m T_2]}$$

where  $\sum_{i=1}^m T_1(2)$  = a correction term for ties in the ranks of variable  $Y_1$  and  $Y_2$ .

The test of the null hypothesis (that the time value of  $T = 0$ ) was calculated by a normal approximation ( $n > 10$ ) as follows:

$$t_s = \frac{r}{\sqrt{2(2n+5)/9n(n-1)}}$$

$t_s$  is the standard deviation from 0 under the area of the normal curve. The area designated by  $t_s$  is  $1/2 - \sigma$  (Sokal and Rohlf, 1969).

### Chemical data analysis

Due to the relatively limited number of samples collected for chemical analysis compared to the other data sets, and the generally high variability observed within and between the data sets, complex and sophisticated statistical analyses were not warranted. In fact, these analyses may have been misleading, in certain cases, for the chemical data.

The data analysis primarily consisted of subjective contour plotting and simple statistical comparisons, e.g., Students t-test and Wilcoxon rank sum test, as appropriate. Resolution of spatial and temporal differences was limited by the available data to large-scale considerations based on the means of the large groupings. These analyses and their results are discussed in Part V.

## PART V: RESULTS OF THE GEOPHYSICAL STUDIES

### Bathymetry

Several detailed bathymetric surveys of the disposal area were conducted by the Seattle District. The maps presented herein were generated from data collected during the February 1976, December 1978, and August 1979 surveys. Bathymetric data were collected and are presented in feet (U.S. Customary).

Detailed maps of the disposal area are shown in Figures 30 and 31. Before disposal of the dredged material, the most prominent feature in the area was the ridge running approximately north-south through the disposal area. In both postdisposal surveys, the dredged material "mound" was also prominent. The mound was approximately 7 ft (2.1 m) thick and centered on the 186-ft (57 m) contour near the center of the grid. While the mound was the most obvious location of dredged material, some dredged material was spread throughout much of the grid area.

Computer-generated, three-dimensional representations of the disposal area are shown in Figure 32. The mound was apparent in both postdisposal surveys. Another feature of these data was the presence of troughs running east-west through the area. Data were collected along east-west lines. The troughs probably resulted from slight positioning errors or slight errors in the calibration of the signal. Especially in areas where the depth changes rapidly, a slight error in positioning can result in a significant depth change. These east-west features were also present in the bathymetric maps, appearing as horizontal bands.

It was anticipated that, based on these surveys, an estimation of erosion or deposition could be made. The differences in depth between the August 1979 and December 1978 surveys were calculated and a contour plot of the difference was generated (Figure 33). The differences in some areas seemed unreasonably large.

The differences were due to an unexplained 2 ft offset between the surveys. This offset can be seen in Figure 34. The two postdisposal

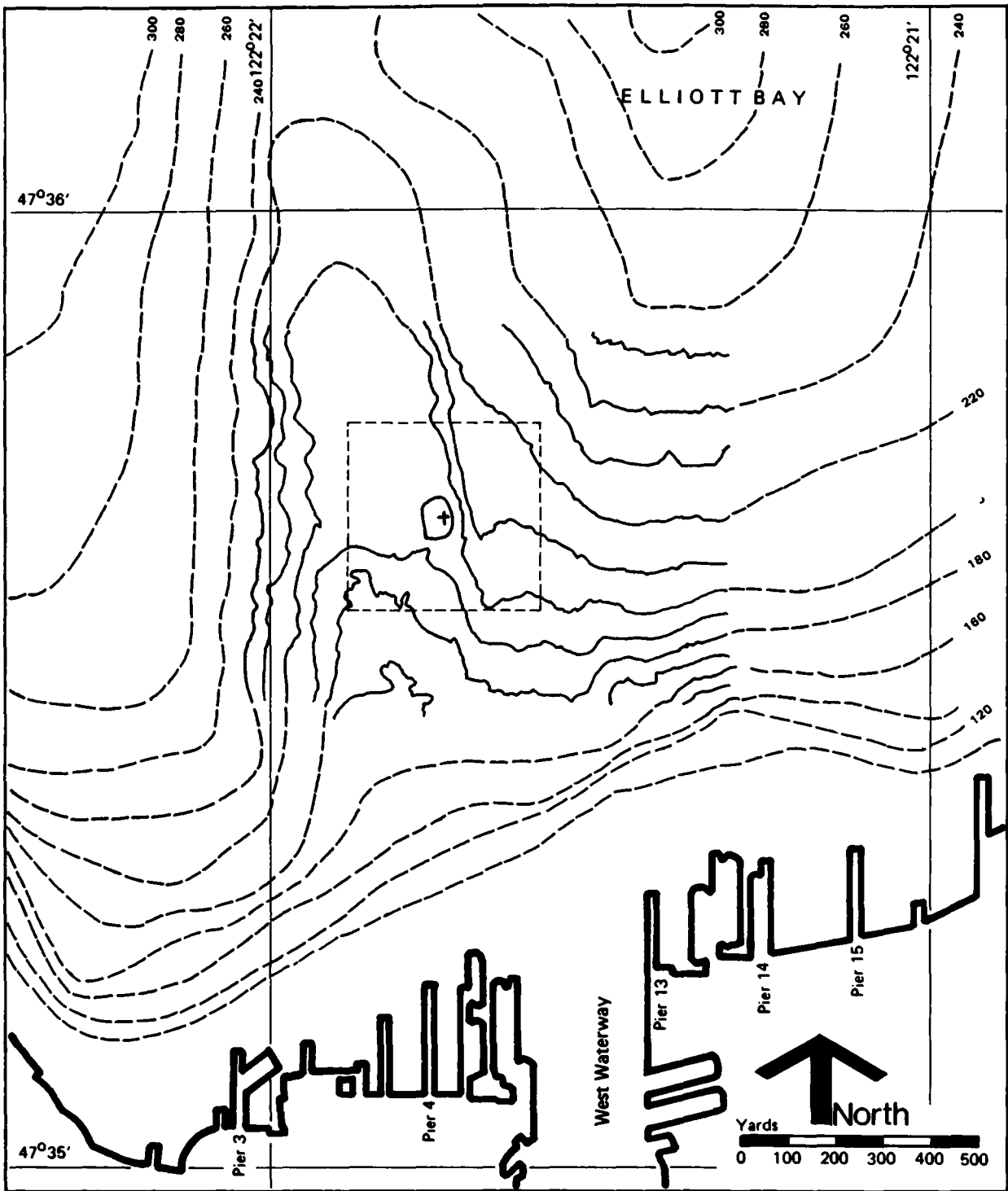

Figure 30. Bathymetric Map of the General Disposal Area. Central section denoted by solid lines was drawn from the detailed survey of December 1970; dashed lines represent extrapolation of data from standard National Ocean Survey nautical chart. Original sampling grid is denoted by dashed square near the middle of the figure

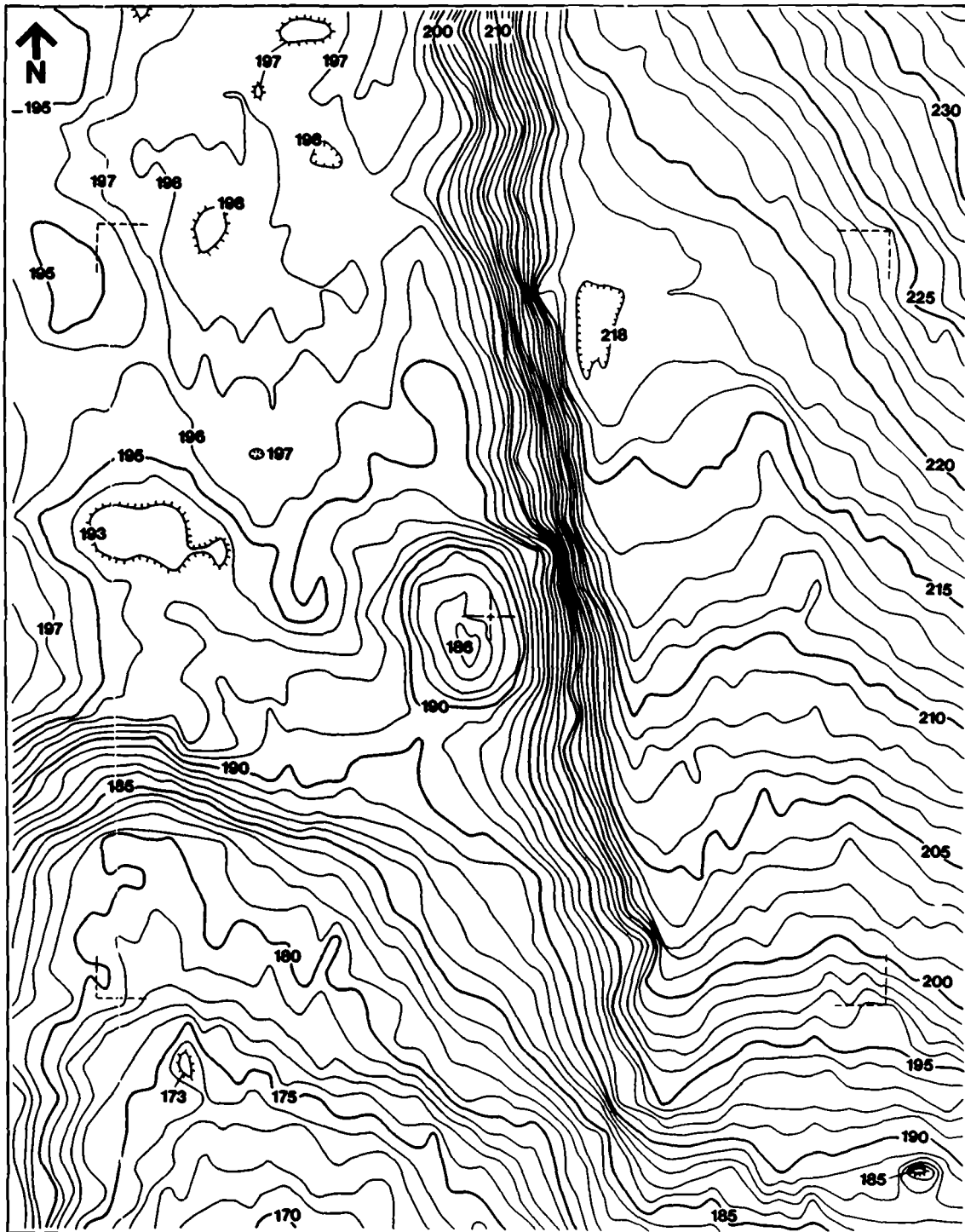

Figure 31. Detailed Bathymetric Map of the Disposal Site, December 1978 Survey. Dashed cross denotes center of original sampling grid, while grid boundaries are noted by dashed corners



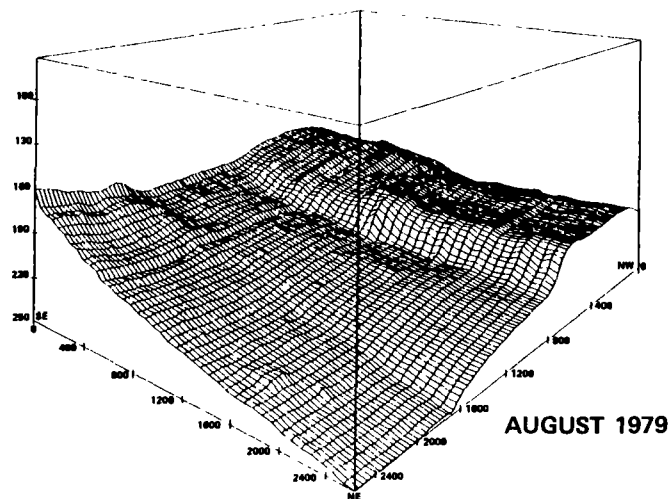
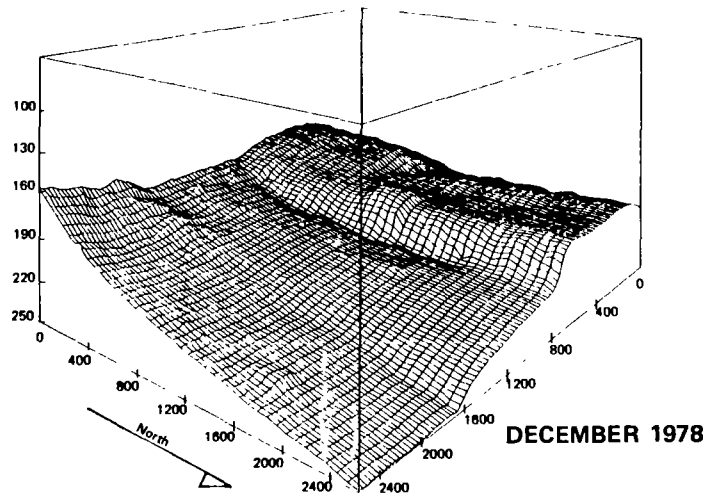
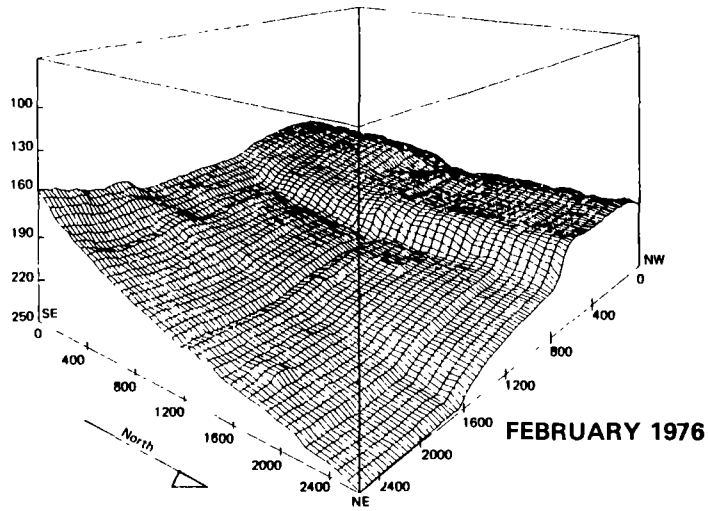

Figure 32. Three-Dimensional Representation of the Bottom Topography of the Study Area: a) February 1976, b) December 1978, c) August 1979.

Area depicted is the same as noted by solid lines in Figure 30

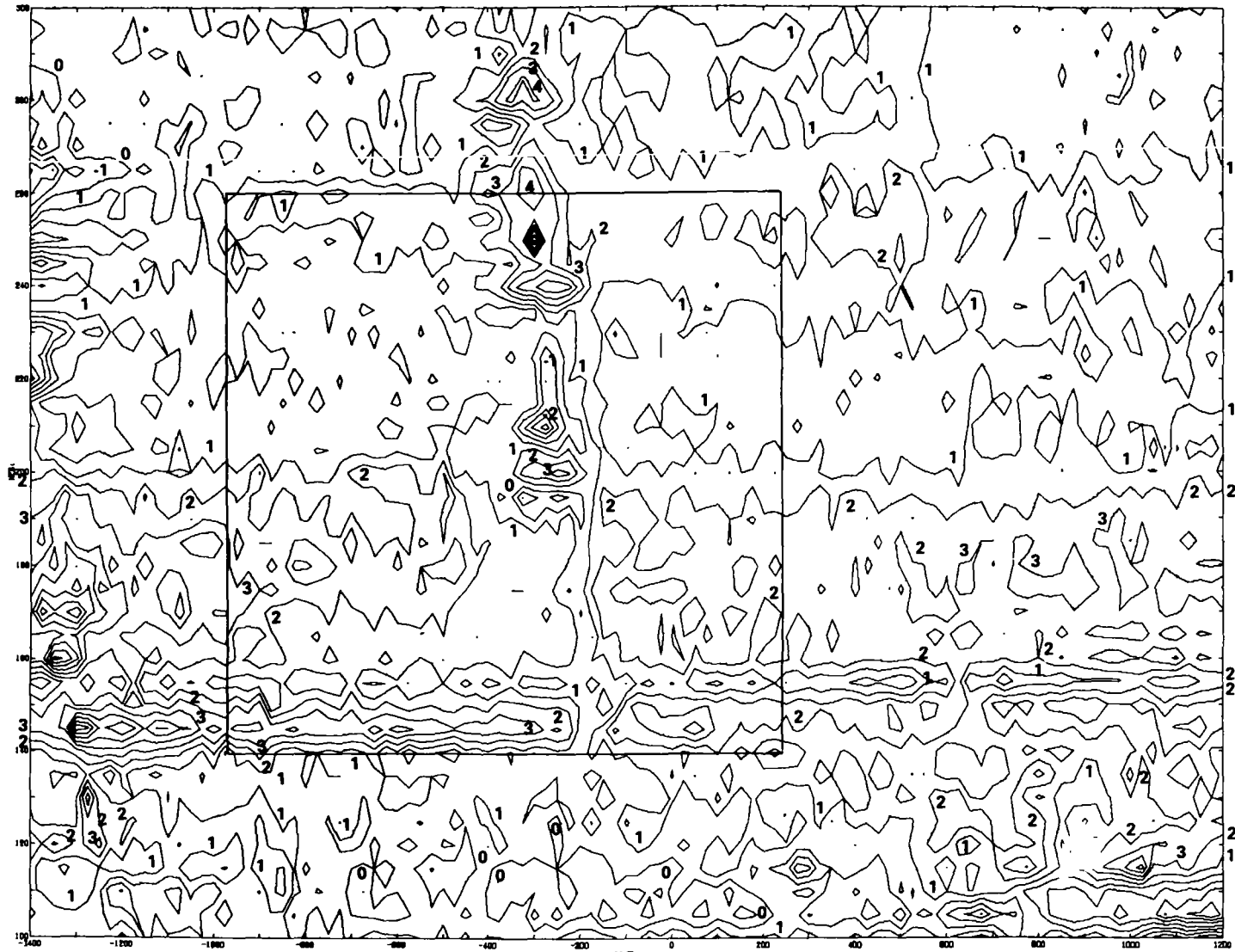

Figure 33. The Difference in Depth (in feet) Between the August 1979 and December 1978 Surveys.  
Original grid denoted by square

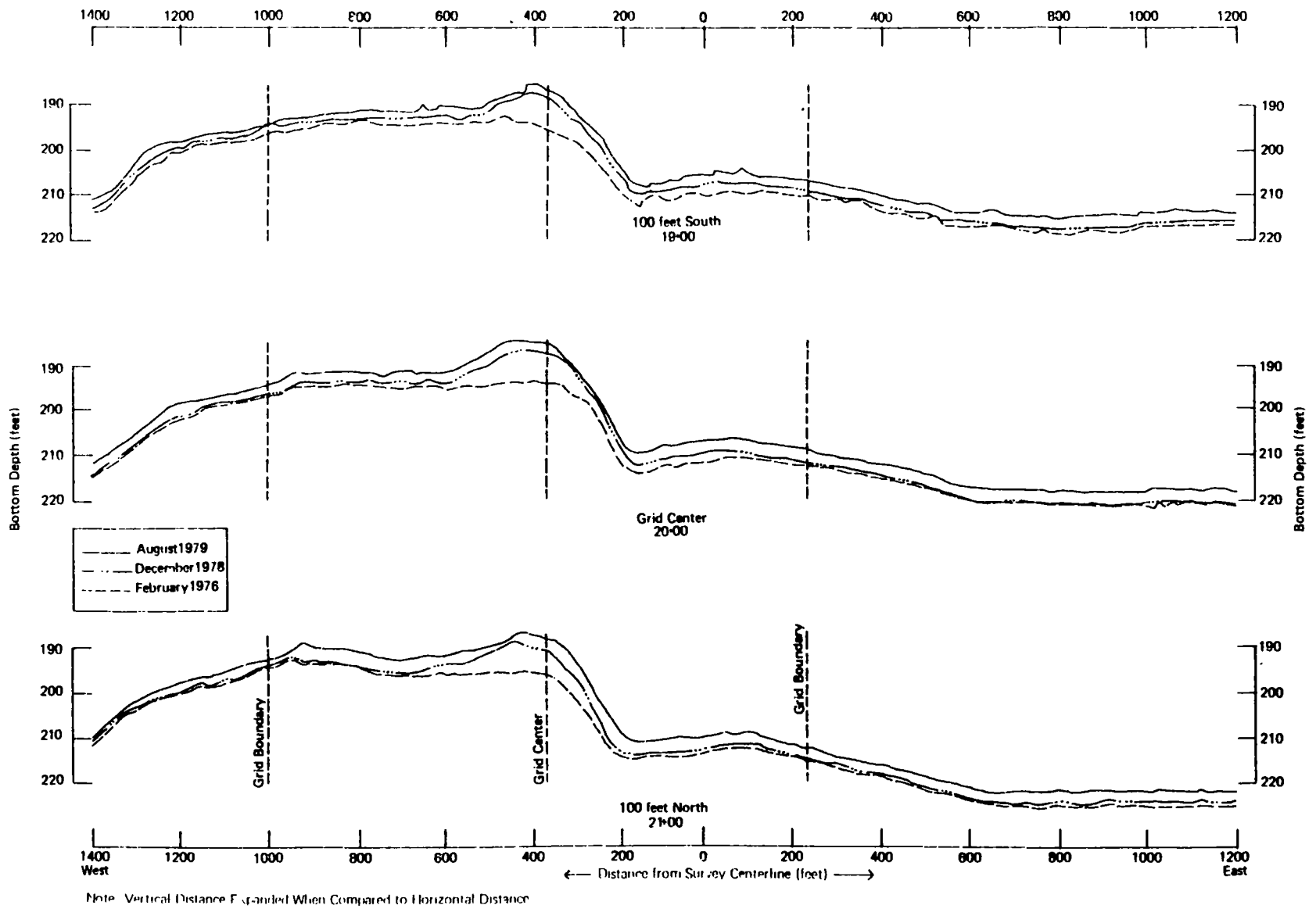

Figure 34. East-West Transects Through the Disposal Site

profiles looked approximately the same but the August 1979 profile shows depths approximately 2 ft shallower. The uncertainty in the measurements should have been on the order of 1 percent of the depth or approximately 2 ft (for 200-foot depth). This amount of uncertainty made volume change calculations meaningless. An error of only 6 in. applied over the entire disposal area corresponded to  $2.7 \times 10^4$  cu yds of material. Due to these uncertainties, volume differences were not calculated.

### Sediment Texture

As previously stated, the raw grain-size data were subjected to basic statistical analyses including calculations of percent gravel, sand, silt, and clay; sand to mud ratio; sorting; skewness; kurtosis; and mean and median phi. The data were then examined to delineate dredged material and establish spatial and temporal trends.

There was very little variability between duplicate analyses of the same sample. Differences in the percents of sand, silt, and clay were usually less than 5 percent. Differences in gravel content were as great as 1.8 percent, due to differences between the sample aliquots. Much of the material in the gravel size class consisted of larger pieces of wood, shells, fruit pits, and seeds, which made it difficult to obtain uniform aliquots. Large differences in percent gravel were the common cause of the larger difference in percent sand, silt, or clay. When the gravel was excluded and percentages recalculated, other large differences disappeared. In comparison to the sample duplicates, there was much greater variability in grain size between sample replicates. Differences of 30 percent in sand content among three replicate surface samples were measured at one or more stations during each cruise. This variability appeared to be characteristic of much of the study area and must be kept in mind when reviewing the general results presented below.

### Spatial trends

In order to obtain an overall view of the sediment distribution in the study area, the mean phi size and percent sand content of the surface sediments were plotted (Figures 35 and 36). In both figures, the station means from cruises 2, 3, and 4 for areas outside the grid

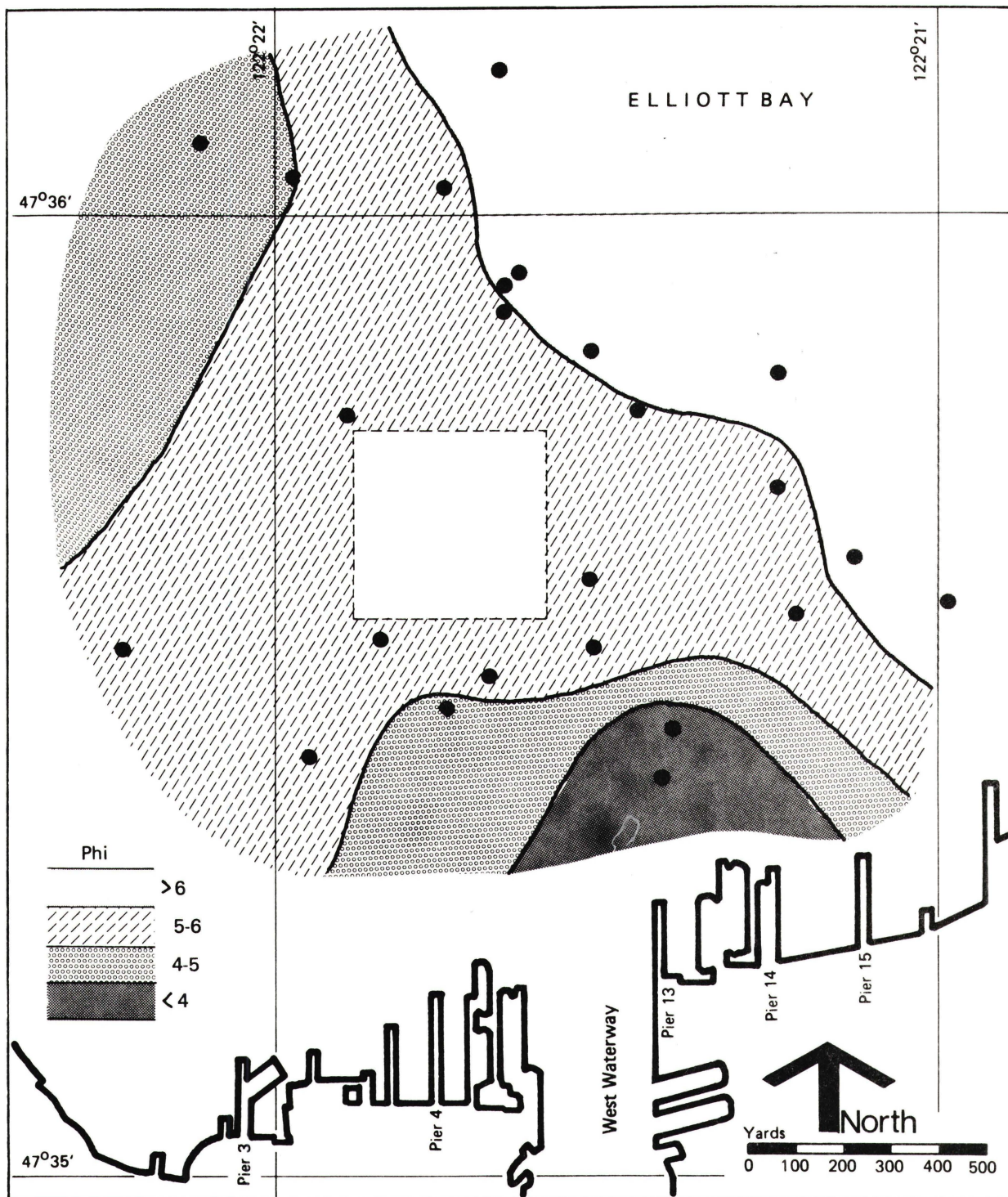

Figure 35. Distribution of Mean Phi for stations Outside the Grid Area. Station means for Cruises 2, 3, and 4 are plotted

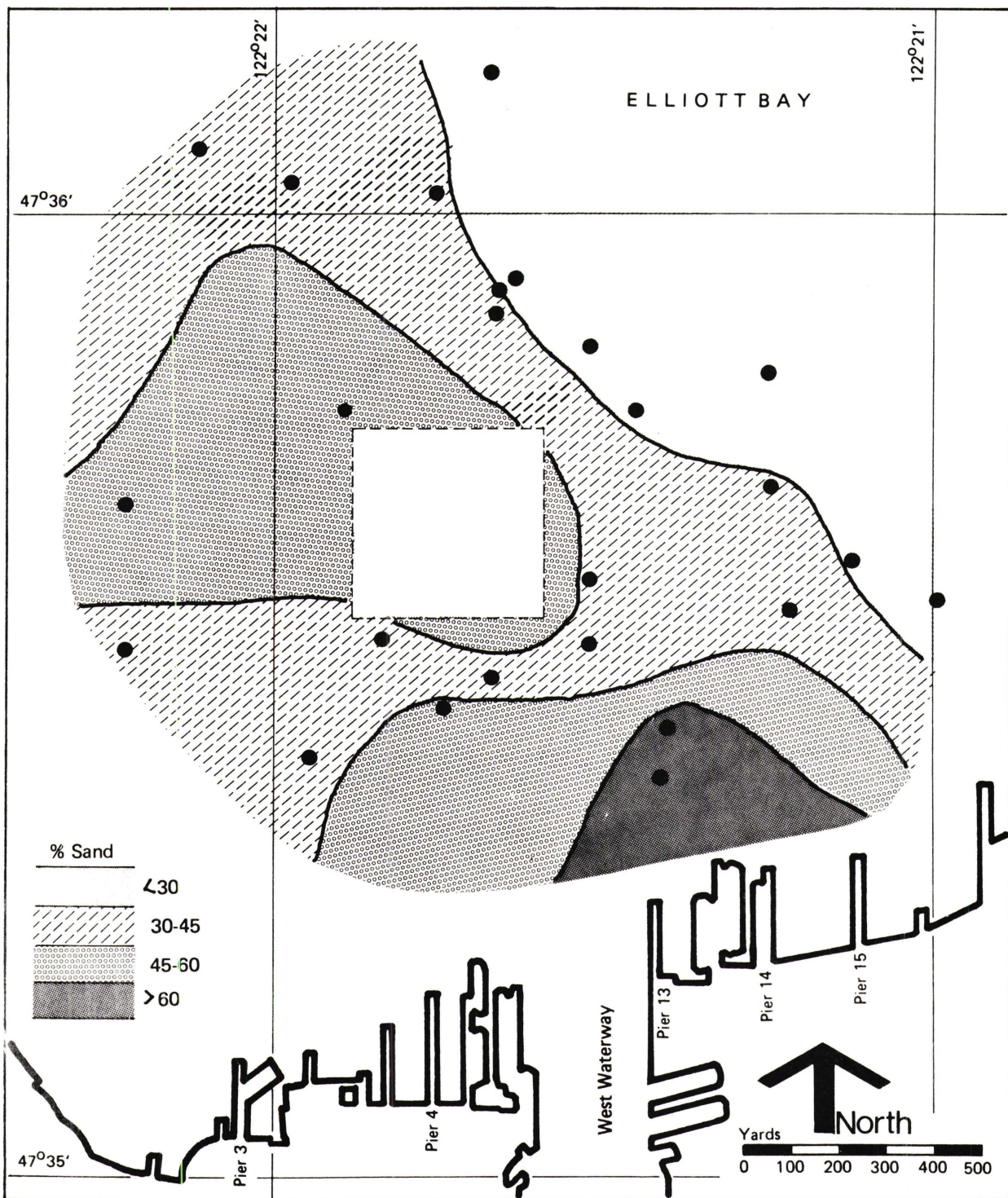

Figure 36. Distribution of Percent Sand for Stations Outside the Grid Area. Station means for Cruises 2, 3, and 4 are plotted

area were plotted. The stations from the three cruises were combined since examining only one cruise at a time would not provide enough points to establish a distribution, and also because stations spaced closely together but sampled on different cruises had similar values of mean phi and percent sand.

The sediment distribution outside the disposal area was controlled by physical processes and, therefore, strong discontinuities should not be present. However, within the disposal area, discontinuities in sediment size were definite possibilities, and contour plotting in the disposal area would be misleading. Therefore, values from this area have been omitted from the two figures.

The mean phi size distribution (Figure 35) showed a general trend toward finer sediments moving north. The contour lines were consistent with the bathymetry contours. Finer sediments were found in deeper water. An exception to this was the trend toward slightly coarser material in the northwestern section of the study area.

The percent sand distribution (Figure 36) showed a somewhat different picture. Although some of the areas corresponded well, other areas did not. All of the samples analyzed had large standard deviations associated with the grain-size distribution, indicating poor sorting. As a result, the distributions of various parameters tend to produce somewhat different spatial patterns, making it difficult to characterize zones of particular sediment types.

Visually, some different sediment types were apparent. In and near the dredged material deposit, as indicated by bathymetry, a layer of black sediment underlain and/or overlain by greenish-gray sediment was observed in many cores. Considering the location of these samples and the known characteristics of the dredged material, this black layer probably consisted of dredged material. In outlying areas, cores were usually fairly uniform with depth and were generally greenish gray in color.

Since the visual characteristics noted in the cores corresponded in distribution with the disposal deposit, but were poorly correlated with the usual sediment textural parameters, patterns in individual phi sizes were examined. The phi size classes were ranked for each sample in

order of abundance. Several patterns in the six most abundant phi sizes were noted, and the majority of the sediments could be classified into six sediment groups based on these recurring patterns. The criteria defining each sediment type are presented in Table 1. The names of the sediment types were chosen to characterize the most abundant phi sizes. The type names do not necessarily relate to the mean phi size or to the percentages of sand, silt, and clay present in any sample.

TABLE 1. CRITERIA USED FOR THE DEFINITION OF SEDIMENT TYPES

Name	Symbol	Criteria - Present in the 6 Most Abundant Sizes
Clay	CL	3 clay fractions
Silt-Clay	SC	4.5 $\phi$ ; 2 silt fractions; and 2 clay fractions
Silt	SI	4.5 $\phi$ , 12 $\phi$ , and 2 silt fractions
Sand-Silt	SS	4.5 $\phi$ , 2.75 $\phi$ , and 3.25 $\phi$
Medium Sand	MS	4.5 $\phi$ , 12 $\phi$ , and 3 fractions from 1.0 to 2.0 $\phi$
Sand	SA	3 fractions from 1.0 to 2.0 $\phi$

By comparing the sediment types with the physical descriptions of the cores, some interesting relationships were established. The percentages of each sediment type (defined in Table 1) comprising each of the visually distinguishable groups were calculated. These are summarized in Table 2. The sand-silt (SS) sediment was primarily associated with black sediments and with the greenish-gray layer overlying much of the black sediment. The silt (SI) type was also associated with the black sediments and to a lesser degree with the overlying greenish-gray sediments. These two sediment types were the only ones commonly comprising material that appeared to be dredged material. Also, they were not commonly found in other areas. It appeared that these two types were indicative of dredged material.



The four other types appeared to be indicative of nondredged material. The medium sand (MS) sediment was associated primarily with the greenish-gray sediments underlying black sediment. To a much lesser degree, the MS type was associated with the subsurface portion of uniformly greenish-gray cores. The silt-clay (SC) type was associated with uniformly greenish-gray sediments, both surface and subsurface portions.

The clay (CL) sediment type was associated with surface samples from greenish-gray cores. This type also comprised minor amounts of all other groups except black sediments. The sand (SA) type was not very common and did not account for more than 20 percent of any group. Its primary association was with the greenish-gray sediments, which were overlain by black sediments.

TABLE 2. APPROXIMATE PERCENTAGES OF SEDIMENT TYPES COMPRISING VISUALLY DISTINGUISHABLE GROUPS

Physical Description	60-50%	30-20%	19-10%	9-5%	<4%	Not Occurring
Black (47%)+	SS	SI		*	MS,SC,SA	CL
Greenish-Gray overlying Black (11%)	SS		SI,SC	CL,*	MS,SA	
Greenish-Gray underlying Black (15%)	MS		SA	*,SS,SI,CL	SC	
Uniform Greenish-Gray 0-5 cm (8%)	SC	CL	*	SI	MS,SS	SA
Uniform Greenish-Gray below 5 cm (11%)	SC		MS,*,SI		SA,CL	SS
Other colors, mixtures, striations, etc. (8%)		MS,SI,*,SC			SS,CL	SA

\* Sediment samples which do not fit into any sediment type defined in Table 1.

+ Percentages refer to the percent of all samples analyzed which fit into each group.

### Delineating the dredge disposal

Assuming that the black sediment was dredged material, the greenish-gray sediment underneath the deposit was the surface sediment previous to disposal. This greenish-gray sediment was primarily type MS. A plot of the depth of the MS subsurface horizon is indicative of the sediments deposited since that time. This would include the dredged material deposit and natural deposition (Figure 37). Using the MS subsurface horizon, the mean phi of the old surface layer was plotted (Figure 38). Comparing Figures 35 and 38, it appeared that the more recent surface sediments (1979-80) were finer than the older (pre-1976) sediments.

### Temporal trends

To identify any temporal trends in the study area, changes in the mean phi size of surface sediments at several locations in the grid area were examined. As previously mentioned, all cores collected in the original grid area were plotted (Figure 39) and five groups were defined. In defining the groups, an effort was made to include three cores from each cruise spaced fairly close together. The groups are shown in Figure 39.

Linear regressions of cruise means of percent sand and mean phi versus time were calculated. These results are presented in Table 3 and Figure 40. The figure is a plot of the cruise means versus time, the calculated regression line, and ranges corresponding to one standard deviation above and below the cruise means. The correlation coefficients of the linear regression lines showed a tendency through time toward decreasing percent sand and increasing mean phi, i.e., finer sediments.

TABLE 3. CORRELATION COEFFICIENTS OF LINEAR REGRESSIONS OF CRUISE MEANS VERSUS TIME

Group	% Sand (Figure 40a)	Mean Phi (Figure 40b)
1	-0.76	0.64
2	-0.91	0.81
3	-0.76	0.58
4	-0.09	0.15
5	-0.19	-0.19

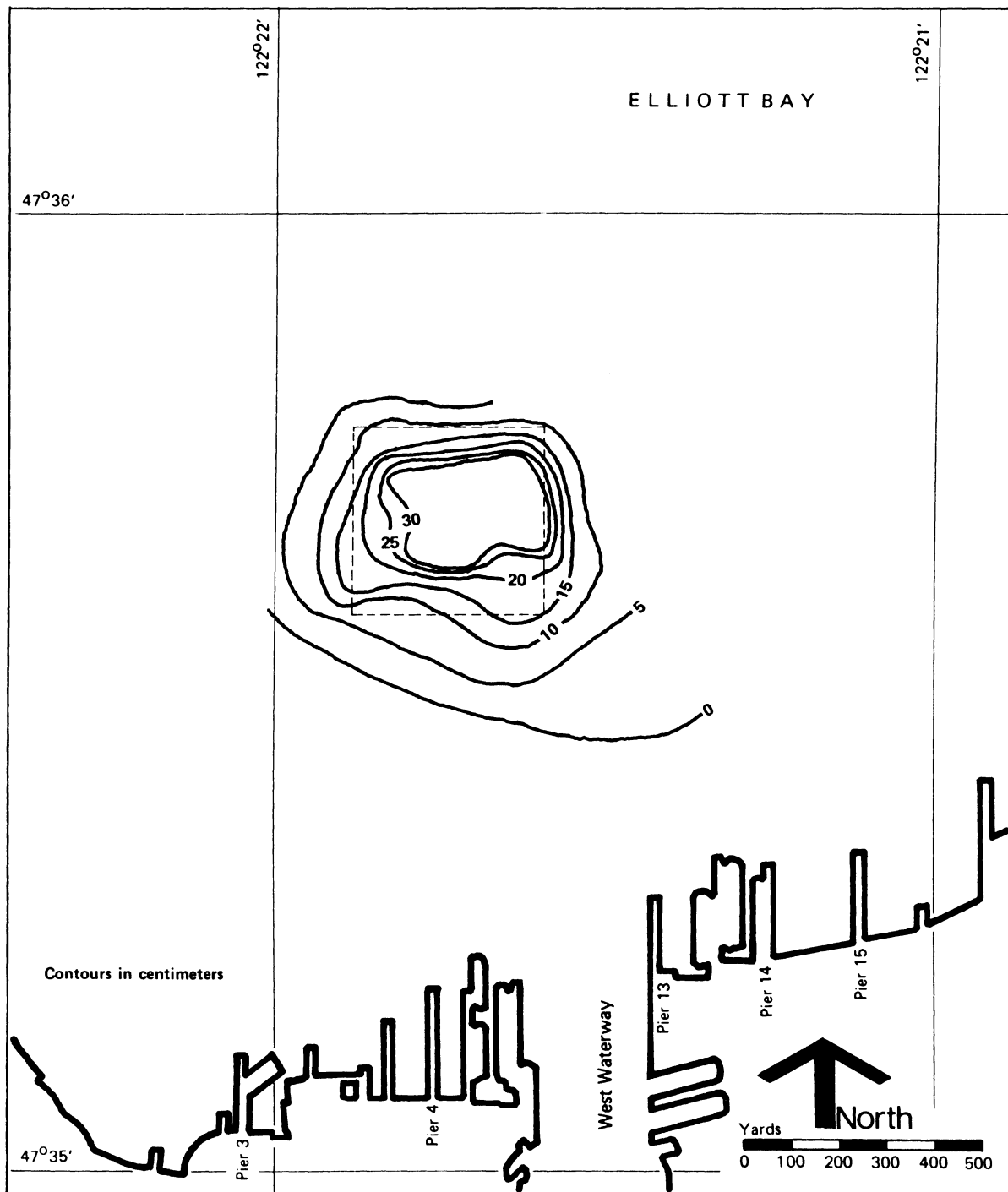

Figure 37. Contour Plot of the Depth of the MS Subsurface Horizon

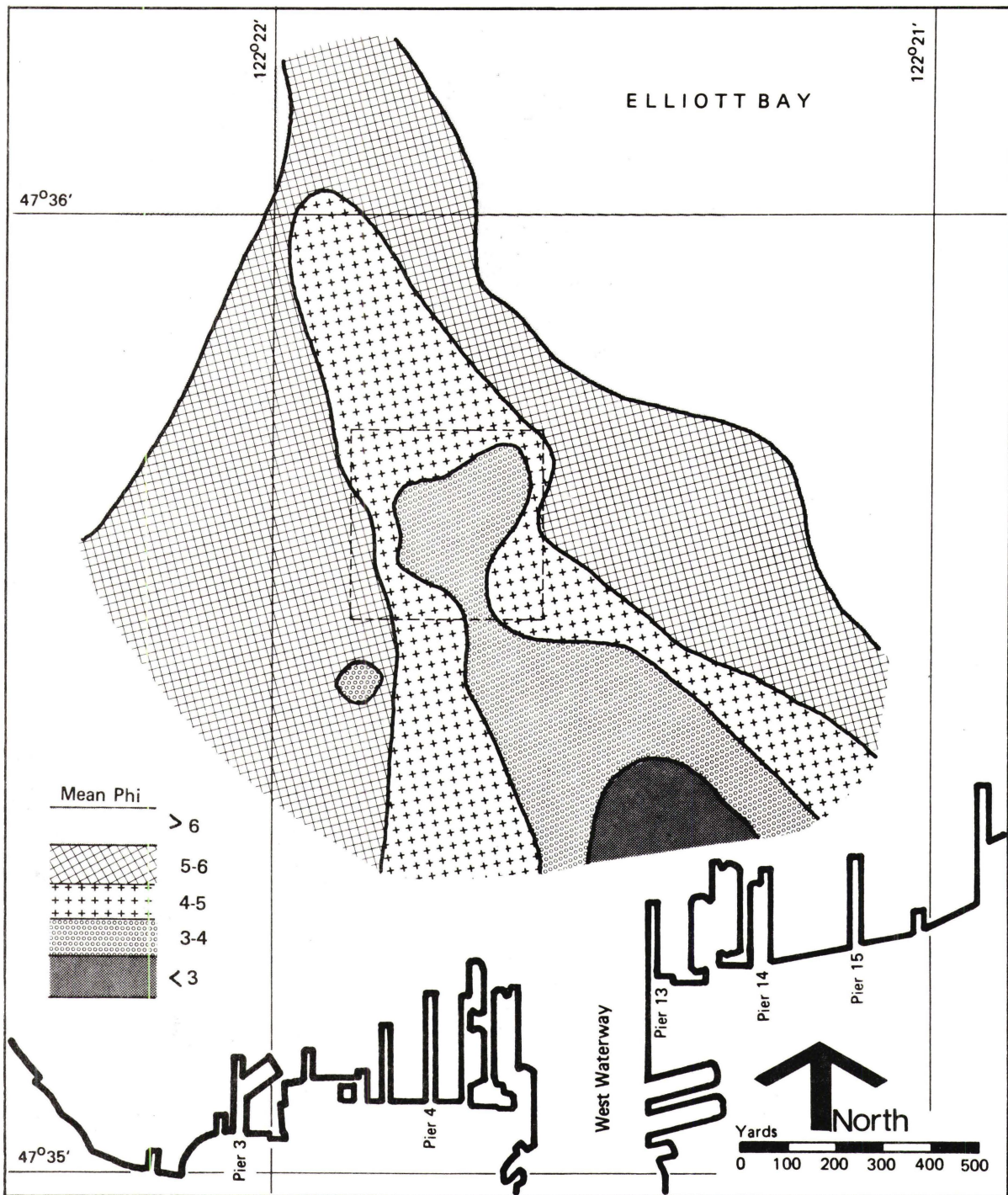
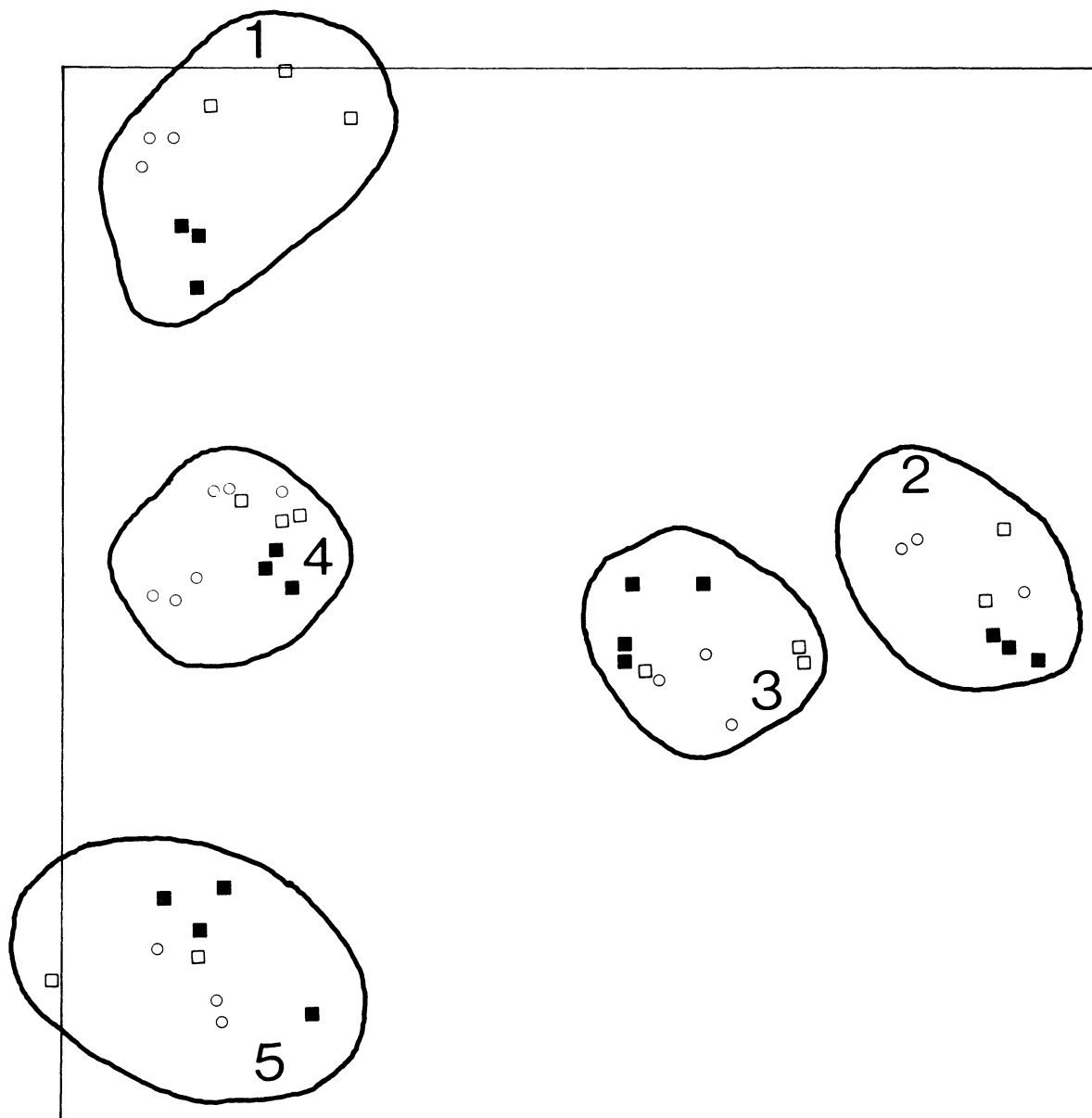

Figure 38. Distribution of the Mean Phi of the Predisposal Surface Layer. Based on the MS Subsurface Horizon



- May 1979 Cruise
- October 1979 Cruise
- May 1980 Cruise

Figure 39. Groupings Used for Temporal Trend Analysis.  
 Square corresponds to the original grid area

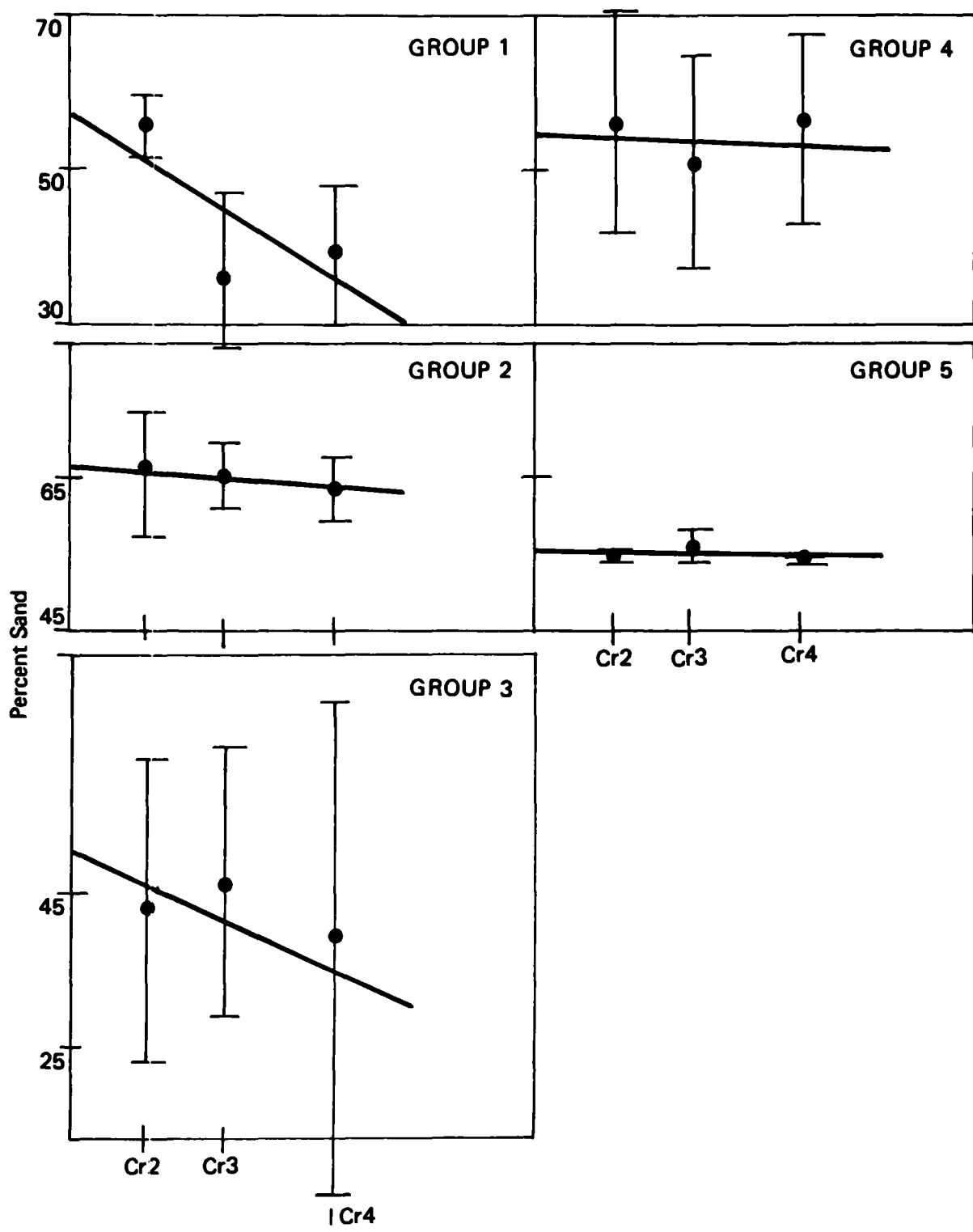

Figure 40a. Linear Regression of Cruise Means of Percent Sand versus Time. Dots are cruise means; ranges are one standard deviation above and below the mean

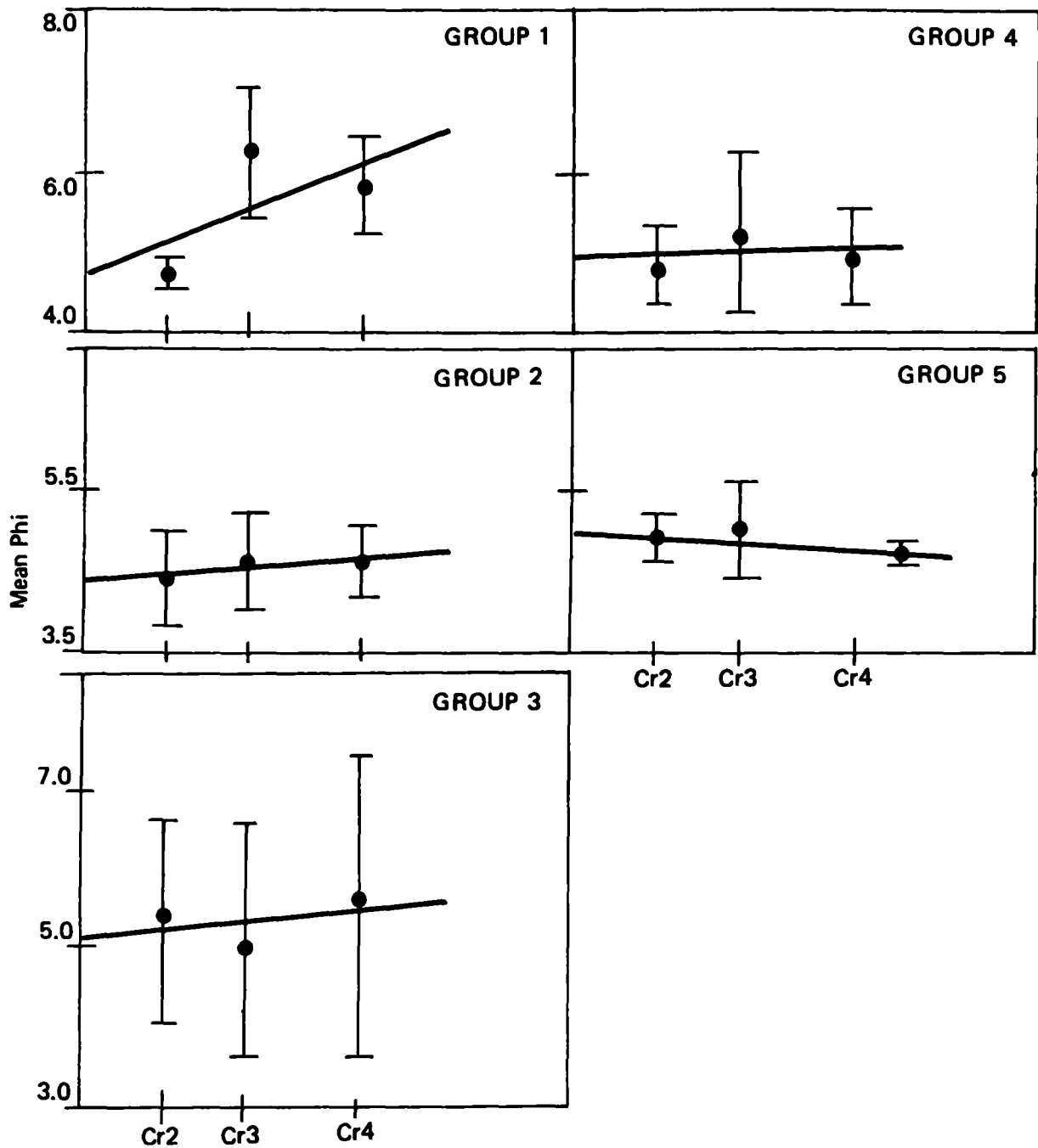

Figure 40b. Linear Regression of Cruise Means of Mean Phi versus Time. Dots are cruise means; ranges are one standard deviation above and below the mean

However, since cruise means ignore variability within cruises, a comparison was also made of the spatial variability within cruises to the temporal variability between cruises. The standard deviation was used as a measure of variability. For each group, the average and standard deviation of the cruise means were calculated. The standard deviation of the average is a measure of the variability of a parameter between cruises (through time). This was compared to the average of the standard deviations for each cruise. These calculations are presented in Table 4.

TABLE 4. COMPARISON OF VARIABILITY WITHIN CRUISES TO VARIABILITY BETWEEN CRUISES

	<u>% Sand</u>		<u>Mean Phi</u>	
	<u><math>\bar{x}</math></u>	<u>s</u>	<u><math>\bar{x}</math></u>	<u>s</u>
Group 1				
Cruise 2	55.3	4.0	4.7	.21
Cruise 3	37.1	10.4	6.2	.78
Cruise 4	38.8	9.0	5.8	.61
Average	43.7	<u>7.8</u>	5.6	<u>.53</u>
Standard Deviation	<u>10.1</u>		<u>0.78</u>	
Group 2				
Cruise 2	65.3	7.8	4.4	.57
Cruise 3	65.3	4.3	4.6	.57
Cruise 4	63.3	4.3	4.6	.44
Average	64.6	<u>5.5</u>	4.5	<u>.53</u>
Standard Deviation	<u>1.2</u>		<u>.12</u>	
Group 3				
Cruise 2	43.1	20.0	5.3	1.31
Cruise 3	47.2	18.1	5.1	1.48
Cruise 4	38.1	32.7	5.5	1.90
Average	42.8	<u>23.6</u>	5.3	<u>1.56</u>
Standard Deviation	<u>4.6</u>		<u>0.20</u>	
Group 4				
Cruise 2	56.4	14.4	4.8	.47
Cruise 3	50.9	13.7	5.2	.95
Cruise 4	55.3	12.2	4.9	.64
Average	54.2	<u>13.4</u>	5.0	<u>.69</u>
Standard Deviation	<u>2.9</u>		<u>.21</u>	
Group 5				
Cruise 2	54.5	0.4	4.9	.28
Cruise 3	56.2	2.0	5.0	.59
Cruise 4	54.3	0.04	4.7	.14
Average	55.0	<u>0.8</u>	4.9	<u>.34</u>
Standard Deviation	<u>1.0</u>		<u>.15</u>	



In almost all cases, the variability of the grain-size parameters within a cruise was greater than the variability between cruises. For example, in group four, the cruise means of percent sand were 56.4, 50.9, and 55.3. So, for the entire group, the average was 54.2 with a standard deviation of 2.9. This standard deviation value represents the temporal variability of the cruise means of percent sand. In comparison, the standard deviations of the cruise means were 14.4, 13.7, and 12.2 with an average of 13.4. These latter values represent the spatial variability of the cruise means.

Thus, the spatial variability within each cruise was greater than the temporal variability between cruises. Even if a temporal trend did exist, it could not be established due to the uncertainty generated by the spatial variability.

### Current Measurements

#### Mean flow

The 1980 current meter deployment produced a more complete record of currents than did the first deployment. Therefore, the mean flow characteristics are based on data measured during the 1980 deployment. Mean (net) current velocities were determined for the meters at 15, 22, 37, and 42 m above the bottom. Since direction was not recorded at the Aanderaa meter fixed to the tripod (3 m above bottom), the net current could not be calculated. Mean current speeds for all five depths were also calculated. Net currents were toward the south and southeast. These values are presented in Table 5 and Figure 41.

TABLE 5. SUMMARY OF MEAN CURRENT VALUES

<u>Height above Bottom, m</u>	<u>Net Currents</u>		<u>Absolute Speed Mean, cm/sec</u>
	<u>Speed cm/sec</u>	<u>Direction ° True</u>	
42	2.49	180	3.83
37	1.93	143	3.58
22	1.03	154	2.76
15	.64	111	4.30
3	----	---	5.96

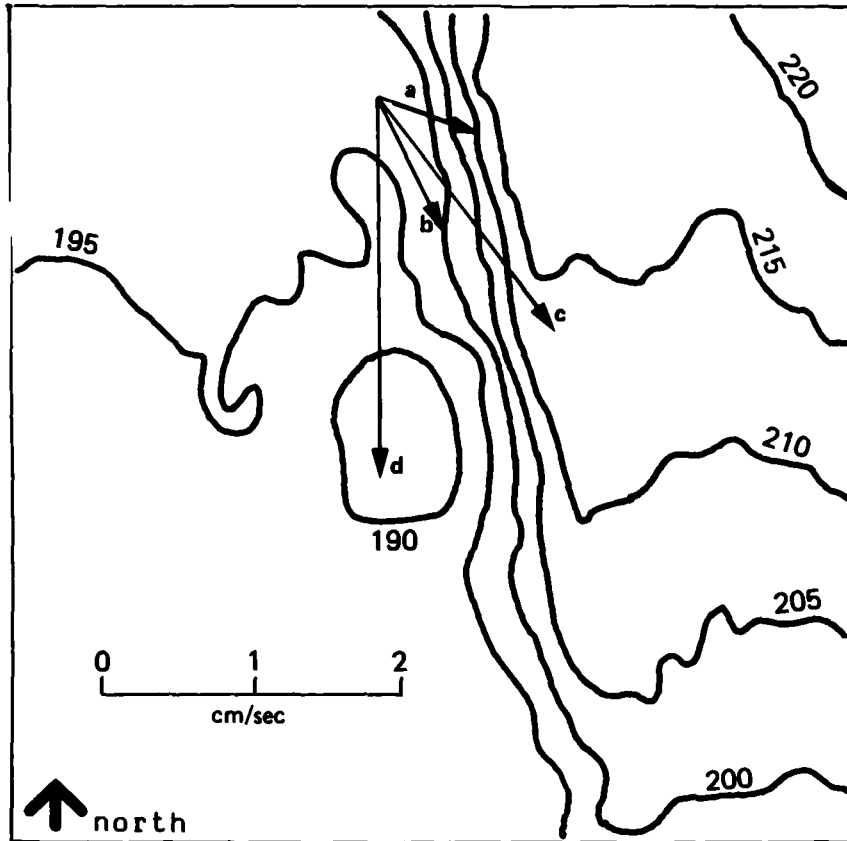

Figure 41. Mean Current Vectors and Bathymetry (ft) at Mooring Site During August - September 1980. Distances above bottom are: a) 15 m, b) 22 m, c) 37 m, and d) 42 m

### Extreme values

Extreme values of currents must be known to determine the extent of sediment transport. Based on measured values of daily maximum currents, and using the method explained in the data analysis section, one year extreme currents were predicted. The daily maximum currents plotted versus probability and the points corresponding to the 1-yr maximums are shown in Figure 42.

For the bottom current meters, the extreme values computed from the 1979 and 1980 data were 26 and 23 cm/sec, respectively. The lower extreme value in 1980 was probably due to differences in the tidal ranges and sampling interval. During the 1979 deployment, there were more occurrences of tidal ranges in excess of 4 m. This could have produced stronger currents. Also in 1980, the sampling interval was increased from 15 to 30 min, which could have produced a lower current averaged over the sampling interval.

### Sediment transport

Sediment transport is initiated when the boundary shear stress exceeds the critical boundary shear stress of the bed. The critical boundary shear stress  $T_c$  is dependent on grain size ( $D$ ), water viscosity ( $\nu$ ), water density ( $\rho$ ), and sediment density ( $\rho_s$ ), and was determined for a number of phi sizes. A critical shear velocity ( $u_{*c}$ ) was calculated for each  $T_c$  from the relation.

$$T_c = \rho u_{*c}^2$$

A range of critical Reynolds numbers ( $R_{*c}$ ) was then calculated from  $R_{*c} = \frac{u_{*c} D}{\nu}$

Using Nikuradze's diagram,  $z_0$  was determined for each  $R_{*c}$ .

The Karman-Pradle equation,

$$u(z) = \frac{u_*}{K} \ln z/z_0$$

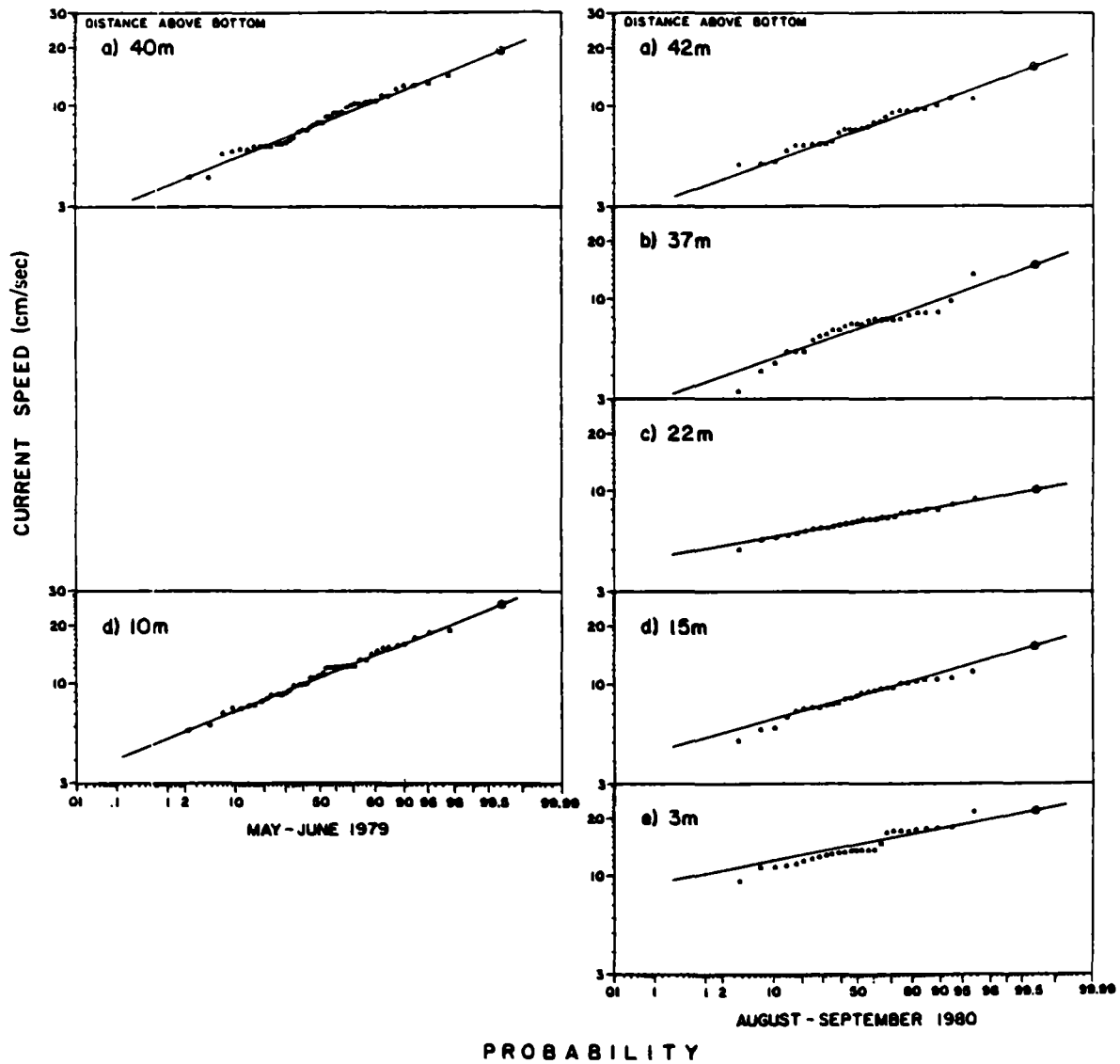

Figure 42. Daily Maximum Current Speed versus Probability. Small dots are daily maximum current speeds. Large dots are one year extreme current speed estimation

relates the velocity  $u$  at depth  $z$  above the bottom to the shear velocity  $u_*$ , von Karman's constant  $k$ , and the natural log of  $z/z_0$ . The depths chosen were 2 m (200 cm) or 3 m (300 cm) since these were the depths of the deepest current meter which could be used for comparison. Knowing the critical values of  $u_*$  and  $z_0$  a critical value for the velocity at 2 m,  $u_c(200)$  and at 3 m,  $u_c(300)$  can be calculated from:

$$u_c(200) = \frac{u_*^c}{k} \ln \frac{200}{z_0}$$

$$u_c(300) = \frac{u_*^c}{k} \ln \frac{300}{z_0}$$

If the actual observed value of  $u$  exceeded the calculated critical value  $u_c$ , the sediment could move.

The results of these calculations are summarized in Table 6. It should be noted that all of these calculations are for noncohesive sediments, but the sediments in the study area are cohesive. Therefore, the values shown for the critical velocities ( $u_c$ ) required to move sediments are actually minimum velocities. Higher velocities would be required to move the cohesive sediments in the study area.

TABLE 6

TABLE 6. SEDIMENT TRANSPORT CALCULATIONS

$\emptyset$	D(cm)	$u_*^c$ (cm/sec)	$z_0$ (cm)	$u_c(200)$ cm/sec	$u_c(300)$ cm/sec
2	$2.5 \times 10^{-2}$	1.43	$1.0 \times 10^{-3}$	43.6	45.1
3	$1.25 \times 10^{-2}$	1.33	$1.1 \times 10^{-3}$	40.3	41.6
4	$6.25 \times 10^{-3}$	0.96	$1.5 \times 10^{-3}$	28.3	29.3
5	$3.12 \times 10^{-3}$	0.81	$1.8 \times 10^{-3}$	23.5	24.3
6	$1.56 \times 10^{-3}$	0.71	$2.0 \times 10^{-3}$	20.4	21.2
7	$7.81 \times 10^{-4}$	0.62	$2.3 \times 10^{-3}$	17.6	18.3

OBSERVED VALUES

currents exceeded 15 cm/sec: 0.68% of combined deployment periods  
currents exceeded 20 cm/sec: 0.16% of combined deployment periods  
maximum value 23.3 cm/sec: one 15 minute reading

During the 1979 deployment, current speeds actually observed at 2 m above the bottom exceeded 15 cm/sec for 0.5 percent of the time during the deployment period. Currents exceeded 20 cm/sec for a total of 0.25 percent of the time. The maximum velocity (one 15-min reading) during the 40 day deployment was 23.3 cm/sec. Velocities were predominantly 10 to 12 cm/sec and appeared to change directions in response to the tides.

During the 1980 deployment, current speeds at 3 m exceeded 15 cm/sec 1.0 percent of the time. Currents exceeded 20 cm/sec for 0.1 percent of the deployment period. The maximum observed current was 21.5 cm/sec.

Based on the calculated extreme current values, sediments of 5 phi or finer could be resuspended approximately 1 day per year.

### Summary and Conclusions

The bathymetry surveys indicated that dredged material was deposited throughout the original grid area with a prominent mound near the center of the grid. In 60 m of water, the survey equipment was not precise enough to obtain data suitable for volume change calculations.

From the sediment grain-size analyses, six sediment types were defined (Table 1). By comparing these types with the physical characteristics of the sediment, it was apparent that two types (SS and SI) were indicative of dredged material. Comparing these types with PCB concentrations (discussed in Part VII) also showed that the SS and SI types were primarily dredged material.

The greenish-gray layer which overlaid much of the black sediments could have been biologically reworked dredged material, new natural deposition, or a combination of both. In areas away from the dredged material, the surface layer was dominated by generally finer sediments, the SC and CL types (Table 2). This surface layer was representative of the natural deposition in the bay. If the surface greenish-gray layer at the disposal site were new material, it should have been similar in composition to the surface layer in surrounding areas. However, the surface layer at this disposal site was more similar to the black sediment group, with over 50 percent of both groups being the SS sediment

type. Although a major similarity exists, there are also some differences. None of the black sediments analyzed were type CL and less than 4 percent were type SC. The surface greenish-gray layer had higher frequencies of both these types (Table 2). Based on these distributions, it appeared that the surface greenish-gray layer overlying black sediments was a combination of biologically reworked dredged material and newly deposited material.

A comparison of the predisposal surface layer (Figure 38) and the recent surface layer (Figure 35) indicated that the recent surface sediments were finer than the older sediments. However, this trend could not be verified by temporal changes occurring during the timespan of the project (February 1979 through May 1980). Very large temporal changes would have had to occur to be distinguishable from the large spatial variability.

The mean flow of the bottom water near the disposal area was toward the south or southeast. If sediments were being transported by the currents, they should have moved in this direction. Comparing the extreme values of the current to the critical value, it appeared that some silt and clay material may have been resuspended a small percentage of the time. However, the effect of sediment cohesion probably prevented any significant sediment movement.

This conclusion was supported by the transmissometer readings and bottom photographs. The transmissometer showed low concentrations of suspended sediments during both deployments. More importantly, there were no significant fluctuations in concentration, which would be indicative of resuspension episodes. The bottom photographs were very clear. In most cases, bottom features such as worm holes were distinct and recognizable through many photographs.

## PART VI: RESULTS OF THE BIOLOGICAL STUDIES

### Biological Quality Assurance

#### Sampling and sorting

Identification of macrofauna from the reconnaissance cruise revealed certain stations with unusually low abundances. In particular, all replicates from stations 101, 106, and 107 contained no or very few polychaetes and live molluscs. A possible sample preservation problem was evident from bench sheet notations that stated that 21 percent of the samples had no visible macrofauna or had partially decayed organisms.

The entire February biological data set was, therefore, examined to determine which samples should be deleted from further analysis. The data set examination was subjective in that no statistically based procedure exists for unbiased editing of replicates with preservation problems. All analyses of the February biological data should, therefore, be considered with some care and conclusions regarded as tentative.

The February data examination considered six taxa: 1) Axinopsida serricata, 2) Glycera capitata, 3) Capitellidae, 4) Euclymeninae, 5) Paraonella spinifera, and 6) Laonice cirrata. Samples were deleted if they contained no or much fewer organisms compared to the replicates from the same station. The result of these comparisons was to delete from further analysis 15 of the 90 samples: Station 101, Replicates 1,2,3; Station 106, Replicates 1,2,3; Station 107, Replicates 1,2,3; Station 102, Replicate 1; Station 104, Replicate 1; Station 105, Replicate 2; Station 117, Replicate 1; Station 121, Replicate 1; and Station 126, Replicate 1.

Identification of macrofauna from the study cruises did not reveal similar sample problems, because each sample bottle was filled only two-thirds full with sample and preservative was added immediately. Also, the sample bottles were rechecked immediately upon arrival at the lab.

Review of the bench notes for the May 1979 cruise identifications did reveal partial dissolution of the shells of some of the smaller molluscs (Axinopsida serricata and Macoma carlottensis). This condition



was not similar to the previous decay condition in that tissue from the delicate, soft-bodied macrofauna was still intact. Although this condition had no effect on the abundance data, it is uncertain what effect it may have had on the biomass analyses. This condition was, fortunately, documented for very few replicates:

#### May 1979 Cruise Bench Sheet Notations

Station 103, Replicate 1...partial dissolving in 2 of 3 sample bottles  
Station 106, Replicate 1...partial dissolving in 1 of 3 sample bottles  
Station 111, Replicate 1...partial dissolving in 1 of 3 sample bottles  
Station 132, Replicate 1...slight, partial dissolving in 1 sample bottle  
Station 140, Replicate 1...partial dissolving in 1 sample bottle  
Station 109, Replicate 2...partial dissolving in 1 sample bottle  
Station 131, Replicate 2...slight dissolving in 1 sample bottle  
Station 109, Replicate 3...much dissolved with soft shells in 1 sample bottle

Review of bench notes for October 1979 and May 1980 cruises did not reveal similar conditions. However, two samples (station replicates) from the October 1979 cruise were deleted from further analyses because bench notes revealed that at least one of the vials containing sorted organisms was misplaced in the lab; therefore, the data were not recorded. This reduced the number of samples for October 1979 from 60 to 58.

#### Taxonomic identifications

Disagreements in taxonomic identification which occurred during the quality assurance checks were resolved through written and verbal communications.

The results of the independent verification of the reference collection revealed taxonomic disagreements for species of Euclymeninae and Capitellidae. As a result, all Euclymeninae and all Capitellidae were combined and analyzed to subfamily and family, respectively, for the three remaining cruises. Disagreement also occurred regarding the naming of four of the less common polychaete taxa; however, this did not adversely affect the subsequent data analyses on predominant taxa.

The results of the verification of the reconnaissance cruise sample (CR 1, STA 112, REP 1) revealed that two polychaete taxa had been misidentified (both not abundant). An unresolved disagreement also occurred in the identification of two bivalve taxa, neither of which were abundant. A further concern arose from discrepancies in the recounts of the small bivalve, Axinopsida serricata. The counting technique required that the shells be crushed to determine if they were live or dead. Subsequent count verification, therefore, became difficult, if not impossible. The verification of the counts for one sample (station replicate) revealed a mean count of 118 with a coefficient of variation (C.V.) of 25 percent. However, this may be compared to the C.V. for the variability between samples (station replicates) of this species. The C.V. for both May cruises was 69 percent (n = 119) and in the October cruise was 79 percent (n = 58), both considerably higher than the apparent single sample variability.

The results of the blind reanalysis of the six October samples revealed an improved C.V. on Axinopsida serricata counts. Five of six samples had a C.V. less than 7 percent; one had a C.V. of 24 percent. The C.V. for Capitellidae ranged from 4 to 11 percent and from 6 to 13 percent for Euclymeninae. This compared to the C.V. between samples for Capitellidae and Euclymeninae of 68 and 58 percent, respectively.

Finally, data for Macoma carlottensis adults and juveniles and for Psephidia lordi were combined into one group due to the difficulty of distinguishing between these species.

Overall, the results of the biological quality assurance (QA) program showed that concerns did arise during the project. Most of these centered around less abundant taxa and were not major problems. One definite effect of the QA program was to increase the awareness of potential problems to all scientists and technicians involved, which hopefully minimized errors. It was not possible to compare the accuracy of the project work to others in the region simply because few scientists report the results of QA programs in any detail. This statement is based on a review of benthic faunal studies for Puget Sound (Dexter et al., 1981).

## Biological Characterization

Analyses of macrofauna abundances and biomasses have been conducted on data from the four cruises. Discussions are based on mapping, cluster analysis, spatial autocorrelation, Wilcoxon's two-sample test, and Kendall tau-b correlation analysis. The February 1979 cruise data, although discussed with respect to mapping and cluster analyses, are given less emphasis due to the uncertainty in the data.

### Summary of past biological observations

The rationale for conducting a biological study was to determine whether or not the benthic macrofauna at the disposal site responded to the effects of dredged material on a long-term basis. The previous biological investigations (reported in Tatem and Johnson, 1978; Harman and Serwold, 1978; and Bingham, 1978) documented the short-term effects of disposal on benthic macrofauna.

The benthic macrofauna of southern Elliott Bay, as documented by Harman and Serwold (1978), were dominated by the pelecypods Macoma carlottensis, Axinopsida serricata, Yoldia sp., and Nucula tenuis. Dominant gastropods included Mitrella gouldi and Odostomia sp., while dominant polychaetes included Euclymene zonalis (included as Euclymeninae in the current data), Heteromastus filobranchus (included as Capitellidae in the current data), Lumbrineris luti, and Glycera capitata. The impact of the dredged material disposal was evident through reductions in faunal abundance and biomass immediately after disposal. Burial of the fauna was hypothesized as the primary cause. Although the total spatial extent of the disposal impact was not discernible due to limited sampling, it is known that at least an area of 0.13 km<sup>2</sup> (the entire original disposal site sampling grid) experienced a 21 percent reduction in mean faunal abundance and a 25 percent reduction in biomass compared to predisposal values (Harman and Serwold, 1978).

Recolonization phases of the benthic macrofauna at the disposal site were reported as follows:

- A. Summer recruitment of opportunistic benthic macrofauna and annuals (3 months after disposal), followed by
- B. An increase in predatory polychaetes and a decline in opportunistic species (Harman and Serwold, 1978).

It was stressed that the composition of the biological community had not returned to predisposal conditions nine months after the disposal event.

Bingham (1978) provided additional numerical analyses to the data reported by Harman and Serwold (1978). The impact of the dredged material disposal was greatest at the central disposal site stations, with mean density and biomass remaining low for 9 months. In contrast, many stations at the margins of the site showed greater values for mean abundance, biomass, and number of species than were observed at the reference stations.

Tatam and Johnson (1978) summarized the overall dredged material disposal project for Elliott Bay. The discussion pertaining to the benthic macrofauna concluded that the major effect of the disposal was physical, not chemical. The authors concluded that the most impacted central stations suffered no permanent damage since the mean number of species present increased from a low of three species immediately after disposal to 25 species after a period of 9 months. However, mean biomass and abundances remained depressed after the disposal event.

#### Overview of present conditions

The most abundant taxa of the subtidal macrofauna observed during the present study were similar to those observed previously (Harman and Serwold, 1978). Tables 7, 8, and 9 list the dominant taxa ranked in order of abundance, biomass, and frequency of occurrence, respectively, based on the data from the three study cruises.

In general, the macrofauna of the area are deposit feeders. The most abundant polychaetes exhibit feeding characteristics which are dependent on their motility, morphology of feeding structures, and food sources. Table 10 describes possible feeding guild characteristics of the predominant polychaetes in Elliott Bay. Motile, surface and sub-surface deposit feeders are the predominant characteristics of these polychaetes. The predominant pelecypods, Axinopsida serricata and Macoma carlottensis, are also deposit feeders (Harman and Serwold, 1978; Fauchald and Jumars, 1979).

TABLE 7. RANKING OF MOST COMMON TAXA FROM CRUISES BY ABUNDANCE

Taxa #	Taxa	Rank			Mean Abundance <sup>(2)</sup>		
		May 79	Oct 79	May 80	May 79	Oct 79	May 80
175	<u>Axinopsida serricata</u>	1	1	1	270	294	227
065	<u>Capitellidae spp.</u>	2	4	2	58	40	69
085	<u>Euclymeninae spp.</u>	3	3	5	51	52	39
106	<u>Paraonella spinifera</u>	4	5	4	36	29	44
185	<u>Macoma carlottensis</u>	5	2	3	25	189	54
108	<u>Aricidea cf. lopezi</u>	6	6	6	17	16	19
203	<u>Cossuridae sp.</u>	7	8	10	16	11	8
019	<u>Lumbrineris luti</u>	8	9	9	10	8	9
151	<u>Amphipoda spp.</u>	9	7	8	9	14	11
193	<u>Nuculana minuta</u>	10	23	26	9	2	1
125	<u>Prionospio cirrifera</u>	11	13	14	8	6	5
074	<u>Chaetozone setosa</u>	12	15	16	7	5	3
007	<u>Glycera capitata</u>	13	37	17	4	1	3
025	<u>Nephtys ferruginea</u>	14	11	7	4	6	16
204	<u>Ostracoda spp.</u>	15	14	13	3	5	6
126	<u>Polydora hamata</u>	21	10	11	2	7	8
056	<u>Amphicteis scaphobranchiata</u>	17	12	33	2	6	1
192	<u>Nucula tenuis</u>	16	16	22	3	4	2
191	<u>Nemocardium centifilosum</u>	37	17	25	1	3	1
123	<u>Prionospio steenstrupi</u>	20	18	31	2	3	1
271	<u>Cumacea spp.</u>	18	19	15	2	3	3
159	<u>Mitrella gouldi</u>	32	20	36	1	3	1
176	<u>Cardiomya oldroydi</u>	39	21	29	1	2	1

(1) Taxa # is the computer code assigned to each individual taxa.

(2) Mean Abundance #'s/0.1m<sup>2</sup> = Sum of particular taxa abundance for all replicates divided by number of replicates for particular cruise.

TABLE 8. RANKING OF MOST COMMON TAXA FROM CRUISES BY BIOMASS

Taxa <sup>(1)</sup> #	Taxa	Rank			Mean Biomass <sup>(2)</sup>		
		May 79	Oct 79	May 80	May 79	Oct 79	May 80
175	<u>Axinopsida serricata</u>	1	1	2	.81	.97	.85
065	<u>Capitellidae spp.</u>	2	2	4	.79	.83	.69
226	<u>Mopaldia intermedia</u>	3	6	1	.74	.28	1.09
085	<u>Euclymeninae spp.</u>	4	3	5	.49	.45	.30
122	<u>Laonice cirrata</u>	5	5	6	.38	.31	.22
222	<u>Arhynchite pugettensis</u>	6	14	12	.25	.08	.07
185	<u>Macoma carlottensis</u>	7	4	3	.20	.44	.76
031	<u>Onuphis iridescens</u>	8	8	9	.14	.18	.13
007	<u>Glycera capitata</u>	9	9	10	.10	.17	.12
006	<u>Glycera americana</u>	10	35	93	.09	.02	<.01
013	<u>Goniada brunnea</u>	11	13	8	.07	.09	.16
184	<u>Macoma alaskansis</u>	12	27	20	.06	.03	.04
089	<u>Praxiella gracilllis</u>	13	21	31	.06	.04	.02
087	<u>Nicomache lumbricalis</u>	14	-(3)	97	.06	-(3)	<.01
181	<u>Lucinoma annulata</u>	15	70	19	.06	<.01	.04
177	<u>Compsomyax subdiaphana</u>	17	7	23	.05	.24	.03
191	<u>Nemocardium centifilosum</u>	19	10	11	.04	.15	.12
084	<u>Asychis similis</u>	32	11	37	.02	.12	.01
145	<u>Cerabratulus sp.</u>	20	12	7	.04	.10	.16
192	<u>Nucula tenuis</u>	22	15	22	.04	.07	.04
193	<u>Nuculana minuta</u>	26	16	26	.03	.07	.03

66

(1) Taxa # is the computer code assigned to each individual taxa.

(2) Mean Biomass g/0.1 m<sup>2</sup> = Sum of particular taxa wet weight for all replicates divided by number of replicates for particular cruise.

(3) Not found in this cruise.

TABLE 9. RANKING OF MOST COMMON TAXA FROM CRUISES BY FREQUENCY OF OCCURRENCE

Taxa #	Taxa	Rank			Frequency of Occurrence		
		May 79	Oct 79	May 80	May 79	Oct 79	May 80
019	<u>Lumbrineris luti</u>	1	1	2	100	100	100
106	<u>Paraonella spinifera</u>	2	7	4	100	98	98
108	<u>Aricidea cf. topezi</u>	3	10	5	100	91	98
175	<u>Axinopsida serricata</u>	4	5	6	100	100	98
065	<u>Capitellidae spp.</u>	5	2	1	98	100	100
085	<u>Euclymeninae spp.</u>	6	3	3	98	100	100
185	<u>Macoma carlottensis</u>	7	6	7	98	100	98
151	<u>Amphipoda spp.</u>	8	4	8	97	100	97
007	<u>Glycera capitata</u>	9	54	10	95	28	90
203	<u>Cossuridae sp.</u>	10	12	11	92	90	88
125	<u>Prionospio cirrifera</u>	11	11	14	90	90	83
074	<u>Chaetozone setosa</u>	12	17	17	88	74	77
192	<u>Nucula tenuis</u>	13	20	20	87	74	68
025	<u>Nephtys ferruginea</u>	14	8	9	85	97	92
056	<u>Amphicteis scaphobranchiata</u>	15	9	27	77	95	60
191	<u>Nemocardium centifilum</u>	35	13	32	38	84	52
031	<u>Onuphis iridescens</u>	20	14	28	63	78	55
204	<u>Ostracoda spp.</u>	18	15	21	70	78	68
146	<u>Cerabratulus sp.</u>	17	27	12	72	64	85
270	<u>Copepoda spp.</u>	26	74	13	53	19	85

(1) Taxa # is the computer code assigned to each individual taxa.

(2) Frequency of Occurrence = Sum of number of replicates in which particular taxa occurred divided by number of replicates for particular cruise. Expressed as a %.

TABLE 10. POSSIBLE FEEDING GUILD CHARACTERISTICS OF THE FIFTEEN MOST ABUNDANT POLYCHAETES FOUND IN ELLIOTT BAY

<u>Taxa</u>	<u>Family</u>	<u>Feeding Guild Characteristics</u> <sup>(1)</sup>	<u>References</u>
Capitellidae spp.	Capitellidae	Subsurface deposit feeder Surface deposit feeder, motile, other structures	Fauchald and Jumars (1979)
Euclymeninae spp.	Maldanidae	Subsurface deposit feeder, sessile, other structures	Fauchald and Jumars (1979)
<u>Paraonella spinifera</u>	Paraonidae	Herbivore, Surface deposit feeder, motile, other structures	Fauchald and Jumars (1979)
<u>Aricidea cf. lopezi</u>	Paraonidae	Herbivore, Surface deposit feeder, motile, other structures	Fauchald and Jumars (1979)
Cossuridae sp.	Cossuridae	Subsurface deposit feeder, motile, other structures	Fauchald and Jumars (1979)
<u>Lumbrineris luti</u>	Lumbrineridae	Subsurface deposit feeder, motile, jawed	Fauchald and Jumars (1979) Banse and Hobson (1968)
<u>Prionospio cirrifera</u>	Spionidae	Surface deposit feeder, discretely motile, tentaculate	Fauchald and Jumars (1979)
<u>Chaetozone setosa</u>	Cirratulidae	Surface deposit feeder, motile, tentaculate	Fauchald and Jumars (1979)
<u>Glycera capitata</u>	Glyceridae	Carnivore, facultative deposit feeder, motile, jawed	Fauchald and Jumars (1979)
<u>Nephtys ferruginea</u>	Nephtyidae	Carnivore, facultative deposit feeder, motile, jawed	Fauchald and Jumars (1979)

(Continued)



TABLE 10. (Continued)

<u>Taxa</u>	<u>Family</u>	<u>Feeding Guild Characteristics</u> <sup>(1)</sup>	<u>References</u>
<u>Amphicteis scaphobranchiata</u>	Ampharetidae	Surface deposit feeder, sessile, tentaculate	Fauchald and Jumars (1979)
<u>Syllis alternata</u>	Syllidae	Carnivore, motile, jawed	Fauchald and Jumars (1979)
<u>Prionospio steenstrupi</u>	Spionidae	Surface deposit feeder, sessile, tentaculate	Fauchald and Jumars (1979)
<u>Polydora hammata</u>	Spionidae	Facultative filter feeder, facultative surface deposit feeder, discretely motile, tentaculate	Fauchald and Jumars (1979)
<u>Nephtys</u> spp (juvenile)	Nephtyidae	Carnivore, facultative deposit feeder, motile, jawed (highly speculative)	Fauchald and Jumars (1979)

(1) Feeding guild characteristics defined as (1) food sources, (2) motility, and (3) morphology of feeding structures (other structures = structures other than jawed, pumping, tentaculate; usually eversible sac-like pharynges) as defined by Fauchald and Jumars (1979).

A comparison of the results of the previous study to present results is presented in Table 11. Abundances for selected taxa are compared to values reported by Harman and Serwold (1978). The taxa abundances of the stations at the corners of the original grid from the June 1976 sampling were selected to provide a comparison with less impacted stations. The most notable change was the dramatic increase in the abundance of Macoma carlottensis in October 1979. This increase was also documented by Malins et al. (1980) for other Elliott Bay stations not associated with the disposal site and for other embayments in Puget Sound and, therefore, appeared to be an areawide occurrence. A statistical comparison using the Wilcoxon two-sample test was performed for these taxa, comparing the data from the May 1979 and May 1980 cruises. The results indicated higher abundances in 1979 for the Euclymeninae and higher abundances in 1980 for Macoma carlottensis (statistically significant at the 1 percent level).

TABLE 11. COMPARISON OF SELECT TAXA MEAN ABUNDANCES, JUNE 1976 TO MAY 1980

Taxa	Mean Abundance, #'s/0.1 m <sup>2</sup>			
	June 1976 (1)	May 1979 (2)	October 1979 (3)	May 1980 (2)
<u>Axinopsida serricata</u>	145	270	294	227
<u>Macoma carlottensis</u>	28	25	189	54
Capitellidae <sup>(4)</sup>	11	58	40	69
Euclymeninae <sup>(5)</sup>	9	51	52	39

(1) 1976 values reported by Harman and Serwold (1978) for corner stations 1, 4, 13, 16; n = 12, 12, 12, 11, respectively.

(2) n = 60 for all.

(3) n = 58 for all.

(4) Referenced as Mediomastus californiensis and Heteromastus filibranchus in Harman and Serwold (1978).

(5) Referenced as Euclymene zonalis in Harman and Serwold (1978).

The total number of taxa identified for each cruise (not the mean number of taxa per station) is shown below:

<u>Cruise</u>	<u>Total Number of Taxa</u>
February 1979	147
May 1979	143
October 1979	155
May 1980	140

No significant differences were noted in the total numbers of taxa associated with the disposal site stations compared to the surrounding stations. Among these many taxa, the majority were present in low abundances, biomass, and percent occurrence compared to a relatively few dominant taxa. In light of this dominance and because very little ecological information existed for the majority of the rarer taxa, subsequent analyses were limited to the dominant organisms.

### Mapping

Mapping of the biological data was conducted to provide preliminary evaluation of the spatial trends in taxa abundances and biomasses. As previously described, two methods of mapping were used. Geometric contour maps were used to formulate testable hypotheses regarding spatial patterns in taxa abundances and biomasses in the study area. However, for purposes of visual representation of the biological data, contour mapping may oversimplify spatial patterns by ignoring small-scale variability in values and may present a biased picture. Therefore, the computer method of mapping, as described earlier in this report, was selected for display since it does not rely on mean values, nor does it necessitate interpolation of values between samples. A typical map produced by this technique is shown in Figure 43, the spatial abundance of the polychaete family Capitellidae. The plot suggests that higher abundances occur within and in the immediate proximity of the original sampling grid. The results of the mapping analysis for taxa abundances and biomasses are summarized in Tables 12, 13, and 14 for the May 1979, October 1979, and May 1980 cruises, respectively. These results are based on the subjective evaluation of whether



TABLE 12. RESULTS OF MAPPING ANALYSIS FOR  
SELECT TAXA FROM MAY 1979 CRUISE

<u>Taxa #</u>	<u>Taxa</u>	<u>Apparent Abundance</u>	<u>Central Tendency Biomass</u>
175	<u>Axinopsida serricata</u>	Yes	Yes
065	Capitellidae spp.	Yes	Yes
085	Euclymeninae spp.	Yes	Yes
106	<u>Paraonella spinifera</u>	Yes	Yes
185	<u>Macoma carlottensis</u>	Yes	Yes
108	<u>Aricidea cf. lopezi</u>	Yes	No
203	Cossuridae sp.	Yes	Yes
019	<u>Lumbrineris luti</u>	No	No
151	Amphipoda spp.	No	No
193	<u>Nuculana minuta</u>	No	No
125	<u>Prionospio cirrifera</u>	No	No
074	<u>Chaetozone setosa</u>	Yes	Yes
007	<u>Glycera capitata</u>	No	No
025	<u>Nephtys ferruginea</u>	No	No
204	Ostracoda spp.	No	No
122	<u>Laonice cirrata</u>	No	No
056	<u>Amphicteis scaphobranchiata</u>	Yes	No
192	<u>Nucula tenuis</u>	No	No
031	<u>Onuphis irridescens</u>	No	No

TABLE 13. RESULTS OF MAPPING ANALYSIS FOR SELECT TAXA FROM OCTOBER 1979 CRUISE

<u>Taxa #</u>	<u>Taxa</u>	<u>Apparent Central Tendency</u> <u>Abundance</u>	<u>Biomass</u>
175	<u>Axinopsida serricata</u>	Yes	Yes
065	<u>Capitellidae spp.</u>	Yes	No
085	<u>Euclymeninae spp.</u>	Yes	Yes
106	<u>Paraonella spinifera</u>	No	No
185	<u>Macoma carlottensis</u>	Yes	Yes
108	<u>Aricidea cf. lopezi</u>	Yes	Yes
203	<u>Cossuridae sp.</u>	Yes	Yes
019	<u>Lumbrineris luti</u>	No	No
151	<u>Amphipoda spp.</u>	Yes	Yes
193	<u>Nuculana minuta</u>	No	No
125	<u>Prionospio cirrifera</u>	No	No
074	<u>Chaetozone setosa</u>	Yes	Yes
007	<u>Glycera capitata</u>	Yes	Yes
025	<u>Nephtys ferruginea</u>	Yes	Yes
204	<u>Ostracoda spp.</u>	No	No
126	<u>Polydora hamata</u>	No	No
056	<u>Amphicteis scaphobranchiata</u>	Yes	Yes
192	<u>Nucula tenuis</u>	No	No
191	<u>Nemocardium centifilosum</u>	No	No
123	<u>Prionospio steenstrupi</u>	Yes	No
271	<u>Cumacea spp.</u>	No	No
159	<u>Mitrella gouldi</u>	No	Yes
176	<u>Cardiomya oldroydi</u>	No	No
031	<u>Onuphis irridesceus</u>	No	No
122	<u>Laonice cirrata</u>	No	No
005	<u>Dorvillea pseudorubrovittata</u>	No	No
021	<u>Ninoe gemmea</u>	No	No
089	<u>Praxiella gracilis</u>	No	No
013	<u>Goniada brunnea</u>	No	No
177	<u>Compsomyax subdiaphana</u>	No	No
084	<u>Asychis similis</u>	No	No

TABLE 14. RESULTS OF MAPPING ANALYSIS FOR SELECT TAXA FROM MAY 1980 CRUISE

<u>Taxa #</u>	<u>Taxa</u>	<u>Apparent Abundance</u>	<u>Central Tendency Biomass</u>
175	<u>Axinopsida serricata</u>	Yes	Yes
065	<u>Capitellidae spp.</u>	No	Yes
085	<u>Euclymeninae spp.</u>	Yes	No
106	<u>Paraonella spinifera</u>	Yes	Yes
185	<u>Macoma carlottensis</u>	No	Yes
108	<u>Aricidea cf. topezi</u>	No	No
203	<u>Cossuridae sp.</u>	Yes	Yes
019	<u>Lumbrineris luti</u>	No	No
151	<u>Amphipoda spp.</u>	No	No
193	<u>Nuculana minuta</u>	No	No
125	<u>Prionospio cirrifera</u>	Yes	No
074	<u>Chaetozone setosa</u>	No	No
007	<u>Glycera capitata</u>	Yes	Yes
025	<u>Nephtys ferruginea</u>	No	No
204	<u>Ostracoda spp.</u>	No	No
126	<u>Polydora hamata</u>	No	No
056	<u>Amphicteis scaphobranchiata</u>	No	No
192	<u>Nucula tenuis</u>	No	No
031	<u>Onuphis irridesceus</u>	No	No
122	<u>Laonice cirrata</u>	No	No
271	<u>Cumacea spp.</u>	Yes	No
054	<u>Exogone lourei</u>	No	No
270	<u>Copepoda spp.</u>	No	No
146	<u>Nemertea sp.</u>	Yes	No
013	<u>Goniada brunnea</u>	Yes	Yes
191	<u>Nemocardium centifilosum</u>	No	No
010	<u>Nephtys punctata</u>	No	No
030	<u>Lumbrineris californiensis</u>	No	No
181	<u>Lucionoma annulata</u>	No	No
184	<u>Macoma alaskansis</u>	No	No
112	<u>Pectinaria granulata</u>	Yes	No

the mapping indicated a central tendency, i.e., higher values of the parameters in the vicinity of the disposal site which was located at the center of the sampling grid. Those taxa which demonstrated an apparent central tendency for at least two of the three cruises for abundance and/or biomass are the common bivalves Axinopsida serricata and Macoma carlottensis; the polychaete families Capitellidae and Cossuridae; the subfamily Euclymeninae; and the polychaete species Paraonella spinifera, Aricidea cf. lopezi, Chaetozone setosa, and Glycera capitata. The hypotheses that these taxa (and possibly others) did in fact exist at higher abundances and biomasses within and near the dredged material were tested explicitly by Wilcoxon two-sample tests, as discussed later in this section.

### Cluster analysis

Cluster, or numerical classification analysis, was conducted to form spatial groupings of the stations based on similarities in the abundances and biomasses of the taxa. While providing no statistical inferences, cluster analysis does provide an objective method of segmenting the data by comparing the interrelationships of a large number of parameters.

These computations were run including the most common organisms (Tables 7 and 8). Cluster analysis was performed on both abundance and biomass data for each cruise, considering each sample (station replicate) as a separate spatial location. Cluster analysis was also performed with these same data, but using both mean and median values of the three replicates collected at each station. Table 15 summarizes the 28 cluster analyses performed for the biological data. Cluster analysis was also performed on the February 1979 (reconnaissance) cruise data; however, groupings were not similar to subsequent cruise results, probably due to the errors in the February data discussed earlier. The results are discussed below for each cruise.

May 1979 cruise data. The following discussion demonstrates how the results of the cluster analysis were used to develop hypotheses concerning the spatial distribution of taxa abundances and biomasses within and near the disposal grid. Figure 44 shows the cluster



TABLE 15. SUMMARY OF CLUSTER ANALYSES PERFORMED ON BIOLOGICAL DATA

<u>Cruise</u>	<u>Individual Sample* Abundances</u>	<u>Mean Station Abundances</u>	<u>Median Station Abundances</u>	<u>Individual Sample* Biomasses</u>	<u>Mean Station Biomasses</u>	<u>Median Station Biomasses</u>
May 1979	C2C1 <sup>xx</sup> (60,17)	C2MC (20,17)	C2MDC (20,17)	C2W1 (60,17)	C2MW (20,17)	C2MDW (20,17)
October 1979	C3C1 (58,21) C3C2 (58,18)	C3MC (20,21)	C3MDC (20,21)	C3W1 (58,21) C3W2 (58,18) C3W3 (58,18)	C3MW (20,21) C3WM (20,18)	C3MDW (20,21) C3WMD (20,18)
May 1980	C4C1 (60,19) C4C2 (60,15)	C4MC (20,19)	C4MDC (20,19)	C4W1 (60,19) C4W2 (60,15) C4W3 (60,17)	C4MW (20,19) C4WM (60,17)	C4MDW (20,19) C4WMD (20,14)

xxLetter Codes refer to specific cluster analysis outputs which are keyed to particular groupings in subsequent figures. Example: C2MC = Cruise 2 Mean Count (Abundances); MD = Median, W = Weights (Biomasses). Numbers in parentheses refer to the cluster matrix size, indicating the number of samples and number of taxa, respectively. Example: (60,17) indicates 60 stations (replicates) with 17 taxa per station.

\*Individual sample = station replicates.

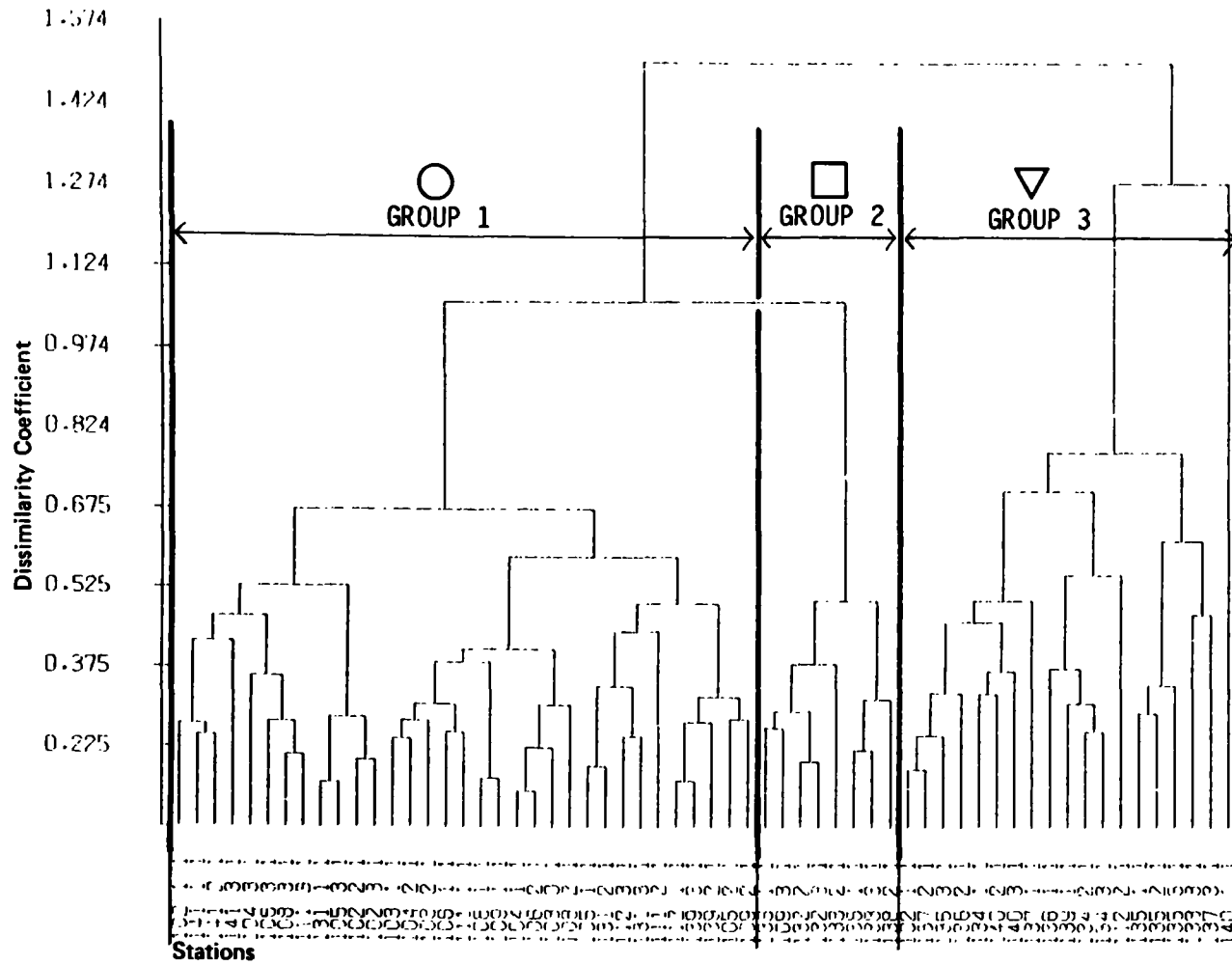

Figure 44a. Cluster Analysis Dendrogram for Samples (station replicates) of May 1979 Macrofauna Abundances, Code C2C1

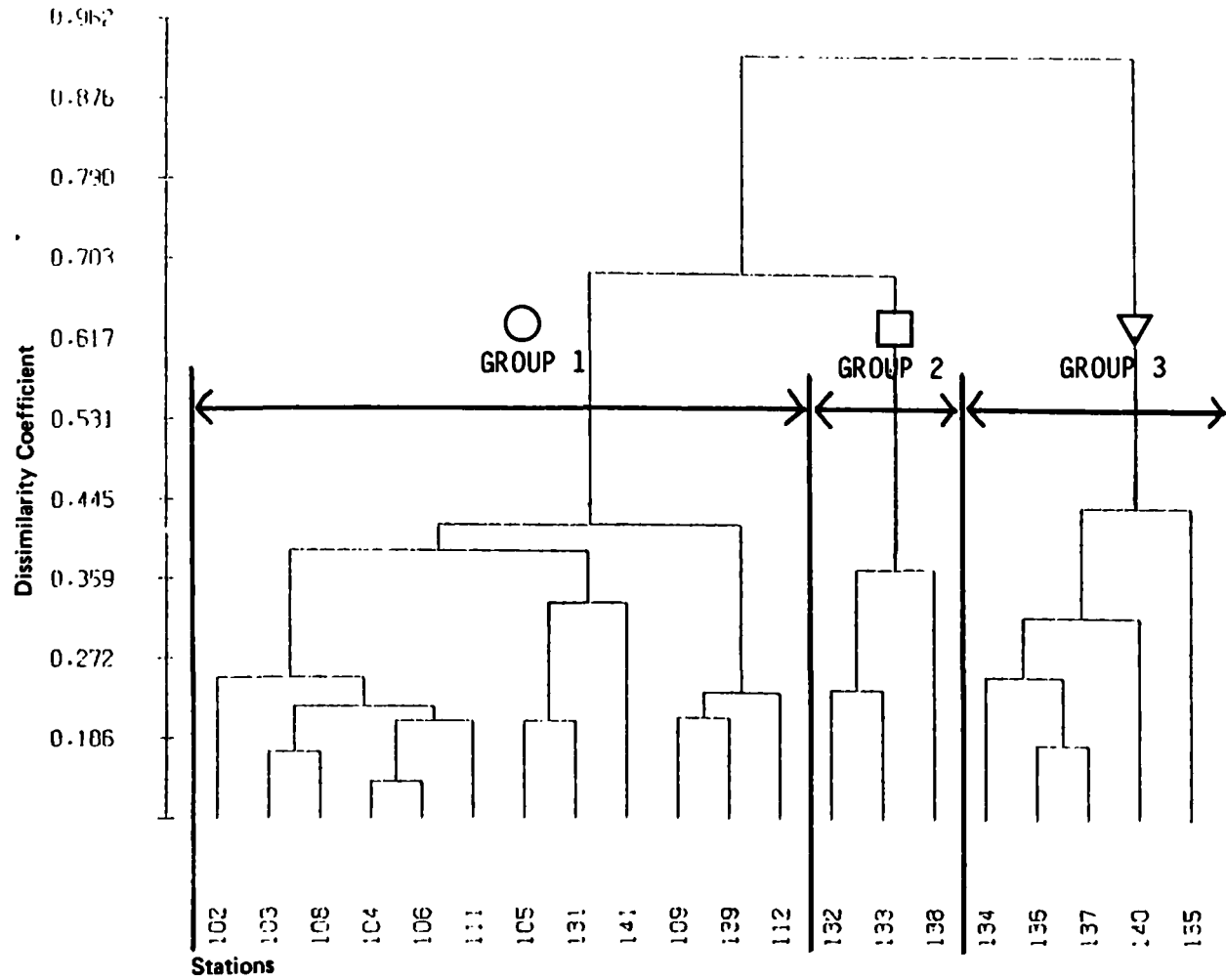

Figure 44b. Cluster Analysis Dendrogram for Station Means of May 1979 Macrofauna Abundances, Code C2MC

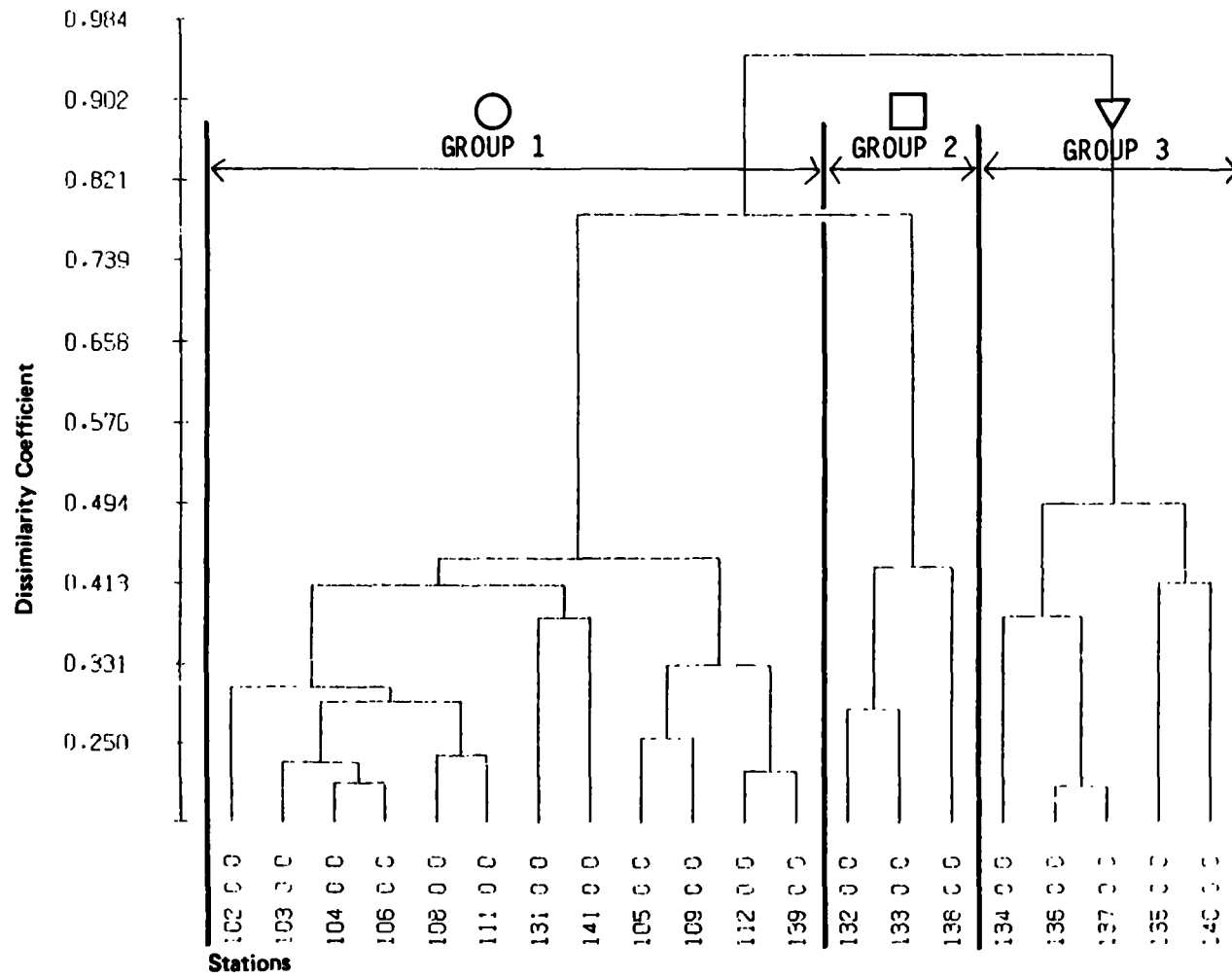

Figure 44c. Cluster Analysis Dendrogram for Station Medians of May 1979 Macrofauna Abundance, Code C2MC

analysis outputs for May 1979 individual samples (station replicates), mean station, and median station abundances. Although the dendrograms were objectively drawn in the computer analyses, the determination of the numbers of groups was subjective and depended on the selection of the dissimilarity coefficient. The station groupings resulting from this cluster analysis are shown in Figure 45. Three major spatial groupings were evident for the station replicate data (Figure 45a) and were similar to the groupings obtained using the station means and medians (Figure 45b).

These three examples (based on station replicates, means and medians) of cluster analysis suggest that taxa abundances for samples in and immediately around the original sampling grid (group 1, Figures 44 and 45) were more similar to each other than to the samples peripheral to the grid (groups 2 and 3), and, thus, that the disposal site contains an assemblage of macrofauna different from surrounding areas. Two obvious exceptions to this hypothesis were stations 139 and 141, which were clustered in group 1 (Figure 45b).

The sample and station groupings resulting from the remaining 25 cluster analyses (Table 15) are summarized in Figures 46-50. The dendrogram outputs, which were the basis for these groupings, are shown in Appendix E.

Groupings based on station replicates for the biomasses from the May 79 cruise (Figure 46a) were not well separated spatially. However, groupings based on station mean and median biomasses (Figure 46b and c, respectively) were identical to those obtained from the abundances (Figure 45) with the exception of station 134. Thus, overall, both the abundance and biomass cluster analyses of the 17 most abundant taxa from the May 1979 cruise suggested that stations located within the original disposal site contain a macrofauna assemblage different from the surrounding area.

October 1979 cruise data. The results of the cluster analyses, using the 20 most common taxa and based on station replicates and mean and median values are shown in Figures 47 and 48 for abundances and biomasses, respectively. The data from this cruise did not yield as distinct spatial groupings as were obtained from the May 1979 data. In

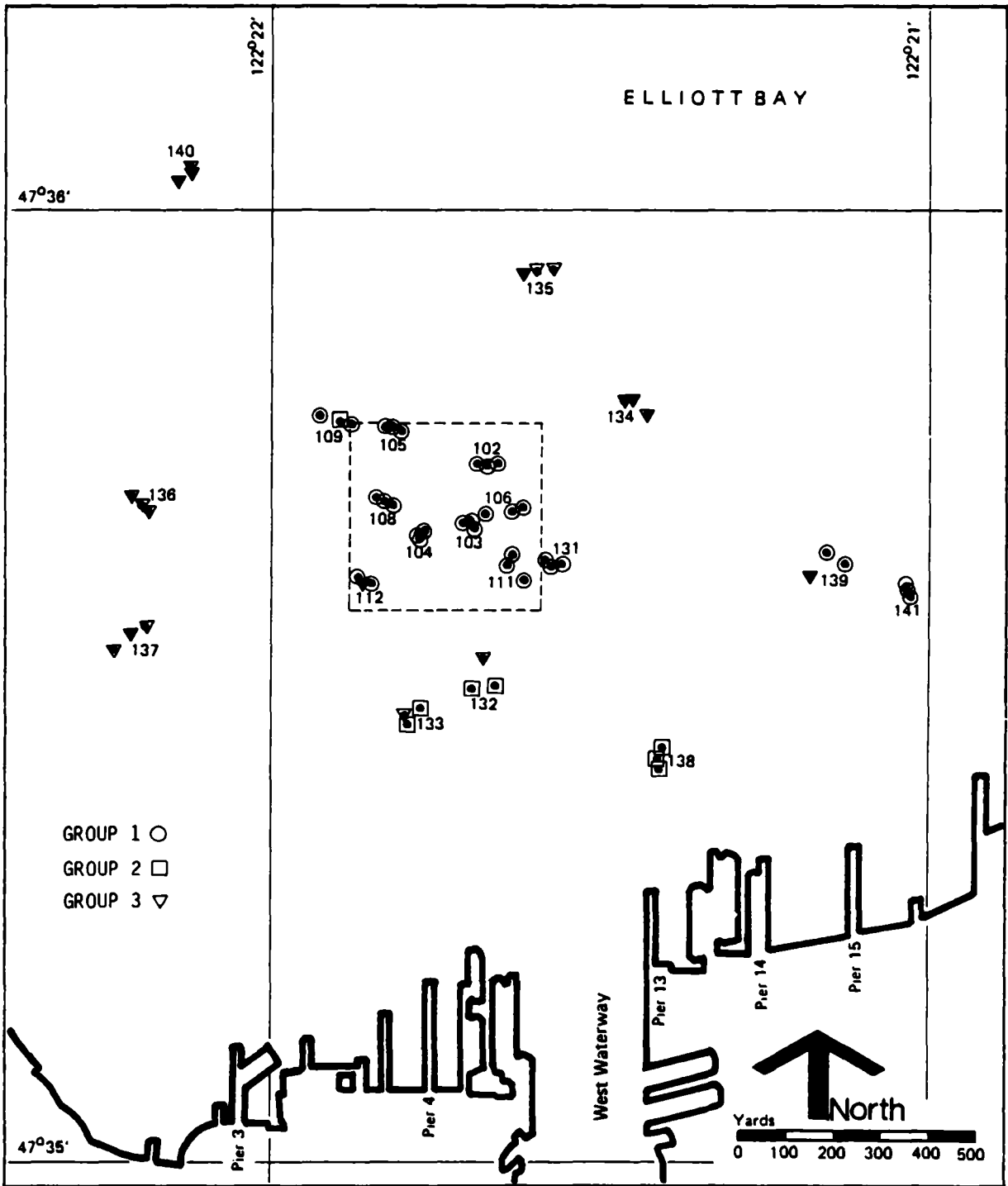

Figure 45a. Cluster Analysis Groupings for Samples (Station Replicates) of May 1979 Macrofauna Abundances, Code C2C1

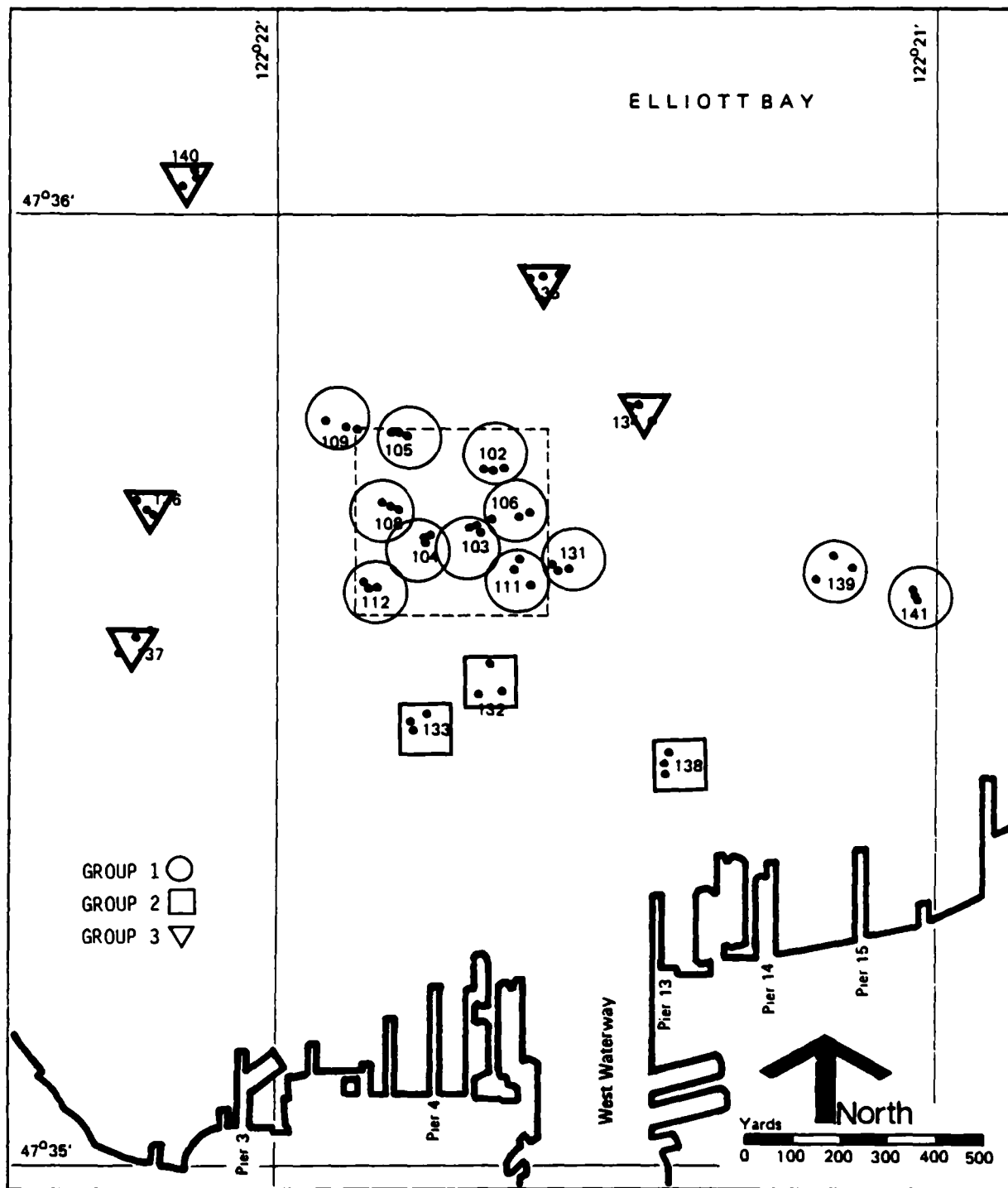

Figure 45b. Cluster Analysis Groupings for Station Means and Medians of May 1979 Macrofauna Abundances, Code C2MC

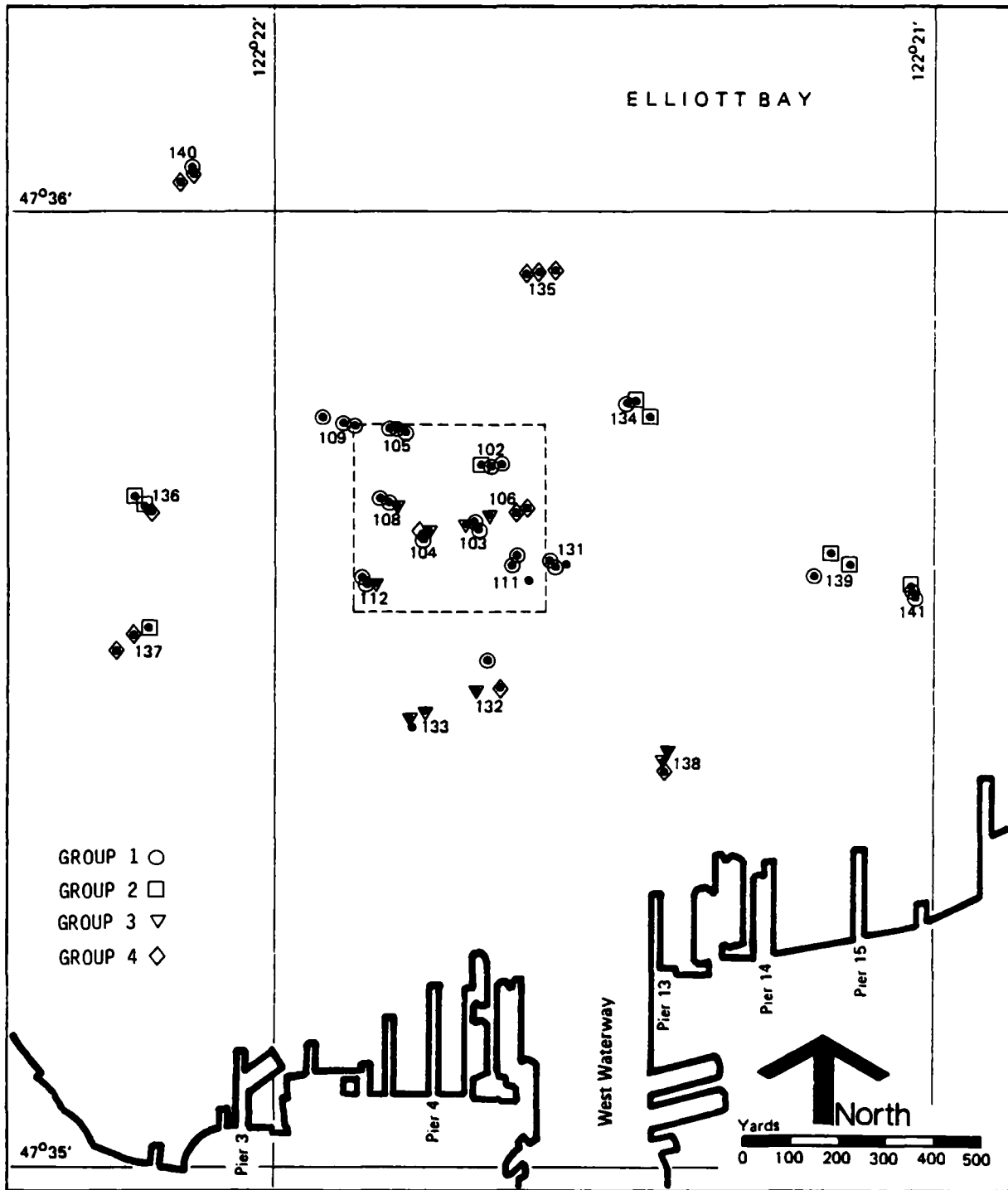

Figure 46a. Cluster Analysis Groupings for Samples (Station Replicates) of May 1979 Macrofauna Biomasses, Code C2W1



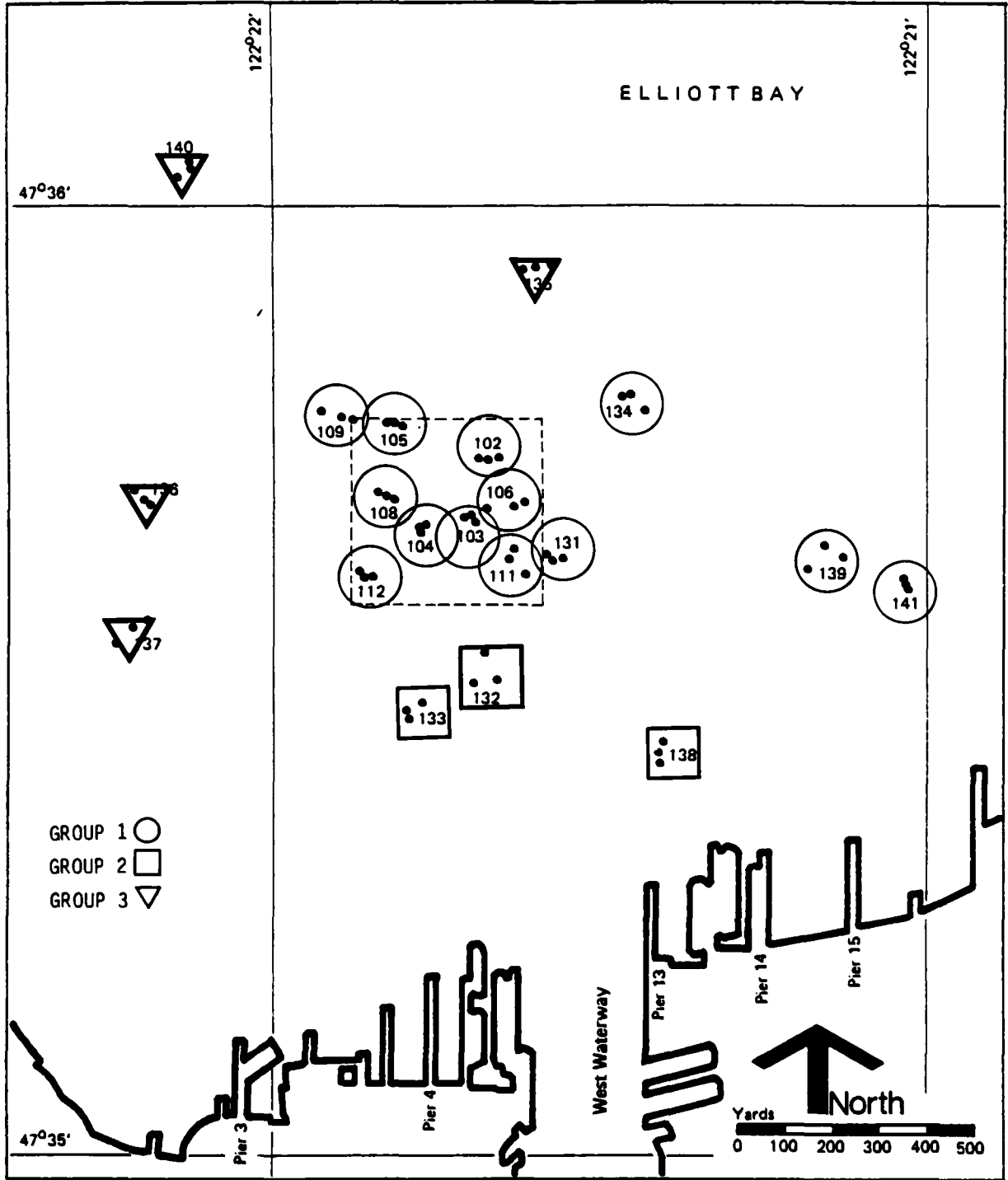

Figure 46b. Cluster Analysis Groupings for Station Means and Medians of May 1979 Macrofauna Biomasses, Codes C2MW and C2MDW

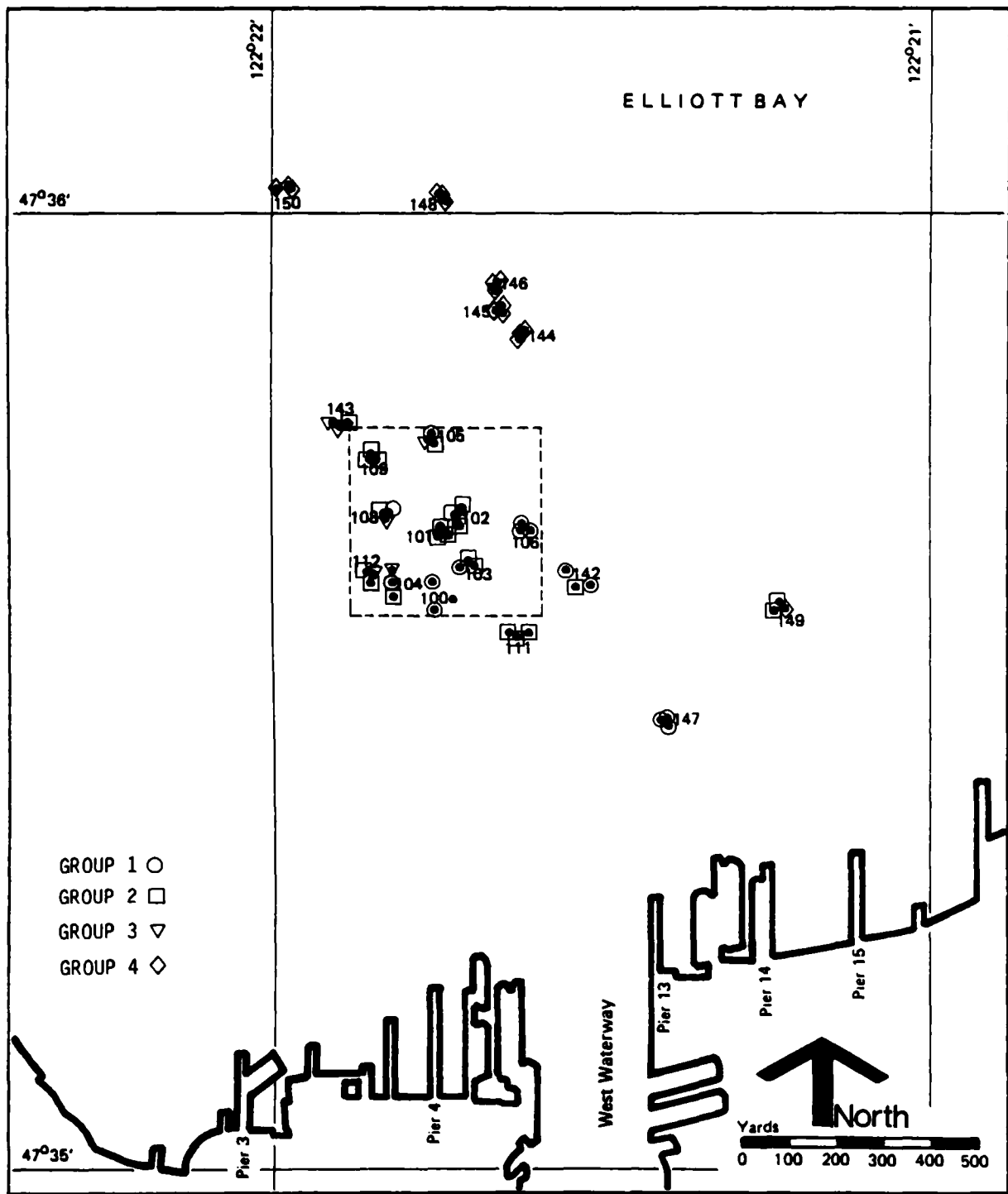

Figure 47a. Cluster Analysis Groupings for Samples (Station Replicates) of October 1979 Macrofauna Abundances, Code C3C1

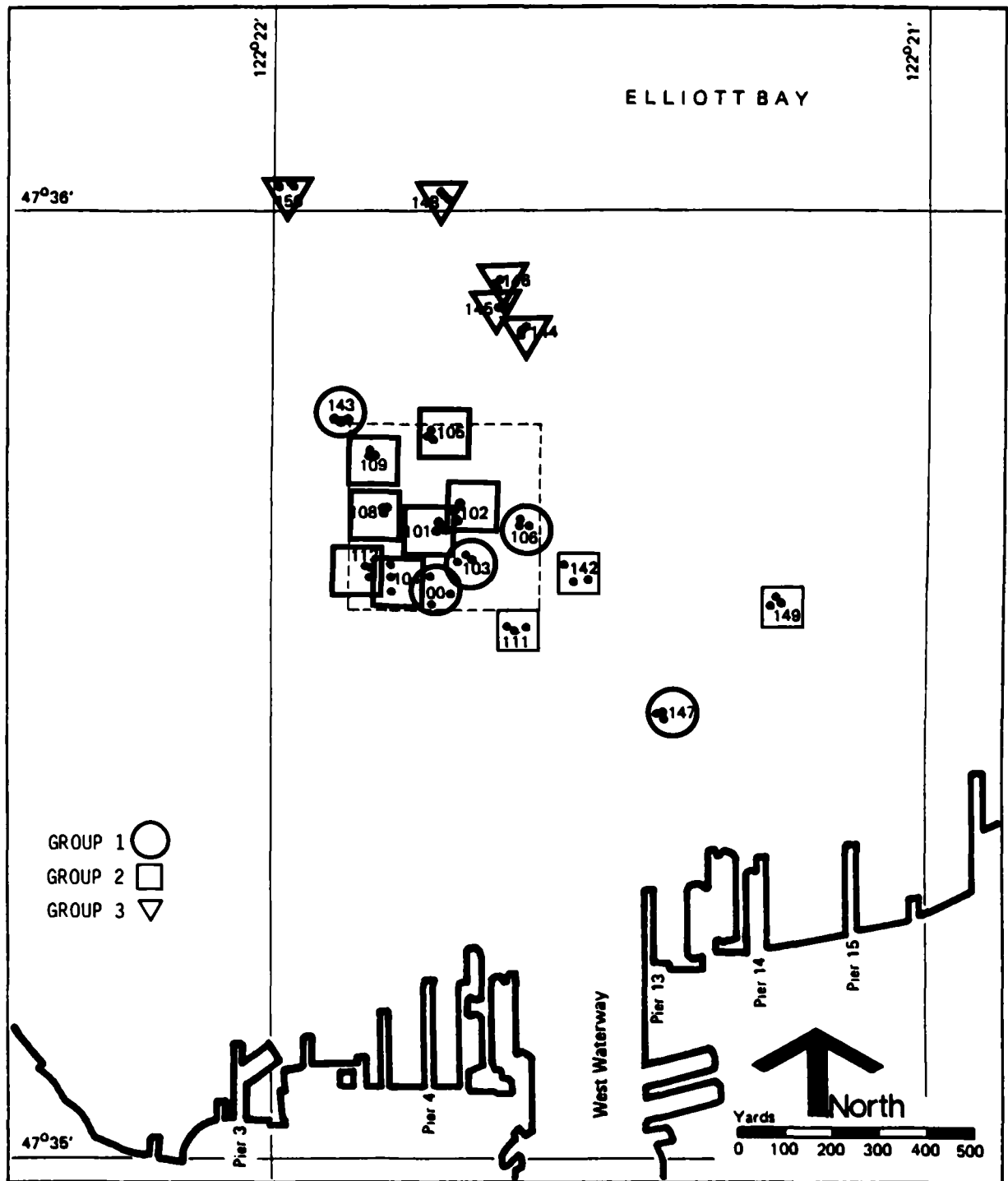

Figure 47b. Cluster Analysis Groupings for Station Means of October 1979 Macrofauna Abundances, Code C3MC

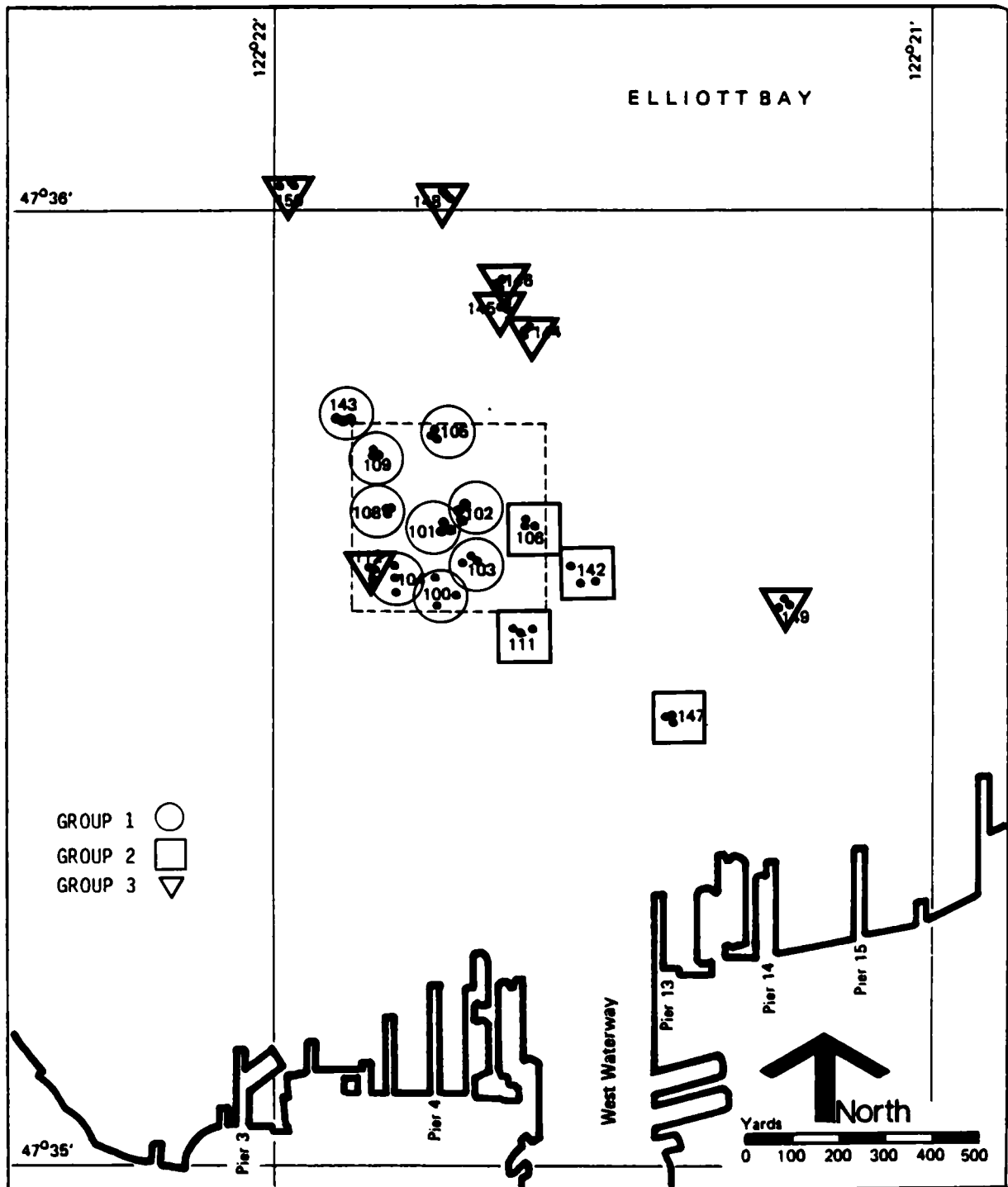

Figure 47c. Cluster Analysis Groupings for Station Medians of October 1979 Macrofauna Abundances, Code C3MDC

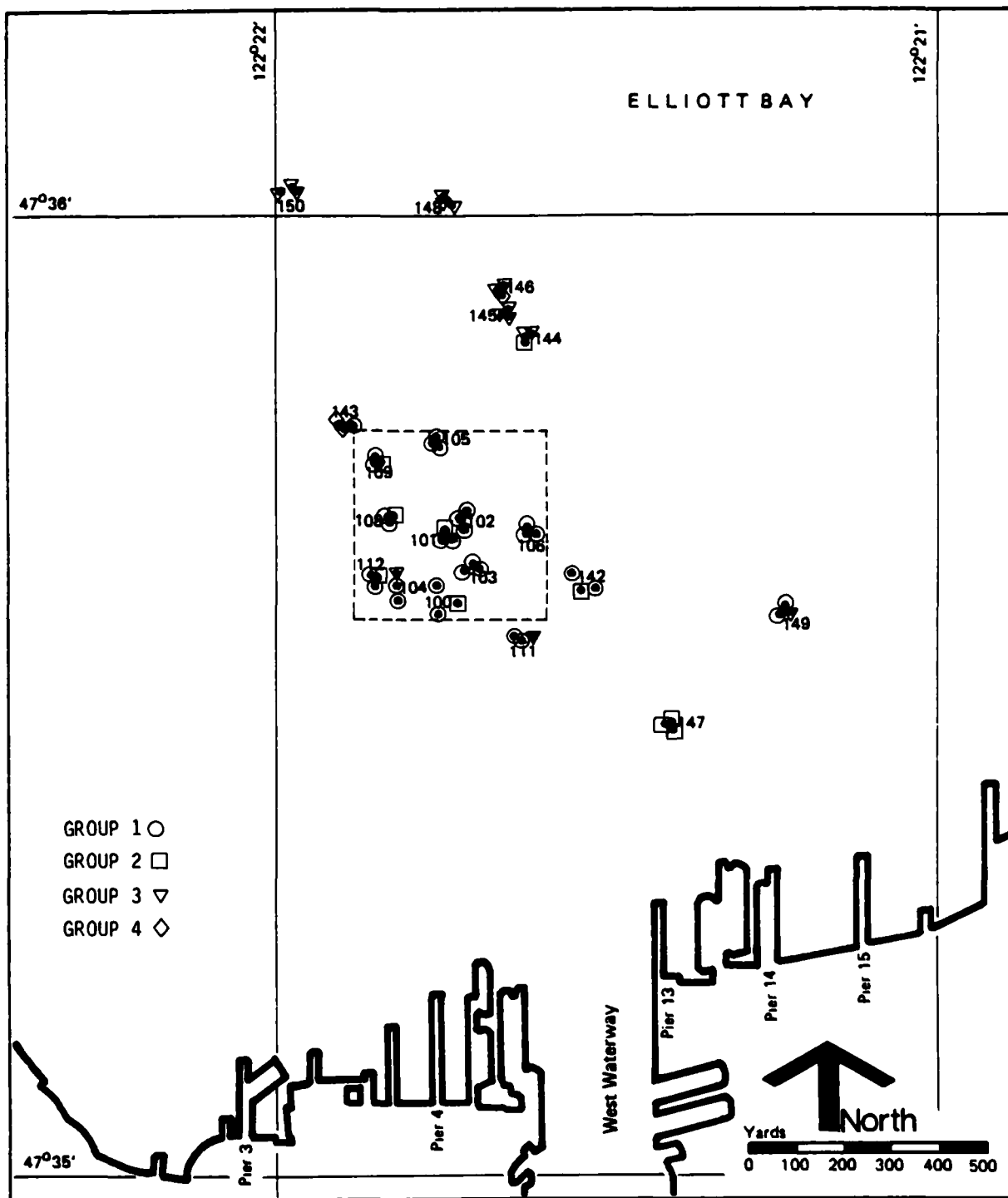

Figure 48a. Cluster Analysis Groupings for Samples (Station Replicates) of October 1979 Macrofauna Biomasses, Code C3W1

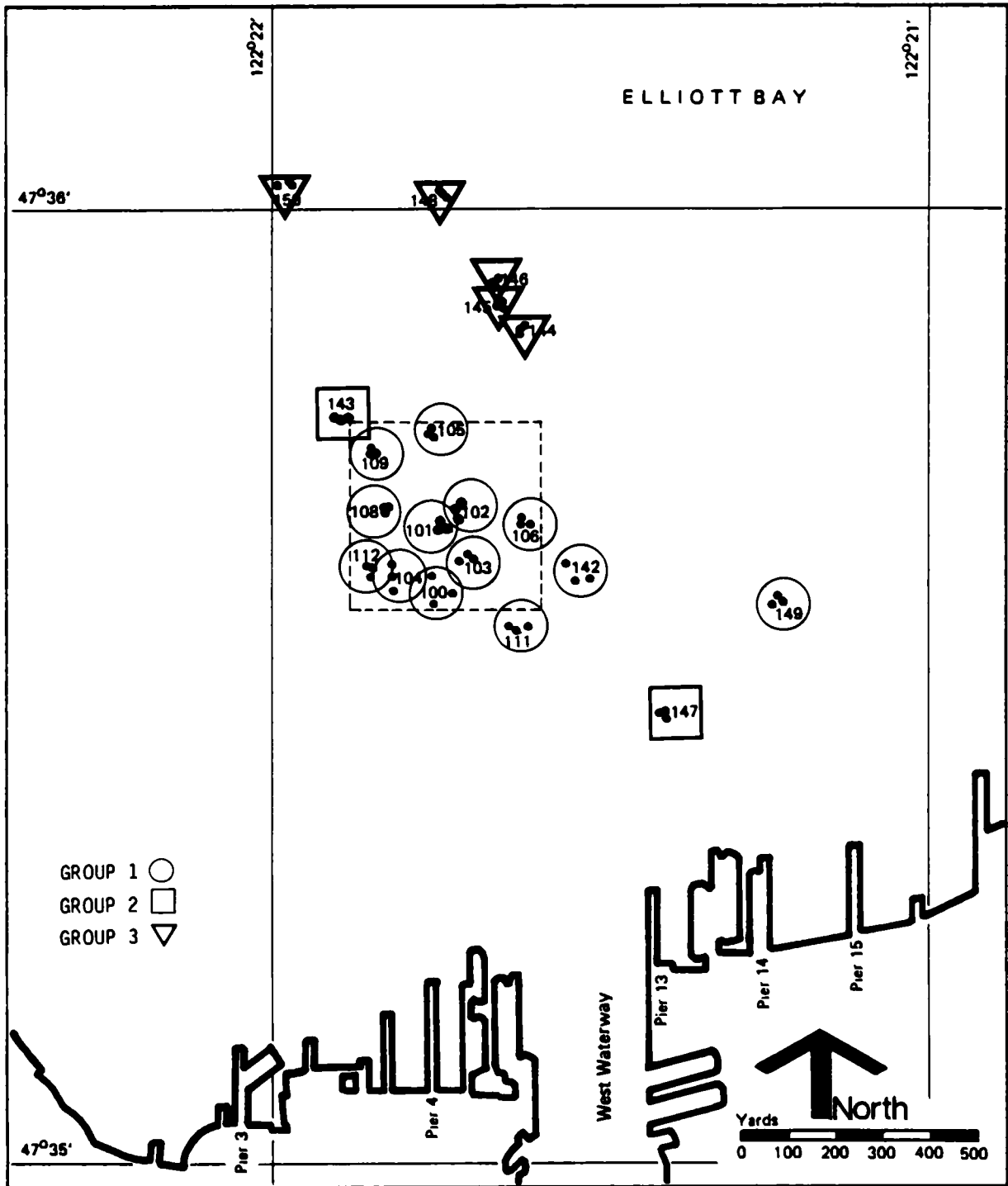

Figure 48b. Cluster Analysis Groupings for Station Means of October 1979 Macrofauna Biomasses, Code C3MW

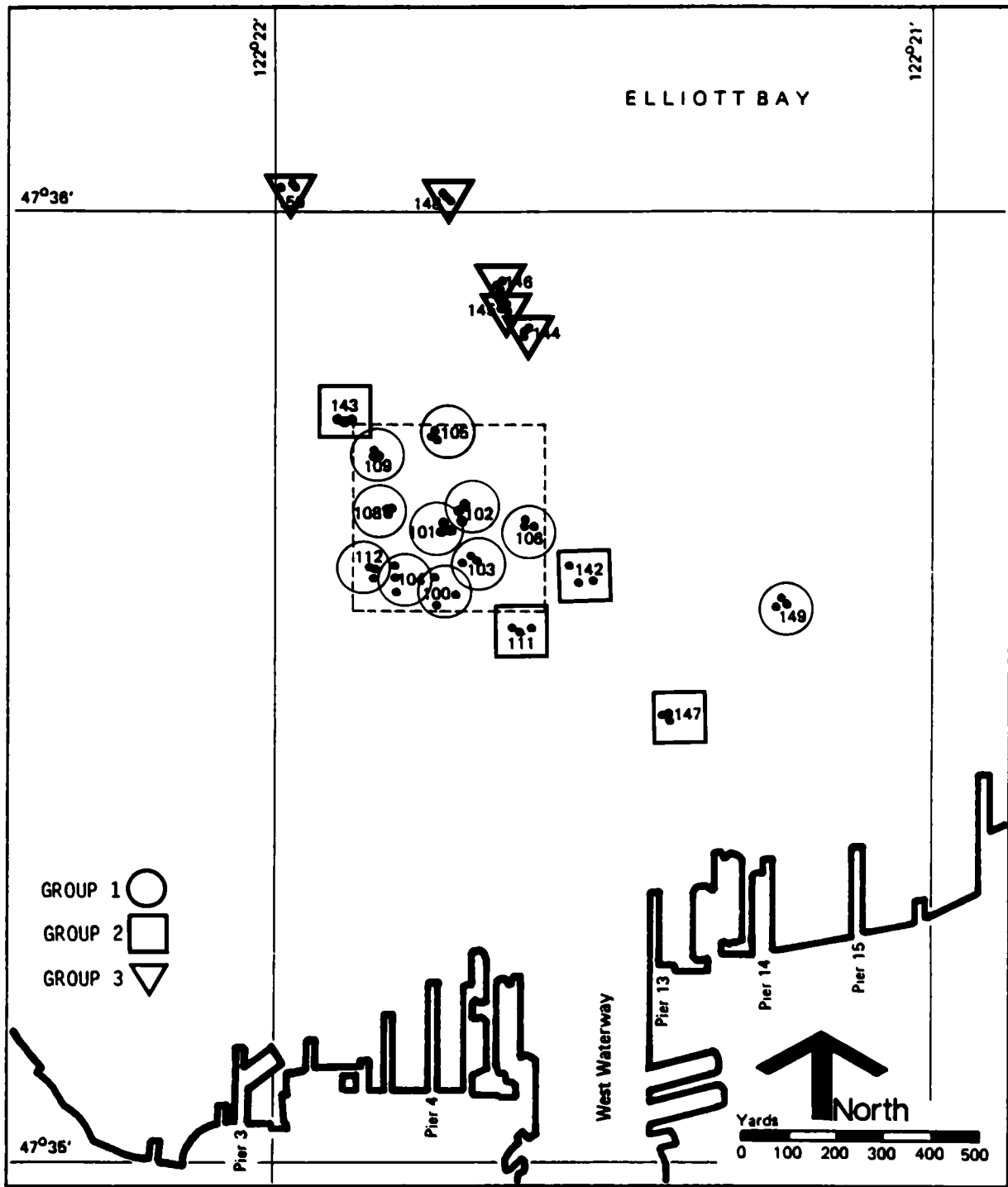

Figure 48c. Cluster Analysis Groupings for Station Medians of October 1979 Macrofauna Biomasses, Code C3MDW

particular, the stations located in the vicinity of the disposal site were not always grouped together while relatively consistent grouping of the more northerly stations (144, 145, 146, 148, and 150) was observed in both the abundance and biomass cluster analyses.

May 1980 cruise data. The results of the cluster analyses performed with the May 1980 cruise data are presented in Figures 49 and 50 based on abundances and biomasses, respectively. These analyses were similar to those performed with the data from the other cruises and were based on the 19 most common taxa.

As was the case with the October 1979 data, while a wholly consistent spatial grouping of disposal site stations was not obtained with either the abundance or biomass data, the data indicate that the assemblages at most of the stations at the disposal site and at a few peripheral stations were similar. As was also the case with the October data, the May 1980 data yielded consistent groupings of the stations to the north and east of the disposal site.

#### Conclusions of cluster analysis

The results of the cluster analyses agreed with the general indications obtained by mapping, i.e., that the disposal site macrofaunal community was characterized by different abundances and biomasses than seen in most of the stations from surrounding areas. Stations to the north and east of the disposal site generally exhibited the greatest similarities to the disposal site stations.

It should be noted, however, that the communities at both the disposal site and surrounding areas were dominated by the same taxa (see Tables 12-14). In addition, comparisons of the total number of taxa represented by the cluster groupings in October 1979 and May 1980 did not reveal any major differences among groups:

	<u>Station Grouping</u>	<u>Total No. of Taxa</u>
October 1979 Cruise	1†	140
	2	118
	3	109
	2+3	134
May 1980 Cruise	1††	72
	2	128
	3	83
	1+3	102

† Station groupings from abundance medians, Code C3MDC, Figure 47c.

†† Station groupings from abundance medians, Code C4MDC, Figure 49b.



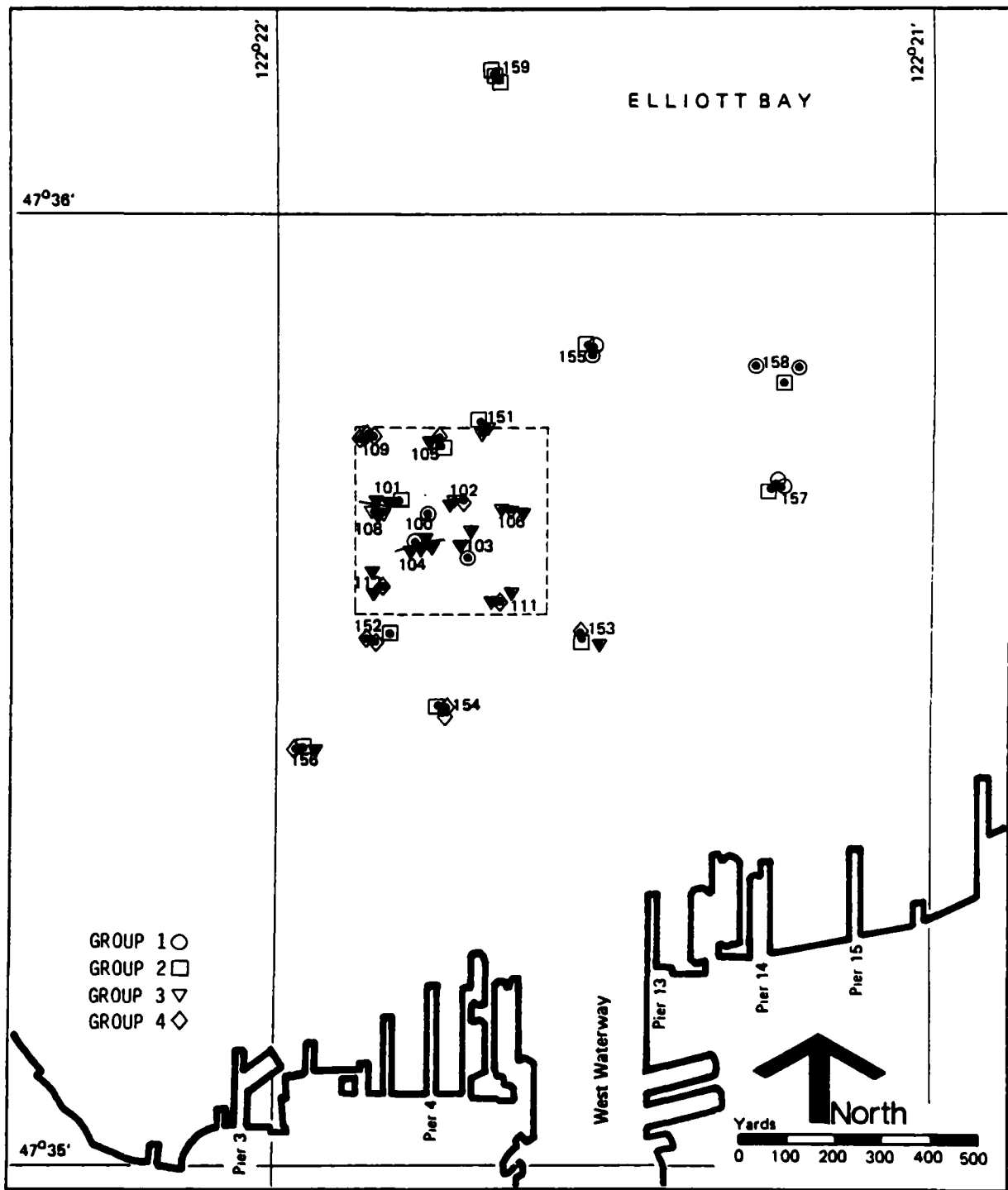

Figure 49a. Cluster Analysis Groupings for Sample (Station Replicates) of May 1980 Macrofauna Abundances, Code C4C1

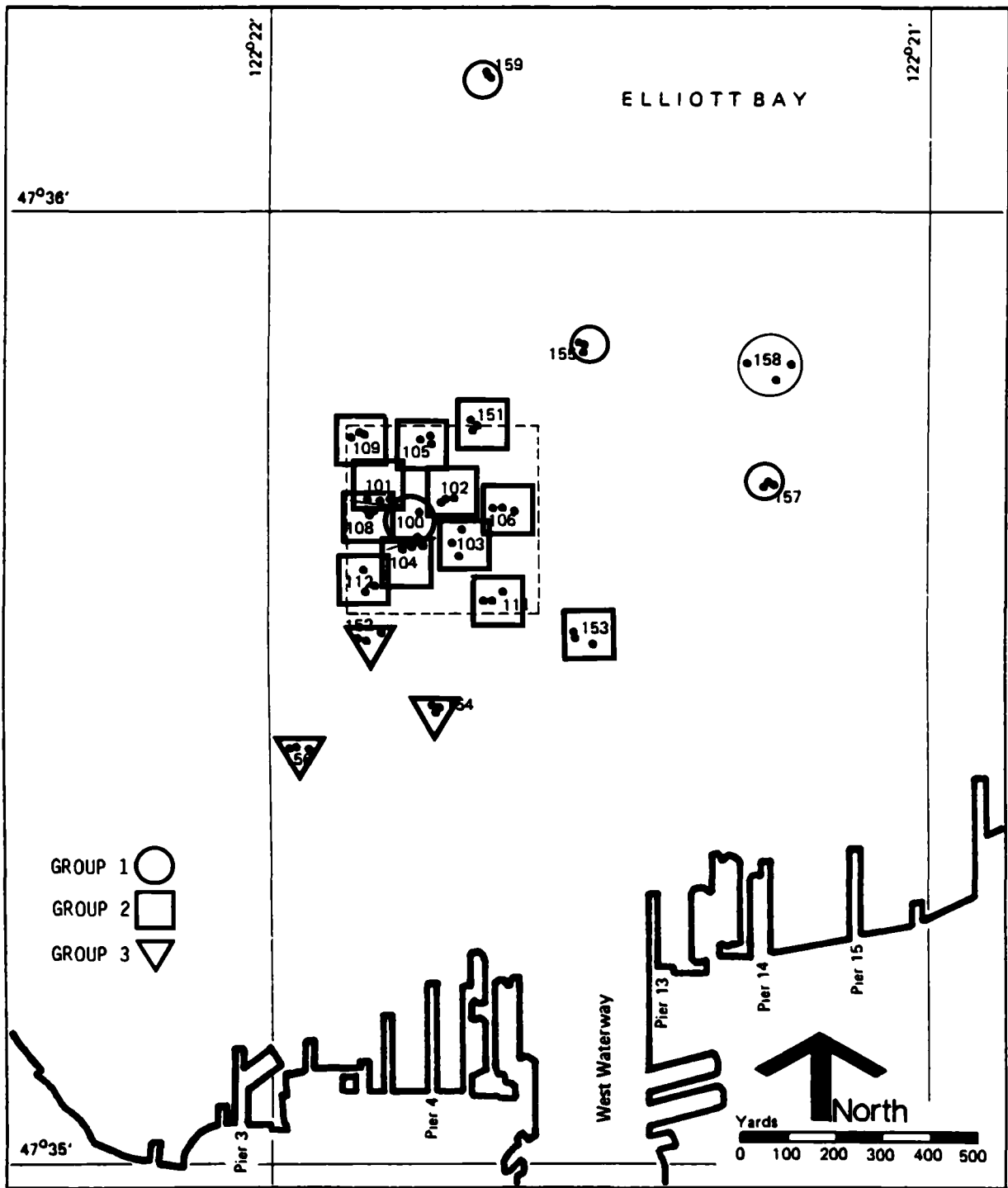

Figure 49b. Cluster Analysis Groupings for Station Medians of May 1980 Macrofauna Abundances, Code C4MDC

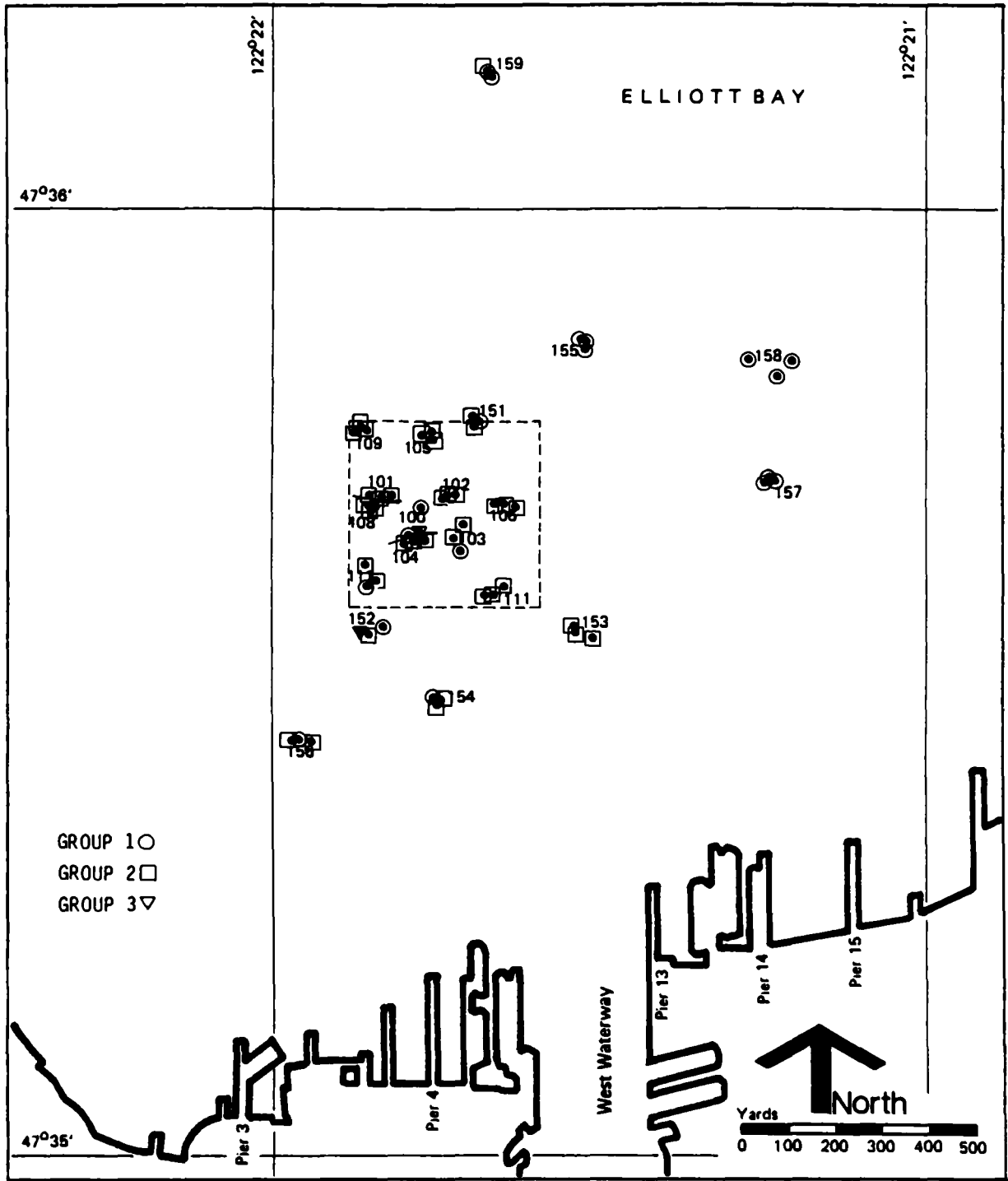

Figure 50a. Cluster Analysis Groupings for Sample (Station Replicates) of May 1980 Macrofauna Biomasses, Code C4W1

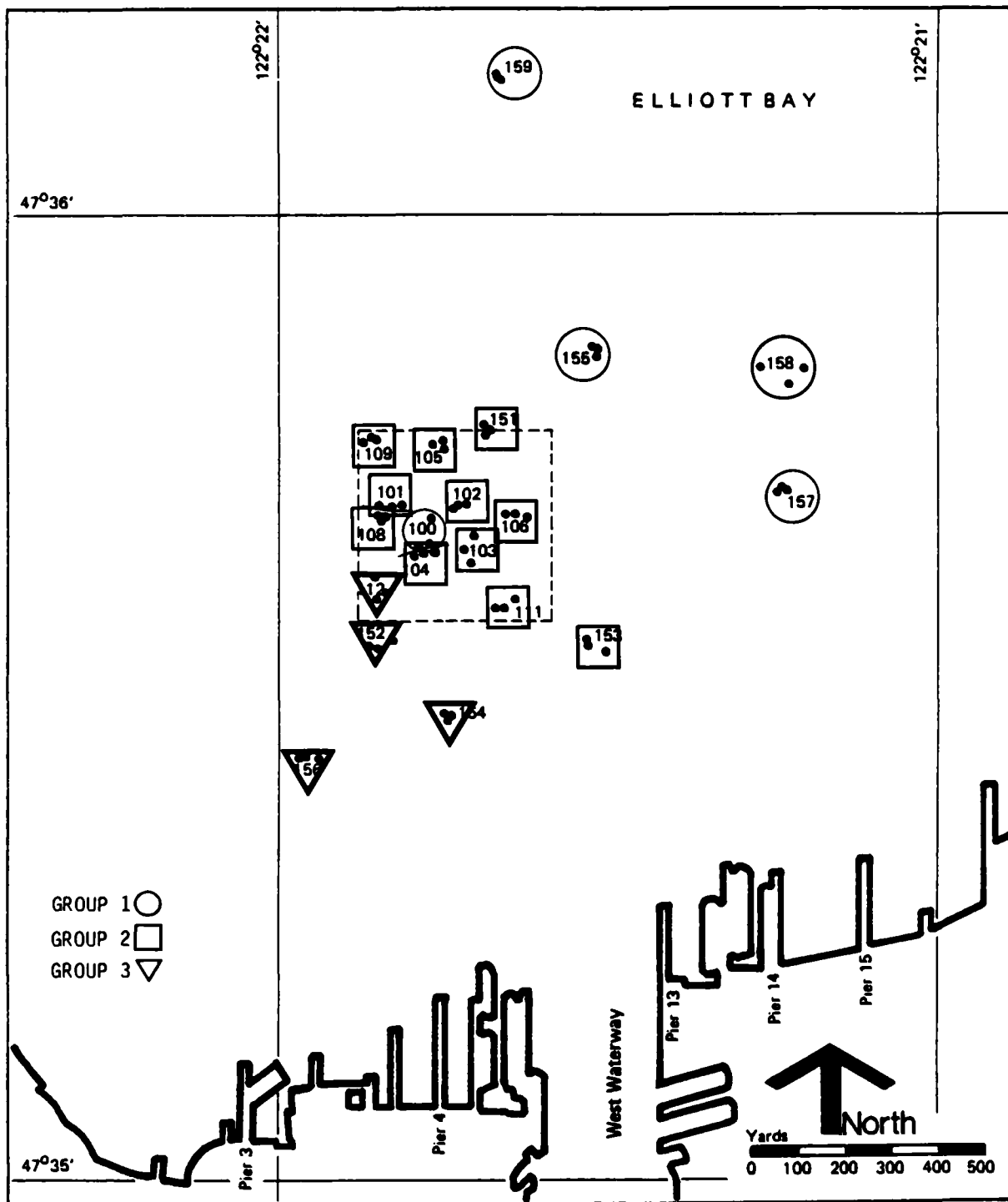

Figure 50b. Cluster Analysis Groupings for Station Medians of May 1980 Macrofauna Biomasses, Code C4MDW

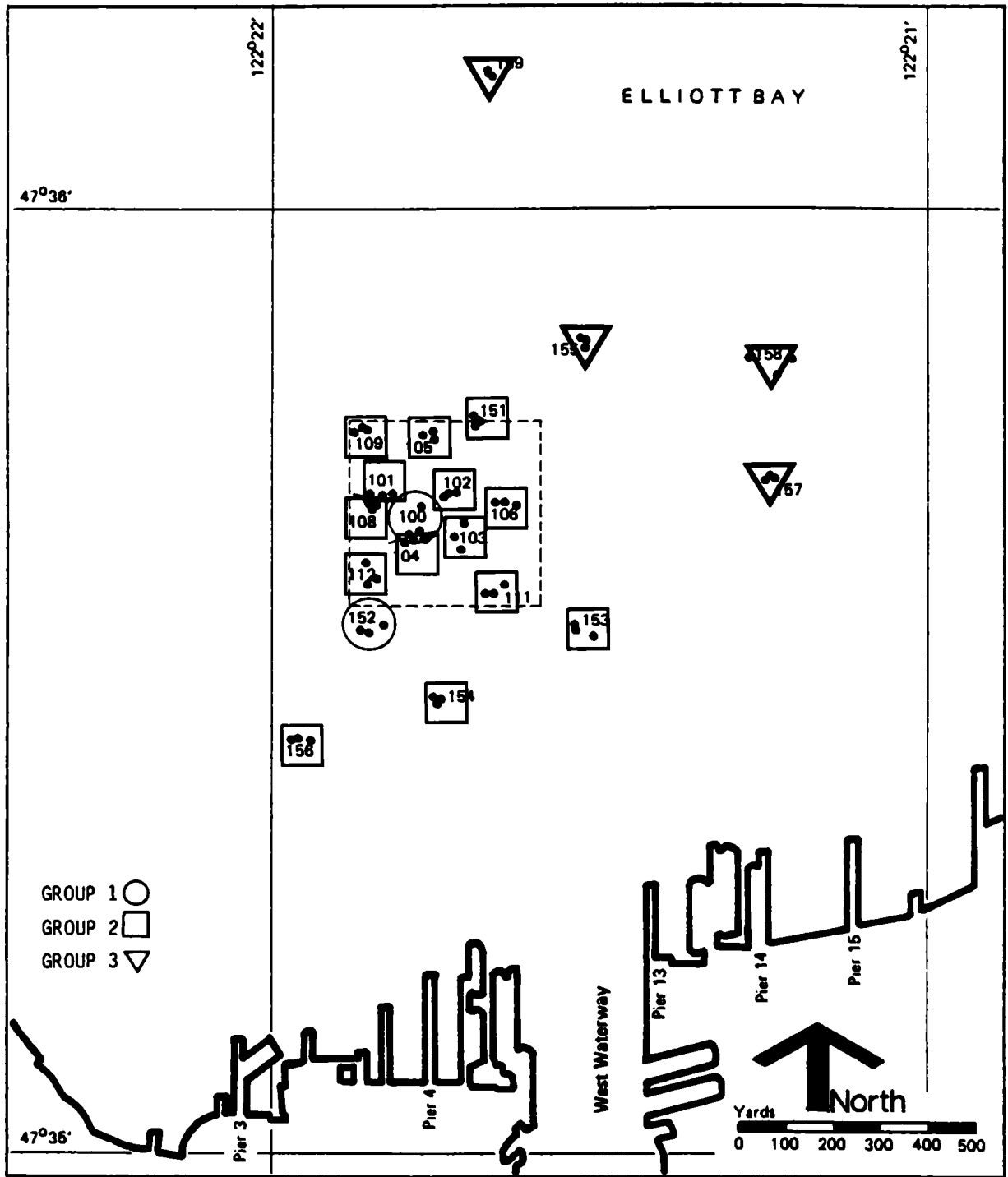

Figure 50c. Cluster Analysis Groupings for Station Means of May 1980 Macrofauna Biomasses, Code C4MW

### Spatial autocorrelation

Spatial autocorrelation analysis statistically tests the null hypothesis that taxa abundances are randomly distributed. The test calculation used in this study was weighted to be most sensitive to comparisons in taxa abundances among samples that were similar distances from the disposal site. The premise of this weighting was that any effects of dredged material would be greatest at the center of the site, with less effect occurring at stations located progressively more distant from the center.

Spatial autocorrelation analysis was performed using the abundances of 17 selected taxa measured in May 1979. Results (Table 16) showed that nine taxa were found to have one or both Moran's I and Geary's C significant at the  $\leq 1\%$  level. For five of these taxa, both test statistics were significant, which suggests that the abundances of these organisms were not randomly distributed in the study area.

Comparison of these results to the Wilcoxon two-sample test results showed that, of the nine taxa which had nonrandom abundance distributions, eight also had statistically higher abundances in station groupings within the proximity of the original grid. Similarly, of the eight taxa which exhibited random distributions, five exhibited no significant differences in abundances between station groupings on and off the grid. These results were consistent with the results of the cluster analysis, showing that the abundances of many of the selected species were statistically greater near the disposal site.

Due to the similarity in conclusions between spatial autocorrelation and the Wilcoxon two-sample tests (described below) and the fact that the Wilcoxon test went further in elucidating relationships by testing differences between specific station groupings, spatial autocorrelation was not performed for the other two study cruises.

### Wilcoxon two-sample test

The nonparametric, Wilcoxon two-sample test was conducted to determine whether or not individual taxa had statistically significant differences in abundances and/or biomasses between stations within and around the disposal site versus more distant stations. A nonparametric

TABLE 16. RESULTS OF SPATIAL AUTOCORRELATION ANALYSIS  
FOR SELECT TAXA ABUNDANCES OF THE MAY 1979 CRUISE

	Moran's I	Probability	Geary's C	Probability
	Expected 0.017		Expected 1.000	
<u>Axinopsida serricata</u>	0.593*	≤.00001	0.539*	≤.00001
Capitellidae spp.	0.328*	≤.00001	0.673*	≤.00050
Euclymeninae spp.	0.278*	≤.00001	0.678*	≤.00050
<u>Paraonella spinifera</u>	0.365*	≤.00001	0.714*	≤.00500
<u>Macoma carlottensis</u>	0.326*	≤.00001	0.731*	≤.00500
Cossuridae sp.	0.489*	≤.00001	0.675	≤.02500
<u>Lumbrineris luti</u>	0.057	≤.10000	0.919	>0.1
<u>Chaetozone setosa</u>	0.548*	≤.00001	0.777	≤.05000
<u>Nephtys ferruginea</u>	-0.013	>0.1	1.304	>0.1
<u>Amphicteis scaphobranchiata</u>	0.118*	≤.01000	0.987	>0.1
<u>Nuculana minuta</u>	0.074	≤.02500	0.688	>0.1
<u>Glycera capitata</u>	0.065	≤.10000	0.891	>0.1
Ostracoda spp.	0.083	≤.05000	.822	>0.1
<u>Laonice cirrata</u>	0.125*	≤.01000	0.827	≤.05000
<u>Nucula tenuis</u>	0.071	≤.10000	0.815	≤.05000
<u>Aricidea cf lopezi</u>	0.266	≤.10000	1.028	>0.1

\*statistically significant at the ≤1% level, when each test (taxa) considered separately.

test was used because it requires no assumptions of normally distributed populations. The test was run for several taxa per cruise using different station groupings established in the cluster analysis (Table 17). This approach compared groupings based on both station mean and individual replicate data.

TABLE 17. SUMMARY OF WILCOXON TWO-SAMPLE TESTS PERFORMED ON THE BIOLOGICAL DATA

<u>Cruise/Reference to Figure in Text</u>	<u>Data Type</u>		<u>Station Groups Compared On Disposal Site vs Off</u>
	<u>Abundance</u>	<u>Biomass</u>	
May 1979/Fig. 45b	C2MC*		1 vs 2 + 3
May 1979/Fig. 46b		C2MW	1 vs 2 + 3
Oct. 1979/Fig. 47b	C3MC		1 + 2 vs 3
Oct. 1979/Fig. 47c	C3MDC		1 vs 2 + 3
Oct. 1979/Fig. 48b		C3MW	1 vs 2 + 3
Oct. 1979/Fig. 48c		C3MDW	1 vs 2 + 3
May 1980/Fig. 49b	C4MDC		2 vs 1 + 3
May 1980/Fig. 50b		C4MDW	2 vs 1 + 3

\* Letter codes refer to particular cluster analyses used to establish the station groupings for Wilcoxon analyses and cross-referenced to the figures in text noted in column 1.

The results of the analyses for select taxa are summarized in Table 18. The taxa selected for Table 18 were dominant in all cruises. The overall trend for most of these taxa was that they exhibited greater abundances and biomasses within the grid and its immediate proximity. Several other taxa, ranked high in abundance and biomass for one cruise (Tables 7 and 8), were also evaluated using the Wilcoxon two-sample test. A summary of results for these taxa is provided in Appendix E. By and large, the Wilcoxon tests confirmed the tendency toward higher abundances and biomasses apparent in the mapping (Tables 12-14).



TABLE 18. RESULTS OF WILCOXON TWO-SAMPLE TESTS  
FOR SELECT TAXA FROM GROUPS OF STATIONS

Station Groups Compared on Disposal Grid vs Off<sup>(1)</sup> -

Taxa #	Taxa	Difference Did Exist Between Groups <sup>(2)</sup> (Probability < 0.0100) <sup>(3)</sup>							
		May 1979 Cruise		October 1979 Cruise				May 1980 Cruise	
		Abundance (C2MC)	Biomass (C2MW)	Abundance (C3MC)	Biomass (C3MDC)	Biomass (C3MW)	Biomass (C3MDW)	Abundance (C4MDC)	Biomass (C4MDW)
175	<u>Axinopsida serricata</u>	Yes	Yes	Yes	Yes	Yes	Yes	Yes	Yes
65	<u>Capitellidae spp.</u>	Yes	Yes	Yes	No	Yes	Yes	Yes	No
85	<u>Euclymeninae spp.</u>	Yes	Yes	Yes	No	Yes	Yes	Yes	Yes
106	<u>Paraonella spinifera</u>	Yes	Yes	Yes	No	Yes	No	Yes	Yes
185	<u>Macoma carlottensis</u>	Yes	Yes	Yes	Yes	Yes	Yes	Yes	Yes
108	<u>Aricidea cf. lopezi</u>	No	No	Yes	Yes	Yes	Yes	Yes	No
203	<u>Cossuridae sp.</u>	Yes	Yes	Yes	Yes	Yes	Yes	Yes	Yes
025	<u>Nephtys ferruginea</u>	Yes	Yes	Yes	Yes	Yes	Yes	Yes	Yes
204	<u>Ostracoda spp.</u>	No	No	Yes	Yes	No	No	Yes	Yes
056	<u>Amphicteis scaphobranchiata</u>	Yes	Yes	No	Yes	No	Yes	---	---
019	<u>Lumbrineris luti</u>	No	No	No	No	Yes <sup>(5)</sup>	No	No	No
151	<u>Amphipoda spp.</u>	---	---	No	Yes	No	No	Yes	No
193	<u>Nuculana minuta</u>	No	No	---	---	---	---	---	---
125	<u>Prionospio cirrifera</u>	No	No	No	No	No	No	Yes	Yes
074	<u>Chaetozone setosa</u>	Yes	Yes	No	No	No	No	No	No
007	<u>Glycera capitata</u>	No	No	No	---	---	---	No	No
126	<u>Polydora hamata</u>	---	---	No	Yes	No	No	No	No
192	<u>Nucula tenuis</u>	No	No	Yes	No	No	No	---	---

(1) See Table 17 for Station Groups Compared - On Disposal Grid (vs) Off.

(2) Values were greater for station groups located on the disposal grid unless otherwise noted; see Table 17 for Data Type (abundance and biomass codes) and References to Figures.

(3) See Appendix E for actual probabilities (results from Wilcoxon two-sample test).

(4) Wilcoxon two-sample test not performed for this taxa.

(5) The biomass values were greater for station groups located off the disposal grid.

Several other comparisons of abundances and biomasses between smaller groups were performed using the Wilcoxon two-sample test to investigate the sensitivity of the cluster analysis for defining station groups which had abundances or biomasses distinguishable from the other groups. An overall trend (Table 19) was evident that comparisons between station groups which were both near and within the disposal site yield consistently fewer taxa exhibiting significant differences in abundance or biomass compared to comparisons between disposal site and distant stations. These results suggest that the major spatial differences existed between the disposal site and the more distant stations and that the selection of the station groups used for the primary statistical analysis (Table 18) was reasonable.

In summary, the results of the Wilcoxon two-sample tests showed that many of the dominant taxa exhibited significant differences in abundance and biomass between groups of stations selected from the cluster analysis results. These groupings tended to segregate the study area into one group consisting of stations within and near the dredged-material deposit and one or more additional groups of stations from the surrounding area. Therefore, from an overall perspective, it appears that the dominant taxa of the macrofaunal assemblage still exhibited effects from the dredged material disposal which occurred in early 1976. However, these effects were not the same as those documented on the site after disposal, i.e., reduction in abundance and biomass. These studies indicated that the long-term effect was that many dominant taxa exhibited greater abundances and biomasses within the dredged material compared to their abundances and biomasses in the surrounding "background" sediments. A similar increase in abundance and biomass was noted for many stations at the margins of the site in 1976 (Bingham, 1978).

#### Relationships of biological results to physical/chemical results

The nonparametric Kendall's coefficient of rank correlation test was performed on selected data sets to examine the degree of association between the biological and abiotic parameters.

TABLE 19. SUMMARY OF WILCOXON TWO-SAMPLE TEST RESULTS  
SHOWING SENSITIVITY OF CLUSTER ANALYSIS

<u>Code</u>	<u>Cruise and Groups Compared<sup>(1)</sup></u>	<u>Comparisons of Groups Near and Within Disposal Site - Percent of Taxa With Differences<sup>(2)</sup></u>	<u>Comparisons of Groups Near and Within Disposal Grid to Distant Station Groups - Percent of Taxa With Differences<sup>(2)</sup></u>
<u>May 1979 Cruise</u>			
C2MW	4 vs 5 and 4 vs 6	12	47
<u>October 1979 Cruise</u>			
C3MC	1 vs 3 and 1 vs 2	5	67
	2 vs 3 and 1 vs 2	5	52
C3MDC	1 vs 3 and 1 vs 2	14	62
	2 vs 3 and 1 vs 2	14	48
C3MW	1 vs 3 and 1 vs 2	10	29
	2 vs 3 and 1 vs 2	10	62
C3MDW	1 vs 3 and 1 vs 2	5	57
	2 vs 3 and 1 vs 2	5	38
<u>May 1980 Cruise</u>			
C4MDC	1 vs 2 and 2 vs 3	15	75
	1 vs 3 and 2 vs 3	15	35
C4MDW	1 vs 2 and 2 vs 3	10	60
	1 vs 3 and 2 vs 3	10	30

Footnotes:

- (1) See Table 17 for reference to Figures showing groups.  
(2) Percent of taxa showing significant differences (probability  $\leq 0.01$ ).  
See Appendix E for actual probabilities.

Several tests were performed using mean values of the biological, physical, and chemical data for each station. Station means were used because the biological and abiotic data were obtained from different samples; therefore, only the mean values obtained from the same station were considered comparable. The biological data included the mean abundances and biomasses of taxa which demonstrated differences in these parameters between stations within and near the disposal site and the distant stations (Table 18). The physical data included in the correlation analyses included mean phi size and percent sand of the surface sediments (t-CB). The chemical data included the mean total organic carbon (PTOC), total PCB (t-CB), and trichlorobiphenyl (3-CB) concentrations of the surface sediments. The results of these correlation analyses are summarized in Table 20. Significant correlations are illustrated by scatter plots in Appendix E.

May 1979 cruise. Mean abundances for only 2 of the 17 dominant taxa were correlated (at  $P < 0.01$ ) with any of the abiotic data. The polychaete Praxiella gracilis, categorized by Harman and Serwold (1978) as a large "climax species," was positively correlated with the percent sand; however, the weakness of this relationship is indicated by the correlation coefficient (Table 20). The poor correlation observed may have resulted primarily from the low abundance of this species (it was considered dominant due to its high biomass). The polychaete Paraonella spinifera, not identified in the earlier site study (Harman and Serwold, 1978), was weakly correlated with the percent total organic carbon (Table 20). Scatter plots of these correlations, typical of the data obtained in these analyses, are presented in Figures 51 and 52. The expected correlation between mean phi and percent sand noted in Table 20 was discussed earlier in this report.

October 1979 cruise. Mean abundances for 4 of the 21 dominant taxa were negatively correlated ( $P < 0.01$ ) with the mean phi size of the surface sediments (Table 20): the bivalves Nemocardium centifilum, categorized as a sensitive climax species of the deeper Puget Sound waters (Harman and Serwold, 1978), and Macoma carlottensis, a more resilient bivalve; and the crustacean taxa Amphipoda and Ostracoda. These bivalves and amphipods were also positively correlated with

TABLE 20. RESULTS OF THE KENDALL'S CORRELATION ANALYSIS BETWEEN BIOLOGICAL, PHYSICAL, AND CHEMICAL MEAN DATA -- MAY 1979, OCTOBER 1979, AND MAY 1980 CRUISES (1)

Biological Data		Physical Data			Chemical Data		
Taxa #	Taxa	Mean Phi	Percent Sand		PTOC	3-CB	t-CB
<u>May 1979 Cruise</u>							
089	<u>Praxiella gracilis</u>	- - - (2)	0.50 (19)	0.0038 <sup>(3)</sup>	- - -	- - -	- - -
106	<u>Paraonella spinifera</u>	- - -	- - -	- - -	0.44 (20)	0.0071	- - -
		x (4)	-0.67 (20)	<0.0001	- - -	- - -	- - -
<u>October 1979 Cruise</u>							
191	<u>Nemocardium centifilosum</u>	-0.49 (20)	0.0033	0.52 (20)	0.0017	- - -	- - -
025	<u>Nephtys ferruginea</u>	- - -	- - -	0.52 (20)	0.0015	- - -	- - -
108	<u>Aricidea cf. lopezi</u>	- - -	- - -	0.50 (20)	0.0020	- - -	- - -
151	<u>Amphipoda</u>	-0.49 (20)	0.0025	0.50 (20)	0.0020	- - -	- - -
192	<u>Nucula tenuis</u>	- - -	- - -	- - -	- - -	- - -	- - -
185	<u>Macoma carlottensis</u>	-0.45 (20)	0.0053	0.56 (20)	0.0005	-0.45 (19)	0.0076
204	<u>Ostracoda</u>	-0.53 (18)	0.0021	- - -	- - -	- - -	- - -
175	<u>Axinopsida serricata</u>	- - -	- - -	0.42 (20)	0.0094	- - -	- - -
203	<u>Cossuridae</u>	- - -	- - -	0.43 (20)	0.0086	- - -	- - -
		x	-0.73 (20)	<0.0001	- - -	- - -	- - -
<u>May 1980 Cruise</u>							
175	<u>Axinopsida serricata</u>	-0.48 (19)	0.0041	0.59 (19)	0.0005	0.43 (20)	0.0086
185	<u>Macoma carlottensis</u>	-0.43 (19)	0.0096	0.54 (19)	0.0013	- - -	- - -
025	<u>Nephtys ferruginea</u>	-0.44 (19)	0.0086	0.62 (19)	0.0002	- - -	- - -
065	<u>Capitellidae</u>	- - -	- - -	0.51 (19)	0.0025	- - -	- - -
146	<u>Nemertea</u>	- - -	- - -	0.48 (19)	0.0053	- - -	- - -
151	<u>Amphipoda</u>	-0.61 (19)	0.0003	0.66 (19)	0.0001	- - -	- - -
271	<u>Cumacea</u>	- - -	- - -	0.55 (19)	0.0015	- - -	- - -
		x	0.79 (19)	<0.0001	- - -	- - -	- - -

(1) See Appendix E for detailed analysis results.

(2) "- - -" indicates that relationship was not significant (probability >0.01).

(3) First value is Kendall's tau-b correlation coefficient; value in parentheses is n, last value is the probability.

(4) "X" indicates that this parameter was correlated with other parameter with values in same row; e.g., mean phi in May 1979 was negatively correlated with percent sand,  $r = -0.69$  and  $p < 0.0001$ .

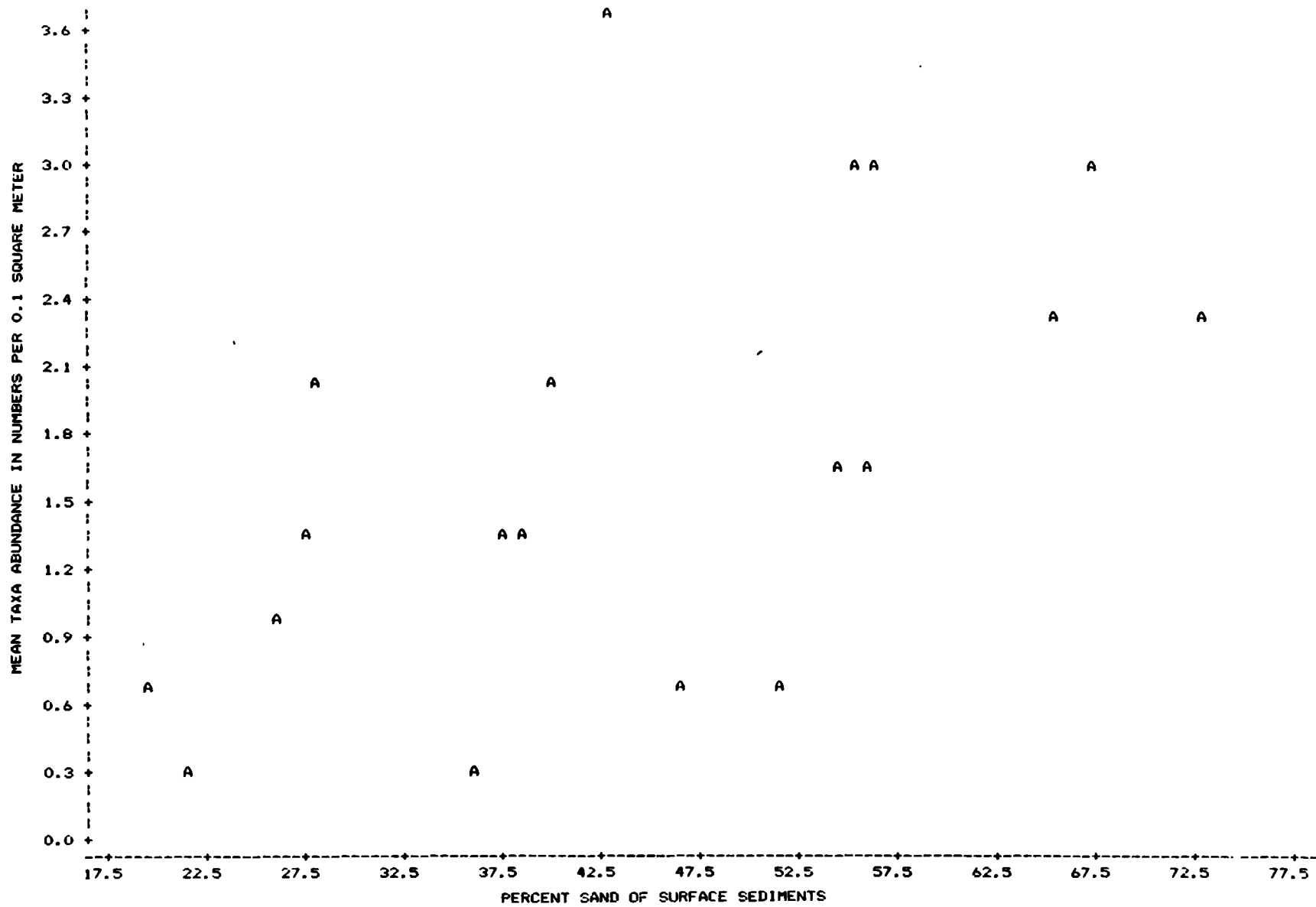

Figure 51. Scatter Plot of Praxilella gracilis versus Percent Sand, May 1979

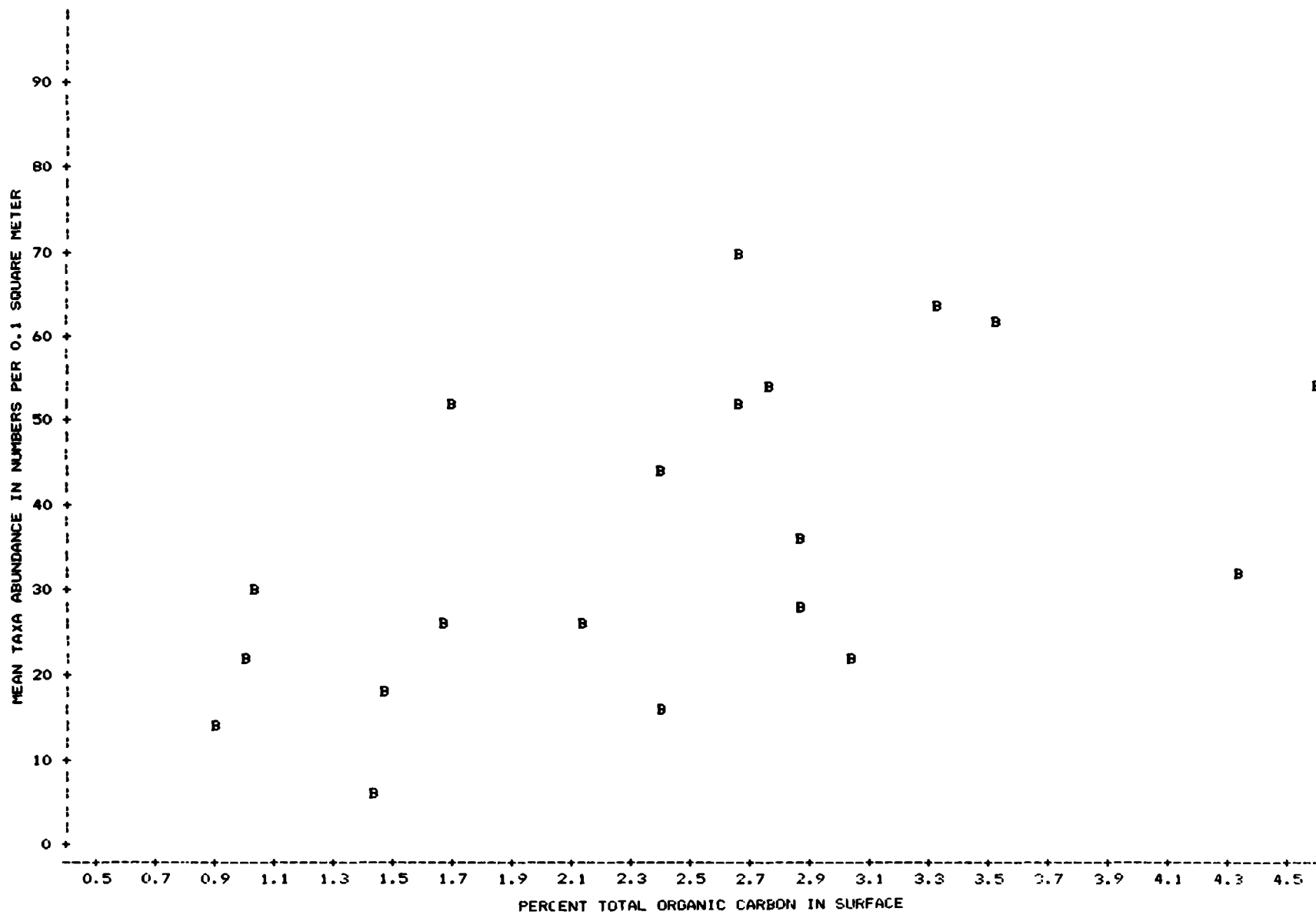

Figure 52. Scatter Plot of Paraonella spinifera versus Percent TOC, May 1979

percent sand. However, since the crustacea data may have included many species having highly variable habitat requirements, correlation between the abiotic parameters and these taxa groups is of limited interpretive value.

The mean abundances of four additional taxa were also positively correlated ( $P < 0.01$ ) with the percent sand of the surface sediments (but not with mean phi). Three of these were the polychaetes Nephtys ferruginea, having a ubiquitous distribution throughout Puget Sound (Harman and Serwold, 1978), Aricidea cf. lopezi, and the family Cossuridae, neither of the latter previously identified near the disposal site (Harman and Serwold, 1978). The correlation coefficients obtained were weak (Table 20). The remaining species which correlated with only the percent sand was the bivalve Axinopsida serricata.

Only one species, the bivalve Nucula tenuis, was correlated to the chemical data. A weak negative correlation was found in relation to percent total organic carbon (Table 20). This species is ubiquitous in the deeper basins of Puget Sound but may prefer the shallower depths in Elliott Bay (R. A. Harman, personal communication).

May 1980 cruise. The mean abundances of seven of the nineteen dominant taxa were correlated with mean phi, percent sand, or both (Table 20). Of these seven, the bivalve Macoma carlottensis and the Amphipoda were correlated to both abiotic parameters, as was also observed with the October data. Of the other five taxa, both Axinopsida serricata and Nephtys ferruginea were also correlated with mean phi and/or the percent sand based on the October data. The abundances of the three other taxa, Capitellidae, Nemertea, and Cumacea, correlated with the percent sand using the May 1980 cruise data only.

Axinopsida serricata was also weakly correlated with the percent total organic carbon, the only organisms to correlate with a chemical parameter during the May 1980 cruise.

A second suite of correlation analyses was performed using the individual station replicates from the October 1979 cruise to allow the inclusion of water depth as a physical parameter and to compare the other results to those obtained using the station means. The results of those tests are summarized in Table 21.



TABLE 21. RESULTS OF THE KENDALL'S CORRELATION ANALYSIS  
 BETWEEN BIOLOGICAL, PHYSICAL, AND CHEMICAL  
 INDIVIDUAL SAMPLE DATA -- OCTOBER 1979 CRUISE (1)

<u>Biological Data</u>		<u>Physical Data</u>		<u>Chemical Data</u>	
<u>Taxa</u> <u>#</u>	<u>Taxa</u>	<u>Water Depth</u>	<u>Mean Phi</u>	<u>% Sand</u>	<u>PTOC</u>
025	<u>Nephtys ferruginea</u>	-0.3894(56) 0.0001	(2) --- (3)	0.3055(46) 0.0037	---
065	Capitellidae	-0.3914(58) 0.0001	---	---	0.2670(47) 0.0085
108	<u>Aricidea</u> cf. <u>lopezi</u>	-0.4043(53) 0.0001	-0.2803(47) 0.0060	0.3721(47) 0.0003	---
151	Amphipoda	---	-0.2760(48) 0.0064	0.3102(48) 0.0022	---
085	Euclymeninae	---	---	---	0.2837 0.0051
185	<u>Macoma carlottensis</u>	-0.3802(58) 0.0001	---	0.2832(48) 0.0046	---

(1) See Appendix E for detailed analysis results.

(2) First value is Kendall's tau-b correlation coefficient; value in parentheses is "n", last value (lower line) is the probability.

(3) "---" indicates that the relationship was not significant (probability >0.01).

Abundances for 6 of the 10 taxa that showed differences in abundances between station groups which were located near the disposal site compared to background stations (determined by the previous Wilcoxon analyses) were correlated ( $P < 0.01$ ) with abiotic data (Table 21). Three polychaete taxa and the bivalve Macoma carlottensis were correlated with water depth; however, the correlation coefficients were low ( $< 0.4100$ ). The polychaete Aricidea cf. lopezi and the Amphipoda were correlated with mean phi size; however, the correlation coefficients were very low ( $< 0.2900$ ). Other results shown in Table 21 also had low correlation coefficients; scattergrams in Appendix E provide a perspective on the wide variability in these data.

Summary of correlation analysis. Overall, the nonparametric correlation analyses using the mean values yielded statistically significant, but rather weak, biological-abiotic correlations for 12, 43, and 37 percent of the dominant taxa for the May 1979, October 1979, and May 1980 cruises, respectively. Although the level of significance ( $P < 0.01$ ) was set conservatively, the low correlation coefficients (ranging from 0.43 to 0.66) and the large scatter apparent in the plots provided an indication of the weak association between the variables. In all cases, neither of the chlorobiphenyl parameters were associated with the abundances of the macrofaunal taxa. In all cases of significant associations between macrofauna taxa and the sediment physical data, the higher taxa abundances were associated with the coarser sediments (greater percent sand and lower mean phi size). None of these data indicate any avoidance of the dredged material by the animals.

#### Overall conclusions of the biological analyses

The results of this study support the conclusion that the animals associated with the deepwater disposal site of Elliott Bay still demonstrated the effects of the experimental dredged material disposal after 4 years. All of the analyses performed, however, agree that, unlike the documented short-term effects of significantly reduced macrofaunal abundances, biomasses, and species richness, the long-term effect was an increase in dominant macrofauna abundances and biomasses on and within the immediate vicinity of the disposal site. Species richness appeared to be comparable on and off the disposal site. Several of the

macrofauna taxa termed "climax" (Harman and Serwold, 1978), hence slow to colonize in the first year after disposal, were found. These include Praxiella gracillis, Asychis similis, Laonice cirrata, and Onuphis irridescens.

The tests for associations between the dominant taxa abundances and the sediment physical/chemical characteristics yielded consistent trends only for increasing abundances with coarser sediments. Of the sediment chemical parameters, the percent total organic carbon was associated with only three of the dominant 21 taxa, while the PCB fractions showed no association with abundance of any taxa. It is, therefore, probable that a combination of several abiotic and biotic factors contributed to the observed macrofauna assemblages with the sediment texture and depth of the site appearing to be of major importance. These factors were also identified by Lie (1974) for many other subtidal habitats of Puget Sound.

The fact that greater abundances and biomasses were characteristic of the disposal site could argue for a generally improved habitat for the normal macrofauna of Elliott Bay. Whether this situation will continue indefinitely depends on the precise factors which lead to the enrichment observed in this study. These may be a combination of preferred sediment texture and increased organic carbon (a possible food source) or may include predator avoidance of the site. In any case, it appears that conditions are stable within the time-frame of normal sedimentary processes in Elliott Bay. The rates of sedimentation in this area are probably slow (on the order of a few centimeters per year or less), but have not been well established (Dexter et al., 1981).

## PART VII: RESULTS OF THE CHEMICAL STUDIES

As was the case with the previous data sets, the detailed tabulations of the raw data obtained from the chemical studies are available on magnetic tape at WES. Only summary tables and figures are presented in this report. Further, by way of explanation, the PCB data are presented and discussed on the basis of concentrations of the isomers having the same degree of chlorination, the N-CB. For example, 3-CB refers to the sum of the trichlorobiphenyl (CB) isomers. The notation t-CB refers to the total chlorobiphenyls, the sum of all isomers, and is thus basically synonymous with PCB.

### Bulk Sediment and Interstitial Water Chemistry

#### Delineation of disposal sediments

In order to increase spatial coverage of the available data, it was assumed that no major changes in distribution of the sediment chemical parameters occurred among the four cruises (justification for this assumption is presented below). On this basis, the data were combined in much of the discussion below.

Since it was noted in the original disposal monitoring study that both the total concentrations and type of PCBs associated with the dredged material were different than observed in the background sediments at the disposal site, the PCB characteristics were expected to provide one of the best discriminators of the present spatial distribution of the dredged material.

However, both the horizontal and vertical distributions of PCB residues in the sediments exhibited a high degree of spatial heterogeneity. For example, Figure 53 shows vertical profiles of the t-CB concentrations in three cores at each of two stations, one near the center of the disposal grid (station 104) and one from the area east of the disposal area (station 122) in February 1979.

The variability made it difficult to establish trends or to accurately delineate areas of similar and/or different PCB levels. However,

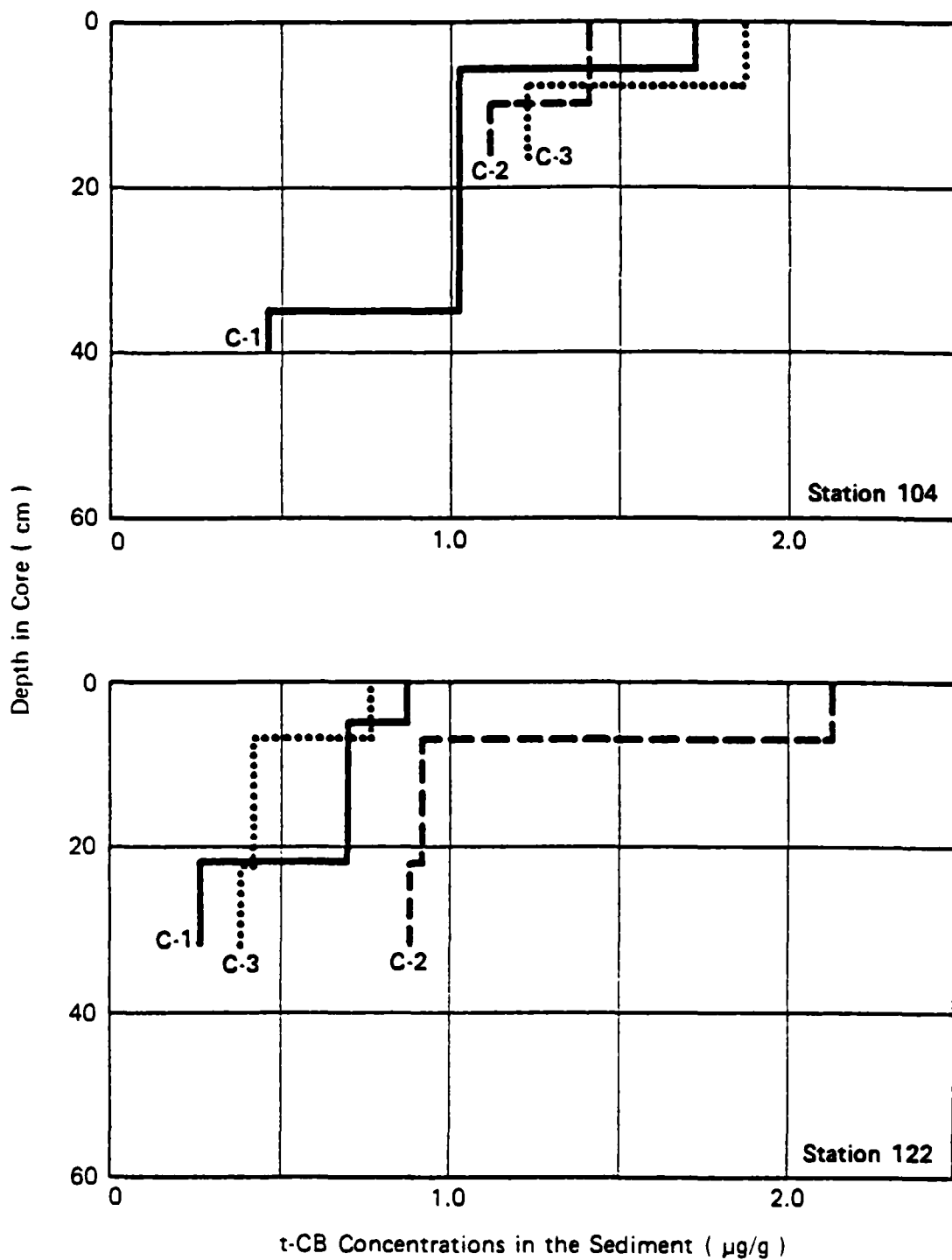

Figure 53. Contour Plot of the Concentration of Total-CB Observed in the Surface Sediment Horizon

the general characteristics of the PCB distribution are presented as a contour plot of the t-CB concentrations in the surface sediments (Figure 54). The highest observed t-CB concentrations were used for those stations with replicate samples, to present a "worst case" scenario. In addition, the contour lines were based on subjective extrapolation and interpolation, taking into account primarily the PCB data and, in part, the bathymetry of the area. As a result of these limitations, only general trends should be inferred from the contour plots.

In agreement with the distribution noted in past studies (Pavlou et al., 1978; Pavlou and Dexter, 1979), these data indicated an overall gradient of decreasing PCB levels from east to west in the sediments surrounding the original disposal grid, with values ranging from 2.14 ug t-CB/g dry sediment (ppm) at one replicate from station 122 to 0.29 ppm at station 126. While previous work has documented elevated levels near the mouth of the West Waterway of the Duwamish River with a gradient of decreasing PCB values toward the north, a similar north-south gradient was only marginally indicated by the present data. This may simply reflect the limited sampling south of the disposal area performed during this study.

Elevated t-CB concentrations were clearly associated with the surface sediments at the disposal site, with the highest levels observed in the vicinity of the mound distinguishable in the bathymetry. However, the surface t-CB concentrations were spatially variable within the disposal area ranging from a low of 0.46 ppm (station 103, February 1979) to a high of 7.73 ppm (station 103, replicate 2, October 1979) apparently reflecting primarily the differences in the t-CB concentrations of various portions of the dredged material rather than any dependence on the depth of the deposit or location within the disposal area.

It was established in the earlier disposal monitoring study (Pavlou et al., 1978) that the dredged material was relatively enriched in lower chlorinated chlorobiphenyls compared to the background sediments at the site. Therefore, the concentrations of trichlorobiphenyl (3-CB) residues in the surface sediments were also used to generate a contour plot (Figure 55). Note that the same cautions regarding the

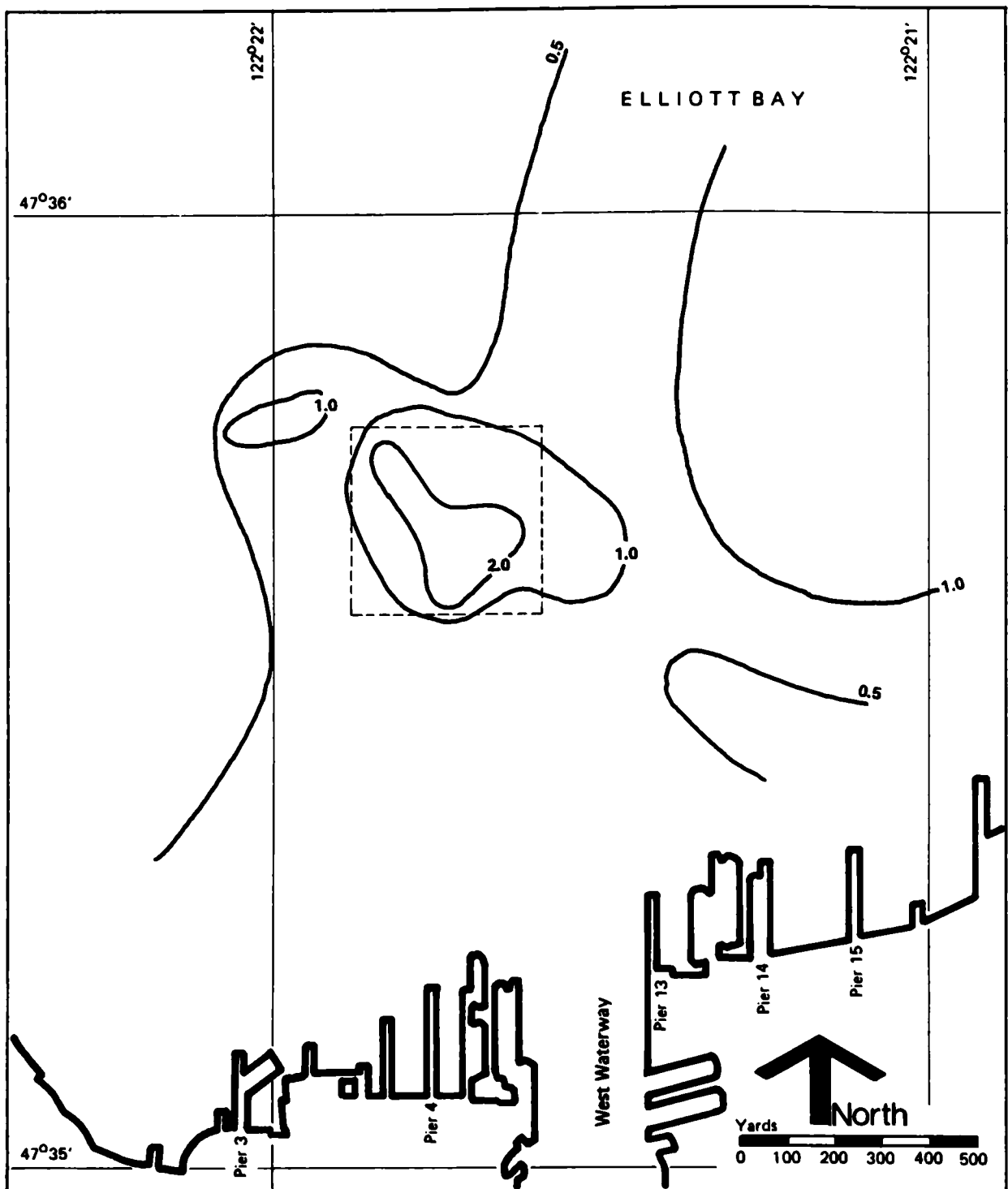

Figure 54. Concentration Contours of the Approximate Distribution of t-CB in the Surface Sediments. Concentrations in units of ug/g

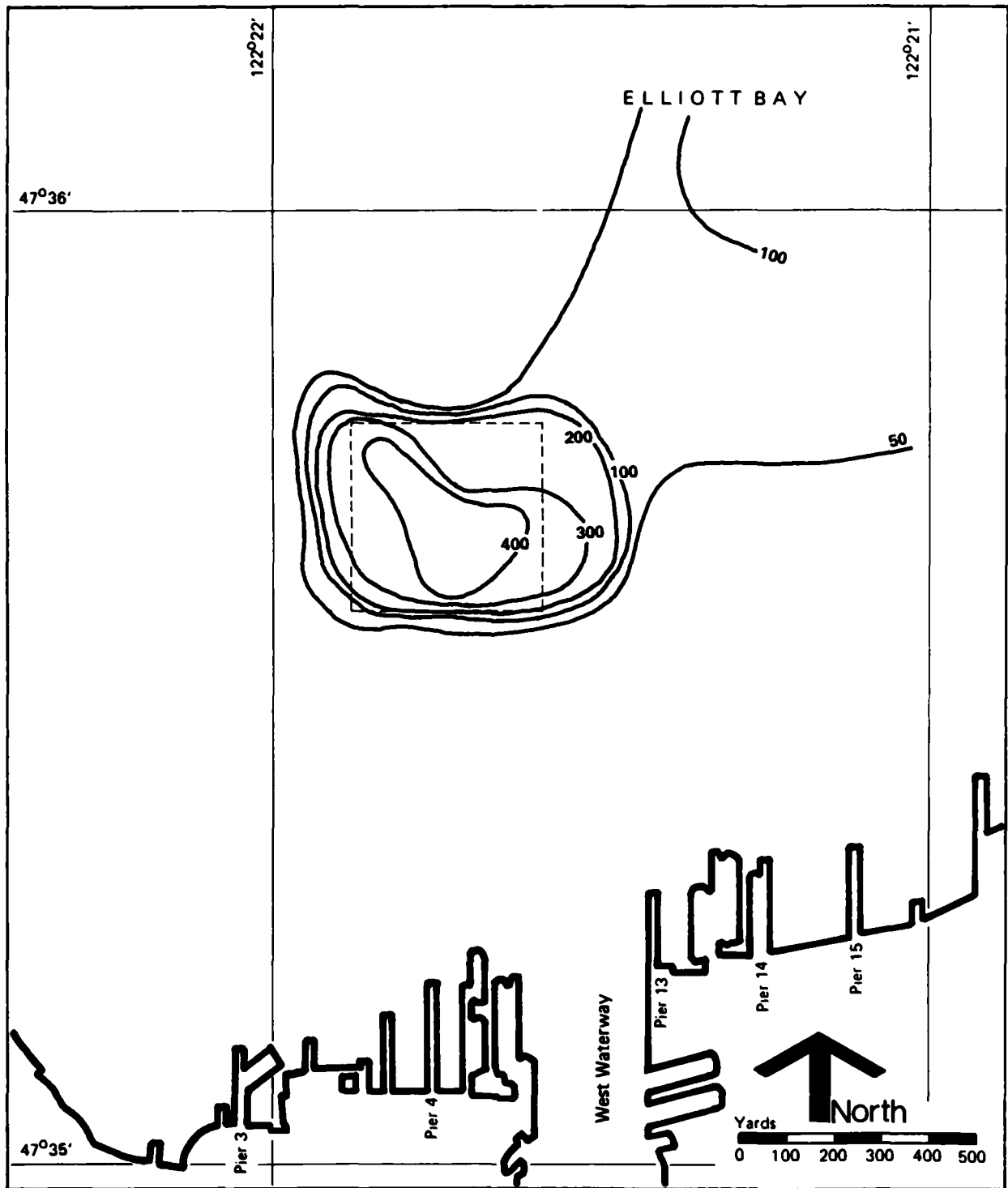

Figure 55. Concentration Contours of the Approximate Distribution of 3-CB in the Surface Sediments, Cruises 1, 2, 3, and 4. Concentrations in units of ng/g



interpretational utility discussed above for the t-CB contour map apply as well to Figure 55. Even with these restrictions, the much more limited areal extent of the high 3-CB levels compared to the t-CB residues is apparent and corresponds well with location of the disposal mound observed in the bathymetric surveys.

One of the major reasons for collecting reconnaissance cruise (February 1979) PCB data was to use the characteristic N-CB concentrations to discriminate between dredged material and normal or background sediments, thus delineating the spatial extent of the dredged material deposit. To this end, all of the N-CB data from the reconnaissance cruise were subjected to cluster analysis. The resulting dendrogram (Figure 56) indicated four major and one minor grouping (at Dissimilarity Coefficient = 1.5). Of these groupings, the majority of the disposal site samples fell within group one, which included the samples high in both t-CB and 3-CB. At the same time, the groupings were not entirely consistent with what was expected from the results of the original study: that similar, high PCB sediments would be found at all stations within the original grid, but only within short distances of the grid in the background sediments.

During the reconnaissance 1979 cruise, high 3-CB and t-CB concentrations characteristics of group one stations were not observed at any depth at stations 109, 111, or 112 (northwestern and southern corner stations), while at least one horizon from stations 113, 114, 115, 116, 117, 118, 122, and 130 fell within group one. In addition, central grid stations 101 and 103 had intermediate and surface horizons, respectively, which were not included in group one.

As a result of these apparent discrepancies, it was recognized that a clear delineation of the disposal material was not possible based on the PCB data alone. However, since the sediment-type descriptions discussed earlier appeared to provide a fairly coherent delineation of the dredged material, a histogram was constructed (Figure 57) to examine the 3-CB concentrations associated with each sediment type. Two major groupings of the samples resulted:

- A. High 3-CB (and high t-CB) levels principally associated with the SS and SI sediment types, and
- B. Sediment types SA, MS, SC, and CL almost exclusively associated with low 3-CB (and generally lower t-CB) concentrations.

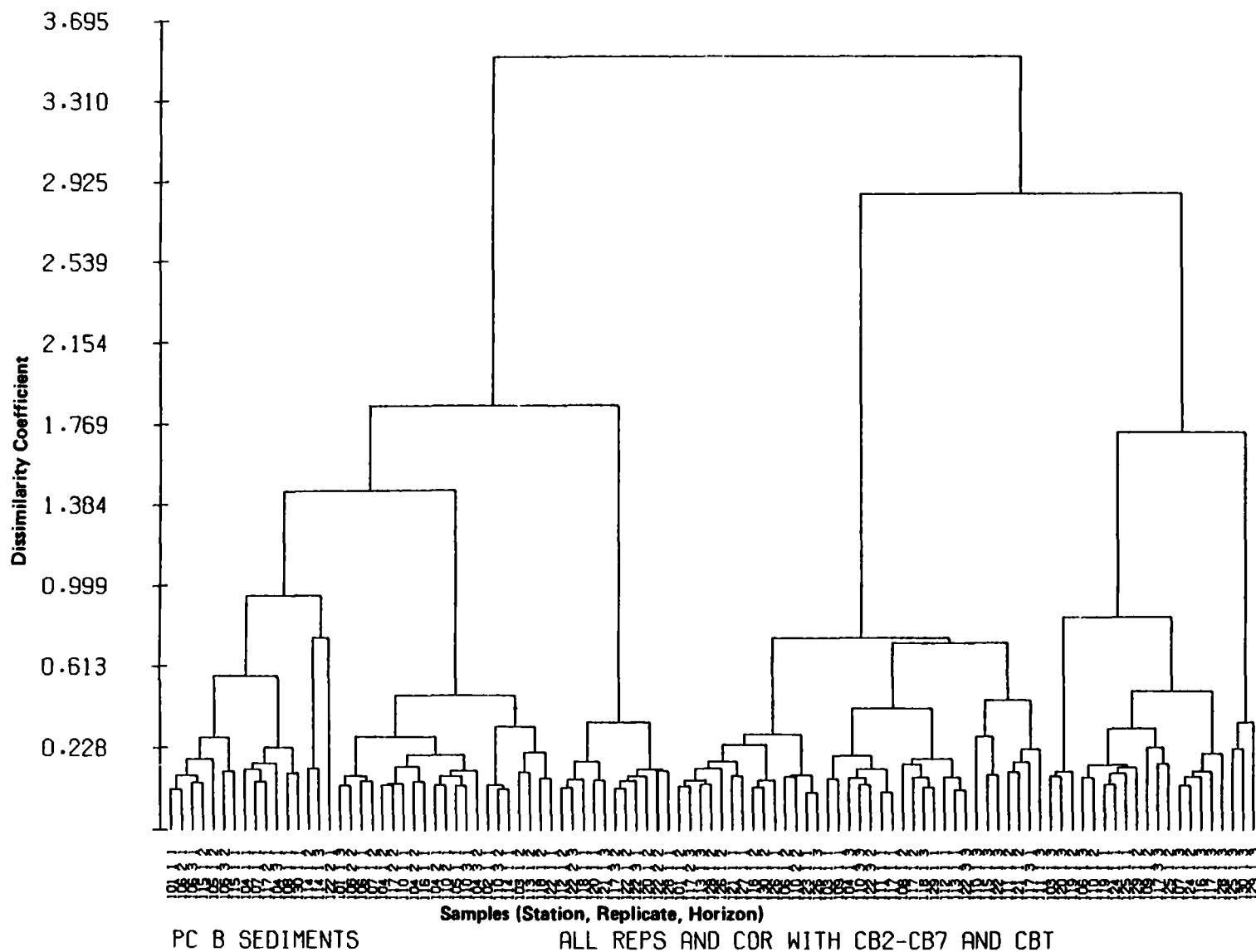

Figure 56. Dendrogram of Sediment Clustering of February 1979 PCB Data

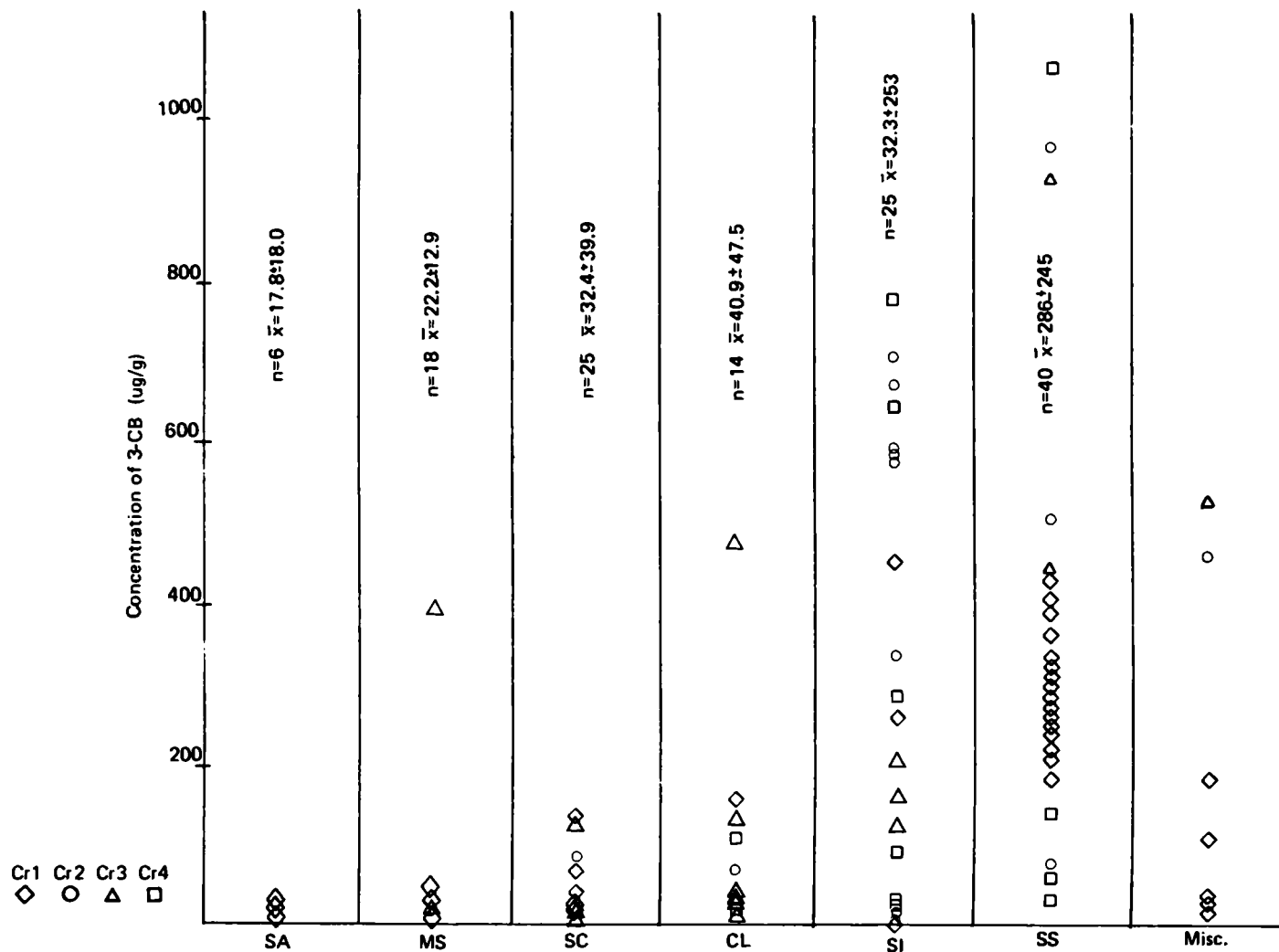

Figure 57. Histogram Showing Relationship of 3-CB Concentration to Sediment Type. Sediment types are defined in Table 1. Mean 3-CB concentrations and numbers of samples (n) are also included for each sediment type. Data are from the reconnaissance cruise  $\diamond$ ; May 1979,  $\circ$ ; October 1979,  $\triangle$ ; and May 1980,  $\square$

The PCB data thus support the conclusion of the sediment texture analyses that the dredged material is predominantly characterized by SS and SI type sediments and thus also support the delineation of the dredged material deposit presented in Figure 37. There were a few samples which were not clearly discriminated by these parameters, i.e., high 3-CB concentrations associated with type MS or CL sediments, and type SS and/or SI sediments with PCBs not characteristic of the dredged material. However, these samples were limited and generally consisted of surface or interbedded horizons within cores, which otherwise were either clearly dredged material or clearly not dredged material.

This delineation (Figures 57 and 37) was used to compare the sediment chemistry for the dredged material with that of the "background" sediments and over time. The general bulk chemical characteristics of these two sediment groups are compared in Table 22, which presents mean values of all cruises for the surface sediments (approximately upper 5 cm) for t-CB, 3-CB, TOC, and oil and grease (O&G). While the mean concentrations of all of these parameters were higher in the dredged material than in surrounding sediments, the variability was so great that only the differences in the PCB concentrations were statistically significant (students t-test,  $\alpha = 0.01$ ). The spatial and temporal characteristics of each of these parameters are discussed in detail below.

TABLE 22

COMPARISONS OF OVERALL MEAN CONCENTRATIONS OF  
t-CB, 3-CB, TOC, AND O&G OF SURFACE (0-6 cm)  
DREDGED MATERIAL SEDIMENTS TO THE  
CORRESPONDING CONCENTRATIONS IN THE  
SURFICIAL NON-DREDGED MATERIAL SEDIMENTS

	Concentrations			
	t-CB ng/g	3-CB ng/g	TOC %	O&G mg/g
Dredged Material	2069+1217 (30)	344+197 (30)	2.97+1.34 (27)	2.41+0.98 (12)
Non-Dredged Material	607+434 (33)	37+40 (33)	2.88+1.25 (23)	1.46+0.74 (17)

### Distribution of PCBs in the bulk sediments

As discussed above, the general spatial distribution in the background sediments showed higher t-CB concentrations east and, to some extent, south of the disposal site. If data from the samples of background sediments observed below the dredged material in deep cores at the disposal site are included with that from the surficial sediments from the other sites, a coherent distribution is apparent (Figure 58). This distribution can be explained as responding to three independent functions: 1) deposition of higher PCBs associated with finer grained sediments to the east of the disposal site; 2) higher PCB levels associated with deposition of sediments from the Duwamish River, and 3) one or two small areas of anomalously high PCB concentrations which may reflect past incidences of dumping and/or spills, one near the center of the disposal site and one area northwest of the site. Similar samples with anomalously high PCB levels were noted prior to disposal in Pavlou et al. (1978). Total PCB levels in the eastern sediments and in the anomalies approached or exceeded the concentrations observed in many of the dredged material sediments.

Within the dredged material deposit, PCB concentrations varied both horizontally and vertically (Figure 59), apparently reflecting the unordered distribution of sediments which resulted from the disposal operation. Comparisons of the mean t-CB concentrations for each core, and for the five horizons in the cores for each cruise, are summarized in Table 23. For these comparisons, the means do not include those horizons which penetrated to the background sediments. These mean concentrations, both for cores and for horizons, exhibited a limited range and generally showed similar variability. No statistical differences were noted between any of the means. These data indicated that the PCB concentrations were randomly variable within the dredged material deposit.

### Temporal trends in PCB concentrations

One of the major purposes of the PCB data collection was to determine the long-term trends in the levels of PCBs associated with the dredged material sediments. Comparisons among the recent data and that

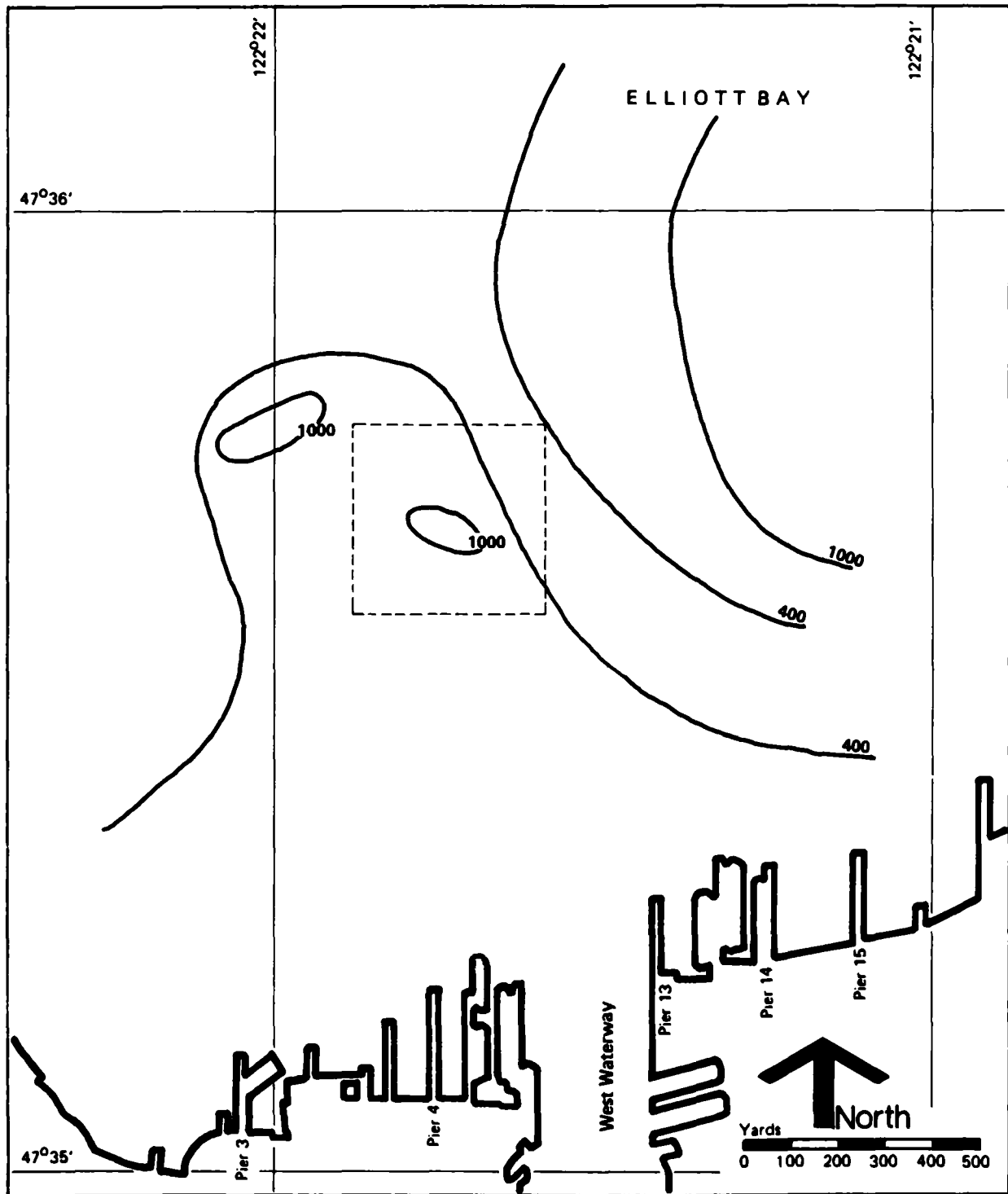

Figure 58. Contours of the Approximate Concentrations of t-CB in Background Sediments at the Disposal Site together with Surface Sediments at Non-Dredged Material Sites, Cruises 1, 2, 3, and 4. Concentrations are in units of nanograms

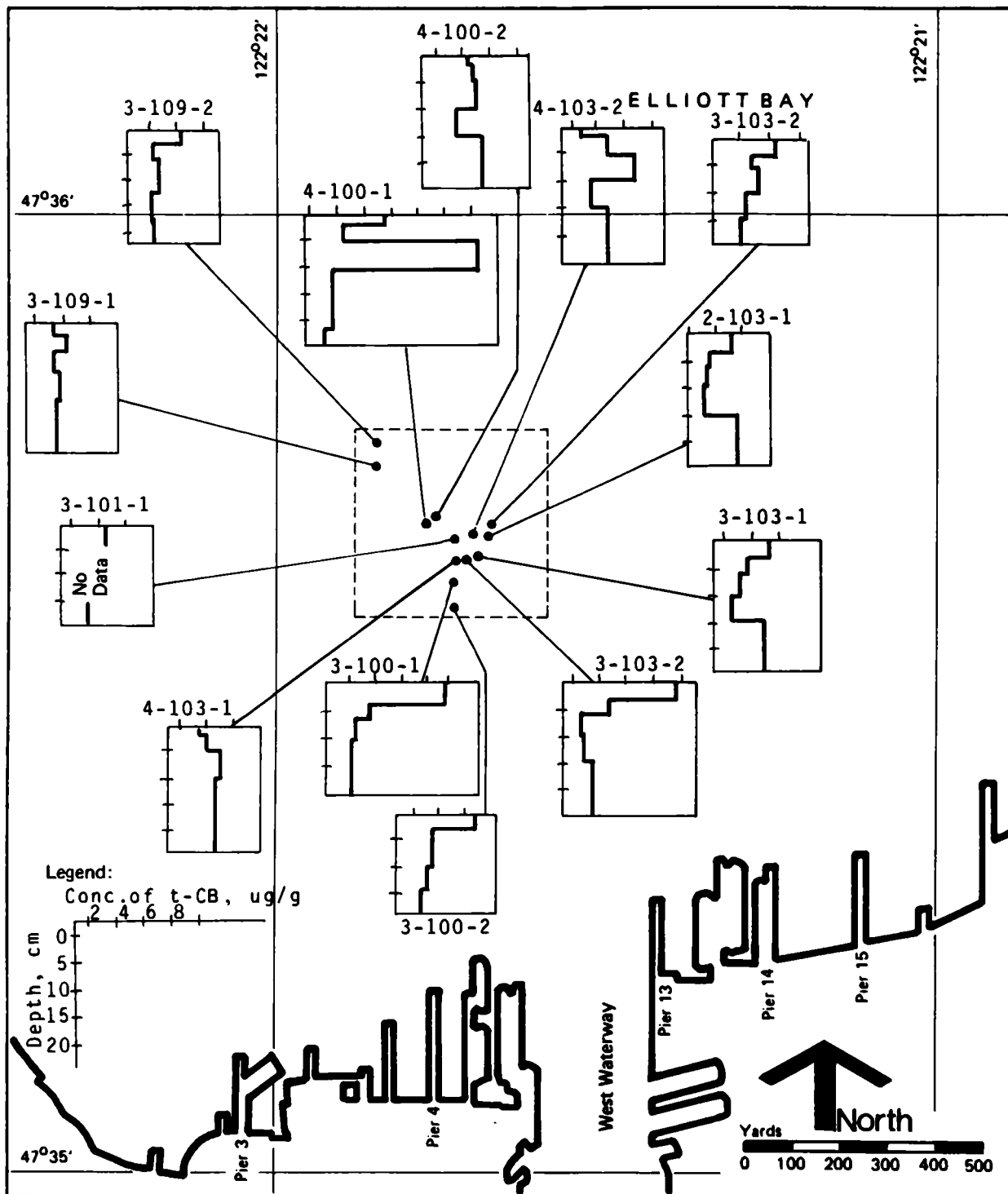

Figure 59. Depth Profiles of the t-CB Concentrations in the Dredged Material Cores. The core profiles are named as cruise-station-replicate number, and are keyed to the actual station locations

TABLE 23. COMPARISONS AMONG CRUISES OF THE MEANS AND STANDARD DEVIATIONS OF THE t-CB CONCENTRATIONS IN THE DREDGED MATERIAL SEDIMENTS.

A. AMONG CORES

Station-Core	Cruise 2 May 1979		Cruise 3 October 1979						Cruise 4 May 1980			
	103-1	103-2	100-1	100-2	103-1	103-2	109-1	109-2	100-1	100-2	103-1	103-2
	2129 <sup>a</sup>	2976	4199	2020	1932	2639	1551	994	4932	2447	2058	2615
	+1150	+1049		+1788	+1148	+2947	+401	+765	+4668	+726	+732	+1491
	(5)	(5)	(2)	(4)	(5)	(5)	(5)	(4)	(5)	(5)	(5)	(5)

B. AMONG HORIZONS

Horizon	Cruise 2 May 1979	Cruise 3 October 1979	Cruise 4 May 1980
H-1 (0-3 cm)	3904(2) <sup>a</sup>	4355+2633(6)	2541+2358(4)
H-2 (3-6 cm)	2049(2)	1547+831(6)	2360+604(4)
H-3 (6-10 cm)	2160(2)	948+200(5)	5730+4729(4)
H-4 (10-15 cm)	1777(2)	975+472(5)	1800+519(4)
H-5 (15-25 cm)	2872(2)	1529+414(3)	2633+690(4)

<sup>a</sup> Data presented are the mean t-CB concentrations, ng/g, + the standard deviation. Numbers in parentheses indicate the number of cores (Part A) or horizons (Part B) constituting the means.



obtained during the original study (Pavlou et al., 1978) are presented in Table 24. These comparisons are based on the average concentrations observed in the upper 10 cm of the dredged material from both studies to provide comparable data. The data from the original study are limited to those from cores taken at the central disposal site stations only, since some of the peripheral stations appeared to have penetrated to background sediments in the upper 10 cm. The agreement among these mean values was good and indicated that no major changes in the overall t-CB concentrations had occurred at the site since disposal.

TABLE 24. COMPARISONS AMONG CRUISES OF THE MEAN CONCENTRATIONS OF t-CB IN THE UPPER 10 CM OF THE DREDGED MATERIAL SEDIMENTS

<u>Sampling Date</u>	<u>PCB Concentrations, ng/g</u>
March 1976 <sup>a</sup>	2195 <sub>+</sub> 1161(8) <sup>c</sup>
April 1976 <sup>a</sup>	2128 <sub>+</sub> 927(8)
June 1976 <sup>a</sup>	2187 <sub>+</sub> 1085(8)
Sept. 1976 <sup>a</sup>	2938 <sub>+</sub> 1298(8)
Dec. 1976 <sup>a</sup>	3442 <sub>+</sub> 2117(8)
May 1979 <sup>b</sup>	2704(2)
Oct. 1979 <sup>b</sup>	2205 <sub>+</sub> 898(7)
May 1980 <sup>b</sup>	3544 <sub>+</sub> 2384(4)

a Data from Pavlou et al. (1978).

b Data from this study.

c Mean concentration with one standard deviation. Number in parentheses indicates number of samples in the mean.

---

At the same time, it was recognized that PCBs probably have very low mobility in bedded sediments and, hence, 10 cm fractions may be too large to detect changes occurring near the sediment-water interface. For this reason, the cores from the recent cruises (May 1979, October 1979, and May 1980) were sectioned at much smaller intervals. The distribution of the concentrations of t-CBs in the dredged material cores was presented in Figure 58, and is summarized in Table 25 as the

TABLE 25. COMPARISONS AMONG CRUISES OF THE MEAN t-CB AND 3-CB CONCENTRATIONS AND THE FRACTION OF 3-CB TO THE TOTAL PCB CONCENTRATION ( $F_3$ ) FOR THE UPPER HORIZONS OF DREDGED MATERIAL AND NON-DREDGED MATERIAL SEDIMENTS

		Dredged Material				Non-Dredged Material			
		$n^a$	t-CB	3-CB	$F_3$	n	t-CB	3-CB	$F_3$
Cruise 2 May 1979	H-1	2	3904 <sup>b</sup>	538 <sup>b</sup>	0.122	7	696+472	28+16	0.064+0.046
	H-2	2	2049	405	0.196	7	571+326	22+15	0.052+0.040
	H-3	2	2160	474	0.229	5	477+578	7+7	0.030+0.021
Cruise 3 Oct 1979	H-1	7	4197+2475	537+265	0.154+0.046	4	278+150	13+9	0.045+0.008
	H-2	5	1809+590	250+85	0.148+0.063	4	204+96	10+9	0.043+0.019
	H-3	5	1057+244	229+58	0.228+0.051	4	276+181	35+60	0.080+0.102
Cruise 4 May 1980	H-1	4	2541+2358	398+299	0.181+0.060	6	620+365	36+22	0.075+0.050
	H-2	4	2360+604	515+175	0.221+0.055	6	1581+1243	64+52	0.075+0.068
	H-3	4	5730+4739	871+440	0.177+0.041	(4) 6	823+501 666+303	87+51 46+17	0.107+0.056 0.081+0.034

a n refers to number of samples in the mean

b Mean concentrations, ng/g, with one standard deviation (n greater than 2)

mean concentration per horizon per cruise for the upper three horizons. The t-CB concentrations in the surface horizons of the dredged material did not show any significant decrease in comparison to the underlying sediments, nor were there any significant differences among cruises.

In addition to the t-CB levels, it was considered likely that the lower chlorinated PCBs, being less strongly sorbed (Dexter, 1976), would show preferential losses from the surface sediments. Therefore, the mean concentrations of 3-CB per horizon per cruise are also summarized in Table 25, together with the means of the ratios between the 3-CB and t-CB concentrations ( $F_3$ ). (The latter value provided a measure of the PCB type, with less chlorinated PCB mixtures showing higher  $F_3$  values.) As was the case with the t-CB concentrations, the 3-CB concentrations did not indicate a significant decrease with time among cruises, nor in comparison among horizons. By and large, the 3-CB concentrations reflected the differences of the t-CB concentrations among the samples.

If significant losses of PCBs were occurring, the greater loss rate of the 3-CB compared to the higher chlorinated isomers would have been expected to produce lower  $F_3$  values in the surface sediments compared to those deeper in the core and a decrease in the  $F_3$  values over time. Data from the two May cruises (Table 25) did exhibit lower  $F_3$  values in the surface horizons, while the measured  $F_3$  values of the surface sediments actually increased slightly during the study period. Neither of the changes were significant but, rather, appeared to reflect the variability in the dredged sediments. Overall, no characteristic which was examined was capable of distinguishing the PCBs in the surface sediments from those of any other horizon. Together with the fact that no overall decrease in the PCB concentrations was observed strongly argues for the long-term chemical stability of the PCBs at the disposal site.

In comparison to the disposal site data, cores from the non-dredged material stations also showed considerable variability with depth in the

core (Figure 60). The background sediments generally exhibited higher t-CB concentrations in the upper horizons compared to those deeper in the sediments (>10 cm deep). Within the upper three horizons, however, no clear trends were evident. Most cores from Cruises 2 and 3 had higher t-CB concentrations in the surface horizon compared to the second horizon, while all of the cores from Cruise 4 had lower t-CB levels at the surface. Mean values for t-CB, 3-CB, and  $F_3$  per horizon for these upper three horizons of each cruise are also shown in Table 25, and indicate the relatively small range of these parameters with depth in the cores. None of the differences in the means among horizons were significant. Differences among cruises appeared to reflect station locations of the samples, with Cruise 3 (stations 145 and 148) being representative of northerly, lower PCB stations, while Cruises 2 and 4 sampled areas to the east and south of the disposal site.

The Cruise 4, horizon 2, data are presented in Table 25 both including (n=6) and excluding (n=4) the high PCB concentrations observed in this horizon from both cores from Station 157 (Figure 60). The PCBs from this horizon were enriched in highly chlorinated PCBs compared to the distribution of biphenyl components normally observed in the background sediments and were apparently another example of anomalous PCB concentrations. The sources of these anomalies are unknown but may reflect minor spills or other direct discharges. Exclusion of these values from the means makes the Cruise 4, horizon 2, values similar to the other horizons from that cruise.

#### Distribution of total organic carbon (TOC)

The sediments in the study area are known to contain variable quantities of both wood chips and coal fragments, the former from log-handling activities in the area and the later from natural coal deposits in the drainage basin of the Duwamish River. As a result, the technique employed in the TOC analysis ( $H_2O_2$  digestion) was selected over more rigorous techniques, e.g., high temperature combustion, to obtain data on the less resistant organic matter fraction considered a more likely contributor to the detrital food web. However, visual

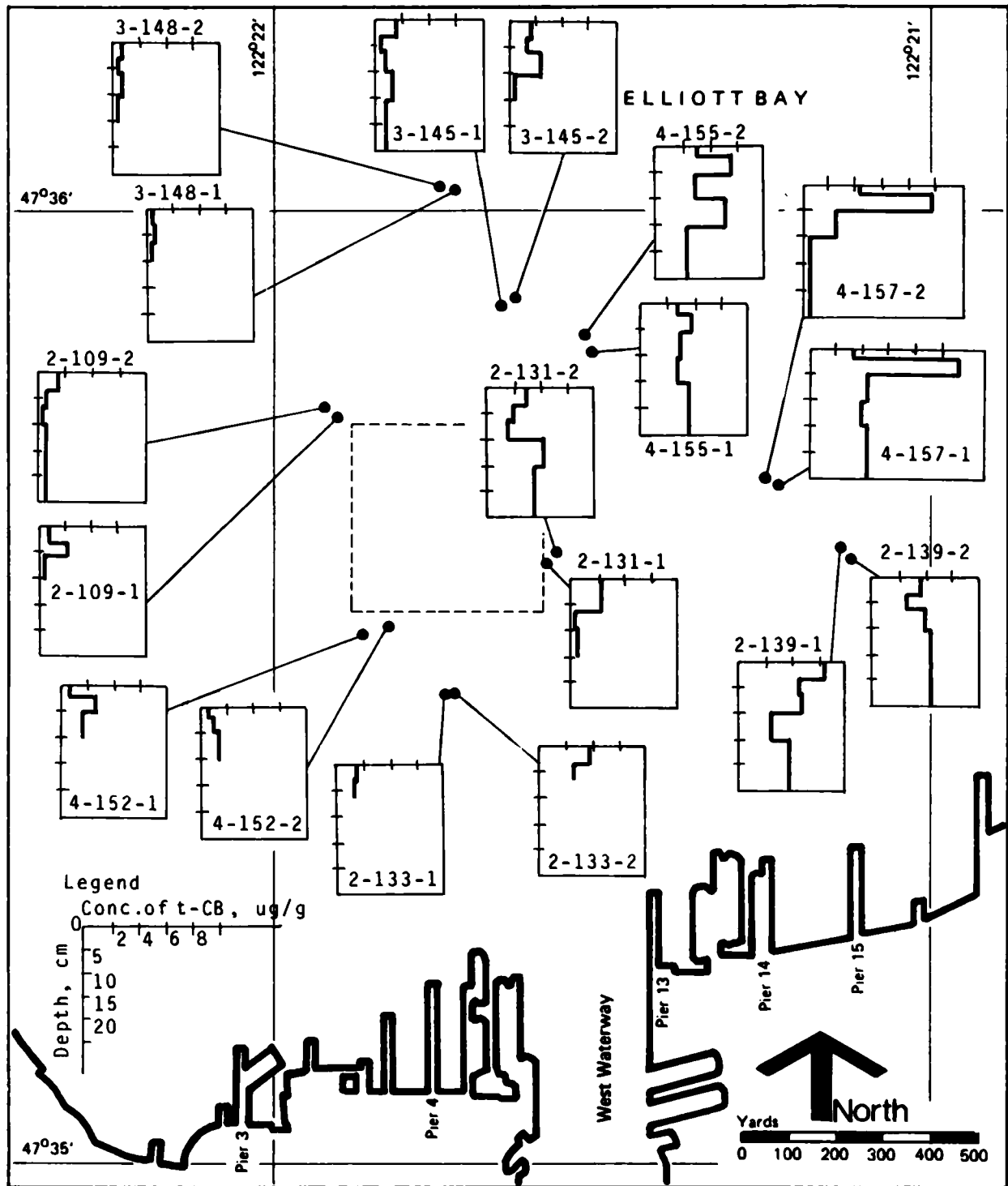

Figure 60. Depth Profiles of the t-CB Concentrations in the Non-Dredged Material Cores

evidence of the partial decomposition of larger wood chips present in some of the samples indicated that the technique was not wholly selective. This may have contributed some additional variability to the TOC data and limited the establishment of clear trends and relationships among the data.

An overview of the distribution of the percent TOC observed in the surface sediments is presented in Figure 61, using station mean values. The TOC levels in the dredged material sediments were spatially variable within the disposal site, ranging from approximately 1 percent to 6 percent. This area is depicted in Figure 61 as the overall mean of all dredged material surface samples from Cruises 2, 3, and 4.

Away from the disposal site, the TOC levels were also quite variable with an apparent trend toward higher percent TOC in the finer sediments east of the disposal site and lower values both south and north of the site.

As shown in the summary Table 26, while the mean TOC percentages of the dredged material were generally higher than observed in the background sediments, these differences were not significant with many samples from both areas showing similar TOC levels (e.g., see Figure 61). Similarly, no significant differences in TOC percentages were observed for any horizon among or within the cruises.

TABLE 26. MEAN CONCENTRATIONS OF TOC PER HORIZON PER CRUISE FOR DREDGED MATERIAL AND NON-DREDGED MATERIAL SEDIMENTS

	<u>Horizon</u>	<u>Dredged Material</u>		<u>Non-Dredged Material</u>	
		<u>n</u>	<u>TOC, %</u>	<u>n</u>	<u>TOC %</u>
Cruise 2 May 1979	1 (0-5 cm)	25	2.66+1.36	17	2.07+1.25
	2 (5-10 cm)	22	2.48+1.41	15	1.72+0.76
	3 (10-25 cm)	10	3.17+1.51	4	1.09+0.48
Cruise 3 Oct 1979	1 (0-5 cm)	32	2.40+1.03	16	1.63+0.98
	2 (5-10 cm)	28	2.76+1.26	12	1.45+0.66
	3 (10-25 cm)	9	3.19+1.58	8	1.11+0.53
Cruise 4 May 1980	1 (0-5 cm)	33	3.25+1.56	15	2.52+0.93
	2 (5-10 cm)	25	3.19+1.60	12	1.48+0.56
	3 (10-25 cm)	9	3.03+0.55	9	2.05+1.06

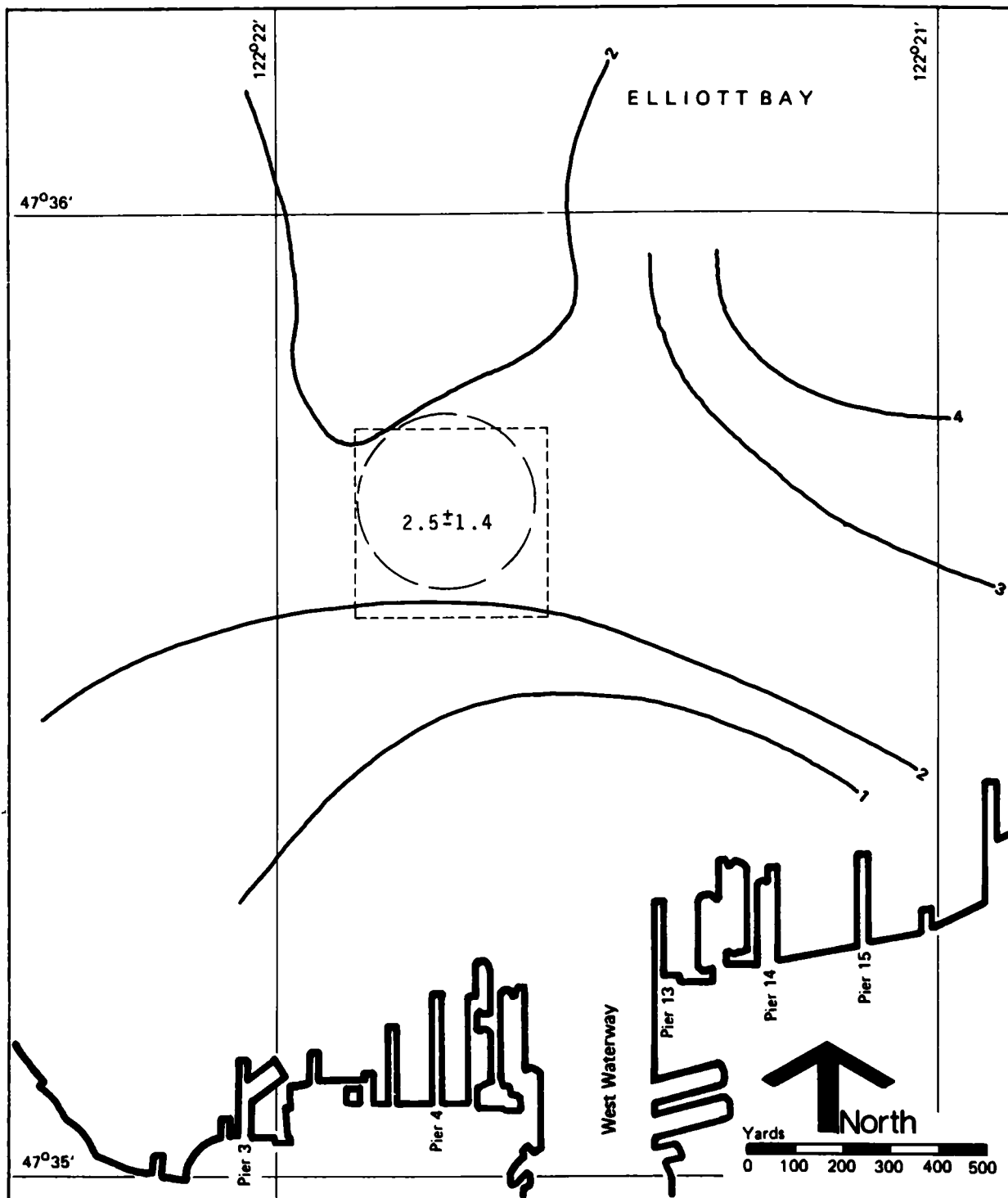

Figure 61. Contours of the Approximate Percent TOC of the Surface Sediments, Cruises 2, 3, and 4

Distributions of oil and grease (O&G)

The concentrations of O&G, i.e., hexane-extractable substances, were measured in aliquots of samples taken for PCB analysis on Cruises 2, 3, and 4 and thus provide a smaller data set than obtained for TOC. The general distribution of O&G concentrations is depicted in Figure 62 as a summary plot of the concentrations observed in the surface sediments, combining the data from all three cruises. The data are insufficient to establish clear spatial trends, but indicate that higher O&G concentrations tend to be associated with the dredged material and with lower concentrations south of the disposal site. There was considerable overlap among the O&G concentrations associated with the dredged material and those observed in the background sediments.

Mean concentrations of O&G observed per sediment horizon and per cruise are summarized in Table 27. Comparisons between the mean values

TABLE 27. MEAN CONCENTRATIONS OF O&G PER HORIZON PER CRUISE FOR DREDGED MATERIAL AND NON-DREDGED MATERIAL SEDIMENTS

	<u>Horizon</u>	<u>Dredged Material</u>		<u>Non-Dredged Material</u>	
		<u>n</u>	<u>O&amp;G, mg/g</u>	<u>n</u>	<u>O&amp;G, mg/g</u>
Cruise 2 May 1979	1 (0-3 cm)	2	2.82	8	1.49+0.86
	2 (3-6 cm)	2	2.50	6	1.20+0.64
	3 (6-10 cm)	1	2.62	5	1.14+0.33
	4 (10-15 cm)	2	2.77	5	0.97+0.46
	5 (15-25 cm)	2	2.91	5	1.08+0.23
Cruise 3 Oct 1979	1 (0-3 cm)	5	1.51+0.66	4	2.03+0.78
	2 (3-6 cm)	6	2.17+0.86	4	1.66+1.22
	3 (6-10 cm)	5	2.67+1.55	5	0.94+0.31
	4 (10-15 cm)	5	2.06+0.60	5	0.79+0.25
	5 (15-25 cm)	3	2.94+1.22	7	1.14+0.57
Cruise 4 May 1980	1 (0-2 cm)	4	3.32+1.66	5	0.95+0.94
	2 (2-5 cm)	4	2.95+0.95	5	1.55+0.77
	3 (5-10 cm)	4	3.35+1.24	6	1.05+0.56
	4 (10-15 cm)	4	2.96+1.00	5	1.18+0.43
	5 (15-20 cm)	4	3.10+0.43	4	1.21+0.20

for the dredged material and for those of the background sediments yielded generally higher levels associated with the former sediments. However, the variability made these differences not significant. Similarly, for



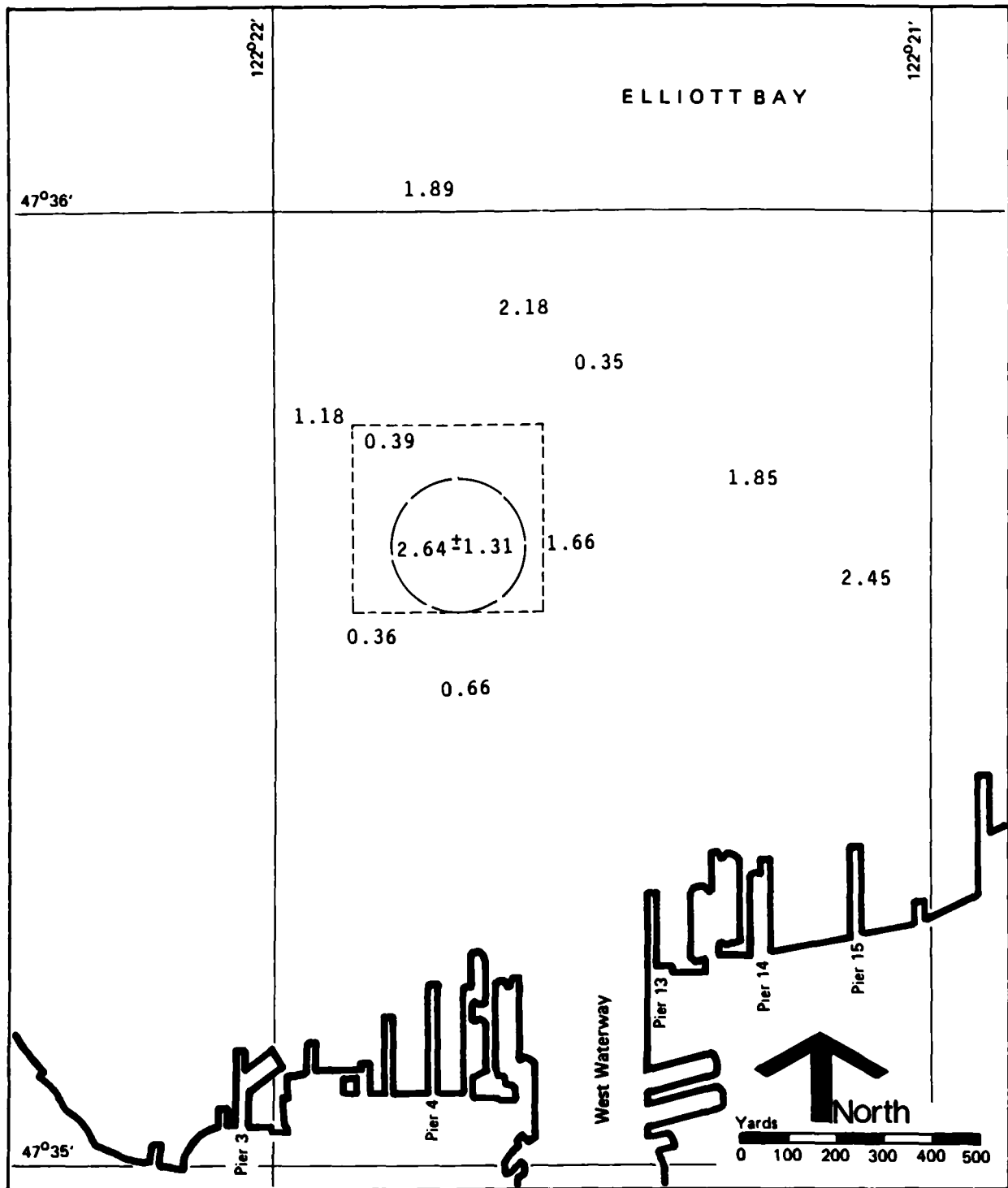

Figure 62. Spatial Distribution of O&G in the Surface Sediments. O&G values represent station averages for non-dredged material stations and as mean of disposal site sediments, units: mg O&G/g dry sediment

both dredged material and background sediments, no clear trends were apparent for the distribution of O&G within the cores, or among the cruises. Finally, comparison of the mean values for the dredged material obtained in Pavlou et al. (1978) with those observed recently (Table 28) indicated a possible increase in the O&G concentrations with time. However, the differences were small, with considerable variability, and the number of samples was limited. Hence, no temporal trend can be considered as clearly established.

TABLE 28. COMPARISONS OF THE MEAN OIL AND GREASE CONCENTRATIONS IN THE UPPER 10 CM OF THE DREDGED MATERIAL DEPOSITS AMONG CRUISES

<u>Date</u>	<u>n</u>	<u>Concentration of Oil and Grease, mg/g</u>
March 76	8	1.26+0.35
April 76	8	1.48+0.75
June 76	8	1.54+0.35
September 76	8	1.59+0.31
December 76	7	1.59+0.54
May 79	2	2.52
Oct. 79	6	2.10+0.76
May 80	4	3.21+1.02

#### Relationship of sediment physical and chemical parameters

Relationships among the physical and chemical parameters were examined for possible explanations of at least some of the spatial variability. This analysis was predicated on hypotheses developed by Dexter and Pavlou (1978): 1) because of their greater surface area to mass ratios, finer sediments should accumulate greater quantities of both natural and anthropogenic organic compounds, and 2) natural organic matter should provide a preferential accumulation site for other lipophilic organic compounds, i.e., O&G and PCBs, compared to inorganic particles. The relationships dictated by these principles were tested by correlating the physical and chemical parameters obtained in this study, yielding a series of scatter plots (Figures 63-67).

Recognizing the different sources for the dredged material and the non-dredged material sediments, these correlations were performed

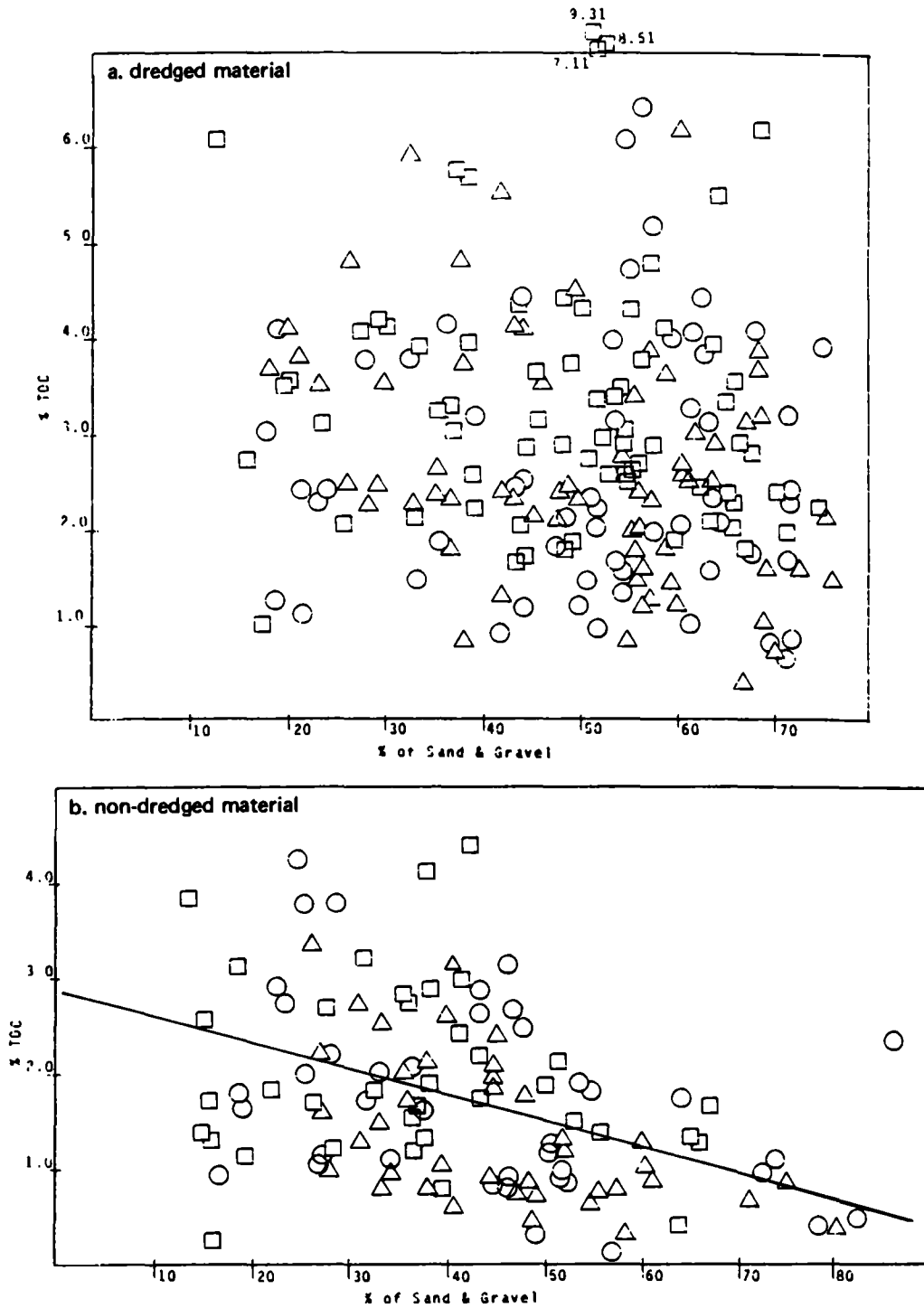

Figure 63. Plot of the Percent of TOC Versus the Grain Size of the Sediments for a) Dredged Material Samples and b) Non-Dredged Material Samples. Sediment texture is expressed as the percent of sand and gravel ( $\%<4\phi$ ), for Cruise 2,  $\circ$  ; Cruise 3,  $\triangle$  ; and Cruise 4,  $\square$  . Solid line in b) represents linear correlation line

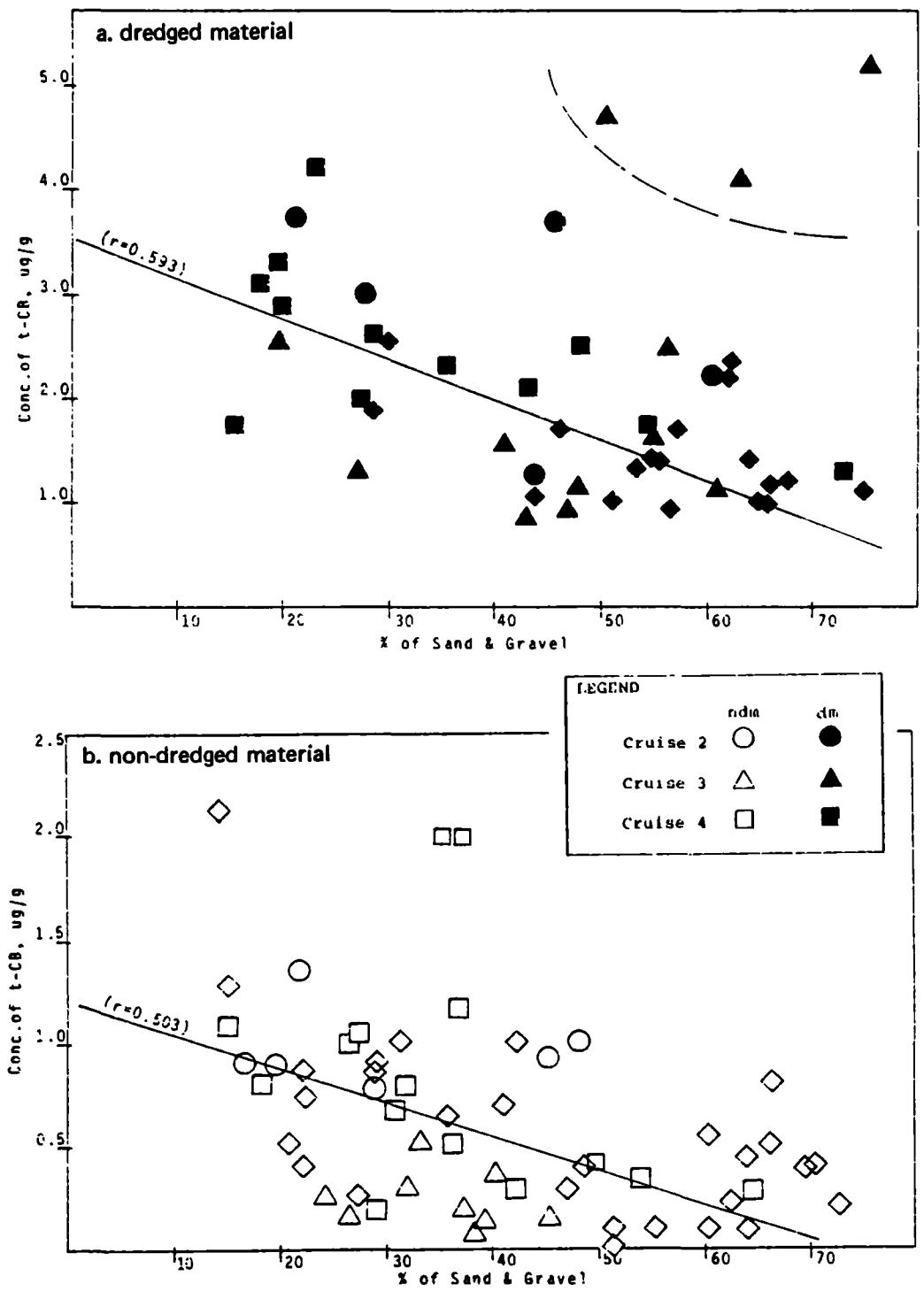

Figure 64. Plots of the t-CB Concentrations Versus the Grain Size of the Sediments for a) Dredged Material Samples and b) Non-Dredged Material Samples. Sediment texture is expressed as the percent of sand and gravel ( $\%_{<4\phi}$ ). The solid lines depict the linear regression correlations excluding outliers indicated by dashed lines

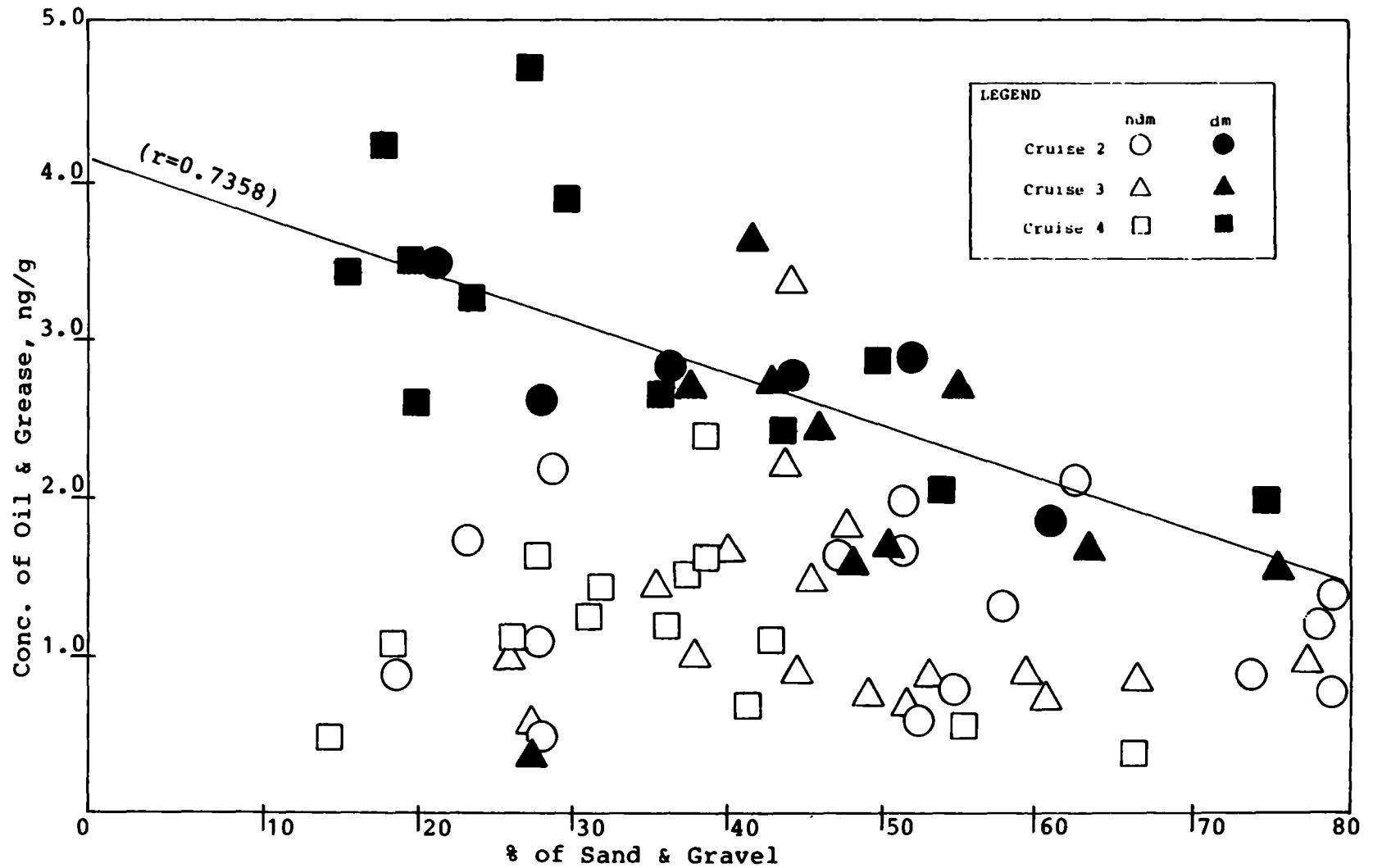

Figure 65. Plots of the Concentrations of O&G Versus the Grain Size of the Sediments. Sediment texture is expressed as the percent of sand and gravel ( $\%_{<4\phi}$ ). The solid line depicts the linear regression correlation for the dredged material

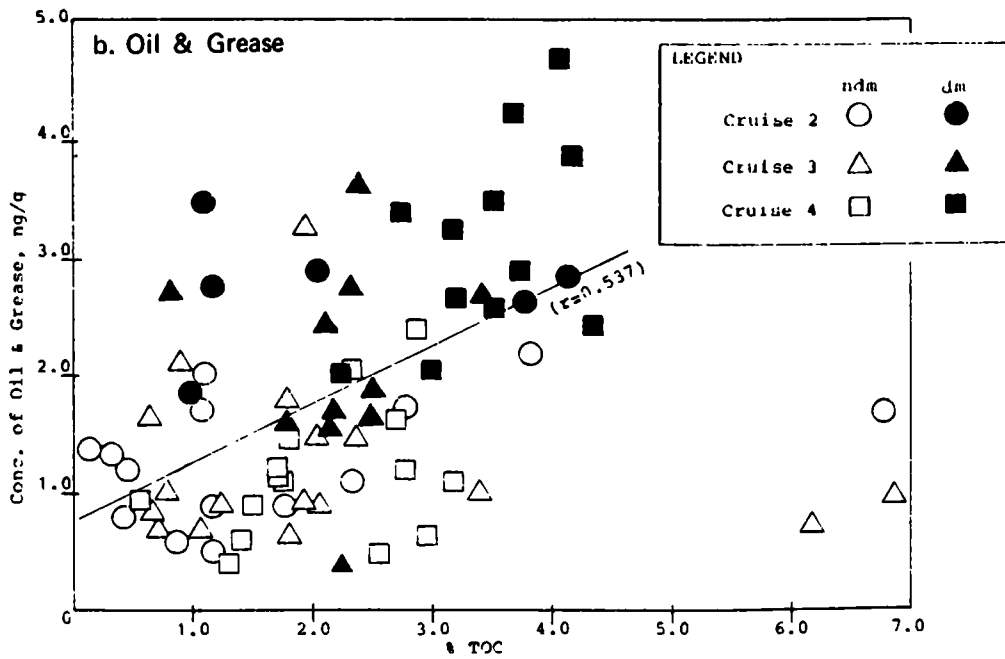
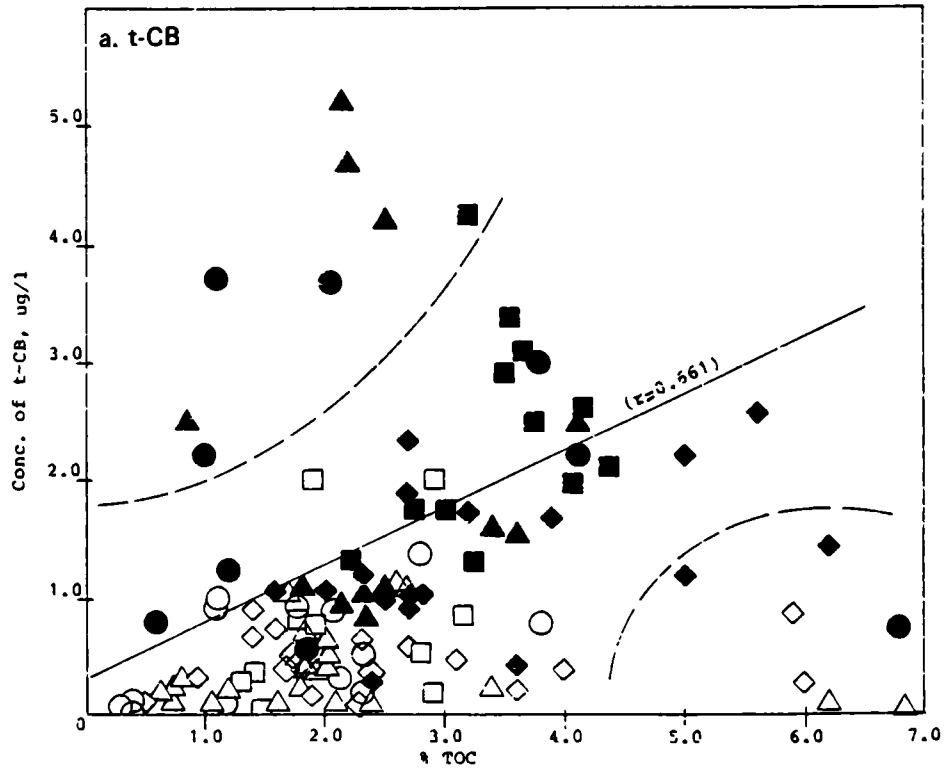

Figure 66. Plots of the Concentrations of t-CB and O&G Versus the Percent TOC of the Sediments. The solid line depicts the linear regression correlation for the dredged material, excluding the outliers indicated by the dashed lines

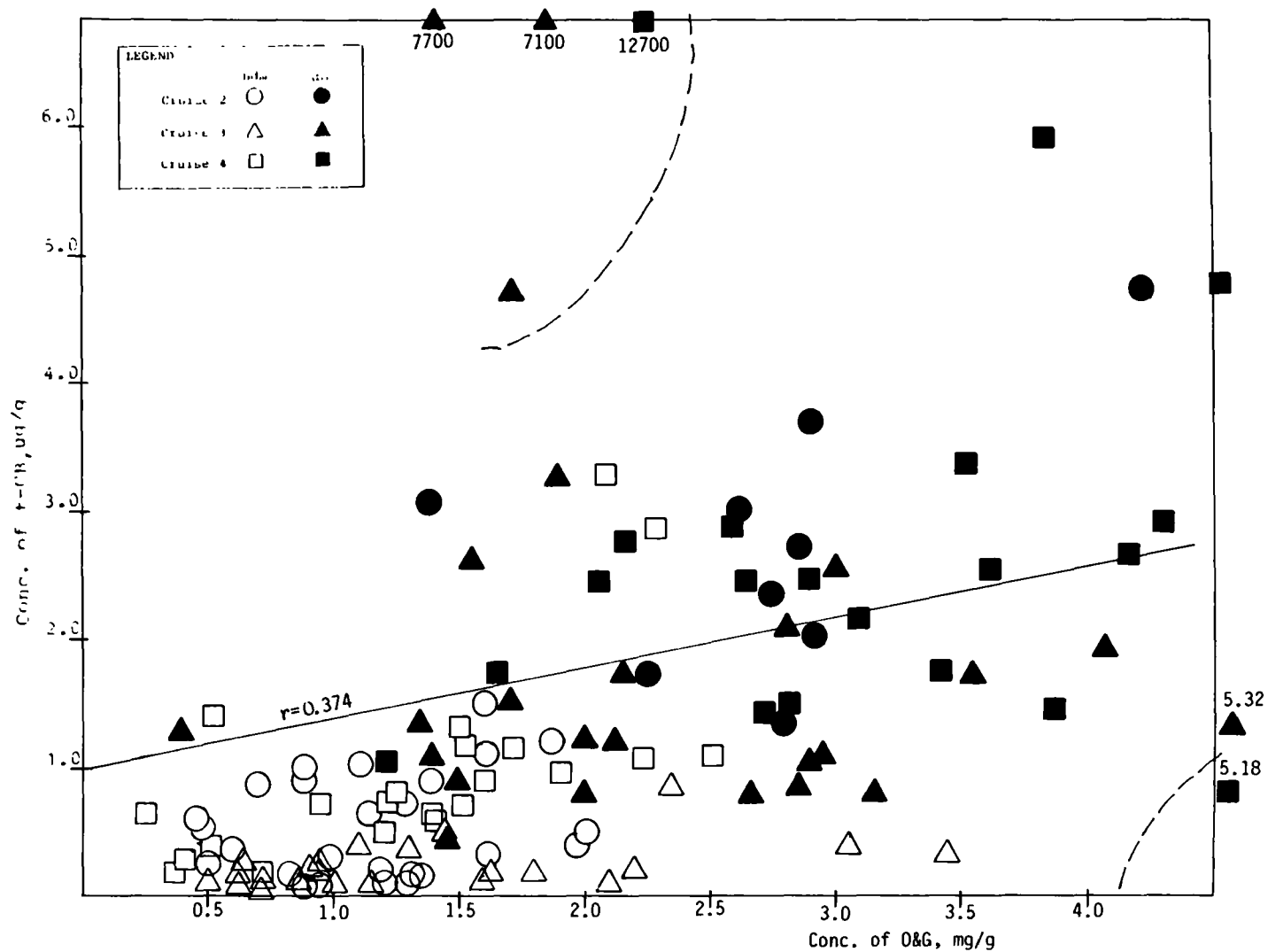

Figure 67. Plot of the Concentrations of t-CB Versus the Concentrations of O&G in the Sediments. The solid line represents the linear correlation line for the dredged material samples, excluding the outliers separated by the dashed lines

separating the sediments into these two major classifications. In addition, it should be noted that the TOC and sediment texture data were collected from broader horizons within the sediments than were the PCB and O&G data. As a result, correlations required the averaging of two to three horizons of the O&G and PCB data to achieve a comparable depth of sediments for comparison to the TOC and sediment texture data.

Overall, the data exhibited trends that agreed with the hypotheses, i.e., decreasing quantities of all organic constituents were observed with increasing percentages of coarse sediment particles (Figures 63-65); a tendency towards higher concentrations of both O&G and PCBs at greater TOC levels was noted (Figure 66); and the data also exhibited a correlation between the O&G and PCB concentrations (Figure 67).

At the same time, due to the high variability among samples, many of the correlations were not significant. Those relationships which showed a correlation significantly different from zero ( $>0.025$ ; Student's t-test) are depicted on the figures with linear correlation lines together with values of the correlation coefficients. In certain cases, significant correlations could be obtained only by excluding data that represented anomalously high or low values. In almost all cases, the scatter was quite large and, as a result, correlation coefficients were relatively low.

Figure 68 summarizes the results of these analyses and indicates which of the paired relationships yielded significant correlations and which did not. TOC was significantly correlated with sediment texture in the non-dredged material sediments, but not within the dredged material site. As mentioned earlier, the TOC values at certain stations may have been biased by the partial degradation of the large quantities of wood chips which were distributed throughout the sampling area, but were particularly associated with the dredged material. Within the dredged material, both O&G and PCB concentrations were significantly correlated with the sediment texture with the caveat that certain samples with very high concentrations of PCB had to be excluded from the data set to achieve significant correlation. In the non-dredged material sediments, the PCB concentrations, but not O&G, were also significantly



Dredged Material Sediments

	TOC	O&G	t-CB
% Sand & Gravel	-	+	(+)
TOC		+	(+)
O&G			(+)

Non Dredged Material Sediments

	TOC	O&G	t-CB
% Sand & Gravel	+	-	(+)
TOC		-	-
O&G			-

Figure 68. Summary of Correlations Between Physical and Chemical Parameters. A minus sign (-) indicates no significant correlation, a plus sign (+) indicates significant correlation, i.e., slope  $\neq 0$ ,  $\alpha < 0.025$ , Students t-test. The t-CB concentrations did correlate when selected data were excluded, for pairs indicated by (+)

correlated with sediment texture. In addition, within the dredged material sediments, TOC, O&G, and PCB appeared to all be mutually correlated, again with the exclusion of the certain high level PCB samples. In comparison, none of the organic parameters were correlated in the non-dredged material sediments.

Overall, these data suggest that both sediment texture and concentrations of non-PCB organic matter had a significant effect on the observed concentrations of PCBs within the sediments. These dependencies, however, were often overshadowed by differences in the sediment concentrations resulting from proximity to the sources of the constituents. Thus, for example, while the t-CB concentrations tended to be correlated with sediment texture both in the dredged material and in the non-dredged material samples, the slope and intercept of the linear regression equation for the former data were approximately twice that of the non-dredged material sediments, indicating much stronger inputs at the river site prior to dredging. Similarly, it can be argued that the stronger correlations seen among the organic constituents in the dredged material sediments was a reflection of the more homogeneous environment which existed in the river during the deposition of those sediments. In comparison, the relatively poor correlation among the organic constituents in the non-dredged material sediments may reflect not only normal sample variability, but also variability due to the much greater spatial extent of the sampling for these sediments.

#### PCBs in the interstitial waters

The concentrations of t-CBs and 3-CBs observed in the interstitial waters centrifuged from the surface sediments are plotted in Figure 69 versus the corresponding concentrations observed in the bulk sediments. The values from Cruise 2 appeared to have been biased by the carry-over of fine particulates in the interstitial water samples. The values from Cruise 2 were generally 2 to 10 times greater than observed in the samples from the later two cruises, which were filtered after centrifugation.

For Cruise 3, both the t-CB and 3-CB concentrations in the interstitial water exhibited a slight trend toward higher values corresponding

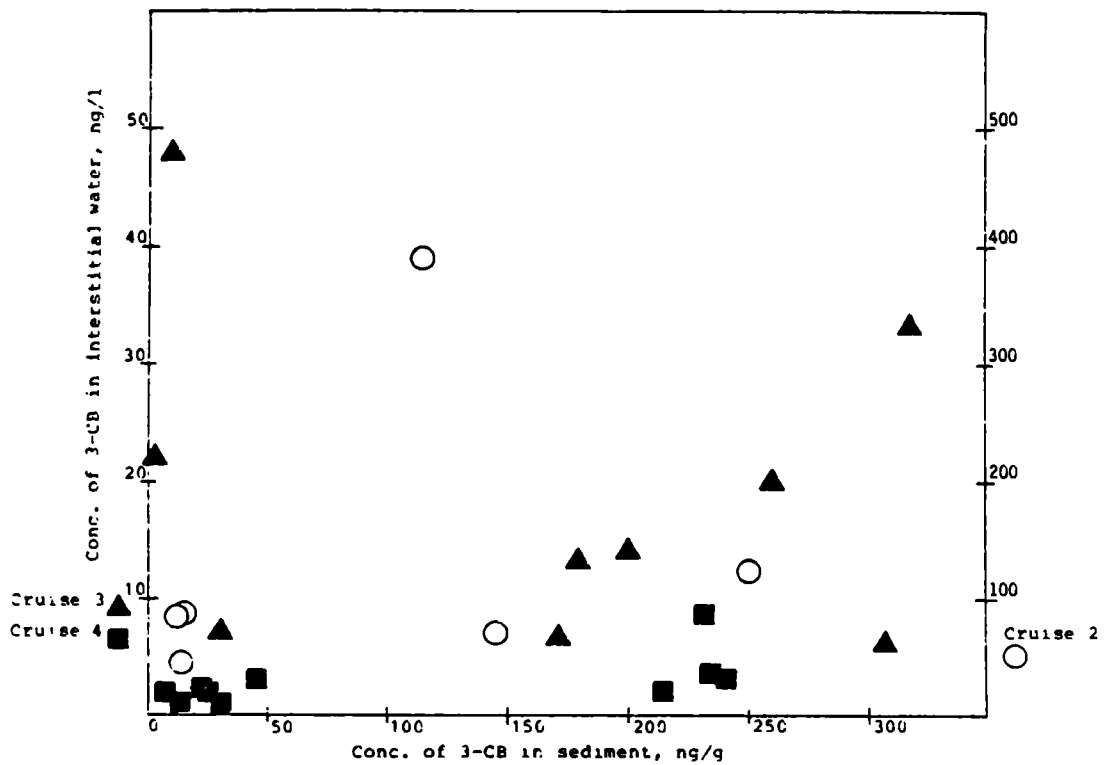
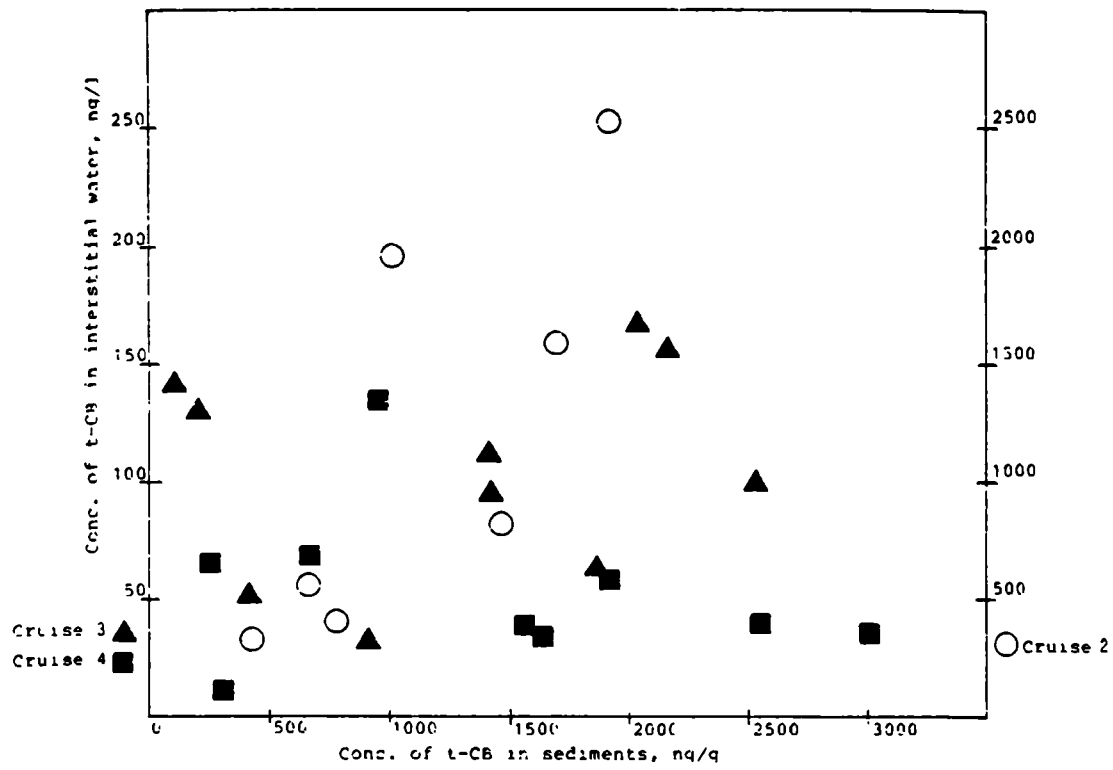

Figure 69. Concentrations of t-CB and 3-CB, ng/l, in Interstitial Water

to sediments of greater concentrations (Figure 69). However, a number of samples did not correspond to this trend, so that an overall correlation could not be clearly established. The measured interstitial water t-CB concentrations for Cruise 4 were largely invariant among samples and showed no dependence on the t-CB levels in the corresponding bulk sediments. The 3-CB concentrations for Cruise 4 interstitial waters also exhibited only a slight correlation with the corresponding sediment values. In addition, the interstitial water 3-CB concentrations were observed to be nearly an order of magnitude lower in May 1980 than those measured in October 1979, without comparable decreases in the corresponding concentrations of 3-CB in the sediments.

Overall, the lack of correlation between the PCB concentrations in the interstitial waters with those of the sediments and the high variability among samples and among cruises can probably be attributed largely to the difficulties in analyzing these samples. Only small quantities of water (200 to 500 ml) could be recovered from each sediment sample and, even with filtration, fine particulate material may have biased the samples toward higher concentrations. It might be noted that the decrease in the interstitial water PCB values with each successive cruise may simply reflect increased proficiency/experience in the analyses. The filters themselves have been tested previously and shown not to sorb PCBs (Dexter, 1976).

Thus, the accuracy or precision of these measurements cannot be clearly determined. However, similar PCB concentrations and a similar lack of dependence on the sediment levels were noted for the interstitial water samples from the previous study (Pavlou et al., 1978). While these two data sets are mutually supportive of the accuracy of the other, it is apparent that even the 10-fold increase in the sample volume analyzed for the recent samples was not sufficient to provide adequate analytical resolution.

#### Interstitial water sulfide and nutrients

Although the majority of the dredged material sediments were black in color, indicative of reducing conditions, free sulfide ( $S^{=}$ ) was detected at low levels in the subsurface horizons of only three, non-

dredged material cores. All of the samples were from fine sediments to the east of the dredged material deposit:

<u>Cruise</u>	<u>Core</u>	<u>Horizon cm</u>	<u>[S<sup>=</sup>] micromoles/liter</u>
2	131-1	10-13	35.9
		13-18	45.6
	139-1	3-6	7.0
		6-10	7.5
3	157-1	12-20	25.2
		20-25	285.0

Of the nutrients measured in the interstitial water, neither nitrate (NO<sub>3</sub>) nor nitrite (NO<sub>2</sub>) showed clear trends either among cores or with depth within the cores. Nitrate concentrations generally ranged from about 6 to 30 ug-at/l and were most commonly between 5 and 10 ug-at/l, compared with about 25 ug-at/l in the overlying water. Nitrite in the sediments was generally between 1 and 4 ug-at/l, roughly three times the values observed in the overlying water.

Reactive silicate (SiO<sub>4</sub>), orthophosphate (PO<sub>4</sub>), and ammonia (NH<sub>4</sub>) all behaved similarly and exhibited generally higher concentrations at depth in the cores. Table 29 presents the mean concentrations for these nutrients per horizon and per cruise, and for the dredged material cores and the background sediments.

SiO<sub>4</sub>, PO<sub>4</sub>, and NH<sub>4</sub> concentrations in the background sediments were similar among cruises. PO<sub>4</sub> and NH<sub>4</sub> were slightly higher at depth in the Cruise 4 samples (stations 152, 155, and 157), and SiO<sub>4</sub> was higher in the Cruise 3 samples (stations 145 and 148). These small differences appeared to reflect differences in the coring locations among the cruises. Samples were collected during Cruises 2 and 4 from south and east of the disposal site, while Cruise 3 samples were exclusively to the north of the site.

At the disposal site, silicate concentrations in the interstitial waters were similar to those observed in the background sediments during all cruises. Ammonia and phosphate, however, were both observed at much higher concentrations in the deeper sediments at the disposal site

TABLE 29. MEAN CONCENTRATIONS OF PO<sub>4</sub>, NH<sub>4</sub>, AND SiO<sub>4</sub> PER HORIZON PER CRUISE FOR THE INTERSTITIAL WATERS OF THE DREDGED MATERIAL AND NON-DREDGED MATERIAL SEDIMENTS

Horizon	n	Dredged Material			n	Non-Dredged Material		
		PO <sub>4</sub>	NH <sub>4</sub>	SiO <sub>4</sub>		PO <sub>4</sub>	NH <sub>4</sub>	SiO <sub>4</sub>
Cruise 2, May 1979								
1 (0-5 cm)	2	16	166	142	7	9.4+4.5	53+37	151+49
2 (5-10 cm)	2	84	384	190	7	18.0+10.3	109+34	197+57
3 (10-15 cm)	2	152	1210	316	6	23.4+16.9	130+54	247+72
4 (15-20 cm)	2	81	1695	204	6	25.3+8.4	168+75	243+90
5 (20-25 cm)	2	66	1978	221	5	27.7+19.6	168+112	264+111
Cruise 3, Oct 1979								
1 (0-5 cm)	6	17.7+9.8	47+15	172+24	4	24.9+15.8	59+9	350+80
2 (5-10 cm)	6	41.7+18.7	93+26	206+24	4	45.5+28.6	156+27	464+56
3 (10-15 cm)	6	64.7+35.3	68+39	257+78	4	29.3+11.8	174+24	528+44
4 (15-20 cm)	6	42.1+22.7	132+78	319+97	4	35.0+9.9	181+29	559+39
5 (20-25 cm)	6	39.6+31.3	160+79	314+115	4	29.0+16.5	172+42	629+37
Cruise 4, May 1980								
1 (0-5 cm)	4	25.5+18.1	113+21	135+6	6	13.7+11.9	60+50	140+42
2 (5-10 cm)	4	121.5+47.9	341+110	227+67	6	37.9+23.1	151+105	221+69
3 (10-15 cm)	4	207.9+14.3	961+125	343+36	6	48.9+42.0	195+116	250+113
4 (15-20 cm)	3	237.9+30.9	1830+486	443+59	4	69.5+16.0	314+251	273+76
5 (20-25 cm)	3	94.2+93.2	2356+744	288+78	4	65.3+32.9	292+172	245+60

during Cruises 2 and 4 than in the background sediments during these cruises. The samples of dredged material from Cruise 3 had  $\text{NH}_4$  and  $\text{PO}_4$  concentrations similar to the background sediments and lower than observed during the two May cruises.

Variability within the site sediments appears to be the most reasonable explanation for the differences in the nutrient concentrations between the October cruise and those in May. However, the consistency of  $\text{NH}_4$  and  $\text{PO}_4$  in the dredged material cores within each cruise is surprising if spatial variability is the explanation. As can be seen in part by the standard deviations, all six cores from the May cruises yielded high  $\text{NH}_4$  and  $\text{PO}_4$  concentrations, while all six cores from the October cruise were relatively low.

No obvious relationships existed between the concentrations of interstitial water nutrients and other physical or chemical characteristics of the sediments, except that higher concentrations were associated with dredged material which also had overall slightly higher concentrations of PCBs, TOC, and O&G.

### Water Column Studies

#### Standard hydrographic parameters

The standard hydrographic and nutrient parameters collected during cruises 2 through 4 are summarized per cruise in Table 30. To show the major spatial distributions, the data are presented as means per sampled depth of the disposal site stations and for stations collected away from the disposal site.

Salinity and temperature. The salinity values indicated that during all three cruises the water column exhibited typical vertical stratification with strong gradients in the upper few meters overlying higher salinity but more uniform deep water. In response to the seasonal inputs of fresh water to Puget Sound, both May cruises exhibited lower salinities at all depths and stronger salinity gradients on the surface layers than were observed in October. Similarly, both May cruises had cooler water throughout the water column than observed in October: May bottom water values ranged from 8-9°C compared to 12°C observed in October. For all cruises, top to bottom temperature ranges

TABLE 30. MEAN CONCENTRATIONS PER CRUISE OF STANDARD  
HYDROGRAPHIC AND NUTRIENT PARAMETERS

Depth, m	Salinity, ‰	Dissolved Oxygen, ml/l	$\text{NH}_4^-$ , ug-at/l	$\text{PO}_4$ , ug-at/l	$\text{NO}_3$ , ug-at/l	$\text{SiO}_4$ , ug-at/l	
							Cruise 2, May 1979
			<u>Disposal Site Stations (n=4)</u>				
0	26.241±2.097	6.53±0.01	0.135±0.107	2.27±0.07	23.4±0.1	55.2±5.2	
5	29.390±0.035	6.43±0.02	0.006±0.005	2.13±0.09	23.3±0.4	53.8±0.9	
15	29.542±0.019	6.32±0.02	0.010±0.006	2.15±0.10	23.8±0.6	53.8±0.9	
-10	29.607±0.005	6.12±0.03	0.018±0.009	2.13±0.08	24.4±0.7	54.4±0.4	
-1	29.025±0.017	6.10±0.02	0.022±0.020	2.31±0.04	25.1±0.5	54.5±0.6	
			<u>Non-Disposal Site Stations (n=8)</u>				
0	24.134±4.509	6.65±0.22	0.624±0.593	2.25±0.33	21.1±4.5	73.7±26.2	
5	29.246±0.361	6.59±0.11	0.018±0.017	2.04±0.17	21.3±5.0	49.4±12.2	
15	29.557±0.011	6.40±0.07	0.021±0.025	2.11±0.14	22.6±4.0	50.0±9.0	
-10	29.664±0.128	6.13±0.12	0.044±0.022	2.29±0.07	26.0±0.4	55.5±0.6	
-1	29.718±0.156	6.13±0.20	0.051±0.035	2.20±0.21	24.6±3.4	52.0±6.8	

(Continued)



TABLE 30 (CONT'D)

<u>Depth, m</u>	<u>Salinity, ‰</u>	<u>Dissolved Oxygen, ml/l</u>	<u>NH<sub>4</sub><sup>-</sup>, ug-at/l</u>	<u>PO<sub>4</sub>, ug-at/l</u>	<u>NO<sub>3</sub>, ug-at/l</u>	<u>SiO<sub>4</sub>, ug-at/l</u>
Cruise 3, Oct 1979						
<u>Disposal Site Stations (n=5)</u>						
0	29.671±0.342	5.18±0.03	4.86±1.82	2.50±0.21	18.9±1.2	49.0±4.5
5	30.419±0.024	5.20±0.07	0.93±0.09	2.55±1.03	17.9±0.5	44.4±2.9
15	30.527±0.006	4.93±0.09	1.12±0.08	2.56±1.06	17.8±0.4	43.2±0.3
-10	30.634±0.050	4.25±0.22	0.26±0.21	2.28±0.17	21.2±2.4	46.7±5.4
-1	30.703±0.046	4.06±0.14	0.16±0.09	2.45±0.09	22.6±0.7	49.8±1.1
<u>Non-Disposal Site Stations (n=8)</u>						
0	29.680±0.270	5.12±0.20	4.93±1.56	2.49±0.17	18.9±1.3	50.2±4.2
5	30.357±0.119	5.25±0.08	1.20±0.56	2.16±0.09	17.8±1.1	46.9±3.1
15	30.511±0.043	4.95±0.06	1.00±0.13	2.13±0.09	17.7±1.2	44.6±3.2
-10	30.693±0.108	4.20±0.23	0.31±0.31	2.30±0.12	21.5±1.9	49.5±4.5
-1	30.742±0.094	4.11±0.18	0.28±0.16	2.43±0.08	23.1±1.2	53.7±2.2

(Continued)

TABLE 30 (CONT'D)

<u>Depth, m</u>	<u>Salinity, ‰</u>	<u>Dissolved Oxygen, ml/l</u>	<u>NH<sub>4</sub><sup>-</sup>, ug-at/l</u>	<u>PO<sub>4</sub>, ug-at/l</u>	<u>NO<sub>3</sub>, ug-at/l</u>	<u>SiO<sub>4</sub>, ug-at/l</u>
Cruise 4, May 1980						
<u>Disposal Site Stations (n=4)</u>						
0	25.643+1.229	7.43+0.17	7.22+1.68	1.57+0.19	8.0+1.3	35.5+9.8
5	27.894+0.413	7.87+0.08	2.73+0.64	1.22+0.16	6.1+1.3	20.6+4.0
15	28.641+0.112	7.42+0.17	2.69+0.41	1.49+0.20	10.6+2.4	25.7+5.0
-10	29.117+0.025	6.45+0.31	2.99+0.34	2.06+0.13	18.7+1.2	39.7+1.2
-1	29.220+0.065	6.15+0.10	3.03+0.95	2.25+0.34	17.9+3.1	41.6+3.7
<u>Non-Disposal Site Stations (n=8)</u>						
0	25.187+1.065	7.38+0.09	6.32+1.77	1.62+0.15	10.1+1.2	45.4+8.4
5	28.245+0.897	7.72+0.21	1.94+0.52	1.17+0.08	6.8+0.7	20.9+2.5
15	28.725+0.143	7.23+0.22	1.87+0.40	1.45+0.11	10.8+2.4	25.8+4.2
-10	29.265+0.125	6.10+0.21	2.06+0.36	2.03+0.16	19.9+2.9	43.3+5.7
-1	29.369+0.071	5.92+0.12	2.30+0.69	2.08+0.11	21.0+2.2	44.6+4.2

were limited to approximately 1°C. During all three cruises, no differences were noted between the salinities or temperature at the disposal site and stations away from the disposal site with the exception of changes which could be attributed to proximity to the effluent of the Duwamish River and/or variations of depth between the stations.

Dissolved oxygen. The dissolved oxygen (DO) concentrations also exhibited typical vertical profiles with higher values at the surface and lower values at depth, reflecting respiratory oxygen utilization. In addition, the DO values also exhibited seasonal variations. In May 1979, surface DO values were approximately at saturation levels and the levels decreased to approximately 90 percent of saturation in the deep water. In comparison, in October 1979, DO concentrations were lower throughout the water column with a saturation gradient ranging from 85 to 90 percent at the surface to approximately 65 to 70 percent at depth. Finally, in May of 1980, the DO values indicated the effects of an algal bloom, with the oxygen concentrations showing supersaturation of approximately 110 to 120 percent at the surface, decreasing to approximately 90 percent at depth.

Nutrients. Phosphate, nitrate, and silicate concentrations exhibited generally small gradients from the surface to the bottom. Concentrations were often highest in the brackish surface layer (apparently reflecting the inputs associated with the fresh water from the Duwamish River), lowest in the shallow subsurface depths, and increasing again in the deep water. The  $\text{NH}_4$  concentrations exhibited much stronger gradients, with high values in the surface layer decreasing to more uniform and much lower values in the deep water. While there were changes among the cruises, within each cruise the  $\text{NH}_4$  concentrations were quite strongly correlated with salinity (Figure 70).

In addition, the overall levels of the nutrients showed interesting temporal trends.  $\text{PO}_4$ ,  $\text{NO}_3$ , and  $\text{SiO}_4$  were highest in May 1979 and decreased with each successive cruise. In comparison,  $\text{NH}_4$  showed essentially the opposite trend. Together with the salinity and dissolved oxygen variations, these changes apparently reflect the effect of varying inputs of the nutrients, particularly  $\text{NH}_4$ , with the discharge

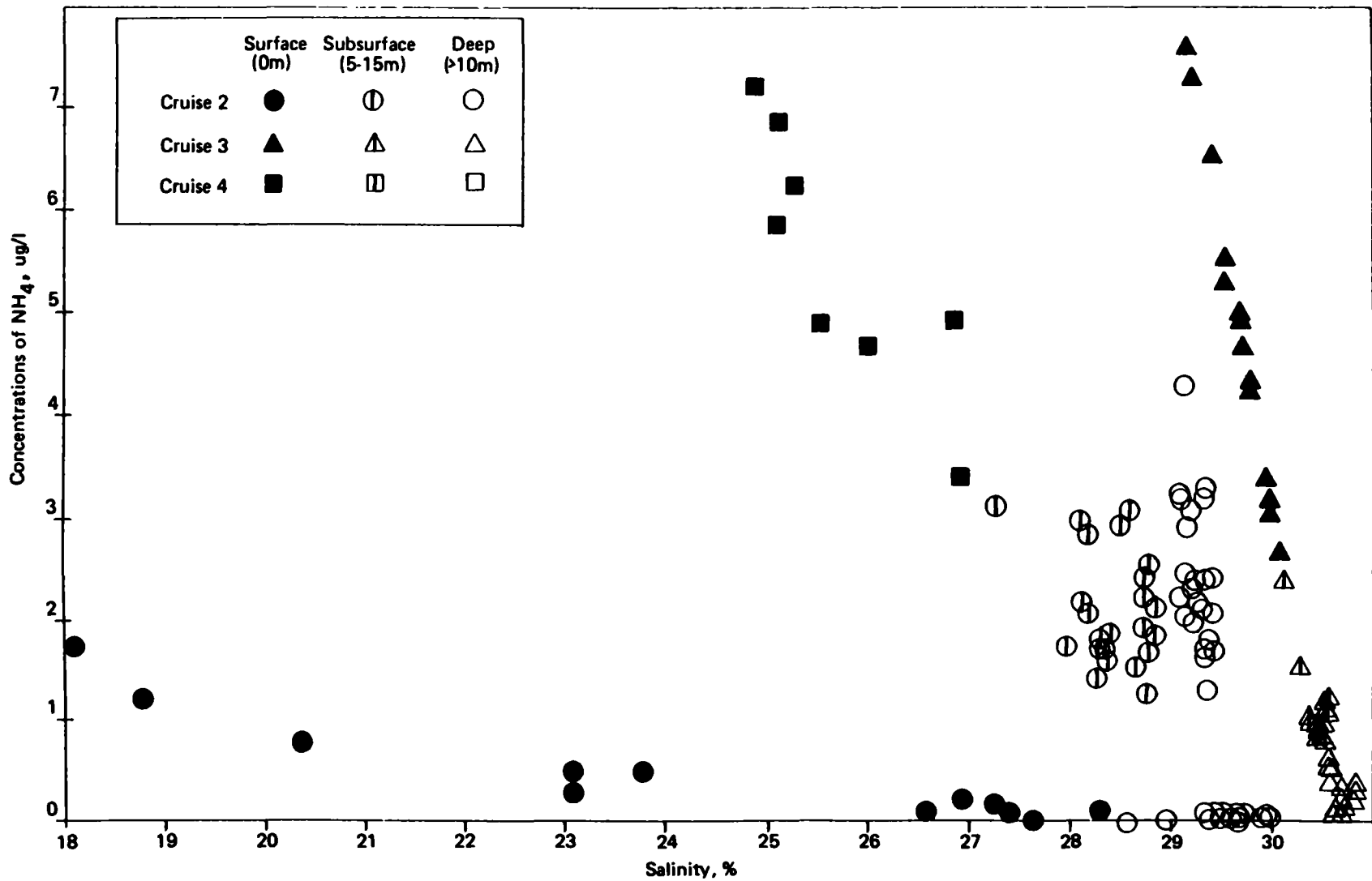

Figure 70. Concentrations of NH<sub>4</sub> in the Water Column as a Function of Salinity, Cruises 2, 3, and 4

of the Duwamish River and changes in the biological activity within Elliott Bay. The data from May 1979 appear to reflect limited primary productivity occurring during this period. DO values were essentially at equilibrium with atmospheric concentrations while the concentrations of the nutrients appeared to reflect remineralization which occurred during the winter.

In comparison, the data from October 1979 reflect the effects of the summer growth period and the onset of remineralization in the fall: most nutrient levels were lower than in the spring,  $\text{NH}_3$  values had increased, and, at the same time, DO values had been depressed due to respiration throughout the water column.

Finally, in May 1980, the data were consistent with the onset of high levels of primary production as indicated by the marked decrease in the concentrations of  $\text{PO}_4$ ,  $\text{NO}_3$ , and  $\text{SiO}_4$  and the supersaturation of oxygen within the surface layers. At the same time some immediate remineralization of nitrogen appeared to have occurred, leading to the high levels of  $\text{NH}_4$  within the water column. Similar production of  $\text{NH}_4$  coincident with high primary production had been observed previously in the main basin of Puget Sound (Collias, 1976).

Overall, the concentrations of the hydrographic and nutrient parameters and the temporal variations in these levels among cruises appeared to reflect the normal responses to seasonal processes occurring within Puget Sound. In particular, they did not indicate site-specific variations resulting from exchange with the sediments at the disposal site: none of the parameters exhibited significant differences between disposal site stations and those away from the disposal site. Similarly, there were no major differences noted between the two bottom horizons, which could be attributed to strong diffusion of nutrients from the bed sediments.

#### PCBs in the water column

The concentrations of t-CB observed in the water and associated with the suspended particulate matter (SPM) during Cruises 2 through 4 are summarized per cruise in Table 31. As was the case with the hydrographic and nutrient parameters, the PCB data are summarized as the

TABLE 31. MEAN CONCENTRATIONS OF t-CB IN THE WATER AND ASSOCIATED WITH THE SUSPENDED PARTICULATE MATTER

Depth	WATER t-CB water, ng/l		PARTICULATES t-CB SPMs, ng/g	
	DS <sup>a</sup>	NDS <sup>a</sup>	DS	NDS
Cruise 2, May 1979				
-10 <sup>b</sup>	2.5+0.7(3) <sup>c</sup>	2.6+1.0(6)	417+125(4)	720+147(8)
-1 <sup>b</sup>	3.7(1)	2.2+1.1(6)	1352+705(4)	1033+583(8)
Cruise 3, October 1979				
-10	0.8+0.4(5)	0.8+0.5(8)	142+42(5)	138+41(8)
-1	0.6+0.3(5)	0.7+0.9(8)	154+56(5)	200+144(8)
Cruise 4, May 1980				
-10	2.8+2.1(4)	1.2+0.9(6)	976+231(3)	1494+721(6)
-1	1.3+0.3(4)	1.3+0.6(8)	1129+553(4)	926+423(8)

a DS indicates disposal site stations; NDS indicates non-disposal site stations

b -10 = 10 m above the bottom; -1 = 1 m above the bottom

c Data are presented as the means and standard deviations. Numbers in parentheses indicate number of samples in mean.

means per sampled depth for those stations over the disposal site and for a separate grouping of those stations away from the disposal site.

Due to the sampling and analytical difficulties in measuring PCBs at the very low levels observed in these matrices, the measured concentrations were characterized by very high variability among the samples and in certain cases by errors associated with unresolvable non-PCB constituents in the analyses. Due to the latter problem, a number of samples, occurring randomly in the data set, appeared to contain anomalously high PCB concentrations. As a result, water samples which had measured concentrations greater than 5 ng/l (parts per trillion) were considered suspect and were deleted from the data analysis. Similarly, SPM samples having concentrations in excess of 5 ug/g were also deleted. The remaining values were consistent with the data obtained in other studies in the Sound (Dexter et al., 1981).

With these restrictions on the data, the mean PCB concentrations were often observed to be higher in the deep water than in the samples 10 m off the bottom. However, these differences were not large, were not consistent among all stations, and, most importantly, were not statistically significant. Similarly, for all cruises, neither the PCB-water nor the PCB-SPM concentrations were statistically different when comparisons were made between the disposal site samples and those from non-disposal site stations. As a result, the data gave no indication that losses of PCBs associated with either diffusional or erosional movement were occurring from the disposal site. These results thus agree with the conclusions of the sediment physical and chemical studies discussed earlier.

At the same time, temporal variations were noted in both data sets, with higher concentrations of PCBs observed in both May cruises than in the October cruise. Since this trend was similar to that observed for the freshwater content, i.e., the inverse of salinity, and since the rivers were recognized sources of PCBs to Puget Sound, this relationship was tested further. To eliminate the high variability of the individual samples, overall mean PCB concentrations were plotted against the average deepwater salinities for each cruise (Figure 71). The PCB concentrations both in the water and associated with the SPM showed surprisingly strong inverse correlations with salinity ( $r^2 = 0.83$  ml 0.72 for water and SPM, respectively), although it must be recognized that the high variability in the samples and the relatively low range of salinities did not fully establish this trend.

In attempting to compare the long-term temporal trends between the recent PCB data in the water column and that collected during the original study (Pavlou et al., 1978), it was observed that not only were the levels approximately comparable between the two studies, but, in addition, a similar relationship with salinity was noted. The data from the previous study were therefore included in Figure 71, as the overall means per cruise of the disposal site stations. Interestingly, both the older and the more recent data sets appeared to describe nearly identical trends with decreasing PCB concentrations associated with the higher salinity water. While this trend was not completely unexpected, having

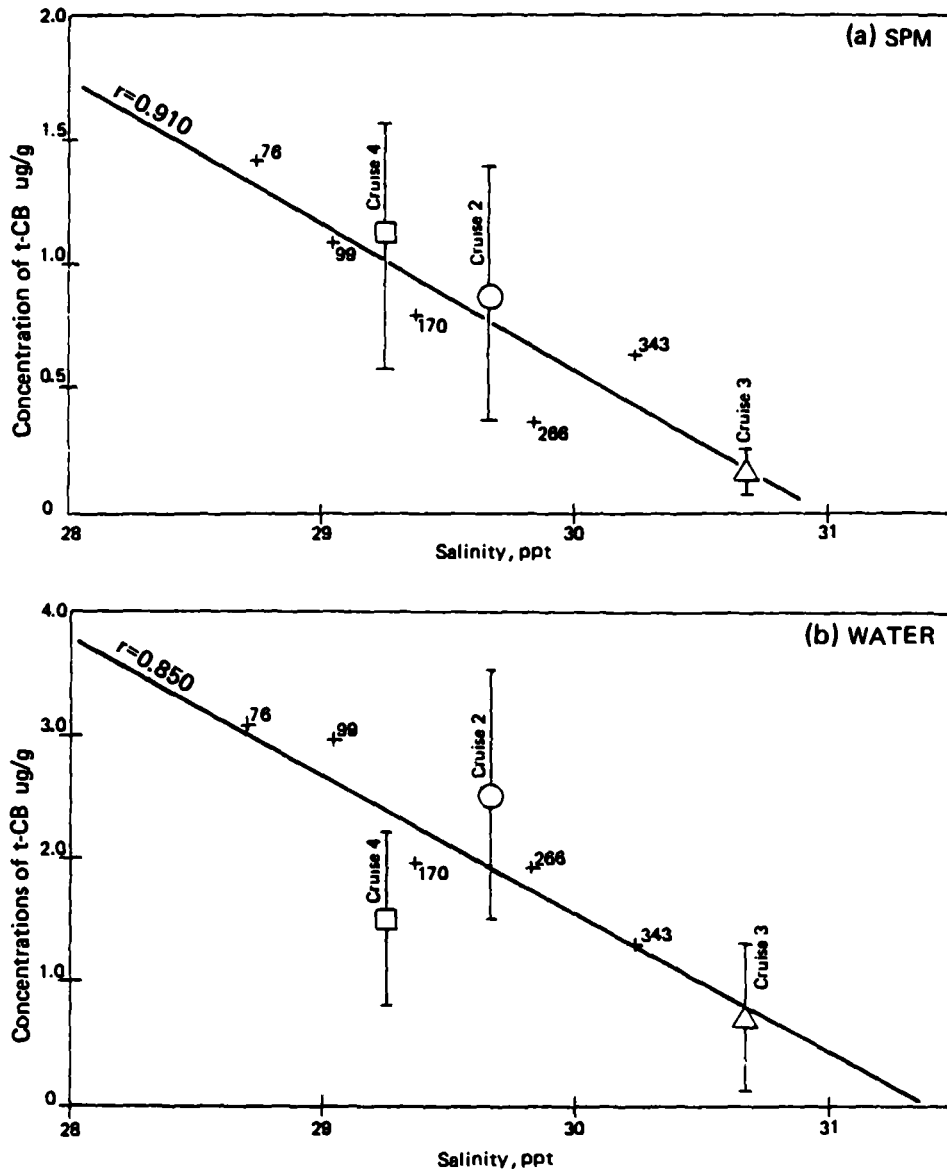

Figure 71. Plots of the Mean Concentrations of t-CB Observed in the (a) Suspended Particulate Matter and (b) Water Versus Salinity. Open symbols depict data from recent cruises as overall means and standard deviations (vertical lines). Crosses depict data from Pavlou et al. (1978); numbers refer to Julian dates of the collection of these samples. Solid lines on (a) and (b) indicate linear correlation fit of the data



been observed in the surface waters as the conservative mixing of high-PCB riverine water with lower concentration seawater (Pavlou and Dexter, 1979), it has not before been observed in the deep water nor as a long-term relationship in the PCB concentrations within the Sound.

While this trend certainly cannot be considered fully established, the data indicated a rather interesting long-term response of the system. The PCB concentrations within Elliott Bay probably were reflecting an overall response of the Sound to varying PCB inputs and, in particular, indicated that the values within the deep water are not related to the dredged material deposit.

#### Summary of Abiotic Chemical Studies

Spatial comparisons demonstrated that the dredged material contained higher concentrations of PCBs, total organic carbon, O&G, and interstitial water nutrients than were observed in the background sediments in the study area. While the dredged material could be clearly delineated on the basis of a combination of proximity to the mound observable in the bathymetry, the black sediment color, particular grain-size patterns, and the type of PCBs associated with the material, the majority of the chemical parameters were not greatly different from those observed in the surrounding area. In addition, if one includes values obtained in other studies from Elliott Bay (Pavlou and Dexter, 1979; Malins et al., 1980), it must be concluded that, overall, the disposal site does not constitute a particularly unique environment in Elliott Bay. In particular, concentrations of the parameters which are equal to or exceed those observed at the disposal site have been observed in other areas of Elliott Bay.

No changes in the concentration of any parameter within the dredged material could be demonstrated, based on comparisons among cruises or among horizons, with the exception of interstitial water nutrients. Differences in the latter probably resulted from variations in spatial locations. Similarly, no long-term changes could be demonstrated from an analysis of the data for non-dredged material sediments.

The conclusions drawn from the sediment analyses were supported by the water column data, which, while exhibiting significant temporal changes, indicated that these changes were in response to seasonal differences in the inputs to Elliott Bay/Puget Sound and normal biological activity. In particular, no significant differences in concentrations which could be considered to be specific responses to the disposal site were noted in the water column data.

Together with the lack of physical disturbances, i.e., erosion of the dredged material, as was established previously, these chemical data argue quite convincingly that PCBs and the other organic chemical parameters associated with the dredged material are stable over the long term. Of particular importance from a dredged material management perspective is the fact that no diffusional losses of PCBs were detectable even from the surface sediments. These data thus argue for the long-term stability and isolation of contaminated dredged material as long as the physical integrity of the disposal site is maintained.

#### Uptake of PCBs by Benthic Organisms

Samples for the determination of the PCB concentrations in the benthic macrofauna were collected during the May and October 1979 and the May 1980 cruises. Due to the difficulty in obtaining sufficient biomass (10 to 14 van Veen grab samples were required to obtain sufficient sample for the PCB analyses), accurate and precise determinations of a number of parameters of the organisms, e.g., lipid weights, could not be obtained. Therefore, the PCB concentrations are discussed below on the basis of the dry mass of the biota.

A variety of species and taxa were collected during each cruise, more than could be analyzed for PCBs. Table 32 shows the organisms which were obtained per station and per cruise and also indicates which of these were analyzed for PCB content. During the May 1979 cruise, we were not as experienced in the collection of the organisms from this site and also had no prior information as to which organisms could be collected in sufficient quantity for analysis. As a result, fewer organisms were collected at all stations, but more species were analyzed. On the basis of the information obtained from Cruise 2, the collection

TABLE 32. BENTHIC MACROFAUNA SAMPLES OBTAINED FROM ALL CRUISES<sup>a</sup>

Taxa	Cruise 2, May 1979					Cruise 3, October 1980					Cruise 4, May 1980				
	Station					Station					Station				
	103	109	131	133	139	100	103	109	145	148	100	103	152	155	157
<u>Capitellidea</u> sp.	X		X			X	X	X	X		X	XX	XX	X	X
<u>Glycera capitata</u>	XXX	X	X	X		X	X	X	X	X	XX	X	X	X	XX
<u>Laonice cirrata</u>			X			XX		XX	X	XX	XX	X	X	XX	X
Bivalves ( <u>Macoma</u> and <u>Axinopsida</u> spp.)		X		X	X	XX	XX	XX	X	X	XX	XXX	XXX	XX	XX
<u>Goniada brunnea</u>	X		X					XX	X	X	X	XX	X	X	XX
<u>Glycera americana</u>						X	XX	X	X	X					
<u>Onuphis irridescens</u>	X	X	X	X	X		X	X	X	X	X	X	X	X	X
Shrimp sp.						X			X	XX	X	X		X	X
Nemertea sp.			X					X	X	X	X	X	X		X
Holothuridae sp.	X	X	X	X		X	XX			X	X	X	X	X	
<u>Asychis similis</u>								X	X	X					
<u>Ammotrypane alougaster</u>										X					
<u>Praxiella gracilis</u>									X	X			X		
Sipunculid sp.		X				X		X	X		X	X	X		X
<u>Nemocardium centrifolsum</u>													X		X
Polynoidea sp.	X														
Maldaridae sp.		X		X											

<sup>a</sup> More than one x indicates replicates were collected.

procedures were modified as noted in the methodology section. In addition, preliminary selection of the organisms desired for further study was made. It appeared we could rely on obtaining sufficient quantities at most stations of at least the polychaetes Capitellidae spp., detritivores, and Glycera capitata, a carnivore; and the bivalves, Macoma spp. and Axinopsida spp., both also detritivores. In addition, we supplemented these taxa with additional polychaetes species. In October 1979, this selection included Laonice cirrata, a detritivore, and Glycera americana, a carnivore. Laonice cirrata was also sufficiently abundant in May 1980; however, G. americana was not. Therefore, Goniada brunnea was analyzed as an additional carnivore. Finally, sufficient benthic shrimp, species undetermined but probably surface deposit feeders, were collected in May 1980 to warrant their analysis. These latter organisms are physiologically quite different from the worms and bivalves and also are considered a favored food of demersal fish.

While considerable variability was observed in the PCB concentrations, the data were adequate to consider two aspects of the PCB levels in the benthic biota: 1) the relationship between the PCB concentrations in the organisms with the levels in the sediments, and 2) the differences in the PCB concentrations among different species.

#### PCB concentrations in the organisms versus concentrations in the sediments

The general trends observed in the biota are presented in Table 33 as the average PCB concentrations (for both t-CB and 3-CB) for each station and each cruise. The averages were not weighted for any species but excluded the data for Goniada brunnea, a carnivorous errantian polychaete, and for the bivalves. G. brunnea appeared to have anomalously high PCB concentrations while the bivalves were not corrected for shell weight for the May 1979 cruise. Both organisms are discussed separately below.

Also included in Table 33 are the ambient t-CB and 3-CB concentrations from the sampling sites expressed as the averages of the surface sediment samples collected from the van Veens together with the data from the upper two horizons from the core samples from the same stations (upper 5 to 6 cm of the sediment cores). The data in Table 33 are plotted in Figure 72 for both the t-CB and 3-CB data.

TABLE 33. COMPARISONS OF THE AVERAGED t-CB AND 3-CB CONCENTRATIONS OBSERVED IN THE BENTHIC ORGANISMS AND THE SEDIMENTS FOR ALL CRUISES

Sample Station	PCB Concentrations, ng/g dry weight			
	Biota		Sediments	
	<u>3-CB</u>	<u>t-CB</u>	<u>3-CB</u>	<u>t-CB</u>
Cruise 2, May 1979				
103(8) <sup>a</sup>	576+631 <sup>b</sup>	3906+3029	406+317	2585+1237
109(5)	72+107	2029+2699	45.6+36.7	431+306
(4) <sup>c</sup>	(25+18) <sup>c</sup>	(842+561) <sup>c</sup>		
131(6)	160+120	1560+888	78+44	806+421
133(4)	15.1+16.6	457+388	18.6+8.4	594+291
139(1)	0.7	210	15.5+4.9	955+348
Cruise 3, Oct 1979				
100(5)	136+78	1716+1091	446+323	3012+2471
103(4)	211+39	3515+2663	411+228	3328+2225
109(5)	71+31	847+479	221+136	1563+722
145(4)	6.6+4.8	209+127	46+62	442+259
148(4)	3.9+2.1	203+121	6.1+3.0	160+40
Cruise 4, May 1980				
100(6)	253+252	2477+1925	415+233	2725+1639
103(5)	283+295	2446+1560	347+218	1830+812
152(4)	43+59	475+324	40+45	315+194
155(4)	17+14	403+100	68+29	821+338
157(4)	106+155	1079+1161	19.2+6.8	1752+1102

a Numbers in parentheses represent the number of organisms per sample (includes replicate samples of some organisms) which constituted the averages for the biota. Six samples constitute each average for the sediments.

b Averaged concentrations + one standard deviation. All averages for the biota exclude data for Goniada brunnea and bivalves.

c Average values at Station 109 if one high value for Glycera capitata is excluded.

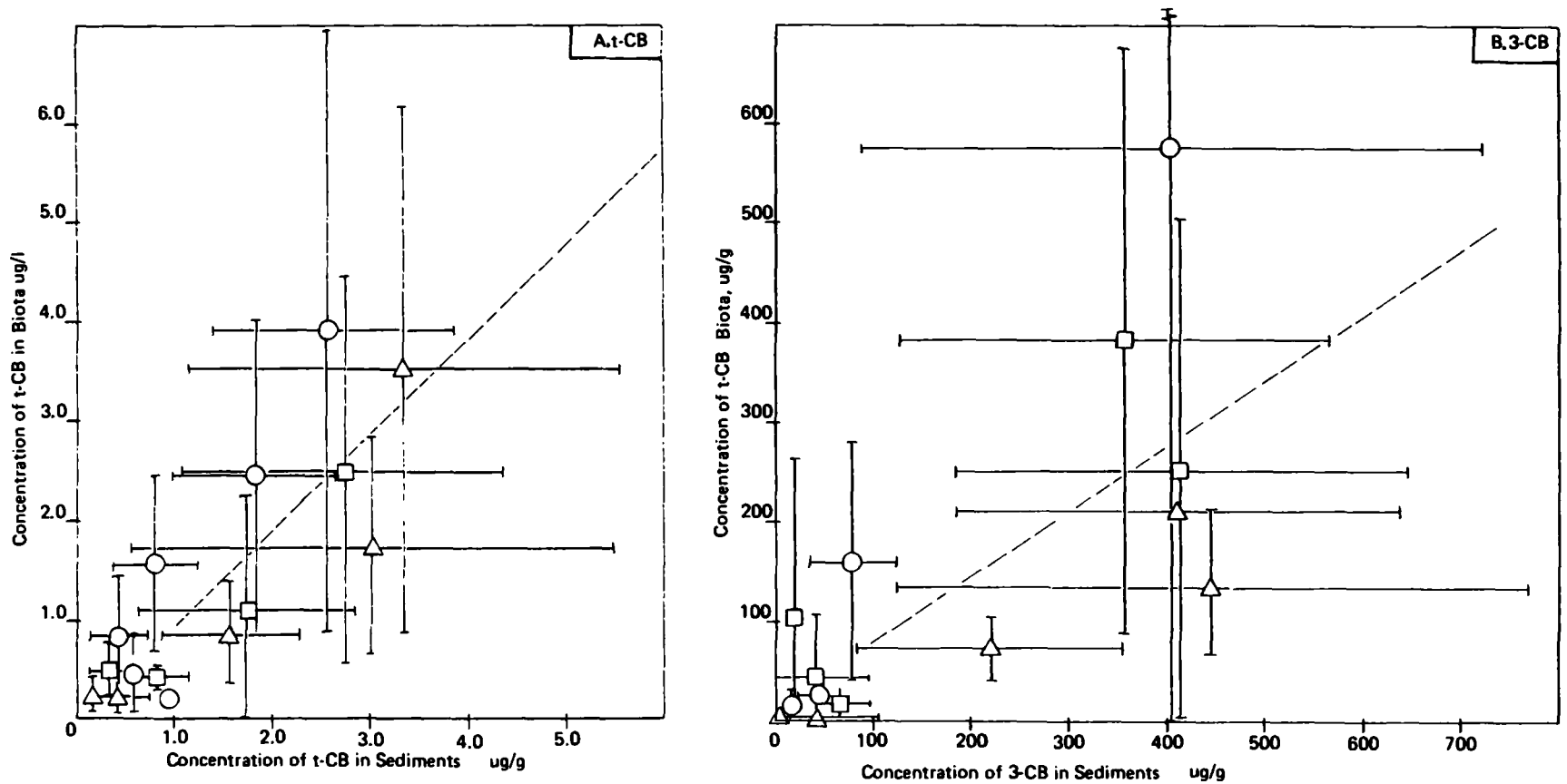

Figure 72. Mean Concentration in the Benthic Macrofauna versus the Mean Concentration in the Surface Sediments from each Sampling Station for a) t-CB and b) 3-CB. Vertical and horizontal lines represent the limits of one standard deviation for the biota and sediments, respectively. Dotted line represents the linear regression evaluation for all data. Data from Cruise 2, May 1979, ○ ; Cruise 3, October 1979, △ ; Cruise 4, May 1980, □

Overall, the data indicate a positive correlation between the PCB concentrations observed in the benthic macrofauna and the levels in the sediments from corresponding stations. Linear regression applied to the data from all three cruises (resulting equations plotted in Figure 72) yielded overall correlation coefficients ( $r$ ) of 0.840 and 0.747 for t-CB and 3-CB concentrations, respectively. In addition, the averaged t-CB concentrations in the organisms were very similar to the levels in the corresponding sediments (from the correlation equation, t-CB in the biota = 0.98 times the levels in the sediments), while the 3-CB concentrations in the biota were generally lower than those observed in the sediments (ratio from correlation was 0.64).

The high variability among the PCB concentrations at each station for both the biota and the sediments precluded statistical verification of these trends. In part, this variability resulted from the differences in the organisms analyzed from each station. In addition, the high spatial variability in the PCB concentrations in the sediments potentially provided a wide range of substrate-exposure levels at each station. Therefore, the levels in the biota may, in fact, have corresponded very well to the sediment levels, but this correspondence cannot be established from the pooled samples.

#### Differences among taxa

The concentrations of t-CB observed in the different taxa are plotted in Figure 73 versus the concentrations in the sediments from the corresponding sites. The plots for the different species have been ordered according to their feeding strategy, i.e., deposit feeders: *Capitellidae* spp., *Laonice cirrata*, shrimp spp., and bivalves; and carnivores: *Glycera capitata*, *Glycera americana*, and *Goniada brunnea*.

In addition, the plots include (dashed lines) an indication of the amount of the PCBs observed in the organisms which may have been contributed by sediments which were not flushed or otherwise separated from the samples during preparation. The estimates were based on the mean ash weight as a percentage of dry weight of the organisms and assume that the entire ash weight was composed of sediment of the same concentration of PCBs as observed at the site. Thus, the estimates were probably maximum values since, for at least some of the organisms, other

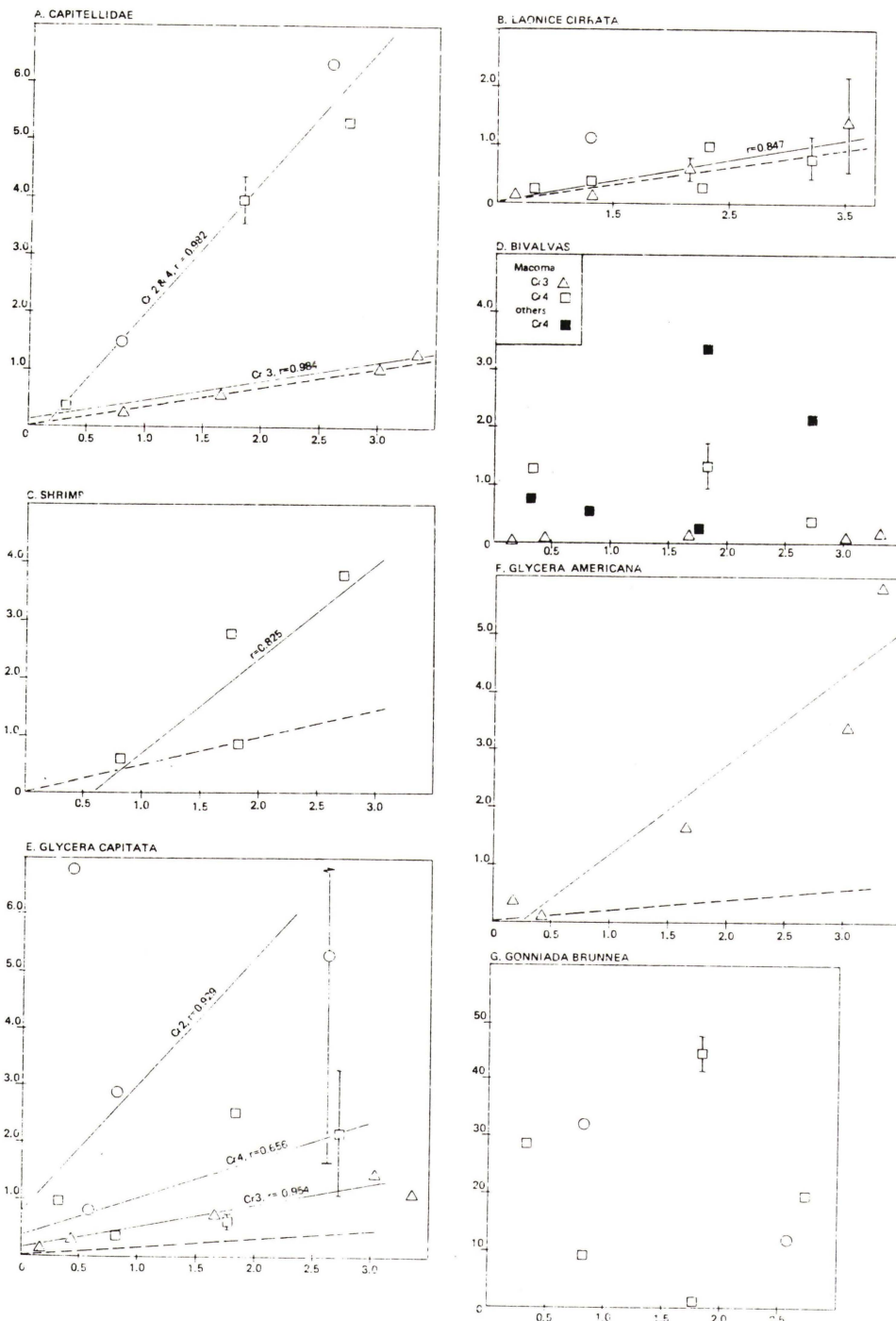

Figure 73. Plots of the Concentrations of t-CB Observed in the Individual Benthic Macrofauna Taxa Versus the Average t-CB Concentration in the Sediments from the Same Sampling Site. Solid lines depict linear regression correlations for the individual data sets. Dashed lines indicate estimated t-CB content of the biota resulting from sediments included in samples (see text for discussion). Data from Cruise 2,  $\circ$  ; Cruise 3,  $\triangle$  ; and Cruise 4,  $\square$  . a) Capitellidae, b) Laonice cirrata, c) Shrimp, d) Bivalves, e) Glycera capitata, f) Glycera americana, and g) Goniada brunnea



components (e.g., the mineralized exoskeleton of the shrimp), also contributed to the ash weight.

An examination of the plots in Figure 73 indicates that few, if any, clear generalizations can be drawn from these data. When the data were examined on a per cruise basis, the majority of the organisms exhibited reasonably strong linear correlations between the levels in the organisms and the concentrations in the corresponding sediments. The regression lines for those taxa which exhibited reasonably strong correlations have been plotted in Figure 73 and the equations are summarized in Table 34. It can be seen that the PCB concentrations in the taxa varied considerably in comparison to the levels in the sediments. Laonice cirrata, while exhibiting strong correlation with the corresponding sediments, had PCB concentrations which could have resulted from the inclusion of contaminated sediments and would not require the accumulation of any PCB residues within the tissue. At the other end of the range appeared to be Goniada brunnea, which did not show any correlation with the concentrations in the site sediments, but at the same time had mean body burdens of PCBs which were approximately 10 times greater than the sediments and much higher than the accumulation exhibited by the other taxa. Most of the other taxa fell between these extremes and exhibited accumulations to concentrations approximately one to two times the levels observed in the sediments during cruises 2 and 4; both the Capitellidae and Glycera capitata exhibited lower levels of PCBs during the October cruise. The concentrations of PCBs measured in the bivalve samples did not exhibit any correlation with the concentration in the corresponding sediments and were also relatively low compared to the concentrations in the other taxa. The bivalve data, however, probably reflect a high degree of analytical uncertainty due to the additional handling and sample preparation.

No ready explanation is available to explain the differences in the PCB concentrations observed among the taxa, although it must be cautioned that the limited data and lack of replication of the samples resulted in a high degree of uncertainty associated with these trends. At the same time, some of the differences, for example the large uptake of PCBs by G. brunnea and the temporal changes between the May and October cruises

TABLE 34. LINEAR REGRESSION EQUATIONS RELATING THE t-CB CONCENTRATIONS OBSERVED IN THE BIOTA TO THE MEAN CONCENTRATIONS OF THE CORRESPONDING SEDIMENTS AT EACH STATION

$$\text{Equation: } [t\text{-CB}]_{\text{Biota}} = b[t\text{-CB}]_{\text{Sediment}} + a$$

<u>Taxa</u>	<u>b</u>	<u>a</u>	<u>Correlation Coefficient (r)</u>
<u>Capitellidae spp.</u>			
Cruise 3 (4) <sup>a</sup>	0.33	+118	0.984
Cruise 4 (3)	2.09	-174	0.994
Cruises 2 and 4 (5)	2.13	-319	0.982
<u>Laonice cirrata</u>			
Cruise 3 (4)	0.45	-32	0.988
Cruise 4 (5)	0.22	+177	0.636
Cruises 3 and 4 (9)	0.35	+36	0.847
<u>Shrimp spp.</u>			
Cruise 4 (4)	1.65	-982	0.825
<u>Glycera capitata</u>			
Cruise 2 (4)	0.66	+3215	0.252
Cruise 2 (3)	1.89	+487	0.929
Cruise 3 (5)	0.36	+153	0.954
Cruise 4 (5)	0.67	+333	0.656
<u>Glycera americana</u>			
Cruise 3 (5)	1.55	-375	0.945
<u>Goniada brunnea</u>			
Cruise 4 (5)	-0.06	+20791	0.003
Cruises 2 and 4 (7)	-3.40	+26361	0.212
<u>Macoma spp.</u>			
Cruise 3 (5)	0.021	+50.6	0.555
Cruise 4 (3)	-0.33	+1534	0.891
<u>Other Bivalves spp.</u>			
Cruise 4 (5)	0.71	+351	0.511

<sup>a</sup> Numbers in parentheses indicates numbers of samples constituting the mean.

in the Capitellidae, were great enough that they appear to represent real differences and not simply analytical imprecision.

Insufficient data were available on physiological factors (e.g., percent lipid), feeding mode differences, and other ecological factors to explain the differences in the PCB concentrations among the taxa. Temporal changes in the PCB concentrations among the cruises corresponded to the changes in the PCB concentrations observed in the overlying water. Since the organisms were purged in site water prior to freezing for storage, it is possible that exposure and adjustment to the concentrations of PCBs in the water occurred during this sample preparation step.

#### Summary of PCB uptake studies

While there was considerable variability in the PCB concentrations among the taxa examined, overall, the data argued for increased concentration in the benthic organisms in direct relation to the concentrations in the ambient sediments. As a result, the recolonization of the disposal site may offer a direct link for transfer of the high PCB residues from the sediments to the aquatic food web. It is well known that many of the taxa observed on the disposal site are food for a variety of demersal fish and other organisms. At the same time, the importance of this mode of transfer of PCBs within the overall ecosystem is difficult to assess. It would be difficult to argue that the disposal site organisms would constitute more than a small portion of the diet of most predators within Elliott Bay. In addition, the current state of research has not, in fact, demonstrated that consumption of contaminated food within marine organisms leads to the comparable contamination of the predator. In fact, a number of studies have argued that other modes of contamination, particularly direct uptake from the ambient environment, are more important than feeding. It should be noted that, in comparison with the amount of PCB bound to sediments at the site, the amount which appears to be available for transfer through feeding is inconsequential. Finally, the effects of this transfer within the marine organisms are also difficult to assess; although based on the results of the biological study, it should be noted that even the higher

levels observed in some of the benthic infauna did not appear to be inducing any negative effects.

At the same time, it should be noted that the stability of the PCB residues within the dredged material deposit, as noted earlier, indicates that PCB contamination of the infauna and thus the transfer within the wider food web of Elliott Bay and Puget Sound may continue for a long period of time. Whether or not any long-term impacts would accompany this transfer is unknown.

## PART VIII: SUMMARY AND CONCLUSIONS

The results of this study clearly documented that the dredged material has been stable, both physically and chemically, at the deep-water site in Elliott Bay since its initial disposal in 1976. Any changes in the physical contours, the sediment texture, and/or the concentration of the refractory chemical constituents, e.g., PCBs, TOC, and O&G, have been so limited as to be below the threshold of detection for the methods used in this study.

The limited physical changes observed were consistent with the results of the current meter studies, which confirmed previous estimates that the currents in the deep water never attained speeds great enough to significantly resuspend the dredged material. In addition, transmissometer records and bottom photographs indicated that very low levels of suspended sediments were present in the deep water. This observation was consistent with the apparent lack of sedimentation and burial of the dredged material deposit.

From the biological standpoint, long-term detrimental impacts on the benthic macrofaunal community were not observed. If any effect could be designated, it would be that the dredged material provides a slightly better habitat than the surrounding sediments, as indicated by greater abundances and biomasses of many of the dominant taxa. In particular, no toxic response to the PCBs associated with the dredged material was observed, even when the data from the sensitive organisms such as the crustaceans were examined. Further, an apparent sprat-fall (settling to the bottom of young, previously planktonic organisms) of the common bivalve, Macoma carlottensis, occurred during the study with equal success both on and off the disposal site.

The only factor which poses a potential long-term hazard associated with the site is the fact that the PCBs (and possibly other toxic anthropogenic organic compounds) appeared to be accumulated in the resident macrofauna to greater levels at the disposal site in direct proportion to the levels in the ambient sediments. Since the high PCB

concentrations available to these biota at the site do not appear to be diminishing at an appreciable rate through either physical processes, e.g., burial or diffusion, or chemical/biochemical reactions, the contamination of the biota can be expected to continue for some time. While, as noted above, this does not appear to be directly affecting the resident macrofauna, predation of the contaminated organisms may provide a mode of transport of the PCBs to the higher members of the food web.

At the time, the overall threat to the food web organisms is probably minimal considering the depth of the dredged material deposit, its small spatial extent in relation to the areas of similar habitat, and the mobility of most predators, e.g., demersal fish.

As a result of this study, it can be concluded that most, if not all, major changes and impacts of the disposal operation have occurred, that the mound is now physically and chemically stable, and that only minimal long-term harmful effects to the biota have resulted from the disposal, with no direct toxic response apparent.

## REFERENCES

- Armstrong, F. A. J., C. R. Stearns, and J. D. H. Strickland. 1967. The measurement of upwelling and subsequent biological processes by means of the Technicon Autoanalyzer and associated equipment. *Deep-Sea Res.* 14:381-389.
- Banse, K., and K. Hobson. 1968. Benthic polychaetes from Puget Sound, Washington, with remarks on four other species. *Proc. U.S. Nat. Mus.* 125. No. 3667 p1-53.
- Banse, K., and K. Hobson. 1974. Benthic errantiate polychaetes of British Columbia and Washington. *Bulletin of the Fisheries Research Board of Canada.* No. 185. 111 pp.
- Bingham, C. R. 1978. Aquatic disposal field investigations, Duwamish Waterway Disposal Site, Puget Sound, Washington; Appendix G: Benthic community structural changes resulting from dredged material disposal, Elliott Bay disposal site. Technical Report D-77-24. U.S. Army Engineer Waterways Experiment Station, Vicksburg, Miss.
- Boesch, D. F. 1973. Classification and community structure of macrobenthos in the Hampton Roads area, Virginia. *Mar. Biol.* 21:226-244.
- Boesch, D. F. 1977. Application of numerical classification in Ecological investigations of water pollution. Report No. EPA-600/3-77-033, U.S. EPA, Corvallis Environmental Research Laboratory, Corvallis, Oregon.
- Carritt, D. E., and J. H. Carpenter. 1966. Modification of the Winkler method for dissolved oxygen in seawater; a comparison and evaluation. *J. Mar. Res.*, 24:286-318.
- Cliff, A. D., and J. K. Ord. 1973. *Spatial autocorrelation.* Pion Limited, London. 178 pp.
- Cline, J. D. 1969. Spectrometric determination of hydrogen sulfide in natural waters. *Limnol. Oceanogr.*, 14:454-458.
- Coan, L. 1971. Northwest American Teliimidae. Volume 14. July, 1971.
- Collias, E.E. 1976. Nutrient observations. In A.C. Duxbury (Ed.), *Puget Sound Studies: Interim Reports for the Municipality of Metropolitan Seattle.* pp 27-43.

- Dexter, R.N. 1976. Ph.D. Dissertation. Department of Oceanography, University of Washington, Seattle. 186 pp and appendices.
- Dexter, R.N., and S.P. Pavlou. 1978. Distribution of stable organic molecules in the marine environment: physical/chemical aspects. Chlorinated hydrocarbons. *Mar. Chem.* 7:67-84.
- Dexter, R.N., D.E. Anderson, E.A. Quinlan, L.S. Goldstein, R.M. Strickland, R.M. Kocan, M. Landolt, S.P. Pavlou, and J.R. Clayton. 1981. A summary of Knowledge of Puget Sound. NOAA/Technical Memorandum OMPA-13, National Oceanic and Atmospheric Administration, Boulder, Colorado. 435 pp.
- Fauchald, K., and P. Jumars. 1979. The diet of worms: a study of polychaete feeding guilds. *Oceanogr. Mar. Biol. Ann. Rev.* 17:193-284.
- Folk, R. L. 1964. Petrology of sedimentary rocks. Hemphills, Austin, Texas.
- Griffith, L. M. 1967. The Intertidal Univalves of British Columbia. Handbook No. 26, British Columbia Provincial Museum. 101 pp.
- Harman, R. A. and J. C. Serwold. 1978. Aquatic disposal field investigations, Duwamish Waterway Disposal Site, Puget Sound, Washington; Appendix F: Recolonization of Benthic Macrofauna over a Deep-water Disposal Site. Technical Report D-77-24. U.S. Army Engineer Waterways Experiment Station, Vicksburg, Miss. 454 pp.
- Hartman, O. 1968. Atlas of the errantiate polychaetous annelids from California. Allan Hancock Foundation. University of Southern California, 828 pp.
- Hartman, O. 1969. Atlas of the sedentariate polychaetous annelids for California. Allan Hancock Foundation. University of Southern California, 812 pp.
- Hobson, K., and K. Banse. Benthic sedentariate polychaetes of British Columbia and Washington. In prep.
- Hollander, M., and D. A. Wolfe. 1973. Nonparametric statistical methods. John Wiley & Sons. New York. 503 pp.
- Hom, W. 1979. Masters Thesis, Department of Oceanography, University of Washington, Seattle.
- Krumbein, W. C., and Pettijohn, F. J. 1938. Manual of sedimentary petrology. Appleton-Century-Crofts, New York.



- Lie, U. 1968. A quantitative study of benthic infauna in Puget Sound, Washington, USA, in 1963-1964. *Fisk Dir. Skr. Ser. Havunders.* 14: p. 229-556.
- Lie, U. 1974. Distribution and structure of benthic assemblages in Puget Sound, Washington. *Mar. Biol.* 26:203-223.
- Malins, D.C., B. McCain, D.W. Brown, A.K. Sparks, and H.O. Hodgins. 1980. Chemical contaminants and biological abnormalities in central and southern Puget Sound. NOAA Technical Memorandum OMPA-2, National Oceanic and Atmospheric Administration, Boulder, Colorado. 186 pp and appendices.
- McClellan, P. M. 1954. An Area and Volume Study of Puget Sound, Washington. Technical Report No. 21, Washington. Department of Oceanography, University of Washington, Seattle, Washington.
- Murphy, J., and J. P. Riley, 1962. A modified single solution method for the determination of phosphate in natural waters. *Anal. Chim. Acta*, 27:31-36.
- Murphy, P.G. 1972. Sulfuric acid for the cleanup of animal tissue for analysis of acid stable chlorinated hydrocarbon residues. *J. Assoc. Off. Anal. Chem.* 55:1360-1363.
- Oldroyd, S. 1924. Marine shells of Puget Sound and vicinity. Publication Puget Sound Biological Station. Vol. 4 268 pp.
- Paquette, R. G. 1958. A modification of the Wenner-Smith-Soule Salinity Bridge for the determination of salinity of sea water. Technical Report No. 61, Department of Oceanography, University of Washington, Seattle.
- Pavlou S. P., and R. N. Dexter. 1979. Distribution of Polychlorinated biphenyls (PCB) in estuarine ecosystems. Testing the concept of equilibrium partitioning in the marine environment. *Environ. Sci. Technol.*, 13:65-71.
- Pavlou, S. P., R. N. Dexter, W. Hom, and K. A. Kroglund. 1977. Polychlorinated biphenyls (PCB) in Puget Sound. Baseline data and methodology. Special Report No. 74, Department of Oceanography, University of Washington, Seattle, 252 pp.

- Pavlou, S.P., R.N. Dexter, W. Hom, A. J. Hafferty, and K.A. Kroglund. 1978. Aquatic disposal field investigations, Duwamish Waterway disposal site, Puget Sound, Washington; Appendix E: Release and distribution of polychlorinated biphenyls induced by open-water dredge disposal activities. Technical Report D-77-24, U.S. Army Engineer Waterways Experiment Station, Vicksburg, Mississippi. 96 pp and 5 appendices.
- Quayle, D. B. 1974. The intertidal bivalves of British Columbia. Handbook No. 17, British Columbia Provincial Museum. 104 pp.
- Rice, T. 1973. Marine shells of the Pacific Coast. Erco, Inc. 102 pp.
- SAS Institute Inc. 1979. SAS User's Guide, 1979 Edition. Raleigh, North Carolina.
- Sokal, R.R., and F.J. Rohlf. 1969. Biometry. W.H. Freeman and Company, San Francisco. 776 pp.
- Steel, R. G. D., and J. H. Torrie. 1960. Principles and procedures of statistics. McGraw-Hill Book Company, Inc. 481 pp.
- Stephenson, W., W. T. Williams, and G. N. Lance. 1970. The macrobenthos of Moreton Bay. Ecol. Monogr. 40:459-494.
- Stephenson, W., W. T. Williams, and S. D. Cook. 1972. Computer analyses of Petersen's original data on bottom communities. Ecol. Monogr. 42:387-415.
- Stephenson, W., W. T. Williams, and S. D. Cook. 1974. The benthic fauna of soft bottoms, Southern Moreton Bay. Mem. Qd. Mus. 17:73-123.
- Strickland, J. D. H. and Parsons, T. R. 1968. A practical handbook of seawater analysis. Fisheries Research Board of Canada, Bulletin 167, Ottawa.
- Tatem, H. E., and J. H. Johnson. 1978. Aquatic Disposal Field Investigations, Duwamish Waterway Disposal Site, Puget Sound Washington. Evaluative summary. Technical Report D-77-24. U.S. Army Engineer Waterways Experiment Station, Vicksburg, Miss. 77 pp.
- Thompson, J. R., Jr., Ed. 1977. Analysis of pesticide residues in human and environmental samples. Primate and Pesticide Laboratory, U.S. Environmental Protection Agency, Perrine, Florida.

- U. S. Department of Health, Education, and Welfare, Food and Drug Administration. 1977. Pesticide Analytical Manual. Food and Drug Administration, Office of the Associate Commissioner for Compliance, Rockville, Maryland.
- U. S. Environmental Protection Agency. 1974. Puget Sound 305-A Report. Report No. EPA 910/7-74-001. U. S. EPA Region X, Surveillance and Analytical Division, Seattle, Washington.
- Williams, W. T., and W. Stephenson. 1973. The analysis of three-dimensional data (sites x species x times) in marine ecology. J. Exp. Mar. Biol. Ecol. 11:207-227.
- Wishart, D. 1975. Clustan 1C user manual. Computer Centre, University College London, London, England.

