

TA7
W34
no.D-74-2
c.3

ORLOP-AN

20

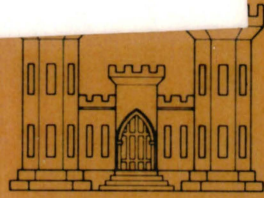

DREDGED MATERIAL RESEARCH PROGRAM

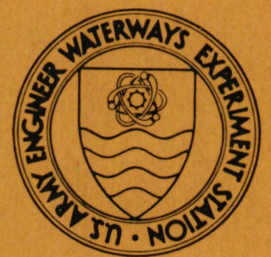

TECHNICAL REPORT D-74-2

PRACTICES AND PROBLEMS IN THE CONFINEMENT OF DREDGED MATERIAL IN CORPS OF ENGINEERS PROJECTS

by

W. L. Murphy and T. W. Zeigler

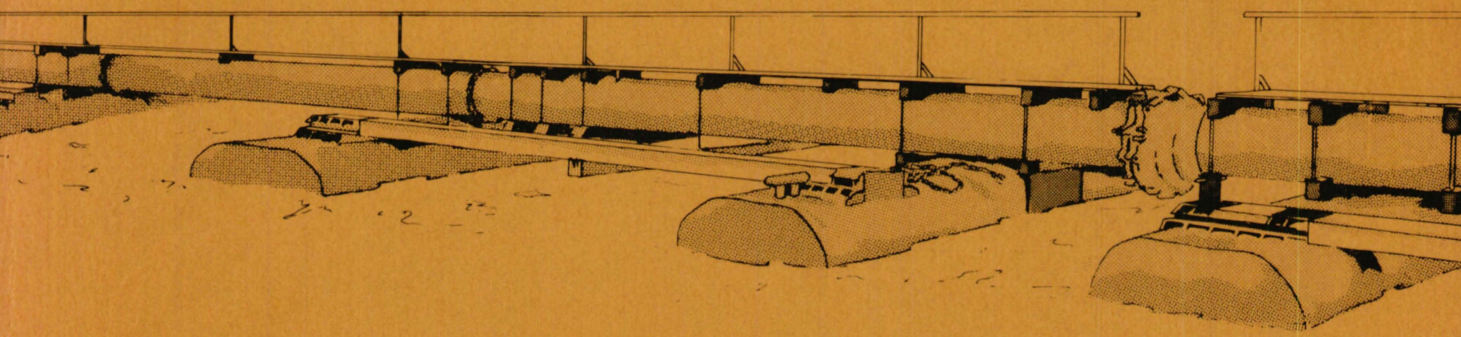

May 1974

Sponsored by Office of Dredged Material Research

Conducted by U. S. Army Engineer Waterways Experiment Station
Soils and Pavements Laboratory
Vicksburg, Mississippi

US-CE-C

PROPERTY OF THE UNITED STATES GOVERNMENT

Destroy this report when no longer needed. Do not return
it to the originator.

The findings in this report are not to be construed as an official
Department of the Army position unless so designated
by other authorized documents.

U. S. ARMY ENGINEER DISTRICT, LOUISVILLE
TECHNICAL LIBRARY
P. O. BOX 59
LOUISVILLE, KENTUCKY 40201

USACEWES



3 5925 00287 4854



DEPARTMENT OF THE ARMY
WATERWAYS EXPERIMENT STATION, CORPS OF ENGINEERS
P. O. BOX 631
VICKSBURG, MISSISSIPPI 39180

IN REPLY REFER TO: WESVS

23 May 1974

SUBJECT: Transmittal of Technical Report D-74-2

TO: All Report Recipients

1. The technical report transmitted herewith represents the results of an intensive and extensive information-gathering and assessing effort conducted during the problem definition and assessment and research plan formulation phases (Phases I and II) of the Corps' Dredged Material Research Program (DMRP).
2. Rather early in the program, it became apparent that confining both polluted and nonpolluted dredged material on land or in shallow water behind retaining dikes was a rapidly expanding activity for which there was and still is little precedent or factual knowledge. Nearly every Corps District office was experiencing situations in which open-water disposal or unconfined land disposal was being abandoned, largely for reasons of reducing actual or feared adverse environmental impacts. The outlook was for an increase in such activity. Through a lack of case histories and practical experience, the Districts were forced to construct and operate confined disposal areas on a trial-and-error basis.
3. The information gathered and presented herewith is intended to serve three purposes:
 - a. To set the framework around which to plan and implement a program of research to provide answers to the many questions facing the District offices. Formulation and implementation of Task 2C (Containment Area Operation Research) of the DMRP are a direct result of this problem assessment.
 - b. To present to the Corps District offices a broad overview of the problem, a perspective as to the extent and severity of specific disposal site problems, and dissemination of the experience-based information of one District to all other Districts.
 - c. To assemble in one document a basic introduction to and general discussion of the overall issue as a basic reference for future program contractors and persons in other agencies involved with dredged material disposal. To this end, the inclosed report is a unique contribution to the literature.

WESVS

23 May 1974

SUBJECT: Transmittal of Technical Report D-74-2

4. While this report discusses such topics as disposal area size determination; effluent sluice design, construction, and operation; facility operation and environmental control; and dredged material fill consolidation and stabilization, it emphasizes strongly the most critical aspect of dredged material confinement, i.e., retaining dike design, construction, and stability. In general, the technical state-of-the-art was found adequate to overcome many of the problems being experienced; however, application of the technology is often deterred or prevented by factors such as funding limitations, improper designation of responsibilities, inadequate inspection provisions, and various policy and institutional matters.
5. As a partial result of the effort reported herein, considerable research is already in progress under the DMRP to provide answers or alternatives to both technical and nontechnical issues, and additional research is in the planning and evaluation stages.

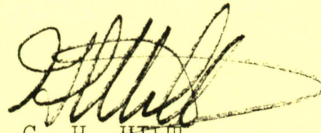

G. H. HILT
Colonel, Corps of Engineers
Director

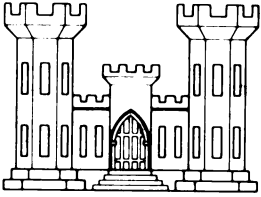

DREDGED MATERIAL RESEARCH PROGRAM

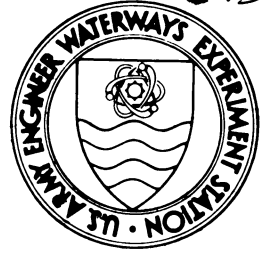

TECHNICAL REPORT D-74-2

PRACTICES AND PROBLEMS IN THE CONFINEMENT OF DREDGED MATERIAL IN CORPS OF ENGINEERS PROJECTS

by

W. L. Murphy and T. W. Zeigler

May 1974

Sponsored by **Office of Dredged Material Research**

Conducted by **U. S. Army Engineer Waterways Experiment Station**
Soils and Pavements Laboratory
Vicksburg, Mississippi

ARMY-MRC VICKSBURG, MISS.

APPROVED FOR PUBLIC RELEASE; DISTRIBUTION UNLIMITED

TA
7
.W34
D-74- 2

P981

FOREWORD

This report presents the results of an investigation of problems and practices involving the Corps of Engineers confined dredged material disposal activities. This investigation was conducted as part of the Corps of Engineers Dredged Material Research Program (DMRP). The DMRP is sponsored by the Office, Chief of Engineers (DAEN-CWO-M), and was formally authorized by letter, "Study Program for Disposal of Dredge Spoil," dated 27 December 1971.

The study was conducted during the period May 1972-August 1973 in the Office of Dredged Material Research (ODMR), U. S. Army Engineer Waterways Experiment Station (WES), by Messrs. W. L. Murphy and T. W. Zeigler of the Engineering Geology Division and the Rock Mechanics Division, respectively, Soils and Pavements Laboratory, WES. The study was conducted under the direction of Dr. R. T. Saucier, Assistant Chief, ODMR; Mr. R. L. Montgomery, Project Manager, Land Disposal and Equipment Project, ODMR; and Mr. C. C. Calhoun, Jr., Acting Project Manager, Land Disposal and Equipment Project, ODMR. The study was under the general supervision of Dr. John Harrison, Chief, ODMR, and Mr. M. B. Boyd, Technical Consultant, ODMR. The report was written by Messrs. Murphy and Zeigler.

The Directors of WES during the study and preparation of this report were BG E. D. Peixotto, CE, and COL G. H. Hilt, CE. Technical Director was Mr. F. R. Brown.

CONTENTS

	<u>Page</u>
FOREWORD	iii
CONVERSION FACTORS, BRITISH TO METRIC UNITS OF MEASUREMENT . . .	vii
SUMMARY.	ix
PART I: INTRODUCTION.	1
Background and Approach.	1
Purpose.	2
Scope.	2
PART II: STATUS OF CONFINED DREDGED MATERIAL DISPOSAL	3
Historical Background and Present Policy	3
Land Acquisition Difficulties.	7
Alternatives to Lowland Dredged Material Disposal.	9
Long-Range Planning.	10
Multiple Use of Disposal Areas	16
PART III: CONTAINMENT AREA DESIGN AND OPERATION	24
Preliminary Site Considerations.	24
Disposal Methods	31
Effluent Sluicing Methods.	36
Containment Facility Operation	45
Odor Control	59
Mosquito Control	61
Disposal Area Effluent Requirements.	62
PART IV: RETAINING DIKE DESIGN, CONSTRUCTION, AND STABILITY . . .	65
Description of Retaining Dikes	66
Retaining Dike Design.	82
Retaining Dike Construction.	93
Retaining Dike Performance	106
PART V: CONCLUSIONS AND RECOMMENDATIONS	127
Acquisition of Disposal Sites.	125
Long-Range Planning.	126
Containment Facility Design and Operation.	126
Diking Methods	127
Dike Design.	128

Dike Construction.	129
Dike Stability	130
LITERATURE CITED	133

TABLES 1-3

APPENDIX A: LAND-BASED EARTH DIKES DESIGNED AND CONSTRUCTED UNDER DREDGING CONTRACTS
APPENDIX B: LAND-BASED EARTH DIKES DESIGNED BY THE CE AND CONSTRUCTED UNDER DREDGING CONTRACTS
APPENDIX C: LAND-BASED EARTH DIKES DESIGNED BY THE CE AND CONSTRUCTED UNDER SEPARATE CONTRACTS
APPENDIX D: IN-WATER EARTH- AND ROCK-FILL DIKES DESIGNED BY THE CE AND CONSTRUCTED UNDER SEPARATE CONTRACTS

CONVERSION FACTORS, BRITISH TO METRIC UNITS OF MEASUREMENT

British units of measurement used in this report can be converted to metric units as follows:

<u>Multiply</u>	<u>By</u>	<u>To Obtain</u>
mils	0.0254	millimeters
inches	2.54	centimeters
feet	0.3048	meters
miles (U. S. statute)	1.609344	kilometers
square feet	0.092903	square meters
cubic yards	0.7645548	cubic meters
acres	0.4046856	hectares
feet per second	0.3048	meters per second
cubic yards per hour	0.7645548	cubic meters per hour
pounds per square inch	0.6894757	newtons per square centimeter
cubic feet per second	0.02831685	cubic meters per second
gallons per minute	0.003785	cubic meters per minute
pounds	0.4535924	kilograms
tons (2000 lb)	907.1847	kilograms

SUMMARY

Confined dredged material disposal problems and practices were discussed with representatives of 17 Corps of Engineers (CE) District offices to obtain a data base for subsequent related research efforts to be implemented by the Dredged Material Research Program at the U. S. Army Engineer Waterways Experiment Station and to disseminate the data to CE Districts and others.

Although confined disposal of dredged material when compared with unconfined disposal is secondary in terms of quantity, it is increasing because of recent requirements for containment of dredged material that is considered polluted and the resulting curtailment of much open water disposal. A diminishing supply of suitable disposal areas, caused by filling of existing sites and difficulties in acquiring sites because of environmental or cultural constraints, has become a major problem of CE Districts. Long-range planning by some CE Districts has suggested three solutions to this problem:

- a. Long-distance piping of dredged material to large disposal facilities.
- b. Diking of disposal areas in water.
- c. Possible acquisition of permanent disposal facility acreage by the Federal Government. Reuse of filled disposal facilities for agricultural, recreational, and industrial purposes, and for recycling of the dredged material itself is also being investigated by CE Districts and others.

Dredged material is most often conveyed to confined disposal facilities hydraulically; that is, by pipeline dredge or by pumpout of hopper dredges, temporary rehandling basins, or loaded scows. Mechanical filling of areas by dipper, bucket, and ladder dredges is less frequent and usually supplementary to hydraulic methods. Long-distance hydraulic pumping of dredged and similar materials has been shown to be feasible both by CE dredging experience and by nondredging industry-related applications. Size limitations on the material pumped, costs of equipment and personnel, and right-of-way acquisition difficulties are problems in the implementation of long-distance slurry transport.

There are few efficient, well-designed facilities for the containment of dredged material. Channelization of dredged material from the

discharge point to the sluice, the effects of wind, mounding and uneven distribution of dredged material, and retaining dike stability are common problems associated with containment facility operation. Present efforts in abating the above problems and in improving the efficiency of containment facilities consist primarily of the use of energy dissipating devices within the facility and the use of various sluice configurations. The sluices most commonly used are the drop inlet type, but siphons, outfall pipes, flumes, and filters are occasionally used. Odors and mosquitoes are sometimes associated with disposal operations and must be controlled.

Effluent quality standards are generally set by the State and are most often density and/or turbidity requirements. At the time of this study, Federal pollution standards regarding effluent quality did not exist. Guidance in the matter of disposal facility effluent requirements is needed by CE Districts.

Retaining dikes are primarily earth embankments constructed on lowland areas or nearshore islands. Several in-water containment facilities have been constructed, and in certain cases rockfill or slag has been used in dike construction. Retaining dike dimensions and composition vary considerably from District to District and within Districts. Dike characteristics are largely dependent on foundation conditions and available construction materials. However, these characteristics are also influenced by individual District policy regarding dike design and construction and available funding. The majority of retaining dikes are constructed as part of the dredging contract, although separate dike construction contracts are used in some instances. In the past, most Districts have left dike design and construction to the discretion of the dredging contractor. However, some Districts have taken a more active role in the control of design and construction because of damaging dike failures and encroachment on populated areas. Little or no information is available on the design of dikes constructed as a part of the dredging contract. CE design of retaining dikes is based primarily on past experiences. Thorough field and laboratory investigations and stability analyses are reserved only for special cases, such as containment facilities planned for long-range disposal and future development or facilities located adjacent to industrialized or populated areas.

Dike construction is made difficult by generally poor foundation conditions and the use of low-quality borrow materials. Foundations of soft organic deposits are common. Dike fill is commonly placed loose by dragline with no compaction and often consists of previously deposited fine-grained dredged material with high water content. Hydraulic pumping of materials has been used to establish wide dike sections for support on weak foundations. Semicompaction and stage construction of embankment fills and foundation displacement techniques have been applied to retaining dike construction.

Retaining dikes often require continual maintenance. Failures have occurred largely because of poor foundation conditions and construction materials compounded by inadequate dike design, poor

construction practices, and minimal inspection of dikes during dredging operations. The effects of seepage are directly responsible for or contribute to the majority of retaining dike failures.

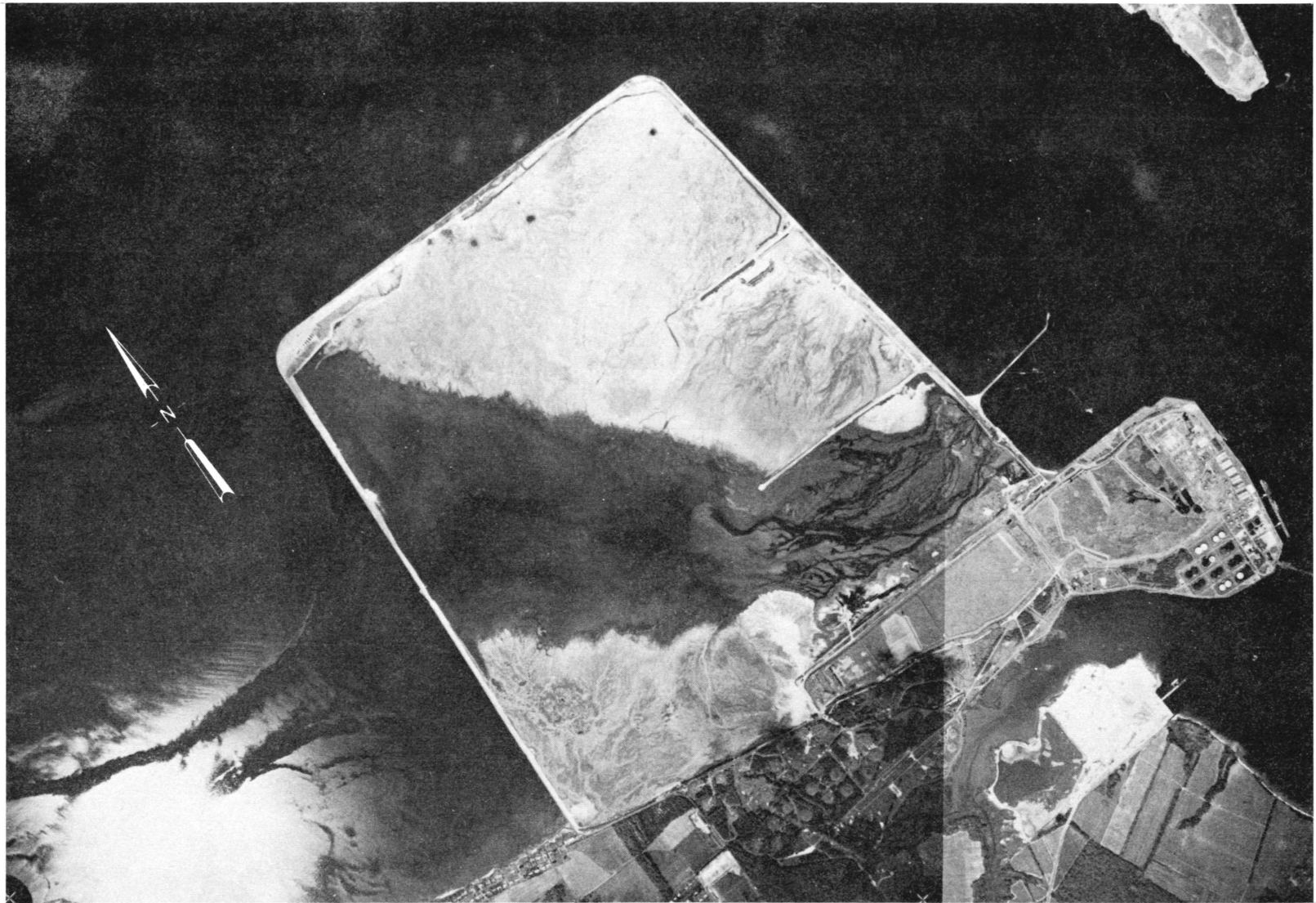

Infrared aerial photo of Craney Island dredged material containment facility, Norfolk, Virginia

PRACTICES AND PROBLEMS IN THE CONFINEMENT OF DREDGED
MATERIAL IN CORPS OF ENGINEERS PROJECTS

PART I: INTRODUCTION

Background and Approach

1. Land disposal of dredged material, both confined and unconfined, is discussed briefly in U. S. Army Engineer Waterways Experiment Station (WES) Technical Report H-72-8, "Disposal of Dredge Spoil, Problem Identification and Assessment and Research Program Development,"¹ dated November 1972. This report presents the more detailed findings of visits with 17 Corps of Engineers (CE) District offices during the period May-October 1972 to gather data specifically on the Districts' confined dredged material disposal operations. Locations of disposal sites and information pertaining to containment facility construction, disposal area operation, dike stability and similar problems, disposal area uses, and many related aspects were obtained for as many sites as possible. This information was obtained through discussions with key personnel, occasional visits to disposal sites, and examination of data from field investigations, contract drawings and specifications, and reports prepared by the Districts and other agencies.

2. A list of discussion points and desired data was made up before the first visit and subsequently modified as additional sources of information were discovered. Construction, Operations, and Engineering Divisions were the most frequently contacted staff elements. The Districts contacted employ a cross section of disposal practices both quantitatively (volume of dredged material confined) and qualitatively (problems, methods used, and geographic locations). They were the Galveston, New Orleans, Vicksburg, Mobile, Jacksonville, Savannah, Charleston, Wilmington, Norfolk, Philadelphia, New York, Buffalo, Detroit, Chicago, Sacramento, Portland, and Seattle Districts.

Purpose

3. The purpose of this report is to disseminate information to CE Districts and others on the current practices and resultant problems or efficiencies of confined dredged material disposal operations. This report will also serve as an introduction to and data base for subsequent research in dike design and construction, disposal area management, dredged material consolidation and stabilization, and wildlife habitat enhancement, which will be accomplished under the CE Dredged Material Research Program.

Scope

4. This report discusses only those disposal operations in which the dredged material is deposited within an area confined by natural or man-made barriers. The containment barrier may be an embankment or an open pit that will retain solids and pollutants and allow escape of less turbid and polluted water. The study dealt primarily with existing disposal sites for which pertinent data were available. Complete records of disposal area operations in most Districts are generally unavailable for two reasons. First, the dredging contractor is frequently responsible for construction, operation, and maintenance of the containment facilities, and procedures are not recorded for each contractor's work. Second, in the past, little attention has been paid to the disposal of dredged material other than attempts to keep it out of the channel from which it was dredged. Disposal areas have grown or deteriorated through the years as dredging needs dictated. This practice is changing with the advent of concerted efforts by various agencies to define and control adverse effects of man's activities on the environment.

PART II: STATUS OF CONFINED DREDGED
MATERIAL DISPOSAL

Historical Background and Present Policy

Background

5. Most dredged material confining efforts have occurred within the last 20 yr. Two CE Districts, Sacramento and Philadelphia, used confined disposal sites as early as the 1930's. Many unconfined disposal sites, particularly along the Gulf Coast, have evolved into confined areas through diking as a result of restrictions imposed by encroaching industrial and residential developments, to meet demands of environmental agencies for controlling the quality of discharges into water areas, and to prevent large-scale destruction of wildlife habitats. Fig. 1 shows the average annual disposition of dredged material by District for confined and unconfined disposal.

6. Pressures exerted by environmental awareness and action groups have culminated in criteria developed by the Environmental Protection Agency (EPA) for determining acceptability of dredged material for open water disposal. The criteria were circulated to CE offices in Engineering Circular EC 1165-2-97² in May 1971. Several criteria are listed for evaluation of the suitability of dredged material for disposal on a case by case basis, including volume of dredged material, time of year, method of disposal, and others. The dominant criteria listed, however, are "physical, chemical, and biological characteristics of the dredged material" for which pollution limits are set in percentage concentrations of various pollutants contained in the sediment being dredged. The criteria discussed above should not be confused with disposal area effluent quality requirements that are normally set by the State government or regional water quality control board. These requirements are usually density (in grams per liter above the ambient) or turbidity limits applied to the overflow at and near the sluice of a dredged material containment facility. Effluent requirements are discussed in Part III of this report.

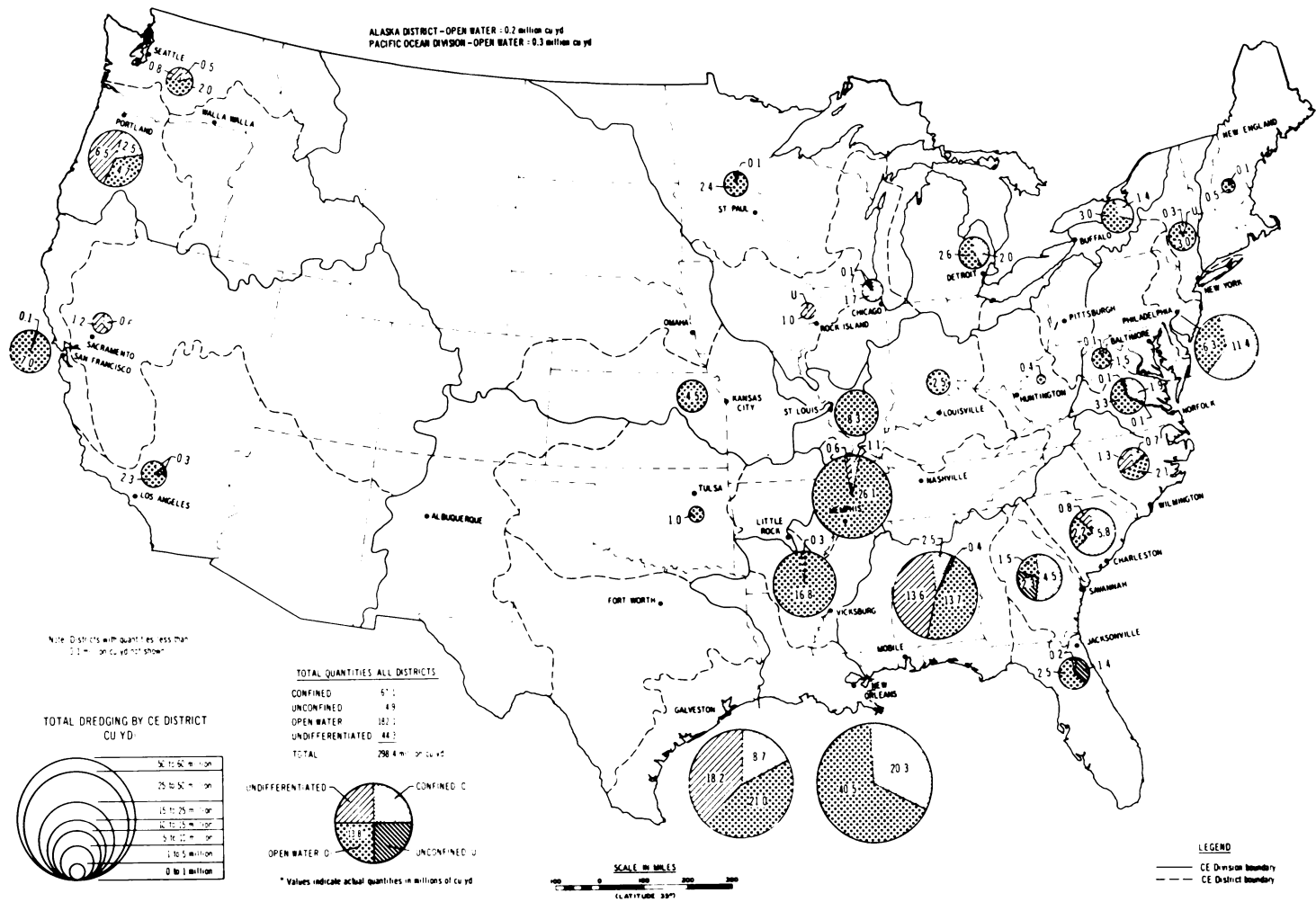

Fig. 1. Disposition of dredged material generated in maintenance dredging operations and average annual quantities of material disposed of by area and by District (from reference 1)

CE policy

7. CE policy regarding open water disposal of dredged material determined to be polluted according to the EPA criteria is stated in EC 1165-2-116³ as follows:

On those projects where open water disposal is the current practice, this practice shall continue, unless local interests provide suitable alternate confined areas at no cost to the government. Where no authority is available to the Corps of Engineers to provide retention facilities and local interests do not have the capability or means of providing such facilities and the state or local authorities disapprove of past disposal procedures, the Governor should be advised that the alternative is to suspend dredging operations and the effects thereof, and his view sought on action to be taken.

EC 1165-2-116 also suggests procedures to follow when alternate disposal methods are requested in lieu of open water disposal. It is not, however, a statement of the requirements of local interests. Local cooperation for a project is defined in the authorization act for a given project (see paragraph 8).

8. Cooperation of local interests. The cooperation required of the local interests or sponsor in confined disposal operations varies among Districts and projects and is stipulated in the congressional act authorizing the CE to carry out the work. Guarantees of meeting the requirements must be submitted to the District Engineer by the local interests before work on the project is begun. Often, the local interests or sponsor, which may be the county, the city, the port commission, the State, or other responsible body, must obtain the disposal area easements and rights-of-way and may be required to provide retaining dikes. The sponsor may elect to construct required dikes himself or pay the CE for the construction. Repair and maintenance of the disposal facilities usually are accomplished at CE expense. Rarely are repair and maintenance handled by the sponsor. In one situation, the CE was dissatisfied with the quality of work performed by the sponsor in construction of disposal facilities; consequently, the CE chose to use its own personnel and equipment on a cost reimbursable basis for the actual repairs and maintenance. Recent project acts have commonly

required local interests to supply suitable disposal areas and confinement facilities if they are needed. Many older project authorizations directed the CE to obtain disposal area easements and supply the containment facilities. The original project authorization (congressional act) must be consulted to determine responsibility and authority for acquisition of easements and construction of disposal facilities for a given project.

9. One west coast District has seen the sponsorships for a project jump from hand to hand as industries, which, as local interests, were required to supply disposal area easements, came and left. Under such circumstances, the District lost sponsorships for some projects. The District began to supply disposal areas in lieu of the sponsor and justified this action by stating that it was necessary to prevent reshoring of the channels by the excavated material. Furthermore, some sponsors who had formerly been required only to supply the land for upland disposal, but who have since been asked to dike the area to meet the requirements of confined disposal, have balked at the request. The effect is that the District has been forced into supplying the facilities or cancelling or postponing the dredging operation. These difficulties, coupled with a general increase in confined land disposal and a rapid depletion of available sites, have given rise to considerations of new policy. Included are considerations of giving authority to the CE to acquire and maintain disposal areas and containment facilities to provide long-range planning and expediency of maintenance dredging operations.

10. Great Lakes situation. The Districts in the Great Lakes area have been engaged for many years in the practice of disposing of dredged material in the open waters of the lakes. The Rivers and Harbors Act of 1970 (Public Law 91-611, Sec 123) provides for the retention within containment facilities of all polluted material dredged by the CE in the Great Lakes. The CE has been authorized to design and build containment facilities of sufficient capacity to hold 10 yr of dredgings. The project sponsor is required to provide 25 percent of the construction costs and meet certain other obligations. Reaction by the Districts

to this order has been an effort to provide well-designed facilities at several sites in the Great Lakes area for the 10-yr plan. To date, six of these facilities are under construction or in the design stage, and six have been completed and are being used.

Land Acquisition Difficulties

Perpetual and temporary easements

11. The increasing changeover to confined disposal has created what is probably the most common dredging-related problem among CE Districts--that of acquiring and retaining suitable disposal acreage. Acreage for disposal sites is most commonly obtained by perpetual or temporary easements. Agreements are reached between private landowners and either the local sponsor or, rarely, the CE, or between the CE and the local sponsor if public land is being offered. A few disposal areas are Federally owned; some are contractor owned and operated and are used for the disposal of dredged material from government contracts and other projects; and some are State owned. Perpetual easements nominally imply that the District will have use of the area as a disposal site for as long as needed or until the site is filled to capacity or to an agreed elevation. In practice, however, the landowner sometimes reclaims the area as soon as it attains sufficient elevation to make it valuable for development, even before the government easement has terminated. In some instances, the CE not only loses the easement but also is required to protect from damage by further filling all structures and developments subsequently placed on it. Most disposal sites are located in lowland areas of marginal real estate value, so practically any material introduced there that raises the elevation above tide range is usually welcomed by the landowner.

12. Loss of easements in perpetuity is usually due to the courts' judgment of what is reasonable consideration (compensation) for perpetual use of the land. Commonly, the only consideration granted in a disposal easement contract is the dredged material itself. In most cases, dredged material is not considered sufficient consideration.

Portions of temporary easements most commonly are lost through the landowner's enforcement of the contract clause that states that the user shall not damage the land or structures thereon. If the CE does not halt the building of improvements on the easement, by warning or the issuance of an injunction, it must then protect such improvements. The CE has the responsibility to enforce its right to the use of the land. The court will almost always rule against the CE if the right is not self-enforced. Two methods have been used to detect improvements in their early or planning stages. First, easements are patrolled by boat twice yearly to check for building activities. Second, clipping services supply a list of all building permits applied for in the areas of interest. Such permits are commonly filed with city or county planning departments. Once improvement attempts are discovered, a simple verbal warning to the landowner is usually all that is needed to halt further activities.

Disposal area loss by conservation

13. Containment facilities are sometimes constructed in shallow water. Deposition of dredged material within these sites often creates, in time, new land that serves as a sanctuary for migrating and indigenous wildlife. These man-made islands or land extensions are sometimes declared wildlife refuges in the interest of wildlife conservation and thereby protected from further disposal of dredged material.

Marshland restrictions

14. The acknowledged ecological importance of marshlands and adjacent estuarine areas and the increasing aesthetic value being placed on these areas have led to increasing difficulty in obtaining disposal easements therein. In one District, disposal on tideland has been halted completely; in some west coast Districts, special permits must be obtained from the State by the landowner or the lessee before operations can begin. Thousands of acres of potential disposal sites around one east coast port have been purchased and protected by nonresidents for use as wildlife sanctuaries. The result of these pressures and those created by expanding residential and industrial developments is

that the Districts will have to provide a selection of viable alternatives for confining disposal of dredged material. The problem will become more acute if open water disposal is eliminated completely.

Alternatives to Lowland Dredged Material Disposal

15. Three solutions to the problem of depletion of disposal sites were suggested in the discussions with CE personnel:

- a. Acquisition of upland sites, often entailing long-distance pumping of dredged material (see Part III).
- b. Diking in shallow and possibly deep water.
- c. Federal Government purchase of large tracts of land for permanent dredged material collection sites.

16. Shallow-water diking has been used with varied success. The chief objection to diking in shallow brackish or saltwater areas is the potential for damage to shrimp and oyster industries through the destruction of breeding grounds. On one project, a hydraulic-fill dike of blasted and dredged limestone was constructed for dredged material retention in shallow water away from the channel. The dikes had to be breached at intervals, however, to keep shrimp breeding grounds open, thus greatly decreasing the effectiveness of the containment facility. Where constraint is not so significant, however, shallow-water diking is a promising prospect; it has been used very successfully at Port Arthur, Texas, and Norfolk Harbor, Virginia, and is planned for some Great Lakes harbors. The Philadelphia District's "Long-Range Spoil Disposal Study"⁴ presents a very relevant discussion of design and construction of dredged material retention dikes in shallow waters and tidelands.

17. Federal Government purchase of sufficient disposal areas to meet the dredging needs for an extended period could alleviate some disposal area problems. For example, containment structures could be better designed and constructed, with funds provided specifically for that purpose; future dredging needs could be projected to allow provisions for expansion of the containment facilities when needed; and more

efficient and effective operation of the facilities, especially in retention of solids and pollutants, could be achieved. It is presently difficult, with short-term easements and occasional loss of easements, to secure disposal sites of sufficient size to afford proper retention time for adequate settling of suspended solids from the effluent. However, if the dredged material is of suitable quality, it can be used or sold for fill or aggregate or for other beneficial purposes. This allows recovery of some of the volume of the area and helps to reimburse the Government for some of the cost. A few disposal areas in Sacramento have been completely rejuvenated by removing the sandy dredged material for use in highway construction. Dredged material deposited in the Craney Island disposal facility, Norfolk Harbor, Virginia, has been sold occasionally.

18. Irrespective of policy or funding changes, research can continue to alleviate certain dredged material disposal problems. The New Orleans District's Environmental Resources Branch plans effluent monitoring programs and studies of the effects of confined disposal on plant and animal life in the marshes. Windom⁵ reported recently on the effects of dredged material deposition on salt marshes and on changes in the biota resulting from dredging operations in a section of the southeastern United States. Such studies can lead to identification of the true extent of damage to marshlands by disposal activities and assist in decisions on methods of using tidelands to minimize deleterious effects. Indiscriminate banning of all marshland disposal would be extremely detrimental to present and future dredging programs. Hopefully, research will preclude a total ban on marshland disposal and allow continued but efficient and environmentally compatible use of these vital lands.

Long-Range Planning

19. Disposal sites generally have been supplied as needed. The growing demand for confinement of dredged material, however, has prompted some CE Districts to provide, where possible, for containment facilities

adequate for projected long-range needs. The Philadelphia report⁴ concluded in the section on dike design and construction that:

As disposal areas are forced more into areas of poorer foundations by completion of more desirable areas, it becomes increasingly important to design dikes using long-range planning principles rather than relying on each contractor to satisfy only requirements for his contract.

Several Districts have prepared studies of projected disposal practices for major dredging projects.

Mobile Harbor

20. Mobile District is considering the acquisition of most of Blakely and Pinto Islands in the Mobile Harbor area for development of containment facilities sufficient for 30 to 40 yr of disposal. Existing, relatively small, isolated areas would be included in two massive sites, each ringed by a single dike (fig. 2). The dikes would extend across narrow portions of Mobile Bay where necessary and be riprapped in those reaches for protection.

Charleston Harbor

21. A report prepared by the Charleston District⁶ in 1966 discusses the life expectancies of the existing and proposed dredged material disposal areas as projected over a 60-yr period (1965-2024). The sites are compared on the basis of their capacities and the expected demands. Further investigations, authorized as part of a long-range disposal study, have centered on outlining and evaluating various alternatives in dredged material disposal for Charleston Harbor.⁷ The alternatives considered include:

- a. Removal of shoal material to permanent land disposal areas.
- b. Removal of shoal material to temporary rehandling basins and then to permanent land or sea disposal areas.
- c. Removal of shoal material to sea disposal areas by hopper dredge or by pipelines equipped with mechanical or electrical boosters. The techniques and equipment discussed in this report are based on those of the earlier Philadelphia study.⁴

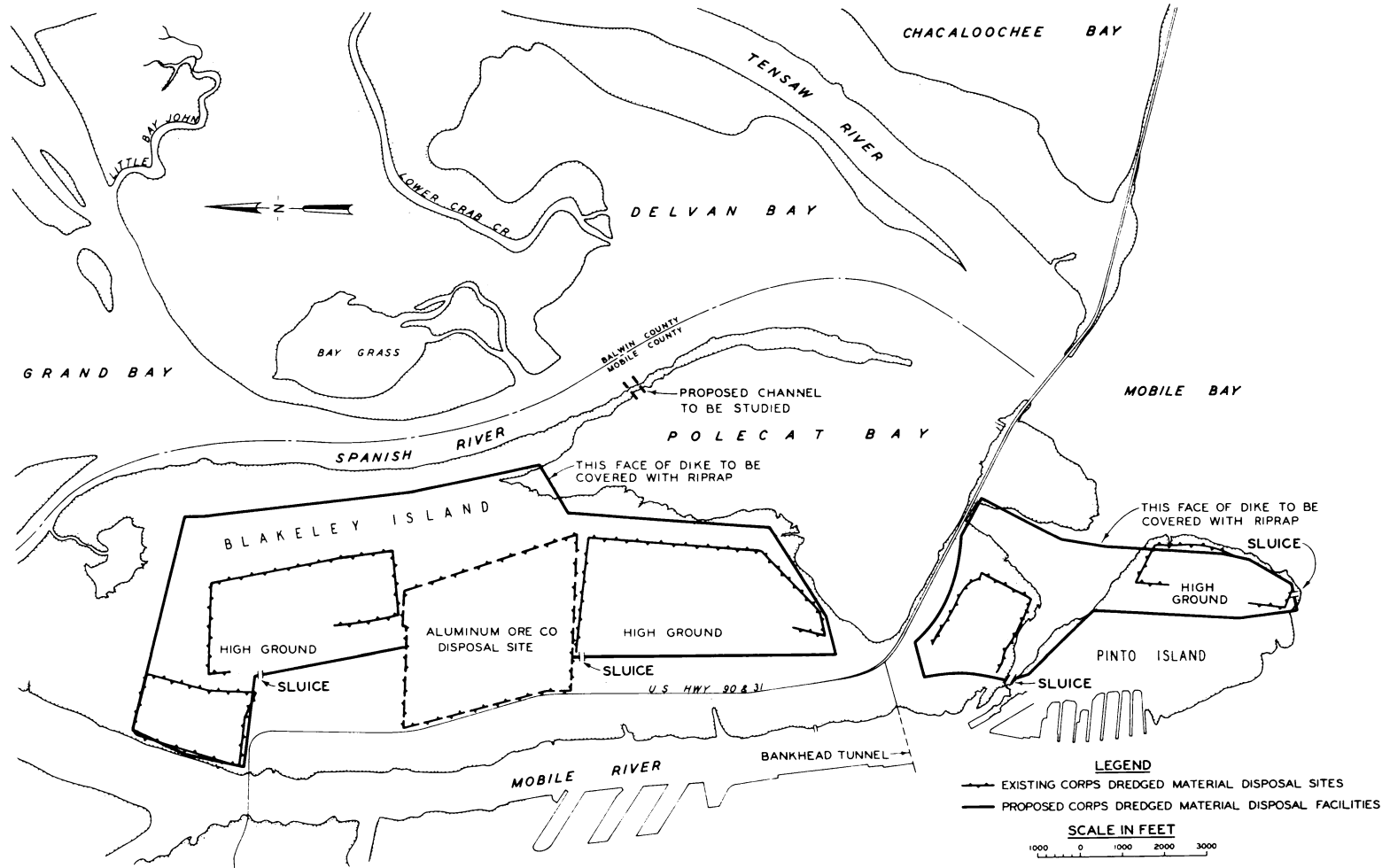

Fig. 2. Long-range dredged material disposal plan for Mobile Harbor, Alabama (Mobile District)

Norfolk Harbor

22. The large Craney Island facility in Norfolk Harbor is nearing capacity and must be replaced. Several replacement alternatives have been suggested by Norfolk District. Long-distance pumping of dredged material to a large tract in the northern tip of Dismal Swamp, using part of the present Craney Island site as a rehandling basin, reportedly is the most likely prospect.⁸ That alternative would satisfy the dredging needs of the Norfolk Harbor-Hampton Roads vicinity for about 45 yr.

Delaware River

23. Philadelphia District analyzed the existing disposal sites for the Delaware River area and concluded that maintenance dredging can continue under the present approach until 1990.⁴ To solve the problem of eventual loss of disposal areas, the District recommended development of new techniques and equipment for dredging shoal material and transporting it to disposal areas up to 50 miles* away. The major plans resulting from the investigations were development of a new dredging plant specially designed for the Delaware River (fig. 3) and use of rehandling basins and long-distance pipelines for transporting dredged material to disposal areas (fig. 4).

Calumet Harbor

24. The pilot study under way in the Great Lakes was authorized in the Rivers and Harbors Act of 1970 to provide disposal sites for the dredging needs of that decade. One site is proposed for the Calumet Harbor, Illinois, area (Chicago District) at a cost of \$9 to \$14 million. The Chicago District was dissatisfied with the relatively limited life span of such an expensive facility and therefore proposed to develop an acceptable long-range disposal plan for Calumet Harbor.⁹ The approach recommended was use of dredged material for beneficial purposes to permit disposal areas to be emptied and reused. The proposal includes results of a literature search to determine what agencies were making

* A table of factors for converting British units of measurement to metric units is presented on page vii.

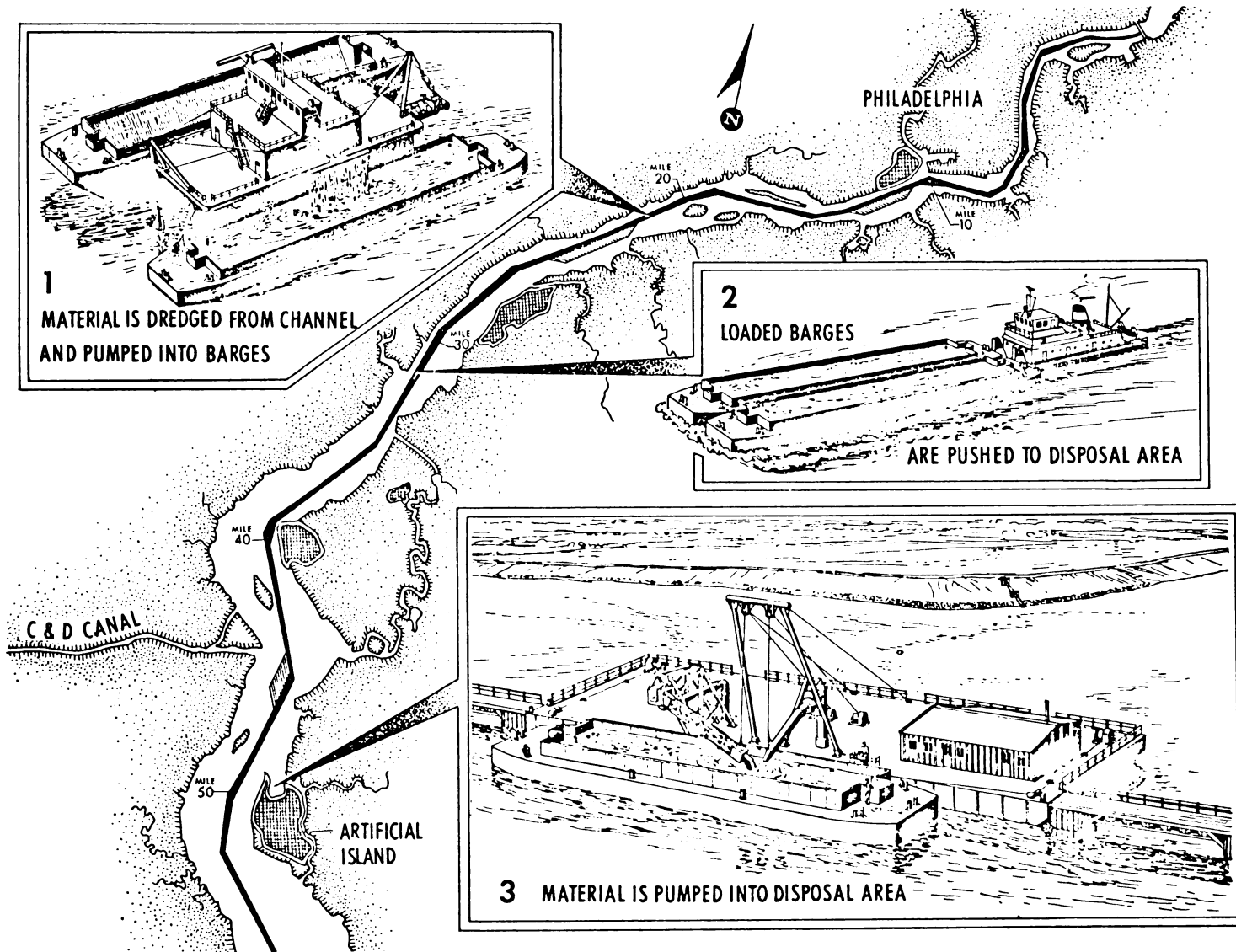

Fig. 3. Proposed special Delaware River plant system⁴

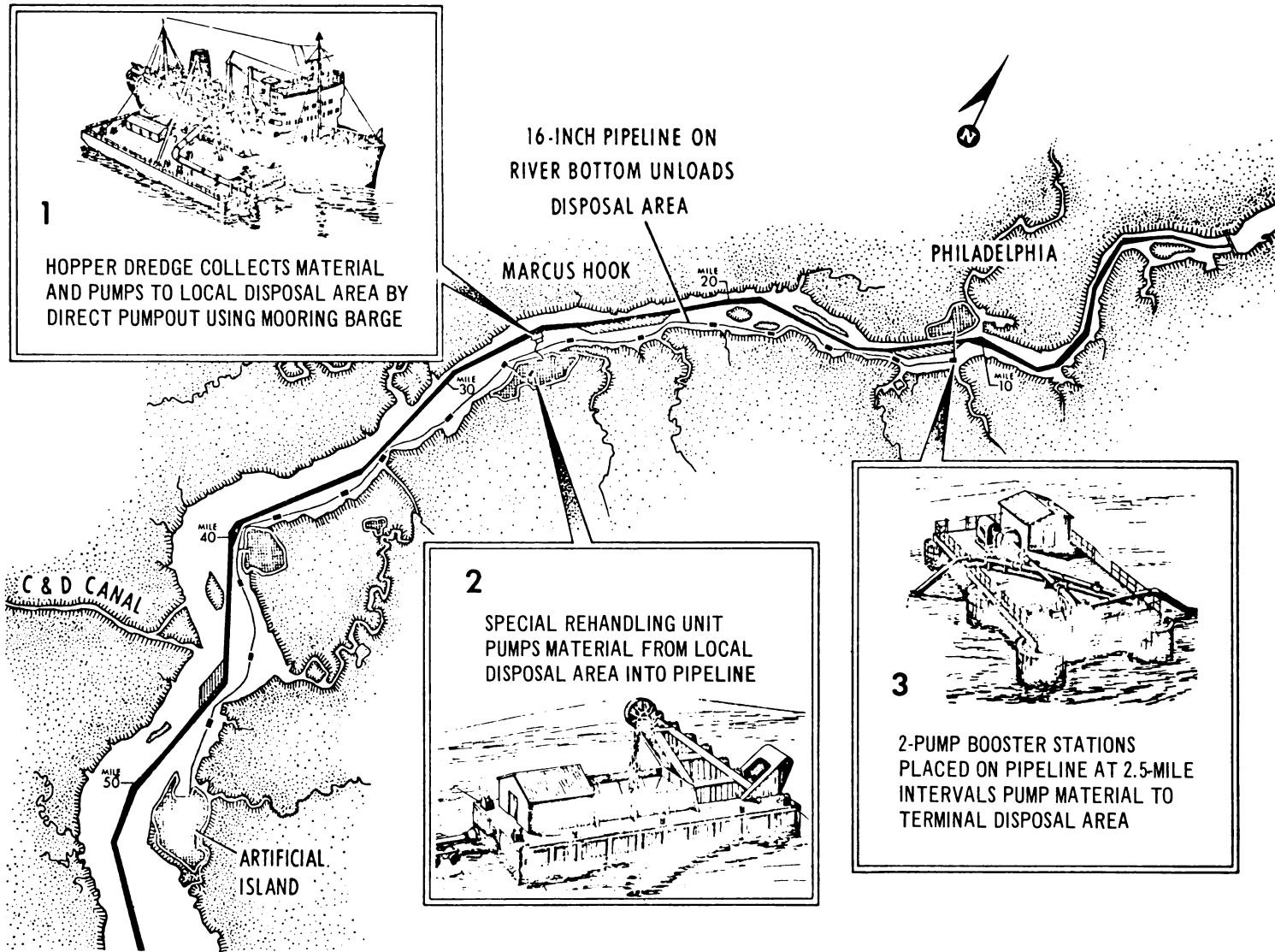

Fig. 4. Suggested rehandling and long-distance piping for dredged material disposal on the Delaware River⁴

applicable studies and field investigations into the nature of confined dredged material. The report concludes that recycling of dredged material is feasible. However, the few investigations of recycling are so recent that results are unavailable.

Coos Bay, Oregon

25. A proposed 30-yr development plan for management of dredged material in Coos Bay, Oregon,¹⁰ calls for consolidation of the existing numerous smaller disposal sites into larger, more strategically located areas, most of which would be diked. The material would be hopper dredged and disposed of by either a rehandling sump allowing access by the hopper dredge or by a pumpout mooring system.

Summary

26. These examples serve to illustrate the considerations involved in long-range dredging and disposal planning. They indicate that disposal facilities in the future will be consolidated in number and located farther from the dredging locale. New dredging techniques and equipment will probably have to be developed to lower operating costs. Dredged material that can be moved and used for beneficial purposes or placed in permanent inland disposal sites will allow emptying and extended use of disposal sites located near the dredging operations. The most important realizations, however, are that long-distance piping or hauling of dredged material will likely be necessary and that its cost will necessitate careful planning of all phases of the dredging and disposal system to achieve the greatest possible efficiency.

Multiple Use of Disposal Areas

27. Multiple use implies the reuse of a disposal site or of the material contained within it. The benefits derived from reuse may be systematically planned by man, as in the development of recreational areas, industrial sites, and wildlife habitat, or may be haphazard exploitation by natural organisms, as exemplified by shrimp spawning on newly created tidewater dredged material mounds or wild tomatoes thriving in the organic silt deposited in an upland disposal area.

Dredged material uses

28. Investigations are under way to determine beneficial uses of the dredged material itself. Clemson University, for example, in a contract with Charleston District, is investigating the manufacture of lightweight ceramic aggregate from dredged material. Use of dredged material in brickmaking was investigated in the Philadelphia region although negative results were obtained. The placement of suitable sandy dredged material for replenishing beaches is common on the east coast. North Carolina State University is working with the Wilmington District on the feasibility of creating marshland with dredged material. The Norfolk District and such research institutes as the Virginia Institute of Marine Science and the Coastal Engineering Research Center are also involved in marsh creation. An engineering firm working on an interstate highway in Florida is considering stockpiling sandy dredged material from a local dredging operation as a source of highway fill. The Seattle and Sacramento Districts have similar projects. A Jacksonville, Florida, landowner capitalized on the disposal of dredged limestone on his land by crushing it and selling it as aggregate.

29. The Philadelphia report⁴ presents an excellent analysis of conditions and problems associated with use of disposal areas for agriculture, housing, and industry as studied in four confined disposal areas on the Delaware River. The studies center on highly organic silty and clayey dredged material of originally high water content that has undergone varying degrees of drying and stabilization over the years. This kind of material is extremely difficult to reuse for industrial fill and, if accompanied by a high groundwater table, for support of crops. The study therefore applies to other regions of the country having disposal areas that are poorly suited for reuse.

Agricultural uses

30. Dredged material with appreciable organics could serve as a growing medium for many crops. Reportedly, a cornfield produced a higher yield after dredged material was placed on it. Tomatoes grow profusely in part of the large Eagle Island containment facility in Wilmington Harbor, North Carolina. A farmer at Wishart Point, Virginia,

increased the potential value of his farmland by removing and stockpiling its topsoil and allowing the Norfolk District to dispose of sandy dredged material in the area. He then replaced the topsoil to continue farming until the selling price of land for residential and industrial development rises. Portions of the disposal areas used in the excavation of the Sacramento Deep Draft Channel have been reclaimed for farming.

Recreational uses

31. The high water content of most hydraulically dredged material coupled with its extremely poor ability to drain creates poor foundation conditions and limits the use of the disposal area in many cases to supporting very light structures, such as those found in recreational facilities. The Philadelphia study⁴ states that the following are problems to be expected in reuse of disposal areas for support of structures and associated features:

- a. Excessive long-term settlements and limited stability of the deposits.
- b. Support of building foundations on fills or on piles driven to a relatively deep stratum.
- c. Settlement of yard levels, pavements, and utilities with respect to pile-supported structures.
- d. Excavation below a high groundwater level.

32. Perhaps the most ambitious program proposed is the creation of two large city parks from diked disposal areas for the Connecting Channels Program in Detroit. Federal funds will enable the Huron-Clinton Port Authority to develop the parks at Point Moulet in the Detroit River and Dickinson Island in Lake St. Clair. The parks will provide fishing areas and boat launching ramps on the stone-protected embankments and picnicking and sports facilities within the area itself. Recreational potential was cited by the Galveston District¹¹ in the design memorandum for the Sabine Lake disposal areas in Port Arthur, Texas. Asphalt will be placed on the crown of the riprapped embankments of the disposal sites. The design memorandum suggested that this feature could be developed by local interests as an access road for fishermen and visitors and that turnarounds provided in the original construction would be left in

place for future use. The local sponsor will take the responsibility for law enforcement on the facilities and protect the Federal Government from liability for accidents or damage resulting from use as a recreational area.

33. A marshy disposal site on Philadelphia District's Chesapeake-Delaware Canal, Welch Point, is being converted to recreational purposes by topping it with sand and then grading and seeding it. When completed, the area will be State operated. Chicago District's design of a containment facility at Milwaukee Harbor for later development as a park with fishing facilities differed from that of the sites mentioned above. The District felt that riprapped dike protection would inhibit fishing in the Milwaukee Harbor area, presumably because of the high waves generated in the deep water (up to 24 ft). For this and more critical reasons, the District recommended a vertical-faced cellular steel sheet pile structure for part of the dike and less expensive rubble mound (earth- and rock-fill embankment) for the remainder. Steel sheet pile structures have also been proposed for containment facilities at Waukegan and Buffalo Harbors.

Industrial fill

34. Examples of industrial and other developments of disposal sites are numerous in spite of the poor foundation conditions prevalent in many areas. Along the Gulf Coast in the Mobile District, coastal and lowland disposal areas have been converted to sites for shipbuilding facilities, a coal handling plant, a bridge and ironworks, seafood processing plants, ice plants, heavy manufacturing industries, and settling ponds for oil storage facilities. The CE constructed its own shipyard with access roads and dock facilities on a former disposal area.

35. Food handling facilities in south Philadelphia and the Philadelphia airport are located on sand and gravel dredged fills. A portion of Artificial Island (fig. 3) is the site of a nuclear power generating plant, and the Philadelphia District expects that more of the island will be developed as the value of the area increases.

Special applications
of dredged fill material

36. Hydraulic dredging has also been used successfully in specially appropriated programs for construction of fills for airports and industry. Such programs, however, do not relate directly to multiple use of disposal sites for several reasons:

- a. Only selected fill material is used, with allowances for rejection of undesirable material and specification of borrow areas.
- b. Sufficient time is allotted for drainage of dike and fill constituents.
- c. Funding can be arranged for sufficient time to complete the project rather than on an annual contract basis.
- d. Sounder engineering design and construction methods can be justified by the requirements of the facilities for which the fill is created.

Nevertheless, the techniques employed in such programs are useful in demonstrating what can be done with hydraulic dredging and with construction-quality materials found in some dredging operations. The Vicksburg Harbor industrial fill was proposed to provide an easily accessible industrial site, above flood stage, to allow local trade interests to take advantage of cheap river transportation on the Mississippi River. This project consists of a harbor channel adjacent to the industrial fill, an approach channel connecting the harbor channel with the Mississippi River, the 2-mile-long industrial fill, and a highway and railroad approach fill. Fig. 5 shows the key features of the project. Vicksburg District completed the project in 4 yr at a cost of about \$5 million. The fill was constructed chiefly by hydraulic dredging of selected areas. Fill material was dredged from the harbor channel and an adjacent area and placed behind 28-ft-high earthen dikes constructed with selected material borrowed from the drainage ditch and channel excavation. Fig. 6 shows the project under construction, and fig. 7 shows the completed fill occupied by several industrial structures. The Philadelphia report⁴ discusses the use of preloading and vertical sand drains in consolidating dredged slurry to prevent settlement of subsequent construction. A subsurface sand drainage layer was

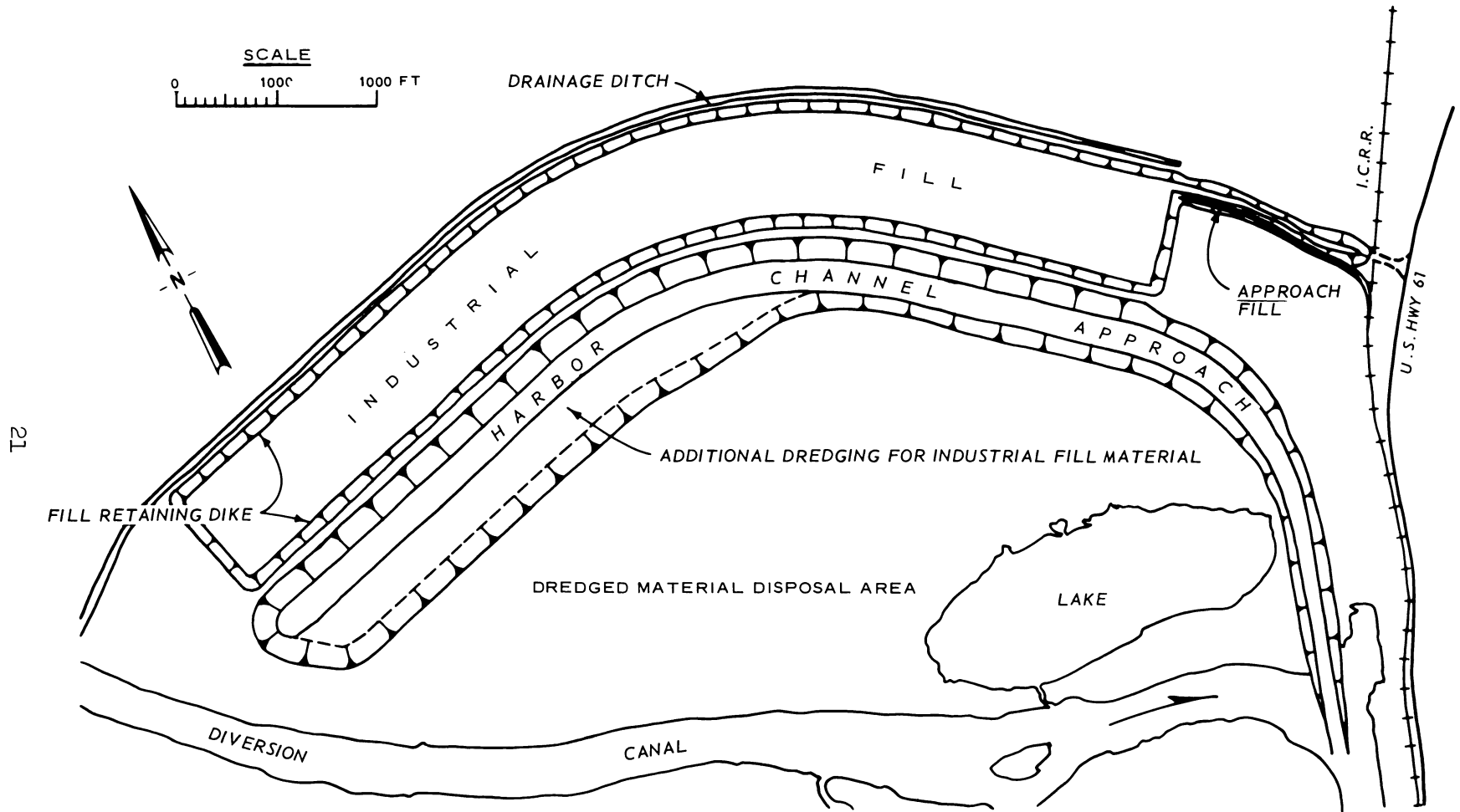

Fig. 5. Plan of Vicksburg Harbor industrial fill (Vicksburg District)



Fig. 6. View of Vicksburg Harbor industrial fill under construction. Hydraulic filling in progress (Vicksburg District)

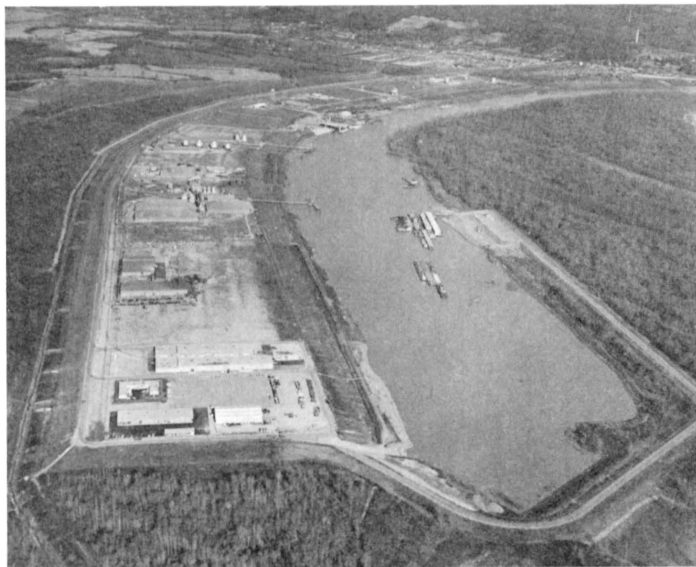

Fig. 7. View of Vicksburg Harbor industrial fill after occupation by several industries (Vicksburg District)

used in the Vicksburg industrial fill for that purpose.

Feasibility of disposal area reuse

37. Conclusions from the Philadelphia report⁴ state, on the basis of engineering investigations of dredged material in the four sites studied, that:

- a. So far as trafficability and water table are concerned, the disposal areas can be used agriculturally after drying periods of 2 to 6 yr. Development for industrial-commercial use can begin after similar time periods.
- b. The areas can be developed for light industrial occupancy without extensive stabilization, but restrictions on building design to allow for settlement would severely limit the types of industry.
- c. By use of proper stabilization procedures to minimize post-construction settlement, the areas can be developed for light to medium industrial occupancy.

PART III: CONTAINMENT AREA DESIGN AND OPERATION

Preliminary Site Considerations

38. An efficient containment facility provides for sufficient removal of solids and pollutants from the dredged slurry, confines the slurry within the designated area to prevent damage to or inundation of the surrounding areas, and has sufficient volume for long-term usage and sufficient areal extent for maximum drying of dredged slurry. In practice, few disposal areas satisfy these requirements because:

- a. Too little planning and design are involved in developing adequate containment dikes and sluice* facilities.
- b. Settleability characteristics of the solids and pollutants in the dredged slurry are not sufficiently known.
- c. Large-area, long-term easements have been difficult for most Districts to acquire or to finance.

39. Containment facility efficiency is affected by the size of the disposal area, the disposal methods, the kinds and quality of dike and sluice facilities, and the operation of the area during disposal to control effluent quality and to prevent degradation of the facilities. Dike design and construction are discussed in Part IV of this report.

40. Water entering a containment area as part of the dredged slurry forms a pond. Pond depth is the depth of water overlying the settled solids within the disposal area at any given time. The meanings of the terms "ponding time" and "detention time" are unclear. Apparently, they are used loosely in discussions of CE disposal operations. Broadly speaking, detention time denotes how long a segment of dredged slurry (water plus solids) is detained within a containment facility from the time it is discharged into the area until it is removed by sluicing. Ponding time is sometimes used interchangeably with detention

* The term "sluice" refers to any structure placed in a containment facility dike to control the release of excess water from the facility. The term "weir" refers to a gate, such as a removable board, placed across the disposal area side of the sluice to control the water level within the area.

time, but the term has also been used to define the length of time that the contained slurry and ponded water are detained by closing the sluice after the dredging operation has ceased (see Jacksonville usage, paragraph 96).

Site selection

41. The cost of dredging and disposal operations commonly limits the choice of a disposal site to the largest available area near the channel being dredged. Proposed sites are further eliminated by difficulties encountered in acquiring easements. Dredging for which retention of dredged material has been stipulated requires disposal sites capable of being diked (that is, those on land or in shallow water); depressed areas, such as borrow pits; or areas ringed partially by foothills that form natural barriers to runoff. Borrow pits have been successfully used in CE operations and are being considered further for acceptance of dredged slurry transported long distances by pipeline. Material dredged from the Little Calumet River (Chicago District) is being piped a distance of 1 to 2 miles to an abandoned 17-acre clay pit 20 to 25 ft deep. The effluent is being withdrawn with pumps. Once the area is filled, it will be diked at the lower end. The District has also considered using an abandoned strip coal mine located 40 miles inland. Sand and gravel borrow pits have occasionally served as acceptable dredged material retention facilities for Norfolk District.

42. Costs of confinement facilities have been reduced by using natural foothills behind disposal areas on or near the bank of a river (riparian sites) in lieu of dikes. Fig. 8 shows such a disposal area for the Sacramento River Deep Draft Ship Channel (Sacramento District). The 60-ft contour defines the limits of the disposal area to the west; dikes form the boundary on the north and south ends and on the riverbank. A high bluff bordering the Houston Ship Channel's Spillmans Island disposal area (Galveston District) similarly forms part of the containment barrier for that site. These examples should not be confused with the practice of partial diking of a riparian disposal site, in which the effluent is allowed to find its way back to the channel indirectly through natural drainage behind the area. No

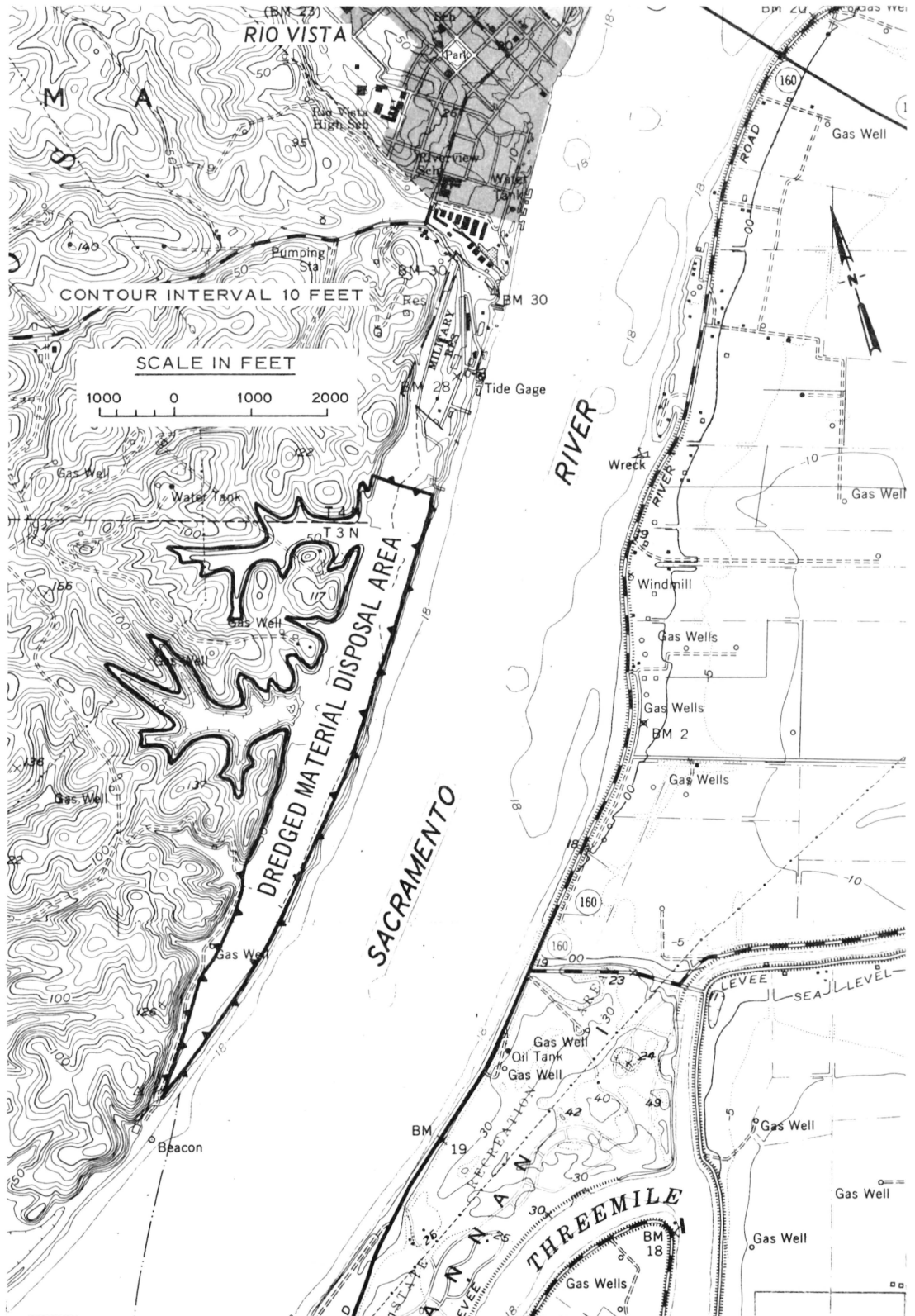

Fig. 8. Disposal area for Sacramento River Deep Draft Ship Channel.

designated effluent control is implemented in the latter case, and the disposal area is not considered a confined one.

43. Project specifications normally indicate the areas to be used by the contractor for disposal of dredged material. The contractor may elect, however, to use an area other than that furnished by the Government. His reasons for doing so may include an agreement with a particular landowner or a desire to use a site more adaptable to a particular operation. The technical provisions of the dredging contract commonly include provisions for accommodating the contractor in this regard. If the contractor elects to supply disposal areas, however, he accepts full responsibility for obtaining written consent of landowners, submitting descriptions of the proposed areas to the CE, and obtaining the consent of the proper environmental agencies for use of the area. He normally must absolve the Federal Government of all responsibility for consequences stemming from disposal area operations. The contractor must also absorb all expenses incurred in acquiring and preparing such areas. If use of an alternate site is requested after award of the contract, the contracting officer must approve the request and make applicable changes to the contract to protect the Federal Government's interests. In practice, the contractor rarely exercises the option of using sites of his choosing, primarily because of the time involved in obtaining approval from the proper environmental agencies.

44. Some projects in the New Orleans and Sacramento Districts do not provide for the use of alternate disposal areas, reportedly more because of the delay in gaining site approval than because of benefits to be realized otherwise through proper disposal area planning. Nevertheless, more effective planning and preparation for proper area operation are possible in these projects because the location, approximate size, drainage conditions, probable pipeline discharge locations, and other factors are known before the start of dredging operations. Elsewhere, efficiency gained in thoughtful planning for disposal on a particular project may be lost when the contractor exercises his option of using an alternate site because features of the new site are

unfamiliar. Since it is probable that more emphasis will be placed in the future on effluent quality control and stabilization of dredged material within disposal areas, maximum preproject planning and foresight in dredging and disposal operations will be required. Permitting the selection of alternate disposal areas by the contractor is not always compatible with efficient planning; therefore, curtailment or regulation of this practice may be necessary in future dredging contracts.

Disposal area size determinations

45. The limits of available disposal area leases are usually designated on plans accompanying contract specifications. Commonly, the dike location and consequently the exact limits of the disposal area are specified, but for some contracts only the general location of the disposal site is shown with the dike center line to be located as needed by the dredging contractor or the contracting officer. In this case, no precise determination of disposal area size can be made beforehand, and, accordingly, no accurate estimation of detention time, sluice locations with respect to discharge points, and other factors affecting containment facility efficiency can be made. Fig. 9, which is taken from a recent contract drawing of the Mobile District, provides much of the information needed for proper area evaluation as mentioned above.

46. Design factor. Many Districts apply a design factor to the volume of material to be dredged in determining the capacity of the containment facility needed to retain the dredged material at a recommended freeboard. The design factor is called the "fluff" or "bulking" factor by most Districts, but these terms should be restricted to references to expansion of dredged material, which is usually only one parameter making up the design factor. The various design factors consider some or all of the following parameters in estimating required disposal facility volume:

- a. Volume of material to be dredged.
- b. Payable and nonpayable overdredging.

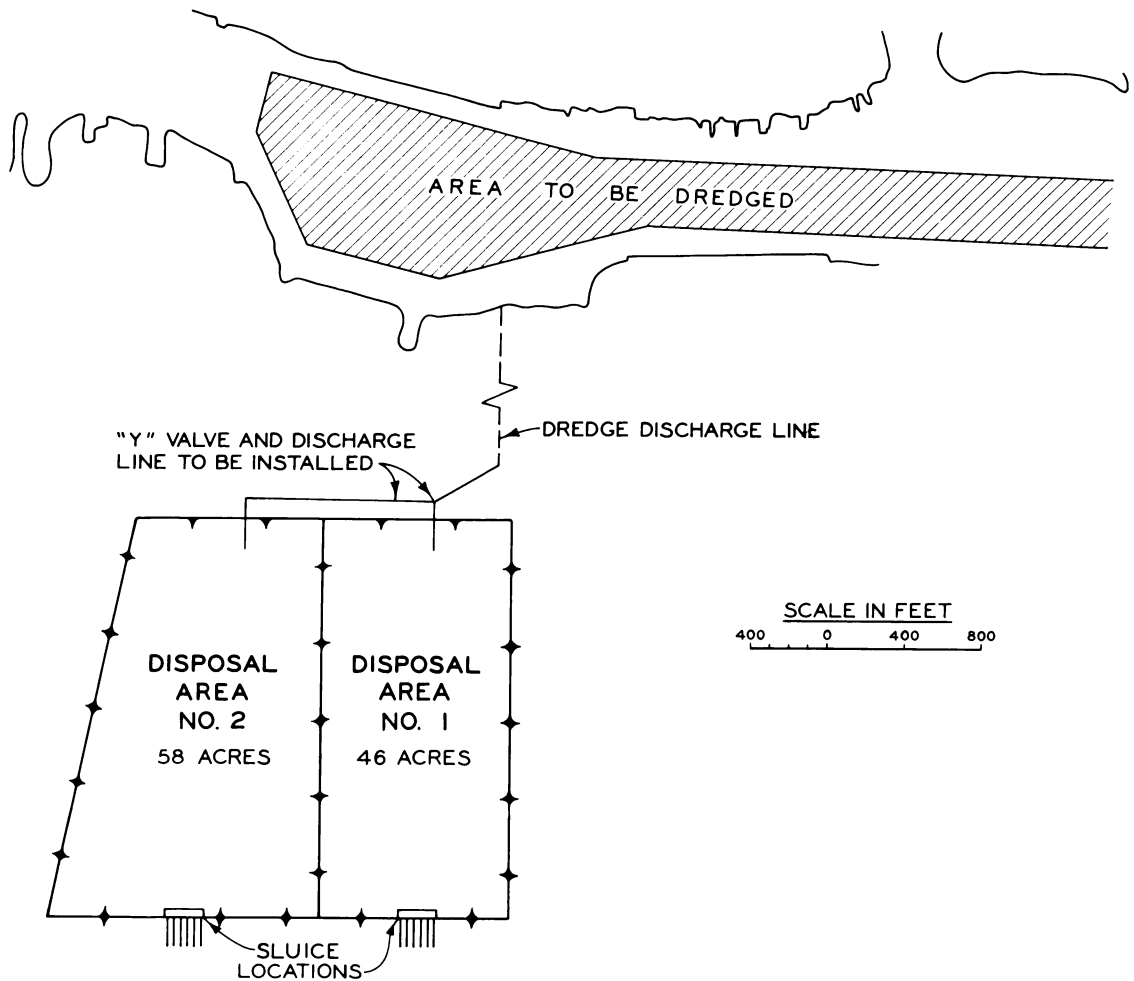

Fig. 9. Portion of a dredging contract plan showing position of disposal area dikes, sluice locations, discharge line position, and required dredging (Mobile District)

- c. Expansion of the dredged material (fluff or bulking factor).*
- d. Ponding or detention time.
- e. Runoff of excess water through the sluice.

47. The design factor generally decreases with increasing

* The volume occupied by an excavated material has been compared with that occupied by the in situ material. Sand occupies about the same volume, sandy clay about 1.25 times as much, clay about 1.45, and gravel and rocks about 1.75.¹²

grain size* from about 2 for silts and clays to about 1 for sands. It has commonly been derived through trial and error. One District uses only a 30 percent overdredging factor in capacity determinations with no bulking factor applied. Design factors are probably more valid for the coarser sediments, because these settle out rapidly and are less dependent on ponding time for their removal from the effluent. Some of the finer sediments, however, especially those with colloidal-size particles, remain suspended much longer and require longer detention times. (Some of these could require even more sophisticated solids removal techniques, such as filters, clarification basins, flocculants, etc., depending on effluent quality requirements.) The result is that the generally used design factor of 2 for fine sediments may underestimate disposal area capacities. The fact that many District specifications include a "shut-down clause," that is, a requirement of the contractor to cease disposal operations in the event of dike failures or of failure to meet freeboard or effluent quality requirements, indicates that sufficient capacity for the sediments dredged is sometimes not provided. A standardized list of parameters, which might include the five mentioned above, is a critical research need for determination of an effective design factor.

48. Settlement of disposal area. Settlement of the soils underlying a disposal area sometimes yields a capacity greater than that originally estimated. Settlement by consolidation in the Craney Island facility at Norfolk increased its volume by approximately 20,000,000 cu yd, based on the original plan of eventual raising of the dikes to +18 ft mlw. Some disposal areas along the Gulf Coast and a marshy site at Green Bay, Wisconsin, have also increased in capacity by foundation settlement. Long-term containment facility planning should investigate the possibility of predicting settlement of an area as an aid in estimating the true capacity of proposed facilities.

49. Dredged slurry discharge rate. The rate at which the dredged slurry is discharged into the disposal area affects the detention time

* This is true only for materials through sand size because gravel and broken rock occupy more volume disturbed than in situ, presumably because of poor fit of the fragments.

and the capacity required. The diameter of the pipeline and the distance pumped influence the rate of discharge. If the size of pipe to be used is not known, it may be difficult to estimate accurately the required containment facility volume. The policy under which CE Districts operate with regard to contract specifications prevents them from prescribing dredge or discharge line dimensions; hence, the problem must be handled by providing a disposal area of sufficient size to handle the largest pipeline to be expected or by enforcing shutdown clauses as discussed in paragraph 47.

Disposal Methods

Hydraulic methods

50. Dredged material is conveyed into disposal areas either hydraulically or mechanically. Hydraulic handling of dredged material is by far the more common method. It is accomplished by pumping through submerged or floating pipeline from a pipeline dredge, through direct pumpout from a hopper dredge moored at the disposal site, or by a combination of the two methods through the use of a rehandling basin that receives dredged material from the hopper dredge or from scows which is then pumped out into the permanent disposal area. Pipeline installations and size are discussed in paragraphs 97 and 98.

51. Rehandling basins and hydraulically unloaded scows. Rehandling basins serve to reduce the piping distances and number of booster pump stations necessary to pump dredged material to centrally located disposal areas. These also take advantage in confined disposal operations of the operational speed of hopper dredges and dump scows. For a portion of the Houston Ship Channel maintenance dredging, for example, dredged material was pumped from the dredge to a temporary rehandling location in a turning basin and then redredged with a larger dredge for disposal in a permanent retention facility away from the channel.

52. A Philadelphia area contractor economizes on his disposal operations by using a rehandling basin adjacent to two of his disposal sites. The contractor hauls the material from the dredging area to the

basin in scows, dumps it, and redredges it hydraulically for disposal in the retention facilities. Scow hauling is cheaper than long-distance piping for this contractor, and he is consistently able to bid lower on CE contracts, thus monopolizing dredging in that vicinity. Hydraulic unloading of material from loaded scows is used extensively by the Buffalo District. However, the necessity to draw water from the area around the scows for washing them out causes temporary turbidity in the area. Part of this method is therefore objectionable. Consequently, the Buffalo District has proposed the creation of a small diked pool in one corner of the large diked facility at one of its Cleveland Harbor disposal sites to supply water for washing out the scows. Thus, the same water is recycled from disposal area to scow and back to disposal area, eliminating the need to draw water from the surrounding area.

53. Norfolk's Craney Island facility provides a special rehandling basin with access channels for scows and bucket dredges (fig. 10). The basin is 40 ft deep and about 1000 ft square with a capacity of about 1,000,000 cu yd. This is the average annual amount dredged by bucket and scow. A stone spur dike prevents discharged slurry from being carried away from the basin by tidal currents.

54. Hopper dredges. Seven of the 16 CE-owned hopper dredges are equipped for direct pumpout of dredged material via mooring facilities. They are the Goethals and Comber of the Philadelphia District, the Markham, Hoffman, and Lyman of the Buffalo District, the Hains of the Detroit District,¹³ and the McFarland of the Galveston District. Hopper dredges so equipped can be used effectively in heavily trafficked ports and waterways where confined disposal is often required and where pipeline dredges hinder navigation.

55. The Detroit District uses hopper dredges for most of its maintenance dredging work. Disposal is by direct pumpout from the hopper to the containment facility. Mooring facilities at Craney Island allow hopper dredges to unload in 1 hour into the disposal area through a submerged pipeline (fig. 10).¹⁴ Direct pumpout of hopper dredges may eventually replace barge scows in the Buffalo District.

56. Long-distance piping. For the purpose of this report,

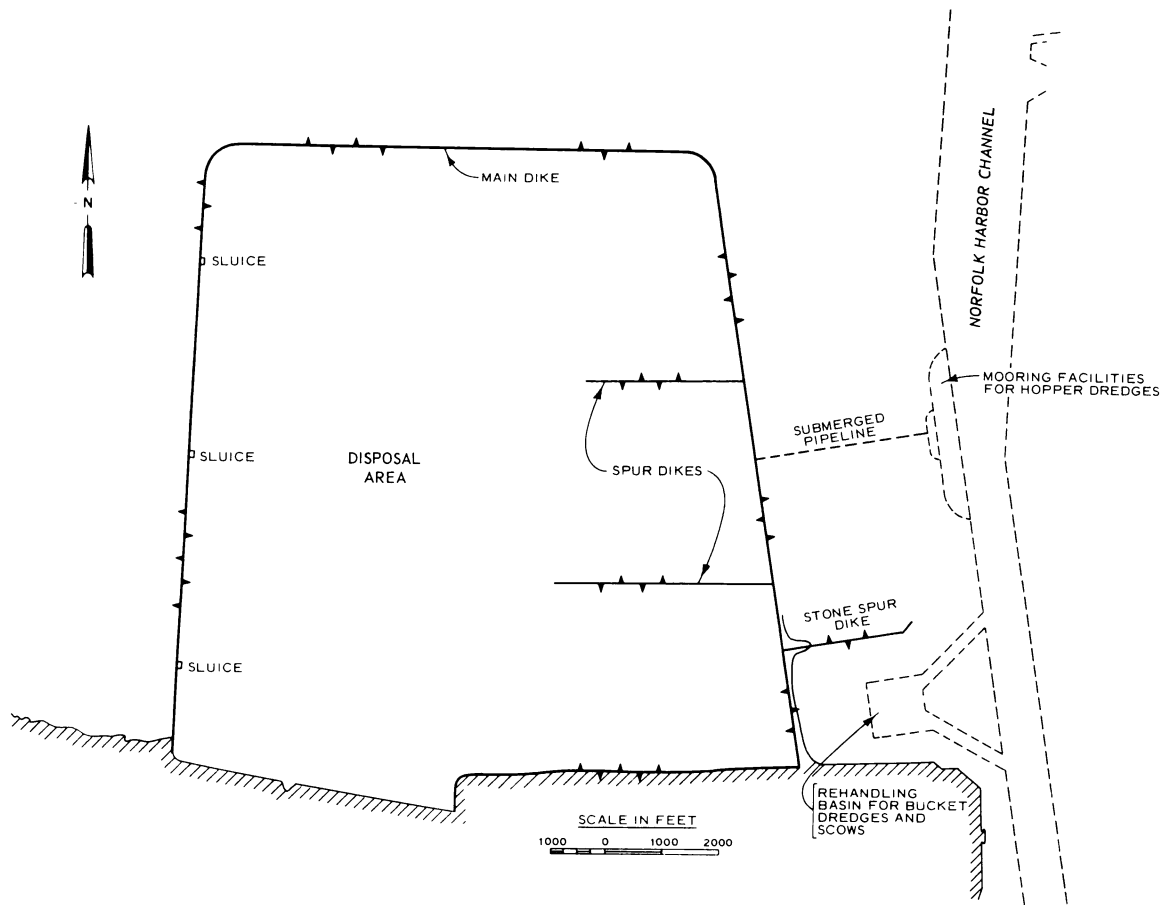

Fig. 10. Plan of Craney Island disposal facility showing rehandling basin and hopper dredge mooring facility (after reference 14)

long-distance piping is defined as hydraulic transport of slurry through pipelines sufficiently long to require the placement of one or more booster pumps within the system. Results of a study and field tests reported in the Philadelphia District report⁴ indicate that pump station spacings of 12,500 to 15,000 ft are practical. This agrees with the 2- to 3-mile pump spacing interval used on a long-distance hydraulically dredged fill for highway construction, which is discussed in paragraph 57. Local interpretations of long distances may vary, however. For example, in Everett Harbor, Washington, the local interest was required to pay additional costs of piping dredged slurry for distances exceeding 1 mile.

57. Examples of long-distance slurry transportation in industry are numerous. A recent report¹⁵ on slurry pumps recorded transport of

coal slurry (concentration 50 percent by weight) 273 miles through 18-in. pipe using four booster pump stations, and movement of waste tailings by the Japanese 44 miles through 12-in. pipe using only one pump station. The waste tailings were slimes (90 percent passing a No. 400 sieve) with a weight concentration of 18 percent. The highway fill mentioned above (paragraph 56) involved the construction of a portion of Interstate 10 through the swamps between Baton Rouge and New Orleans, Louisiana.¹⁶ A 30-in. hydraulic cutterhead dredge removed sand and silt from the Mississippi River and pumped it through 10 to 15 miles of pipe for construction of the road embankment. The dredge pumped a slurry of 14 to 18 percent solids at a rate of 1000 cu yd per hour through a 24-in. pipeline to the first booster pump. From there, a 25-5/8-in. oil pipeline was used to convey the slurry to the remaining six booster stations. Pressure ranged from about 125 psi at the booster pumps to 20 psi at the end of each booster line. The embankment was advanced at the rate of 200 linear ft per day in this manner.

58. This highway fill project indicates that long-distance piping can be achieved using a continuously operating dredge in series with long pipelines and booster stations. Philadelphia District⁴ recommended a semiportable dredged material rehandling unit in the vicinity of the dredging operations that would uniformly convey material of below a certain limiting size to the first booster station by means of a hopper (see inset 2, fig. 4). A chain bucket dredge was recommended for the rehandling unit because of its small size and power requirement and its ability to deliver the material at higher concentrations than other methods. Literature and field investigations concluded that a transport velocity of 12 ft/sec is a conservative optimum for dredged slurries and that particles as large as 2-1/2 in. in diameter can be carried efficiently at that velocity. Booster stations would each consist of two pumps arranged in series on a permanently installed platform and would be spaced at 12,500-ft intervals (see inset 3, fig. 4). Further details concerning the computations and criteria used in deriving these values can be obtained from the Philadelphia report.⁴ Fig. 4

illustrates the use of the booster stations and rehandling units as installed in the dredged material disposal system.

59. Long-distance piping has been used for CE dredging projects, especially along the Gulf Coast, at distances up to about 5 miles, but is not used extensively throughout the CE. The Philadelphia and Charleston Districts have proposed such operations as discussed earlier in this report. The Jacksonville District's upcoming Fort Pierce Harbor project likely will involve long-distance hydraulic disposal of dredged material. The Chicago District considered using an existing 40-mile, small-diameter coal slurry pipeline to pump material from the dredging area to disposal in an abandoned strip coal mine but concluded that the pipe diameter was too small for the distance involved. The Craney Island replacement study in Norfolk District may recommend a disposal site in the Dismal Swamp area. This would involve the redredging of material deposited initially in a part of the existing Craney Island facility for piping 10 miles upland to a proposed permanent 5000-acre disposal site.

60. The concept of long-distance piping of dredged material is not without problems. Objectionable dredged material, such as scrap iron and rock fragments greater than a few inches in diameter, must be segregated from material entering the pipeline. Thus, rehandling facilities will be required in most cases. Booster stations, pumps, power requirements, and extra personnel add appreciably to the cost of the system. One District felt that easements for such long pipelines would be difficult to acquire in heavily populated regions and leaking pipelines could result in lawsuits. The many examples of existing long-distance hydraulic systems, however, indicate that these problems can be overcome and that the concept is feasible.

Mechanical methods

61. Dipper dredges, bucket dredges (especially draglines), and ladder dredges are used occasionally for conveying dredged material into a disposal area but are limited to very small dredging jobs, dredging of oversized debris, and to secondary tasks such as dike building and clearing out of rehandling basins on major jobs. Bottom dumping of scows has

been used in filling a confined disposal site at Indiana Harbor (Chicago District). There are two diked containment facilities in this harbor owned and built by Inland Steel Company as fill extensions for its plant. The smaller area, enclosed by a steel cofferdam, was used once in 1969 for the disposal of 80,000 cu yd of CE maintenance dredgings. A gap in the dike allowed access by dump scows. The District experimented with the use of an air barrier employing air bubbles released to the surface from the bottom of the gap to prevent the escape of suspended particles. This met with only limited success. The larger disposal facility involves about 745 acres within a dike of 50-ft-diam steel cells. It is partially filled with a porous slag on which the steel company is allowing the CE to deposit 1,000,000 cu yd of fine-grained, polluted dredged material over a 10-yr period. The intake pipe for the steel plant is within this area, and to prevent fouling it with the dredged material, the company requires the CE to bottom dump from scows in one area at a time to minimize turbidity. Water inside and outside of the 200-ft-wide access gap will be monitored to check for material escaping through the air barrier.

Effluent Sluicing Methods

Purpose and design and construction responsibilities

62. Sluices are provided in dredged material retention facilities to allow excess water of acceptable quality to be drained from the disposal area. Sluice configurations vary from a simple outfall pipe placed atop or through a dike to large wood- and steel-framed rectangular structures with multiple discharge pipes and stoplogs for an adjustable weir. Sluice design has received little attention in most CE Districts. Attempts at standardizing sluice design and construction have been unsuccessful because little is known of sluice characteristics as they affect effluent quality. The lack of data on the effects of sluice design on disposal area efficiency is the primary reason that many

dredging and diking contracts leave sluice placement and configuration up to the contractor.

63. Some Districts specify the minimum length of weir crest acceptable for a designated discharge pipe diameter, but the ratio of crest length to pipe diameter varies by District. This aspect of sluice design is discussed in paragraph 91. Maximum depth of water overflowing the weir is also specified at times. The Seattle District is attempting to determine a relationship between weir length and effluent quality (solids content) at a disposal site that receives fine-grained material, which is difficult to remove from the effluent. Experimentation like that at Seattle may lead to systematic improvement of sluice configurations and allow the CE more control on the quality of material passing the weir.

64. There are enough examples of sluice configurations specified in dredging and diking contracts and related in conversations to reliably classify the various types used in CE operations. These are described in the following paragraphs.

Outfall pipes and siphons

65. The simplest sluice is a pipe placed horizontally within the dike near its crest. As the level of the slurry rises, the upper portion runs off through the pipe. No precise level control is provided by this type sluice, and thus detention time and effluent quality are not controlled. The outfall pipes may become plugged and allow enough pressure to build up on the dikes to cause a failure. They are seldom used in CE operations and are limited to supplementary drainage through cross dikes within a large disposal area. A siphon is similar to an outfall pipe but is equipped with a pump to start the effluent flowing through the system. A 30-in. siphon was installed by Sacramento District to convey dredged material effluent from a city-owned disposal area into a CE-operated facility for eventual discharge through a CE sluice. A pump-out system is used in the converted clay pit disposal area for the Little Calumet River project in Chicago that was discussed earlier (paragraph 41).

Drop inlet sluice

66. The most widely used sluice in CE operations is the drop inlet. It consists of a rectangular wood- or metal-framed inlet or half-cylindrical corrugated metal pipe riser equipped with a gate of several stoplogs (usually 2- by 10-in. or similar sized timbers). The stoplogs can be added or removed as necessary to raise or lower the level of slurry within the disposal area. A discharge pipe leads from the base of the riser through the dike to the exterior (fig. 11). Ideally, the discharge pipe extends beyond the exterior of the dike or into a catch basin to prevent scouring of the exterior slope. Various

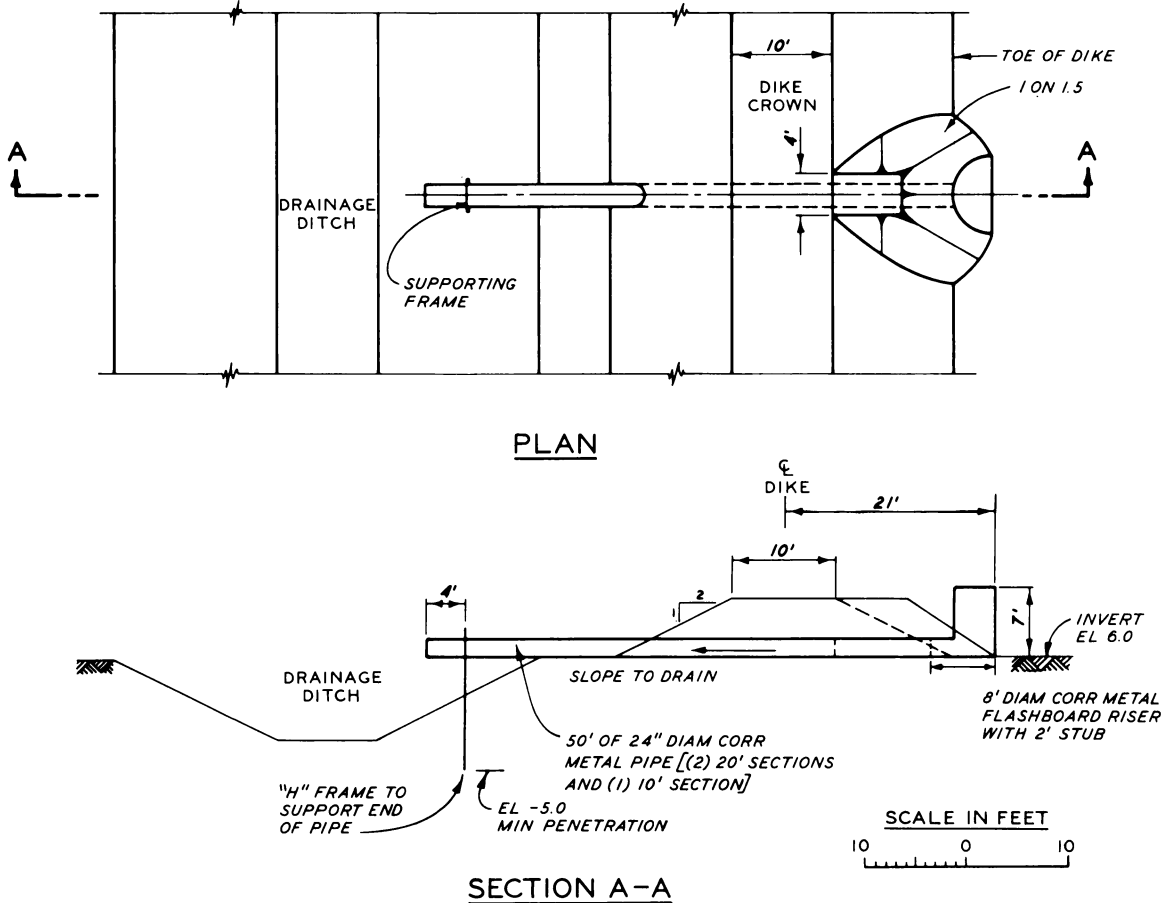

Fig. 11. Drop inlet sluice (pipe and riser) (Charleston District)

degrees of sophistication are achieved in this basic form by the addition of protected stilling basins or plunge pools and multiple-sided or "Y" gates (fig. 12). The 3500-acre disposal facility built in

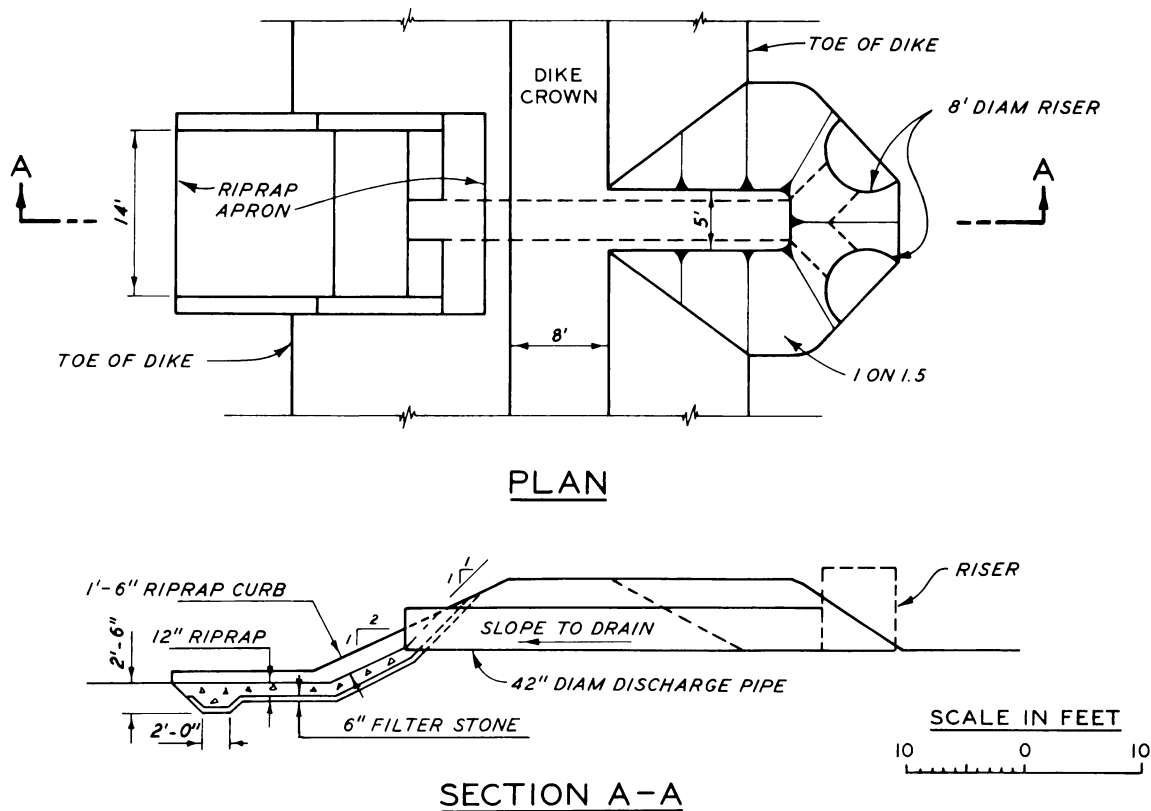

Fig. 12. Drop inlet sluice structure with stilling basin and "Y" riser configuration (Charleston District)

Sabine Lake in Port Arthur, Texas, includes an outlet channel in conjunction with each of two drop inlet sluices to achieve additional settling of solids before the effluent is returned to the navigation channel. A 6000-ft-long interior spur dike at each end of the retaining dike forms one side of the outlet channel, and the main levee forms the other (fig. 13). A containment facility that is tied into an existing flood control levee system may require installation of a flap gate or control

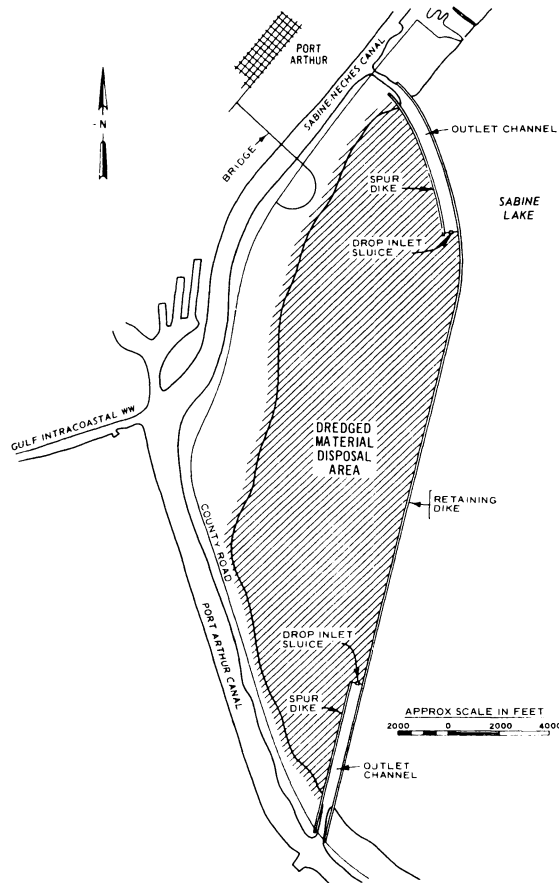

Fig. 13. Plan of Sabine Lake south disposal area, dike, and outlet structures (Galveston District)

valve on the floodplain side of the sluice to prevent floodwaters from backing into the disposal area (fig. 14). A berm, or extra thickness of dike material, is often added near the sluice to withstand the pressures exerted by water ponded there and to prevent seepage along the sluice-dike contact. Oil skimmers may be installed in front of the weir across the sluice inlet to prevent the escape of floating pollutants (fig. 15).

Box sluice or flume

67. A box sluice or flume consists of a timber structure built through the dike section so that it interrupts the dike line (fig. 16). The timber floor of the sluice structure forms the spillway along which the effluent escapes after topping the stoplogs in the weir gate.



Fig. 14. Flood control valve on exterior side of sluice discharge pipe

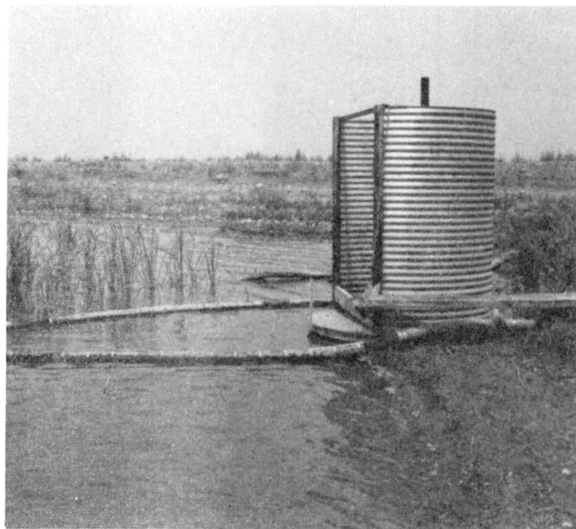

Fig. 15. Oil skimmer (floating tube-shaped device) in place with corrugated metal pipe and riser sluice

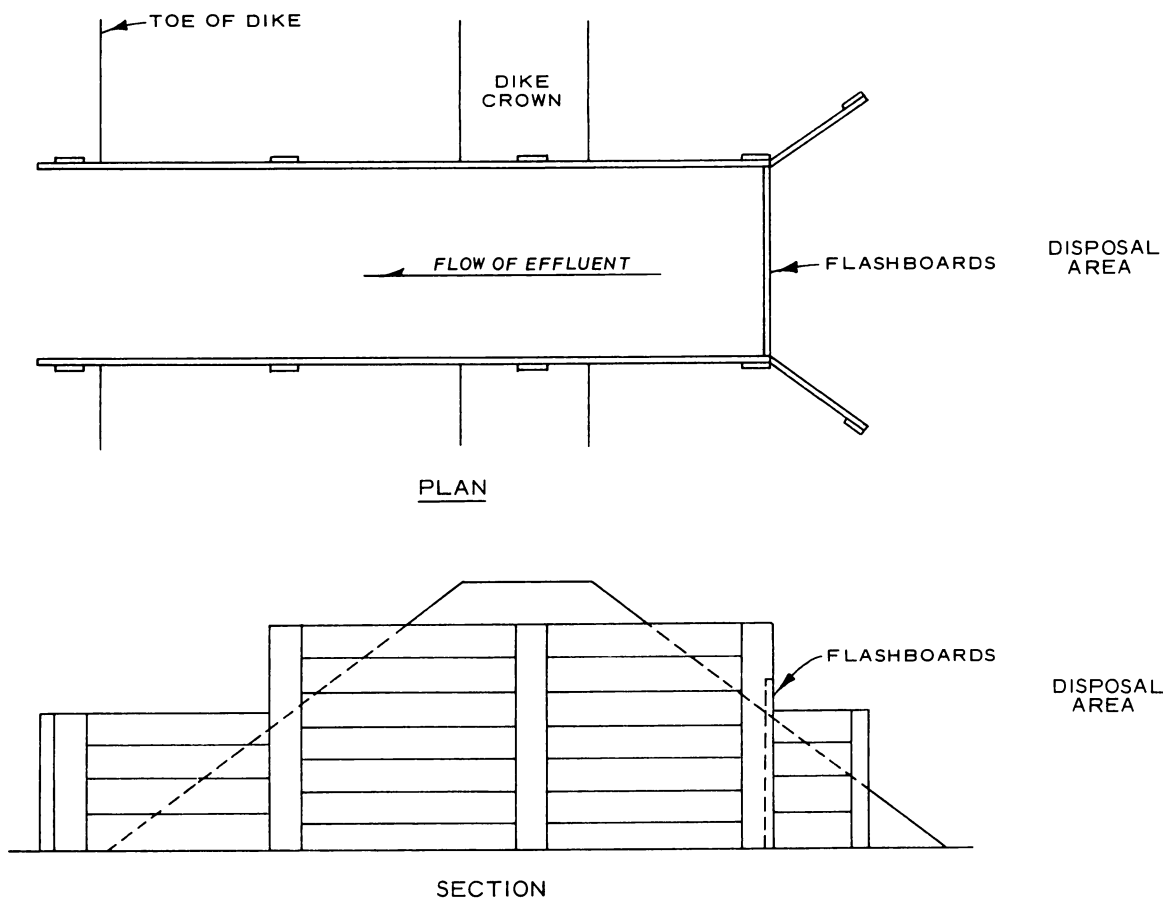

Fig. 16. Box sluice or flume (reproduced, with modification, with permission from Hydraulic Dredging,¹² by John Huston, Copyright 1970, by Cornell Maritime Press, Inc., Cambridge, Md.)

Because this type of sluice takes the place of part of the dike section, it represents a point of weakness, and dike failures are possible if seepage is allowed to progress along the sluice-dike contact or through a rotting sluice. Rotting box sluices were blamed in a dike failure at one large CE-operated containment facility (see paragraph 209). Box sluices are seldom used in CE operations.

Dike filter

68. A filter may be substituted for a sluice in the draining of containment facility effluent. The filter medium may take the form of the dike material itself, or a separate filter structure may be installed in a section of the dike.

69. Dike fill. The Buffalo District has constructed four dredged material containment dikes as part of its role in the Great Lakes pilot program. All four dikes rely on the filtration of effluent through the body of the dike and, in two of them, through an additional filter blanket. Dikes for the two areas in Cleveland Harbor are stone-fill structures protected by a layer of riprap on the exterior face and lined with a 7-ft-thick stone filter blanket. The two areas in Buffalo Harbor are diked by slag-filled structures. Solids are removed from the effluent as it passes through the slag body of the dike. Design and construction of these dikes are discussed in Part IV.

70. Water quality measurements have been reported for only one site (Buffalo Harbor pilot site). The measurements indicate tentatively that there is no significant difference in quality (EPA criteria) between water inside the disposal area dikes and that immediately outside in the harbor. The facilities have been in operation for from 2 to 5 yr. All of the structures have been successful in allowing water to drain from the disposal areas. No difficulty has been encountered from clogging of the pores of the stone, slag-fill, or filter blankets.

71. Filter cloth. A prefabricated wooden A-frame structure lined with a permeable plastic filter cloth has been investigated by the Charleston District to determine its suitability as a dredged material retention and effluent-filtering device to be used in disposal areas considered too wet for conventional dragline construction. Testing consisted of erecting a 3- to 6-ft-high wooden A-frame dike enclosing an area within a larger earth-filled retention dike for part of the Atlantic Intracoastal Waterway dredging operations. The dredged material was an organic silt. The coarsest filter cloth used had a mesh equivalent to a No. 40 U. S. Standard sieve size (fine sand size, about 0.4 mm). The dredging contractor was to discharge into the A-frame diked area until it became full, at which time he would discharge in an area away from the test areas to allow the effluent time to drain through the filter cloth. During the early stages of disposal, visually clear effluent seeped very slowly through the cloth under a head of about 2 ft created

by the difference in interior and exterior dredged slurry levels. The test area filled rapidly, and the contractor inadvertently was allowed to fill the exterior earth-diked area, thereby eliminating the pressure head and forcing an end to the test. Tentative results indicate, however, that the method may be worthwhile, particularly if a larger mesh size, compatible both with rapid drain-off of effluent and with retention of solids, is used. Construction costs of \$4 or \$5 per foot of dike reportedly are comparable to costs for earth dikes constructed in similar marsh terrains.

72. Vertical sand filter. The proposed steel sheet pile-rubble mound retaining dike at Milwaukee Harbor, Wisconsin, will have a vertical sand filter for drain-off of effluent. Four contiguous 50-ft-diam filter cells will constitute part of the dike on the lake side of the containment facility. Fig. 17 shows the containment facility and filter cell

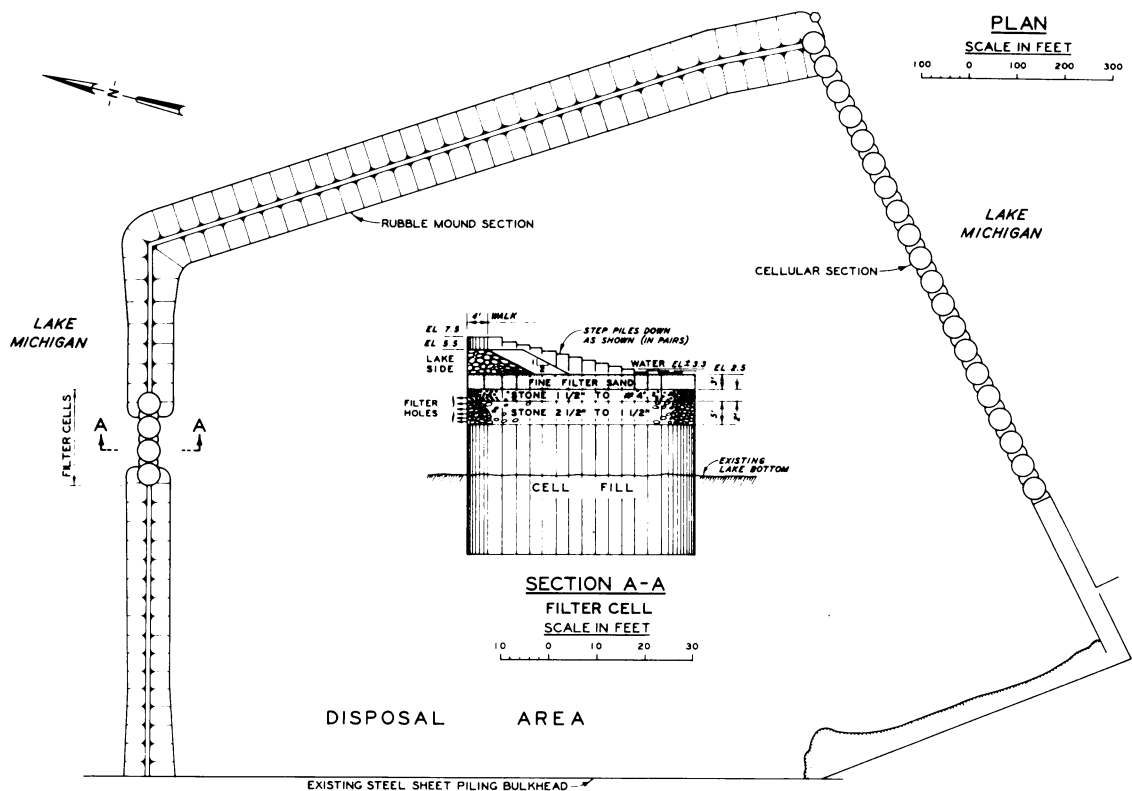

Fig. 17. Dredged material containment facility proposed for Milwaukee Harbor, Wisconsin. Vertical sand drain filter cell shown in Section A-A

locations in plan and one cell in section. Water enters the filter cells from the interior and exits into the lake waters through drain holes in the exterior of the cell after falling through three layers of graded filter sand and stone. Filter material will be removed about once a year and replaced. The Chicago District based the design of the filter on sewage treatment facility design. The dredged material is expected to be organic, fine-grained harbor sediments.

Containment Facility Operation

Problems and considerations

73. Retention of solids and pollutants. The principal functions of a dredged material containment facility are the retention of solid particles and the release of pollutant-free effluent back to natural waters. Dredged material slurry usually contains between 10 and 20 percent solids by weight as it is discharged into the disposal area. Slurry densities corresponding to these solids contents are 1066 and 1142 g/l, respectively, if a specific gravity of 2.65 of solids is assumed (see fig. 18). The Philadelphia District⁴ stated that the average pumped density of dredged slurry in pipeline dredges rarely exceeds 1150 g/l (about 21 percent solids), and the Mobile District reported¹⁷ that dredges normally pump 12 to 15 percent solids (1080 to 1103 g/l) in long pipelines. Presumably, slightly higher percentages would be expected in shorter lines. Requirements for disposal area effluent reentering channels vary considerably from State to State, but the values of 8 g/l and 13 g/l (above ambient densities) are often used as guidelines for meeting water quality requirements. Ambient water conditions in the Philadelphia District were reported at approximately 1004 g/l. Sacramento District measured ambient water for total solids in several dredging areas and recorded densities equivalent to 1004 g/l for a silty, brackish-water bay channel and 1000.3 g/l for predominantly sandy freshwater river channels.^{18,19} To meet an 8 g/l above-ambient effluent requirement, therefore, the density of the slurry entering and then leaving the disposal area must be decreased from say 1150 to

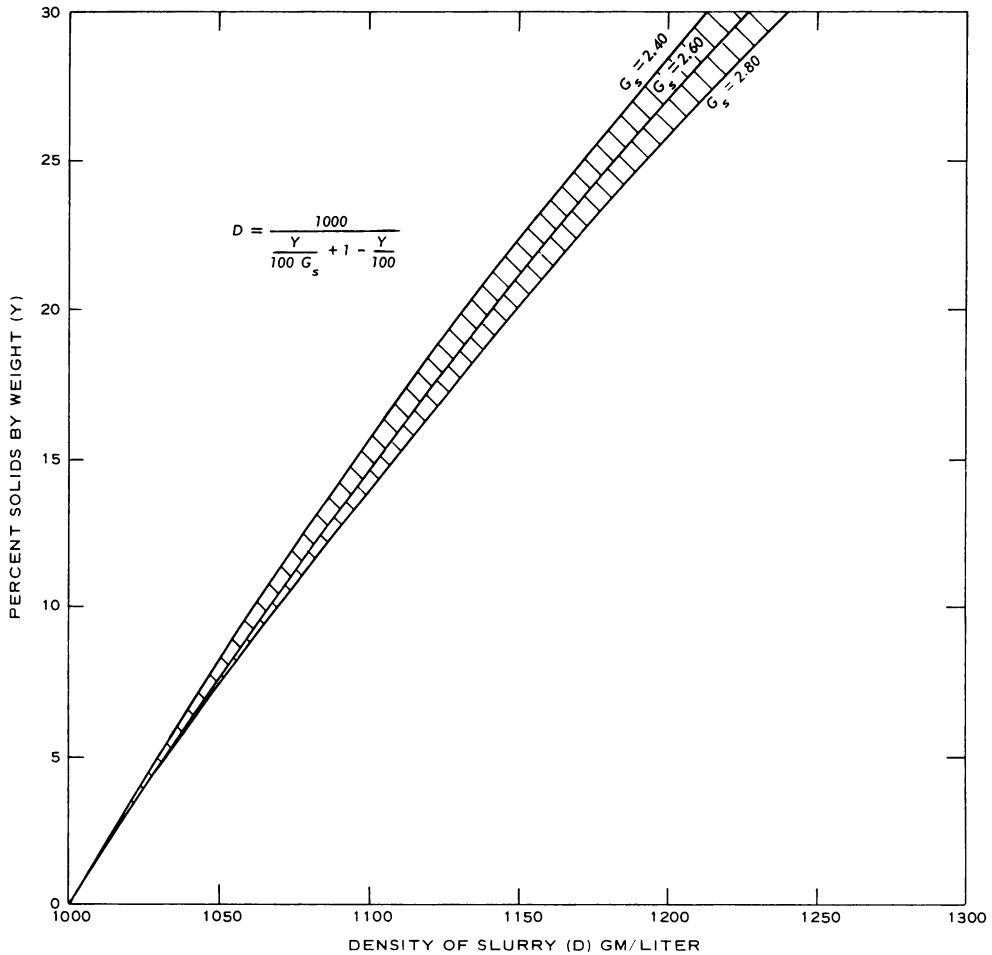

Fig. 18. Graph relating percent solids by weight in slurry to density of slurry in grams per liter at specific gravities of solids G_s of 2.40 to 2.80. Generally, the lower G_s applies to organic material, the midrange G_s to silt and sand, and the upper G_s to clays

1004 g/l plus 8 g/l, or 1012 g/l (2 percent solids). In other words, with 21 percent solids entering the disposal area and no more than 2 percent solids allowed over the sluice, an efficiency of 19/21 or 90.5 percent is required to meet the effluent quality criterion of 8 g/l above ambient. The value of 1150 g/l or 21 percent solids for density of slurry carried to the disposal area is high; a value of 1080 g/l or 12 percent solids is probably more representative of the majority of dredged material in disposal operations. This value would indicate an

efficiency of 10/12 or about 83 percent required to meet effluent standards of 8 g/l. Other standards are also used for evaluating effluent quality, and these will be discussed later. The 8 g/l parameter was used here to afford some estimation of the efficiencies required of a containment facility in meeting such a standard.

74. The objective reporting of dike problems and containment facility operation of the McDuffie Island disposal area, Mobile Harbor, by Mobile District in 1970 offers useful examples of some of the problems encountered in such operations and of the efficiency that might be expected.¹⁷ The disposal area, shown in fig. 19, is located on the south



Fig. 19. McDuffie Island disposal area
(Mobile District)

end of McDuffie Island and encloses about 130 acres at an average elevation (after completion) of about 6.5 ft msl. The area had been used previously for unconfined disposal of very fine silt. Retaining dike configuration, construction, and stability problems of this facility are discussed in Part IV. Drop-board weirs were installed and ponding was achieved over two-thirds of the area as the dikes were raised. The maximum initial pond depth of 3 ft decreased as the area filled, with an average of 2.5 ft of ponding maintained. A 27-in. pipeline dredge was

used at first but was replaced with a 24-in. pipeline dredge to allow longer detention times. Operational difficulties, such as channelization of the dredged slurry from the point of discharge to the sluice and insufficient ponding depth, resulted in excessive amounts of solids leaving the area at the sluice. The contractor had to raise the dikes repeatedly and was forced to pump only 6 hr at a time and stand by for 6 hr while the material settled in the disposal area. Frequent dike failures resulted in a loss of approximately 31 percent of the material placed in the disposal area. The loss of material through breaches in the dike affected the recorded efficiency of dredged slurry retention as measured at the sluice discharge, but an indication of effectiveness nevertheless can be obtained by comparing percent solids passing the sluice with percent solids entering the disposal facility through the discharge pipe. With an average of 11.9 percent solids entering the disposal facility, a mean of 2.9 percent solids exited at the sluice for an efficiency of 75 percent in retention of solids.

75. Water quality samples taken at the dredge discharge and at the sluice discharge for operations in Sacramento District indicate efficiencies obtained from a moderate size disposal area in which predominantly sandy material was deposited.¹⁸ Dredgings from Stockton Port and Stockton Channel were deposited in a 138-acre diked disposal area. Efficiencies for these operations were generally above 99 percent, comparing total solids at the end of the dredge discharge pipe with the total solids in the disposal area effluent (see results for samples 1-6 in the tabulation on page 49). Samples taken similarly in a reach of Suisun Bay, a salt- and brackish-water area yielding primarily silt and finer material, showed an efficiency for one disposal area of 94 percent (sample 7).¹⁹ Other requirements must often be considered before the effluent is judged acceptable.

76. These two examples (Mobile and Sacramento Districts) are not intended to be representative of the efficiencies to be expected from the typical dredged material containment facility; insufficient data were collected to make such a representation. The examples are intended only to show some of the quantities dealt with in operating a disposal

<u>Dredging Location</u>	<u>Predominant Material</u>	<u>Sample Identification</u>		<u>Total Solids g/l</u>
		<u>Number</u>	<u>Location</u>	
Stockton Port and Channel ¹⁸	Sand	1	Dredge discharge	129.32
			Disposal area effluent	0.62
		2	Dredge discharge	89.25
			Disposal area effluent	0.77
		3	Dredge discharge	82.99
			Disposal area effluent	0.50
Suisun Bay ¹⁹	Silt and finer	4	Dredge discharge	27.20
			Disposal area effluent	0.51
		5	Dredge discharge	54.63
			Disposal area effluent	0.49
		6	Dredge discharge	45.87
			Disposal area effluent	0.71
		7	Dredge discharge	364.50
			Disposal area effluent	23.28

area for the extraction of solids from the slurry. Investigations conducted to determine effectiveness of diked areas in retaining solids and pollutants were conducted in the Great Lakes.²⁰ These studies (vol 2 of reference 20) should be consulted for more comprehensive data concerning water quality improvements by confining of dredged material.

77. Channelization. Channelization is the short circuiting of the movement of dredged slurry from the dredge discharge to the sluice. It results in decreased detention time and, subsequently, less removal of settleable materials from the effluent. It is commonly caused by either too steep a gradient between the discharge point and the sluice, which is brought about usually by mounding of coarser material near the discharge pipe, or by placement of the discharge pipe too near the sluice. In the latter situation only a small portion of the containment area is actually used by incoming slurry. It is probably the most common cause of channelization, and contract specifications are often written to prevent improper placement of the discharge pipe with respect to the sluice. Channelization at the McDuffie Island, Mobile Harbor, test site was attributed to the slope of the disposal area (gradient) toward the sluice and insufficient pond depth. Fig. 20 shows a prominent flow line



Fig. 20. View of McDuffie Island disposal area during disposal operations. Prominent channelized flow extends from dredge discharge point in upper center to sluice, off picture in lower center (Mobile District)

carrying the incoming dredged material directly to the sluice in the McDuffie Island site. Inspection of fig. 20 indicates further that placement of the discharge point too near the sluice apparently aided in short circuiting the flow. Similar problems were reported at the Terminal 4 disposal site, Portland Harbor (Portland District).²¹ Placement of the discharge pipe too near the sluices, in this case in adjacent sides, was blamed for channelization and the resultant decreased detention time.

78. A limited amount of channelization may be desirable in disposal areas of irregular topography, or where coarse material builds up near the dredge discharge point, to keep the dredged slurry moving away from the discharge point and into the disposal area. However, disposal crews should watch for unpredictable shifts in the channel. Preventive measures for channelization are discussed below.

79. Wind. The effects of wind on containment facility operation can be both beneficial and adverse. High winds on waters that allow a high amount of fetch produce waves damaging to exterior slopes of

containment facilities built offshore. Interior waves set up by winds blowing across ponded water in a large disposal area can similarly affect interior dike slopes. These aspects of dike instabilities are discussed in Part IV. Disposal areas situated in semiarid regions of the country experience appreciable drying of the surface of the dredged slurry and consequently may experience problems from blowing dust and sand. Disposal sites in the Corpus Christi, Texas, area (Galveston District) have been particularly susceptible to this phenomenon. The dredged material is usually clay-size with a high salt content. Southeast winds deposit the salt-laden dust inland over crops, which results in damages. Sacramento District experienced problems with blowing sand on one of its Sacramento River Deep Draft Ship Channel disposal sites. Attempts at controlling wind erosion by seeding and topping with clay have met with little success there.

80. Wind direction may determine whether its effects are beneficial or adverse to operations. The two sluices for the north Blakely Island site at Mobile Harbor (Mobile District) were installed on the northwest side of this diked facility. A north wind aided operational efficiency by blowing the turbid slurry away from the sluice, allowing more time for the extraction of relatively clean water at the weir. A southerly wind, on the other hand, concentrated dredged slurry against the sluice and hindered its operation. The wind also agitated the slurry and caused more solid particles to stay in suspension. If a particular wind direction predominates, sluices should perhaps be located to take advantage of its beneficial effects, if such location is compatible with dredge discharge locations with regard to channelization.

81. Mounding of dredged material. In most dredging operations, some coarse material may be present ranging from sand to clay balls to boulders or bricks. This material rapidly falls out of suspension near the end of the dredge discharge pipe and, if large quantities are present, forms mounds of material that can hinder movement of the slurry toward the sluice, decrease containment area capacity, and lessen ponding area. The Jacksonville District, for example, dredges large quantities of sand in many of its operations. Its Alafia River Channel,

Tampa Bay, disposal site is characterized by relatively high dikes necessitated by the mounding of silty and sandy dredged material within the disposal area and a resulting decrease in storage capacity (fig. 21).

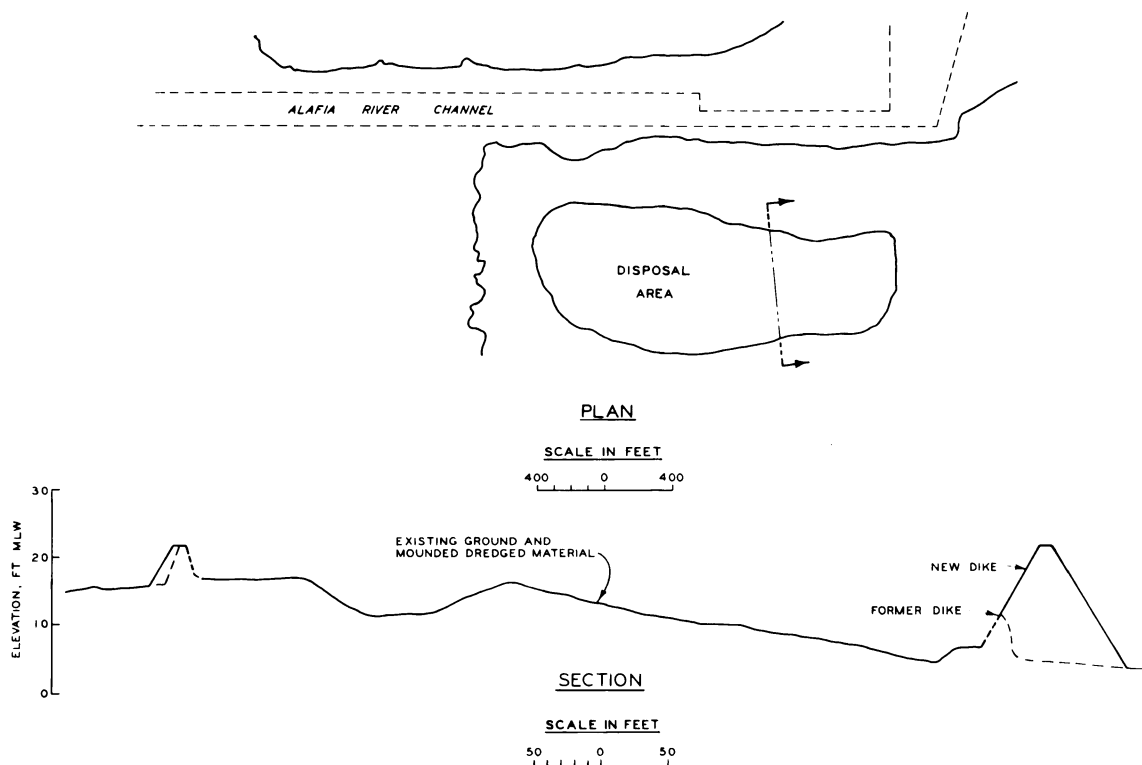

Fig. 21. Alafia River Channel disposal area, Tampa Bay (Jacksonville District)

Sandy dredged material reportedly assumes a slope of 1V on 10H to 1V on 5H, whereas silty material usually assumes 1V on 30H slopes.

82. A similar situation exists for disposal sites along the Atlantic Intracoastal Waterway in Wilmington District, except that the naturally irregular topography is responsible for decreased capacity. The District recommends reworking and flattening the disposal area before diking to increase the area's effectiveness. Mounding of material at one end of the large Eagle Island disposal area (Wilmington Harbor, North Carolina) creates two effects on operations there. First, about one-half of the facility is not usable because mounds of dredged material have cut off access of the incoming slurry to the sluice.

Second, in other portions of the site, the slope created by the high ground channels runoff from heavy rains directly to the sluice where it endangers the dike slopes.

83. Although it may be economically or operationally impossible to level the topography of a disposal site before filling, it may be feasible to do this after partial filling. After a year or so of settlement and drainage, particularly of sandy dredged material, it may be possible to redistribute the material from mounded areas to lower areas with land grading equipment. Some redistribution could possibly be accomplished during the dredging operation using specially equipped all-terrain vehicles.

Increasing containment facility efficiency

84. Many methods have been used by CE Districts to improve the effectiveness, stability, or aesthetic qualities of dredged material containment facilities. The techniques discussed below have been variously instituted to enhance the ability of the disposal facility to achieve its primary goal of removing and retaining wastes from the effluent water.

85. Cross dikes. A cross or lateral dike is sometimes placed across the interior of a containment area to connect the retaining dike on one side to that on the other. The cross dike is usually placed between the dredge discharge point and the sluice so that the slurry is subjected to initial settling in one section before passing over or through the cross dike to the next section. The cross dike may also be used with a "Y" discharge line to break an area up into two areas, each receiving half of the incoming dredged material. Cross dikes are sometimes placed across an area in which elevation increases toward one end to allow material in the higher part to pond before spilling over into the lower part and out through the sluice. Cross diking is used to some extent by most of the CE Districts contacted during this study.

86. Alternating disposal areas. Two or more disposal areas may be used alternately in a dredge disposal operation to allow more settling time. The dredge normally pumps into one area until the allowable

freeboard is reached and then pumps into another area while the slurry in the first settles out. This method was used with some success for the 1972 dredging of the Mobile River channel, Mobile Harbor, Alabama. Initially, two disposal areas on opposite sides of the channel were used interchangeably by filling through submerged pipelines leading from a pipeline dredge. Dike instability problems necessitated more frequent alternation of areas than planned, but the availability of two areas allowed dike repairs to be made in one area while disposal continued in the other area. Two additional areas were eventually added to the operations because the initial two areas filled quickly and caused the dredge to shut down occasionally while waiting for the two areas to drain. The four-area system was apparently effective in spite of frequent dike sloughage problems in some of the disposal areas.

87. Spur dikes. Spur or finger dikes protrude out into, but not completely across, the disposal area from the main dike. They are most commonly installed to prevent channelization by breaking up a preferred flow path and dispersing the flow out into the disposal area. Spur dikes are also used to allow simultaneous discharge by two or more dredges at large facilities like the Craney Island site (see fig. 10). The parallel spur dikes prevent coalescing of the two dredged material inputs and thereby discourage an otherwise large quantity of slurry from reaching flow velocities necessary for channelization. The frontispiece of this report is an infrared aerial photo of Craney Island. The spur dikes on the northeast leg separate three discharge points: the upper is used for pipeline dredge discharge, the center is for direct pumpout of hopper dredges, and the lower is for pumpout of the rehandling basin and for other pipeline discharges. Some channelized flow lines are visible, but apparently the large size of the area (2500 acres) and the placement of the spur dikes disperse the flow lines and allow development of a pond sufficient for settling of solids.

88. Interior drainage ditches. If channelization is expected to occur, drainage ditches may be excavated to direct dredged slurry flow in a circuitous route from the discharge point to the sluice. Some settling time is gained by this, and short circuiting by channelization

is prevented or at least delayed. Ditches are, in effect, routes of channelization, however, and probably should be used only if dispersion of dredged slurry and adequate ponding cannot be achieved by other means.

89. Vegetation. Grasses, weeds, and other rooted vegetation reportedly aid in filtering solid matter from the dredged slurry, deter channelization by decreasing velocity of flow, and decrease agitation of the slurry by wind. Growth in disposal areas is encouraged when time permits, but frequency of disposal operations often prevents development of vegetation.

90. Energy dissipaters. Material entering a disposal area through a dredge discharge line may possess enough energy to scour material in the discharge vicinity and thereby erode interior slopes of dikes or initiate gullies of channelized flow. Energy dissipaters in the form of splash plates or "Y" joints are sometimes installed on the disposal area end of the discharge pipe to prevent such occurrences. The sudden loss of energy by the slurry also encourages settling of particles. However, since this promotes buildup of material at the point of discharge, some scour of the discharge area is probably desirable because it helps carry material farther into the disposal area.

91. Weir crest length. There is a probable correlation between the length of weir crest over which effluent escapes and the turbidity of the effluent. An increased weir length decreases the head over the weir and permits more selective withdrawal of the upper, cleaner portion of the slurry as effluent. The more rapidly dredged material is pumped into a disposal area, the greater must be the weir length available to maintain a given head. Some CE dredging contract specifications state minimum weir crest lengths and numbers of sluices required for different dredge pipeline diameters. Values of crest length as low as three and four times the pipeline diameter are being required. The Jacksonville District uses the following tabulation of accepted dimensions in its specifications:

Discharge Pipeline Diameter <u>in.</u>	Total Weir Crest Length <u>ft</u>	No. of <u>Sluices</u>
30	58	6
27	47	5
24	37	4
20	25	3
18	20	3
16	16	2
14	12	2
12	10	2

The values of weir crest length were determined by application of a hydraulic flow formula.¹² The values used have reportedly worked satisfactorily for the District. Norfolk District lists roughly similar guidelines in their dredging specifications as follows:

Minimum waste weir requirements: 8- to 12-in. pipelines, one 16-ft-wide spillway; 14- to 18-in. pipelines, one 28-ft-wide spillway or two 14-ft-wide spillways.

Norfolk District's values are based on experience with meeting effluent quality requirements of 13 g/l above ambient in previous dredged material disposal operations. They are merely guidelines and are sometimes altered to fit the conditions of a particular contract.

92. Filter fences. One case was reported in which a dredging contractor attempted to filter the slurry just before it entered the sluice. He erected two concentric burlap fences 100 ft apart in front of the sluice. The filtration was effective until the burlap became clogged and prevented further movement of material to the sluice. This method is similar in principle to the plastic filter cloth dike discussed earlier.

93. Flocculants. An increasing amount of testing is being done to determine the effectiveness of chemical flocculating agents in removing pollutants and solids from dredged material in both bottom dumping hopper dredge operations and in confined disposal operations. Tests at a Toledo, Ohio, disposal area²⁰ of a final clarification basin within a 30-acre confined disposal site for treatment of dredged material with

organic flocculants showed that dredged slurry entering the clarification basin could be effectively clarified with 4 to 8 ppm of a particular flocculant if the suspended solids level of the slurry did not exceed 11 g/l. This level represents a suspended solids content of only 1.1 percent before clarification (assuming G_s of 2.65). As discussed earlier, water with 2 percent solids is usually acceptable as effluent in meeting an 8 g/l above ambient effluent requirement. This effluent would require no further clarification in many instances, and the effectiveness of the flocculation in the clarification basin is therefore questionable. Presumably, only dredged material with a relatively low suspended solids content can be effectively clarified with flocculants. Flocculation experiments by Galveston District revealed that dredged slurry in confined areas is so dense that, for flocculation to be effective, the necessary dilution of the slurry would make the operations impractical. Galveston District concluded that flocculation is practical only for dredged material with low solids content. Some Districts, however, have adopted or are required to meet much more severe effluent standards, such as 5 to 10 Jackson Turbidity Units (JTU) or a solids content of a few parts per million, and these would probably require extensive clarification of the runoff before it left the facility. Flocculation might be warranted and applicable in these situations.

94. The Seattle District is investigating the effectiveness of flocculants and extended weir crest lengths in reducing turbidity in the effluent from the Willapa Harbor confined disposal site. Initial results have shown improvement of effluent turbidity values passing a 50-ft weir when flocculants are used, but the data are too incomplete to establish significant change. A report of these and other variables studied is forthcoming from the Seattle District.

95. Ponding, detention time, and freeboard. Discussions with the various CE Districts indicate that, as filling of a containment facility progresses by settling of solid particles, the efficiency of the facility is reduced. It is uncertain at this time which of the factors of pond depth, ponding time, or detention time most greatly affect

efficiency of the containment facility, nor are the interrelationships of the three factors understood.

96. Jacksonville District operates one of its containment facilities on the basis of 10 to 12 hr ponding time, i.e. the sluice is closed for 10 to 12 hr after disposal operations cease. The District hopes to establish a correlation between channel sediment settleability and dredged slurry settleability so that the required ponding time can be specified for a given material and disposal area. Wilmington District plans to monitor the new disposal area for the Military Ocean Terminal at Sunny Point, North Carolina, for dredged material settlement characteristics to establish detention times for subsequent disposal operations. Buffalo District stipulated a minimum pool surface area of 300,000 sq ft and a maximum dredged slurry pumping duration of 16 hr per day for its Wilson Harbor disposal area. Many Districts require the contractor to cease pumping operations in the event of a dike failure or pipeline leak. Some extend the requirement to include situations in which criteria for effluent, freeboard, or ponding are not upheld. At least 2 ft of freeboard is usually required. This shutdown clause is one way of avoiding difficulties or conditions over which the District has little control because of inadequate research and data on the subject.

97. Dredge pipeline size and location. Dredge discharge pipes used in CE operations range generally from 8 to 36 in. in diameter. Disposal area efficiency and stability are decreased with the use of a discharge pipe that is too large for a given area. The volume of material entering the containment facility in a given amount of time (discharge rate) increases rapidly with increased pipe diameter. The following tabulation lists the discharge rates for various pipeline diameters for a flow velocity of 12 ft/sec. CE districts usually do not have control over the size of dredge used, but the data in this tabulation can be used to determine how fast a disposal area will fill and thereby will provide an indication of allowable pumping time.

98. The location of the discharge end of the pipeline within the disposal area with respect to the sluice location and to the dike slopes

Discharge Pipeline Diameter in.	Discharge Rate (for Flow Velocity of 12 ft/sec)*	
	cu ft/sec	gal/min
8	4.2	1,880
10	6.5	2,910
12	9.4	4,220
14	12.8	5,750
16	16.5	7,400
18	21.2	9,510
20	26.2	11,740
24	37.7	16,890
27	47.6	21,300
28	51.3	23,000
30	58.9	26,400
36	84.9	38,000

* To obtain discharge rates for other velocities, multiply the discharge rate shown in this tabulation by the velocity and divide by 12.

is important. Turbulence of the incoming dredged material causes high turbidity in the vicinity of the discharge. The interior slope of the dike may be scoured by the discharged slurry if the discharge pipe is not extended far enough beyond the dike. Dike scouring is discussed in Part IV. On rare occasions, dredging contract specifications indicate where the discharge pipe is to be placed. A distance from the dike slopes may be specified, or the exact discharge point may be delineated on the contract drawing. Discharge location is difficult to control for a disposal area located adjacent to the channel being dredged because in that situation the dredge pipe is usually placed in the disposal area at the point nearest the position occupied by the dredge at the time.

Odor Control

99. Materials deposited in a disposal area sometimes produce mal-odorous gases released by the agitation of organic and other chemical constituents within the dredged material. The proximity of residential or other densely populated areas then requires the implementation of

some form of odor control or abatement. Chicago District investigated several information sources in an effort to gather data on abatement of odors in dredged material.²² The investigation yielded very little information for direct application to odor control in dredged material disposal operations. The report stated that: (a) Odors are usually emitted immediately upon placement of the dredged material in the disposal area and may continue for over a year; (b) Highly organic dredged material becomes malodorous if insufficient oxygen is present to satisfy the biochemical oxygen demand; (c) Inorganic dredged materials do not generally cause odor problems; (d) The distance to which a dredged material odor would be dispersed has not been measured or estimated; and (e) Cityl alcohol, sodium nitrate, and potassium nitrate are masking agents suggested for possible application to dredged materials. The investigations of one chemical company show, however, that the effectiveness of masking agents is temporary and that they may produce by-products harmful to man and animals.

100. A more definite approach to odor abatement is being made by the Galveston District on maintenance dredging for the Houston Ship Channel. The environmental impact statement for this project²³ describes procedures to be implemented in deodorizing the dredged sediments at the disposal site. A chemical consisting of essential oils, deodorized kerosene, and an emulsifier was recommended for the task. This product has been used successfully on previous maintenance dredging projects, has produced no apparent adverse side effects, and contains chemicals approved by the U. S. Department of Agriculture (USDA).

101. A special effort was made in 1971 at the Clinton disposal area of the Houston Ship Channel project to reduce the odor of raw sewage emitted by dredged material deposited there. Two methods were used in lessening the odors: (a) introduction of a deodorant into the disposal area, and (b) use of constricted sluices. The sluices (fig. 22) were designed to prevent agitation and mixing of the dredged material effluent and thus reduce the emission of odors.

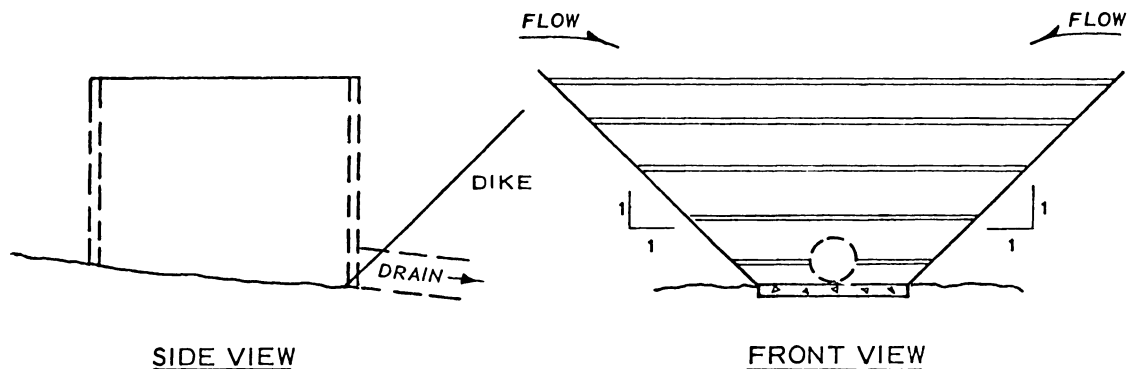

Fig. 22. Sluice designed for control of dredged material odors (Galveston District)

Mosquito Control

102. Several Districts require disposal areas to be drained at completion of disposal operations to prevent ponding conducive to the breeding of mosquitoes. Savannah District, however, requires areas to remain fully ponded during and between disposal operations to deter breeding of a particular type of mosquito (*Aedes sollicitans* or the Jersey mosquito). This mosquito breeds deep in the desiccation cracks formed when a fine-grained dredged material is allowed to dry out. The mosquito reportedly lays its eggs within the cracks where they remain dormant for as long as 6 yr until water again is introduced into the area, allowing the eggs to hatch. This variety of mosquito was apparently first noticed in New Jersey and has spread down the east coast. The USDA in Savannah has been conducting research on the habits of the mosquito and recommends the ponding of the disposal areas.

103. The Galveston District carries out a program of aerial spraying for control of mosquitos in dredged material disposal areas. The program is intended primarily for the heavily populated Houston Ship

Channel area where numerous disposal sites are of necessity placed adjacent to residential and industrial areas.

Disposal Area Effluent Requirements

Effluent standards

104. Effluent quality standards used by CE Districts are either State imposed or voluntarily imposed by the District itself. No Federal standards currently exist. The selection of effluent standards to be adopted is often difficult because of the apparent lack of guidance offered by the EPA and the many different parameters available for measuring effluent quality. These parameters are density in grams per liter; turbidity (usually a measurement of light transmission in JTU's); settleable solids in parts per million; and settleability of solids in milliliters per liter per hour measured with an Imhoff cone. Density standards are the most commonly used parameter by the CE Districts contacted in this study. The following tabulation lists the effluent quality standards currently used by the Districts.

<u>District</u>	<u>Effluent Standard Used</u>	<u>District</u>	<u>Effluent Standard Used</u>
Galveston	8 g/l above ambient	Philadelphia	8 g/l above ambient
New Orleans	None set	New York	8 g/l above ambient
Mobile	None set	Buffalo	50 ppm settleable solids (subject to change)
Jacksonville	50 JTU's	Detroit	8 g/l above ambient
Savannah	None set	Chicago	None set
Charleston	None set	Sacramento	8 g/l above ambient
Wilmington	50 JTU's	Portland	5 JTU's
Norfolk	13 g/l above ambient	Seattle	5 to 10 JTU's

105. Separate attempts are being made by the various Districts in determining which parameters are most meaningful in their particular situations. Philadelphia District has tightened its restriction from 13 g/l to 8 g/l because it feels that the lower requirement can be

achieved. Buffalo District, however, feels that the 8 to 13 g/l value is too lenient and that the 50 ppm settleable solids standard is technically and economically feasible.

106. Confusion has resulted when a double standard has been applied by a State agency. For example, Sacramento District has adopted the State of California's general effluent requirement based on density. An order handed down by the California Regional Water Quality Control Board for a dredging job by the Division of Highways, however, specified in part that "...discharge (into the Sacramento River) shall not contain settleable solids in excess of 0.2 ml/l...[and]...shall not cause the turbidity of the Sacramento River to increase by more than 10 percent above the background level."²⁴ Such variation adds to the difficulty of deciding which standards should be adopted.

Monitoring programs

107. Effluent monitoring techniques, sample locations, and frequency are generally specified as a contractor responsibility by those CE Districts applying empirical quality standards. Three Gulf Coast Districts currently monitor the effluent at the sluice by visual inspection or by visual comparison of the effluent with a jar sample of standard quality. Monitoring for these Districts is performed by CE personnel although the county health officer monitors the many Houston Ship Channel disposal areas of Galveston District.

108. Some of the dredging contracts let by Jacksonville District include a separate section in the technical provisions entitled "Disposal Area Monitoring." This section specifies that turbidity and pollution samples are to be taken before and during dredged material discharge and states where and at what intervals the samples are to be taken. The contractor may measure the turbidity with an acceptable on-board unit but must have the pollution samples tested by a reputable laboratory. Turbidity samples are taken at the sluice, at the end of the runoff ditch, and in the channel to which the effluent is returned.

109. The Norfolk, Philadelphia, and New York Districts include a subsection in the dredging specifications for the "Control of Disposal Area Effluent." The contractor is required to take effluent density

samples at the sluice and upstream from the dredge during specified conditions of discharge, effluent density increase, and tidal fluctuations. The contractor may determine the density with a hydrometer if settled solids are not present in the sample, or by the weight per volume method if settled solids are present. Specifications for the Sacramento District are somewhat similar but require the samples to be taken only at the points at which the disposal area effluent enters the channel.

PART IV: RETAINING DIKE DESIGN, CONSTRUCTION,
AND STABILITY

110. Retaining dikes for confined disposal facilities are usually earth embankments constructed on lowland areas or nearshore islands. A few in-water containment facilities have been constructed, and in certain cases rock fill or slag has been used. Earth-filled cellular and double-steel sheet pile structures have been proposed for construction of in-water containment facilities (see Parts II and III). Retaining dike dimensions and composition vary and are largely dependent on foundation conditions and available construction materials. However, dike characteristics are also influenced by individual CE District policies regarding dike design and construction and available funding. In the past, most Districts left dike design and construction to the discretion of the dredging contractor. Damaging dike failures and encroachment on industrialized or populated areas have caused some Districts to take a more active role in retaining dike design and construction control. More recently, many retaining dikes have been designed based on detailed investigations and constructed to CE specifications. However, the majority of retaining dikes still receive little design consideration, and it is likely that the Districts' design efforts or construction controls will become more prevalent because of existing land shortages and environmental concerns.

111. Retaining dike construction is generally conducted either under a dredging contract or under a separate contract for dike construction let by the CE. In some instances a local interest such as a State port authority will furnish the dike. The most common practice is construction under the dredging contract, in which case the dredging contractor may be responsible for either dike design and construction or construction to CE specifications. These CE specifications may be detailed (specifying both construction methods and materials), or they may simply show minimum required dike dimensions. Dikes constructed under separate contracts are CE designed and are constructed to CE specifications. Separate dike construction contracts are generally used

only in special situations such as the construction of large containment facilities planned for use over a number of years.

112. The following discussion is devoted primarily to the design procedures, construction methods, costs, and behavior of typical retaining dikes. Contract specifications relating to dike design and construction are discussed, and size and composition of dikes are reviewed. Detailed descriptions of individual or groups of retaining dikes constructed within various CE Districts are presented in Appendixes A-D.

Description of Retaining Dikes

General features

113. The shapes, heights, and composition of retaining dikes are generally dictated by containment capacity requirements, local availability of construction materials, and prevailing foundation conditions. Many Districts are confronted with poor foundation soils at containment facility sites. Available sites are normally marginal lands not economically suitable for private development. Foundation soils are commonly natural deposits of soft clays and silts of various organic contents. In many instances, disposal sites have been used for past unconfined disposal, and the dikes must be constructed on previously deposited dredged material. Dredged material often consists of fine-grained wet materials of poor engineering quality. Low shear strengths of natural and dredged materials can limit initial dike construction to heights of only a few feet. Dikes of greater heights can be attained through construction of incremental dike sections, which are normally built a short time prior to disposal operations. As dikes are raised periodically, substantial heights can be achieved even on very weak foundations. This is due to a gain in shear strength of certain foundation soils as they drain and consolidate under loading of dredged material during periods of inactivity. Dike raising is usually accomplished by incorporating the initial dike into new dike construction (fig. 23a), although in some cases interior dikes are constructed at some distance from the inside toe of the existing dike (fig. 23b).

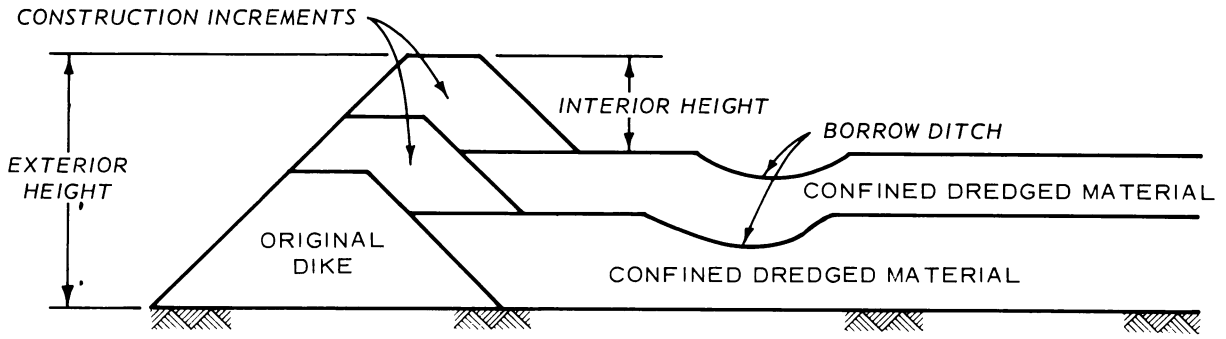

a. INCREMENTAL DIKE CONSTRUCTION

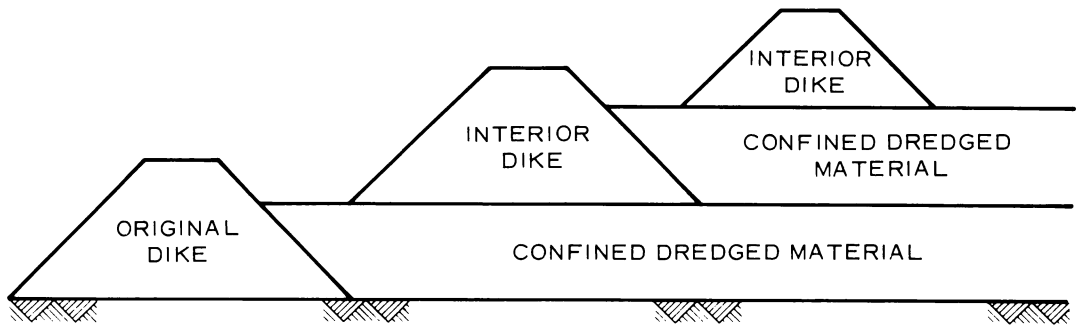

b. INTERIOR DIKES

Fig. 23. Dike raising methods

114. It is common practice to borrow materials from inside the disposal area (fig. 23a) for initial dike construction and for each dike raising because these materials are economical to obtain. Consequently, the quality of dredged material may greatly affect ultimate dike dimensions and stability in two ways since the dredged material can be both the foundation and the construction material. Because of the poor engineering quality of most dredged material, more suitable material has been borrowed in some instances from locations other than the disposal area.

Gulf Coast region

115. Generally, foundation conditions are extremely poor in the central and western Gulf Coastal area as many confined disposal sites are located in marsh areas. Natural deposits of peats, organic clays, and silts are common foundation soils. Perhaps the poorest dike foundations are encountered by the New Orleans District (A-1)* which presently confines more dredged material on land than any other CE district.¹ These poor foundation conditions generally limit maximum dike heights to 6 to 8 ft. Dikes in these areas are typically constructed of saturated silts and clays with a 4-ft crown width and 1V on 4H side slopes. In a few areas, silts and sands are the predominant foundation material, and through intermittent dike raising in 2- to 4-ft increments, exterior slope heights of 20 ft or better have been attained (Baton Rouge Harbor, Upper Calcasieu River and Pass).

116. Foundation conditions and retaining dikes in the Mobile District are similar to those in the New Orleans District. Dikes constructed of saturated silts and clays to heights of only a few feet are common. Only recently, due to special foundation preparation (see paragraph 172), a dike was constructed to a height of 10 to 12 ft with a crown width of 25 to 30 ft and 1V on 1.5H side slopes (C-10). The dike was constructed of sand obtained from a previous new-work dredging operation.

117. In the Galveston District, most dikes are initially constructed to heights of 4 to 5 ft with 4-ft crown widths and 1V on 3H side slopes. Dikes are then raised to 10 to 12 ft in 2- to 4-ft increments constructed at intervals of 3 to 4 yr (B-1). Marsh clays and dredged material of clays and silty sands are typical construction materials. Where foundation conditions are adequate and good construction materials are available, dike heights of 15 to 25 ft with 8-ft crown widths are often used (C-2, -3). Among the few in-water containment facilities utilized by the CE are the two adjacent containment areas constructed in Sabine Lake¹¹ by the Galveston District (D-1). The

* Refers to similarly numbered items in the Appendixes.

retaining dikes were constructed to heights of 10 to 12 ft in an average water depth of 5 ft. A typical section of the Sabine retaining dikes is shown in fig. 24. The crown width was 20 ft with a 1V on 6H interior

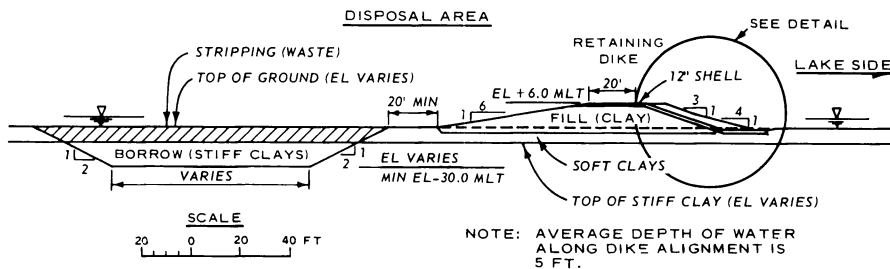

a. TYPICAL CROSS SECTION OF DIKE AND BORROW AREA

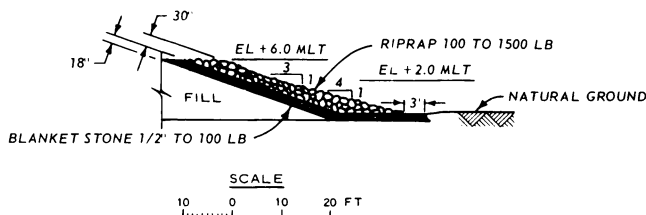

b. DETAILS OF EXTERIOR SLOPE PROTECTION

Fig. 24. Sabine Lake retaining dikes (Galveston District)

slope and 1V on 3H exterior slope. Construction material consisted of a stiff clay excavated from within the confined area. Exterior slopes were riprapped to provide protection from wave action.

Atlantic Coast region

118. Retaining dike dimensions vary widely among the containment facilities located along the east coast. In the Jacksonville District, retaining dikes are commonly constructed of sand on upland areas where good beach sand foundation soils are prevalent (B-6). Original construction to heights of 10 to 15 ft with crown widths of 10 ft and 1V on 2 or 3H side slopes is not unusual. Dike raising on previously constructed marsh-based containment facilities has been aided by the previous deposits of coarse-grained material. Dikes are generally raised in 3- to 10-ft increments with exterior slope heights limited to 20 to 25 ft.

119. Confined disposal facilities in the Savannah District (A-3)

are located primarily in marshes. Initial dike construction is generally limited to heights of 4 to 6 ft. Hydraulically placed sand has been used to establish a wide base foundation for dikes constructed to greater heights. Side slopes of 1V on 1.5 to 3.0H and base widths of 150 to 200 ft are common in hydraulic construction. Dikes are raised in construction increments of 4 to 6 ft with a crown width of 8 ft and 1V on 2H side slopes. Available dredged material is generally used in incremental construction.

120. The majority of retaining dikes constructed in the Charleston (B-2, -3; C-4, -5), Wilmington (A-4), and Norfolk District (A-5, C-7) areas are similar in size and composition. Foundation materials generally consist of dredged material underlain by soft marsh deposits. Silt and sand-sized material from within the disposal areas are used for dike construction. Initial construction and dike raising increments are usually limited to heights of 4 to 6 ft. Crown widths range from 4 to 10 ft and side slopes are approximately 1V on 1.5 to 2H. Exterior slope heights may reach a maximum 15 to 20 ft.

121. In the Charleston, Wilmington, and Norfolk Districts, there are a number of retaining dikes that have been constructed to heights somewhat greater than the average for these areas. Included are retaining dikes at the following locations: Daniel Island (D-2), Charleston District; Military Ocean Terminal at Sunny Point (C-6), Wilmington District; and Craney Island (D-3), Norfolk District.

122. The Daniel Island dikes²⁵ were constructed primarily of marl (sandy, calcareous clay) to a height of about 20 ft. Approximately 75 percent of the dike length is in water with a mean low depth of 8 ft. A typical cross section of a retaining dike at Daniel Island is shown in fig. 25. Side slopes are 1V on 2H above water and 1V on 4H below water. Slopes were riprapped where subjected to external wave action. The Daniel Island dikes have been raised 3 to 4 ft since initial construction (B-2).

123. Construction of a retaining dike for a confined disposal facility has recently been completed at the Military Ocean Terminal in Sunny Point, North Carolina (C-6). The dike traverses two main

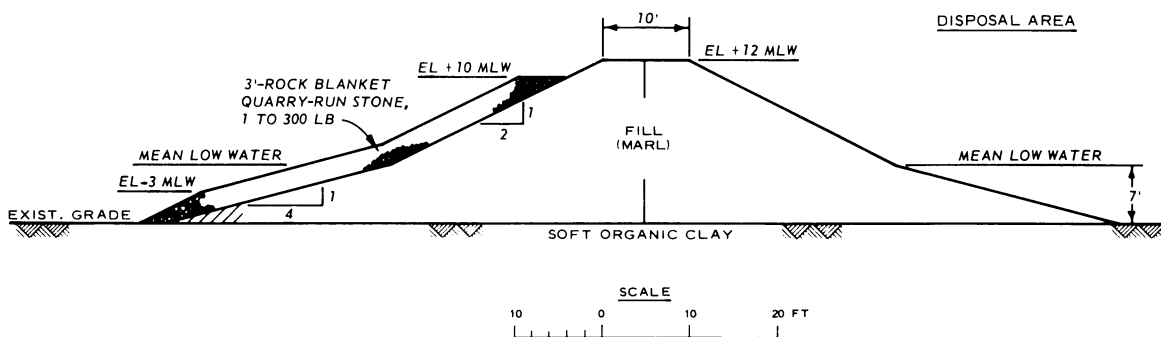
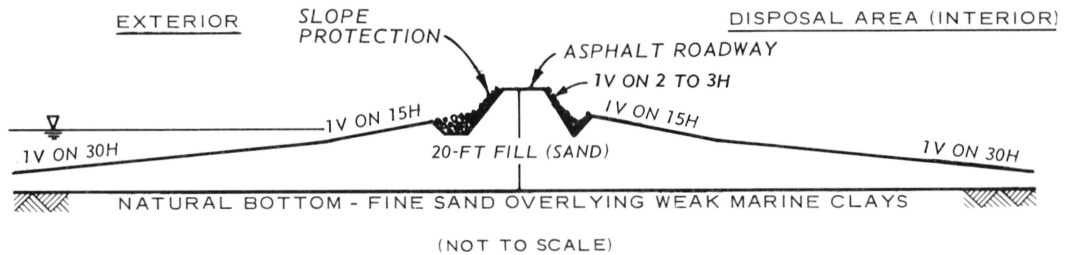

Fig. 25. Typical cross section of retaining dike at Daniel Island (Charleston District)

foundation types: (a) dredged material consisting of clay, silt, and sandy soils of varying organic content, and (b) a cypress swamp of saturated peaty and organic silty and clayey soils. Most of the dike was constructed to a height of 20 to 25 ft with a crown width of 15 ft and side slopes of 1V on 2H. Over the swamp foundation, the dike height was 40 ft. Approximately a 15-ft depth of swamp deposits was removed and slopes were flattened to 1V on 2.5H to attain the 40-ft height over the swamp. Dike material consists primarily of sand and clayey sand.

124. The Norfolk District has been using the Craney Island confined disposal facility (D-3) for the past 15 to 20 yr.^{14,26} The initial dike was constructed in water to a height of 20 ft with 8 ft above the mean low water level. A typical cross section of the Craney Island dike is shown in fig. 26. Below the water surface, side slopes are generally 1V on 30H. Above the water surface, side slopes are 1V on 3 to 5H with a crown width of approximately 25 ft. Slopes were riprapped to provide protection from wave action. The dike is founded on soft marine clays. To obtain an adequate foundation support, hydraulically pumped sand was placed to a base width approaching 600 ft. The Craney Island retaining dike has been raised intermittently by constructing interior dikes and has attained a height of some 20 ft above the surrounding mean low water level.

125. Retaining dikes constructed in the Philadelphia District



NOTE: MAXIMUM WATER DEPTH ALONG THE DIKE ALIGNMENT IS 12 FT.

EXTERIOR SLOPE - RIPRAP, 24 IN. THICK WITH A NOMINAL STONE SIZE OF 1000 LB.
 PROTECTION BEDDING LAYER, 9-IN.-THICK CRUSHED ROCK.
 (SEE b.)

INTERIOR SLOPE - RIPRAP, 12 IN. THICK WITH A NOMINAL STONE SIZE OF 200 LB.
 BEDDING LAYER, 9-IN.-THICK CRUSHED ROCK.

a. Typical cross section (after reference 14)



b. Exterior slope protection

Fig. 26. Craney Island retaining dike
 (Norfolk District)

(B-7) are generally higher than those located in the South Atlantic and Gulf Coast Districts. The Philadelphia District places most of its dredged material in confined disposal facilities. Some containment facilities have been in existence for over 40 yr, and many are located

near populated or industrialized areas. Dike foundations generally consist of dredged material (silt, sand, clay) underlain by soft marsh deposits. Many foundations of existing dikes have improved over the years due to consolidation of subsurface soils. For new dike construction on especially weak foundations, efforts are made to improve dike foundations (see paragraph 172). Initial dike construction is generally carried to heights of 8 to 15 ft, although some dikes have been constructed to initial heights of 20 to 30 ft. Dikes are generally raised in 5- to 8-ft increments; however, in some instances, the Philadelphia District has raised dikes as much as 20 ft in one construction increment. Exterior slope heights of 40 ft or more have been attained through incremental dike raising.

Pacific Coast region

126. Retaining dike construction in the Seattle (A-11) and Sacramento Districts (C-9) has been facilitated by generally good foundations and construction materials. Dredged material and natural foundation deposits used for dike construction in the Sacramento District consist largely of sand. Many retaining dikes are tied into existing flood control levees and are constructed to heights of 8 to 15 ft. Crown widths range from 8 to 12 ft and side slopes are 1V on 1.5 to 2H. In the Seattle District, most retaining dikes have been constructed on sand or silty sand foundations. Dredged material consisting of silt and sand and natural foundation deposits within the containment facilities have been used for dike construction materials. Dikes have been constructed initially to heights of 15 to 20 ft or raised to similar heights in 4- to 5-ft construction increments. Crown widths are limited to 4 ft and side slopes are 1V on 1.5 to 2H. The Seattle District has constructed some dikes on marshes. These dikes were initially constructed of silt or clay to a height of 4 to 5 ft. Exterior slope heights have been raised to 15 to 20 ft in 4- to 5-ft construction increments.

127. Confined disposal facilities in the Portland District generally have been located on marshes or tidelands (A-10). Two island areas near Coos Bay were originally used for unconfined disposal. Dikes in these two areas consist primarily of dredged material (silts, sands,

and shells) and are constructed to heights of 8 to 10 ft with 2- to 3-ft crown widths and 1V on 2H side slopes. At another containment facility near Coos Bay, the initial dikes were constructed directly on the marsh deposits. The initial dikes are composed of silt obtained from within the disposal area. Dredged material consisting primarily of silt has been used for incremental construction to attain exterior slope heights of 10 to 15 ft. The crown widths are about 3 ft and side slopes are 1V on 3 to 5H.

128. Several containment facilities in the Portland District have been provided by the Port of Portland, Port Authority. These facilities are located in marsh terrain, and the dikes are constructed of sand and silt dredged material placed at an average side slope of 1V on 3H. Through incremental construction, exterior slope heights have reached 30 ft with a crown width of 12 to 14 ft and interior slope heights up to 15 ft. During original dike construction, hydraulically placed sand was used to form a wide-base foundation for support on the soft marsh deposits.

Great Lakes region

129. A variety of retaining dikes are in existence or have been proposed for construction in the Chicago, Detroit, and Buffalo Districts. The retaining dikes constructed in the Chicago District range in height from 6 to 15 ft with 1V on 2H side slopes and are composed of sand or a silt, sand, and clay mixture (A-12). The Chicago District also uses a containment facility owned by the Inland Steel Company, which is unique in that the retaining dike is an earth-filled cellular steel sheet pile wall. Each cell is about 40 ft wide and is located in water with an average depth of 25 ft. Similar steel sheet pile structures have been proposed for construction of the Milwaukee Harbor²⁷ (D-7) and Waukegan Harbor²⁸ (D-8) containment facilities. Embankment-type structures are also proposed for portions of the retaining dikes in the Milwaukee and Waukegan Harbors. The proposed dikes are to be constructed of earth and/or rock fill to heights of 25 to 30 ft in water depths of 15 to 20 ft. Typical cross sections of the proposed Milwaukee and Waukegan Harbors retaining dikes are shown in figs. 27 and 28, respectively.

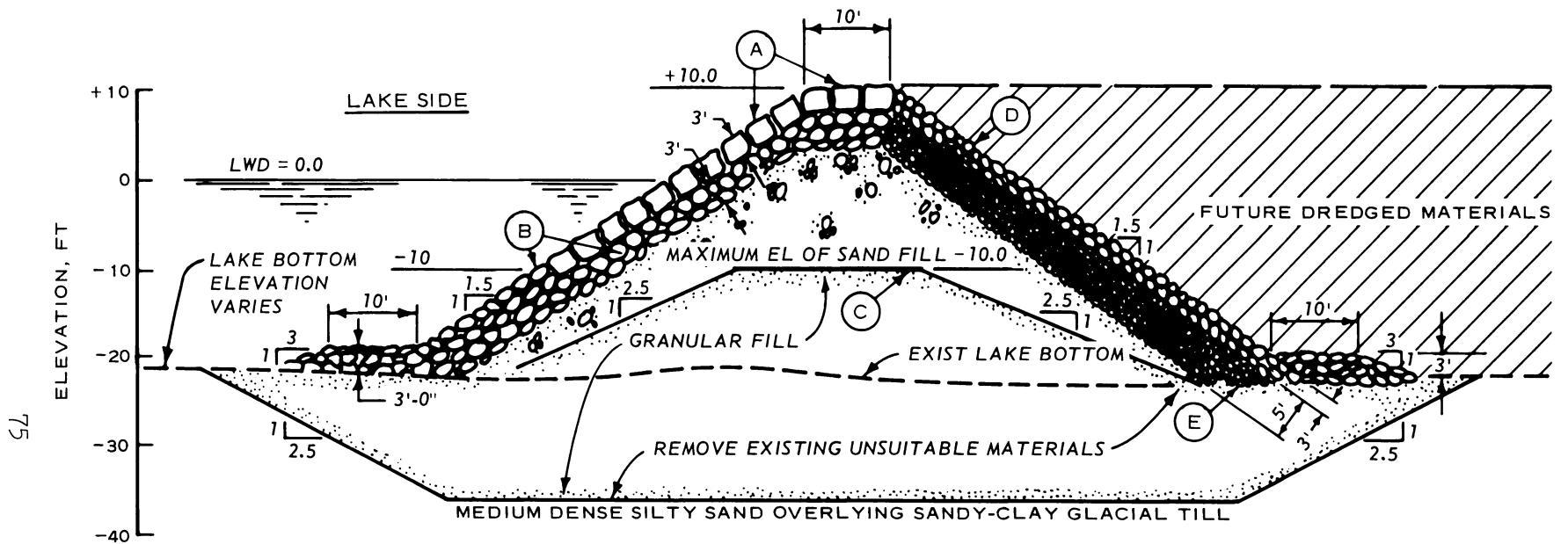

MATERIAL DESCRIPTIONS

- TYPE A - 2000 TO 3000 LB
- TYPE B - 200 TO 1200 LB
- TYPE C - 5 TO 200 LB
- TYPE D - NO. 4 SIEVE TO 150 LB
- TYPE E - NO. 40 SIEVE TO 125 LB

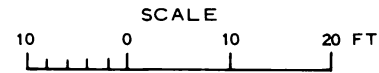
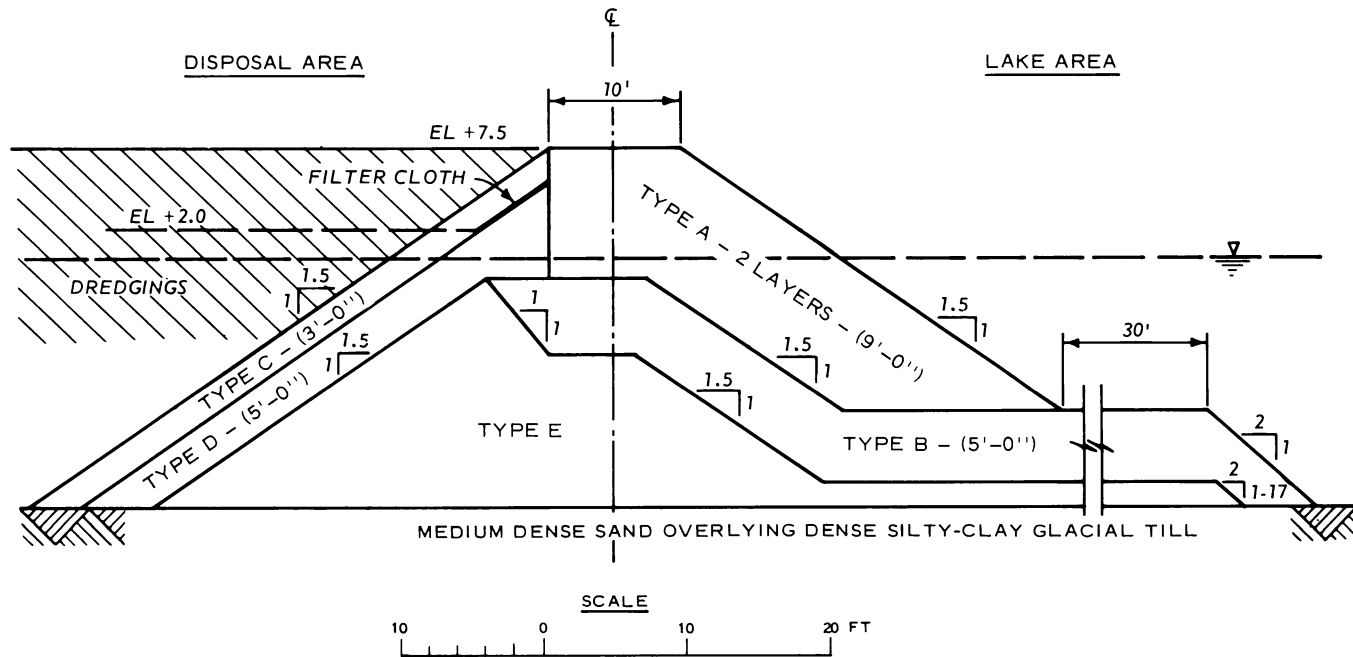

Fig. 27. Typical cross section of east wall of proposed retaining dike at Milwaukee Harbor (Chicago District)



MATERIAL DESCRIPTIONS

<u>TYPE A</u> - 8-TON MAXIMUM; 5-TON MINIMUM	<u>TYPE D</u> - STONE WEIGHT OR SIEVE SIZE	PERCENT BY WEIGHT PASSING
<u>TYPE B</u> - 2000-LB MAXIMUM; 1-LB MINIMUM (200-LB AVERAGE)	125 LB	100
<u>TYPE C</u> - STONE WEIGHT OR SIEVE SIZE	70 LB	80 TO 100
150 LB	5 LB	60 TO 75
70 LB	1 IN.	30 TO 50
5 LB	NO. 4	15 TO 35
1 IN.	NO. 16	10 TO 30
3/8 IN.	NO. 40	10 TO 25
NO. 4	<u>TYPE E</u> - QUARRY-RUN STONE UP TO 125 LB	
	0 TO 5	

Fig. 28. Typical cross section of east wall of proposed retaining dike at Waukegan Harbor (Chicago District)

The Waukegan Harbor section (fig. 28) is undergoing revision and may include a sand-covered filter cloth on the interior dike slope. Slopes of the dikes will be heavily riprapped to provide protection from wave action.

130. The Detroit District has several confined disposal facilities, a number of which are located adjacent to rivers or within rivers as islands. Foundations consist of soft silts and clay. Dikes have been constructed in 6- to 10-ft increments and consist largely of clays, sandy clays, or silty sands. Dike heights range from 15 to 20 ft above the surrounding river level with crown widths of 8 to 10 ft and side slopes of 1V on 2H. Average exterior slopes may actually be as flat as 1V on 3 to 5H since dikes are commonly raised by constructing interior dikes (C-8).

131. Buffalo District generally uses two Cleveland Harbor (D-4) and two Buffalo Harbor (D-5, -6) containment facilities for dredged material disposal. The Cleveland Harbor retaining dikes are constructed of rock fill to a height of 30 ft with a crown width of 10 ft and side slopes of 1V on 1.5H. The height of dike above the surrounding water surface ranges from about 5 to 10 ft. A typical cross section of the Cleveland Harbor retaining dikes is shown in fig. 29. Retaining dikes for the two Buffalo Harbor areas are composed largely of blast furnace slag and are 20 to 25 ft high with a crown width of 10 to 20 ft and 1V on 2H side slopes. Typical cross sections of the Buffalo Harbor retaining dikes are shown in figs. 30 and 31. Exterior slopes of the Cleveland and Buffalo Harbors retaining dikes are heavily riprapped for protection from wave action. A third Buffalo Harbor containment facility has been proposed by the Buffalo District²⁹ (D-9). The retaining dike will be either a 50-ft-high earth- and rock-fill structure (cross section, fig. 32) or an earth-fill steel sheet pile wall. Dike height above the surrounding water surface will be about 20 ft.

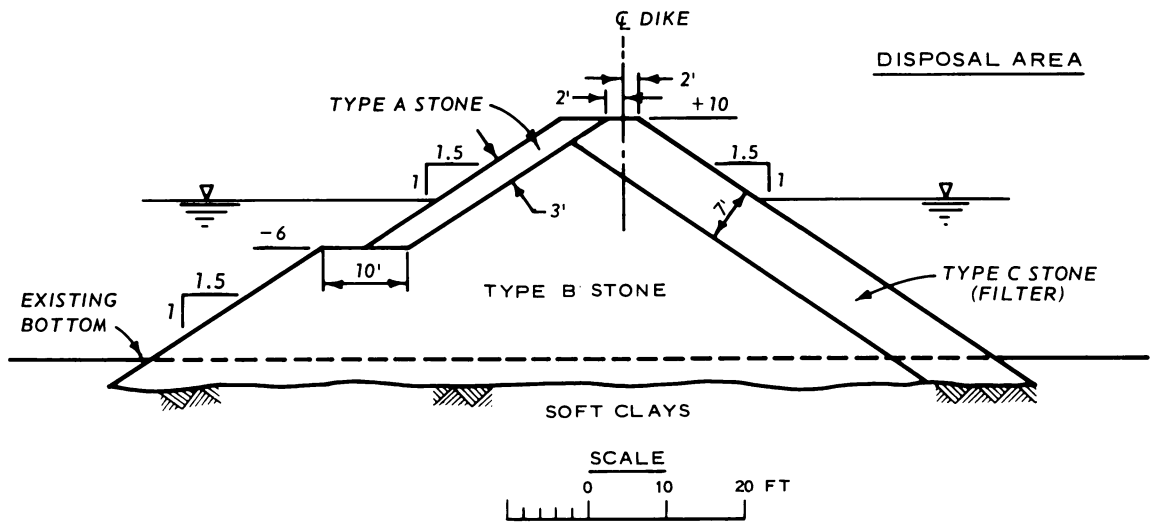

MATERIAL SPECIFICATIONS

TYPE A STONE. THE STONE SHALL BE GRADED FROM THE COARSE TO THE FINE SIZES. THE MAXIMUM SIZE SHALL BE 1400 LB AND THE MEDIAN SIZE (I.E., THE 50 PERCENT SIZE BY WEIGHT) SHALL BE APPROXIMATELY 400 LB. STONES WEIGHING LESS THAN 90 LB EACH MAY COMPRISE UP TO BUT MAY NOT EXCEED 15 PERCENT, BY WEIGHT, OF THE TOTAL MASS OF STONES AND WILL NOT BE USED IN DETERMINING THE MEDIAN SIZE. NEITHER THE BREADTH NOR THE THICKNESS OF ANY STONE SHALL BE LESS THAN ONE-THIRD OF ITS LENGTH.

TYPE B STONE. THE MAXIMUM-SIZE STONE SHALL BE AT LEAST 50 LB. AT LEAST 50 PERCENT, BY WEIGHT, SHALL BE IN PIECES WEIGHING NOT LESS THAN 15 LB EACH, AND NOT MORE THAN 15 PERCENT, BY WEIGHT, SHALL BE IN PIECES WEIGHING LESS THAN 5 LB EACH.

TYPE C STONE. THE STONE SHALL BE REASONABLY WELL GRADED THROUGHOUT AND FALL WITHIN THE FOLLOWING LIMITS:

<u>PERCENT PASSING BY WEIGHT</u>	<u>STONE SIZE</u>
100	125 LB
85 TO 100	70 LB
50 TO 70	5 LB
15 TO 30	NO. 4
10 TO 23	NO. 16
7 TO 22	NO. 40

Fig. 29. Typical cross section of the retaining dikes at the two Cleveland Harbor disposal facilities (Buffalo District)

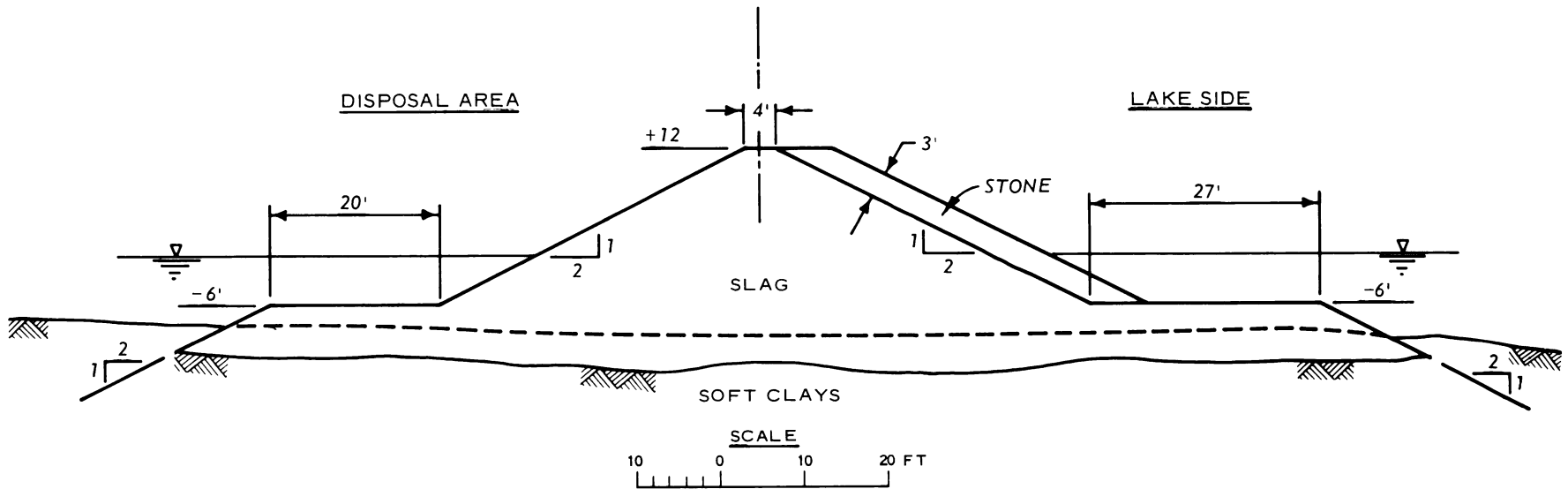

MATERIAL SPECIFICATIONS

SLAG. THE DIKES SHALL BE CONSTRUCTED OF BLAST FURNACE SLAG. THE SLAG SHALL BE PIT RUN (AVAILABLE LOCALLY). THE SLAG IS REASONABLY WELL GRADED WITH PARTICLES FROM 8 TO 1/2 IN. IN DIAMETER.

STONE. THE STONE SHALL BE WELL GRADED FROM A MAXIMUM SIZE WEIGHING APPROXIMATELY 1400 LB TO THE MINIMUM SIZE WEIGHING APPROXIMATELY 25 LB. AT LEAST 50 PERCENT, BY WEIGHT, SHALL BE IN PIECES WEIGHING APPROXIMATELY 400 LB EACH. AN ALLOWANCE OF 15 PERCENT BY WEIGHT FOR INCLUSION OF STONES WEIGHING LESS THAN 25 LB WILL BE PERMITTED.

Fig. 30. Typical cross section of the retaining dike at Buffalo Harbor disposal facility No. 1 (Buffalo District)

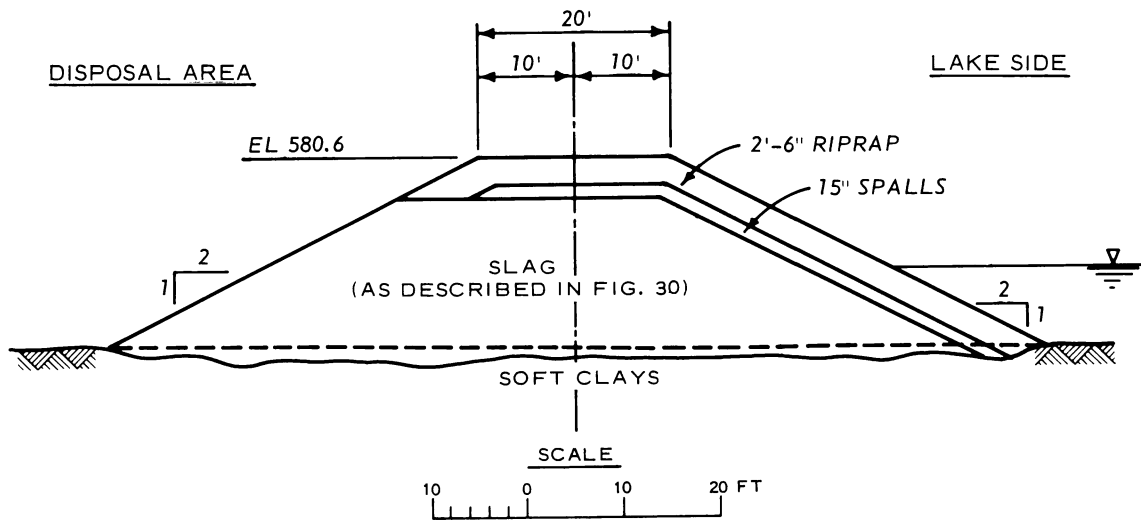

SPECIFICATIONS FOR MATERIALS USED IN SLOPE PROTECTION

STONE FOR THE RIPRAP SHALL BE SOUND, DURABLE, AND FREE FROM CRACKS, SEAMS, AND OVERBURDEN. THE CONTRACTOR'S OPERATIONS SHALL BE CONDUCTED IN A MANNER THAT WILL PRODUCE STONE MEETING THE REQUIREMENTS SPECIFIED AND SHALL INCLUDE SELECTIVE QUARRYING, PROCESSING, HANDLING, AND LOADING AS NECESSARY. THE CONTRACTING OFFICER MAY REQUIRE CHANGES AS NECESSARY TO PRODUCE THE REQUIRED PRODUCT.

RIPRAP SHALL BE REASONABLY WELL GRADED FROM THE LARGER TO THE SMALLER SIZES AND SHALL FALL WITHIN THE FOLLOWING GRADATION LIMITS:

<u>STONE WEIGHT LB PER STONE</u>	<u>PERCENT OF TOTAL WEIGHT LIGHTER THAN LIMIT</u>
1800	100
1500	85 TO 100
600	30 TO 50
100	0 TO 15

NEITHER THE BREADTH NOR THICKNESS OF ANY STONE SHALL BE LESS THAN ONE-THIRD OF THE LENGTH.

SPALLS SHALL BE COMPOSED OF TOUGH, DURABLE CRUSHED STONE OR NATURAL GRAVEL FREE FROM THIN, FLAT AND ELONGATED PARTICLES. THE TOTAL OF DELETERIOUS MATERIAL, ORGANIC MATTER, SHALE, AND SOFT, FRIABLE PARTICLES SHALL NOT EXCEED 5 PERCENT BY WEIGHT.

Fig. 31. Typical cross section of the retaining dike at Buffalo Harbor disposal facility No. 2 (Buffalo District)

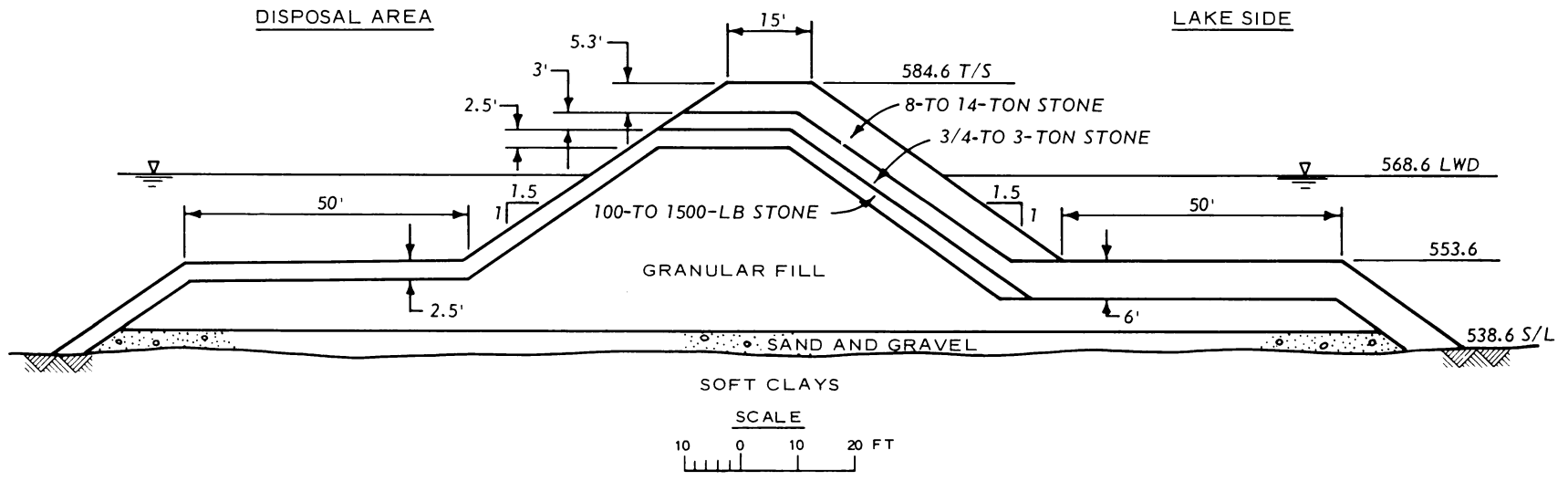

Fig. 32. Typical cross section of the retaining dike for a proposed Buffalo Harbor disposal facility (Buffalo District)

Retaining Dike Design

132. The volume of dredged material requiring confinement has rapidly increased in the last few years, and the consequences of dike failure are potentially critical in many areas. Therefore, some Districts have taken the responsibility for retaining dike design and have designed the dikes using sound engineering principles. Since most retaining dikes have been constructed in unpopulated areas, there has been a general reluctance by CE Districts to conduct extensive field explorations and design analyses. They have felt that the consequences of failure in such areas would be minimal. However, extensive studies have been conducted for a number of retaining dikes in some areas.

CE-designed retaining dikes

133. The extent of CE design efforts is influenced greatly by experience gained through previous dike construction and the consequence of failure. CE design efforts consist primarily of field investigations, laboratory tests, and various design considerations.

134. Field investigations. Investigations at the containment facility sites are usually conducted to determine properties of available borrow materials and foundation soils. A visual inspection of the site and disturbed sample borings within the proposed containment facilities and along the proposed dike alignment are generally the extent of most field investigations. However, some field investigations are limited only to visual inspection of the site. This practice is especially prominent where existing dikes are raised. In these cases, District personnel feel that they have sufficient general knowledge of foundation conditions and the types of dredged material that have been placed in the area. This knowledge combined with a visual inspection of the area and experience with previous dike construction and behavior is considered by the District to be sufficient information to determine the necessary dike dimensions.

135. Disturbed sample borings are included in the field investigations for most retaining dikes designed by the CE. "Disturbed sample borings" refers to borings using methods such as auger, cable tool, and

drive sampling. Split spoon drive sampling is commonly conducted with penetration resistance recorded. Penetration resistances are later correlated to shear strength. Disturbed samples are used for visual soils classification in the field.

136. Undisturbed sample borings and in situ testing of subsurface soils are conducted only when a more accurate determination of foundation shear strength is deemed necessary for special design cases. Undisturbed samples are used primarily for laboratory triaxial shear tests. Other than penetration resistance determinations, the most common field test has been the vane shear test. Undisturbed boring and/or in situ vane shear tests are generally associated only with specially designed containment facilities, such as the Sabine Lake facilities, Galveston District (D-1); Craney Island, Norfolk District (D-3); Military Ocean Terminal facility at Sunny Point, Wilmington District (C-6); Cleveland and Buffalo Harbor containment facilities, Buffalo District (D-4, -5, -6); and the proposed Milwaukee Harbor containment facility, Chicago District (D-7). Except for the Cleveland and Buffalo Harbor facilities, field investigations for the aforementioned areas included undisturbed sample borings but no in situ strength testing. The Buffalo District relied primarily on in situ vane shear tests to estimate foundation design shear strengths for dike design at the two Cleveland and two Buffalo Harbor containment facilities. Philadelphia District obtains undisturbed specimens and conducts in situ vane shear tests at critical locations along the proposed dike alignments. The Detroit District has included undisturbed sample borings and in situ vane shear tests in field investigations for dike designs. The Mobile District has only recently begun designing dikes and has included in situ vane shear tests and undisturbed sample boring in its field investigations.

137. Laboratory tests. Disturbed and undisturbed soils samples are subjected to various tests to determine engineering properties of foundation and borrow soils. The primary purpose for obtaining disturbed samples is to classify the soils based on the Unified Soils Classification System (USCS) and determine in situ moisture contents and plasticity. Most soil samples are visually classified in the field and

in the laboratory. In design of most retaining dikes, only a few representative soil samples are subjected to the Atterberg limits and/or grain-size analysis laboratory tests required for more precise classification. In most cases, shear strengths of embankment material are estimated based on experience or previous tests on similar materials. However, consolidated-undrained triaxial tests (R-tests) were conducted on compacted borrow material to be used for dike construction at Sunny Point. In specimen preparation, compaction effort was chosen to simulate proposed construction procedures. Shear strengths of foundation soils are generally determined from triaxial shear tests of undisturbed soil samples. Normally, the unconsolidated-undrained triaxial test (Q-test) is conducted since most foundation soils are fine-grained cohesive soils and the intended construction period is not of sufficient length to allow consolidation. However, R-tests were conducted on some undisturbed foundation specimens preceding design of the Sunny Point retaining dikes, Wilmington District, and the Craney Island retaining dikes, Norfolk District.

138. Other shear strength tests sometimes conducted on foundation materials are unconfined compression tests, direct shear tests, and miniature vane shear tests (torvane tests). Unconfined compression tests were conducted on undisturbed foundation soils samples from the Sabine Lake and Craney Island retaining dike foundations. Undisturbed foundation soils samples from Craney Island were also tested in direct shear. Philadelphia District has used the torvane shear test device on undisturbed foundation samples, but the results have been highly erratic and thus unreliable for use in retaining dike design.

139. Compaction, permeability, and consolidation tests are only rarely conducted. Compaction tests were conducted on borrow soils (silty and clayey sand) for the retaining dikes at the Military Ocean Terminal, Sunny Point, containment facilities. Permeability tests were also conducted on some of the compacted specimens using clean water and a simulated dredged slurry of 4 parts sea water to 1 part silt.³⁰ Permeability with respect to the simulated dredged slurry was about one-fourth that measured using clear water. Based on permeability test

results, it was decided to discharge dredged material with a high solids content in critical dike zones. It was expected that the clogging effect of the fines would reduce seepage through the dike. Consolidation tests were conducted on undisturbed samples of the weak marine clays underlying the Craney Island retaining dikes.²⁶

140. Other laboratory tests that have been conducted in connection with retaining dike design include riprap quality studies for the Sabine Lake disposal facility and model studies for the Daniel Island disposal facility. Laboratory tests were conducted to check the quality of potential riprap material for exterior slope protection on the Sabine Lake retaining dikes.¹¹ Properties such as unit weight, abrasion resistance, and absorption were measured for various quarry stones available in the Sabine Lake area. Model studies were conducted to measure current effects during and after construction of the Daniel Island retaining dikes.²⁵ The experiments, which were carried out at WES, aided in determining optimum construction scheduling and showed that the completed dike would not adversely affect navigation in the adjacent channels.

141. Design considerations. From the discussion in the preceding section, it can be concluded that field and laboratory investigations are often minimal and yield only a rough idea of foundation and construction material properties. Likely, no special effort is made to improve foundation conditions, and construction materials are normally borrowed from within the containment area although such materials often possess poor engineering properties. The method of construction generally has been established through past diking practices and is not likely to be altered by any particular foundation and construction material properties. Consequently, the selection of dike dimensions is based largely on a review of previous dike construction experience. Dike heights, side slopes, and crown widths are chosen to match those of similarly constructed retaining dikes which have performed satisfactorily. In many cases, a successful and stable retaining dike is obtained; however, where foundation and construction materials are poor or dikes have been constructed to appreciable heights, frequent failures occur and continual maintenance is required.

142. More recently, extensive and detailed retaining dike design studies have been conducted on a fairly regular basis by a number of Districts. Design is generally most comprehensive for containment areas included in any one or all of the following categories:

- a. Facilities proposed for use over a period of years.
- b. Facilities for which a reclamation or development project is scheduled after the area is filled.
- c. Facilities in locations where the consequence of failure is considered severe.

143. Factors commonly considered in design are foundation conditions, construction materials and methods, seepage control, slope protection, and stability. Dike design is generally adapted to the most economical and available construction materials which are compatible with the foundation conditions. Normally, the construction materials are selected from within or adjacent to the containment area, and construction methods are chosen to facilitate use of such materials. However, borrow for several of the in-water confined areas came from local quarries, and in some instances stone for slope protection was shipped from distant quarries. Once the basic construction materials and methods have been determined, the dike cross section is selected based on stability determinations. When necessary, special consideration may be given to seepage control and slope protection. Various CE Districts' general practices and specific examples will be discussed to illustrate the various design considerations and associated analyses.

144. Table 1 summarizes the procedures employed by eight Districts in conducting stability analyses on retaining dikes. When stability analyses are conducted, the Districts commonly use CE Engineer Manual EM 1110-2-1902, "Stability of Earth and Rock-fill Dams,"³¹ as a guide for analyzing stability. As indicated in table 1, analyses are generally limited to areas within one or more of the categories mentioned in paragraph 142. For instance, the Galveston District normally conducts stability analyses only for cases in which dike failure can result in flooding of populated areas. In the Philadelphia District, stability analyses are generally restricted to cases in which the dikes are

exceptionally high and/or located on very poor foundation materials.

145. In most cases, dikes are analyzed by the circular arc and/or wedge methods, with the circular arc analysis being the more common. Normally, only the end of construction case is analyzed, although in some instances, such as those in which land-based dikes are constructed of relatively pervious materials, the steady seepage case is also analyzed. The required factor of safety is generally 1.2. At Daniel Island in the Charleston District, the dikes had a factor of safety approaching 1. This relatively low factor of safety was acceptable to the District since other dikes in the area were similarly constructed and have performed satisfactorily.²⁵ The relatively high factor of safety of 1.9 computed for the Craney Island dikes is not the required factor but the minimum factor of safety for the dike as constructed. The dike was constructed by the hydraulic fill method, which results in relatively flat slopes. In this case, the slopes were dictated by the construction method rather than the stability analysis.

146. Shear strengths for embankment materials are almost always estimated rather than determined in the laboratory. These estimates are usually based on experience developed by the District through the years. In the Galveston District, many of the estimates are based on shear strengths determined from tests on similar materials used in the design of flood protection levees. Estimates of the shear strength of the sand embankment at Craney Island were based on correlations of shear strength with density and grain size contained in reference 32. At one facility, the shear strength of the primarily dragline-constructed clay embankment was estimated based on tests of clay fill placed by hydraulic dredge. Since shear strength is dependent on both the material and the method of placement, it would appear that many estimates of embankment shear strength are subject to considerable error.

147. In stability analyses, foundation shear strengths are often more critical than embankment shear strengths. Consequently, the Districts place more emphasis on establishing foundation strengths. Most design strengths are based on unconsolidated, undrained conditions (Q-test or vane shear test). It was found that most foundations for

retaining dikes consist of fine-grained, slow-draining materials which do not have time to consolidate significantly during construction. In the more permeable soils, such as those found in a portion of the foundation at the Military Ocean Terminal, there is time for consolidation and consequently strengths are based on the R-test. R-test strengths were determined on clays at Craney Island to evaluate long-term strength gains. Designs for dikes founded on soft, fine-grained material in the Philadelphia District are usually based on in situ vane shear data. Past experience in this District indicates that shear strengths measured by the Q-test on undisturbed samples are lower than strengths measured by the in situ vane shear test and the apparent actual shear strength of the foundation materials.

148. Permeability and consolidation tests are rarely conducted. If the permeabilities of foundation and/or embankment materials are required for a seepage analysis, they are usually estimated based on the soil type and various correlations with grain size parameters. Consolidation of embankment or foundation materials is usually not accounted for in design. At Craney Island, settlement analyses indicated that the dike would settle approximately 4 to 5 ft within 15 yr following construction, but this settlement was not considered in the final design. When excessive consolidation occurs, dikes are raised or repaired as required.

149. Most designs require dike slopes to be seeded immediately following construction to protect against erosion during rainfall. However, more substantial slope protection is often required where dikes are subjected to wave or current action. Exterior slope protection is common on the retaining dikes of confined disposal facilities constructed in water. Dikes experiencing only intermittent exterior wave action often do not receive slope protection. These would include dikes susceptible to waves produced by passing ships or river currents during flood flows. Most of the in-water retaining dikes also require protection on their interior slopes. Many large ponded, land-based containment facilities are also protected in this manner to prevent erosion of dike slopes by wind-produced interior wave action. Small containment

areas are especially susceptible to interior slope erosion caused by high discharge rates during disposal operations.

150. Riprap underlain by a blanket of bedding materials is the most common type of slope protection. The bedding materials are needed to protect the embankment from erosion due to water penetrating the riprap. Riprap size and thickness and bedding are generally designed according to procedures presented in the CE Engineer Manual EM 1110-2-2300, "Earth and Rock-fill Dams, General Design and Construction."³³ However, the exterior slope protection at Sabine Lake¹¹ was designed based on methods contained in a U. S. Army Coastal Engineering Research Center publication entitled "Shore Protection Planning and Design."³⁴ Details of slope protection for the various retaining dikes will be described herein in a section entitled "Retaining Dike Construction."

151. Retaining dikes subjected to interior wave action or heavy discharge flow only during intermittent dredging operations are in some cases lined with polyethylene sheeting. Several Districts reported that polyethylene sheeting works well as protection for interior slopes from wave or current action. In addition, the sheeting has been useful in preventing materials from being blown from the dike's surface, which could be a nuisance in populated areas.

152. Special seepage control measures are generally not incorporated into retaining dike design. The only deterrent to seepage that has been used in several instances is the lining of interior slopes with polyethylene sheeting. Since the sheeting is impermeable, it can reduce the quantity of seepage through the dike. Several Districts have reported that polyethylene liners are fairly successful in controlling seepage but are not totally reliable. The Mobile District lined the interior slopes of a 12-ft-high sand dike with 6-mil polyethylene sheeting placed in vertical strips (C-10). The polyethylene tore easily during placement and was later damaged by rodents. Consequently, the polyethylene did little to prevent seepage; however, it did perform satisfactorily in preventing interior slope erosion. The ability of a polyethylene liner to prevent seepage may also be affected by its method

of installation. At Mobile, the vertical strips were overlapped 2 to 3 ft, but the joints were not sealed. When used on retaining dikes in the Galveston District, the joints are sealed with pressure sensitive tape; these liners have performed successfully.

153. A unique design feature was employed in the Vicksburg District's industrial fill retaining dikes (C-1). The 245-acre industrial fill and its associated retaining dikes are shown on the plan in fig. 5. The industrial fill project had a drainage system within the retaining dikes to prevent the future accumulation of water within the sand fill.³⁵ Drains were installed at 500-ft intervals along the interior dike toe. Each drain consisted of 50-ft sections of 6-in.-diam perforated, corrugated metal pipe surrounded by a sand and gravel filter. Collected water is transmitted to the dike's exterior within a 6-in.-diam pipe, which extends through the dike. A typical cross section of the dike and drain installation is shown in fig. 33. An installed drain is shown in fig. 34. The drainage system has performed satisfactorily. It would appear that the installation of internal drainage systems designed for the type of material being deposited may be desirable to aid in future development of any confined disposal facility.

Contractor-designed dikes

154. Many retaining dikes are constructed immediately prior to the dredging operation. The design and construction of these dikes are often the responsibility of the dredge contractor. Design efforts and investigations conducted by the dredge contractor or his subcontractor are for the most part unknown. It is likely that little funds or effort are expended on site exploration or dike design and construction since the dredge contractor's business is dredging at the lowest possible cost. The CE generally supplies the dredge contractor with results of certain field and laboratory studies and stipulates various requirements which may affect dike design. Such items are discussed in the following paragraphs.

155. Field investigations. The CE normally provides the dredge contractor with an estimated quantity and description of the materials to be dredged. Quantities are usually estimated from channel surveys,

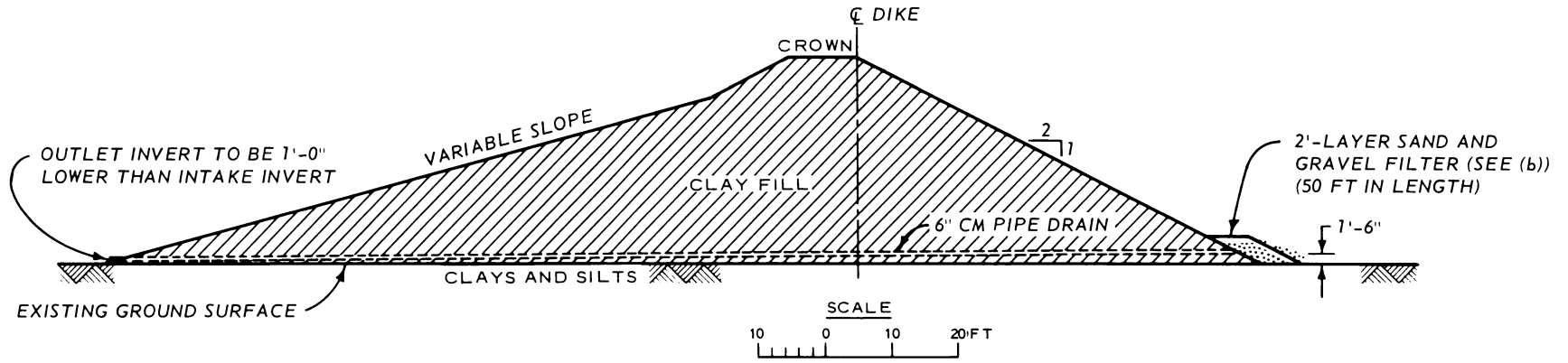

a. CROSS SECTION OF RETAINING DIKE AND INTERIOR TOE DRAIN

T6

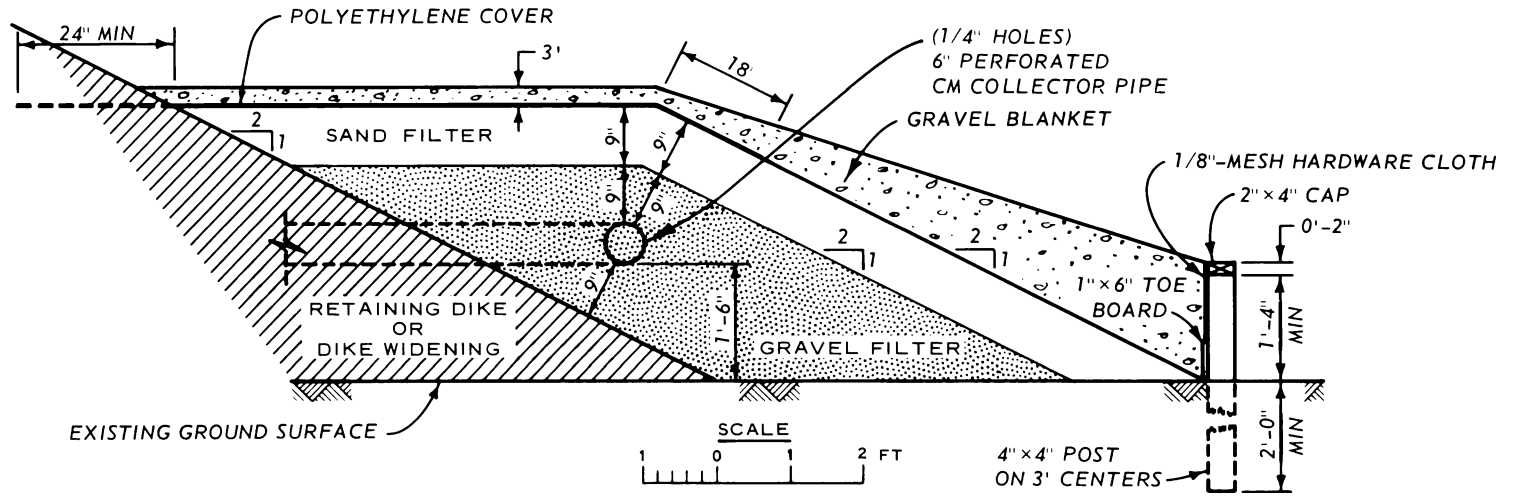

b. DETAILED CROSS SECTION OF INTERIOR TOE DRAIN

Fig. 33. Retaining dike for industrial fill project (Vicksburg District)

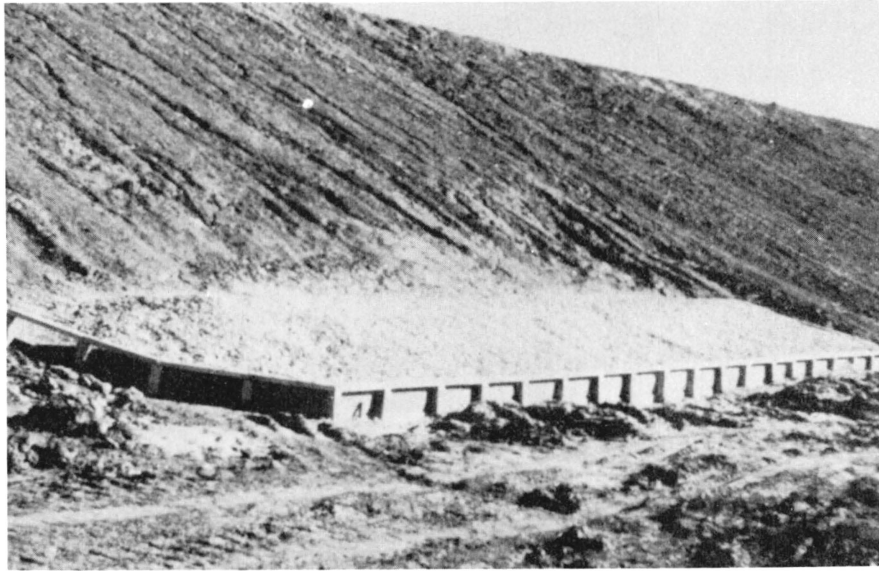

Fig. 34. Interior toe drain for industrial fill retaining dike (Vicksburg District)

while material descriptions are often based on results of disturbed sample borings within the area to be dredged. In a number of cases, however, the types of materials to be dredged are determined from a review of past dredging records. In a few instances, contractors have been supplied with logs of disturbed sample borings made along or within the dike alignment. Split spoon drive sampling is generally conducted in the dike foundation, and in rare instances in the material to be dredged. Split spoon penetration resistances are recorded and indicated on the boring logs. In some cases, consistencies of the subsurface soils are estimated from the split spoon penetration resistances and listed on the boring logs. All disturbed samples are visually classified in the field.

156. Laboratory tests. Normally, no laboratory tests are conducted by the contractor to aid in the design of dikes. Results of tests conducted by the CE are made available to the contractor or are a part of the specifications. Information provided the contractor generally includes the USCS classification and moisture contents of foundation and borrow materials determined from disturbed samples. Samples are normally only visually classified although in some instances

the samples are more precisely classified. Occasionally, the grain-size distributions of materials to be dredged are provided. Rarely are laboratory tests conducted to establish the shear strength of foundation materials.

157. Design requirements. When dike design and construction are the responsibility of the dredge contractor, the basic design requirement in the contract specifications is usually stated in the following manner: "All dikes...needed for confining the dredged material within the spoil areas...shall be provided...by the contractor."³⁶ In some cases, the proposed dike alignment is not specified. When the alignment is not specified, the contractor can choose whether to dike all or only a portion of the land designated for disposal. This practice has been criticized by many CE personnel since often the areas diked are too small, resulting in overtopping and subsequent failures.

158. In some instances, the specifications are more detailed. In one contract specification, two methods were indicated by which the dimensions of the dikes and diked area could be estimated. They were as follows:

Dimensions of the dikes and diked area shall be such that the diked area will contain either one hundred and fifty percent of the estimated contract quantity or one hundred percent of the estimated contract quantity plus a two-foot freeboard to the dike top.³⁷

159. A few Districts require the contractor to submit plans and computations showing the proposed dike alignment, dimensions, and proposed borrow areas. This appears to be good practice; however, it was indicated that in many cases such plans and computations are incomplete, making examination by CE personnel difficult. In such cases, the intended purposes have not been fulfilled.

Retaining Dike Construction

160. Construction materials, methods, and costs vary considerably among the various CE Districts. Although most confined disposal facilities are located on land, there are a number of existing in-water

containment facilities, and others are proposed for future construction. Dike construction on land often differs significantly in terms of materials, techniques, and costs from construction in water. Land-based and in-water construction will be discussed separately in the following sections. Land-based construction includes the retaining dikes founded on upland and marshland areas. In-water construction includes those dikes located in water having a significant mean low water depth along the major portion of the dike alignment.

Land-based construction

161. Construction materials. Composition of individual dikes generally depends on locally available borrow materials. Borrow materials for dike construction are normally obtained from within the disposal area and adjacent to the dike alignment, and as a rule the engineering properties of such soils are less than desirable. The specific types of borrow soils used in constructing land-based retaining dikes in various regions of the United States were discussed in the section entitled "Description of Retaining Dikes."

162. Contract specifications generally provide little guidance concerning construction material quality. Typically, specifications indicate only that construction materials can or will be obtained from within the containment area. Statements in contract specifications are similar to the following: "Material from the disposal areas may be used to construct the dikes."³⁷ Such statements usually are not accompanied by any further description or requirement of borrow material quality. District personnel suggest that acceptable borrow materials need not be described in contract specifications since it is generally known what types of materials exist adjacent to the dike alignment. Contracting officers often make verbal suggestions in the field concerning material quality and construction methods, and such suggestions are usually heeded.

163. To avoid certain undesirable materials in dike construction, a few Districts do provide some contract specifications concerning borrow material quality. The Charleston District usually specifies that: "The dike material shall not contain an excess of grass, roots, or other

organic material and its suitability shall be determined by the contracting officer as the work progresses."³⁸ The Charleston District provided more detailed specifications concerning borrow materials for construction of the Morris Island area retaining dikes (C-4). Contract specifications regarding construction materials were as follows:

Probing and borings made by the Government in the area to be inclosed by the dike indicate that a sufficient quantity of material suitable for use in the dike is available from the borrow area shown on the drawings, and that this area has the least amount of unsuitable material as overburden....In the event any portion of any borrow area yields material which, in his opinion, is unsuitable for use in the dike, the contracting officer may direct that the depth of excavation be changed or that the excavating equipment be moved to other portions of the borrow area that will yield suitable material....The dike shall be constructed of material such as that found from elevation -14 ft to elevation -41 ft on the log of boring 7. Overburden to be removed and disposed of is material such as that shown above elevation -14 ft on the log of boring 7.³⁹

164. The Philadelphia and Galveston Districts often provide contract specifications relating to construction materials. The Philadelphia District commonly specifies that: "Material shall be free of all stumps, logs, timber, roots over 2 in. in diameter, and all vegetal-laden material such as peat and sod."⁴⁰ The Philadelphia District also designates the borrow areas on the contract drawings; also, the contract specifications require that borrow areas be cleared and grubbed.

165. Galveston District often designates borrow areas on the contract drawings. Typical material specifications are as follows:

- a. The embankment shall be constructed of approved materials obtained from approved borrow areas. Satisfactory embankment materials shall be classified...as CL, CH, or SC.⁴¹
- b. Embankment materials shall consist of clay soils obtained from within the spoil area and shall be free from vegetation, stones, debris, and other objectionable material.⁴²

166. The Wilmington District does not usually provide contract specifications concerning dike construction material quality. However,

borrow material location and quality were specified in detail for construction of the retaining dike at the Military Ocean Terminal containment facility (C-6). A portion of the specifications referring to the borrow areas and material quality was as follows:

Borrow areas: Borrow shall be obtained from within the perimeter of the dike....Borrow Area B: Strip-ping of existing dredged material as described...to depths as directed over areas of occurrence, and stripping only to the extent necessary to provide suitable material nearly free of vegetative matter in remaining areas shall be performed....Materials for embankment fill shall be secured from the borrow areas indicated on the drawings and may be obtained from other required excavation....Materials containing brush, roots, sod, or other perishable materials will not be considered suitable....Suitable material for the dike embankment shall consist of sand (SP, SP-SM, SM), clayey sand (SC), and mixtures thereof. Soil comprised of marine limestone fragments classified as above or as GM or GC is included as a suitable material.⁴³

167. Foundation preparation. For many retaining dikes there is no preparation or treatment of the dike foundation. However, in some cases, there is some degree of clearing and grubbing and possibly strip-ping of the dike foundation.

168. The Philadelphia District required clearing and grubbing of foundations for several retaining dikes located along the Chesapeake and Delaware Canal. Specifications were as follows:

Clearing shall consist of the removal and satisfactory disposal of all trees, brush, trash, and debris. Trees and brush shall be cut off to a height not exceeding 12 in. above the existing ground surface.⁴⁰

Grubbing shall consist of the removal and satisfactory disposal of stumps and roots of trees and other vegetation greater than 2 in. in diameter.⁴⁰

Charleston District specifications generally include a requirement such as: "The area beneath the dikes as shown on the drawings shall be cleared of trees, stumps, roots, brush, and other vegetation. Trees and other vegetation shall be cut off at or slightly below the original ground surface."⁴⁴

169. Although foundations may be cleared and grubbed, stripping is generally limited to those dikes which will be constructed of compacted fills. The purpose of stripping is to remove low-growing vegetation and organic and highly compressible or otherwise undesirable soils. Stripping normally involves only the removal of foundation soils to a depth of 6 in. to 1 ft. Material suitable as topsoil may later be redistributed on the dike for seeding purposes. Following the stripping operations, cavities or depressions in the foundation surface are broken down and flattened, or they may be backfilled. The entire foundation is then thoroughly loosened and compacted. If the compacted surface appears too smooth and hard to provide a good bond between the fill and foundation, it may again be loosened before placement of the embankment fill.

170. At the Military Ocean Terminal disposal facility (C-6), removal of as much as 10 to 15 ft of dredged material and swamp deposits was required to improve foundation conditions along some portions of the dike alignment. The dredged material to be removed consisted of mixed organic and inorganic clay, silt, and sandy soils having a high water content. The swamp deposits consisted of saturated peaty and organic silty and clayey material. All excavation was backfilled with the type of material to be placed in the embankment and compacted to the same density as that required of embankment fill.⁴³ The major portion of the foundation was then compacted to the density required of the embankment fill.

171. Removal of large amounts of soft deposits is not always practical, especially where the depths of weak deposits are very great. In such cases, the foundation conditions can be improved through displacement of the soft deposits. The fill is placed on the soft material and allowed to sink and ultimately displace the soft foundation deposits. The most efficient technique is by end-dumping the fill and using a bulldozer to push the fill into the soft foundation. Fill is hauled in and dozed into the foundation until a firm base is established upon which the retaining dike construction can continue. It is considered that a firm base is attained when the fill ceases to sink appreciably and will

support the weight of the bulldozer or hauling equipment. Although a stable base section is established, settlement of the fill will occur during construction of the upper dike section. This is caused by continued displacement and consolidation of the foundation material under the weight of additional fill.

172. Displacement by end-dumping has been used only on a few occasions and for the purpose of initially constructing a dike to a substantial height on soft dredged material or marsh deposits. The Mobile District used the technique in constructing retaining dikes to a height of 10 to 12 ft on soft marsh deposits (C-10). Sand obtained from a previous new-work dredging project was used in dike construction. Truck-hauled and -dumped sand fill was pushed into the foundation by bulldozer. A 16-ft thickness of old dredged material and marsh deposits was displaced (fig. 35). During construction, a wave of displaced foundation

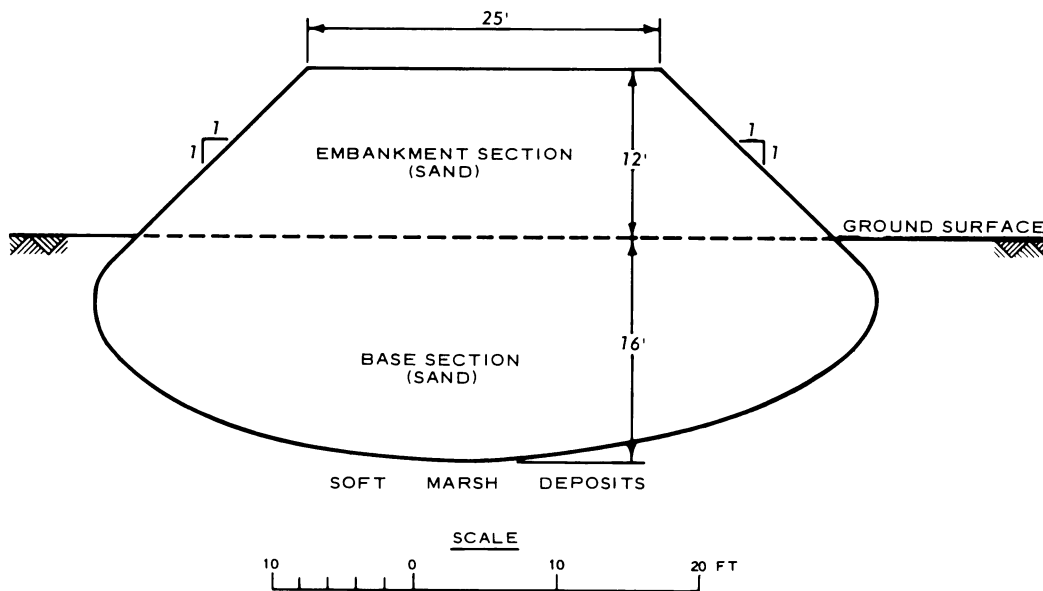

Fig. 35. Typical cross section of retaining dike constructed by end-dumping fill to displace soft foundation materials

material (mud wave) formed at the head and sides of the advancing fill. The shape of the base section below original ground indicated in fig. 35 was roughly estimated from borings made after dike construction was completed. A retaining dike in the Philadelphia District was constructed

to a height of 30 ft by first displacing a 6- to 10-ft thickness of soft organic silty clay and peat deposits (A-8). The base section was constructed by end-dumping silty sand obtained from a nearby borrow area.

173. Embankment construction. Fill placement with draglines is the most common method used for retaining dike construction. Dragline fill is not normally compacted, but in some cases bulldozers or crawler tractors are used to shape and slightly compact the materials. Materials placed by dragline are usually taken from within the containment area and placed as shown in fig. 36. A borrow ditch formed by such construction is shown in fig. 37. Draglines used for building dikes near water

Fig. 36. Dragline construction of a retaining dike at Craney Island (Norfolk District)

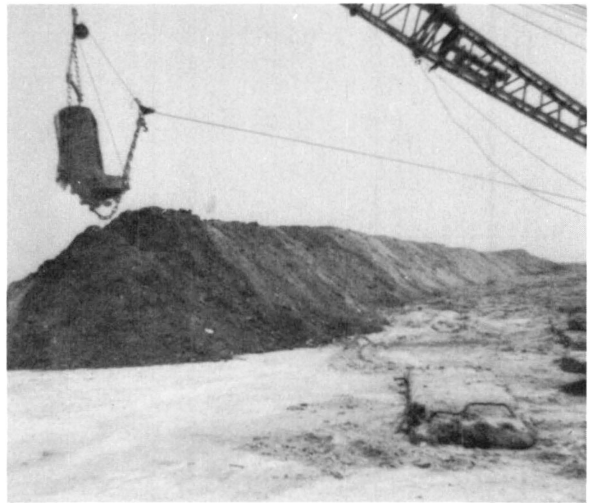

Fig. 37. Borrow ditch (at left of dike) for dragline-constructed dike (Portland District)

are often mounted on barges. On soft deposits, draglines are placed on timber mats, or marsh cranes are used. (Marsh cranes are draglines mounted on pontoons.) A crawler track around each pontoon acts as a paddle in water and provides a deep tread on soft ground. Marsh cranes are capable of operating on very soft marsh deposits with a great degree of efficiency.

174. Construction on soft foundations by dragline is often difficult, and dike heights are limited to only a few feet. Dike material undergoes considerable settlement due to displacement of the underlying deposits. If excessive sinking of the fill occurs, construction is discontinued, and the fill is allowed to stabilize before continuing construction. This technique is known as stage construction and is generally preferred over flattening slopes or constructing berms. Stage construction may be applied only as a remedial measure at unstable sections, or it may be the intended method of construction for the entire dike. The Philadelphia District sometimes specifies two-stage construction.⁴⁰ A period of 90 days is allowed for settlement of the first stage.

175. Contract specifications relating to dragline construction often require that a minimum berm width of 15 to 40 ft be left between the dike's interior toe and the borrow ditch. This is done primarily to protect against dike failure by sliding into the borrow ditch. One District indicated that the interior berm width is also needed to prevent future dike increments from being founded on the fine-grained, soft wet deposits that collect in the borrow ditch.

176. Borrow materials are commonly placed at their natural water content and not compacted. In some instances, the embankment materials are "semicompacted." Semicompaction normally infers that there is some type of compaction of the material but that the water content at which the material is placed is not specified or rigidly controlled. The Philadelphia District commonly requires that "embankment material be placed in approximately equal layers not exceeding 12 in. in loose thickness before compaction."⁴⁰ The material is then compacted by routing of hauling and spreading equipment over the entire surface of each layer. The Galveston District has similar requirements for semicompacted

embankments concerning lift thickness, but the type of compaction equipment and the compaction effort are also specified in detail. Although the moisture content is not specified, most Districts have the requirement that the material is unacceptable if it is too wet. The contracting officer decides if the borrow material is too wet, and the decision is normally based on visual observations. The Philadelphia District considers the material too wet if it will not support compaction equipment. In such cases, the material is normally placed on the embankment fill and allowed to dry before compaction.

177. Stockpiling wet borrow materials to allow drainage would probably significantly improve its engineering properties, but this is rarely done. However, the Philadelphia District has significantly improved the quality of wet organic silts by stockpiling them in steep-sided mounds 6 months prior to construction.

178. The most stringent specifications encountered for compaction of embankment materials were those for the construction of the Military Ocean Terminal retaining dikes. The compaction equipment, procedures, and field testing are described in detail in references 43 and 45. Although the placement water content per se was not specified, it was required that the water content be that necessary to obtain a density of not less than 90 percent maximum density. Maximum density was determined by the modified compaction test described in EM 1110-2-1906.⁴⁶ When material was too wet to obtain the required compaction, it was spread on the embankment and dried by disking, plowing, or harrowing until an acceptable moisture content was obtained. The contractor was required to maintain a field soils testing laboratory and perform moisture content, density, compaction, mechanical analysis, Atterberg limits, and specific gravity tests to assure material and construction quality. Such laboratory requirements are certainly the exception rather than the rule, since for most dike construction moisture contents are not even determined.

179. Hydraulically pumped materials have been used to construct land-based retaining dikes when it is desirable to construct a wide dike section. Hydraulic construction in marshes is generally performed

to distribute the load across a "stiff mat" which overlies the soft marsh deposits. The stiff mat is a layer of earth reinforced with a network of roots. A base width of as much as 200 ft may be established by hydraulic placement. The material is then reworked by bulldozer or dragline to construct the central section. At Morris Island, the dike was constructed by hydraulic fill followed with shaping of the central section by bulldozer (C-4). A typical cross section of the Morris Island dike is shown in fig. 38. Borrow materials consisted of loose, fine

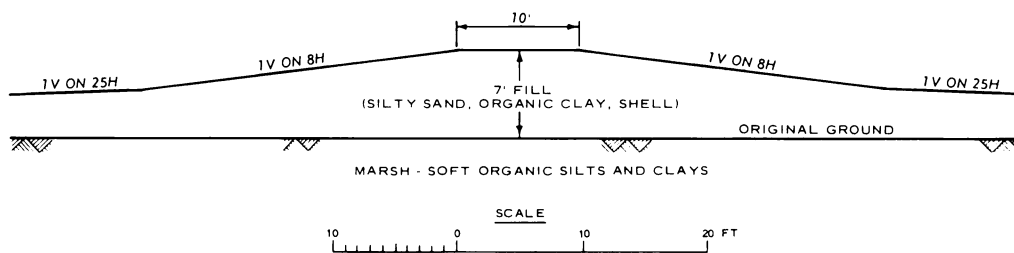

Fig. 38. Typical cross section of retaining dike at Morris Island (Charleston District)

silty sand with high organic clay and shell contents. The dike was founded on marsh deposits consisting of soft organic silt and clay.

180. Hydraulically placed sand has been used in the Savannah District for original dike construction to heights of 4 to 6 ft in marsh areas. Side slopes of 1V on 15 to 30H and base widths of 150 to 200 ft are common. Similar methods have also been used in the Portland District area for original dike construction on soft marsh deposits.

In-water construction

181. Construction materials. A variety of materials have been used in constructing retaining dikes for in-water confined disposal facilities. The best locally available materials are generally used. Where alternative materials are available, the choice is often based on economic considerations. Stone protection is required on in-water retaining dikes to prevent slope deterioration caused by wave and current action. Stone protection varies considerably since normal and storm condition wave heights will vary with dike locations. In the following paragraphs, only general descriptions are given of the construction

materials. More detailed material descriptions are given in the referenced figures and dike descriptions.

182. With two exceptions, all the proposed or existing major in-water retaining dikes are constructed of granular materials. The exceptions are the Sabine Lake dikes, which are constructed of clays, and the Daniel Island dikes constructed of marl. The Craney Island dike, shown in fig. 26, was constructed of locally available sands, while the retaining dikes for the two Cleveland Harbor containment facilities (fig. 29) were constructed of rock fill. The dikes for the two Buffalo Harbor containment facilities (figs. 30 and 31) were constructed of locally available blast furnace slag. Various combinations of sands and rock-fill materials are planned for dike construction at the proposed Milwaukee (fig. 27), Waukegan (fig. 28), and Buffalo (fig. 32) Harbor containment facilities.

183. The Sabine Lake retaining dikes (fig. 24) were constructed of stiff clays obtained from specified borrow areas within the containment area. The Daniel Island retaining dikes (fig. 25) were constructed primarily of marl dredged from a nearby river. The marl is generally classified as a calcareous clay. The marl discharges in the form of lumps or clay balls ranging from the size of marbles to basketballs with enough fines and sand to fill the voids.²⁵ This wide variation in particle sizes produces a dense matrix and a sound embankment.

184. Slope protection for all the dikes is stone. The size, layer thickness, and number of layers are determined by the design procedures discussed previously in "Design Considerations." Use of the stone protection shown in the previously referenced figures is dependent on such factors as the embankment slope, wave height, and availability of material. The interior slope protection used for the Cleveland Harbor dikes also serves as a filter to improve the quality of water emerging from the exterior slopes. As discussed in Part III, there has been no difficulty with filters clogging.

185. Construction techniques and equipment. Methods used in constructing retaining dikes for the in-water containment facilities are:

(a) hydraulic pumping, (b) dragline or clamshell, and (c) dumping methods.

186. Hydraulic pumping of materials is an economical method of establishing a large volume dike section which may be necessary for stability on very soft foundations. Generally, the wide hydraulic fill section is constructed to an initial height above the surrounding water. The upper portion of the dike is then shaped with draglines or other equipment using the coarse-grained materials which are generally provided from initial hydraulic construction. The Craney Island retaining dike shown in fig. 26 was constructed of hydraulic sand fill placed below the water surface and topped with a clamshell-constructed central section reaching a height of 8 ft above the water surface. Trenches from the clamshell excavation were left in the hydraulic fill on either side of the central section. These trenches were later filled with stone to serve as the toe of the riprap protection shown in fig. 26. On several occasions, the hydraulic fill generated mud waves ahead of construction caused by displacement of the underlying weak clays.¹⁴ These waves had to be removed before construction could continue. The mud wave problem was solved by distributing the fill more evenly with a floating swing discharge line.

187. The Daniel Island retaining dike shown in fig. 25 was constructed of hydraulic fill largely composed of dredged marl. The hydraulic fill was placed at an average side slope of 1V on 8H to a height of 5 ft above the water surface. The hydraulic fill placement also created mud waves in the displaced soft foundation materials. A barge-mounted dragline reworked the material to the cross section shown in fig. 25.

188. The Sabine Lake retaining dikes were constructed largely by dragline casting of materials obtained from borrow areas adjacent to the dike alignment as shown in fig. 24. Materials placed by dragline were shaped and compacted by bulldozer. A short length of the Sabine dikes was constructed by hydraulic pumping since no suitable borrow materials were located adjacent to that portion of the dike alignment.

Draglines and bulldozers were used for shaping and compacting the hydraulic fill section.

189. Rock fill for the two Cleveland Harbor retaining dikes (fig. 29) was dumped from barges by a conveyor-type unloader. Slopes were then shaped by clamshell. Slag fill for the Buffalo Harbor facilities retaining dikes (figs. 30 and 31) was end-dumped from hauling trucks. This procedure requires that construction begin adjacent to the shore and progress outward as a haul road is established. Slopes of the slag-fill dikes were shaped by clamshell.

190. Slope protection on the in-water dikes is normally placed either by clamshell or orange peel. The orange peel method is most suitable for placement of large individual stones. There was one instance where riprap was placed by end-dumping. Stone protection at the first Buffalo Harbor dike shown in fig. 30 was initially placed by end-dumping from truck; however, much segregation occurred as the material rolled down the slopes and this method was considered undesirable. End-dumping operations were halted and a clamshell attached to a barge-mounted crane was used to continue placement of the stone protection. The clamshell or orange peel is normally operated from a barge-mounted crane although at the second Buffalo Harbor area dike shown in fig. 31 the crane was located on top of the dike.

Construction costs

191. Construction cost data were obtained for several land-based and in-water containment facility retaining dikes (tables 2 and 3). Sites are listed in ascending order of cost per cubic yard of disposal capacity provided by the dike. Actual costs of existing sites were obtained where possible, but, where actual costs were unavailable, bid cost estimates or CE estimates are listed. Costs of proposed structures are based on District estimates. Costs may include construction of sluices and other drainage facilities in addition to actual dike construction (see "Remarks" in tables 2 and 3). Some of the data are for dike raisings. In such cases, the computed capacity is the volume obtained only from that construction increment.

192. Factors contributing to cost. Many factors influence

retaining dike construction costs. The time required for construction can greatly affect costs since labor and equipment costs are commonly high. Disposal site location can influence the type of construction equipment needed: for example, barge-mounted draglines or marsh cranes may be required. Crew support facilities such as sleeping and dining facilities may be required in remote or isolated locations. Site investigations and construction materials, techniques, and equipment can greatly affect construction costs. For example, the use of selective fill, compaction of materials, or extensive foundation preparation can produce construction costs higher than those of retaining dikes for which such techniques or materials are not required. Large quantities of stone for slope protection can also increase costs considerably. For example, purchase of limestone riprap hauled from a remote source for use on the Sabine Lake retaining dikes (D-1) was responsible for 40 percent of the total cost of dike construction.

193. Comparison of construction costs. The cost per cubic yard of disposal capacity was used as the basis for comparison of dike construction costs. Land-based dikes ranged in cost from \$0.01 to \$0.11 per cubic yard of capacity. There was no significant difference in cost between original dike construction and dike raising. The in-water dikes were generally much more expensive than the land-based dikes and ranged in cost from \$0.08 to \$6.30 per cubic yard of capacity. In terms of capacity attained, the most economical in-water dikes were those of the large Craney Island (D-3) and Sabine Lake (D-1) disposal facilities. These areas have capacities significantly greater than those of the other in-water diked containment facilities. No attempt was made to correlate cost with dike composition or size because of the many cost-contributing factors. There may also exist various cost incongruities since many of the costs were based on estimated costs prior to construction.

Retaining Dike Performance

194. The basic purpose of confining dredged material is to

prevent its spread and possible harm to the environment. In many instances, the intent of confinement has not been attained as retaining dikes often require continual maintenance and repair.

Consequences of failure

195. Confined disposal facilities are often located near valuable lands and waters including residential and industrialized areas. Where containment areas are adjacent to agricultural, industrialized, or populated areas, the consequence of failure is immediate and obvious. However, in other areas the consequence of failure is expressed in terms of environmental impact and can only be determined by subsequent investigations. For many containment facilities in unpopulated locations, retaining dike foundations and construction materials are generally very poor, and there is a tendency for less effort and expense to be applied to dike design and construction. Consequently, dike failures have been more frequent in such locations.

196. Most retaining dike failures have resulted in the flow of dredged material onto tidal flats and marshes or into nearby rivers and streams. The washed out sluice section shown in fig. 39a resulted in flooding of the adjacent tidal flats shown in fig. 39b (A-10). The failures shown in fig. 40 allowed over 1,000,000 cu yd of slurry to escape into an adjacent river (A-7). The mudline in the background of fig. 40a is indicative of the height of slurry immediately prior to failure. Dredging contractors are generally required to redredge material lost through dike failure; however, redredging is not always possible. The dredged material spreads in thin layers on land or is dispersed in adjacent waters and carried away by the prevailing currents.

197. Not all failures have been confined to unpopulated or otherwise open areas. Damages to warehouses, a railroad embankment, a sewage treatment plant, pastureland, and even flooding of a housing subdivision have been reported. The 150-ft-long break shown in fig. 41a caused flooding of the sewage treatment plant facilities shown in fig. 41b (A-6).

198. In addition to property and structural damage, there is often the expense of redredging and repair. At McDuffie Island,¹⁷ over



a. Washout at sluice structure



b. Debris on tidal flats downstream of failed sluice structure

Fig. 39. Retaining dike failure (Portland District)



a. A 50-ft-wide break in the 25-ft-high dike section



b. Sluice structure which settled 9 ft and moved horizontally outward a distance of 6 ft

Fig. 40. Retaining dike failures allowing 1,000,000 cu yd of dredged material to flow into an adjacent river (Philadelphia District)



a. A 150-ft-wide break in the 20-ft-high dike section



b. Flooded sewage treatment plant

Fig. 41. Retaining dike failure resulting in flooding of a nearby sewage treatment plant (Philadelphia District)

600,000 cu yd of material was lost through dike failures, and over 300,000 cu yd of material was dredged specifically for dike repair (A-2). To stabilize the dikes, the pond depth was lowered considerably, and this resulted in another 500,000 cu yd of material being lost over the weir. In effect, 57 percent of the material dredged escaped from the McDuffie Island confined disposal area. The contractor was responsible for redredging 600,000 cu yd of material at his own expense. In general, contractors are not reimbursed by the CE for any necessary redredging as a result of dike failures. However, since contractors are aware of diking difficulties, their bid estimates are likely to be inflated to allow for redredging and dike maintenance expenses if necessary.

Causes of failure

199. Retaining dike failures are generally the result of a combination of factors. Foundation conditions, construction materials, and, in some cases, construction methods and disposal practices have contributed to dike instability and failure.

200. Foundation conditions. Retaining dikes are often founded on soft or marshy deposits and are, therefore, especially susceptible to foundation shear failures. The most common failures are by sinking or, where layering and stratification are present, by spreading.^{31,47} A sinking failure is common in uniform soft clay deposits and is characterized by a rotational movement along a shear surface through the embankment and foundation as shown in fig. 42a. A spreading failure generally takes one of two forms and is common where the foundation consists of stratified deposits of soft clay. The first type of spreading failure is similar to failure by sinking and is common where the clay strata are homogeneous. Sliding occurs along a weak horizontal layer within the clay stratum as shown in fig. 42b. The second type of spreading failure is shown in fig. 42c and is common where the clay strata contain extensive lenses of coarse silt and sand. The embankment slopes move as a block outward from the center creating a troughlike depression in the central portion of the dike as shown in fig. 42c. The wedge stability analysis method simulates this type of failure. A detailed explanation of sinking- and spreading-type failures is given in

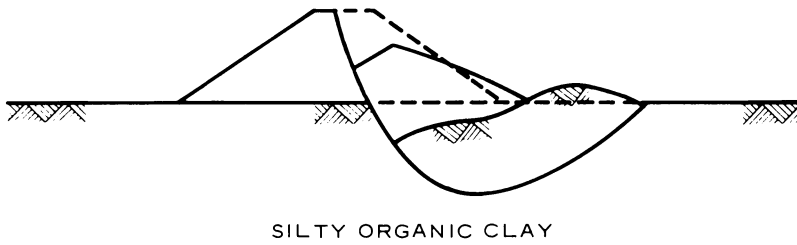

SILTY ORGANIC CLAY

a. SINKING FAILURE

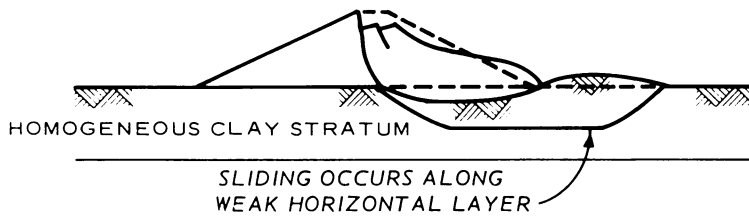

HOMOGENEOUS CLAY STRATUM

SLIDING OCCURS ALONG
WEAK HORIZONTAL LAYER

b. SPREADING FAILURE, HOMOGENEOUS CLAY STRATUM

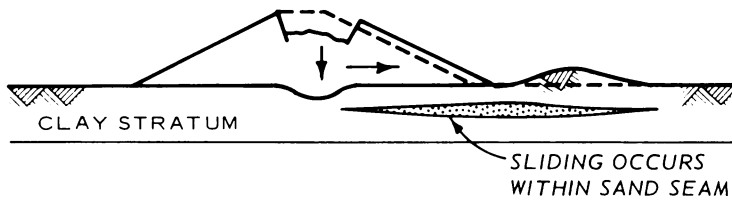

CLAY STRATUM

SLIDING OCCURS
WITHIN SAND SEAM

c. SPREADING FAILURE, CLAY STRATUM
WITH SAND SEAMS

Fig. 42. Types of foundation shear failures
(after reference 47)

reference 47. The retaining dike failures shown in fig. 40 appeared to have been by sinking. It was reported that the sluice structure shown in fig. 40b settled 9 ft and moved horizontally outward a distance of 6 ft. The dike was 6 to 10 ft high and constructed of uncompacted silty sand placed by dragline. The foundation consisted of dredged material underlain by soft tidal marsh deposits (A-7). Elsewhere, a 10- to 15-ft-high dike constructed of sandy silt and founded on dredged material and marsh deposits appeared to have failed by spreading (B-3). In this instance, a 300-ft-length of the dike failed prior to dredging operations. It was noted that the riverbank, which was located about 60 ft from the dike's exterior toe, displaced laterally a distance of approximately 25 ft.

201. Another type of foundation failure unique to some marsh areas is "mat breakthrough." The mat is a stiff surface layer reinforced with a network of roots which overlies much softer deposits. If the stiff mat is overloaded and breaks, the retaining dike will sink rapidly into the underlying soft deposits.

202. Construction methods and materials. Embankment shear strengths are often low due to the uncompacted placement of wet undesirable materials. Such embankments are susceptible to shear failures, which are often induced by seepage and weak foundations. Low foundation and embankment shear strengths combined with the effects of seepage are responsible for most retaining dike failures. At McDuffie Island, dikes constructed of wet silts placed by dragline in an uncompacted state experienced numerous failures and needed continual repair.¹⁷ The McDuffie Island retaining dike failures probably included both embankment and foundation shear failures (A-2). Low embankment shear strength was also the cause of failure of a 4- to 5-ft-high dike constructed of wet organic clay placed in an uncompacted state (A-11). The low strength of the embankment was exemplified by the fact that a CE inspector reported that he sank to a depth of about 1 ft into the dike while walking at many locations along the dike alignment.

203. Poor construction techniques and materials have also led to seepage-induced failures. A 5- to 6-ft-high dike constructed of

hydraulically placed sand failed due to internal erosion (piping) caused by excessive seepage at the embankment and foundation contact. This is generally observed in cases in which there is little or no foundation preparation and the dike is constructed directly on existing vegetation.

204. Many failures involved portions of old dikes which had been incorporated into new dike construction. The increase in exterior dike heights, which occurs as a result of intermittent dike raising in the manner shown in fig. 23a, tends to decrease the stability of exterior dike slopes if not properly designed. During dike raisings, it may be desirable to flatten exterior slopes or, if possible, construct interior dikes at some distance inward from the interior toe of the existing dike, as shown in fig. 23b. Inspection of filling operations between dike raisings should be implemented to prevent the collection of debris in the foundation material of subsequent dikes. Failures might occur as a result of piping along buried debris.

205. Seepage effects. The effects of seepage through the retaining dike or its foundation have been directly responsible for or have contributed to many dike failures. Seepage can cause failure either by piping or by sliding. Piping is the internal erosion of material from the embankment or foundation, which undermines the retaining dike causing its collapse. District personnel commented that piping was sometimes initiated by seepage through animal burrows within the dikes. Embankment and foundation sliding failures can occur if pore water pressures become excessive and cause a substantial reduction in shear strength.

206. Seepage likely caused failure of a retaining dike which resulted in flooding of a nearby residential area (C-2). Seeps or springs were observed along the exterior slope of the dike just prior to its failure. The exterior 1V on 3H slope was approximately 15 to 20 ft high. Dike materials consisted primarily of clays obtained from within the containment area and compacted during placement. However, the section of the dike that failed was composed largely of silts and fine sands, which are susceptible to failure by piping.

207. High pore water pressures due to seepage through the dike

were considered to have caused the failure shown in fig. 41a. It appeared to be a shear failure of the embankment and not of the foundation. The dike was constructed of uncompacted silt and clay. The dikes in the facility had an interior height of 8 ft and an exterior height of 12 ft with side slopes of 1V on 1.5H (A-6).

208. Piping was directly responsible for the failure of the cross dike shown in fig. 43a (A-8). Failure of the cross dike allowed a large volume of dredged material to escape into an adjacent lower area of the disposal facility. The sudden surge of dredged slurry overtopped and washed out a section of the lower area retaining dike shown in fig. 43b. The failed dike shown in fig. 43a was about 30 ft high and was composed of silty sand which was compacted during placement by selective routing of hauling equipment. Before constructing the embankment, a firm dike base or foundation was established through displacement of marsh deposits (silty clay and peat) by end-dumping of a silty sand fill hauled from a nearby borrow area. Failure was thought to be caused by seepage and subsequent piping through vertical transverse cracks in the dike base. This conclusion was reached after observing such cracks during reconstruction of the failed section. The transverse cracks were apparently created by differential settlement of the base section. In dike reconstruction, the cracks were excavated and replaced with compacted silty sand.

209. Many retaining dike failures involve or are located near sluice structures since pond depths are generally greatest there and seepage control measures are not normally provided at the structures. Note the close proximity of the sluice structure to the failed dike section in fig. 40a. This structure was also involved in the failure shown in fig. 40b (A-7). Another washed out sluice section is shown in fig. 39a; however, in this case, failure was initiated by collapse of the sluice (A-10). Inspection of the remains of that sluice and others nearby revealed that much of the component wood was rotted. These particular sluices were of the flume type shown in fig. 16. Flume-type sluices are susceptible to erosion along the dike-sluice interface.

210. Erosional effects. Retaining dike failures can also be



a. A 60-ft-wide break in the 30-ft-high cross dike



b. A 50-ft-wide break in the 21-ft-high dike surrounding the adjacent lower area

Fig. 43. Retaining dike failures in a partitioned disposal facility (Philadelphia District)

initiated by wave or current action causing erosion of interior or exterior slopes. Another common problem is the high rate of discharge into relatively small disposal areas. This often leads to erosion of interior slopes, slides, and subsequent overtopping.

211. Deterioration of interior slopes has occurred in large ponded or in-water containment facilities where winds can produce considerable wave action within the area. A few months after construction of the Sabine Lake retaining dikes, wave action eroded the unprotected interior slope and along some locations reduced the crown width by half (D-1).

212. Protection is more often provided for exterior slopes, but damage to both interior and exterior slopes is common during periods of high water or storms. The retaining dike at the first Buffalo Harbor containment facility suffered loss and displacement of riprap and interior slope damage as shown in fig. 44. Damage was caused by waves overtopping the dike (D-5). Containment facilities constructed in low areas have also suffered erosion damage of exterior dike slopes which are adjacent to rivers and channels.



Fig. 44. Storm damage--displacement and loss of stone protection on retaining dike, Buffalo Harbor facility No. 1 (Buffalo District)

Remedial and preventive measures

213. Remedial and preventive measures have been employed to reduce the number and extent of dike failures. Such measures are primarily dike inspection, control of disposal operations, and dike maintenance and repair. Their nature and application are discussed in the following paragraphs.

214. Dike inspection. Adequate inspection of retaining dike construction and inspection of dikes immediately prior to and during filling operations can be very effective in preventing failures. During construction, retaining dikes receive various degrees of inspection by contractors and CE personnel. CE inspection during dike construction is normally more comprehensive in areas where the consequence of failure is considered critical. Limited CE inspection may be applied to construction of dikes which are designed and constructed as part of the dredging contract. However, it is generally known what construction methods and materials are being used. CE-designed dikes constructed under the dredging contract receive at least a minimum CE inspection, which consists of a comparison of the dimensions of the completed dike with those required by the contract specifications. Again, construction methods and materials are generally known.

215. Dike failures tend to occur most frequently during the filling operations, which is also the time when the consequence of failure is most critical. To avoid total washout of the dike, remedial steps must be taken at the first sign of weakness or movement. Consequently, the dredge contractor is normally required to inspect retaining dikes during filling operations. Dike inspection clauses are often included in the dredge contract specifications. Some specifications are more explicit than others as illustrated by the following examples:

- a. The contractor shall inspect for compliance with contract requirements, and record inspection of all operations, including but not limited to....Spoil disposal dikes (adequacy, stability, surveillance for breaks, maintenance)....⁴⁸
- b. To insure that the dikes are performing satisfactorily,

the contractor shall make a minimum of three daily inspections of the dikes during disposal operations (one inspection each 8-hr shift).⁴⁹

Contractors' inspection reports are generally submitted on a daily basis to the CE contracting officer. Many Districts commented that CE inspection of retaining dikes during dredging operations is not conducted on a regular basis due to a lack of available personnel. Dike inspection by experienced CE engineers or technicians would appear desirable, since a CE inspector would be less hesitant than the contractor to point out problem areas and to initiate immediate action for remedial measures.

216. Until recently, dike inspection during dredging operations has consisted primarily of visual observations of surface features. Seepage effects appear to be the main cause of dike instability and failure. A more precise indication of potentially harmful seepage conditions can be obtained from observation wells and piezometers. During the first filling operations at the Sunny Point containment facility (C-6), springs were observed immediately beyond the dike's exterior toe. Observation wells were drilled through the retaining dike to obtain further information concerning the seepage conditions. The Philadelphia District installed piezometers to monitor pore water pressures within the retaining dike foundation during disposal operations at one of its containment facilities. The retaining dike has an exterior slope height of 40 ft and was constructed over deep, soft tidal marsh deposits. The area will be used more frequently in the future because of filling of an adjacent disposal area being used on a rotational basis. Piezometers have been provided to assess the safety during the future, more rapid rates of filling and height increase. The time intervals between periods of use will be adjusted if necessary, depending on the pore water pressure data obtained.

217. It is expected that retaining dike inspection will become more detailed as the consequence of failure becomes more critical. Inspection will increase in both visual observation and instrumentation.

218. Control of disposal operations. Detailed specifications relating to disposal operations are needed to insure dike stability.

Contract specifications generally require that disposal operations cease in the event of dike failure and that the contractor is responsible for dike repair and redredging without reimbursement. Such specifications emphasize the importance of dike stability, but do little to prevent failure. More stringent specifications, used by some Districts, require minimum freeboard. Where specified, the minimum freeboard has been 2 ft. For example, one such specification stated:

A freeboard of 2 ft or more, measured vertically, between the retained materials and water and the top of the adjacent confining embankments, shall be maintained at all times. If the required freeboard is not met, the contractor shall stop pumping into the disposal area until corrective means have been taken satisfactory to the contracting officer.⁵⁰

219. Discharge operations should be controlled to whatever extent feasible. Exact discharge locations and the number of sluices and lengths of weirs have been specified as discussed previously in Part III. One such specification relating directly to dike stability was designed to prevent erosion of the dike's interior slopes. The specification stated:

In placing material on the disposal areas the discharge end of the pipeline shall be kept a minimum of 200 ft inside and away from the dikes during pumping operations to minimize high velocity currents impinging on and causing erosion of the dikes.⁴⁹

Interior slope erosion can also be reduced by lining the inside slopes of the dike with polyethylene sheeting before commencing disposal operations. Six-mil polyethylene sheeting, which has been used for this purpose, costs about \$0.01 per square foot. However, the use of polyethylene sheeting is not generally specified in the contract. Its use is left to the discretion of the dredging contractor. Polyethylene sheeting also aids in reducing seepage through the dike as discussed in paragraph 152.

220. Foresight in dredging operations can aid future dike raising projects. In many Districts, the contractor is encouraged to deposit potentially good dike construction materials near the dike alignment.

This material is then used for incremental dike construction.

221. Dike maintenance and repair. Under current CE contracting procedures, the dredging contractor is generally responsible for dike maintenance and repair during the life of the dredging contract. This applies to all existing dikes as well as those dikes which may have been raised, repaired, or constructed under the dredging contract. The following specifications are typical of those relating to dike maintenance and repair:

- a. The contractor shall furnish necessary waste weirs and maintain existing dikes to preclude the return of excavated materials into Mobile River, Chickasaw Creek, Polecat Bay, or other channels or bodies of water.⁵¹

(These particular retaining dikes were constructed under a separate dike construction contract.)

- b. The contractor shall construct and maintain spoil retaining embankments, waste weirs, and drainage facilities....He shall also be responsible for the stability of all embankments and structures constructed and/or modified by him for use under the contract.⁵⁰

(In this case, the retaining dikes were constructed to detailed CE specifications under the same dredging contract.)

- c. The contractor shall be responsible for maintaining the integrity of the dikes, and for any corrective measures and their costs for any unapproved spillage of material from the dike enclosure.³⁷

(In this contract, retaining dike design and construction were the responsibility of the dredging contractor.) The type of equipment to be kept at the site for use in dike maintenance was specified in the same contract as follows:

Suitable equipment such as a dozer tractor of a size comparable to a D-6...shall be furnished by the contractor to maintain the retaining dikes....The contractor shall have the dozer tractor at the job site whenever dredging is taking place.³⁷

222. It is generally not specified in a dredging contract that maintenance be conducted as prescribed by the CE contracting officer. However, many Districts indicated that dredge contractors normally seek CE advice concerning maintenance operations. Maintenance work during dredging operations generally involves the placement of additional

material or sand bags on settled or sloughed portions of retaining dikes. Polyethylene sheeting has sometimes been used in dike maintenance. At the Blakely Island containment area, seepage through the 10-ft-high sand dikes caused extensive sloughing along a 50-ft length of the exterior dike slope. The dike was repaired using sand bags (C-10).

223. If freeboard becomes deficient along a short length of dike, sand bags may be placed by hand on top of the dike. More often, however, dikes are topped with additional material placed by dragline. In certain cases, this may only aggravate failure by further steepening the slope and overloading the foundation. At McDuffie Island (A-2), attempts were made to raise portions of the retaining dikes by dragline placement of material against a vertical plywood wall.¹⁷ The method proved unsuccessful as dike breaks were numerous. Indiscriminate placement of additional materials on dikes at locations where settlements or slides occur is undesirable and could result in major failures. A more appropriate solution would be to halt disposal operations or at least lower the pond depth to allow time to diagnose the cause of instability. Only then can appropriate remedial action be recommended. However, there is a general reluctance to halt disposal operations anytime before a dike break occurs.

224. Dike failures during disposal operations often require total reconstruction of the failed section. Reconstruction may be conducted immediately following failure at the expense of the dredge contractor. However, in some cases, reconstruction may be conducted through a CE-let dike construction contract or a subsequent dredging contract.

225. Wider dike sections and/or better construction techniques are generally employed in the reconstructed dike sections. In one case, a dike with an exterior height of 10 to 15 ft failed at two locations along its length parallel to and about 60 ft from an adjacent river (B-3). The dike had been constructed through intermittent dike raising by incorporating the old dike into each incremental construction. The latest increment was constructed by dragline placement of silt and sand obtained from within the disposal area. A 200-ft section of the dike failed while the containment area was fully ponded. The CE

reconstructed the failed section with leased equipment and hired operators.⁵² The new dike section was constructed using methods and materials similar to those used for the original dike. However, the new dike center line was shifted toward the interior of the disposal area and berms were used. A 200-ft-long section of the new dike was constructed parallel to and at a distance of 130 ft from the original dike center line. The new dike was constructed to a height of 9 ft with a 10-ft crown width. Berms 6 ft wide and 3 to 5 ft thick were constructed at the base of both the interior and exterior slopes. The dredge contractor had reconstructed a section at the same containment facility in a similar manner immediately following an earlier dike failure in which sliding of the dike and adjacent riverbank had occurred.

226. Dike reconstruction following the failure shown in fig. 41a was conducted according to CE specifications. The failed dike had been constructed through intermittent dike raising by incorporating the original dike into new dike construction. The latest increment was constructed by dragline placement of silt and clay obtained from within the containment area (A-6). The exterior dike height at the time of failure was 20 ft. The dike was raised a height of 10 to 12 ft with an 8-ft crown width and 1V on 1.5H side slopes (B-4). Similar construction materials were used, but they were placed in 1-ft layers and compacted by routing of hauling equipment. The center line of the new dike was located inward from the original.

227. Retaining dikes of intermittently used containment areas often require repairs prior to disposal operations. Repairs are necessitated by storm damage, erosion, settlement, and minor sloughing. As with dike raising, repairs are often made immediately prior to dredging operations and may be a part of the dredging contract. A few Districts reported that CE-owned equipment is sometimes used in dike repair. In some cases, equipment is leased and operators are hired or lump sum contracts are let for dike repair. At the Craney Island disposal site, consolidation of foundation soils has caused a portion of the dike to settle over 7 ft since its construction in 1954. The asphalt roadway on top of the dike (fig. 26) has been repaired on several occasions. Within

a few months after construction of the Sabine Lake containment facility retaining dikes, wave action eroded the unprotected interior slope (see cross section, fig. 24a). Erosion reduced the crown width by as much as half at some locations. New-work dredged material was pumped along damaged sections to produce a crown width of 29 to 30 ft and a flat interior slope to dissipate wave energy. This has proved successful in reducing interior slope erosion. Retaining dikes at the first Buffalo Harbor containment facility (fig. 30) suffered considerable damage due to high waves during storms. Displacement and loss of riprap and core materials occurred as shown in fig. 44. During the repair, additional core materials were added, and riprap protection was extended across the top and down the inside slopes of the dike.

PART V: CONCLUSIONS AND RECOMMENDATIONS

Acquisition of Disposal Sites

228. Acquisition and retention of disposal sites are the primary dredging-related concerns of CE Districts. Environmental restraints and increasing land values severely limit the availability of disposal easements.

229. The congressional act authorizing a project must be consulted to determine responsibility and authority for supplying dredged material disposal easements and facilities. Recently, local interests commonly have been required to supply easements and containment facilities, whereas on older projects the CE was sometimes authorized to supply the necessary lands and facilities.

230. Purchase and maintenance by the Federal Government of dredged material disposal areas suitable for long-range planning are being considered by at least one CE District. This has been brought about by the recent increase in confined disposal and the accelerating depletion of available disposal sites. Another consideration is the granting of economic assistance by the Federal Government and increased cooperation with local interests in supplying disposal easements and containment facilities.

231. Many Districts have been faced with the loss of easements for disposal areas due largely to owners planting crops or building structures in the areas. Some Districts have used the following methods for reducing the loss of easement:

- a. Problem areas are patrolled at appropriate time intervals to watch for building or planting activities.
- b. Clipping services are hired to obtain listings of building permits filed for pertinent areas.

232. Marshland disposal is necessary for many CE Districts. Research will hopefully preclude the indiscriminate banning of disposal of dredged material on marshes and permit environmentally and operationally compatible use to be made of these areas.

Long-Range Planning

233. Several CE Districts are considering or have instituted long-range planning programs for dredged material disposal. The programs indicate that future dredging operations will necessitate consolidation of numerous small disposal areas into fewer, larger sites; development of new dredging and disposal techniques; and transportation of dredged material to more remotely located disposal areas.

234. Dredged material disposal areas are being reclaimed as sites for recreational facilities, for industrial complexes, and for farming purposes. Use of the dredged material itself as industrial raw material and fill, for example, is recommended where applicable.

235. Subsequent disposal operations may require long-distance piping or hauling, construction of containment facilities in deeper water, or periodic emptying of disposal areas for beneficial uses of dredged material. Study of a highway project using hydraulic fill indicates that long-distance piping can be achieved using a continuously operating dredge in series with long pipelines and booster stations.

Containment Facility Design and Operation

236. Most disposal areas are inefficient because of inadequate planning and design, insufficient knowledge of dredged material characteristics, and lack of long-term, large-acreage disposal easements.

237. Sufficient capacity for containment of dredged material sometimes is not provided. CE Districts use various design factors in estimating the required containment facility volume. The determination of effective design factors is a critical research need.

238. Little is known of sluice characteristics and how they affect effluent quality. Many CE dredging and diking contracts leave sluice placement and configuration to the discretion of the contractor. Experimentation with various sluice configurations by modeling (mathematical and physical) and in actual disposal operations should be implemented where possible to bring about systematic improvement of sluice

design as it affects effluent quality.

239. Channelization of dredged slurry from discharge to sluice, the effects of wind on dike stability and disposal area operations, and the mounding within the disposal area of coarse fractions of dredged materials seem to be the primary operational problems confronting users of dredged material containment facilities.

240. It may be possible to redistribute dredged material from mounded areas to lower areas with land-grading equipment after a year or so of settlement and drainage of the material or during dredging operations using all-terrain vehicles. More efficient use would thus be made of the containment facility.

241. Efforts at improving disposal area efficiency are generally mechanical; for example, the widespread use of cross dikes and spur dikes and splash plates. More sophisticated and quantitative means, including application of settleability rates of dredged sediment, flocculation, and estimated ponding time and weir crest length, are being investigated by some Districts but are not used consistently throughout the CE.

242. Disposal area effluent standards and monitoring procedures are not consistent nationwide. Consequently, CE Districts have adopted their own or State water quality standards. Several parameters are used to measure water quality.

243. Disposal area effluent standards and monitoring procedures need clarification. Recommendations to this end should consider existing capabilities of CE Districts in achieving set standards and the existing local background level of water to which effluent is returned.

Diking Methods

244. Retaining dikes are primarily earth embankments constructed on lowland areas or nearshore islands. Several in-water containment areas have been constructed, and, in certain cases, rock fill or slag has been used for dike construction. Some alternatives to earth- and rock-fill embankments for in-water construction have been earth-filled

cellular and double steel sheet pile retaining walls. However, their present use is limited because of the expense.

Dike Design

245. Dike design as the responsibility of the dredge contractor is undesirable. Retaining dikes and/or containment capacities provided by dredge contractors are often inadequate. Where design must be the responsibility of the dredge contractor or other private concern, it is recommended that diking plans and associated assumptions and computations be subject to CE inspection and approval.

246. Regardless of the simplicity in cross section envisioned necessary for a particular retaining dike, the dike should be designed by CE engineers and thorough field and laboratory investigations of foundations and construction materials should be conducted. Although design efforts are minimal in many cases, CE control of dike dimensions and alignment has helped to insure attainment of required capacity and tends to result in a more stable retaining dike.

247. CE design of retaining dikes has been more comprehensive for containment facilities planned for long-range disposal and future development or for those facilities located adjacent to agricultural, industrial, or populated areas. In such instances, extensive field and laboratory investigations and stability analyses are commonly conducted. Slope protection is normally provided when needed. Settlement analyses generally are not conducted since it is felt that dikes can be raised periodically as required.

248. Special consideration should be given to the design of embankment sections in the vicinity of sluices. Uncontrolled seepage through the embankment (and to a lesser degree the foundation) was noted to be the main cause of failures, and many of the failures were initiated by seepage along the soil-structure interface. Failures near sluice structures are particularly serious since pond depths are often the greatest in these areas.

249. Theoretical stability analyses should be conducted before

existing dikes are raised. Special consideration should be given to the stability of embankment sections located near riverbanks or other existing slopes. Existing embankment shear strengths should be determined and used in such stability analyses.

Dike Construction

250. Construction is often made difficult by generally poor foundation conditions and borrow materials. Confined disposal areas are often located on marshes or other tide inundated areas where foundations commonly consist of peats, soft organic clays and silts, or previously deposited, wet, fine-grained dredged material. Borrow materials, normally obtained from inside the disposal area and adjacent to the dike alignment, are often in a loose and wet state and have poor engineering properties. Such borrow materials are commonly placed at their natural moisture content, which is generally too high for good construction. Quality of borrow materials is generally somewhat better for construction of CE-designed dikes since a description of acceptable borrow materials is generally given in the contract specifications and borrow areas are sometimes designated on contract drawings.

251. The CE conducts limited inspection of dike construction due to a general lack of available personnel. Adequate inspection of dike construction has been provided only in special cases, such as disposal sites located in populated areas or in other instances when the consequence of failure was considered critical.

252. There is normally little effort expended in dike foundation preparation or treatment, although in some cases, clearing, grubbing, and stripping of the foundation are conducted. Dike construction on very weak foundations is commonly achieved through displacement of the soft deposits. An effective technique in some instances is to end-dump the fill and use a bulldozer to push the fill into the soft foundation. A reasonably firm foundation is ultimately established upon which retaining dike construction can continue.

253. Retaining dikes should be constructed in accordance with

detailed CE specifications concerning construction methods, materials, and dike alignment. The practice of allowing the dredge contractor to choose the size of the area to be diked should be eliminated except where subject to CE approval.

254. Fill placement with draglines followed by little or no compaction was prevalent in past retaining dike construction and is an undesirable practice. A semicompacted fill has been used by a few Districts as a means of obtaining a more stable retaining dike. In construction of a semicompacted fill, material is generally placed in layers at its natural moisture content and compacted to the maximum density obtainable by routing of hauling and spreading equipment.

255. More frequent efforts to improve foundation conditions through stripping or displacement of soft deposits by end-dumping fill are recommended. Embankment fill should be placed in layers and compacted by at least the selective routing of such construction equipment as scrapers and bulldozers. Saturated or very wet materials should be allowed to dry before placement. Stockpiling of wet borrow material for subsequent diking operations would probably significantly improve its engineering properties.

Dike Stability

256. Retaining dikes often require continual maintenance and, even with this, failures occur. Dike failures have been most common in unpopulated areas, where dike design is often minimal, and these failures have resulted in flow of dredged material onto tidal flats and marshes or into adjacent rivers and streams. The environmental impact of such failures is unknown. Dike failures also have caused damage to structures and even flooding of a residential area.

257. The recently expanded use of confined disposal areas and their encroachment on valuable lands and waters require that the frequency of retaining dike failures be reduced. A reduction in dike failures would lessen potential environmental harm and likely result in reduced dredging costs. In general, dredge contractors are not

reimbursed for dike maintenance or redredging of material lost through dike failures. However, since contractors are aware of diking difficulties, their bid estimates are likely inflated to cover expenses for redredging and dike maintenance.

258. Foundation conditions, construction methods and materials, and uncontrolled seepage are the main factors contributing to dike instability and failure. Retaining dikes founded on soft deposits are especially susceptible to foundation failures. Embankment shear strengths are often inadequate because of the high moisture content of borrow materials and the lack of compaction during placement. The effects of seepage are directly responsible for or contributed to the majority of retaining dike failures.

259. The increased use of polyethylene sheeting and exterior slope berms in retaining dike construction is encouraged. Properly designed and constructed, such features will undoubtedly in many instances improve dike stability and should be considered for use in weak or otherwise critical areas along the dike alignment. Indiscriminate placement of additional materials on dikes at locations where settlements or slides occur is undesirable and could result in major failures. A more appropriate action would be to halt disposal operations (or at least lower the pond depth) and then totally assess the problem before taking remedial action.

260. Drainage systems for the embankment and confined material should be considered in design. Embankment stability will be increased and the continued drainage of accumulated dredgings will increase containment capacities and improve the quality of the dredged material and the disposal site for subsequent use if drainage systems are effective.

261. Although contractors are generally responsible for inspection and maintenance of retaining dikes during dredging operations, dike failures nonetheless occur. In general, dike inspection clauses lack detail, and maintenance operations are not subject to CE approval.

262. More detailed specifications relating to disposal operations are needed to insure dike stability. Important features such as minimum

freeboard, discharge rates, and pipeline locations seldom have been specified.

263. Greater use of detailed contract specifications concerning inspection, dike maintenance, and control of discharge operations is recommended. Inspection procedures and frequency, equipment and material most likely needed for repair, and location and rate of discharge should be specified in the most detailed terms possible. The CE should consider the feasibility of conducting regular dike inspections and accepting the responsibility of dike maintenance during dredging in instances when dikes have been constructed to CE specifications.

LITERATURE CITED

1. Boyd, M. B. et al., "Disposal of Dredge Spoil, Problem Identification and Assessment and Research Program Development," Technical Report H-72-8, Nov 1972, U. S. Army Engineer Waterways Experiment Station, CE, Vicksburg, Miss.
2. Office, Chief of Engineers, Department of the Army, CE, "Disposal of Dredged Materials," Engineering Circular 1165-2-97, May 1971, Washington, D. C.
3. _____, "Disposal of Dredged Materials," Engineering Circular 1165-2-116, Aug 1972, Washington, D. C.
4. U. S. Army Engineer District, Philadelphia, CE, "Long-Range Spoil Disposal Study," Jun 1969, Philadelphia, Pa.
5. Windom, H. L., "Environmental Response of Salt Marshes to Deposition of Dredged Materials," Preprint 1612, Jan 1972, American Society of Civil Engineers National Water Resources Engineering Meeting, Atlanta, Ga.
6. U. S. Army Engineer District, Charleston, CE, "Spoil Disposal Study, Charleston Harbor, S. C.," Apr 1966, Charleston, S. C.
7. _____, "Review of Reports on Charleston Harbor, South Carolina (Interim Report on Long-Range Spoil Disposal Study)" (Preliminary Draft), Jul 1970, Charleston, S. C.
8. U. S. Army Engineer District, Norfolk, CE, "Notice of Public Meeting on Studies of Hampton Roads Channels, Virginia, and Craney Island Disposal Area, Norfolk Harbor, Va.," 28 Apr 1972, Norfolk, Va.
9. U. S. Army Engineer District, Chicago, CE, "Research Proposal, Chicago Dredge Disposal, Calumet Harbor Reclamation Project" (Preliminary Draft), Mar 1972, Chicago, Ill.
10. Stevens, Thompson, and Runyon, Inc., "Management of Dredge Spoils in Coos Bay, Interim Report, Coos-Curry Environmental Protection," Jan 1972.
11. U. S. Army Engineer District, Galveston, CE, "Sabine-Neches Waterway, Texas (40-Foot Project and Channel to Echo); Sabine Lake Spoil Disposal Areas," Design Memorandum No. 1, Supplement No. 2, Dec 1966, Galveston, Tex.
12. Huston, J., Hydraulic Dredging, Cornell Maritime Press, Cambridge, 1970, p. 256.
13. Office, Chief of Engineers, Department of the Army, CE, "Analysis of Consolidated Statement of Operations, Hopper and Sidecasting Dredges, Fiscal Year 1971," Mar 1972, Washington, D. C.
14. Horn, W. L., "Craney Island Disposal Area, 1954-1969," The Military Engineer, Vol 61, No. 403, Sep-Oct 1969, p. 359.

15. Thompson, T. L. et al., "Slurry Pumps - A Survey," The Canadian Mining and Metallurgical Bulletin, Vol 66, No. 729, Jan 1973, p. 103.
16. Starring, J. W., "Sand Fill Pumped 15 Miles for Interstate Construction," Civil Engineering, American Society of Civil Engineers, Vol 41, No. 2, Feb 1971, pp 44-46.
17. U. S. Army Engineer District, Mobile, CE, "Monitoring the McDuffie Island Spoil Disposal Area, Aug-Nov 1970," Mobile, Ala.
18. U. S. Army Engineer Division Laboratory, South Pacific, CE, "Final Report, Tests for Pollutants on Water Samples, Benecia Bridge, Stockton Port, Stockton Channel, and Calaveras River, Sacramento District," Mar 1972, Sausalito, Calif.
19. _____, "Analysis of Samples from Dredging of Sacramento Deep Water Ship Channel, Suisan Bay M18, Pittsburg (VIC) Site 5," Jan 1973, Sausalito, Calif.
20. U. S. Army Engineer District, Buffalo, CE, "Dredging and Water Quality Problems in the Great Lakes" (in 12 vols), Jun 1969, Buffalo, N. Y.
21. O'Neal, G. and Sceva, J., "The Effects of Dredging on Water Quality in the Northwest," Jul 1971, Environmental Protection Agency, Office of Water Programs, Region X, Seattle, Wash.
22. U. S. Army Engineer District, Chicago, CE, "Abatement of Objectionable Odors Produced by Contained Dredge Spoil" (Unpublished Report), Mar 1972, Chicago, Ill.
23. U. S. Army Engineer District, Galveston, CE, "Draft Environmental Statement, Houston Ship Channel, Texas (Maintenance Dredging)," Dec 1971, Galveston, Tex., p. 5.
24. California Regional Water Quality Control Board, Central Valley Region, "Waste Discharge Requirements for Freeport Bend Dredging (Division of Highways), Sacramento County," Order No. 73-23, Jul 1972, Oakland, Calif.
25. U. S. Army Engineer District, Charleston, CE, "Design Memorandum, Spoil Disposal Area, Daniel Island," Aug 1965, Charleston, S. C.
26. U. S. Army Engineer District, Norfolk, CE, "General Design Memorandum, Craney Island Disposal Area, Norfolk Harbor, Va.," Mar 1953 (Revised Nov 1953), Norfolk, Va.
27. U. S. Army Engineer District, Chicago, CE, "Letter Report on Confined Disposal Areas for Milwaukee and Port Washington Harbors, Wisconsin," Feb 1972, Chicago, Ill.
28. _____, "Letter Report on Confined Disposal Areas for Waukegan Harbor, Illinois," Jul 1972 and Oct 1972, Chicago, Ill.
29. U. S. Army Engineer District, Buffalo, CE, "Draft Environmental Statement, Diked Disposal Area, Buffalo River, Buffalo Harbor,

Black Rock Channel, Tonawanda Harbor, Erie County, New York,"
Nov 1972, Buffalo, N. Y.

30. Coastal Zone Resources Corporation, "Draft Environmental Statement Military Ocean Terminal, Sunny Point, North Carolina," prepared for U. S. Army Engineer District, Wilmington, North Carolina, 20 Mar 1972.
31. Office, Chief of Engineers, Department of the Army, CE, "Stability of Earth and Rock-fill Dams," Engineer Manual EM 1110-2-1902, Apr 1970, Washington, D. C.
32. Terzaghi, K. and Peck, R. B., Soil Mechanics in Engineering Practice, 1st ed., Wiley, New York, 1948.
33. Office, Chief of Engineers, Department of the Army, CE, "Earth and Rock-Fill Dams, General Design and Construction," Engineer Manual EM 1110-2-2300, Mar 1971, Washington, D. C.
34. U. S. Army Coastal Engineering Research Center, "Shore Protection Planning and Design," Technical Report No. 4, 3d ed., 1966, Fort Belvoir, Va.
35. U. S. Army Engineer District, Vicksburg, CE, "Vicksburg Harbor Project, General Design Memorandum," Design Memorandum No. 1, Feb 1956 (Revised Apr 1956), Vicksburg, Miss.
36. U. S. Army Engineer District, Wilmington, CE, "Specifications for Channel Improvement Project, Cape Fear River Above Wilmington, N. C.," Bid Invitation No. DACW54-68-B-0017, 18 Jun 1968, Wilmington, N. C.
37. U. S. Army Engineer District, Portland, CE, "Coos Bay, Oregon," Bid Invitation No. DACW57-71-B-0018, 11 Aug 1970, Portland, Oreg.
38. U. S. Army Engineer District, Charleston, CE, "Specifications for Maintenance Dredging of U. S. Naval Weapons Station Facility, Charleston Harbor, South Carolina, 35-Foot Project, and Shipyard River, S. C., 30-Foot Project," Specifications Serial No. DACW60-72-B-0008, 19 May 1972, Charleston, S. C.
39. _____, "Specifications for Construction of Dike, Charleston Harbor, South Carolina," Specifications Serial No. DACW60-68-B-0014, 1 Apr 1968, Charleston, S. C.
40. U. S. Army Engineer District, Philadelphia, CE, "Specifications for Construction of Disposal Areas Between Delaware City and Summit Bridge, Inland Waterway, Chesapeake and Delaware Canal, Delaware," Bid Invitation No. DACW61-70-B-0093, 22 Jun 1970, Philadelphia, Pa.
41. U. S. Army Engineer District, Galveston, CE, "Specifications for Repairs to Levees, Clinton Spoil Disposal Area in Harris County, Texas," Contract No. DACW64-67-C-0098, 24 May 1967, Galveston, Tex.
42. U. S. Army Engineer District, Galveston, CE, "Specifications for Maintenance Dredging Houston Ship Channel - Sims Bayou, to and

- Including Turning Basin," Bid Invitation No. DACW64-71-B-0115, 1971, Galveston, Tex.
43. U. S. Army Engineer District, Wilmington, CE, "Specifications for Construction of Upland Dredge Disposal Dike, Military Ocean Terminal, Sunny Point, N. C.," Amendment of Solicitation No. DACW54-72-B-0028, 3 May 1972, Wilmington, N. C.
 44. U. S. Army Engineer District, Charleston, CE, "Specifications for Construction of Dikes and Spillways, Atlantic Intracoastal Waterway, Winyah Bay to Charleston, South Carolina," Specifications Serial No. DACW60-72-B-0007, 12 May 1972, Charleston, S. C.
 45. U. S. Army Engineer District, Wilmington, CE, "Specifications for Construction of Upland Dredge Disposal Dike, Military Ocean Terminal, Sunny Point, North Carolina," Invitation No. DACW54-72-B-0028, 26 Apr 1972, Wilmington, N. C.
 46. Office, Chief of Engineers, Department of the Army, CE, "Laboratory Soils Testing," Engineer Manual EM 1110-2-1906, Nov 1970, Washington, D. C.
 47. Terzaghi, K. and Peck, R. B., Soil Mechanics in Engineering Practice, 2nd ed., Wiley, New York, 1967.
 48. U. S. Army Engineer District, Seattle, CE, "Specifications for Maintenance Dredging, Swinomish Channel, Washington," Contract No. DACW67-72-C-0034, 10 Nov 1971, Seattle, Wash.
 49. U. S. Army Engineer District, Wilmington, CE, "Specifications for Maintenance Dredging in Wilmington Harbor, N. C. (38-Foot Project)," Bid Invitation No. DACW54-72-B-0017, 24 Jan 1972, Wilmington, N. C.
 50. U. S. Army Engineer District, Philadelphia, CE, "Specifications for Maintenance Dredging in Wilmington Harbor, Delaware," Bid Invitation No. DACW61-70-B-0055, 18 Mar 1970, Philadelphia, Pa.
 51. U. S. Army Engineer District, Mobile, CE, "Specifications for Maintenance Dredging of Mobile River Channel, Mobile County, Alabama," Specification Serial No. DACW01-71-B-0141, 3 Jun 1971, Mobile, Ala.
 52. U. S. Army Engineer District, Charleston, CE, "Specifications for Lease of Equipment, with Operating Personnel for Repair of the Sampit River Disposal Area Dike, Georgetown, South Carolina," Specification Serial No. DACW60-73-B-0001, 30 Jun 1972, Charleston, S. C.

Table 1

Stability Analyses for Retaining Dikes

District	Facility or Situation	Stability Analysis*			Shear Strength Data	Dike Cross Section	Year Constructed
		Type	Cases	Factor of Safety			
Philadelphia	High dikes and/or known foundation problems	CA,W	EC,SS	1.2	Embankment: Estimated Foundation: In situ vane shear		
Galveston	Failure will flood populated areas	CA,W	EC	1.2	Embankment: Estimated Foundation: Split-spoon penetration		
	Sabine Lake	CA,W	EC	1.2	Embankment: Estimated Foundation: Q-tests (undisturbed samples)	Fig. 24	1967
Wilmington	Military Ocean Terminal	CA,W	EC,SS	1.1	Embankment: R-test (compacted samples) Foundation: Q- & R-tests (undisturbed samples)	C-6**	1972
Norfolk	Craney Island	CA,W	EC	1.9	Embankment: Estimated Foundation: Q-tests (undisturbed samples)	Fig. 26	1954
Charleston	Daniel Island	CA,W	EC	1.0	Embankment: Estimated Foundation: Split-spoon penetration	Fig. 25	1966
Detroit	Common procedure	CA,W	EC	1.2	Embankment: Estimated or Q-test (compacted samples) Foundation: In situ vane shear or Q-test (undisturbed samples)		
Chicago	Milwaukee Harbor	W	EC	1.5	Embankment: Estimated Foundation: Q-tests (undisturbed samples)	Fig. 27	
Buffalo	Cleveland Harbor and Buffalo Harbor	CA,W	EC	1.2	Embankment: Estimated Foundation: In situ vane shear	Fig. 29 Fig. 30, 31	1967, 1968 1968, 1970

* Methods are given in CE Engineer Manual EM 1110-2-1902, "Stability of Earth and Rock-fill Dams." These are denoted herein as follows: CA-circular arc method, W-wedge method, EC-end of construction case, and SS-steady seepage case.

** As numbered in Appendix C.

Table 2
Construction Costs for Land-Based Retaining Dikes

Dike Identification (As Numbered in the Appendixes)	District	Vol Enclosed (Avg Dike Height x Area Enclosed) cu yd	Dike Length, ft	Total Cost dollars	Cost per Cubic Yard of Volume Enclosed dollars	Cost per Linear Foot of Dike dollars	Year Cost Determined	Remarks
B-2	Charleston	5,000,000	17,300	54,000	0.01	3.12	1972	Dike raising. CE estimate. Includes drainage facilities
C-10	Mobile	15,000,000	9,200	202,000	0.01	22.00	1971	Actual cost
A-6	Philadelphia	6,000,000	17,600	110,000	0.02	6.30	1970	Dike raising. CE estimate
A-5	Norfolk	100,000	3,000	1,800	0.02	0.60	1972	CE estimate
B-3	Charleston	3,500,000	16,000	72,000	0.02	4.50	1972	Dike raising. Bid estimate
C-3	Galveston	7,400,000	20,700	228,000	0.03	11.00	1967	Dike raising. Bid estimate. Includes drainage facilities
C-1	Vicksburg	13,000,000	23,690	450,000	0.04	19.00	1956	CE estimate. Includes drain- age facilities
C-2	Galveston	3,300,000	13,500	135,000	0.04	10.00	1963	Dike raising. Bid estimate. Includes drainage facilities
C-5	Charleston	4,000,000	50,000	170,000	0.04	3.40	1972	Dike raising. CE estimate. Six separate areas. In- cludes drainage facilities
C-9	Sacramento	1,000,000	4,700	47,000	0.05	10.00	1965	Bid estimate
C-6	Wilmington	16,000,000	20,000	1,620,000	0.10	81.00	1972	Actual cost. Includes drain- age facilities
C-4	Charleston	8,000,000	23,000	850,000	0.11	37.00	1968	Actual cost. Includes drain- age facilities
C-8	Detroit	10,000,000	8,700	1,056,000	0.11	122.00	1969	Dike raising. Actual cost

Table 3
Construction Costs for In-Water Retaining Dikes

Dike Identification (As Numbered in the Appendixes)	District	Vol Enclosed (Avg Dike Height x Area Enclosed) cu yd	Dike Length, ft	Total Cost dollars	Cost per Cubic Yard of Volume Enclosed dollars	Cost per Linear Foot of Dike dollars	Year Cost Determined	Remarks
D-1	Galveston	87,000,000	51,700	7,000,000	0.08	133.00	1967	CE estimate. Includes drain- age facilities
D-3	Norfolk	71,000,000	31,700	6,600,000	0.09	208.00	1954	Actual cost. Includes drain- age facilities
D-2	Charleston	12,000,000	17,300	1,670,000	0.14	97.00	1966	Bid estimate. Includes drain- age facilities
D-6	Buffalo	564,000	1,100	210,000	0.37	190.00	1970	Actual cost
D-9	Buffalo	6,600,000	7,400	6,000,000	0.91	810.00	1972	CE estimate. Proposed facility
D-5	Buffalo	490,000	1,900	566,000	1.20	300.00	1968	Actual cost
D-4	Buffalo	1,750,000	4,100	2,700,000	1.50	659.00	1968	Actual cost
D-7	Chicago	1,600,000	3,500	5,900,000	3.70	1680.00	1972	CE estimate. Proposed facility. Includes embank- ment dike, cellular steel sheet pile structure, and drainage facilities
D-4	Buffalo	373,000	2,200	1,400,000	3.80	635.00	1967	Actual cost
D-8	Chicago	750,000	3,600	4,690,000	6.30	1300.00	1972	CE estimate. Proposed facility. Includes embank- ment dike, cellular steel sheet pile structure, and drainage facilities

APPENDIX A: LAND-BASED EARTH DIKES DESIGNED
AND CONSTRUCTED UNDER DREDGING CONTRACTS

DIKE DESCRIPTION A-1

1. Dikes involved. Numerous retaining dikes within the New Orleans District.
2. Design responsibility. Dredge contractor.
3. Construction responsibility. Dredge contractor.
4. Foundation. Marsh deposits of peats and soft organic clays and silts.
5. Dike material. Dredged material consisting of saturated fine sands and silts obtained from within the disposal area.
6. Cross section. Height, 2 to 8 ft; crown width, 4 ft; slope, 1V on 4H.
7. Construction. Fill placed by dragline with no compaction; hydraulic fill.
8. Special features. Interior slopes are sometimes lined with polyethylene sheeting (at the dredge contractor's discretion). In many cases, the dredge contractor can choose to dike all or only a portion of the area designated for disposal.
9. Failures. Foundation failures have been common. Dikes have often required continual maintenance.

DIKE DESCRIPTION A-2

1. Dike involved. Retaining dike for a containment facility at McDuffie Island,¹⁷ Mobile District.
2. Design responsibility. Dredge contractor.
3. Construction responsibility. Dredge contractor.
4. Foundation. Dredged material (fine silts) and marsh deposits.
5. Dike material. Dredged material of saturated fine silts obtained from within the disposal area.
6. Construction. Fill was placed by dragline with no compaction. Draglines were barge-mounted or placed on timber mats. Large settlement and caving occurred in some areas shortly after construction. To attain the desired dike height, material was backfilled behind a vertical plywood wall placed along the dike center line.
7. Design investigations. For the described case, there have been few, if any, investigations; however, in a report prepared by the CE concerning this job,¹⁷ it was recommended that in the future: (a) dikes should be constructed and maintained under separate contracts, (b) detailed subsurface investigations should be conducted in order to properly design dikes, and (c) there should be a general review and possible clarification of contract specifications pertaining to spoil disposal and these specifications should be strictly enforced.
8. Failures. The dike failed at a number of locations during the disposal operations. A portion of the dike was restored by hydraulic fill with material obtained from well below the required depth of dredging. Approximately 322,000 cu yd of dredged material was used in dike repair, and over 600,000 cu yd of material was lost through dike failures. Pond depth was lowered to stabilize the dike, which resulted in another 500,000 cu yd of material being lost over the weir. In effect, 57 percent of the material dredged escaped from the confined area.

DIKE DESCRIPTION A-3

1. Dikes involved. Numerous retaining dikes within the Savannah District.
2. Design responsibility. Dredge contractor.
3. Construction responsibility. Dredge contractor.
4. Foundation. Dredged material and marsh deposits.
5. Dike material. Dredged material consisting of saturated silty sand obtained from within the disposal area.
6. Cross section. Height, 4 to 6 ft; crown width, 8 ft; slope, 1V on 2H; except for hydraulic construction, which has yielded slopes as flat as 1V on 30H.
7. Construction. Fill was placed by dragline with no compaction. The borrow ditch was kept 50 or 60 ft from the dike center line to avoid disturbance of the stiff marsh mat which supports the dike. Initial construction on marsh deposits has been accomplished through placement of hydraulic sand fill followed by reworking with fine silt by dragline. A base width of 150 to 200 ft is common. A wide base is needed to avoid "mat breakthrough." The mat is a stiff layer reinforced with a network of roots which overlies much softer deposits. Generally about 3 ft of settlement occurs during or shortly after construction. An additional 3 ft of settlement occurs during the first 5 yr after construction.
8. Design investigations. Recently, this District has specified minimum dike dimensions in contracts. Sites are visually inspected, and possibly a few disturbed sample borings are made within the disposal area. Selected minimum dike dimensions are then based on past experience with similar borrow materials and foundations.
9. Special features. Interior slopes have occasionally been lined with polyethylene sheeting (at the dredge contractor's discretion). In many cases, the dredge contractor has been allowed to choose to dike all or only a portion of the area designated for disposal.
10. Failures. Retaining dike failures have been common. Excessive seepage through and beneath dikes has been a problem. High discharge rates have also caused dike interior erosion and overtopping (such a failure resulted in damage to a railroad embankment).
11. Comment. Seepage has been a special problem since areas must be left ponded for mosquito control.

DIKE DESCRIPTION A-4

1. Dikes involved. Numerous retaining dikes within the Wilmington District.
2. Design responsibility. Dredge contractor.
3. Construction responsibility. Dredge contractor.
4. Foundation. Marsh and swamp deposits; dredged material of sand, silt, and clay (variable organic content).
5. Dike material. Dredged material consisting of saturated silts obtained from within the disposal area. Exact location of borrow ditch is generally not specified; however, in some cases, it has been specified that mounded dredged material in the center of the disposal area will be used as dike fill.
6. Cross section. Height, 4 to 6 ft; crown width, 6 ft; slope, 1V on 1.5 to 2H.
7. Construction. Fill was placed by dragline with some shaping by bulldozer. If caving occurred, dike construction was discontinued in the unstable area. After some time, fill placement continued. Construction has often been slow, but ultimately the dikes have been established. In one case, a berm was placed over a heaved area to achieve stabilization.
8. Design investigations. Recently, this District has specified minimum dike dimensions in contracts. Selected dike dimensions are based on a visual inspection of the site combined with past experience.
9. Special features. The dredge contractor has often been required to inspect dikes once each 8 hr during disposal operations.
10. Failures. Most failures have been minor. In one case, some warehouses were damaged as a result of a dike failure. Problems have been caused by (a) interior slope erosion caused by high-velocity discharge, (b) seepage through dikes, and (c) animal burrows initiating excessive seepage and piping through the dike.

DIKE DESCRIPTION A-5

1. Dike involved. Retaining dike for a containment facility in the Norfolk District.
2. Design responsibility. Dredge contractor.
3. Construction responsibility. Dredge contractor.
4. Foundation. Sand, silt.
5. Dike material. Sand, silt (some borrow areas containing organic material). Material was fairly dry and was obtained from within the disposal area.
6. Cross section. Height, 5 to 6 ft; crown width, 2 to 3 ft; slopes, 1V on 1H.
7. Construction. Fill was placed by dragline with no compaction.
8. Special features. A portion of dike is located about 10 to 12 ft from a highway and opposite a shopping center. No problems during disposal are envisioned since coarse sand and gravel will be discharged into the area from a 12- to 14-in.-diam pipe. Rapid settling of solids is expected.
9. Comment. Dragline-constructed dikes that are designed and built by the dredge contractor are common in this area where marsh, dredged material, and sand foundations are prevalent. There have been no recent failures, but seepage has been a problem (sometimes initiated by muskrat holes). Interior dike slopes are in some cases lined with polyethylene sheeting.

DIKE DESCRIPTION A-6

1. Dike involved. Retaining dike for a containment facility in the Philadelphia District.
2. Design responsibility. Dredge contractor.
3. Construction responsibility. Dredge contractor.
4. Foundation. Dredged material (silt and some clay) underlain by marsh deposits.
5. Dike material. Clayey silt obtained from within the disposal area.
6. Cross section. Height, interior--8 ft, exterior--12 ft; crown width, 4 ft; slopes, 1V on 1.5H. Existing dike was incorporated into new dike construction.
7. Construction. Fill was placed by dragline with no compaction.
8. Failures. A 150-ft-long section failed during disposal operations. High pore water pressures due to seepage through the dike were considered to have caused the failure. It appeared to be a shear failure of the embankment and not a foundation failure.
9. Comment. The CE designed and specified construction procedures for dike reconstruction.

DIKE DESCRIPTION A-7

1. Dike involved. Retaining dike for a containment facility in the Philadelphia District.
2. Design responsibility. Dredge contractor.
3. Construction responsibility. Dredge contractor.
4. Foundation. Dredged material (silty sand) underlain by tidal marsh deposits of organic silty clays.
5. Dike material. Dredged material consisting of silty sand obtained from within the disposal area.
6. Cross section. Height, 6 to 10 ft; crown width, 4 to 6 ft; slopes, 1V on 1.5H. Existing dike was incorporated into new dike construction.
7. Construction. Fill was placed by dragline with no compaction.
8. Failure. Foundation shear failure caused 50-ft-wide breaks in the dike at two locations. One failed section was located very near the sluice structure, and the other involved the sluice structure. The sluice structure settled 9 ft and moved horizontally outward a distance of 6 ft.
9. Comment. The CE designed and specified construction procedures for dike reconstruction.

DIKE DESCRIPTION A-8

1. Dike involved. Retaining dike for a containment facility in the Philadelphia District.
2. Design responsibility. Dredge contractor.
3. Construction responsibility. Dredge contractor.
4. Foundation. Tidal marsh (organic silty clay, peats).
5. Dike material. Silty sand obtained from a nearby borrow area located outside the disposal area.
6. Cross section. Cross dike: height, 30 ft; crown width, 10 to 15 ft; slope, 1V on 2H. Lower area retaining dike: height, 21 ft; crown width, 8 ft; slope, 1V on 1.5H.
7. Construction. Fill was end-dumped and pushed into the foundation by bulldozer. An adequate foundation or base section was established after displacing a 6- to 10-ft thickness of the soft organic silty clay and peat deposits. Embankment fill was placed in 12-in.-thick layers and compacted by routing of such hauling and spreading equipment as trucks, scrapers, and bulldozers.
8. Special features. The cross dike contained buried pipes near its crest, which allowed spillage into a lower area surrounded by a retaining dike.
9. Failures. The cross dike washed out near the outfall pipes. The surge of dredged slurry then overtopped and washed out a section of the lower area retaining dike. Seepage through vertical transverse cracks at the base of the dike and subsequent piping were thought to have caused failure of the cross dike. The transverse cracks were formed by differential settlement of the base section.

DIKE DESCRIPTION A-9

1. Dike involved. Retaining dike for a containment facility in the Buffalo District.
2. Design responsibility. Dredge contractor.
3. Construction responsibility. Dredge contractor.
4. Foundation. Clay.
5. Dike material. Predominantly clay obtained from inside the disposal area.
6. Cross section. Height, 6 ft; crown width, 4 ft; slopes, 1V on 1.5H.
7. Construction. Fill was placed by dragline followed by some compaction by bulldozer. Clearing at the dike base and removal of topsoil were required in dredging contract specifications.
8. Special features. Topsoil removed from dike base was to be redistributed along the outer face and top of the dike to aid in later seeding.

DIKE DESCRIPTION A-10

1. Dikes involved. Retaining dikes for three containment facilities in the Portland District.
2. Design responsibility. Dredge contractor.
3. Construction responsibility. Dredge contractor.
4. Foundation. Dredged material underlain by natural silt deposits.
5. Dike material. Two of the dikes were constructed of a silty sand containing shells. The third dike was constructed of silty clay. Materials were obtained from within the disposal area.
6. Cross section. Silty sand dikes: height, 8 to 10 ft; crown width, 2 ft; slopes, 1V on 2H. Silty clay dike: height, 10 to 12 ft; crown width, 3 ft; slopes, 1V on 3 to 5H.
7. Construction. Fill was placed by dragline with no compaction.
8. Failures. Rotted wooden sluices along the silty clay dike collapsed or were damaged, and erosion occurred at the dike-sluice interface. One sluice was completely washed out. Dredged slurry and debris flooded the adjacent tidal flats.
9. Comment. These failures led to the inspection of other sluices in the area. Much of the wood in these was also found to be rotted.

DIKE DESCRIPTION A-11

1. Dikes involved. Retaining dikes for two containment facilities in the Seattle District.
2. Design responsibility. Dredge contractor.
3. Construction responsibility. Dredge contractor.
4. Dike material. Dike 1: wet clay containing sod and roots. Dike 2: silty sand.
5. Cross section. Dike 1: height, 4 to 5 ft; slopes, 1V on 2H. Dike 2: height, 15 to 20 ft; slopes, 1V on 2H; crown width, 2 to 3 ft.
6. Construction. Dike 1 fill was pushed in place by bulldozer. The initial 8 ft of height of dike 2 was placed by scraper; remaining height was placed by dragline with no compaction.
7. Failures. Dike 1: a small section of the dike failed, and dredge slurry emptied on private land. It was expected that the landowner would require some compensation. At the time of failure, the dike fill was very wet and soft. Just prior to failure, a CE inspector sank to a depth of about 1 ft at several locations on the dike.

DIKE DESCRIPTION A-12

1. Dike involved. Retaining dike for a containment facility in the Chicago District.
2. Design responsibility. Private contractor for local interest.
3. Construction responsibility. Private contractor for local interest.
4. Foundation. Swamp with sand at a depth of 3 to 4 ft.
5. Dike material. Sandy silt and some clay.
6. Cross section. Height, 6 to 15 ft; crown width 6 to 10 ft.
7. Construction. Fill was placed by dragline or pushed up by bulldozers.
8. Failures. Minor dike washouts resulted from the erosion of interior slopes caused by high discharge rates in such a small area.
9. Comment. Other similar dikes have failed due to excessive seepage and subsequent piping at the embankment-foundation contact. Such seepage is the result of constructing the dike on existing vegetation.

APPENDIX B: LAND-BASED EARTH DIKES DESIGNED BY THE
CE AND CONSTRUCTED UNDER DREDGING CONTRACTS

DIKE DESCRIPTION B-1

1. Dikes involved. Numerous retaining dikes within the Galveston District.
2. Design responsibility. The CE specified required minimum dimensions.
3. Construction responsibility. Dredge contractor.
4. Foundation. Marsh (soft clays) and dredged material consisting of sandy silts.
5. Dike material. Clays and silty sands obtained from within the disposal area. It is generally required that a minimum berm length of 15 to 30 ft be left between the interior toe of the dike and the borrow area.
6. Cross section. Maximum height, 10 ft; crown width, 4 to 8 ft; slopes, 1V on 2 to 4H.
7. Construction. Dikes were constructed in 2- to 4-ft increments at intervals of 3 to 4 yrs. Materials were generally placed by dragline with possibly some compaction by bulldozers. It was generally necessary to allow the fill to sink into and displace the soft deposits to form an adequate subsurface foundation. In a few cases where good foundation conditions exist, a semicompacted fill has been constructed as follows: (a) embankment materials are obtained from within the disposal area, and vegetation, debris, and other objectionable material are removed; (b) the foundation is cleared, grubbed, and in some cases stripped; (c) fill is placed at its natural moisture content, spread in 12-in. layers, and compacted with crawler tractors or in some cases more specialized tamping rollers; and (d) where possible, the more impervious materials are placed toward the interior slope.
8. Design investigations. Field: disturbed sample borings along dike alignments and in proposed borrow areas; split-spoon penetration resistance tests. Laboratory: water content determinations and visual classification; precise classification of representative samples; pocket penetrometer tests. Results of the field and laboratory investigations were generally combined with past experience to select required dike dimensions. If the dike was adjacent to a populated area, stability analyses (circular arc or wedge method) were conducted. End of construction case was analyzed, and a minimum factor of safety of 1.2 was required. Embankment shear strengths were estimated from tests of similar materials used in construction of flood protection levees. Foundation shear strength was estimated from results of split-spoon penetration resistance tests.
9. Special features. Dike slopes are generally seeded immediately following construction. In some marsh areas, vegetation grows rapidly without any special seeding efforts. The root system has been noted to be very deep within the embankment. Interior slopes are in some cases lined with polyethylene sheeting prior to disposal operations. The polyethylene sheeting is placed in vertical strips, and joints are sealed with pressure-sensitive tape.

DIKE DESCRIPTION B-2

1. Dike involved. Retaining dike for a containment facility at Daniel Island, Charleston District.
2. Design responsibility. CE.
3. Construction responsibility. Dredge contractor.
4. Foundation. Dredged material consisting of silty sand and shells overlying soft organic clay.
5. Dike material. Silty sand and shell from within the containment area. Borrow area was restricted to a minimum distance of 40 ft from the new dike center line, which put the borrow ditch at about 5 ft from the interior toe. It was stipulated in the dredging contract that dike material would not contain roots, grass, and other organic matter.
6. Cross section. Height of dike raising, 3 to 4 ft; crown width, 10 ft; slopes, 1V on 2H.
7. Construction. Fill was placed by dragline with no compaction. Existing dike was incorporated into new dike construction.
8. Design investigations. Mainly, experience with construction of the existing retaining dike was relied upon.

DIKE DESCRIPTION B-3

1. Dike involved. Retaining dike for a containment facility in the Charleston District.
2. Design responsibility. The CE specified required minimum dimensions.
3. Construction responsibility. Dredge contractor.
4. Foundation. Dredged material consisting of silty sand and clay overlying soft marsh deposits.
5. Dike material. Sandy silt obtained from excavation of exterior drainage ditches or borrow from within the disposal area at a minimum distance of 40 ft from the dike center line. It was stipulated that the borrow material would not contain an excess of grass, roots, and other organic material. Suitability of borrow was determined by the contracting officer while construction was in progress.
6. Cross section. Exterior height, 10 to 15 ft; interior height, 3 to 5 ft; crown width, 8 ft; slopes, 1V on 1.5H. Dimensions include existing dikes which were incorporated into new dike construction.
7. Construction. Fill was placed by dragline with no compaction. Before construction, the dike foundation was cleared of trees, stumps, roots, brush, and other vegetation.
8. Design investigations. Selection of required minimum dimensions was based on past experience and a visual inspection of the disposal area to determine available borrow materials.
9. Failures. (a) A 300-ft length of dike failed prior to dredging operations. It was noted that the riverbank, located about 60 ft from the dike's exterior toe, displaced laterally approximately 25 ft. The failure apparently was a foundation shear failure (spreading failure). (b) A 200-ft length of dike failed after the disposal area was filled. The dredged material escaped into an adjacent river. The failure was likely caused by a reduction in shear strength due to high pore water pressures created by seepage through the embankment.
10. Comment. The 200-ft-long section which failed was repaired by constructing a new dike at a distance 130 ft closer to the interior of the disposal area. The new dike was constructed to a height of 9 ft with a 10-ft crown width. Six-foot-wide and 3- to 5-ft-thick berms were constructed at the base of both the interior and the exterior slopes. The new dike was constructed under CE supervision with leased equipment and hired operating personnel. A similar dike reconstruction was conducted by the dredge contractor after failure of the 300-ft-long section.

DIKE DESCRIPTION B-4

1. Dike involved. Retaining dike for a containment facility in the Philadelphia District.
2. Design responsibility. CE.
3. Construction responsibility. Dredge contractor.
4. Foundation. Dredged material (silt and some clay) underlain by marsh deposits.
5. Dike material. Silt and clay free of organic material and obtained from within the disposal area.
6. Cross section. Height, 10 to 12 ft; crown width, 8 ft; slopes, 1V on 1.5H.
7. Construction. Fill was placed in 1-ft layers and compacted by routing of hauling equipment.
8. Comment. This dike was constructed a short distance inward from the existing dike, which had failed. Portions of the existing dike were incorporated into new dike construction.

DIKE DESCRIPTION B-5

1. Dike involved. Retaining dike for a containment facility in the Philadelphia District.
2. Design responsibility. CE.
3. Construction responsibility. Dredge contractor.
4. Foundation. Dredged material (silty sand) underlain by tidal marsh deposits of organic silty clays.
5. Dike material. Dredged material (silty sand) free of organic material and obtained from within the disposal area.
6. Cross section. Height, 10 ft; crown width, 10 ft; slopes, 1V on 1.5H.
7. Construction. Material was placed and spread in 1-ft layers and compacted by routing of hauling equipment. The dike foundation was cleared and grubbed.
8. Comment. This dike was constructed a short distance inward from the existing dike, which had failed.

DIKE DESCRIPTION B-6

1. Dikes involved. Numerous retaining dikes within the Jacksonville District.
2. Design responsibility. The CE specified required minimum dimensions.
3. Construction responsibility. Dredge contractor.
4. Foundation. Some marsh areas overlain by dredged material (clayey sands, silty sands), but more recently only good sand foundations.
5. Dike material. Dredged material (silty sands, clayey sands) obtained from within the disposal area.
6. Cross section. Height, 5 to 15 ft; crown width, 5 to 15 ft; slope, 1V on 2 to 3H, except for hydraulic construction which has yielded 1V on 10 to 30H.
7. Construction. Fill was cast in place by dragline or dumped in place by truck. In a few cases, portions of the dikes were constructed by hydraulic fill during the actual dredging operation.
8. Design investigations. Field: visual inspection of site with possibly some disturbed sample borings within disposal area and along the dike alignment; split-spoon penetration resistance tests; visual classification of soils. Laboratory: primarily, visual classification of material samples and water content determinations. Selected dike dimensions were based on past experience with similar construction materials and foundations. No further design studies have been needed since construction materials and foundations are generally of good engineering quality.
9. Comment. Dikes built by contractors hired by local interests must meet CE-specified minimum dimensions.

DIKE DESCRIPTION B-7

1. Dikes involved. Numerous retaining dikes within the Philadelphia District.
2. Design responsibility. CE.
3. Construction responsibility. Dredge contractor.
4. Foundation. Dredged material, marsh deposits.
5. Dike material. Generally, sands or silts obtained from within the disposal area. It is required that borrow material be free of organic materials such as peat and sod.
6. Cross section. Height, 8 to 15 ft; maximum height, 20 to 30 ft; crown width, 10 ft; slopes, 1V on 2 to 5H and as gentle as 1V on 8H where hydraulic construction is used.
7. Construction. Clearing and grubbing of foundation. Ground surface under embankment was broken to facilitate bonding with embankment fill. Material was placed in 1-ft layers and compacted by routing of hauling and spreading equipment or a crawler tractor. If material was too wet to support compaction equipment, it was placed on the dike and allowed to dry before compaction. On very soft deposits, an adequate foundation for the embankment was constructed by displacing the soft foundation materials by end-dumping uniformly distributed loads of fill. The foundation was considered adequate when it would support hauling equipment used for placement and compaction of subsequent layers. In certain cases, the embankment was constructed in two stages. The successive stages are placed at 90-day intervals to allow for dike settlement. Exterior slopes are riprapped where necessary.
8. Design investigations. Field: disturbed and undisturbed sample borings; spoon penetration resistance tests; in situ vane shear tests. Laboratory: visual classification and water content determinations; precise classification of representative samples; triaxial shear tests (Q-tests) of undisturbed foundation samples. Stability analyses were conducted for dikes founded on very weak deposits and for those near populated areas. Circular arc and wedge analyses were conducted, and a minimum factor of safety of 1.2 was required. Embankment shear strengths were conservatively estimated, while foundation strengths were determined from the in situ vane shear tests. End of construction and steady seepage cases were analyzed.
9. Special features. Dikes were seeded immediately following construction. Interior slopes were in some cases lined with polyethylene sheeting prior to disposal operations.
10. Comment. Many confined disposal areas in the Philadelphia District are located near industrialized and other populated areas.

APPENDIX C: LAND-BASED EARTH DIKES DESIGNED BY THE CE
AND CONSTRUCTED UNDER SEPARATE CONTRACTS

DIKE DESCRIPTION C-1

1. Dike involved. Retaining dike for an industrial fill project associated with the Vicksburg Harbor Project, Vicksburg District.³⁵
2. Design responsibility. CE.
3. Construction responsibility. Private contractor.
4. Foundation. Channel fill and point bar deposits of clays and silts.
5. Dike material. Clays and some silts from selected borrow areas.
6. Cross section. (See fig. 33 of main text.)
7. Construction. Fill was placed primarily by end-dumping, with shaping and some compaction by bulldozer.
8. Design investigations. Field: disturbed and undisturbed sample boring, split-spoon penetration resistance tests. Laboratory: visual classification and water content determinations; precise classification of representative samples; direct shear tests (unconsolidated-undrained), triaxial shear tests (Q-tests), and unconfined compression tests of undisturbed samples. Stability analysis (circular arc) was conducted for retaining dike and industrial fill. Failure arcs were located largely within the foundation. The retaining dike and industrial fill was assumed to have no shear strength. The minimum factor of safety was computed to be 1.28 under rapid drawdown conditions.
9. Special features. An internal drainage system was constructed at points along the inside toe of the dike (see figs. 33 and 34). The drainage system has been effective.
10. Failures. Numerous interior slope failures occurred prior to filling. It was expected that the interior slopes would fail prior to placement of the industrial fill.

DIKE DESCRIPTION C-2

1. Dike involved. Retaining dike for a containment facility in the Galveston District.
2. Design responsibility. CE.
3. Construction responsibility. Private contractor.
4. Foundation. Soft to stiff clays with some silts and sands.
5. Dike material. Dredged material of sandy clay obtained from within the disposal area. Borrow area was specified on the contract drawings.
6. Cross section. Interior height, 6 to 10 ft; exterior height, 15 to 25 ft; crown width, 8 ft; slopes, 1V on 3H. Existing dikes were incorporated into new dike construction.
7. Construction. Semicompacted fill: materials were borrowed from within the disposal area. Foundation was cleared and grubbed. Fill was placed at natural moisture content, spread in 12-in. layers, and compacted with crawler tractors.
8. Design investigations. Field: disturbed sample borings along the dike alignment and in proposed borrow area; split-spoon penetration resistance tests. Laboratory: water content determinations and visual classification; precise classification of representative samples; pocket penetrometer tests. Stability analyses (circular arc or wedge method) were conducted. End of construction case was analyzed, and a minimum factor of safety of 1.2 was required. Embankment shear strength was estimated from tests of similar materials used in construction of flood protection levees. Foundation shear strength was estimated from results of split-spoon penetration resistance tests.
9. Failures. Five years after this construction, a slope failure occurred during disposal operations. Excessive pore water pressures due to seepage caused the failure which resulted in flooding of a nearby subdivision. The failed section had been constructed of sandy silts. During the repair, slopes were reduced to 1V on 6H.

DIKE DESCRIPTION C-3

1. Dike involved. Retaining dike for a containment facility in the Galveston District.
2. Design responsibility. CE.
3. Construction responsibility. Private contractor.
4. Foundation. Dredged material of silt, sand, and clay.
5. Dike material. Clay and clayey sand obtained from designated borrow areas within the disposal area.
6. Cross section. Exterior height, 17 ft; interior height, 10 ft; crown width, 8 ft; slopes, 1V on 3H. Existing dikes were incorporated into new dike construction.
7. Construction. Semicompacted fill: materials were borrowed from within the disposal area. Foundation was cleared and grubbed. Fill was placed at natural moisture content, spread in 12-in. layers, and compacted with crawler tractors.
8. Design investigations. Field: disturbed sample borings along dike alignment and in proposed borrow area; split-spoon penetration resistance tests. Laboratory: water content determinations and visual classification; precise classification of representative samples; pocket penetrometer tests. Results of the field and laboratory investigations were combined with past experience to select required dike dimensions.

DIKE DESCRIPTION C-4

1. Dike involved. Retaining dike for a containment facility at Morris Island, Charleston District.
2. Design responsibility. CE.
3. Construction responsibility. Private contractor.
4. Foundation. Soft organic silt and clay (low marsh area).
5. Dike material. Fine silty sand with a high organic clay and shell content was obtained from specified borrow area within the containment area. Material unsuitable for dike construction was deposited in another portion of the containment area.
6. Cross section. (See fig. 38 of the main text.)
7. Construction. Hydraulic fill followed by shaping with bulldozers.
8. Design investigations. Field: disturbed sample borings; split-spoon penetration resistance tests. Laboratory: visual classification and water content determinations; precise classification of representative samples.

DIKE DESCRIPTION C-5

1. Dikes involved. Retaining dikes for six containment facilities, Charleston District.
2. Design responsibility. The CE specified required minimum dimensions.
3. Construction responsibility. Private contractor.
4. Foundation. Dredged material of silty sand and clay overlying soft marsh deposits.
5. Dike material. Sandy silt was obtained from excavation of exterior drainage ditches or borrowed from within the disposal area at a minimum distance of 40 ft from the dike center line. It was stipulated that the borrow material not contain an excess of grass, roots, and other organic material. Suitability of borrow was determined by the contracting officer.
6. Cross section. Height, 5 to 10 ft; crown width, 10 ft; slopes, 1V on 1.5H.
7. Construction. Fill was placed by dragline with no compaction. In wet areas, draglines were mounted on pontoons. The crawler track around the pontoons provided a paddle for movement in water and deep tread for movement on soft ground. Before construction, the dike foundation was cleared of trees, stumps, roots, brush, and other vegetation.
8. Design investigations. Selection of dike dimensions was based on past experience and a visual inspection of the containment area to determine available borrow materials.
9. Comment. In general, existing dikes were incorporated into new dike construction; however, in some cases, interior dikes were constructed.

DIKE DESCRIPTION C-6

1. Dike involved. Retaining dike for the containment facility at the Military Ocean Terminal at Sunny Point, North Carolina, Wilmington District.
2. Design responsibility. CE.
3. Construction responsibility. Private contractor.
4. Foundation. The dike traverses two main foundation types: (a) dredged materials consisting of clay, silt, and sandy soils of varying organic content, (b) a cypress swamp of saturated peaty and organic silty and clayey soils.
5. Dike material. Borrow areas were located within the containment area. Poor surface material was stripped to obtain sand, clayey sand, and some fragmented limestone.
6. Cross section. Major portion of dike: height, 20 to 25 ft; crown width, 15 ft; slopes, 1V on 2H. Swamp crossing: height, 40 ft; crown width, 15 ft; slopes, 1V on 2.5H.
7. Construction. Foundation was cleared and grubbed. Removal of as much as 10 to 15 ft of dredged material and swamp deposits of peaty organic silty and clayey material and any buried logs, stumps, and roots was required along some portions of the dike. In all areas, stripping of sod and accumulated surficial vegetative matter was performed. A temporary wellpoint system was used to dewater the foundation during embankment construction at the swamp crossing. The dewatering system was not entirely successful. Embankment fill was placed in horizontal layers (8 to 12 in. thick) and compacted primarily by routing of scrapers. During construction, the contractor was required to conduct various tests to insure construction quality. Tests included moisture content, in-place density, modified compaction, mechanical analyses, Atterberg limits, and specific gravity. The embankment was seeded immediately following construction.
8. Design investigations. Field: disturbed and undisturbed sample borings; split-spoon penetration resistance tests. Laboratory: visual classification and water content determinations; precise classification of representative samples; Q- and R-tests of undisturbed foundation samples; direct shear and R-tests of compacted specimens of borrow materials; permeability tests on some compacted specimens (borrow materials) using either clean water or a simulated dredge slurry of 4 parts sea water to 1 part silt. Stability analyses (circular arc and wedge methods) were conducted for end of construction and steady seepage cases. Computed minimum factors of safety were generally near 1.1. Embankment shear strength was based on R-tests of compacted specimens of borrow materials. Foundation shear strengths were based on the Q- and R-tests of undisturbed foundation specimens.
9. Special features. This is the first of three diked containment areas to be located close to each other. If necessary to meet water quality requirements, this area was designed to contain 16,000,000 cu yd of dredge slurry (without decanting) deposited during the first seven maintenance operations.

DIKE DESCRIPTION C-7

1. Dike involved. Interior dike at the Craney Island containment facility, Norfolk District.
2. Design responsibility. CE.
3. Construction responsibility. Equipment and operating personnel leased by CE.
4. Foundation. Dredged material consisting of silt and sand with a variable organic content. Water table at about 4 ft below surface.
5. Dike material. Dredged material from within disposal area.
6. Cross section. Height, 6 to 8 ft; crown width, 3 ft; slopes, 1V on 1H.
7. Construction. Fill was placed by dragline with no compaction.
8. Comment. The alignment of this dike was located within the original dike and a previously constructed interior dike.

DIKE DESCRIPTION C-8

1. Dike involved. Interior dike at the Grassy Island containment facility, Detroit District.
2. Design responsibility. CE.
3. Construction responsibility. Private contractor.
4. Foundation. Dredged material consisting of organic silts and clays and sandy silts.
5. Dike material. Predominantly clay with some sand and gravel from a nearby borrow area located outside the disposal area.
6. Cross section. Height, 15 to 18 ft; crown width, 25 ft; slopes, 1V on 2H.
7. Construction. Fill was placed in 12-in.-thick layers. Compaction was attained with routing of such construction equipment as crawler tractors. In-place density was periodically checked by CE personnel.
8. Design investigations. Field: disturbed and undisturbed sample borings; split-spoon penetration tests. Laboratory: visual classification and water content determinations; precise classification of representative samples; triaxial shear tests (Q-tests) of undisturbed foundation samples. Stability analyses (circular arc and wedge) were conducted for the end of construction case. A minimum factor of safety of 1.25 was computed. Foundation shear strength was based on results of Q-tests on undisturbed foundation specimens. Embankment shear strength was estimated.
9. Comment. This dike was constructed at a considerable distance inward (toward center of disposal area) from the original dike, which is now submerged.

DIKE DESCRIPTION C-9

1. Dike involved. Retaining dike for a containment facility in the Sacramento District.
2. Design responsibility. CE.
3. Construction responsibility. Private contractor.
4. Foundation. Sand.
5. Dike material. Silts, clays, and sands.
6. Cross section. Height, 10 to 15 ft; crown width, 12 ft; slopes, 1V on 2H.
7. Construction. Foundation was cleared and grubbed, and the top 1 ft was stripped. A semicompacted fill was constructed. Fill was placed at its natural moisture content in 6- to 12-in.-thick layers and compacted with specialized tamping rollers. If the contracting officer considered the natural material content of the borrow material to be unsuitable for compaction, the material was wetted or dried as necessary.
8. Comment. In this area, similar dikes are often tied into existing flood control levees to form containment areas.

DIKE DESCRIPTION C-10

1. Dikes involved. Retaining dikes for a containment facility at Blakely Island, Mobile District.
2. Design Responsibility. CE.
3. Construction responsibility. Rental of construction equipment with operators.
4. Foundation. Peats, organic silts, and clay.
5. Dike material. Primarily sand obtained from a previous new-work dredging project.
6. Cross section. (See fig. 35 of main text.)
7. Construction. Soft foundation deposits had to be displaced to establish a firm foundation or base section for the dike. End-dumped sand fill was pushed into the foundation by bulldozer. A 16-ft thickness of soft foundation soils was displaced. During construction, a wave of displaced foundation material (mud wave) formed at the head and sides of the advancing fill. After the base section was established, the embankment was constructed by end-dumping the sand with some compaction achieved by truck traffic on the fill. Slopes were seeded immediately following construction.
8. Design investigations. Field: disturbed and undisturbed sample borings; split-spoon penetration resistance tests. Laboratory: visual classification and water content determinations; precise classification of representative samples; triaxial shear tests (Q-tests) of undisturbed foundation samples.
9. Special features. Prior to the first disposal operations, the dredge contractor was required to place 6-mil polyethylene sheeting on the interior slopes. Adjacent sheets were overlapped 2 to 3 ft and were anchored with sand bags. The sheeting proved to be a poor impermeable barrier. The sheets tore easily during placement and were damaged by rodents. The polyethylene sheeting was successful in preventing erosion due to wave action and wind blowing of sand from the slopes.
10. Failures. There were no major failures; however, during disposal operations, seepage through the dike caused extensive sloughing of the exterior slope along a 50-ft length of dike. Seepage also exited beyond the dike's exterior toe at that same location. Sand bags were placed in voids left by sloughages.
11. Comment. This containment facility is located near a state highway.

APPENDIX D: IN-WATER EARTH- AND ROCK-FILL DIKES DESIGNED BY
THE CE AND CONSTRUCTED UNDER SEPARATE CONTRACTS

DIKE DESCRIPTION D-1

1. Dikes involved. Retaining dikes for two adjacent containment facilities in Sabine Lake, Galveston District.¹¹
2. Design responsibility. CE.
3. Construction responsibility. Private contractor.
4. Foundation. Soft clays and sandy clays overlying a stiff clay. Average depth of water along the dike alignment is 5 ft.
5. Dike material. Stiff clays obtained from within the containment area from a designated borrow area (fig. 24 of the main text); slope protection required as shown in fig. 24.
6. Cross section. (See fig. 24.)
7. Construction. Fill was placed primarily by barge-mounted draglines followed by shaping and compaction by bulldozer. A portion of the dike was constructed by hydraulic fill with final shaping by draglines and bulldozers. Riprap was placed by clamshell.
8. Design investigations. Field: disturbed and undisturbed sample borings; split-spoon penetration resistance tests. Laboratory: visual classification and water content determinations; precise classification of representative samples; triaxial shear tests (Q-test) and unconfined compression tests of undisturbed foundation samples; quality of potential riprap from various sources determined from measurements of properties such as soundness, abrasive resistance, unit weight, and absorption. Stability analyses for the end of construction case were conducted for various locations along the dike alignment. Embankment shear strength was estimated for use in the analyses. Foundation shear strength was determined from results of Q-tests of undisturbed foundation samples. Minimum safety factors computed using the circular arc and wedge analyses were greater than 1.2, except for one location where a value of 1.1 was determined. Slope protection was designed using methods contained in "Shore Protection/Planning and Design," U. S. Army Coastal Engineering Research Center, Technical Report No. 4, third edition, 1966.³⁴
9. Failures. Within a few months after construction, wave action eroded the unprotected interior slope and reduced the crown width by one-half. New-work dredged material was pumped along the damaged section and produced a crown width of 29 to 30 ft and flat slope to dissipate wave energy. An attempt is made to maintain dikes by making necessary repairs during each dredging operation.

DIKE DESCRIPTION D-2

1. Dike involved. Retaining dike for a containment facility at Daniel Island, Charleston District.²⁵
2. Design responsibility. CE.
3. Construction responsibility. Private contractor.
4. Foundation. Soft organic clay, silty sand with shells, sandy clay. Approximately 75 percent of the dike's length was constructed in water with a mean low depth of 8 ft.
5. Dike material. The dike is composed primarily of marl obtained from a nearby river. The marl is a calcareous clay with sand. Previous experience with hydraulically pumped marl had shown that the material discharges in the form of lumps from the size of marbles to basketballs with enough fines and sands to fill voids, thus forming a dense embankment. Slope protection details are shown in fig. 25 of the main text.
6. Cross section. (See fig. 25.)
7. Construction. Fill was hydraulically pumped to a height of 5 ft above the water surface. A barge-mounted dragline then reworked the material to a height of 12 ft above the water surface. Riprap was placed by clamshell.
8. Design investigations. Field: disturbed sample borings; split-spoon penetration resistance tests. Laboratory: visual classification and water content determinations; precise classification of representative samples; model studies to determine current effects and construction schedule. Stability was analyzed for the end of construction case using the circular arc and wedge methods. Foundation shear strength was estimated from split-spoon penetration resistance tests. The embankment shear strength was estimated based on experience with similarly constructed channel contraction dikes. The minimum factor of safety was computed to be about 1.0. This value was acceptable since other dikes constructed in the area with hydraulically placed marl had performed satisfactorily.
9. Comment. These dikes have since been raised through incremental construction.

DIKE DESCRIPTION D-3

1. Dikes involved. Retaining dike for the Craney Island containment facility, Norfolk District.^{14,26}
2. Design responsibility. CE.
3. Construction responsibility. Private contractor.
4. Foundation. Fine sand underlain by weak marine clays. The average depth of water along the dike alignment is 10 ft.
5. Dike material. Sand was obtained from within and adjacent to the disposal area. Details of slope protection are shown in fig. 26 of the main text.
6. Cross section. (See fig. 26.)
7. Construction. Hydraulically pumped sand was topped with a central section constructed by clamshell. On several occasions, the hydraulic fill generated mud waves caused by displacement of the underlying weak clays. The mud waves rose ahead of construction and had to be removed before construction could continue. The mud wave problem was solved by spreading the fill more evenly with a floating-swing discharge line. Clamshell excavation for construction of the central section of the dike produced trenches in the hydraulic fill which were located about 50 ft apart. The trenches were filled with stone to serve as the toe of the riprap protection. Riprap was placed by orange peel.
8. Design investigations. Field: disturbed and undisturbed sample borings. Laboratory: visual classification and water content determinations; precise classification of representative samples; undisturbed foundation samples were subjected to Q- and R-tests, direct shear tests, unconfined compression tests, and consolidation tests. Stability analyses were conducted for the end of construction case using primarily circular arc analyses. Shear strength of the soft clay foundation was based on results of Q-tests of undisturbed samples. Shear strength of the hydraulic fill was estimated from table 7 in reference 32, which gives a representative value of shear strength for loose, dry, uniform round-grain sand. Since the hydraulic fill was saturated, a value slightly less than that given in table 7 was used in the stability analyses. The minimum factor of safety computed from the circular arc analyses was approximately 1.9. From the consolidation test results, it was estimated that 7 to 9 ft of settlement at the dike center line would occur, with half of that amount occurring during the first 15 years. One portion of the dike has settled about 7 ft since its construction in 1954.
9. Failures. Storms: waves breaking over the roadway have scoured stones from the inner slope causing large segments of the roadway to be washed out. Interior wave action has also caused some erosion to inner slopes. Interior slope problems diminished as dredged material elevation increased. Settlement: a portion of the dike is still subsiding (over 7 ft since 1954), and the roadway dips in that area and is in need of repairs, which have been performed a number of times in the past.
10. Comment. Additional dikes have been constructed inside the main dike since the original construction in 1954. The area as it exists today is very poorly drained. A water table exists at about 3 to 4 ft below the surface of the contained dredged material.

DIKE DESCRIPTION D-4

1. Dikes involved. Retaining dikes for two containment facilities in Cleveland Harbor (Areas 1 and 2), Buffalo District.
2. Design responsibility. CE.
3. Construction responsibility. Private contractor.
4. Foundation. Soft clays. The mean low water depth along portions of the dikes is 25 ft.
5. Dike material. (See fig. 29 of the main text.)
6. Cross section. (See fig. 29.)
7. Construction. Dike foundation was stripped of soft bottom sediments. Rock fill for the dike core was dumped from barges by a conveyor-type unloader. Slopes were shaped by clamshell. Riprap was placed by clamshell.
8. Design investigations. Field: disturbed sample borings; split-spoon penetration resistance tests; in situ vane shear tests. Laboratory: visual classification and water content determinations; precise classification of representative samples. Stability analyses were conducted for the end of construction case using the wedge and circular arc methods. Embankment shear strengths were estimated and foundation shear strengths were determined from results of in situ vane shear tests. The minimum factor of safety was 1.2.

DIKE DESCRIPTION D-5

1. Dike involved. Retaining dike for containment facility in Buffalo Harbor (Area 1), Buffalo District.
2. Design responsibility. CE.
3. Construction responsibility. Private contractor.
4. Foundation. Soft clays. Low water depth is 10 ft along the major portion of the dike alignment.
5. Dike material. (See fig. 30 of the main text.)
6. Cross section. (See fig. 30.)
7. Construction. Dike foundation was stripped of soft bottom sediments. Fill was end-dumped from haul trucks. Construction began adjacent to shore and progressed outward as a haul road was established. Slopes were shaped by clamshell. Riprap was initially placed by end-dumping; however, this yielded a segregated cover. End-dumping operations were halted and clamshells were used to continue riprap placement.
8. Design investigations. Field: disturbed sample borings; split-spoon penetration resistance tests; in situ vane shear tests. Laboratory: visual classification and water content determinations; precise classification of representative samples. Stability analyses were conducted for the end of construction case using the wedge and circular arc methods. Embankment shear strengths were estimated and foundation shear strengths were determined from results of in situ vane shear tests. The minimum factor of safety was 1.2.
9. Failures. Storms caused displacement and loss of riprap and interior slope damage (fig. 44). During the repair, additional embankment fill and riprap was placed. Riprap protection was extended across the top and down the inside slope of the dike.

DIKE DESCRIPTION D-6

1. Dike involved. Retaining dike for a containment facility in Buffalo Harbor (Area 2), Buffalo District.
2. Design responsibility. CE.
3. Construction responsibility. Private contractor.
4. Foundation. Soft clays. Low water depth is 10 ft along the major portion of the dike alignment.
5. Dike material. (See fig. 31 of the main text.)
6. Cross section. (See fig. 31.)
7. Construction. Dike foundation was stripped of soft bottom sediments. Fill was end-dumped from haul trucks. Construction began adjacent to shore and progressed outward as a haul road was established. Slopes were shaped by clamshell. Riprap was placed by clamshell.
8. Design investigations. Field: disturbed sample borings; split-spoon penetration resistance tests; in situ vane shear tests. Laboratory: visual classification and water content determinations; precise classification of representative samples. Stability analyses were conducted for the end of construction case using the wedge and circular arc methods. Embankment shear strengths were estimated and foundation shear strengths were determined from results of in situ vane shear tests. The minimum factor of safety was 1.2.
9. Special features. Because of the storm damage suffered by the dike at Buffalo Harbor, Area 1 (D-5), slope protection was more extensive on the dike at Buffalo Harbor, Area 2. Heavier stone was used and the riprap and spall layers were extended across the crown as shown in fig. 31.

DIKE DESCRIPTION D-7

1. Dike involved. Retaining dike for a portion of a proposed containment facility in Milwaukee Harbor, Chicago District.²⁷
2. Design responsibility. CE.
3. Construction responsibility. Private contractor.
4. Foundation. Medium dense silty sand overlying sandy clay glacial till. Low water depth along the dike alignment is approximately 20 ft.
5. Dike material. (See fig. 27 of main text.)
6. Cross section. (See fig. 27.)
7. Design investigations. Field: disturbed and undisturbed sample boring; split-spoon penetration resistance tests. Laboratory: visual classification and water content determinations; precise classification of representative samples; Q-tests of undisturbed foundation samples; miniature vane shear tests (torvane tests) of undisturbed foundation samples. Stability analyses were conducted for the end of construction case using the wedge method. Embankment shear strength was estimated and foundation shear strengths were determined from results of Q-tests of undisturbed foundation samples. The minimum factor of safety was computed to be 1.5.
8. Comment. The retaining dike is to be comprised of an earth- and rock-fill embankment and an earth-fill cellular steel sheet pile wall (see plan in fig. 17).

DIKE DESCRIPTION D-8

1. Dikes involved. Retaining dikes for a portion of a proposed containment facility in Waukegan Harbor, Chicago District.²⁸
2. Design responsibility. CE.
3. Construction responsibility. Private contractor.
4. Foundation. Clean medium-dense sand overlying a dense silty clay glacial till. Low water depth along the dike alignment is approximately 17 ft.
5. Dike material. (See fig. 28 of the main text.)
6. Cross Section. (See fig. 28.)
7. Design investigations. Only preliminary at this time. Sample borings from adjacent area have been reviewed.
8. Comment. The retaining dike is to be comprised of an earth- and rock-fill embankment and an earth-fill cellular steel sheet pile wall.

DIKE DESCRIPTION D-9

1. Dike involved. Retaining dike for a proposed containment facility in Buffalo Harbor, Buffalo District.²⁹
2. Design responsibility. CE.
3. Construction responsibility. Private contractor.
4. Foundation. Soft clays. Low water depth along the dike alignment is approximately 30 ft.
5. Dike Material. (See fig. 32 of the main text.)
6. Cross section. (See fig. 32.)
7. Comment. An earth-fill has been proposed of steel sheet pile wall.

DOCUMENT CONTROL DATA - R & D

(Security classification of title, body of abstract and indexing annotation must be entered when the overall report is classified)

1. ORIGINATING ACTIVITY (Corporate author) U. S. Army Engineer Waterways Experiment Station Vicksburg, Mississippi		2a. REPORT SECURITY CLASSIFICATION Unclassified	
		2b. GROUP	
3. REPORT TITLE PRACTICES AND PROBLEMS IN THE CONFINEMENT OF DREDGED MATERIAL IN CORPS OF ENGINEERS PROJECTS			
4. DESCRIPTIVE NOTES (Type of report and inclusive dates) Final report			
5. AUTHOR(S) (First name, middle initial, last name) William L. Murphy Timothy W. Zeigler			
6. REPORT DATE May 1974		7a. TOTAL NO. OF PAGES 188	7b. NO. OF REFS 52
8a. CONTRACT OR GRANT NO.		9a. ORIGINATOR'S REPORT NUMBER(S) Technical Report D-74-2	
b. PROJECT NO.			
c.		9b. OTHER REPORT NO(S) (Any other numbers that may be assigned this report)	
d.			
10. DISTRIBUTION STATEMENT Approved for public release; distribution unlimited.			
11. SUPPLEMENTARY NOTES		12. SPONSORING MILITARY ACTIVITY Office of Dredged Material Research U. S. Army Engineer Waterways Experiment Station Vicksburg, Miss.	
13. ABSTRACT Confined dredged material disposal problems and practices were discussed with representatives of 17 Corps of Engineers (CE) District offices to obtain a data base for subsequent related research efforts to be implemented by the Dredged Material Research Program at the U. S. Army Engineer Waterways Experiment Station and to disseminate the data to CE Districts and others. Although confined disposal of dredged material when compared with unconfined disposal is secondary in terms of quantity, it is increasing because of recent requirements for containment of dredged material that is considered polluted and the resulting curtailment of much open water disposal. A diminishing supply of suitable disposal areas, caused by filling of existing sites and difficulties of acquiring sites because of environmental or cultural constraints, has become a major problem of CE Districts. Long-range planning by some CE Districts has suggested three solutions to this problem: (a) long-distance piping of dredged material to large disposal facilities, (b) diking of disposal areas in water, and (c) possible acquisition of permanent disposal facility acreage by the Federal Government. Reuse of filled disposal facilities for agricultural, recreational, and industrial purposes, and for recycling of the dredged material itself is also being investigated by CE Districts and others. Dredged material is most often conveyed to confined disposal facilities hydraulically; that is, by pipeline dredge or by pumpout of hopper dredges, temporary rehandling basins, or loaded scows. Mechanical filling of areas by dipper, bucket, and ladder dredges is less frequent and usually supplementary to hydraulic methods. Long-distance hydraulic pumping of dredged and similar materials has been shown to be feasible both by CE dredging experience and by nondredging industry-related applications. Size limitations on the material pumped, costs of equipment and personnel, and right-of-way acquisition difficulties are problems in the implementation of long-distance slurry transport. There are few efficient, well-designed facilities for the containment of dredged material. Channelization of dredged material from the discharge point to the sluice, the effects of wind, mounding and uneven distribution of dredged material, and retaining dike stability are common problems associated with containment facility operation. Present efforts in abating the above problems and in improving the efficiency of containment facilities consist primarily of the use of energy dissipating devices within the facility and the use of various sluice configurations. The sluices most commonly used are the drop inlet type, but siphons, outfall pipes, flumes, and filters are occasionally used. Odors and mosquitoes are sometimes associated with disposal operations and must be controlled. Effluent quality standards are generally set by the State and are most often density and/or turbidity requirements. At the time of this study, Federal pollution standards regarding effluent quality did not exist.			

14.	KEY WORDS	LINK A		LINK B		LINK C	
		ROLE	WT	ROLE	WT	ROLE	WT
	Dikes Dredged material Dredged spoil Environmental effects Waste disposal sites						

13. ABSTRACT: (Continued)

Guidance in the matter of disposal facility effluent requirements is needed by CE Districts. Retaining dikes are primarily earth embankments constructed on lowland areas or nearshore islands. Several in-water containment facilities have been constructed, and in certain cases rockfill or slag has been used in dike construction. Retaining dike dimensions and composition vary considerably from District to District and within Districts. Dike characteristics are largely dependent on foundation conditions and available construction materials. However, these characteristics are also influenced by individual District policy regarding dike design and construction and available funding. The majority of retaining dikes are constructed as part of the dredging contract, although separate dike construction contracts are used in some instances. In the past, most Districts have left dike design and construction to the discretion of the dredging contractor. However, some Districts have taken a more active role in the control of design and construction because of damaging dike failures and encroachment on populated areas. Little or no information is available on the design of dikes constructed as a part of the dredging contract. CE design of retaining dikes is based primarily on past experiences. Thorough field and laboratory investigations and stability analyses are reserved only for special cases, such as containment facilities planned for long-range disposal and future development or facilities located adjacent to industrialized or populated areas. Dike construction is made difficult by generally poor foundation conditions and the use of low-quality borrow materials. Foundations of soft organic deposits are common. Dike fill is commonly placed loose by dragline with no compaction and often consists of previously deposited fine-grained dredged material with high water content. Hydraulic pumping of materials has been used to establish wide dike sections for support on weak foundations. Semicompaction and stage construction of embankment fills and foundation displacement techniques have been applied to retaining dike construction. Retaining dikes often require continual maintenance. Failures have occurred largely because of poor foundation conditions and construction materials compounded by inadequate dike design, poor construction practices, and minimal inspection of dikes during dredging operations. The effects of seepage are directly responsible for or contribute to the majority of retaining dike failures.

In accordance with ER 70-2-3, paragraph 6c(1)(b), dated 15 February 1973, a facsimile catalog card in Library of Congress format is reproduced below.

Murphy, William L

Practices and problems in the confinement of dredged material in Corps of Engineers projects, by W. L. Murphy and T. W. Zeigler. Vicksburg, U. S. Army Engineer Waterways Experiment Station, 1974.

1 v. (various pagings) illus. 27 cm. (U. S. Waterways Experiment Station. Technical report D-74-2)

Sponsored by Office of Dredged Material Research.
Includes bibliography.

1. Dikes. 2. Dredged material. 3. Dredged spoil.
4. Environmental effects. 5. Waste disposal sites.
I. Zeigler, Timothy W., joint author. (Series: U. S. Waterways Experiment Station, Vicksburg, Miss. Technical report D-74-2)
TA7.W34 no.D-74-2



U. S. ARMY ENGINEER DISTRICT, LOUISVILLE
TECHNICAL LIBRARY
P. O. BOX 59
LOUISVILLE, KENTUCKY 40201

