



**US Army Corps  
of Engineers**

The Hydrologic  
Engineering Center

---

# **Hydrologic Engineering in Planning**

**Training Document No. 14**

**April 1981**

Approved for Public Release. Distribution Unlimited.

## PREFACE

This manual, "Hydrologic Engineering in Planning", grew out of the need in the Corps of Engineers Planning Associates Program for instructive material which presents the basic purpose, concepts and methodologies of hydrologic engineering. While professionals engaged in planning are often educated in a specific technical discipline, such as a branch of civil engineering or economics, the members of a planning team should be able to understand and incorporate the results of the other disciplines (hydrology, hydraulics, economics, engineering design, etc.). This basic understanding contributes toward shared development of innovation and integrated planning solutions that are more responsive to human needs. The intent of this manual is to provide this understanding in the technical area of hydrologic engineering. A secondary purpose of the manual is to organize the material in such a way that a person with hydrologic engineering education and experience who is teaching in the Planning Associates Program can use the manual as a basis for instruction.

The content of this manual varies in level of detail from broad general concepts to detailed technical analysis. Both are needed for a clear understanding of the subject. Concepts are presented to convey the overall meaning and general principles. Detailed analysis are presented where it is essential to a good understanding of the subject. Every effort was made to avoid unnecessary technical detail.

The manual is organized into five sections. There are three main sections: Hydrograph Analysis, Fluvial Hydraulics, and Frequency Analysis. These are, in the opinions of the authors, the three most important areas of hydrologic engineering that should be understood by those engaged in the Corps' water resources planning activities. There are many other aspects which are not covered, and which in any particular instance may be important, but in the majority of planning studies these three seem to be dominant. There are also two other sections which cover subjects which do not fit under the main areas, but are of sufficient importance to be included.

Because each individual may desire more detailed information in a particular subject, most chapters cite important references which provide additional detail. Some of these references are provided with the manual, although the manual is not dependent upon them. Questions and discussions, example problems, and workshop problems are provided to help clarify important material and assist in understanding and interpreting basic computational procedures.

It is the hope of the authors that this manual will meet the need for which it was intended, and that study of the material will provide not only a better understanding of the technical material, but also a greater appreciation of the difficulty of the task of those whose specialty it is.

Mike Burnham,  
Bill Johnson,  
Darryl Davis

CHAPTER

TABLE OF CONTENTS

1	INTRODUCTION TO HYDROLOGIC ENGINEERING
	<u>HYDROGRAPH ANALYSIS</u>
2	INTRODUCTION TO HYDROGRAPH ANALYSIS
3	PRECIPITATION
4	LOSS RATES AND RAINFALL EXCESS
5	HYDROGRAPH ANALYSIS
6	HYDROGRAPH ANALYSIS OF UNGAGED BASINS
7	HYDROGRAPH ANALYSIS OF URBAN AREAS
8	FLOOD ROUTING
9	DESIGN FLOODS
	<u>FLUVIAL HYDRAULICS</u>
10	INTRODUCTION TO FLUVIAL HYDRAULICS
11	STEADY FLOW RIGID BOUNDARY HYDRAULICS
12	WATER SURFACE PROFILE COMPUTATIONS
13	FLOW IN THE VICINTIY OF OBSTACLES
14	UNSTEADY FLOW HYDRAULICS
15	SEDIMENT TRANSPORT IN NATURAL STREAMS
	<u>FREQUENCY ANALYSIS</u>
16	INTRODUCTION TO FREQUENCY ANALYSIS
17	DATA COLLECTION AND EVALUATION
18	DETERMINATION OF FLOW FREQUENCY CURVES
19	FREQUENCIES OF OTHER HYDROLOGIC PHENOMENA
20	RELIABILITY OF FREQUENCY CURVES
21	REGIONAL ANALYSES
22	DEVELOPMENT EFFECTS ON FREQUENCY CURVES
23	USE OF FREQUENCY CURVES IN PLANNING

INTRODUCTION TO  
RESERVOIR YIELD STUDIES

- 24 RESERVOIR YIELD STUDIES
- 25 RESERVOIR SIZING AND OPERATION CONCEPTS

MANAGING HYDROLOGIC STUDIES

- 26 HYDROLOGIC ASPECTS OF PLANNING STUDIES
- 27 HYDROLOGIC ENGINEERING MODELS

REFERENCES

APPENDICES

- A. POINT RAINFALL ATLAS OF THE UNITED STATES
- B. SENSITIVITY ANALYSIS OF FACTORS THAT  
INFLUENCE WATER SURFACE PROFILES
- C. BIBLIOGRAPHY

INTRODUCTION TO HYDROLOGIC ENGINEERING

CHAPTER 1  
INTRODUCTION TO HYDROLOGIC ENGINEERING

Hydrologic Engineering Defined

All water on the earth circulates from atmosphere to surface or subsurface and eventually back to the atmosphere, travelling in a continuous "hydrologic cycle". Hydrology is the study of the waters of the earth, their occurrence, circulation, and distribution, their chemical and physical properties, and their interaction with environment.

Hydrologic engineering, a civil engineering discipline, utilizes hydrologic data such as precipitation, streamflow, and evaporation, in the planning, design, and operation of engineering projects for the control and use of water. Analysis techniques in this field focus on determining the magnitude and frequency of hydrologic events such as storms, flood flows, droughts, and low flows. However, many other aspects of hydrology are important. The major areas of interest in hydrologic engineering are briefly discussed below.

Precipitation-Runoff Processes: Understanding the movement of moisture above, on, and through the surface of the earth is fundamental to water resources management. A sample of the technical aspects of precipitation runoff studies includes:

- o Infiltration Analysis
- o Hydrograph Analysis
- o Streamflow Routing
- o Hydrologic Simulation

Water Resources Systems: Systems of reservoirs are planned, designed, and constructed to serve flood control needs and a variety of water supply purposes. Because of the complex and tedious nature of the analysis, simulation models are often used in these studies. Modeling may be applied to reservoir systems for conservation simulation in order to study low flow augmentation, water supply availability, hydropower production, and water

quality enhancement. When models are applied to reservoir systems for flood control simulation, reservoir levels can be balanced, release priorities determined, and flood damage and benefit data computed. Simulation models may also be utilized in managing systems studies and appraising system performance.

Hydrologic Variability: The variability in long-term runoff and the uncertainty surrounding the magnitude of future flow events necessitates a probabilistic approach toward hydrologic data. Methods of analysis used to determine hydrologic probabilities include:

- o Flood frequency analysis
- o Monthly streamflow simulation
- o Regional frequency analysis
- o Daily streamflow simulation
- o Expected flood risk computation
- o Single and multiple regression analysis
- o System regulated flow relations

Fluvial Hydraulics: In river hydraulics, water surface elevations are related to flow rates as required in flood plain management, flood control, navigation, and other studies. Sediment transport analysis accounts for the changes in channel boundaries over time.

Types of fluvial analyses include computation of:

- o Water surface profiles
- o Scour and deposition
- o Energy loss at bridges
- o Flood plain encroachment
- o Reservoir sedimentation
- o Unsteady flow

Urban Hydrology: The hydrology of urban areas warrants special attention because of the concentration of population. The effects of man-caused and man-induced changes on the quality and quantity of storm



runoff have been justifiably receiving a great deal of national attention in recent years. Urban hydrology may require analysis of the following:

- o Surface and subsurface flow routing
- o Urbanization parameters
- o Pollutant accumulation and washoff functions
- o Storage versus treatment rate and overflow simulation
- o Land surface erosion
- o Dry weather sanitary flows
- o Land use characterization

Water Quality: The need for good quality water to support the requirements of a complex industrial society has long been recognized. Recent environmental awareness has emphasized the intricate relationship between the biological and chemical contents of water and environmental quality. Areas of special emphasis include:

- o Reservoir temperature stratification
- o Impact of wastewater disposal on receiving waters
- o River-reservoir water quality simulation.
- o Monitoring streamflow quality
- o Optimization of operation for quality

Project Operations: As the requirements for operation of water resources systems become more complex, and the consequences of inferior or untimely operation of greater concern, the need grows for accurate hydrologic estimates upon which to base operations. Areas of technical analysis include:

- o Weather forecasting
- o Streamflow forecasting
- o Real-time reservoir operation
- o On-line system control

Groundwater: As possible surface storage sites become fewer and more difficult to develop, storage of water in underground aquifers becomes more attractive. The following areas are currently of concern in groundwater planning and management:

- o Recharge of surface and reclaimed waste waters
- o Conjunctive utilization of surface and groundwater
- o Contamination of groundwater from deep disposal of wastes
- o Overdraft of aquifers
- o Large scale land surface subsidence

### Hydrologic Engineering in Planning

The information generated and analyzed in hydrologic engineering is used in all three major stages of planning: definition of problems, formulation of alternatives, and evaluation of alternatives in terms of project objectives and economic, environmental, and social impacts. Hydrologic investigations such as streamflow frequency analysis, regional correlation studies, ungaged streamflow estimation, and streamflow simulation are useful for developing the basic data needed throughout the planning process. Specific information produced in basic investigations which helps identify problems may include the following:

- o Determination of peak flow rates of historic floods
- o Elevations of 100-year existing conditions flood event
- o 7-day, 10-year low flow (often used as an index for regulatory waste disposal to streams)
- o Dissolved oxygen levels
- o Yield of existing water supply reservoirs

Unit hydrograph and loss rate determinations, hypothetical flood computations, and some types of channel and reservoir routing studies provide input to selection of project features and evaluation criteria. Useful results of such analyses include:

- o Levee elevations necessary to control 100-year flood event
- o Reservoir storage needed to control the standard project flood (SPF)
- o Storage required to collect urban runoff
- o Streamflow needed to maintain minimum quality standards
- o Diversion requirement to supply irrigation demand
- o Channel size necessary to pass selected flood events
- o Change in runoff forecasted with specified future development

Hydrologic simulation such as reservoir operation studies, water surface profile determinations, and flood hydrograph routing and combining are used to evaluate the effects of hydrologic variations on alternative plans and possible impacts on economic, environmental, and social factors.

Examples of useful information generated in such simulations are:

- o The degree of flood protection provided at each control point by an alternative mix of facilities
- o The future critical dissolved oxygen level for planned treatment rates at specific locations
- o Expected number of supply shortages for given system storage and demand
- o Annual energy generated by stated installed capacity and storage
- o Number of structures inundated by SPF with alternative proposals

Because hydrologic data can be used in all stages of planning, hydrologic engineering analysis should be considered an integral part of such studies. Economic and environmental analyses should also be incorporated and not conducted independently of the planning process. Multi-disciplinary planning is required now more than ever because current projects usually must satisfy multiple objectives and are often evaluated by complex methods such as alternative futures.

### Scope of Course

The subject of hydrologic engineering in planning can be taught from two viewpoints: 1) given certain functional planning activities, provide instruction on appropriate hydrologic analysis; or 2) provide basic instruction in principles of hydrologic engineering and relate these to planning. Because it is conceptually cleaner to present a technical subject in a systematic fashion and also because many hydrologic engineering subjects have application in a number of functional planning areas, the latter approach has been selected. The major technical areas of hydrograph analysis, frequency analysis, fluvial hydraulics, and reservoir analysis will be presented in the following four sections and their links to planning explained.

HYDROGRAPH ANALYSIS

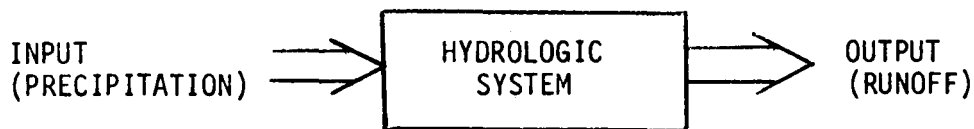
## CHAPTER 2

### INTRODUCTION TO HYDROGRAPH ANALYSIS

#### Components of the Hydrologic System

Water occurs in many places and in many phases on, in, and over the earth. The transformation from one phase to another and the motion from one location to another constitute the hydrologic cycle, which is a closed system having no beginning or end. The hydrologic cycle is illustrated in Figure 2.1.

The hydrologic system may be thought of as encompassing the various processes that govern runoff production in a watershed. The input to the hydrologic system is precipitation, the output is runoff.



The role of the hydrologist is usually to determine runoff at locations of interest in the watershed. Various types of hydrograph analysis may be used to obtain representative runoff values; however, the following components of the hydrologic system must generally be considered:

- o Precipitation - the input for most hydrologic investigations
- o Interception and depression storage - variable depending on the physiography of the system, but remains fairly constant from storm to storm
- o Evapotranspiration - has a small influence from storm to storm but is a main consideration in conservation analysis
- o Infiltration - major variable for flood analysis; changes from storm to storm and with physiography of the system

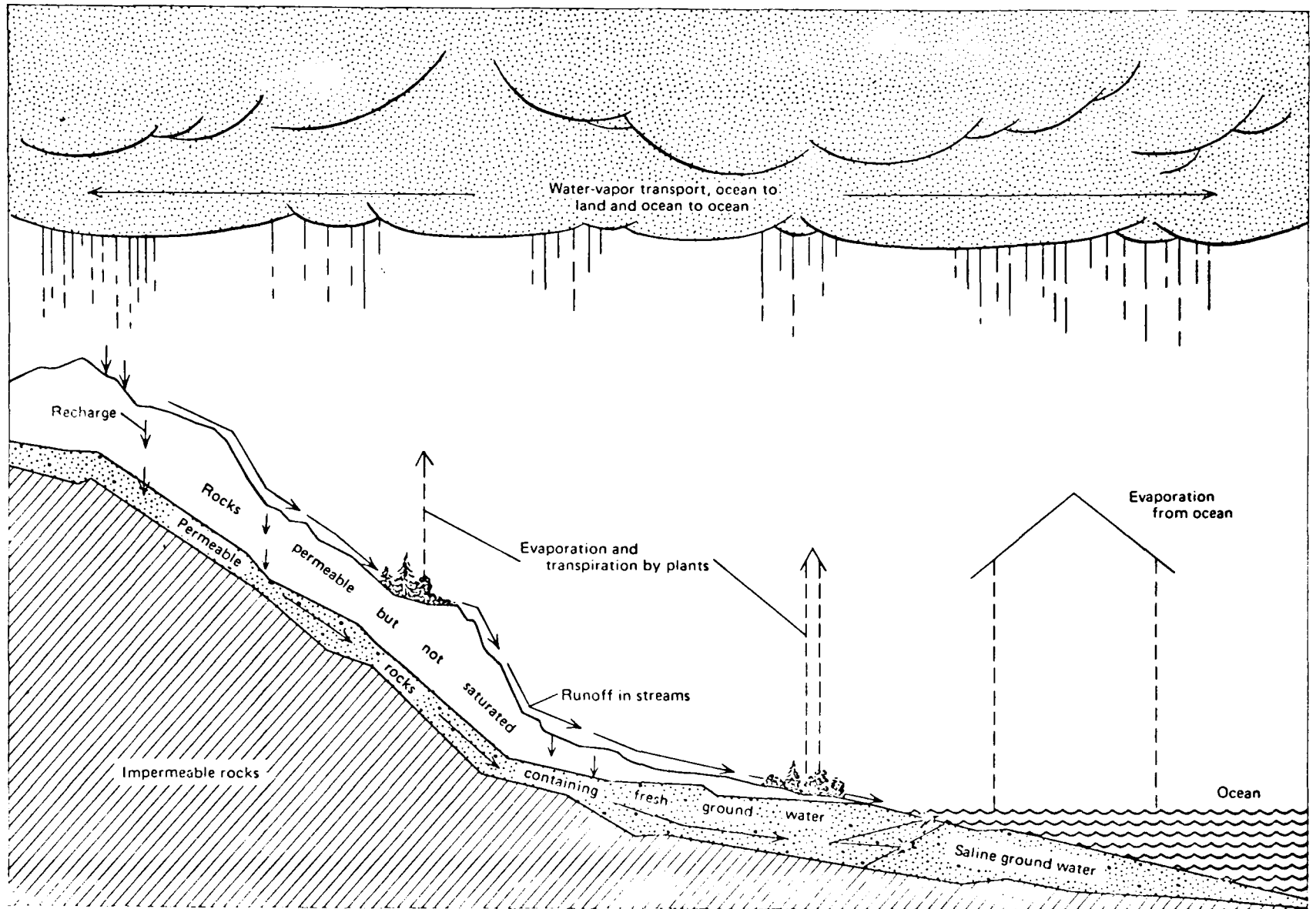


Figure 2.1 HYDROLOGIC CYCLE

- o Surface runoff - of major interest in flood analysis; rates of a given system depend primarily on rainfall intensity
- o Subsurface runoff - of major interest in low flow analysis of conservation studies; rates are variable
- o Groundwater flow - usually a small component of flood analysis, but may be of extreme interest in conservation investigations

### Approaches to Hydrograph Analysis

Several general approaches may be taken to performing hydrograph analysis. One approach may be more applicable than another, depending on the data available and the type of results desired.

Historic Record Analysis: The direct use of historic records (with adjustments as necessary) is considered the most reliable approach to hydrograph analysis. It is most applicable for projects on major river systems where lengthy records are generally available and watershed land use has remained essentially constant or where land use change only involves a small part of the basin. The major analysis efforts are to obtain and adjust the historic records to a common base, and to complete the records which had missing data.

The use of historic records is preferred by many analysts because they believe that events similar to those that have occurred in the past are likely to occur in the future.

Synthetic Event Analysis: The analysis of synthetic events involves calculation of storm runoff from hypothetical or historic storms. "Synthetic" indicates computed rather than measured data. This is considered by many to be a much less reliable method of determining streamflow but is required whenever streamflow records are not available. Such instances are common for small streams and whenever a change in watershed land use or any hydrologic condition significantly affects streamflow. For planning studies in which land use varies, for example when alternative futures are considered, synthetic or hypothetical hydrograph computations must be performed. The development of hydrologic information for very rare floods,

which are likely not to appear in the historic record, such as the standard project and probable maximum floods, also requires synthetic event analysis.

Statistical Analysis: This approach relies upon statistical inference in order to transfer observed hydrologic data to conditions or locations of greater interest. The general method is considered by many to be the least reliable. However, statistically-derived information can be applied to regions where data is scarce or unavailable, thus extending the planning framework much farther than otherwise possible.

### Hydrograph Analysis Procedure

Hydrograph analysis generally follows five basic steps:

- 1) Define storm precipitation
- 2) Determine precipitation excess through abstraction of losses
- 3) Transform precipitation excess to streamflow
- 4) Estimate other contributions in order to obtain the total runoff hydrograph
- 5) Combine and route hydrographs throughout the watershed to obtain hydrograph at locations of interest.

Chapters 3, 4, 5 and 8 discuss the above steps in detail. Chapter 6 covers the techniques used when ungauged basins are analyzed, and Chapter 7 addresses the effects of urbanization on hydrologic conditions and hydrograph characteristics.



## CHAPTER 3 PRECIPITATION

### General Overview

Precipitation is usually considered the input to hydrologic studies. The type of hydrologic studies requiring precipitation data are:

- o Rainfall-runoff analysis
- o Streamflow data extension
- o Water budget determination
- o Water balance in reservoir operation studies

The predominate forms of precipitation are rain, snow and hail and several variations of these forms such as orizzle and sleet. Precipitation is dervied from atmospheric water, its form and quantity are therefore influenced by the action of other climatic factors. Geographic considerations that affect the character and distribution of meteorologic conditions over the surface of the earth are also involved. Factors influencing precipitation are:

- o Climatic
  - wind
  - temperature
  - atmospheric pressure
  - humidity
- o Geographic
  - latitude
  - altitude
  - topography
  - location of land and water surfaces

Hyrologists are interested in the effects of meteorological conditions and the reaction of precipitation after it occurs on the surface of the

earth. Since time variations in precipitation intensity are extremely important in the runoff process, the hydrologist is usually required to obtain and verify as much precipitation information as possible. The areal distribution of precipitation is also important and highly correlated with the time history of the runoff outflow. These considerations are discussed in following sections of this and other chapters.

### Precipitation Measurements

Rain gages: Although a variety of instruments and techniques have been developed to measure precipitation, the hydrologist is primarily interested in data collected from rain gages. There are over 14,500 rain gages in the United States (about one per 230 mi<sup>2</sup>). Of these approximately 3,600 are recording gages which automatically measure the time distribution of storm events. The remaining gages are nonrecording, which are physically observed once each day, usually with volunteer help. Figures 3.1a and 3.1b illustrate rainfall data obtained from nonrecording and recording rain gages, respectively.

Any open receptacle with vertical sides is a convenient rain gage, but because of wind and splash effects the measurements are not comparable unless the receptacles are the same size and shape and similarly exposed. The standard gage of the U.S. National Weather Service has a collector of 8-inches in diameter. Rain passes from the collector into a cylindrical measuring tube where amounts collected may be measured to the nearest 0.01 inch.

Radar: A radar transmits a pulse of electromagnetic energy as a beam in a direction determined by a movable antenna. The radiated wave, which travels at the speed of light, is partially reflected by cloud or precipitation particles and returns to the radar, where it is received by the same antenna. Meteorologists use radar to determine the range and direction of a storm from the radar site. Indications as to the intensity and movement of the storm may also be obtained from radar (See Figure 3.1c).

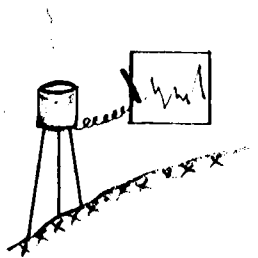
Analysis errors: Precipitation measurements are subject to various errors, most being individually small but with a general tendency to yield

(a.) Nonrecording Rain Gage

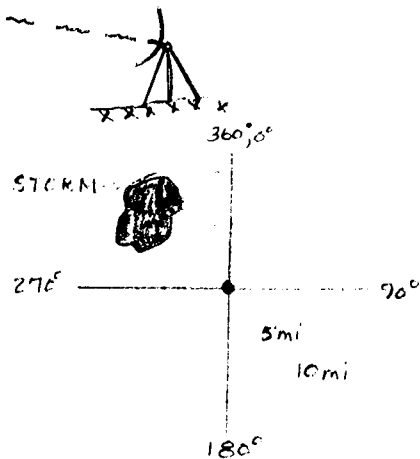


DAILY LOG		
<u>DATE</u>		<u>RAINFALL</u>
1 June 1970		.03
2 June 1970		1.43
3 June 1970		0.00

(b.) Recording Rain Gage



AUTOMATICALLY RECORDED DATA FOR 2 JUNE 1970	
<u>TIME</u>	<u>RAINFALL</u>
0300	.01
0315	.10
0330	.02



(c.) Radar

RADAR DESCRIPTION OF STORM OF 2 JUNE 1970	
Time.....	0315 hrs.
Direction.....	315°
Range.....	10 mi.
Intensity.....	medium
Movement.....	NE
Speed.....	15 m.p.h.

Figure 3.1 PRECIPITATION MEASUREMENT TECHNIQUES

measurements that are too low. The most significant errors in recording rainfall at gage locations are:

- o Wind (probably the most significant, especially in measuring snowfall)
- o Errors in scale reading
- o Gages placed on steep slopes
- o Instrument malfunctions

In precipitation analysis (discussed in the following section) the major errors occur not in precipitation measurements, but in spatially distributing rainfall over a watershed from point rain gage sources.

The availability and use of radar information may help reduce these errors in the future. When considering all the inaccuracies in rainfall measurement and spatial distribution for analysis, more confidence is often placed in rainfall analysis than is warranted.

#### Rainfall Analysis of Historic Storms Over an Area

Most hydrologic studies of historic storm events require knowledge of precipitation over a specific area. Since precipitation information obtained from rain gages represents conditions at a point, techniques are required to transform point precipitation into information representative of the entire area. Three commonly used techniques are: station-average method, Thiessen method, and isohyetal method.

Station-Average Method: The simplest method of obtaining the average rainfall depth is to average arithmetically the gaged amount in the area (See Figure 3.2a). If stations are spaced with reasonable uniformity and the individual gage catches do not vary widely from the mean, the arithmetic average will usually suffice. In most cases, more precise methods are required.

Thiessen Method: The Thiessen method weights each station in direct proportion to the area it represents without consideration of topography or

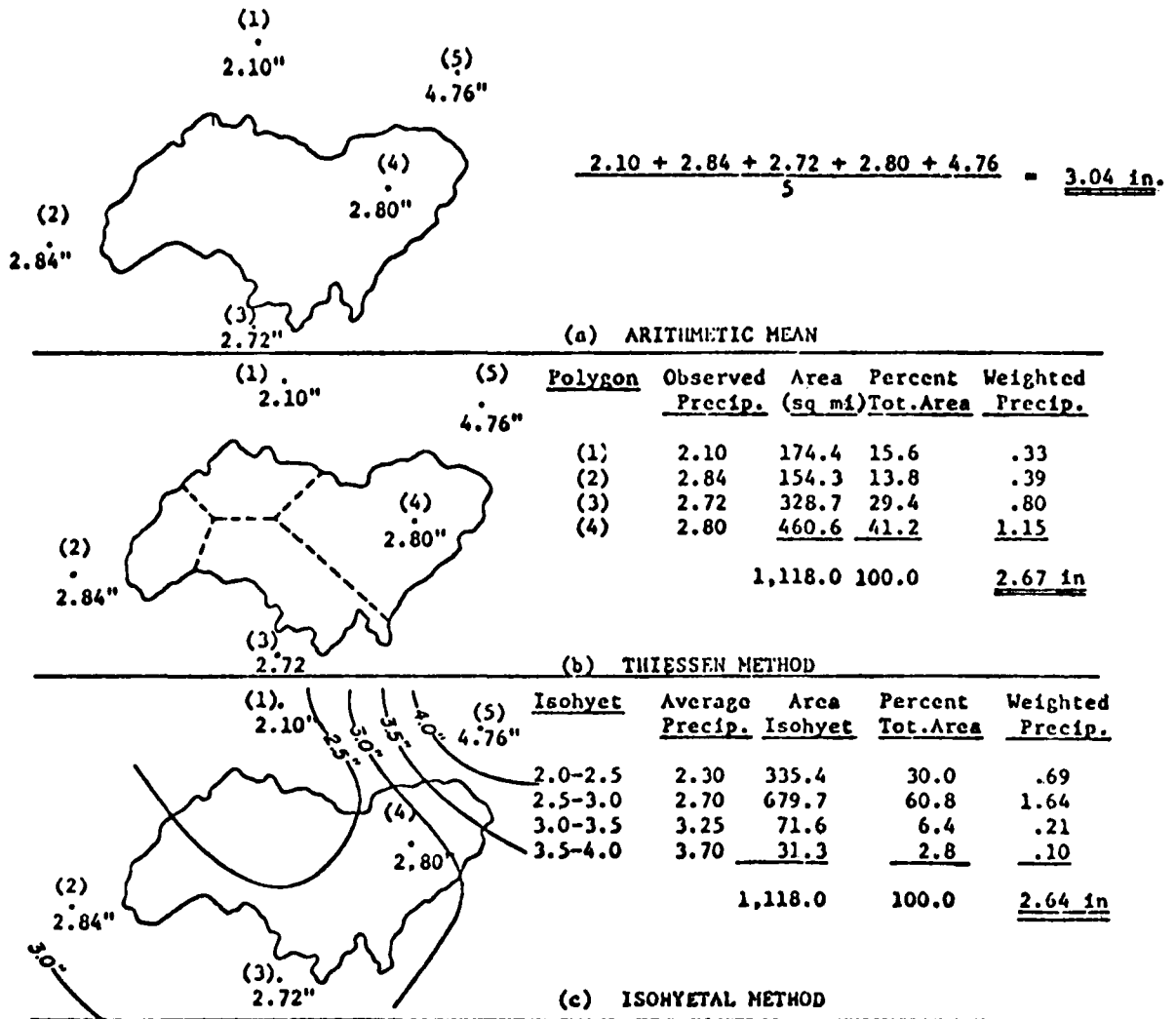


Figure 3.2 BASIN AVERAGE RAINFALL ANALYSIS TECHNIQUES

other characteristics. The area represented by each station is assumed to be that which is closer to it than any other station. The area of influence of each station is obtained by constructing polygons determined by drawing perpendicular bisectors to lines connecting the stations as shown in Figure 3.2b. The bisectors are the boundaries of the effective area for each station. The area enclosed is measured, and weighted average precipitation for the total area is computed by multiplying the precipitation at each station by the proportion of the total area within its polygon and adding the products.

The results are usually considered superior to the station average method because the Thiessen method accounts for nonuniform distribution of stations, and automatically excludes stations which do not influence the computation.

Isohyetal Method: The isohyetal method provides a means of considering orographic or other effects in the computation of average precipitation. A precipitation-depth contour map is determined by plotting station precipitation and constructing lines of equal precipitation called isohyets, as shown in Figure 3.2c. Average depths are obtained by measuring the areas between adjacent isohyets. Each increment of area is multiplied by the estimated average precipitation depth for that area. The separate terms are then added and the sum is divided by the total area to obtain the average depth. The isohyetal method permits the use and interpretation of all available data and is well adapted for display and examination. The accuracy of the isohyetal method is largely dependent upon the skill of the engineer performing the analysis. If linear interpolation between stations is used, the results will be essentially the same as those obtained with the Thiessen method.

### Temporal Distribution of Rainfall

The basin average rainfall for the storm of interest must be temporally distributed for analysis purposes. This is important since the time distribution of rainfall affects the runoff at the outlet. The time interval chosen depends on the size of the watershed and its runoff response

characteristics, as well as the overall study objectives. For small basins, the time interval may be 15 minutes or less, for large basin of hundreds of square miles the distribution interval may be several hours.

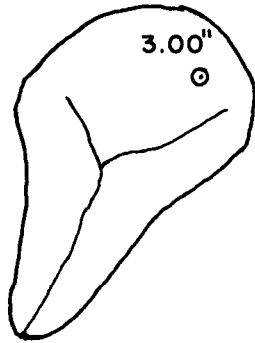
Data from recording rain gages in the proximity of the basin are used to perform the distribution. A simple illustration of the concept involving a recording and two nonrecording stations is shown in Figure 3.3. If more than one recording gage influences the basin, the temporal distributions are usually weighted based on each gage's distance from the centroid of the basin.

### Snow

General: Snow is hydrologically important in many parts of the world. Snowmelt is an important factor in hydrograph analysis in mountainous and high plains basins where the snowpack accumulates throughout the snowfall season and causes flooding during the melt season. Also, the presence of snow can greatly influence the short-term runoff characteristics of a basin under certain conditions of air temperature and rainfall. The evaluation of snowmelt quantities contributing to runoff can be important for:

- o the determination of floods for planning and design purposes
- o operational flood forecasting
- o hydrograph analysis for determining unit hydrograph and loss rate characteristics

Snowfall: Snowfall is that part of precipitation which reaches the ground as ice crystals. If air temperatures near the surface are warmer than those aloft, snow crystals may melt as they descend and occur as rainfall at the surface. In mountainous watersheds, snow may accumulate in the higher elevations while rain occurs at lower elevations. Whether precipitation falls as rain or snow can be estimated from records of air temperatures at the surface, assuming that snowfall occurs wherever surface temperatures are below  $34^{\circ}\text{F}$  to  $36^{\circ}\text{F}$  ( $1^{\circ}\text{C}$  to  $2^{\circ}\text{C}$ ). In mountainous regions, the elevation above which snowfall occurs at any particular time can be determined by applying a lapse rate to surface air temperatures. This is a common practice since most air temperature stations are located in the more accessible, lower elevation areas.



4.00"

Nonrecording Rain Gage ⊙  
Recording Raingage ◆

BASIN AVERAGE RAINFALL WAS  
DETERMINED TO BE 2.60"

⊙  
2.00"

<u>Time in (Hrs)</u>	<u>Recording Gage Values</u>	<u>Percent of Total</u>	<u>Time Distribution of Basin Ave. Rainfall (2.60")*</u>
0700	0	0	0
0800	1.00	25	.65
0900	1.00	25	.65
1000	0.50	12.5	.33
1100	1.00	25	.65
1200	<u>.50</u>	<u>12.5</u>	<u>.32</u>
TOTALS	4.00"	100%	2.60"

\*Developed by multiplying the percent of rainfall occurring at each time period at the recording gage by the basin average values.

Figure 3.3 TIME DISTRIBUTION OF BASIN AVERAGE RAINFALL



Snowpack Measurement: Where spring snowmelt floods are of particular concern, it is usually practical to evaluate the areal extent, water equivalent and depth of the snowpack at specified times before and during the early melt period. The measurements of water equivalent at selected points in the basin and estimates of the areal extent of the snow-covered area are of particular importance. In a manner very similar to the isohyetal analysis of storm rainfall, the amount of water in the snowpack and its areal extent can be mapped. Such mapping must consider elevation and exposure in a mountainous terrain. Where there is appreciable variation of snowpack within the basin, the snowpack water equivalent should be measured at various elevations and exposures. If direct measurement of the snowpack is not made, some approximation of seasonal snow accumulation can be made from rainfall and temperature measurements.

#### Development of Synthetic Storms

Most water resources planning and design studies require hydrologic evaluations where existing historic rainfall data is not sufficient to generate the type or range of runoff hydrographs needed. The hydrologist must therefore rely on the development of synthetic storm events in order to perform a rainfall-runoff analysis. Synthetic storms may be:

- o Frequency events (2-, 10-, 25-, 100-year)
- o Standard Project Storm
- o Probable Maximum Storm

Synthetic storms may be used in hydrologic evaluations of:

- o Frequency analysis of ungaged areas - this includes many hydrologic studies; in particular those pertaining to urban areas and flood plain management
- o Development of specific design floods (discussed in Chapter 9)
- o Provide consistent events for evaluating changes in the hydrologic response of the system - includes evaluation of alternative land use patterns and flood control facilities.

Synthetic Frequency Storms: The U.S. National Weather Service has developed intensity-duration-frequency curves for numerous recording rain gages throughout the United States. An example of an intensity-duration-frequency curve for Chicago, Illinois, is shown in Figure 3.4. To facilitate general use nationwide the Weather Service has published the results of their analysis in the form of a family of maps entitled Technical Paper 40. Excerpts from this publication are shown in Appendix A, Figures A-1 through A-12.

The construction of a synthetic storm of a desired frequency is made using the following procedure:

- o The desired frequency (return period) is determined.
- o Rainfall depth-duration-frequency values at the desired location are obtained from the National Weather Service maps of Technical Paper 40 and plotted as shown in Figure 3.5. Values of accumulated rainfall for 2-hour increments are given to Column 2 of Table 3.1.
- o The accumulated rainfall of Column 2 is not in the sequence in which rainfall is normally accumulated. In order to attain the proper sequence, the incremental rainfall is determined and is shown in Column 3 of Table 3.1. The increments are rearranged in Column 4 to provide a more realistic storm sequence. The most intense portion of the storm is located at the midpoint of the storm, and other increments are rearranged to form an appropriate sequence. The strict arrangement is somewhat arbitrary.
  
- o The rainfall values obtained from Technical Paper 40 are point values, therefore the synthesized storm is for a point in the watershed. This rainfall must be modified if it is to represent the conditions over the total watershed. How large an area is represented by the 8-inch diameter rain gage? The graph in Figure 3.6 is used to translate point rainfall to areal values and adjust the corresponding rainfall values for the watershed size. Column 5 of Table 3.1 has been computed by multiplying the values in Column 4 by the appropriate percentage (0.93) chosen from Figure 3.4 for a drainage area of 100 square miles and a storm duration of 24

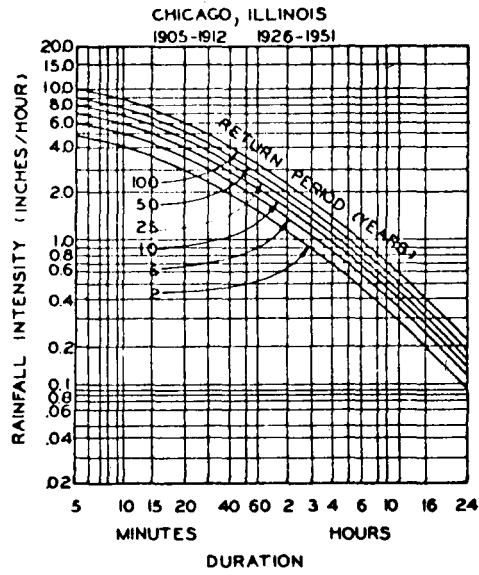


Figure 3.4 INTENSITY-DURATION-FREQUENCY CURVES

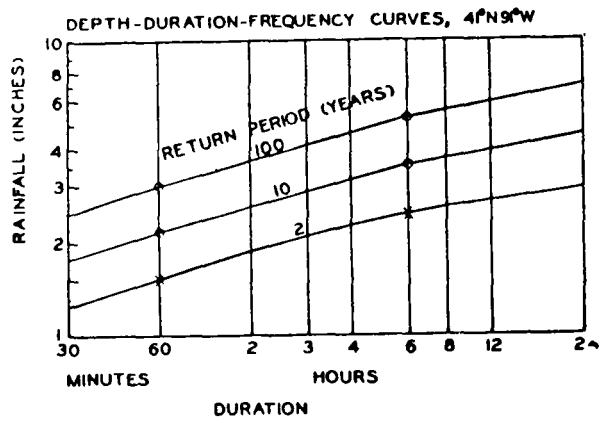
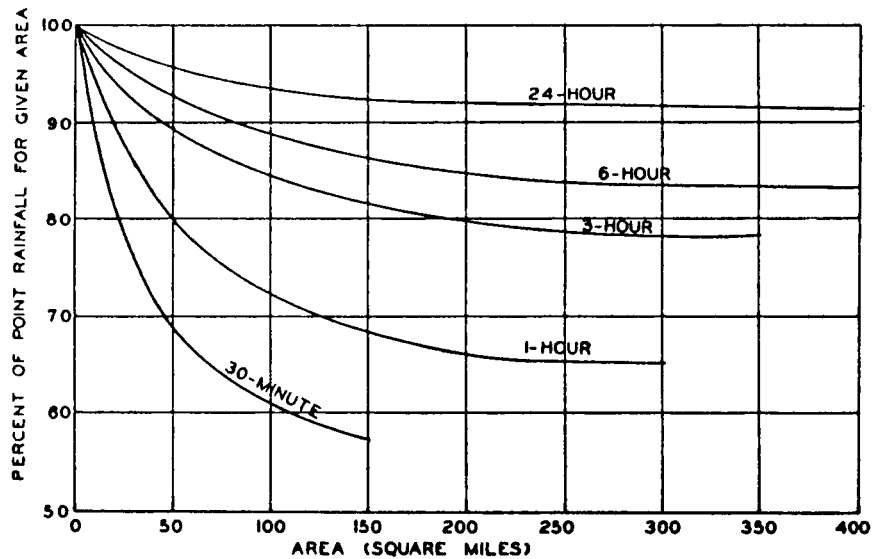


Figure 3.5 INTERPOLATION OF  
DEPTH-DURATION-FREQUENCY VALUES



**Figure 3.6 AREA-DEPTH CURVES FOR USE WITH DURATION-FREQUENCY VALUES**

**Table 3.1 CONSTRUCTION OF A 100-YEAR STORM FOR A 100 SQUARE MILE AREA IN S.E. IOWA**

Time (hrs)	Accumulated rainfall (in.)	Increment (in.)	Rainfall sequence (in.)	Rainfall sequence average over area (in.)
(1)	(2)	(3)	(4)	(5)
0	0		0	
2	3.9	3.9	0.10	0.09
4	4.7	0.8	0.20	0.19
6	5.1	0.4	0.30	0.28
8	5.4	0.3	0.40	0.37
10	5.7	0.3	3.90	3.61
12	5.9	0.2	0.80	0.74
14	6.1	0.2	0.30	0.28
16	6.3	0.2	0.20	0.19
18	6.45	0.15	0.20	0.19
20	6.6	0.15	0.15	0.14
22	6.7	0.10	0.15	0.14
24	6.8	0.10	0.10	0.09

hours. Note that as the storm duration is greater, the point value of rainfall is more nearly equal to the average value.

### Standard Project and Probable Maximum Storms

Two synthetic storms used in many planning and design analyses are the Standard Project and Probable Maximum Storms. These storms are used to develop the Standard Project and Probable Maximum Floods (discussed in Chapter 9). The storms are defined as:

- o Probable Maximum Storm (PMS): The storm resulting from the most severe combination of meteorological conditions that are considered reasonably possible for the area.
- o Standard Project Storm (SPS): Storm that may be expected from the most severe combination of meteorological conditions that are considered reasonably characteristic for the area. Rainfall is usually 40-60 percent of the Probable Maximum rainfall.

Figures A-13 and A-14 illustrate the SPS and PMS 96 hour point rainfall values for areas east of the Rocky Mountains, respectively.

The Standard Project Storm analysis follows a standard procedure that is strictly specified for areas east of the Rocky Mountains and less than 1,000 mi<sup>2</sup> because floods usually result from storms from a general pattern. The procedure is summarized below:

- o Geographic location and area size determine the storm amount
- o Storm totals are adjusted (slightly) for shape
- o Storm total is distributed in strict accordance with a procedure which, in general, distributes 96 hours of rainfall into 4 days specifically arranged, and each day's rain distributed into 4 blocks of 6 hours arrangements. Finally each 6 hour block is specifically distributed to correspond to the desired analysis time interval. Figure 3.7 illustrates the typical temporal distribution of rainfall.

The Probable Maximum Storm is developed using similar procedures to the Standard Project Storm except the initial index rainfall is obtained from Figure A-14.

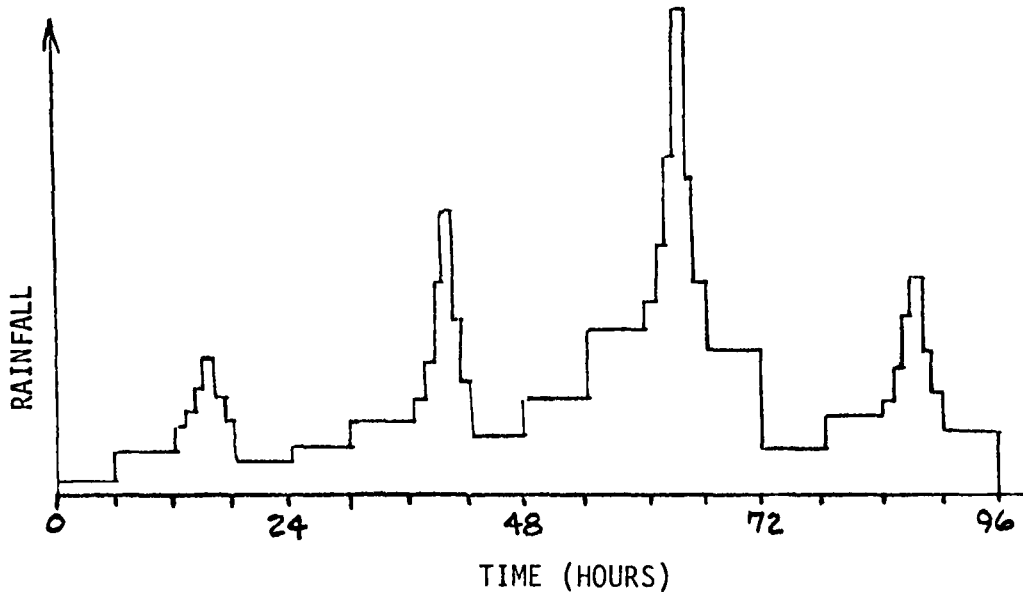


Figure 3.7 96-HOUR STANDARD PROJECT STORM DISTRIBUTION

## CHAPTER 4

### LOSS RATES AND RAINFALL EXCESS

#### General Concepts

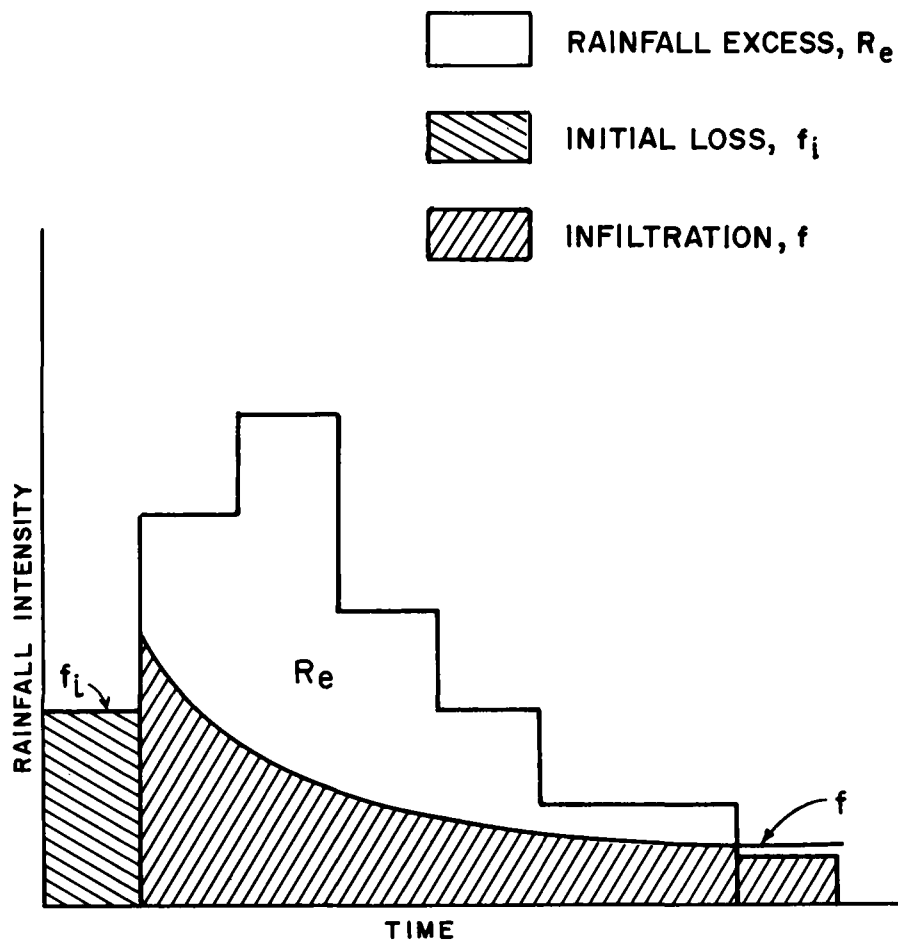
Precipitation is subjected to a number of losses before it eventually appears as flow in a stream. In hydrograph analysis, losses are considered to be the difference between the total amount of precipitation that produced a hydrograph and the volume of water in that hydrograph. Precipitation will be lost by vegetation interception, evaporation, transpiration, and infiltration into the soil. Infiltration is most significant of these processes which divert precipitation from immediate streamflow. Usually more than half of the water which infiltrates is retained in the soil until it is returned to the atmosphere by evapotranspiration. Since infiltration has such a major effect and the other losses are relatively minor, infiltration is ordinarily the only loss that is considered in detail in hydrograph analysis. This simplification will have some effect on the analysis, but considering the inconsistencies and inaccuracies in precipitation and streamflow measurements, the effect is relatively minor. (In conservation studies the losses usually ignored in hydrograph analysis are important and must be considered).

The basic approach to determining loss-rate functions for hydrograph analysis is to develop techniques which approximate actual physical processes and are commensurate with available data. Traditionally, the techniques are based on representing an infiltration capacity curve, such as the typical curve illustrated in Figure 4.1. The infiltration capacity is defined as the maximum rate at which a soil will accept water; it is a function primarily of soil characteristics, land use cover and soil moisture content.

#### Factors Affecting Infiltration and Excess

The major factors affecting infiltration are antecedent moisture conditions, land use cover, and soil types. Soils and land use cover vary spatially over the watershed, whereas antecedent moisture conditions vary from storm to storm. Land use cover may also vary seasonally (vegetal cover) or over a period-of-time (urbanization, etc.).

$$\boxed{\text{RAINFALL}} - \boxed{\text{LOSSES}} = \boxed{\text{RAINFALL EXCESS}}$$



**Figure 4.1 INFILTRATION CAPACITY CURVE**



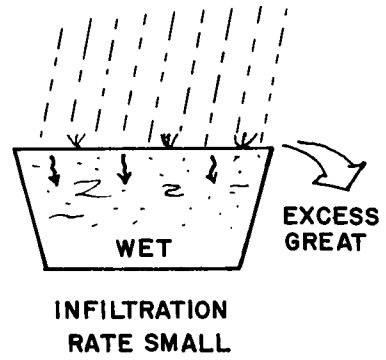
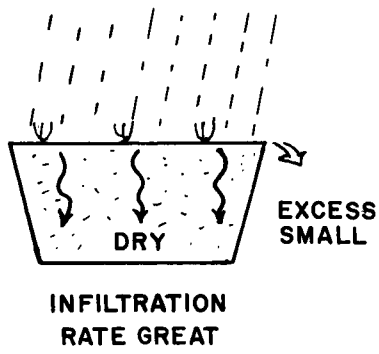
Infiltration is a complex process that is not totally understood, even with today's technology. However, the process may be conceptually simplified by thinking of infiltration as a three step sequence: surface entry, transmission through the soil, and depletion of storage capacity in the soil.

- o Surface Entry - The surface of the soil may be sealed by small soil particles or impervious cover such as parking lots, houses, etc. Soil having excellent underdrainage may be sealed at the surface and thereby have a low infiltration rate.
- o Transmission Rates - Water cannot continue to enter the soil more rapidly than it is transmitted downward. Conditions at the surface cannot increase infiltration unless the transmission capacity of the soil profile is adequate.
- o Storage Capacity in Soils - The storage available in any soil horizon depends on porosity, thickness of the horizon, and the amount of moisture present. The infiltration that occurs in the early part of the storm will largely be controlled by the storage volume in the soil. After the soil is saturated (no storage capacity) the infiltration rate becomes equal to the transmission rate.

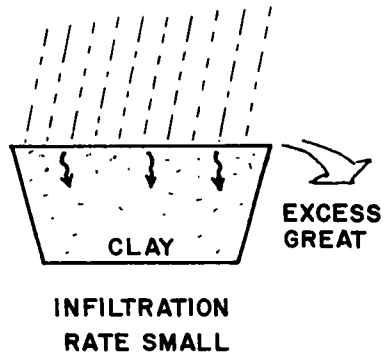
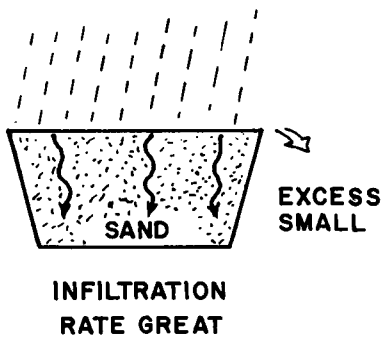
The effects of antecedent moisture, soil type and land use cover on the three steps discussed above is conceptually depicted in Figure 3.2. The buckets represent the storage capacity of the soil which becomes smaller when saturated in Figure 4.2a. In Figure 4.2b, the soil characteristics were changed to demonstrate the transmission variability of different soils, and in Figure 4.2c the surface entry of the soil has been reduced because of urbanization (imperviousness) on the surface.

Initial - Uniform Loss Rates: The most popular infiltration analysis method uses the simple concept of initial and uniform losses. The basic concept is the same as illustrated in Figure 4.1, except the decaying losses are represented by an average or uniform rate. The concepts are similar to those of surface entry, transmission ability and storage capacity and are illustrated in Figure 4.3. The initial losses are the losses that occur prior to the start of runoff (such as depression storage, initial soil

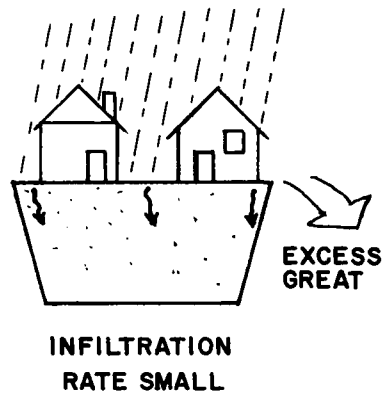
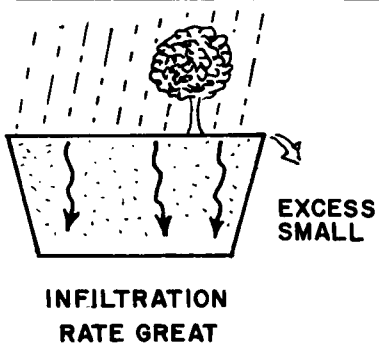
**a. ANTECEDENT MOISTURE CONDITIONS**



**b. SOIL TYPE**



**c. LAND USE COVER (IMPERVIOUSNESS)**



**Figure 4.2 FACTORS THAT AFFECT INFILTRATION RATES**

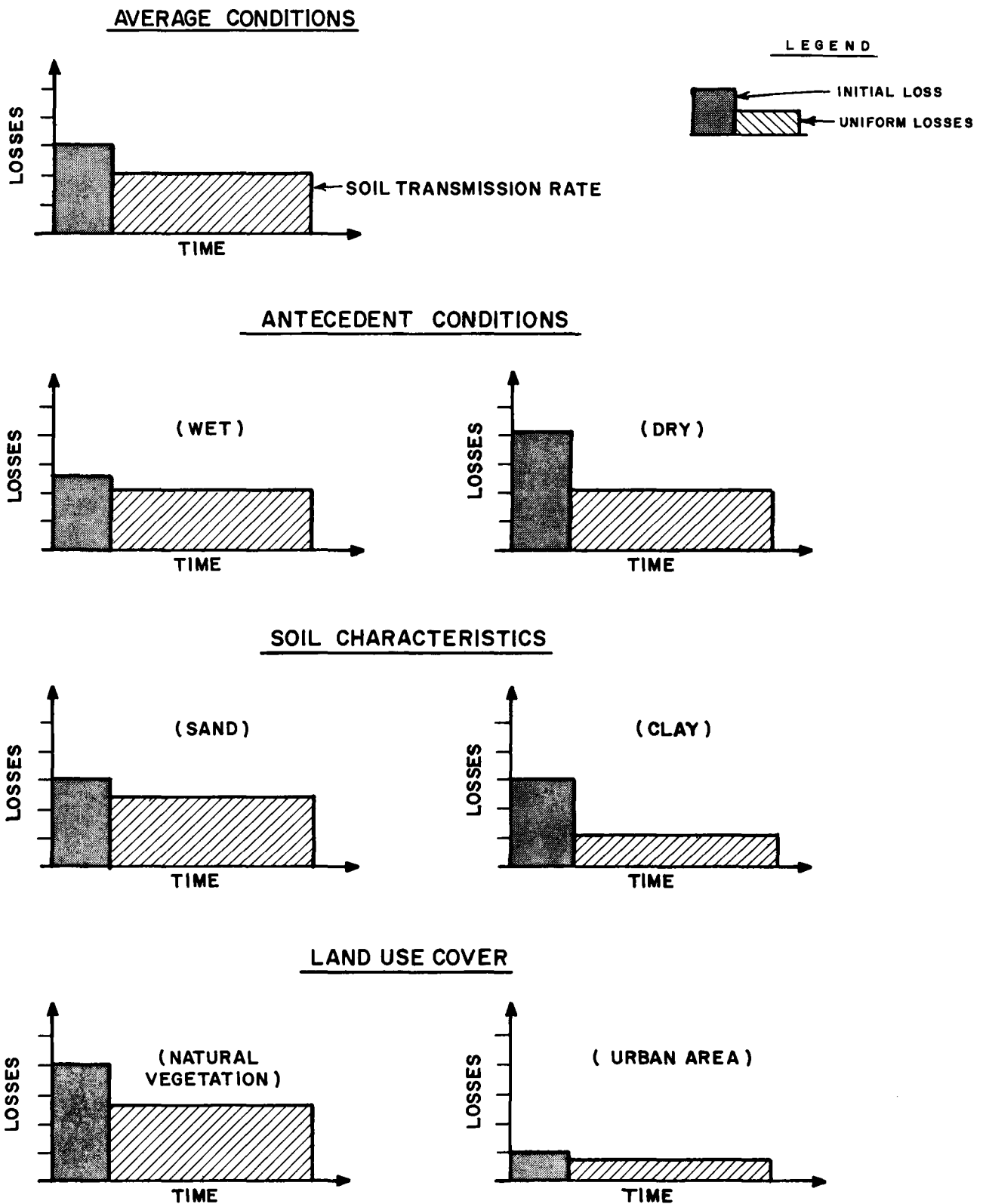


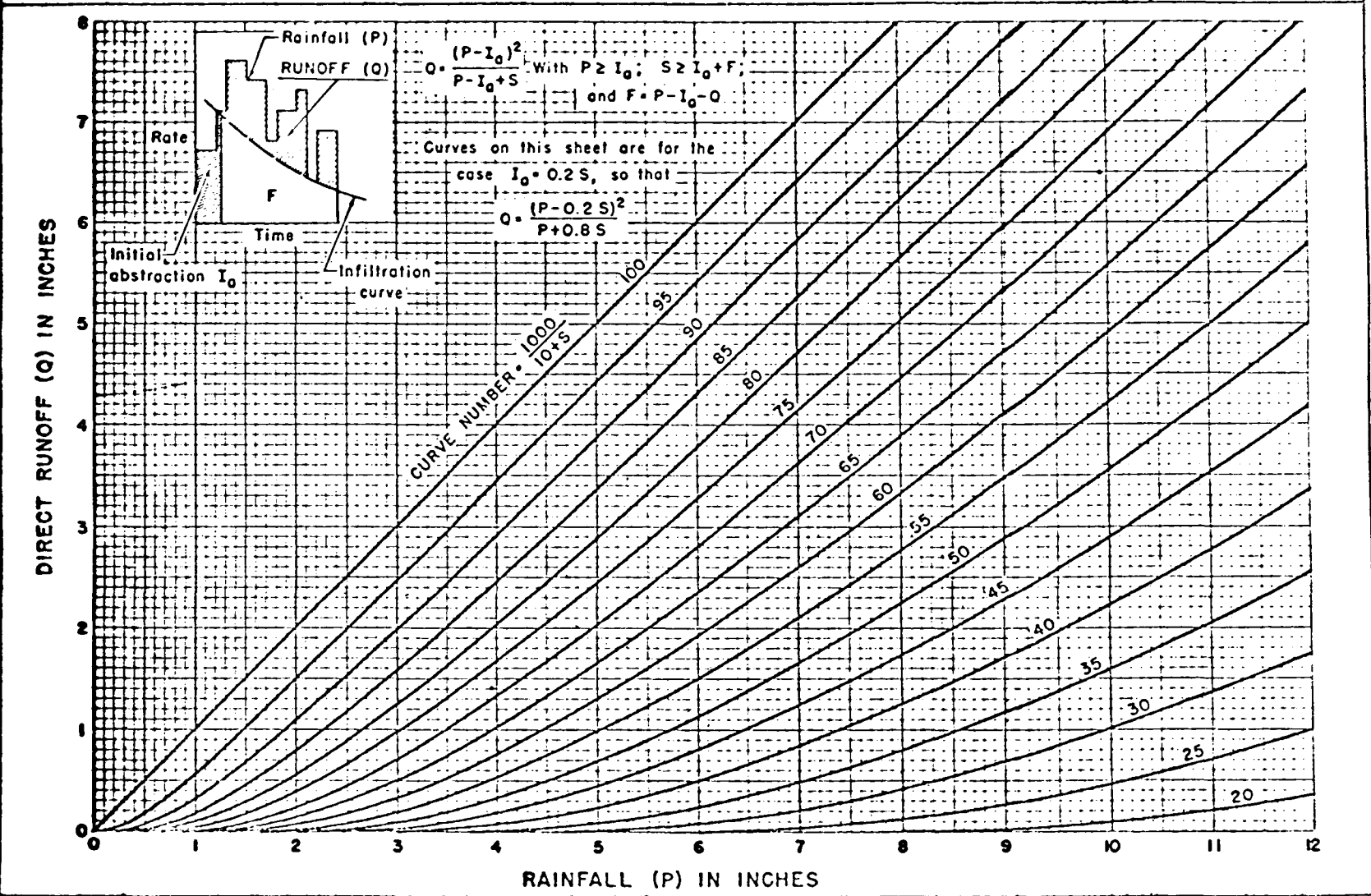
Figure 4.3 INITIAL AND UNIFORM LOSS RATES

abstraction, moisture on leaves, etc.), and are affected by antecedent moisture conditions (Figure 4.3a). The uniform loss rates are the same as the transmission rates and vary primarily with soil type (Figure 4.3b). Land use cover is usually reflected by assuming the amount of imperviousness reduces the surface entry proportionally, i.e., the initial and uniform rates are reduced proportional to the percent of imperviousness of watershed (Figure 4.3c).

Curve Number Technique: The curve number technique of determining infiltration quantities was developed by the U.S. Soil Conservation Service for watersheds for which measurements of rainfall or runoff are unavailable. The curve number is a function of land use, antecedent moisture conditions and soil type. The technique is especially attractive for many hydrologic planning evaluations since it provides a systematic and consistent method of evaluating the effect of alternative land use patterns on the infiltration and excess runoff of a watershed. Figure 4.4 shows the relationship of rainfall and rainfall excess based on various curve numbers.

The general concept is to determine the watershed curve number as a function of soil type and land use, with adjustments made for antecedent moisture conditions if necessary. The watershed soils are divided into four groups based on their hydrologic characteristics. The corresponding land use categories are also determined from tables similar to table 4.1. The watershed average curve number is then computed based on a weighted average of each polygon's area.

**HYDROLOGY: SOLUTION OF RUNOFF EQUATION**  $Q = \frac{(P - 0.2S)^2}{P + 0.8S}$  P = 0 to 12 inches  
Q = 0 to 8 inches



**REFERENCE**  
 Mockus, Victor; Estimating direct runoff amounts from storm rainfall:  
 Central Technical Unit, October 1955

U. S. DEPARTMENT OF AGRICULTURE  
 SOIL CONSERVATION SERVICE  
 WASHINGTON DIVISION - HYDROLOGY BRANCH

STANDARD DRAWING NO.  
 ES-1001  
 SHEET 1 OF 2  
 DATE 8-22-54

REVISED 10-1-64

**Figure 4.4 SCS RAINFALL-RUNOFF SOLUTION**

4.7

TABLE 4.1  
CURVE NUMBER SUMMARY

	Hydrologic Soil Group			
	A	B	C	D
Natural Vegetation	36	60	73	79
Developed Open Space	39	61	74	80
Low Density Residential	47	66	77	81
Medium Density Residential	61	75	83	87
High Density Residential	80	85	90	95
Agricultural	67	78	85	89
Industrial	83	88	92	96
Commercial	95	96	97	98
Pasture	49	69	79	84
Water Bodies	100	100	100	100

where:

Soil Type A - (low runoff potential) Soils which have high infiltration rates - sands and gravels

Soil Type B - Soils having moderate infiltration rates - silts, etc.

Soil Type C - Soils having slow infiltration rates - medium clays

Soil Type D - (high runoff potential) Soils having very low infiltration rates - tight clays

Example Problem

COMPUTATION OF RAINFALL EXCESS

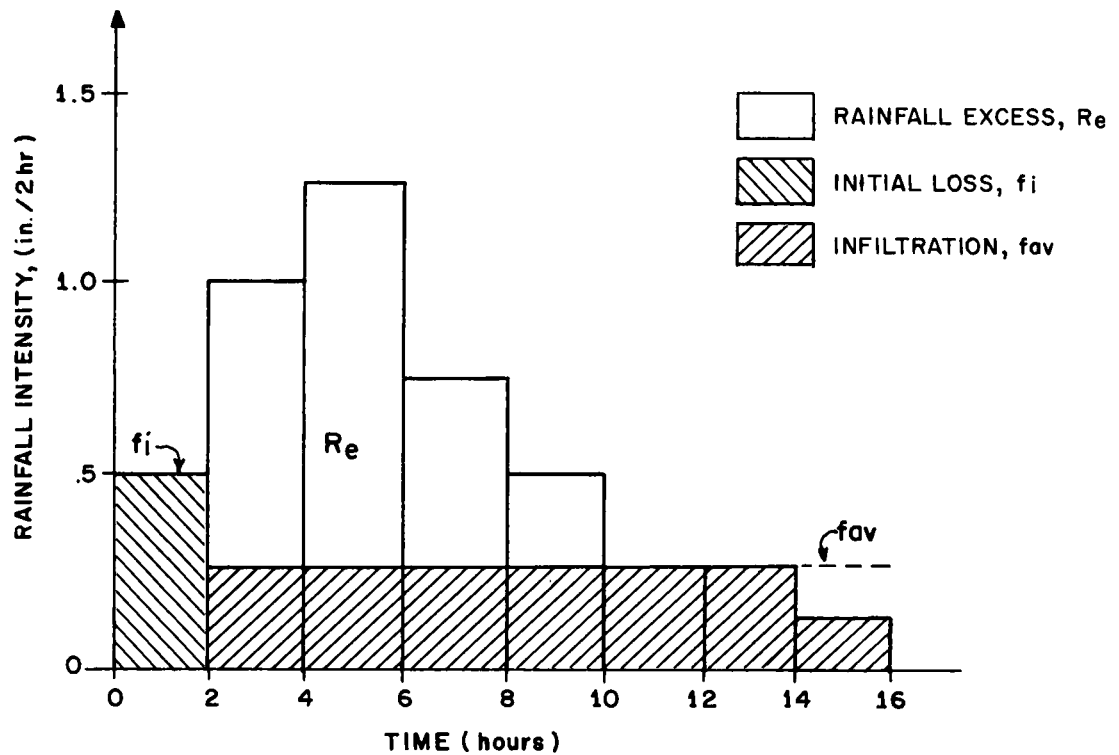
A storm occurred over the Muddy Creek watershed on 2 June 1970 that resulted in minor flood damage along the stream. As part of a flood control study of the watershed, the hydrologist has selected this flood as part of his rainfall-runoff analysis of the basin. He has determined the initial and uniform loss rates to be .50 inches and .25 inches/2-hours, respectively. The basin average rainfall was determined and temporally distributed as shown below. What is the rainfall excess from this storm?

RAINFALL DISTRIBUTION

<u>Time (Hrs.)</u>	<u>Rainfall (Inches)</u>
0	0
2	.50
4	1.00
6	1.25
8	.75
10	.50
12	.25
14	.25
16	.12

INFILTRATION AND EXCESS COMPUTATIONS

TIME (hrs)	RAINFALL (inches)	INITIAL LOSS (inches)	UNIFORM LOSS (inches)	RAINFALL (excess)
0	0	0	0	0
2	.50	.50	0	0
4	1.00		.25	.75
6	1.25		.25	1.00
8	.75		.25	.50
10	.50		.25	.25
12	.25		.25	0
14	.25		.25	0
16	.12		.12	0
TOTAL	4.62	.50	1.62	2.50





QUESTIONS  
CHAPTER 4  
LOSS RATES AND RAINFALL EXCESS

1. Why is infiltration loss usually the only loss considered in hydrograph (flood) analysis studies?
2. What losses are important in conservation studies?
3. What affect does each of the following have on infiltration and rainfall excess?
  - a. Antecedent moisture conditions.
  - b. Land use cover (vegetation, urbanization, pasture, etc.)
  - c. Soil characteristics.
4. What loss rate analysis procedure probably provides the most consistent results when comparing existing and alternative land use patterns?

DISCUSSION OF QUESTIONS  
CHAPTER 4  
LOSS RATES AND RAINFALL EXCESS

1. Infiltration is a major factor affecting direct surface runoff, the primary portion of the flood hydrograph. Other losses are less significant because of the relatively short time span of flood events.
2. In conservation studies the analysis is typically concerned with low flow conditions involving longer time spans and evaluation intervals (weeks, months and in some instances years) than flood analysis. Therefore losses such as transpiration and evaporation become significant in the evaluation process.
3. The effects of antecedent moisture conditions, land use cover, and soil characteristics on infiltration losses and corresponding rainfall excess can be significant.
  - a. Antecedent moisture conditions affect the storage capacity of the soil resulting in greater runoff (rainfall excess) as the soils become saturated.
  - b. Land use cover may enhance or restrict the surface entry of water into the ground. Vegetation may increase infiltration rates whereas urbanization with impervious surfaces would reduce infiltration losses and result in greater runoff.
  - c. Soil characteristics influence the storage capacity and transmission rates of moisture infiltrating into the ground. The coarser sandy soils have less storage capacity but a much higher transmission rate than clay soils.
4. The Soil Conservation Service (SCS) loss rate procedures probably provides the most consistent methodology of comparing existing and alternative land use patterns since they are based on definable characteristics.

## CHAPTER 5

### HYDROGRAPH ANALYSIS

#### Introduction

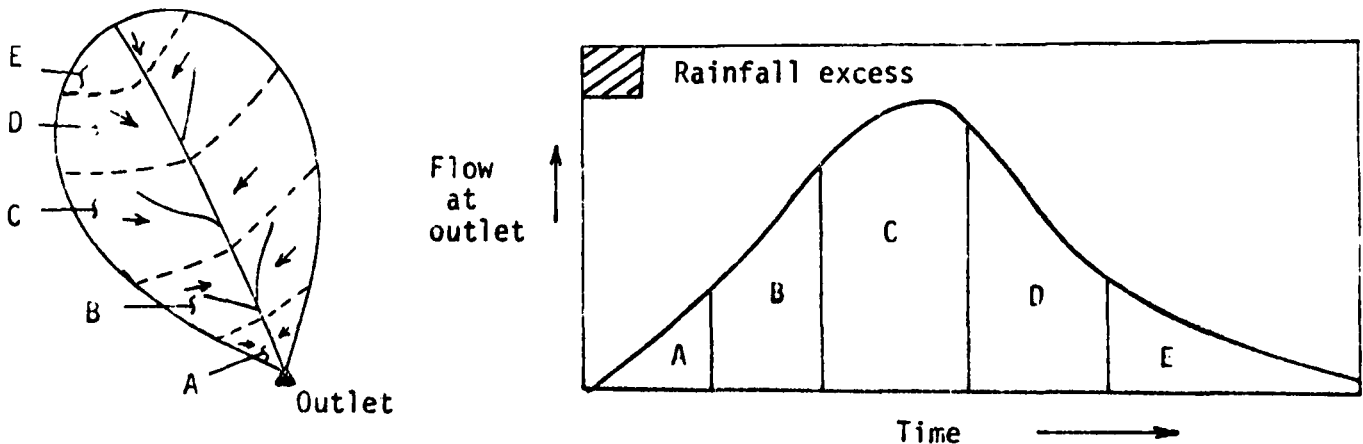
Many water resources studies involving planning, design and operation of watershed systems require estimates of floodflows that result from rainfall or snowmelt events. For most studies historic records of streamflow are nonexistent or not directly applicable to the study objectives. Therefore, analytical techniques such as hydrograph analysis are required to develop floodflows at locations of interest in the watershed system. Typical studies requiring hydrograph analysis evaluations are:

- o Flood plain information studies (Flood Plain Information, Flood Hazard, Flood Insurance Studies) - Provides information on specific flood events such as 10-, 100-, and 500-year frequency floods and possibly the Standard Project Flood event.
- o Alternative future land use patterns - Requires analysis of a specific (say, 100-year event) and/or a range of frequency flood events for existing and future land uses to determine the effects on the flood hazard potential, flood damages, and environmental impacts.
- o Flood loss reduction measures (nonstructural and structural measures) - Requires evaluation of existing and modified conditions for a range of frequency flood events to determine the flood damage reduction associated with specific design flows or in determining the most attractive economic system.
- o Design studies - Specific flood events are used for sizing water resources facilities to assure their safety against failure.
- o Operation studies - Hydrograph analysis techniques may be used to determine if the demands on a facility or system can be met and maintained for specific flood events.

#### General Concepts

Hydrograph analysis techniques involve transforming the rainfall excess that occurs spatially over a basin from a specific storm event into a

corresponding hydrograph at the basin's outlet. A hydrograph is the time distribution of runoff at the outlet of the basin. The volume under the hydrograph is equal to the amount of rainfall excess that occurs over the basin.



The technique used by most Corps hydrologists for transforming rainfall excess to direct surface runoff is the unit hydrograph technique. Direct runoff is that water which travels over the land surface or laterally in the surface soil to a stream channel. The stream channel allows this flow to travel rapidly. Therefore, the direct runoff is ordinarily the most important element in the formation of flood peaks. Subsurface flow or "base flow" into a stream results when the groundwater table is higher than the stream surface. The groundwater contribution to streamflow does not ordinarily fluctuate rapidly due to the medium through which groundwater travels. Up to several weeks, or even a few months, and even years in some cases, may be required for a given accretion to groundwater to be discharged into the streams.

There is no practical method of differentiating between base flow and direct runoff after they have been intermixed in the stream, and the techniques of hydrograph separation are rather arbitrary. Figure 5.1

DEVELOPMENT OF HYDROGRAPH AT LOCATION OF INTEREST  
FOR A SINGLE STORM EVENT

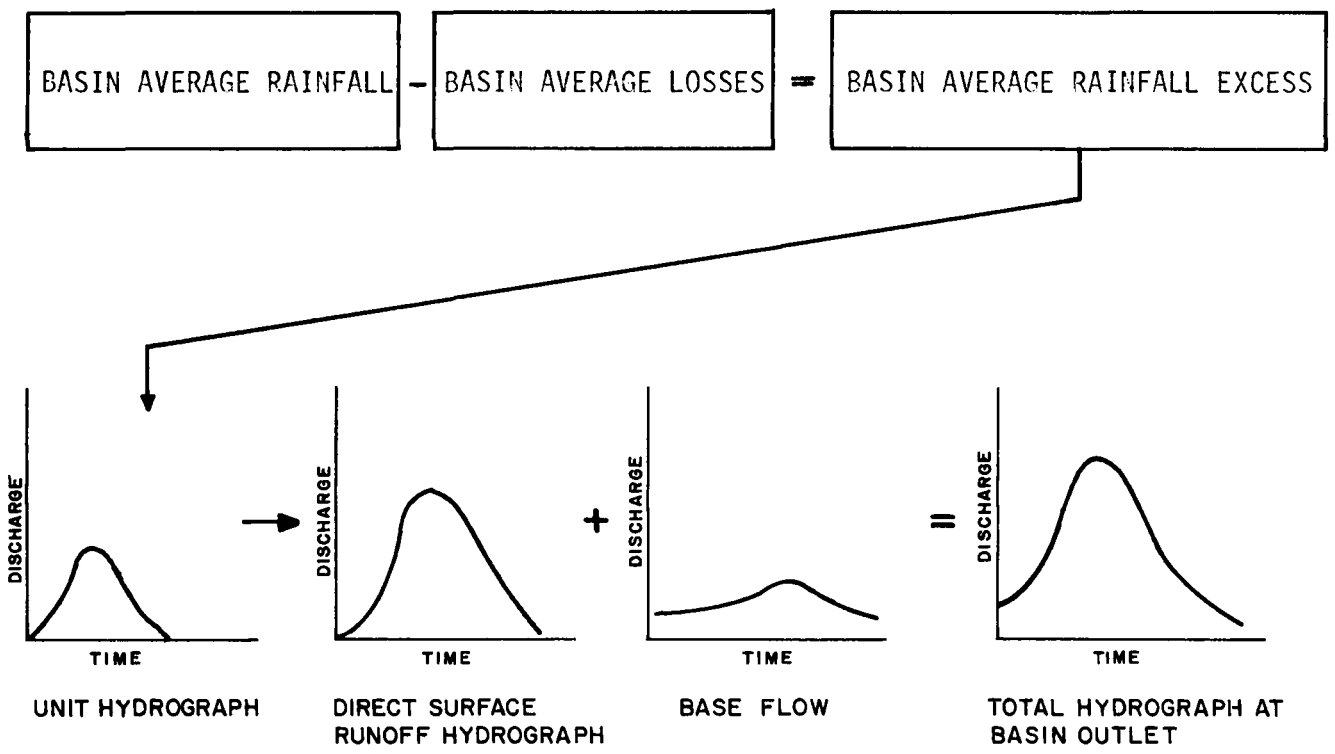
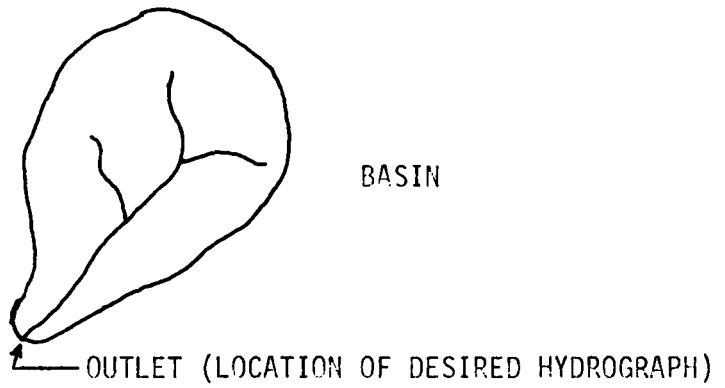


Figure 5.1 HYDROGRAPH ANALYSIS CONCEPTS

illustrates the basic procedure of developing a runoff hydrograph using the unit hydrograph technique.

### The Hydrograph

The hydrograph is usually considered as having two parts, direct runoff and base flow. The components of a hydrograph are illustrated in Figure 5.2. Hydrologic studies usually require analysis to determine one or more components of a hydrograph.

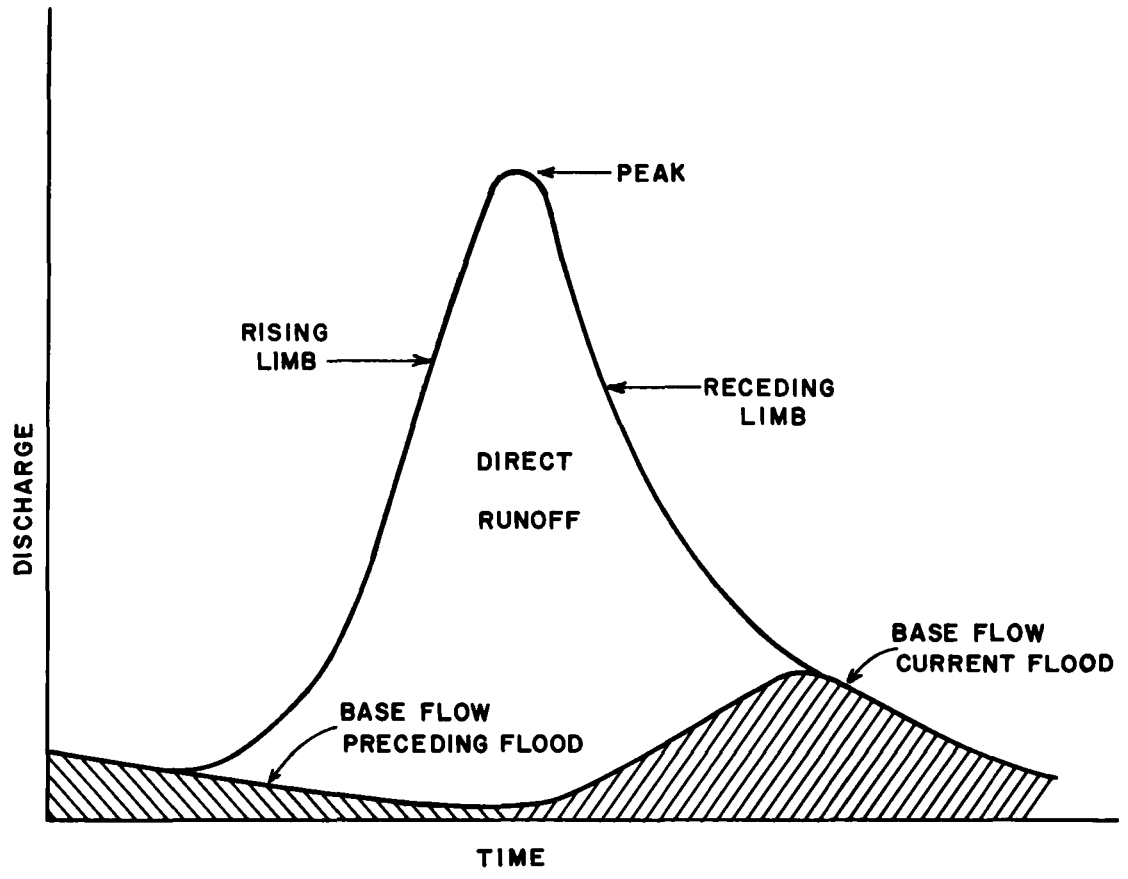
Hydrograph characteristics such as peak discharge, time to peak, and volume of runoff are based on the shape of a hydrograph, which in turn is dependent on precipitation patterns and basin characteristics of the watershed.

Precipitation Variations: Although the physical characteristics of natural basins may remain relatively constant, variations in storm characteristics will have significant effects on the shape of resulting hydrographs. They include:

- o Areal distribution of rainfall and snowmelt
- o Rainfall and snowmelt durations
- o Time intensity patterns

In general, hydrographs resulting from precipitation concentrated in the lower portions of a basin will have a rapid rise, a sharp peak, and a rapid recession, while precipitation concentrated in the upper part of the same basin will result in a hydrograph that has a slower rise and recession and a lower, broader peak. If the amount of rainfall excess remains constant and the duration is increased, the time base of the hydrograph will be lengthened and the peak will be lower. Time-intensity patterns of rainfall (amount of rainfall and corresponding time distribution of a storm) can have a significant effect on hydrographs which is directly related to basin size.

On large basins, changes in storm intensity must last for several hours to cause distinguishable effects on the hydrograph. On the other hand,



**Figure 5.2 RUNOFF HYDROGRAPH**

clearly defined peaks in the hydrographs may be caused by short bursts of rainfall lasting only a few minutes in very small basins. For large basins, valley storage tends to eliminate the effects of short-duration intensities and only major changes in the time-intensity pattern are reflected in the hydrograph. Figure 5.3 illustrates the effect precipitation patterns have on hydrograph shape.

Basin Characteristics: Up to this point, it has been assumed that the physical characteristics of a basin have remained relatively constant. But it is known that changes in the physical characteristics can and do occur from natural and manmade causes. Basin characteristics that modify hydrograph shape include:

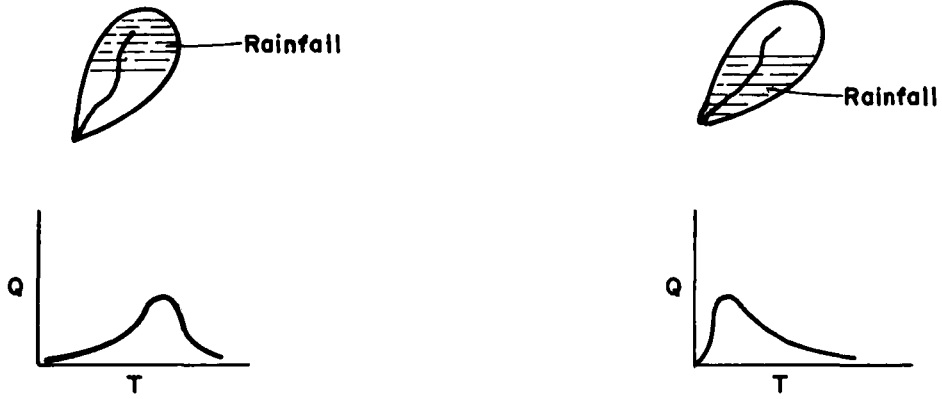
- o Size of the watershed
- o Shape of the watershed
- o Length of the main channel
- o Land and channel slopes
- o Roughness of land and channels
- o Drainage density
- o Valley storage

The size of the watershed has the greatest effect on hydrograph shape. For similar rainfall excesses and assuming other characteristics are relatively equal, the larger the watershed the greater the volume, peak, and duration of the hydrograph. The shape of the basin is also important since a hydrograph resulting from a watershed which has most of its drainage area located in the lower half will usually have quicker and higher peaks than a similarly-sized basin with its area concentrated in the upper half of its watershed.

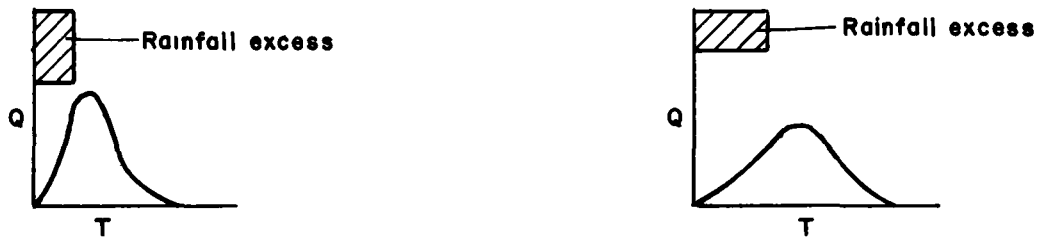
Unless extraordinary basin modifications (natural or manmade) occur, a basin's size and shape are constant. The remaining physical characteristics, however, are subject to changes over time that may cause different hydrograph shapes for similar precipitation patterns. Although they may be the result of manmade land use modifications to the watershed, particularly urbanization, other conveyance system changes such as levees, reservoirs, and channel



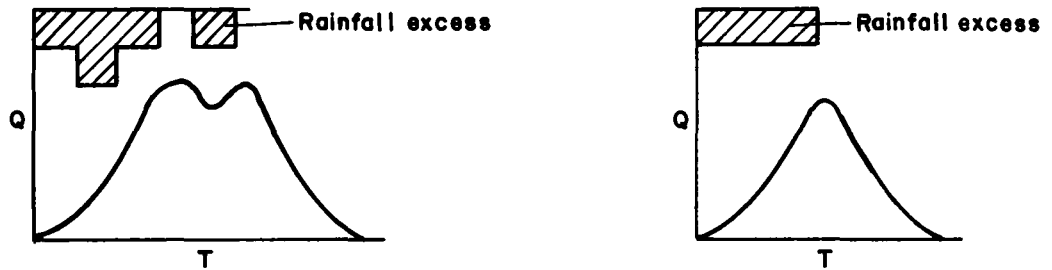
**a. AREAL DISTRIBUTION OF PRECIPITATION**



**b. RAINFALL DURATIONS**



**c. TIME INTENSITY PATTERNS**



**Figure 5.3 EFFECTS OF RAINFALL ON THE HYDROGRAPH**

modifications also result in changes to the hydrologic response of a watershed. The significance of these changes on the hydrograph depend upon how extensive they are in the watershed. Figure 5.4 illustrates the effects of different watershed sizes and shapes, channel lengths, land and channel slopes, roughness of land and channels, drainage density and valley storage on the shape of the hydrograph for similar precipitation patterns and rainfall excess.

### Streamflow Measurements

Most data used by hydrologists serve other purposes in meteorology, climatology or other earth sciences. Streamflow data are gathered principally by hydrologists for hydrologic studies. To the hydrologist, streamflow is often the desired information to be obtained from analyzing the hydrologic cycle, since hydrology is concerned mainly with estimating rates or volumes of flow or the changes in these values resulting from manmade causes.

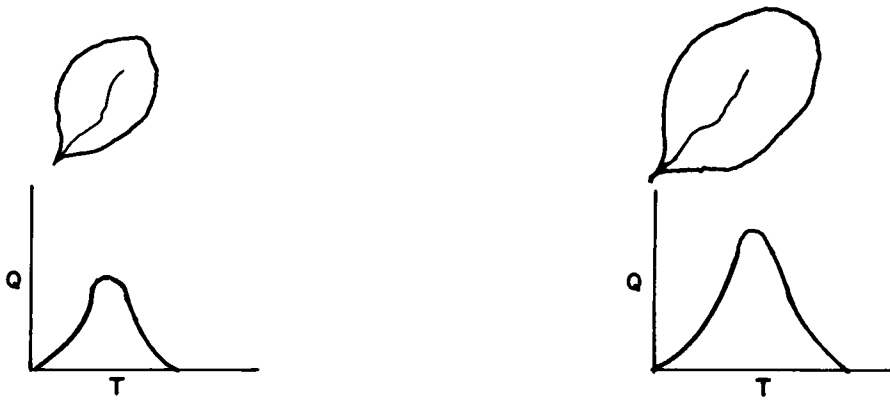
The primary types of streamflow measurements that are used in hydrologic analysis include:

- o Measurement of peak flood elevations
- o Continuous stage vs. time measurements of streamflow
- o Discharge measurements

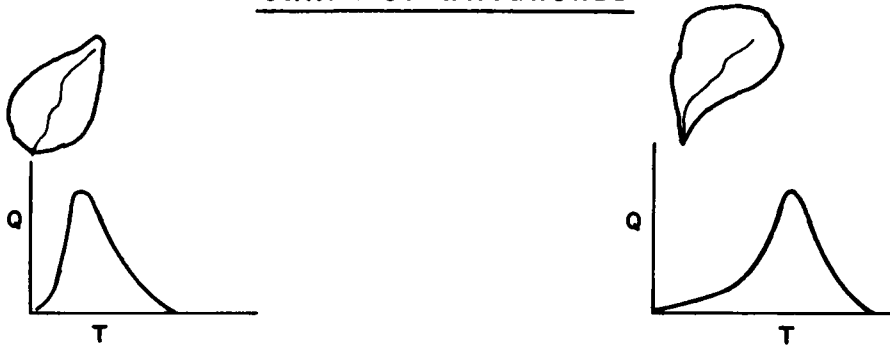
Detailed discussions of each type of measurements may be found in Linsley [1]. The following paragraphs summarize these types of measurements.

Peak Flood Elevations: These measurements may be made by peak indicator gages located along a stream or river. Often, however, this data is obtained for large historic events from highwater marks or interviews with people along the stream. This type of data becomes extremely valuable for analyzing large historical events or calibrating analytical runoff models. (See Figure 5.5a).

SIZE OF WATERSHED



SHAPE OF WATERSHED



LENGTH OF MAIN CHANNEL



LAND AND CHANNEL SLOPES

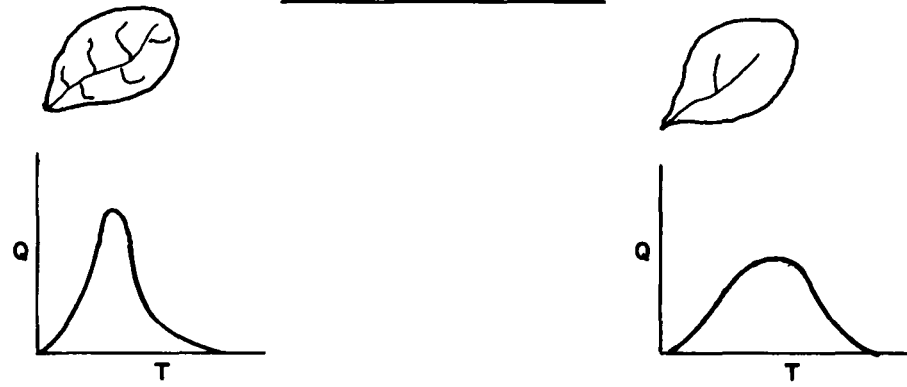


**Figure 5.4 EFFECTS OF BASIN CHARACTERISTICS**

ROUGHNESS OF LAND AND CHANNELS



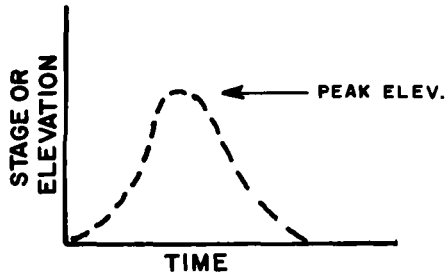
DRAINAGE DENSITY



VALLEY STORAGE

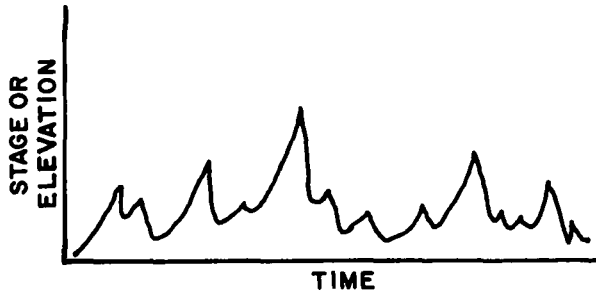


Figure 5.4 EFFECTS OF BASIN CHARACTERISTICS (Cont'd)



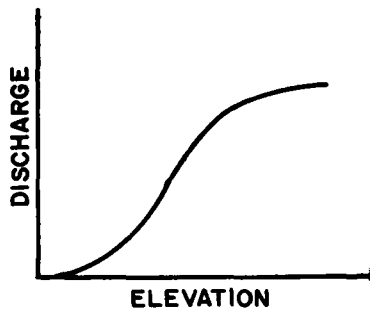
**a. PEAK WATER SURFACE ELEVATION**

Time is usually not recorded.  
(Peak indicator gage or other high water marks.)



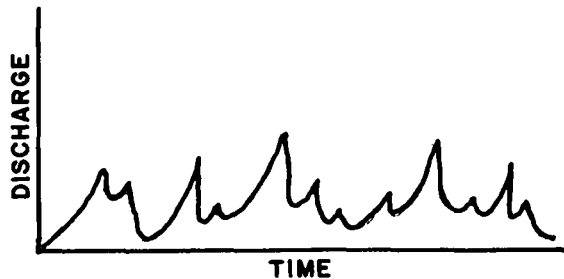
**b. CONTINUOUS RECORDING**

Stage vs time (usually made with continuous stream gage recorder).



**c. RATING CURVE**

Constructed by a series of measured flows and corresponding water surface elevations (Field Measurements).



**d. CONTINUOUS DISCHARGE HYDROGRAPH**

The most important streamflow data to an hydrologist (constructed by combining b and c above).

**Figure 5.5 TYPES OF STREAMFLOW DATA**

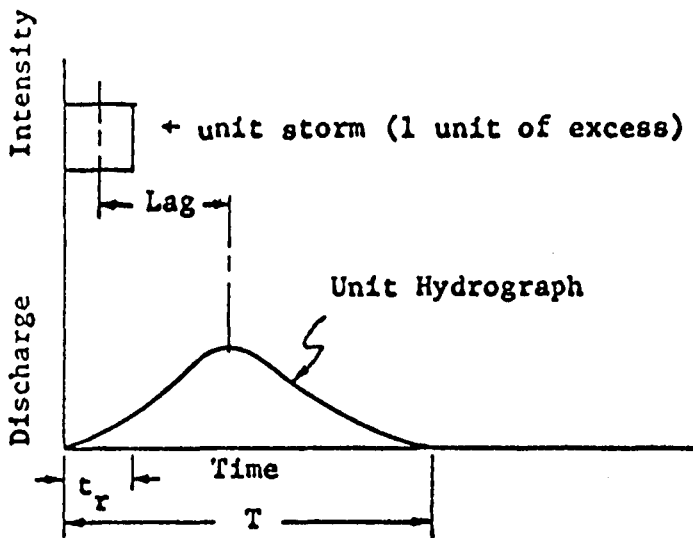
Continuous Measurements: These measurements are usually made by recording stream gages that continuously and automatically record streamstage versus time. For large rivers these measurements may be made from staff gages. This information is very valuable to the hydrologist since the total hydrograph passing a point in the stream is recorded. Continuous recorded data are extremely important for model verification and are often adjusted and transferred to ungauged basins by accounting for differences in basin characteristics and rainfall patterns. Figure 5.5b illustrates a continuous hydrograph of stages.

Discharge Measurements: Discharge measurements measure the flow rate that occurs at a specific location along a stream at a specific water surface elevation. These measurements are made manually in the field. After several measurements at different water surface elevations are made at a specific location a rating curve (elevation vs. discharge) may be constructed. Using this curve along with continuous stage recordings, runoff hydrographs (discharge vs. time) can be constructed. Volume of runoff for any desired hydrograph can then be computed. Figures 5.5c and 5.5d illustrate this procedure. Discharge measurements are usually considered 80 to 90% accurate, which is generally much higher than the accuracy of measuring precipitation or other components of the hydrologic system.

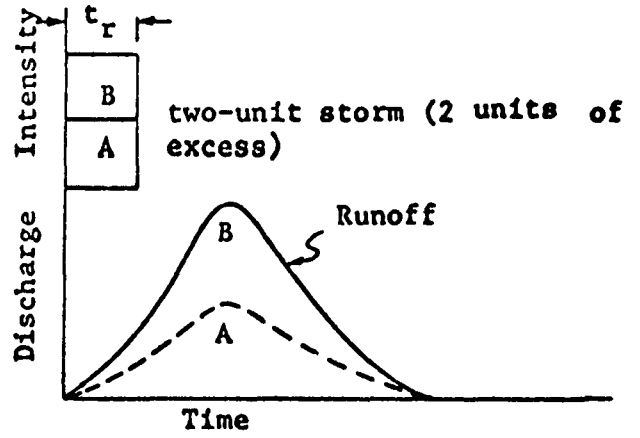
### Unit Hydrographs

The unit hydrograph is a mechanism used to transform the rainfall excess of a basin into flow at an outlet point.

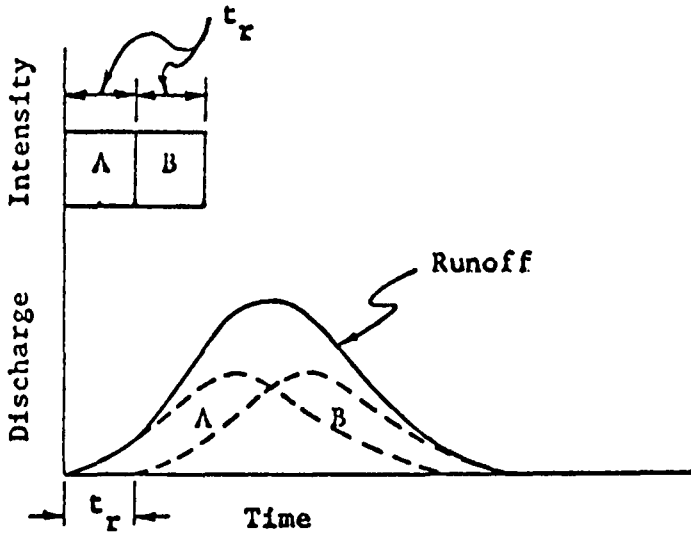
A unit hydrograph is the direct runoff that would be observed at the downstream limit of the drainage area as a result of 1 unit of rainfall or snowmelt excess occurring within the unit time interval with a given areal pattern (Figure 5.6). The unit of excess is normally taken as equal to 1 inch. Since the physical features of the basin (shape, size, slopes, soils, etc.) do not vary from storm to storm, hydrographs from storms of like duration and pattern are assumed to have the same shape, but with ordinates of flow in proportion to the runoff volumes. Thus, if two units of excess occurred in one unit time interval, then it would be expected that the



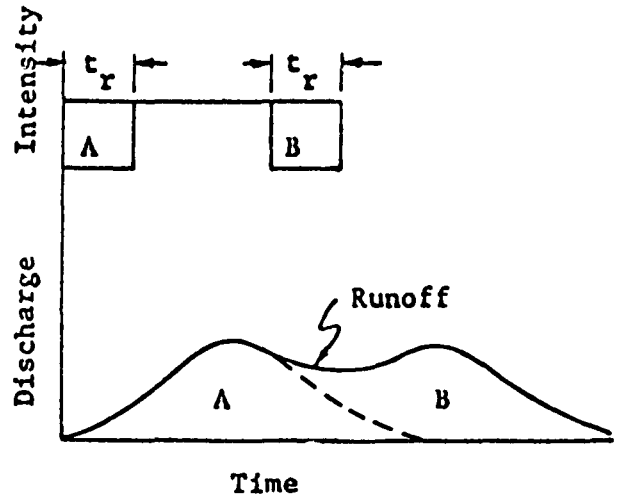
(a) Unit hydrograph



(b) Hydrograph for a 2-unit storm



(c) Hydrograph from consecutive unit storms.



(d) Hydrograph from intermittent rainfall periods.

Figure 5.6 UNIT HYDROGRAPH RELATIONSHIPS

resulting hydrograph would have the same shape as the hydrograph from one unit of excess in the same time, except that all of the ordinates would be twice as large as Figure 5.6b. As another example, (see Figure 5.6c), if one unit of excess occurred in each of two consecutive unit intervals, the resulting hydrograph would simply be the sum of the two unit hydrographs, but with the second unit hydrograph beginning one time unit later.

It is known that some assumptions of linearity involved in the unit hydrograph technique do not accurately apply. However, extensive experience indicates that the technique's limitations are generally not a major handicap, considering the quality of rainfall and snowmelt data usually available, provided the procedures involved are applied with appropriate knowledge and judgment.

Unit Hydrograph Derivation from Flood Hydrographs: A theoretically simple method of deriving a unit hydrograph involves analyzing runoff from isolated precipitation which produces reasonably uniform excess rates for a period approximately equal to the desired unit duration. Base flow is separated from the direct runoff, and the individual ordinates of the direct runoff hydrograph are divided by the volume of direct runoff. The resulting ordinates form a unit hydrograph for the specified duration of unit excess. The occurrence of floods resulting from single bursts of uniform precipitation rates are rare, and therefore, the data required to develop unit hydrographs in the above manner seldom exist. However, if individual bursts of rain in the storm result in well-defined peaks, it is sometimes possible to separate the hydrographs produced from the various bursts by estimating the recession of runoff from each burst. These hydrographs may then be used as runoff from independent storms for the development of unit hydrographs in the manner described above.

A series of unit hydrographs derived from different storms at the same location contains differences due to observation errors and other factors as described previously. For the convenience of dealing with only one unit hydrograph, and to minimize any errors due to separation of the hydrographs in the above procedure, the unit hydrographs are normally averaged. All unit hydrographs to be averaged must have the same unit duration, which may require converting to a common unit duration.



## Base Flow

Base flow is the runoff due to antecedent rainfall events or the discharge of water stored in a basin due to lakes, swamps or groundwater entering the stream's channel. In many cases base flow is insignificant, especially in computing large flood events. Base flow is often assumed to be a constant discharge throughout the duration of the hydrograph; however, where base flow is significant other methods of estimating its effects may be required.

## Runoff Hydrograph Analysis

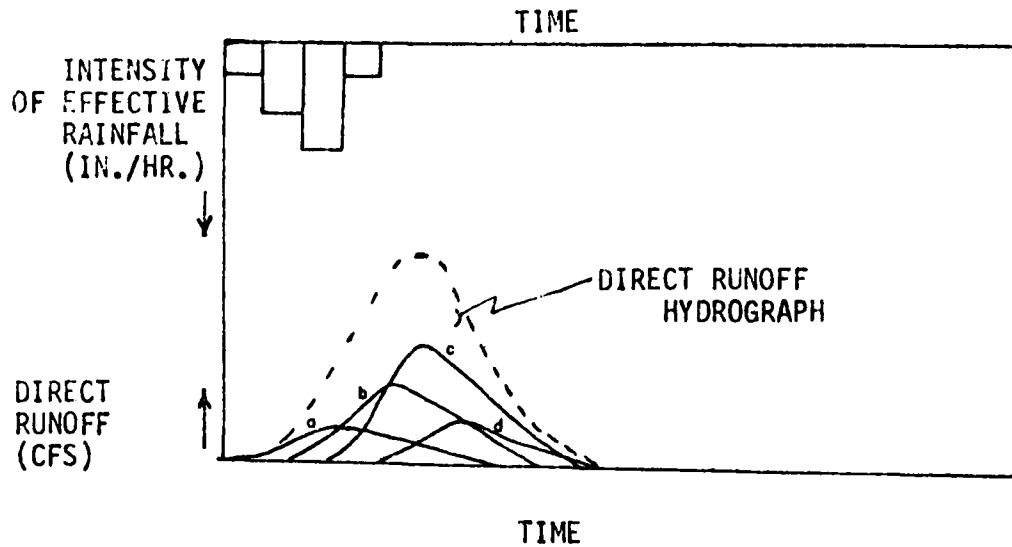
Computation of a Runoff Hydrograph: The procedure of determining a runoff hydrograph was illustrated in Figure 5.1.

The procedures requires:

- o Determination of rainfall over a basin
- o Determination of rainfall excess (loss rate analysis)
- o Determination of the response at the outlet of a basin (unit hydrograph)
- o Determination of base flow

Figure 5.7 illustrates an example computation of a runoff hydrograph. It should be noted that the duration interval associated with a unit hydrograph must be the same as the effective rainfall time increments. Techniques are available for changing the unit duration of a unit hydrograph, for example for converting a 1-hour unit hydrograph to a 2-hour unit hydrograph.

Analysis of Complex Watersheds: Hydrograph analysis of complex watershed systems requires subdividing the watershed into subbasins, computing the runoff hydrograph for each subbasin and combining and translating (routing) the hydrographs throughout the watershed (See Figure 5.8). The reasons for subdividing watersheds are:

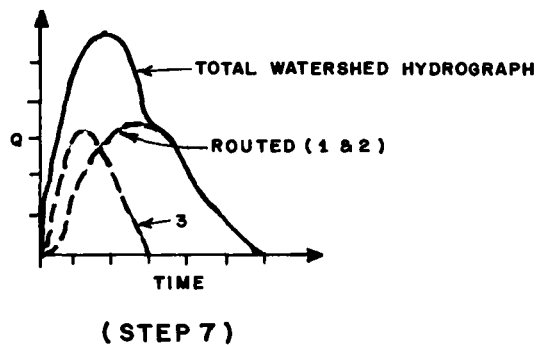
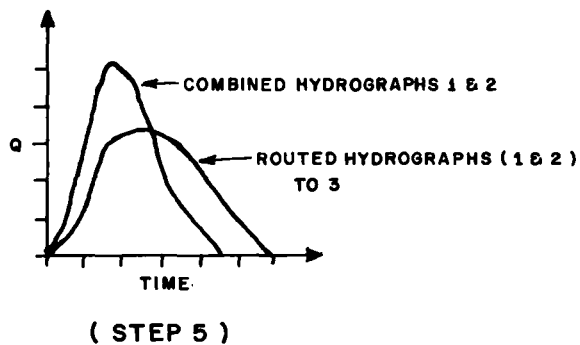
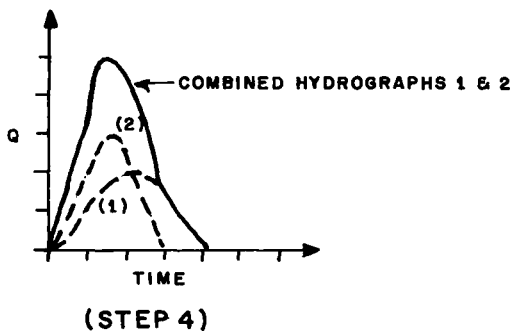
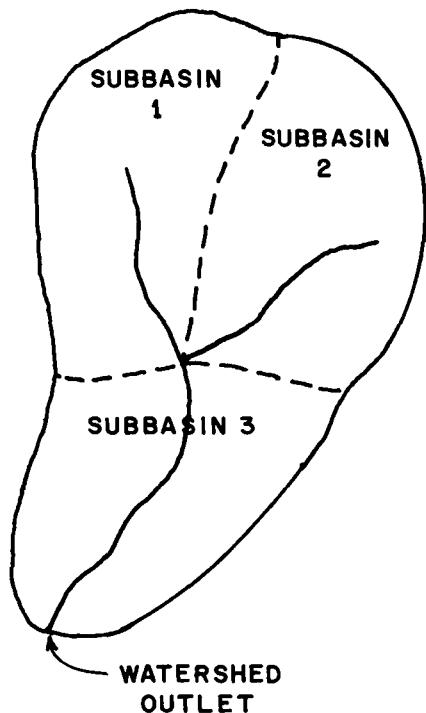


Time (Hours)	1-HR UHG (cfs)	Effective Rainfall (in)	Direct Runoff (cfs)				Sub-Total	Base Flow cfs	Total Discharge cfs
			(a)	(b)	(c)	(d)			
0	0								
1	10	1.0	10				10	20	
2	100	2.0	100	20			120	130	
3	200	3.0	200	200	30		430	440	
4	150	1.0	150	400	300	10	860	870	
5	100		100	300	600	100	1100	1110	
6	50		50	200	450	200	900	910	
7	0		0	100	300	150	550	560	
				0	150	100	250	260	
					0	50	50	60	
						0	0	10	
<b>Totals</b>	<b>610</b>	<b>7.0</b>	<b>610</b>	<b>1220</b>	<b>1830</b>	<b>610</b>	<b>4270</b>	<b>100</b>	<b>4370</b>

Figure 5.7 RUNOFF HYDROGRAPH COMPUTATION

**BASIC HYDROGRAPH**  
**ANALYSIS PROCEDURE**

- 1) Determine hydrologic subbasin data
  - a. average rainfall
  - b. loss rate criteria
  - c. base flow
- 2) Determine unit hydrographs for each subbasin
- 3) Construct runoff hydrographs at each subbasin outlet
- 4) Combine hydrographs from subbasins 1 & 2
- 5) Route combined hydrograph (1 & 2) to outlet of subbasin 3
- 6) Compute runoff hydrograph at outlet of subbasin 3
- 7) Combine the routed hydrograph with subbasin 3's hydrograph to get the total watershed's runoff hydrograph.



**Figure 5.8 HYDROGRAPH ANALYSIS OF A WATERSHED SYSTEM**

- o The watershed is large and precipitation does not occur uniformly over the basin, and/or basin characteristics change significantly in the system
- o It is desired to place less emphasis on the linear concepts of the unit hydrograph and more on routing throughout the watershed
- o Flood hydrographs are to be determined at locations of interest throughout the watershed, in order to:
  - evaluate existing or proposed facilities
  - determine flood hazard potential
  - provide input into economic evaluations or environmental assessments

QUESTIONS  
CHAPTER 5  
HYDROGRAPH ANALYSIS

1. How reliable are streamflow measurements? Name the type of recorded data that is important to a hydrologist.
2. Describe a hydrograph and its use in evaluating alternative future land uses and flood control projects.
3. Discuss the effects of the following on the shape of the runoff hydrograph (peak, time to peak, volume).
  - a. Rainfall occurring in the upper portions of the watershed as opposed to the lower portion.
  - b. A storm of 4 inches of rainfall occurring in 4 hours as opposed to 24 hours.
  - c. Shape of the watershed.
  - d. Slope of the watershed.
  - e. Increased imperviousness in the watershed.
  - f. Natural storage.

## DISCUSSION TO QUESTIONS

### CHAPTER 5

#### HYDROGRAPH ANALYSIS

1. Discharge measurements are usually considered 80-90 percent accurate, which is generally much higher than the measured rainfall and its areal distribution. The most important evaluation information to hydrologists is the continuous streamflow recording (stage vs. time). Streamflow measurements and peak flood elevations are also valuable sources of data used by hydrologists.
2. A hydrograph is the time distribution of rainfall excess at the outlet of a watershed. The volume of the runoff hydrograph is equal to the amount of rainfall excess that occurs over the watershed. Hydrograph analysis concepts are used in evaluating alternative future land uses and flood loss reduction measures. The types of floods used in these analyses include historic events and hypothetical frequency, Standard Project and Probable Maximum floods.
3. The meteorological and watershed characteristic affects on the peak, time to peak and volume of the hydrograph are:
  - a. Runoff hydrographs resulting from rainfall occurring in the upper portions of a watershed will have a later peak than rainfall concentrated in the lower portion of the watershed.
  - b. The hydrograph resulting at the outlet of the watershed from a 4 inch storm occurring in 4 hours will have a quicker, higher peak and corresponding volume of runoff than a 4 inch storm occurring in 24 hours.
  - c. Watersheds with the largest portion of the drainage area concentrated in the lower reaches will have a quicker peak than watersheds with the drainage area concentrated in the upper portions.

## DISCUSSION TO QUESTIONS (Continued)

- d. Steep watersheds generally have straighter and narrower flood plains, and consequently, less natural storage and travel times than those with mild slopes. Therefore, steep watersheds tend to result in hydrographs that peak quicker and higher than mild slope basins of similar drainage areas.
- e. Increased imperviousness in a basin tends to cause runoff hydrographs to peak sooner and higher with more volume.
- f. Basins with significant natural storage result in significant natural storage result in hydrographs with peak discharges that occur lower and later than those watersheds with small storages.

CHAPTER 6  
HYDROGRAPH ANALYSIS OF UNGAGED BASINS

General Concepts

The lack of meteorological and hydrological data represents one of the greatest obstacles in hydrologic analyses. The hydrologist is usually faced with few rainfall measuring sites and even fewer streamflow measuring stations. The hydrologist must, therefore, use some mechanism to predict or forecast the peak, volume or rate of runoff for events, or situations of interest without the use of historical records as a check.

The method used for hydrologic analysis of an ungaged area depends upon many factors including:

- o Type of information required
  - peak flow
  - volume
  - rate of runoff over an extended period of time
  
- o Type of data available
  - rainfall
  - basin characteristics
  - information from previous studies
  - experience of hydrologist
  
- o Characteristics and location of the watershed being studied
- o Familiarity with analytical techniques and methods
- o Study time frame and manpower available

Numerous techniques can be used to evaluate the hydrology of ungaged watersheds. Those discussed in this chapter are:

- o Direct transfer of information from a gaged to an ungaged watershed
- o Simplified methods and formula
- o Statistical methods and regional analysis
- o Methods utilizing generalized rainfall-runoff relationships



## Direct Transfer of Hydrologic Information

The concept of this approach is to transfer hydrologic information and relationships from a gaged to an ungaged watershed under the assumption that the two watersheds are hydrologically similar.

The criteria for determining the hydrologic similarity between two watersheds include:

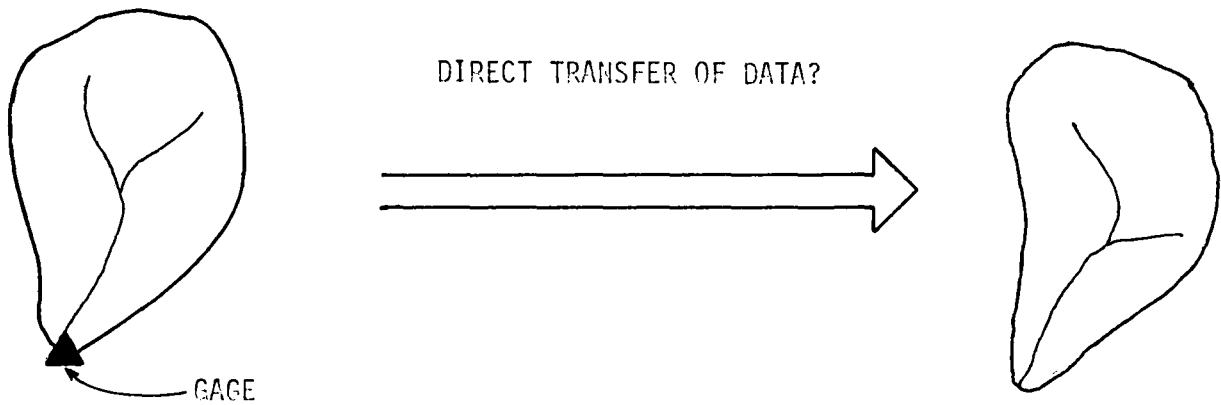
- o Similar meteorological regime
  - Storm patterns and rainfall intensities
  - Average annual rainfall
  
- o Basin characteristics
  - Soils
  - Geology
  - Topographic relief
  - Channel slopes
  - Land use (% urbanization is critical)
  - Drainage density
  - Drainage areas (areas should not differ by more than an order of magnitude)

The method of direct transfer of information usually requires minor adjustments in data for differences in rainfall and basin characteristics, and can be applied in two ways: transfer of entire historical records or transfer of single storm events or portion of those events (See Figure 6.1).

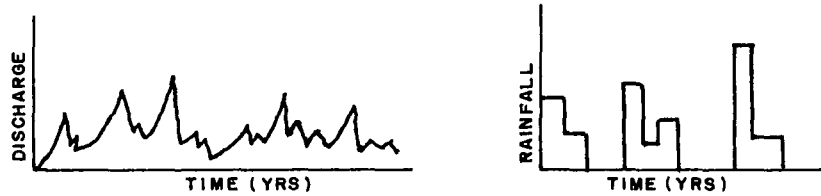
The applicability of the direct transfer of information approach is highly dependent upon the assumptions of hydrologic similarity. If a significant amount of adjustment is needed to transfer hydrologic information from the gaged to ungaged watershed, this method should not be used. When assumptions are met, however, the hydrology of an ungaged watershed can be estimated in a quick and easy fashion. The method is often used as a quick check of other more sophisticated analysis for "reasonableness" of results by comparing records of similar sized watersheds with the ungaged basin.

GAGED BASIN

UNGAGED BASIN



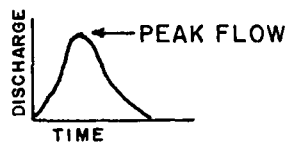
1. BASINS MUST BE METEOROLOGICALLY AND HYDROLOGICALLY SIMILAR.
2. WHAT DATA IS TO BE TRANSFERED?
  - a. ENTIRE HISTORIC RECORD



- b. SINGLE EVENT



- c. PORTION OF DATA



3. WHAT ADJUSTMENTS ARE REQUIRED?

Figure 6.1 DIRECT TRANSFER OF DATA

## Simplified Method

Numerous formulas have been developed over the years which allow the computation of certain components of the hydrograph, usually peak discharge. These techniques (often referred to as "quick and dirty") are designed for small, simple watersheds and usually consist of an empirical equation that considers certain watershed characteristics. Most of the simplified methods calculate only peak discharges.

The Rational Method is a commonly used equation for computing peak flow on a small watershed. It is usually applicable to watersheds less than a square mile, with caution required for larger areas. The peak discharge (Q ) in cfs is computed as follows:

$$Q = CIA$$

where:

C = Runoff coefficient relating proportion of rainfall contributing to peak runoff (from tables)

I = Runoff intensity (in/hr) for a duration equal to the time of concentration of the watershed

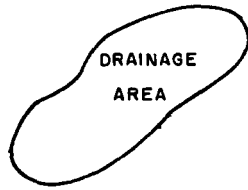
A = Drainage in acres

Figure 6.2 illustrates a conceptual application of the rational method.

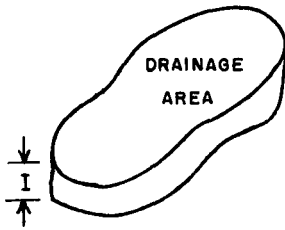
The rational method continues to be widely used because of its notoriety and simplicity. The method is only valid, however, when the following assumptions are met:

- o Rainfall intensity is uniform over the duration of the storm
- o Rainfall duration lasts long enough for the entire area to contribute to discharge.
- o The hydrologic system is not complex

1. The watershed's drainage area may be thought of as a plane surface.

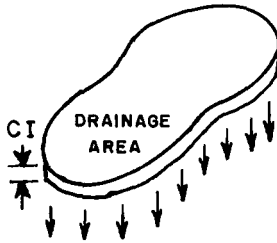


2. Rainfall rate distributed uniformly over the basin.



$I = \text{Rainfall (in./hr.)}$

3. Small holes are punched in the surface to remove proportion of rainfall that does not contribute to the peak discharge.



$CI = \text{Proportion of rainfall rate contributing to peak discharge}$

$(1-C)I = \text{Rainfall rate not contributing to peak discharge.}$

4. The runoff ( $Q_p$ ) becomes equal to the precipitation rate less the loss.



Figure 6.2 CONCEPTS OF THE RATIONAL FORMULA

Most of the other simplified methods follow the same general concepts of the rational equation and are usually restricted to drainage and municipal engineering investigations for small drainage areas less than a square mile.

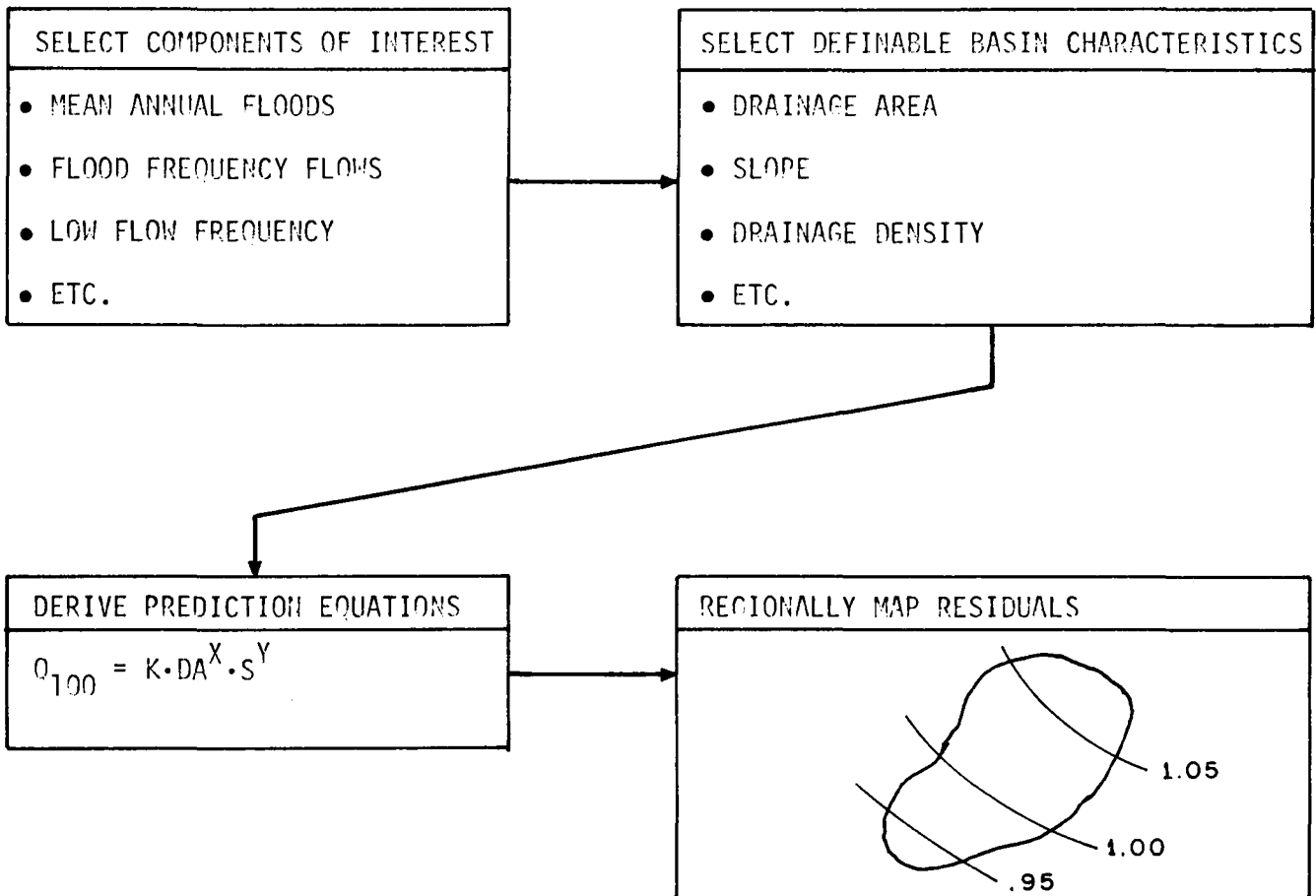
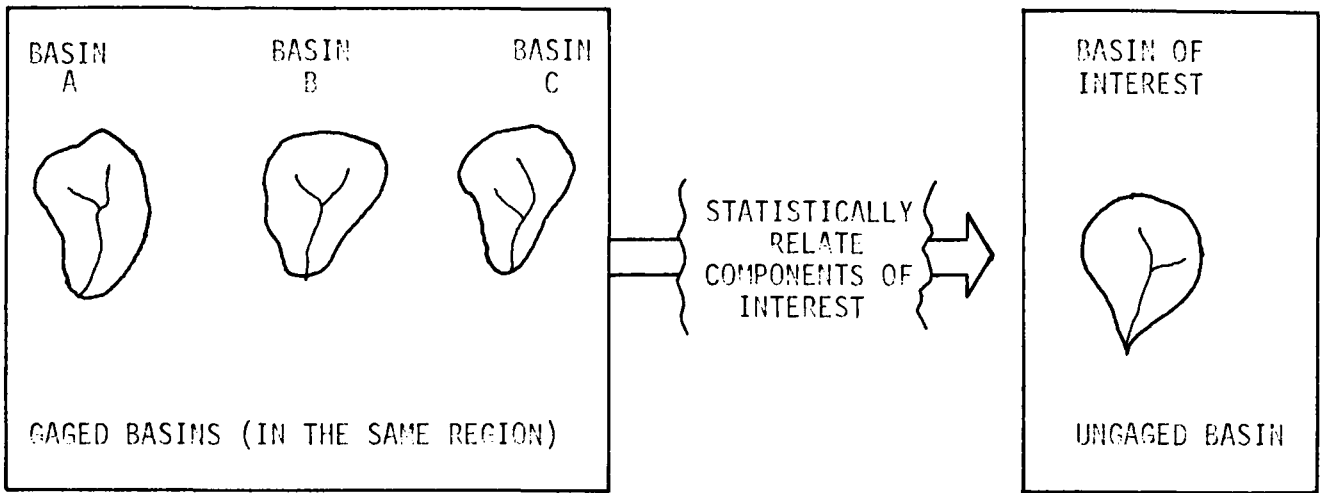
### Statistical Methods and Regional Analysis

Regional analysis consists of the development of equations, charts, maps, etc., that permit "reading out" information that is needed for a particular type study or other modeling input. The analysis is on a regional scale whereby the only knowledge available may be from a map. The classic application of regional analysis is that of regional frequency analysis. Charts and equations are developed that allow the derivation of exceedance frequency curves for ungaged areas. The characteristics of frequency curves are correlated with basin characteristics.

A regional analysis usually consists of the following steps (see illustrative example in Figure 6.3):

- o Select components of interest, such as mean and peak discharge
- o Select definable basin characteristics of gaged watershed: drainage area, slope, etc.
- o Derive prediction equations with single or multiple linear regression analysis
- o Map and explain the residuals (differences between computed and observed values) that constitute "unexplained variances" in the statistical analysis on a regional basis

Regional analysis is a useful technique for hydrologic analysis of ungaged areas and is widely used in the Corps. The technique is used to develop prediction equations that produce desired answers directly (peak discharge) or may be used to provide regional parameters necessary for more detailed modeling of a system. The method must be used with caution, however, since only one or a few components of the hydrologic system are included in the analysis.



**Figure 6.3 STATISTICAL METHODS AND REGIONAL ANALYSIS**

## Generalized Rainfall-Runoff Relations

The use of hydrograph analysis concepts may be applied to ungaged watershed by the development and application of generalized functions for estimating loss rates, unit hydrographs and base flow. The unit hydrograph, being considered as having a unique relationship for a basin regardless of the storm, losses, etc., has received the most attention by researchers since it is the most stable component of the rainfall-runoff analysis process.

Loss rates are extremely variable and are dependent on both precipitation patterns and basin characteristics. As a consequence, there is a tendency to adopt a "criteria" approach where loss rates are chosen in a policy framework rather than being analyzed.

- o The criteria approach is probably appropriate for computing large floods such as for spillway design, etc., since losses tend to be small for the larger or rare events. This concept is less appropriate when computing a range of flood events that are to be used in system performance evaluations.
- o A whole range of rainfall intensities and loss rates will give rise to the same runoff event. More study is obviously needed on the joint occurrence of events as they relate to runoff.

General studies can and have been made relating loss rates and analytical loss rate functions to soil type, land use cover, antecedent precipitation and rainfall intensity, although the results have not been too promising. The Soil Conservation Service (SCS) has probably done the most work in generalizing loss rate functions through their curve number technique which includes losses determined by land use cover and soil types with allowances for antecedent moisture conditions. The Corps has done only limited work in this area, concentrating primarily on regional relations in generating loss rate functions for ungaged basins.

Generalized unit hydrographs (synthetic unit hydrographs) are usually developed for ungaged basins in two steps. First, an equation or procedure must be devised that will allow a unit hydrograph to be computed. Second,

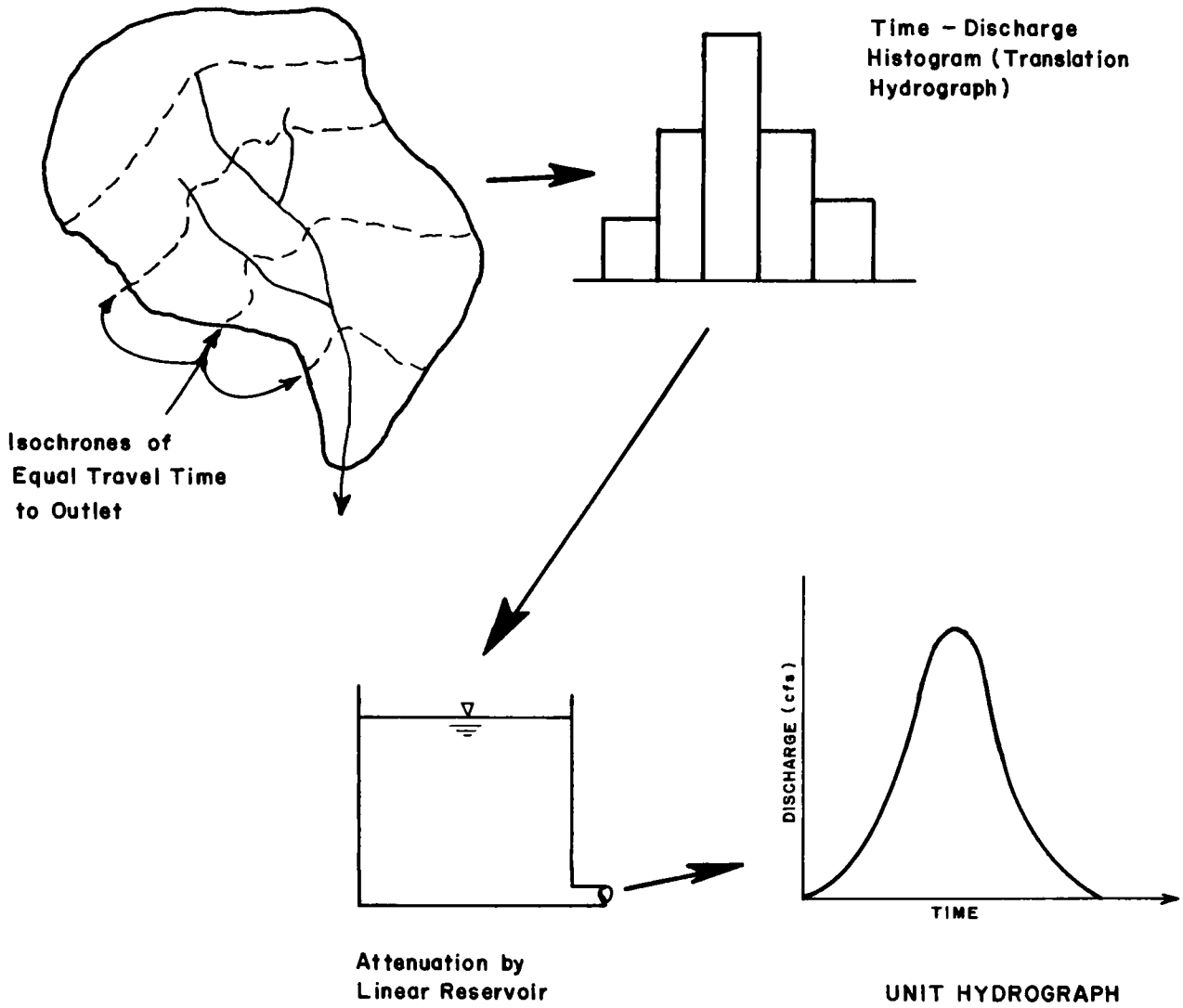
the procedures (or equation) must be related to definable basin characteristics. The simplest and most direct method is to transfer a unit hydrograph from an adjacent gaged basin of similar hydrometeorological characteristics with simple adjustments. This technique is fairly common, however, it is usually difficult to locate "similar" basins. More complex and generally applicable procedures include deriving parameters that describe the unit hydrograph, and transferring the parameters with some adjustments. The two most common methods used in the Corps are the synthetic procedures of Clark and Snyder. Because of its direct relationship to land uses the SCS triangular unit hydrograph is expected to come into wider use.

Clark's Unit Hydrograph: The Clark procedure for deriving a synthetic unit hydrograph involves developing a translation hydrograph, as shown in Figure 6.4, that depends upon the shape of the basin and its time of concentration (time of travel from the furthest point in a watershed to the outlet) and then routing the translation hydrograph through a hypothetical storage reservoir that is a proxy for the natural storage within the basin. The major advantage of this procedure is that a unit hydrograph can be directly computed from two parameters which define the time of concentration and the basin storage characteristics. The two parameters can be related to basin characteristics such as area and slope through regression analysis based on similar gaged basins. Another main advantage of the Clark's method is that it is readily adaptable for computer applications, and is being used more and more in the Corps.

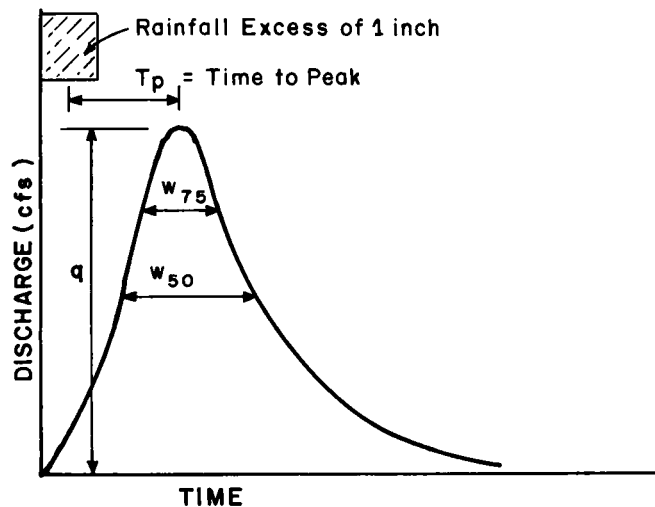
Snyder Method: The Snyder method is based on the concept that a unit hydrograph can be developed from information relative to the timing of the peak and the degree of concentration of runoff near the peak. The method as generally applied requires hand shaping of the unit hydrograph. Coefficients describing the "time to peak" and "runoff concentration near the peak" are usually developed for adjacent gaged areas and transferred directly to the area of interest. The technique is popular in many Corps districts especially in noncomputer-oriented applications. A definition sketch of the Snyder procedure is shown in Figure 6.5.

Soil Conservation Service Triangular Unit Hydrograph: This method is based on the concept that the unit hydrograph can be represented by a





**Figure 6.4 CONCEPTS OF THE CLARK UNIT HYDROGRAPH**



**Figure 6.5 CONCEPTS OF THE SNYDER UNIT HYDROGRAPH**

triangular hydrograph that is derived from a single parameter which relates to the time response of the peak. The concept is illustrated in Figure 6.6.

The peak rate of discharge ( $q_p$ ) in cfs can then be described by the following:

where:

$K$  = Constant

$A$  = Drainage Area in square miles

$Q$  = Flow volume (1 inch for the unit hydrograph)

$T_p$  =  $D/2 + L$  (in hours)

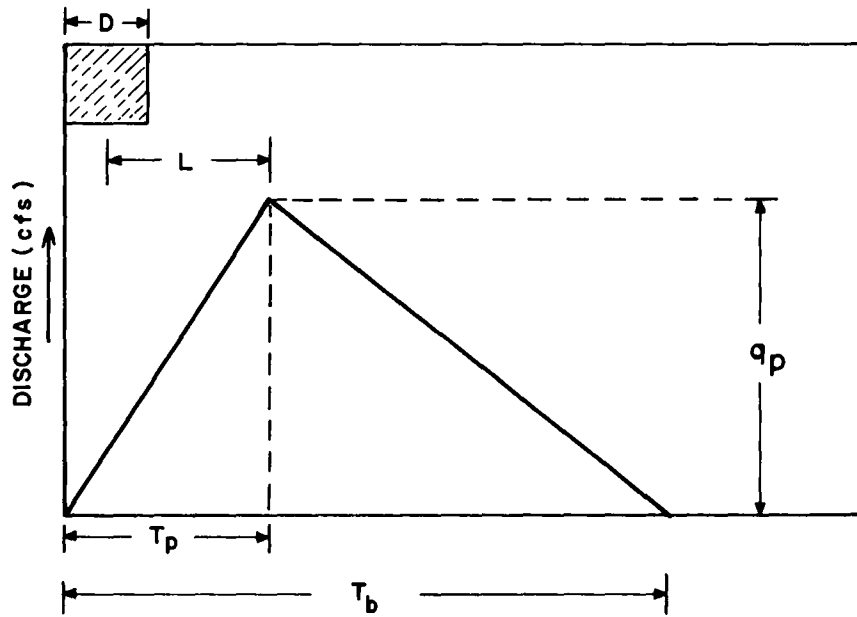


Figure 6.6 CONCEPTS OF THE SCS UNIT HYDROGRAPH

QUESTIONS  
CHAPTER 6  
HYDROGRAPH ANALYSIS OF UNGAGED BASINS

1. The simplified formulas such as the Rational Method are used primarily for what type of studies?
2. When is direct transfer of hydrologic data applicable and how is statistical analysis used in the development of information for ungaged basins?
3. As a project coordinator of planning investigations, what type of analysis would you expect a hydrologist to use for the following studies involving ungaged watersheds.
  - a. A storm sewer design for a 300-acre watershed.
  - b. A complex urban watershed.
  - c. A flood plain management investigation of a watershed with numerous gaged basins in the vicinity of the watershed of interest.
  - d. A phone call from a graduate student wanting to know the approximate peak 100-year discharge on a simple small watershed with a drainage area of 5 square miles.

DISCUSSION TO QUESTIONS  
CHAPTER 6  
HYDROGRAPH ANALYSIS OF UNGAGED BASINS

1. Simplified equations, in particular the rational formula, are commonly used in municipal engineering investigations involving small watersheds, such as, the design of a storm sewer system.
2. The direct transfer of hydrologic data is applicable for basins that are hydrologically and meteorologically similar. Statistical analysis techniques are used to derive desired prediction equations for ungaged basins by using definable basin characteristics of nearby gaged watersheds and mapping the residuals of the unexplained differences.
3. A hydrologist would probably use the following type of analysis for investigating an ungaged watershed:
  - a. A form of the rational equation for designing a storm sewer system for a 300-acre watershed.
  - b. Rainfall-runoff analysis for a complex urban watershed.
  - c. Statistical methods of relating the gaged data to the ungaged watershed for a flood plain management investigation of a simple system. If the watershed is complex a rainfall-runoff analysis would also be required.
  - d. A phone call from a graduate student wanting to know the approximate peak 100-year discharge on a 5 square mile basin could be answered quickly by using direct transfer of data from a similar nearby gaged watershed, simplified equations, or existing statistically derived prediction equations developed for the region.

## CHAPTER 7

### HYDROGRAPH ANALYSIS IN URBAN AREAS

#### Introduction

The objective of analyzing urban runoff is to develop quantitative information on the volume and rates of runoff for use in planning and design of urban water management systems, or to provide information for other planning functions on the flood hazard potential of the urban area.

Urbanization affects the physical characteristics of a watershed and may result in significant changes to the shape of the hydrograph (volume, peak and time to peak). Methods of analysis depend upon the objectives of the study (storm drainage, flood control, pollutant control), the expected availability of information, time and funds, and the technology available for performing the analysis.

#### Effects of Urbanization

Urbanization of a watershed often results in significant changes to the physical characteristics that increase the volume of runoff, and reduces travel times, causing quicker and higher peak discharges. Other effects may be water quality degradation due to man's activities, and a reduction of groundwater recharge. The following physical changes of a basin generally occur with urbanization:

- o Pervious surface is modified
- o Depression storage is significantly reduced
- o Impervious areas are increased
- o Channels are widened, straightened, and smoothed
- o Secondary drainage systems are constructed
- o Natural storage is reduced

Each of these land use changes may or may not individually have a major effect on the hydrograph, however, when they are combined their is a greater volume of runoff and quicker and higher peaks to the hydrograph usually result.

Hydrograph Volume: Urbanization typically results in land use modifications that reduce the watershed's losses, thereby increasing the rainfall excess and volume of runoff. The modifications include increases in impervious surfaces, reduction of depression storage areas, and the reduction of natural vegetation cover. Impervious surfaces are roofs, streets and roads, parking lots, etc., which prohibit infiltration. Depression storage areas may be natural swales, sinks, swamps, marshes, etc., which trap runoff in isolated storage areas that do not contribute to the runoff of the watershed's major conveyance system. These areas are often filled or drained by secondary drainage systems when urbanization occurs.

Timing of the Hydrograph: The time to peak of a hydrograph may be significantly reduced by urbanization factors such as decreased land surface, channel roughness, natural flood plain storage, and channel modifications, etc., which result in higher and quicker peak discharges. However, the higher peak discharges may have a beneficial effect in some circumstances. The urbanization of the lower portion of the watershed may allow those flows to pass more quickly out of the system, prior to being appreciably affected by the upper reach runoff. Another situation is the confluence of two hydrologically similar tributaries which results in simultaneous peak discharges occurring at their confluence. If one tributary becomes urbanized its hydrograph would peak quicker and cause a reduced combined flow below their confluence.

Peak Discharges: The primary concern of hydrologists when urbanization occurs is increases in peak discharges and corresponding flood heights. This is the result of reduced travel time of the hydrograph, reduction in natural storage and increase in the volume of runoff.

### Development of a Watershed

To illustrate the effects of urbanization on the hydrologic response of a watershed, a hypothetical sequence of development may be used. Under natural conditions the basin has a meandering stream, and a land cover of natural vegetation. Losses in the basin are largely due to depression storage, interception, transpiration, and infiltration. The runoff response

is slow because of the meandering stream and the roughness of the land surface and channel. The hydrograph at the outlet has a flat, rounded peak, reflecting the large amount of natural storage and slow response time of the system as shown in Figure 7.1.

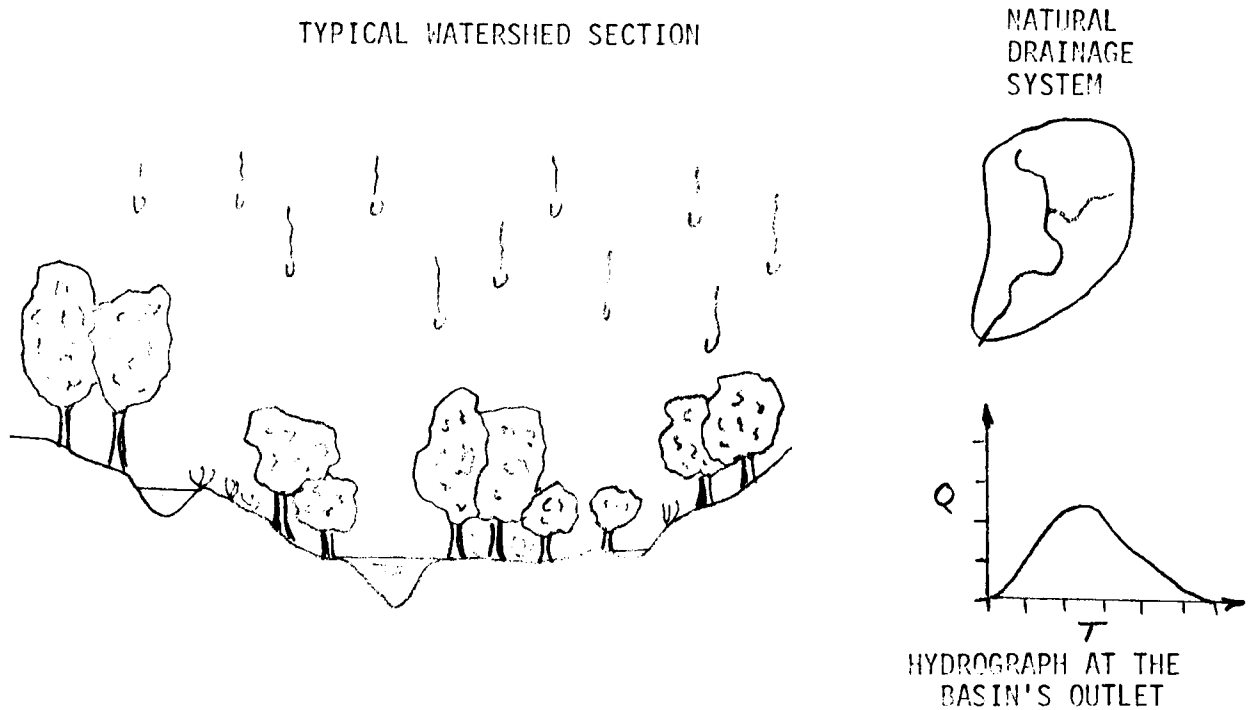


Figure 7.1 NATURAL WATERSHED RESPONSE

Modification of Pervious Surfaces: In this condition the land surface has been graded and cleared with grass planted prior to urban development. Depression storage has been reduced along with some interception and transpiration losses resulting in an increase in volume of runoff. The overall roughness of the land surface has also been reduced causing a quicker travel time of the runoff. With the exception of depression storage, the natural storage in the system has been preserved. The overall effect on the hydrograph will be a slightly quicker and higher peak and a small increase in volume as shown in Figure 7.2.



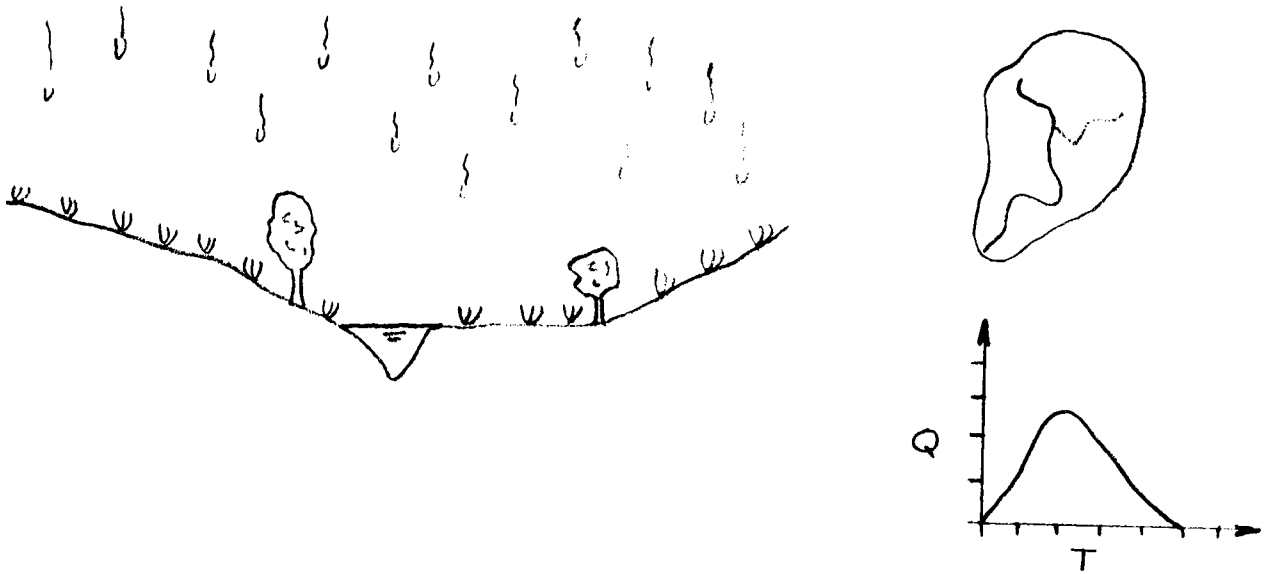


Figure 7.2 PERVIOUS SURFACE RESPONSE

Increase in Impervious Surfaces: Next in the sequence, urbanization (houses, streets, industrial and commercial development) has occurred with a large increase in the amount of impervious surfaces. The primary result will be a significant increase in the volume of runoff due to the reduction of infiltration losses as shown in Figure 7.3. Other effects will be a quicker runoff of water over land surfaces (due to reduced roughness of the basin) into the channel conveyance system causing a higher peak discharge. Natural storage has again been preserved, maintaining the basic response time of the major conveyance system.

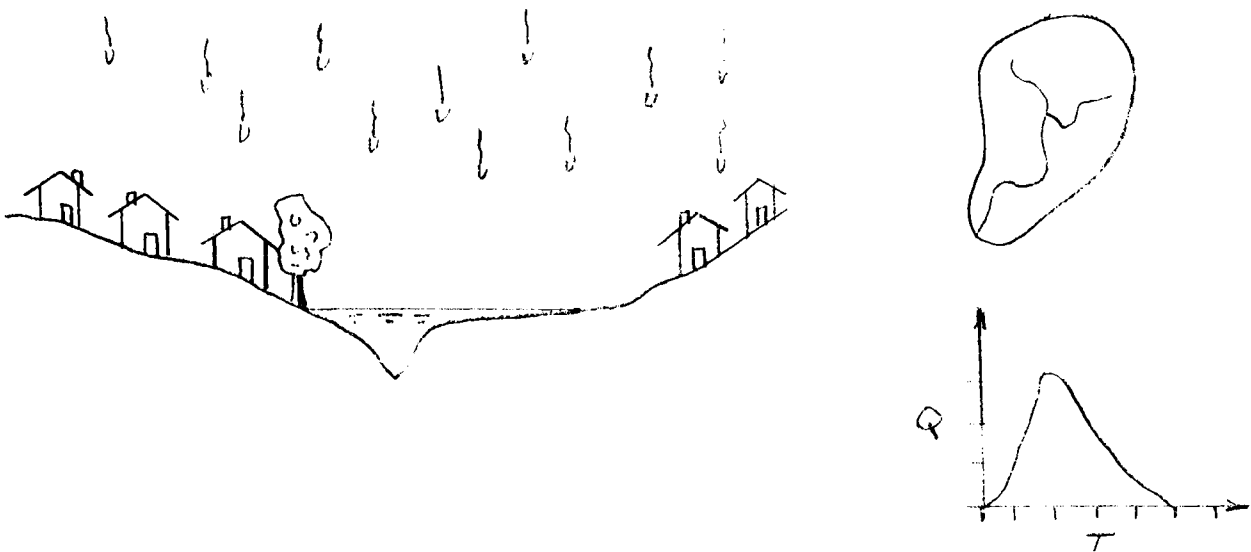


Figure 7.3 IMPERVIOUS SURFACE RESPONSE

Channel Modifications: In this phase of development extensive channel modifications have occurred by straightening, modifying the channel geometry by increasing its capacity, and reducing the roughness of its sides. The straightening of the channel, which increases the steepness of its slope, will have the most adverse effect on the shape of the hydrograph by reducing the travel time of the system and causing quicker and higher peaks as shown in Figure 7.4. Reducing the channel roughness will have a similar effect. (Maintenance of straightened and over-sized channels often becomes an expensive and major problem).

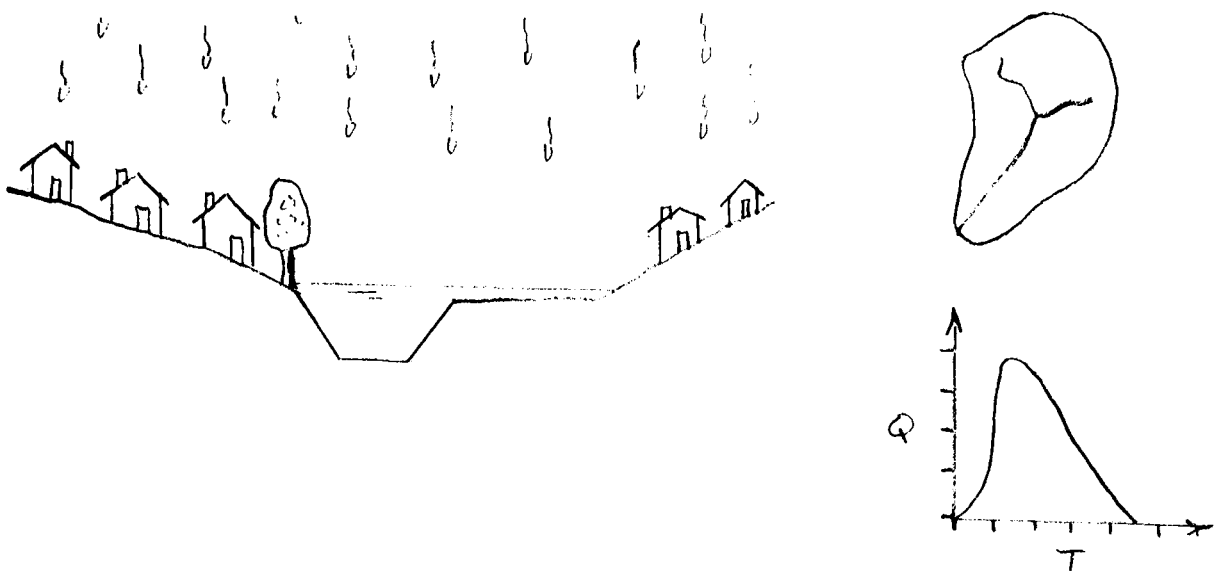


Figure 7.4 MODIFIED CHANNEL RESPONSE

Secondary Drainage Systems: The implementation of secondary storm sewers provide an expedient mechanism of removing storm runoff from local areas into the major conveyance system. The secondary system increases the drainage density of the basin and results in quicker travel times of overland flow and reductions in depression storage areas. The result is higher peak discharges and if depression storage is great, a larger volume of runoff as shown in Figure 7.5. The effect of secondary systems on major floods is small since most of the runoff is overland and not through the overtaxed secondary system.

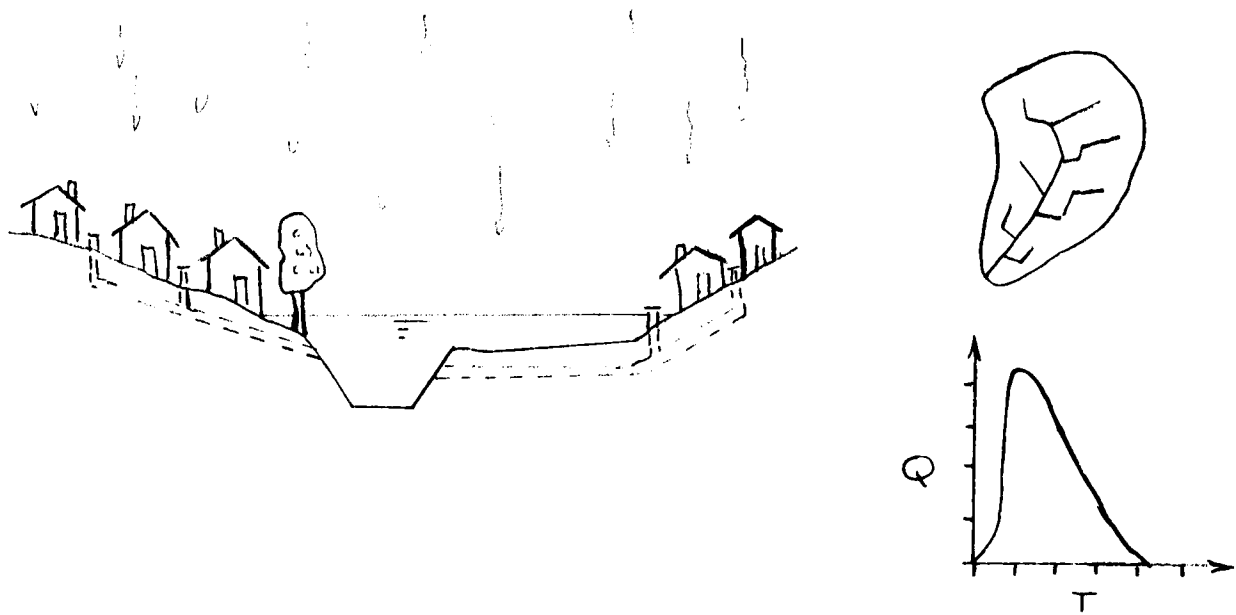


Figure 7.5 DRAINAGE SYSTEM RESPONSE

Reduction of Natural Storage: The reduction of natural storage by landfills, levees, or flood walls may significantly increase flood heights. The effects of flood hydrographs translating throughout the watershed with extensive reduction in vally storage will be increases in peak discharges and consequently flood heights as shown in Figure 7.6.

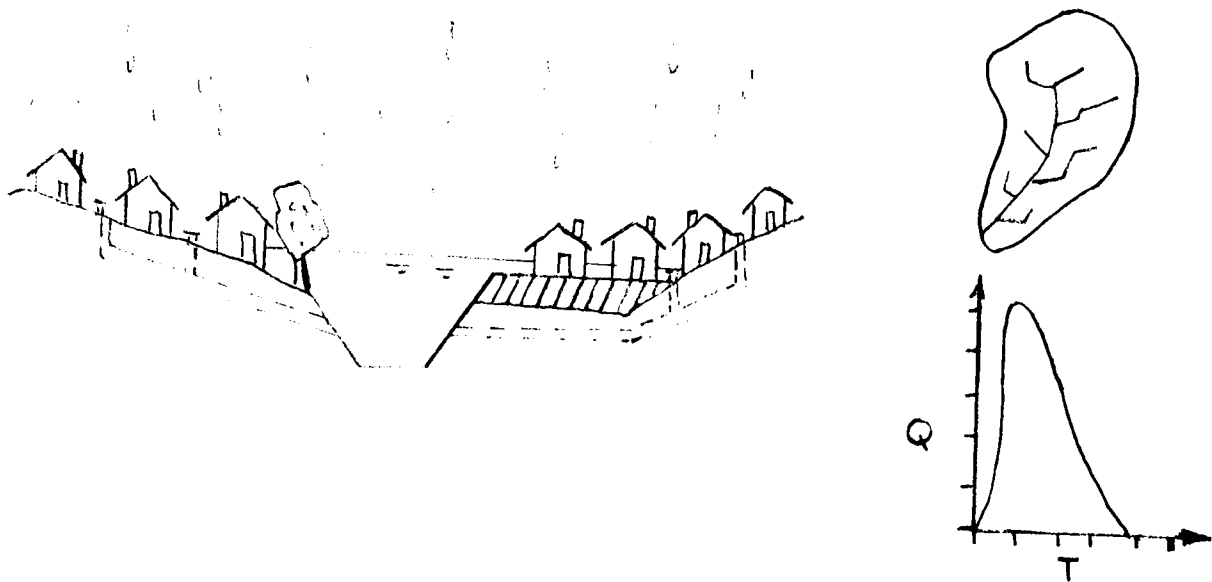


Figure 7.6 STORAGE REDUCTION IMPACT

## Impact of Urbanization

The relative effect of urbanization depends on the original characteristics of the basin, and the location and extent of the land use changes. For steep watersheds with little natural storage and highly impervious soils, it may have little effect on the hydrograph. Urbanization of small portions of the watershed usually have insignificant effects on the watershed's runoff. Urbanization occurring in the lower reaches of a basin may have a slightly beneficial effect by allowing the flows to pass prior to the major flow's arrival from the upstream reaches of the basin.

Urbanization has a much greater effect on lower and moderate discharges than on higher discharges. The more frequent floods peak discharges may be increased from two to five times whereas lesser frequency flows may be only slightly altered. The reasons urbanization has a lesser effect on very large events are:

- o Depression storage areas are filled
- o Secondary systems become overtaxed resulting in overland flow
- o Much of the flow is overbank and is not affected by the channel modifications

## Evaluation of Urban Runoff

The technique selected for evaluating urban runoff is dependent upon the study objective, availability of information, time and funds, and the technology available for performing the analysis. The study objectives should define the output information needed from the analysis. For example:

<u>Objective</u>	<u>Probable Information Need</u>
Storm drainage	Peak flow rates for design condition for small areas
"Major" storm drainage	Flow rates and volumes for larger areas for design condition
Flood control	Same as above for range of events

Stormwater quality control	Volumes, rates for all areas for many events
Receiving water quality quality analysis	Volumes, rates for discharge points for selected events

Since few streamflow gages generally exist in locations of interest in urban watersheds, and long-term records must be correlated with changes in urbanization, pertinent recorded streamflow data is almost nonexistent. Therefore, techniques described in Chapter 6, Hydrograph Analysis of Ungaged Watersheds, are commonly used. Their use may be summarized as:

- o Direct Transfer of Data - This technique is not often used in urban areas because of the dissimilarity of physical characteristics of the watershed
- o Simplified Equations (Rational Method) - peak flows
- o Multiple Regression relationships - peak flows
- o Rainfall-runoff models - hydrograph analysis simulations, peak flows, volumes

QUESTIONS  
CHAPTER 7  
HYDROGRAPH ANALYSIS OF URBAN AREAS

1. What changes to a watershed may occur with urbanization?
2. What is the general effect of urbanization on the peak, time to peak, and volume of the hydrograph?
3. Describe the effects of the following urbanization modifications on the annual flood event and a rare major flood event. What are your conclusions as to the overall effect of urbanization on both flood hydrographs?
  - a. Storm sewers (10-year frequency design).
  - b. Impervious surfaces.
  - c. Channel straightening.
  - d. Extensive flood plain fills.
4. Compare the effects of urbanization on the upper portions of a watershed with that of urbanization occurring in the lower portions of the watershed.

DISCUSSION TO QUESTIONS  
CHAPTER 7  
HYDROGRAPH ANALYSIS OF URBAN AREAS

1. Changes that often occur to an urbanizing watershed are an increase in impervious areas, a reduction in depression storage in the system, a reduction in natural flood plain storage and straightening, smoothing, and widening of channels.
2. The general results of urbanization on the hydrograph are quicker and higher peak flows and an increase in overall volume.
3. The effect of urbanization on the annual and rare flood events depending on the modification would be:
  - a. The implementation of a 10-year frequency storm sewer would provide a satisfactory conveyance system for the annual event and would have little effect on the rarer event.
  - b. The increase of impervious surfaces would typically greatly affect the annual event and have little results on the peak discharges of the rare event.
  - c. Channel straightening would probably not change the annual or rare event drastically, but could have significant results on intermediate floods.
  - d. Flood plain fills would not alter the annual flood since it would probably be contained in the banks of the channel. The discharges of the event could be increased due to reduction in natural storage areas.
4. Urbanization in the upper portions of the basin may increase flood hydrograph peaks at the outlet of a watershed since runoff would be greater and quicker. Urbanization of the lower reaches of a watershed may have a slightly beneficial result by allowing the system to partially drain before arrival of the upper watershed runoff.

CHAPTER 8  
FLOOD HYDROGRAPH ROUTING

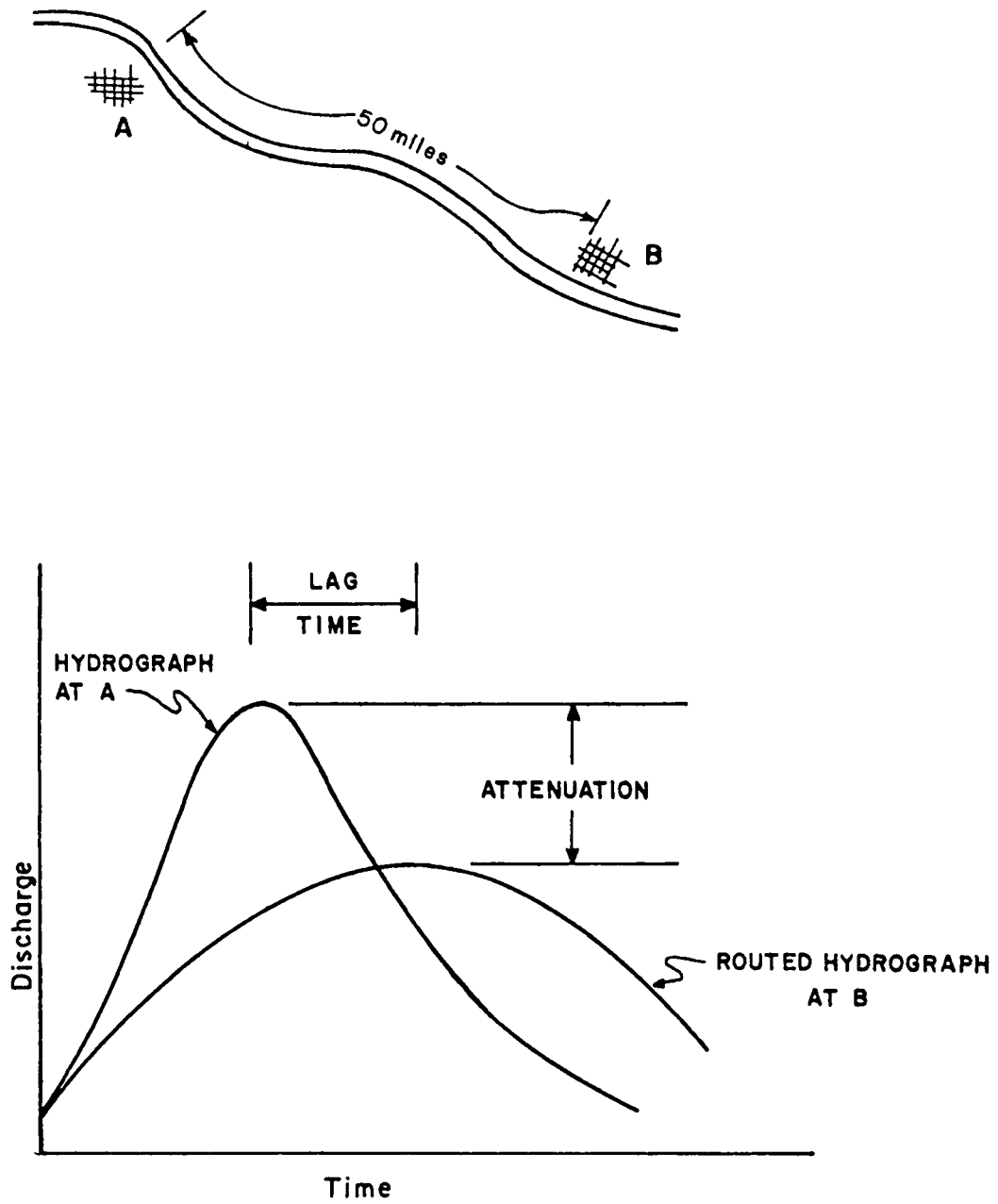
General Concepts

Routing refers to the engineering procedure of tracing the movement of water throughout a hydrologic system, which may be composed of natural streams and lakes or man-made conveyance channels and reservoirs in addition to the natural channels. The basic scientific principles associated with routing are conservation of mass and energy. In the case of water flow in natural systems, the conservation of mass (which includes, volume conservation and time continuity) is normally the dominant factor. Channel routing is concerned with timing and energy conservation, whereas reservoir routing is almost extensively concerned with volume.

The routing of flood hydrographs is required to ascertain the effect of changes within the system on downstream flows and to compute flow at desired ungaged locations throughout the system using known flows (See Figure 8.1). Routing studies are required to:

- o Translate gaged historic events to intermediate locations where gages do not exist
- o Compute streamflow at downstream locations for synthetic (nonhistoric) events
- o Predict the effects of man-made works on downstream flows  
Reservoirs are designed to modify the time distribution of the system's storage and consequently also modify streamflows.  
Channel modifications, levees, floodwalls, etc., also modify the time distribution of system storage and therefore modify streamflow. These effects can be significant and should not be ignored (although they often are).

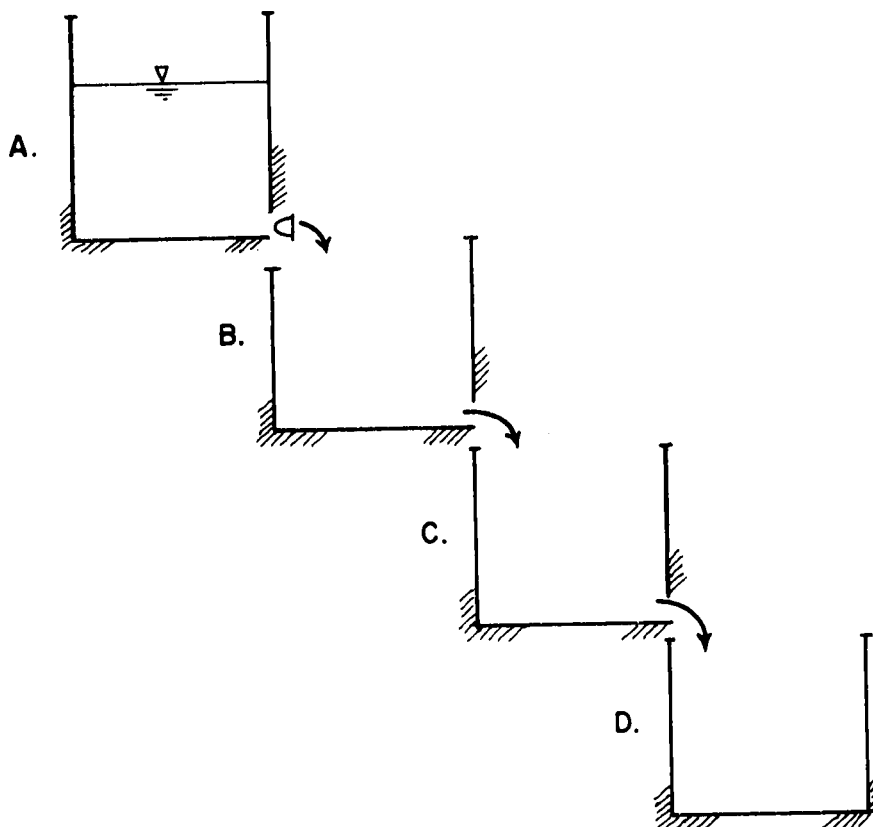




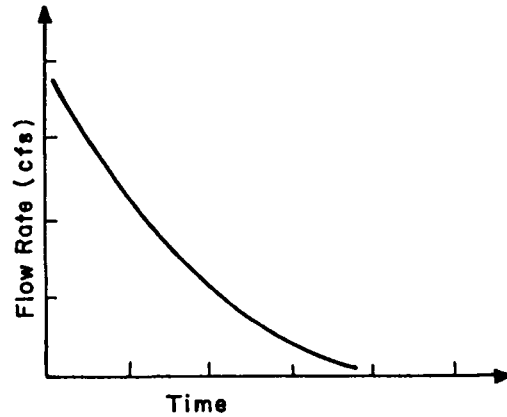
**Figure 8.1 FLOOD HYDROGRAPH ROUTING**

## Routing Concepts

The basic process of routing (in terms of volume conservation and the effects of storage on timing) can be examined by analogy with a series of buckets each with a hole (orifice) to let the water run out. These orifices may be of different sizes. This is illustrated below:

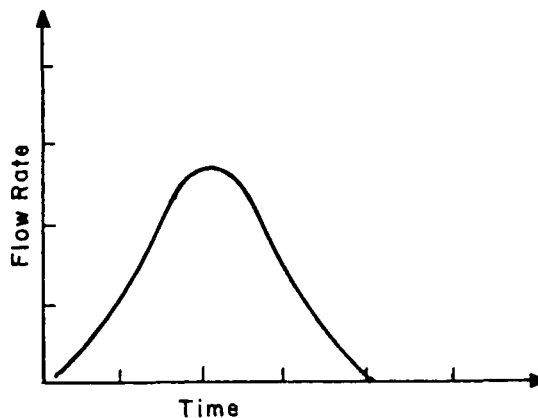


- o Begin by assuming bucket A to be full and its orifice plugged, bucket B empty and its orifice unplugged, bucket C with its orifice unplugged, and bucket D with no outlet.
- o Remove the plug for A and observe that the rate of outflow decreases as the level drops. The time trace of the outflow is illustrated in the following sketch:

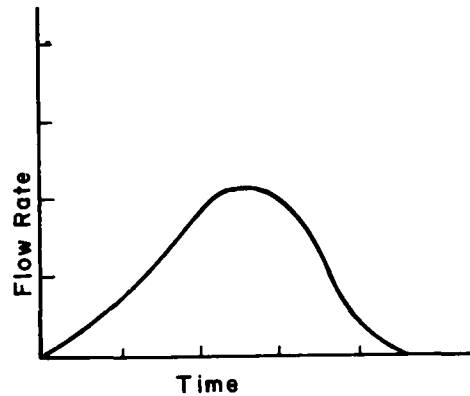


When all the water has run out of A, the volume of water which has passed through the orifice must be equal to that which was initially contained within A. The area beneath the curve in the plot (integrated area) must be this volume.

Now look at bucket B. If the orifice were large enough, flow would pass out of B at essentially the same rate it flows in. Since reservoirs and stream channels have restricted conveyance capacities - the water will not flow out as rapidly as it flows in - there will be temporary storage of some water in B. This is analogous to the passage of a flood hydrograph through a river reach. The outflow from B is shown below; note that the volume (area under the curve in the plot) must be equal to the original volume in A.



A similar temporary-storage phenomena will occur for C (different from B). The outflow from C may be sketched as:



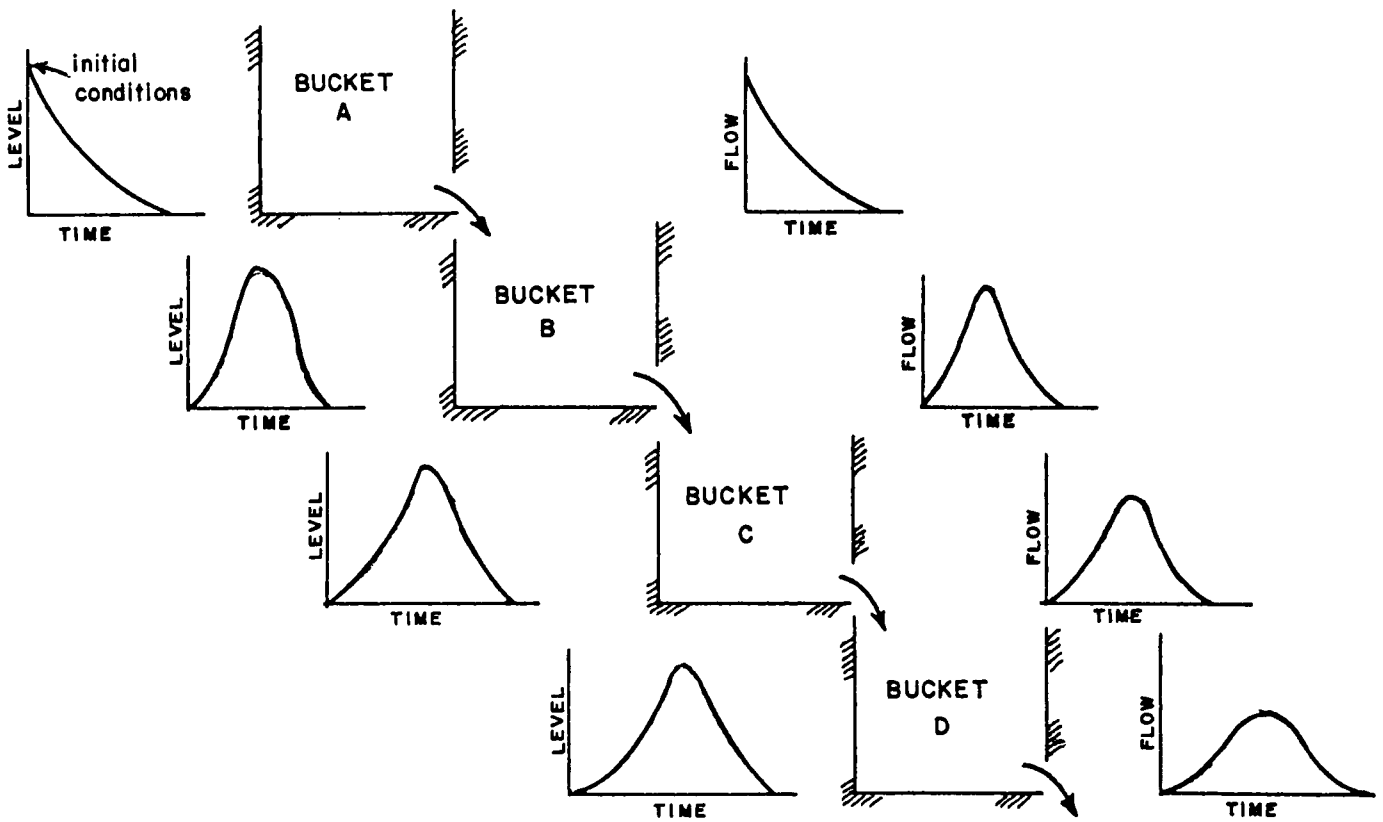
Bucket D catches and retains (orifice is plugged) all the water released from C. It must be equal to the original volume in A. Volume has been conserved, but the time distributions of flow and of volume in each bucket was different - the results of differences in conveyance characteristics (orifice) and the storage relationships (container shape).

Plots of the levels in the bucket are similar to plots of the flow rates. Figure 8.2 shows time traces of water levels and discharges for the system.

The effects of many physical works can be examined by analogy with the buckets. In Figure 8.3 the natural system conditions are shown. Using bucket C, the effect of providing a storage reservoir (control on the orifice) is shown in Figure 8.4, building a levee (reducing the size of the bucket) in Figure 8.5, and modifying the channel conveyance (enlarging the orifice) in Figure 8.6.

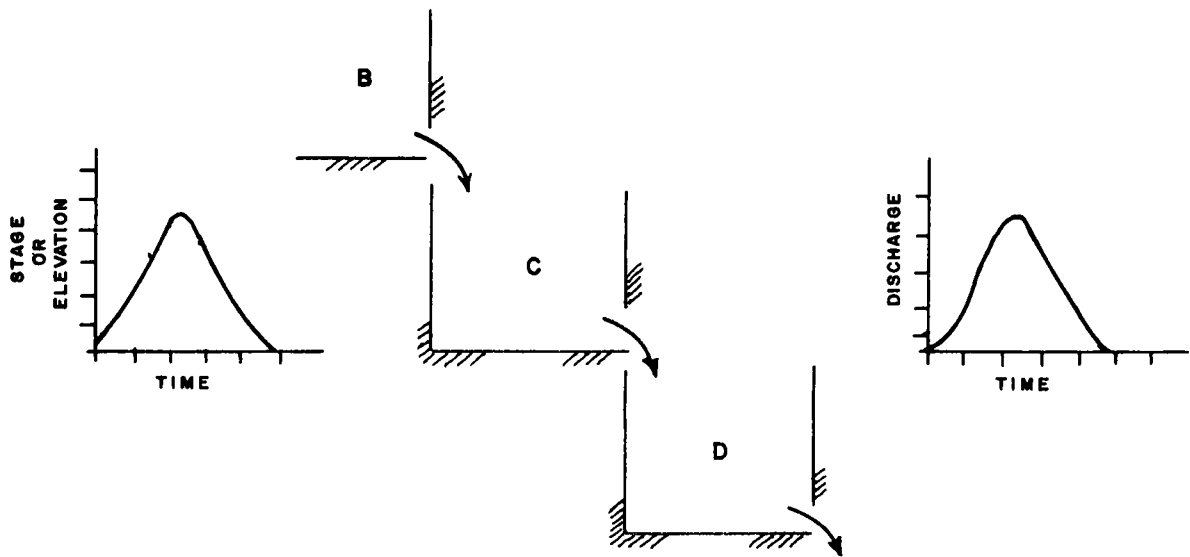
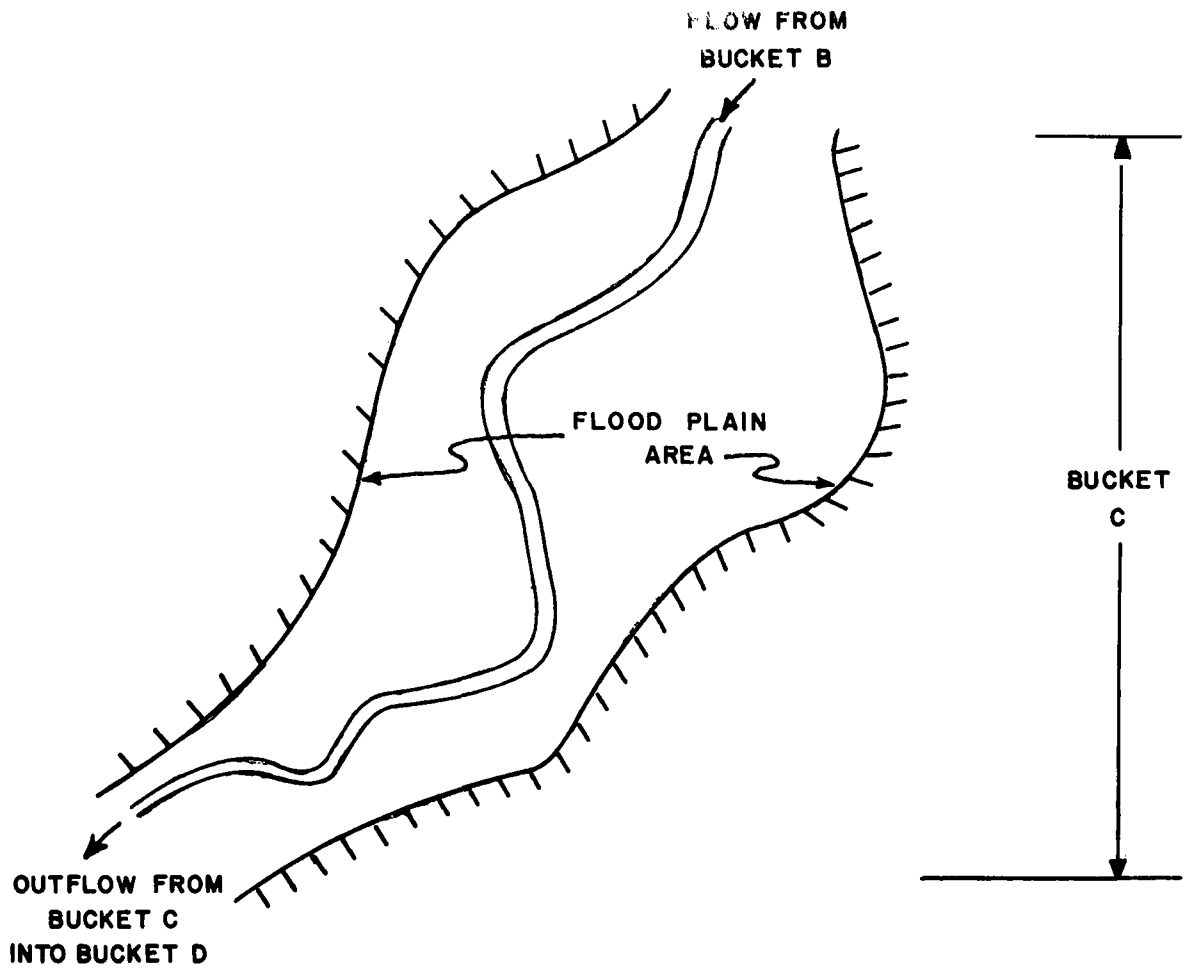
### Routing Techniques

Many techniques have been developed for performing the computations necessary to route flows through reservoirs and stream reaches. Each technique attempts to capture particular aspects of the fundamental concepts involved. Reservoir routing procedures are concerned almost exclusively with

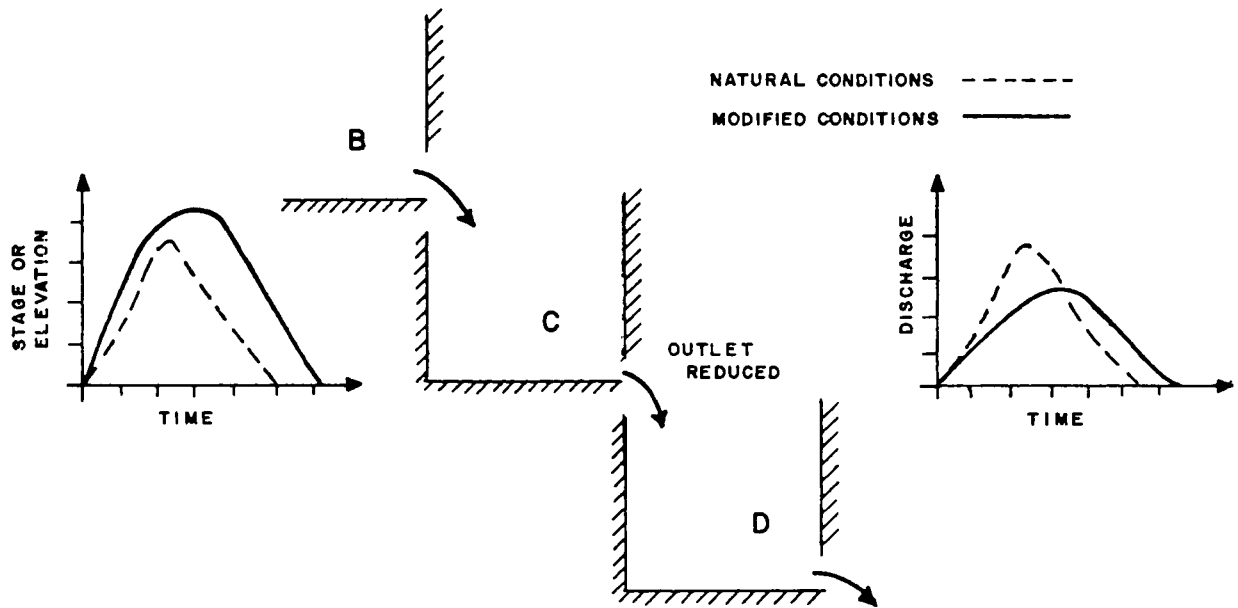
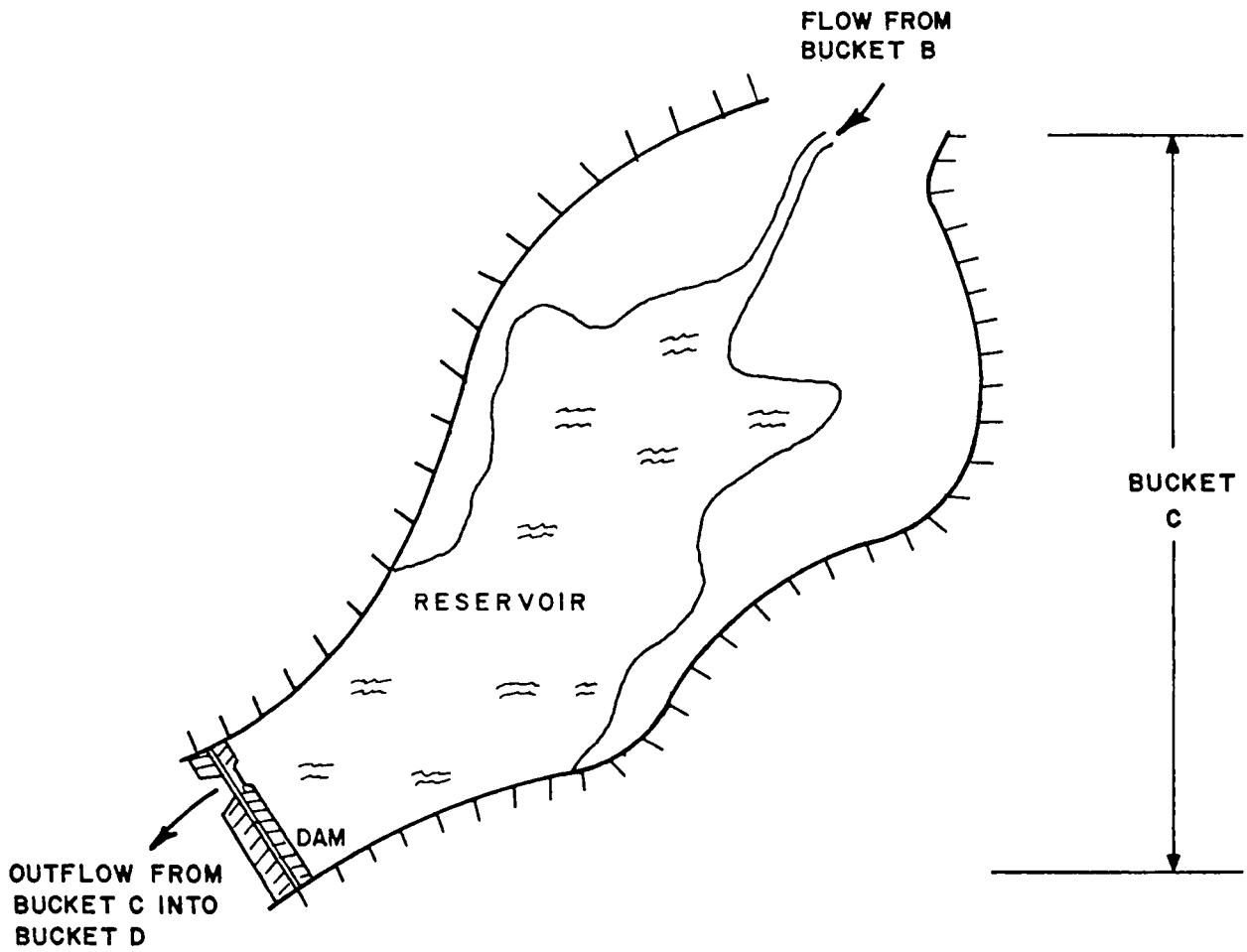


NOTE: The volume of flow passing through each bucket is constant

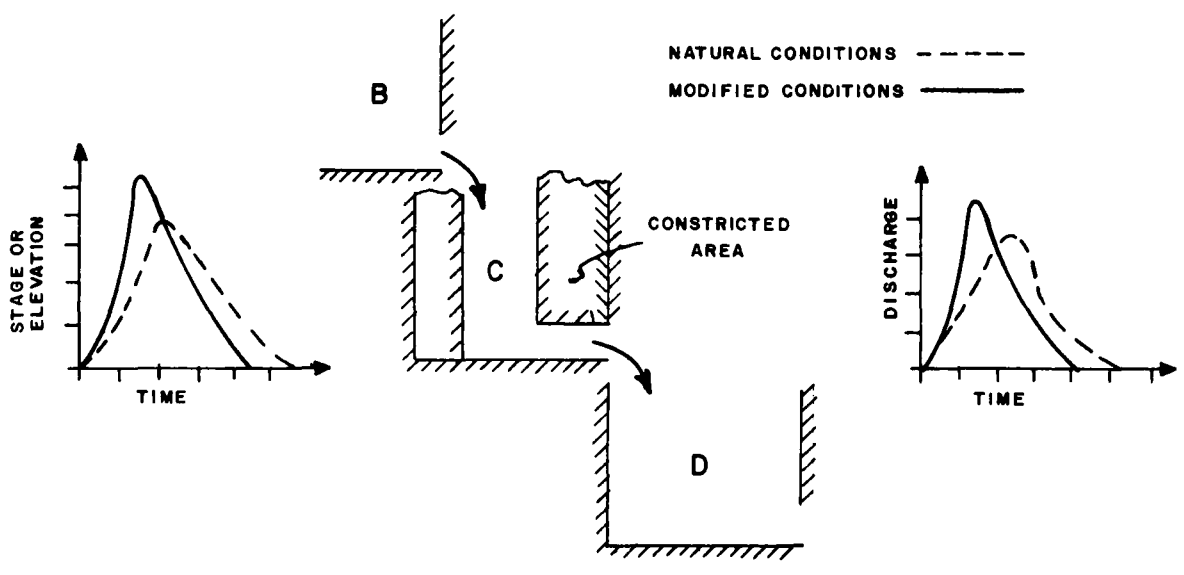
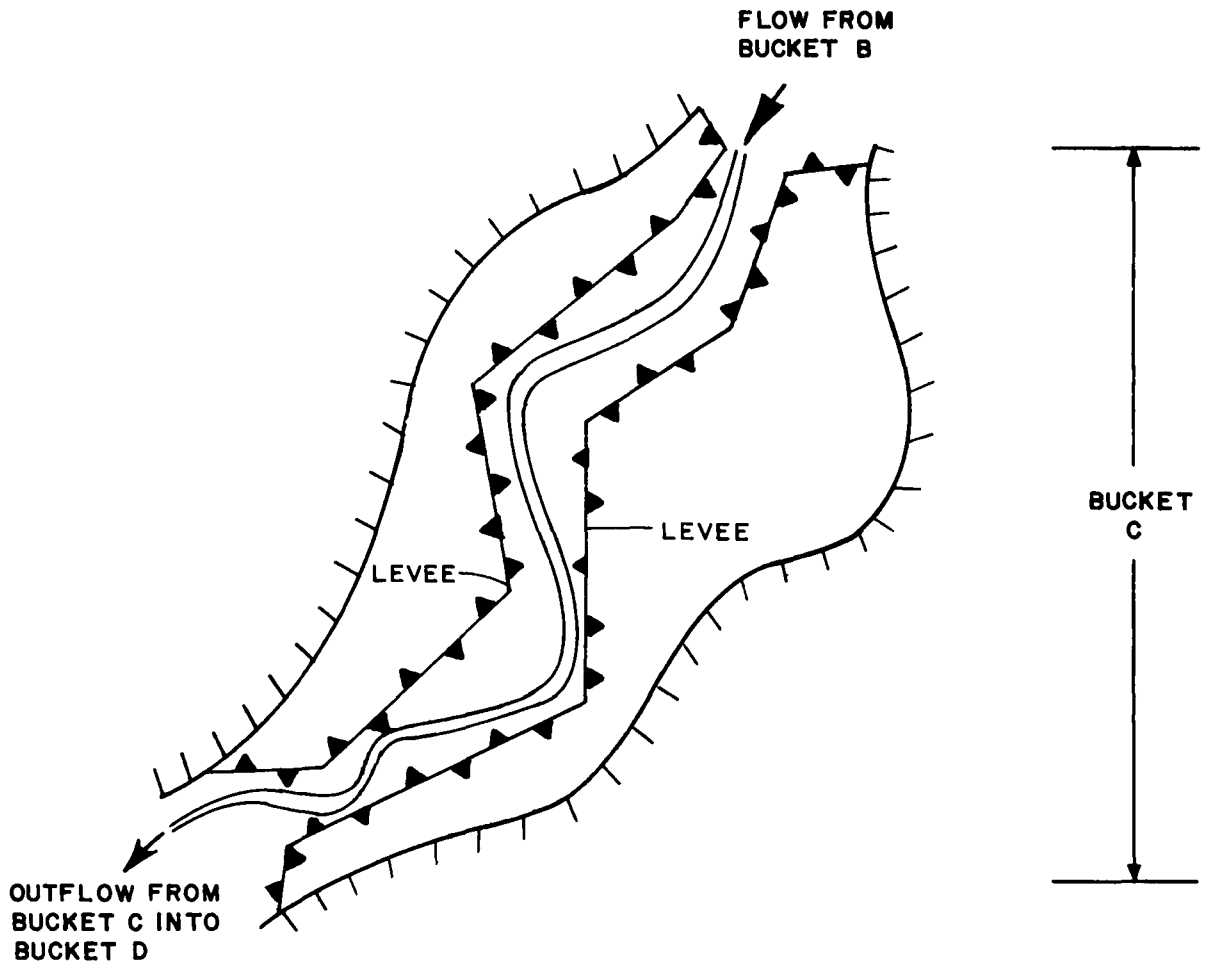
**Figure 8.2 TIME TRACE OF BUCKET LEVELS AND DISCHARGES**



**Figure 8.3 NATURAL SYSTEM CONDITIONS**

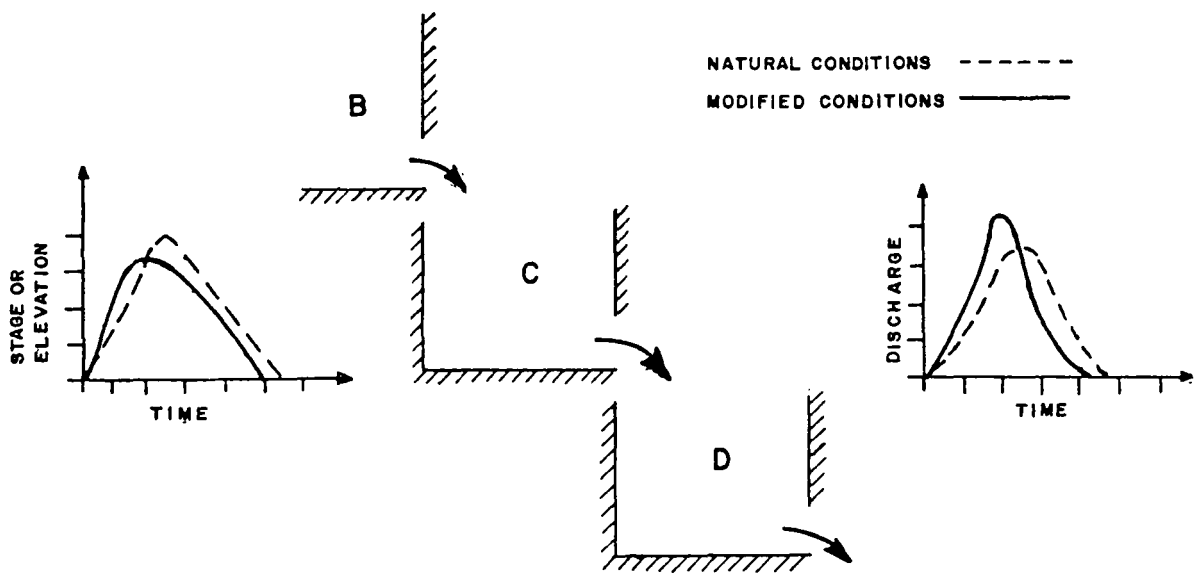
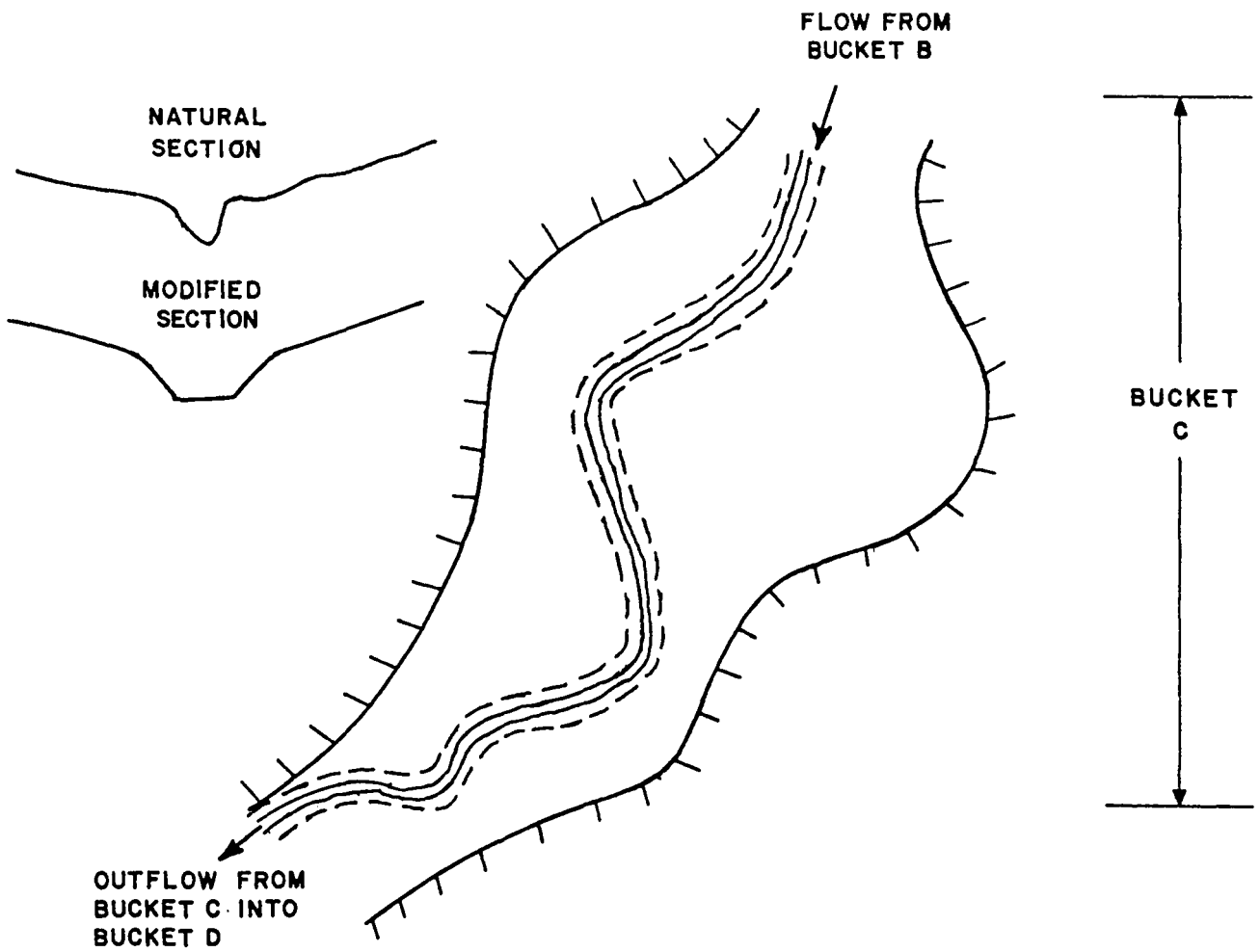


**Figure 8.4 REPRESENTATION OF A RESERVOIR**



**Figure 8.5 REPRESENTATION OF A LEVEE SYSTEM**





**Figure 8.6 REPRESENTATION OF CHANNEL MODIFICATIONS**

volume conservation for the reservoir inflow, outflow, and pool storage. Streamflow routing is concerned with volume, energy, and in some instances, momentum conservation, as well as timing. Reservoir routing procedures, when applied correctly, can be used for streamflow routing. Hydrologic methods refer to those techniques concerned primarily with volume and timing, and hydraulic methods to those techniques concerned with conservation of energy and momentum as well. .

Conservation studies require routing based on long-term accounting of volumes (say 30 years of record). Studies of reservoir yields are usually based on long time intervals of weeks or months. However, hydropower investigations require shorter time intervals, usually of several hours.

Each of the techniques yields reasonable results where the assumptions used in development hold. From the viewpoint of the planner, it is essential that the methods used be compatible with the alternatives to be evaluated, i.e., the method must be responsive to rational adjustments for the proposed alternatives. For example, evaluation of the effects of a channel enlargement on downstream flow cannot rationally be determined by averaging and lagging methods. Application of the Modified Puls Method would be an acceptable alternative. However, it requires developing storage-outflow relations by water surface profile calculations.

A list of the various routing techniques are shown in Table 8.1.

Routing techniques are often referred to as linear or nonlinear.

- o Linear routing methods refer to a group of techniques that are based on an assumption of a straight line relationship between storage and flow in a reach. The most common linear technique is termed the Muskingum Method; other more simplified methods (averaging and lagging) include the Tatum and Straddle-Stagger.
- o Nonlinear methods permit a more general (curved line) relationship between storage and flow, but generally do not include the dynamic effects of inertia (momentum conservation).

Table 8.1  
HYDRAULIC AND HYDROLOGIC ROUTING TECHNIQUES

Abbreviations	Title	Type
V	Unsteady flow using St. Venant Equations	Hydraulic Method
K	Kinematic wave approximation of St. Venant Equations	Hydraulic Method
D	Diffusion approximation of St. Venant Equations	Hydraulic Method
RD	Working R&D	Hydrologic Method
MP	Modified Puls	Hydrologic Method
MU	Muskingham	Hydrologic Method
T	Tatum	Hydrologic Method
SS	Straddle-Stagger	Hydrologic Method
MB	Combination of steady-state backwater computations and Modified Puls or R&D	Hydrologic Method

QUESTIONS  
CHAPTER 8  
FLOOD HYDROGRAPH ROUTING

1. What is the main function of stream routing and reservoir routing?
2. What effect does routing have on the peak, time to peak, and volume of the hydrograph as a flood moves downstream?
3. Using the concepts of the system of buckets presented in this chapter illustrate and describe what modifications (orifice or bucket size) to bucket B correspond to the following land use changes.
  - a. Flood plain fills.
  - b. The development of a large log jam on a stream.

DISCUSSION OF QUESTIONS  
CHAPTER 8  
FLOOD HYDROGRAPH ROUTING

1. The purpose of stream or channel routing is to translate hydrographs from one location to another in the system. Reservoir routing serves the same purpose by translating hydrographs through a reservoir, however, the resulting modifications to the downstream hydrographs are usually more severe.
2. The routing of hydrographs through a desired channel reach or reservoir will result in a lower peak discharge occurring later in time. There is no change in the volume of a hydrograph during the routing process.
3. Using the concepts of the system of buckets the following conditions would occur:
  - a. Flood plain fills - The encroachment into the flood plain by fills would have the same characteristics as the implementation of the levee system illustrated in Figure 8.5. The bucket area would be constricted, thus the modified-condition hydrograph would have a higher peak and would occur earlier.
  - b. Log jam - The development of a large log jam on a stream would be similar to the effects of the reservoir shown in Figure 8.4. The outlet of bucket B would be smaller and the resulting hydrograph would have a lower peak discharge, occurring later in time.

## CHAPTER 9 DESIGN FLOODS

### Types of Design Floods

A design flood is the runoff hydrograph that is selected as a standard against which performance of a facility may be evaluated. A design storm is the precipitation event that results in the design flood's runoff. Design floods typically refer to:

- o Spillway design flood - the flood selected for sizing and operating the spillway of a reservoir
- o Reservoir design flood - the flood selected for sizing and operating the flood control features of a reservoir
- o Project design flood - the flood selected for sizing and operating a project. The project could be a reservoir, levee, interior drainage facility, navigation lock, or even a bridge.

The design flood may be any flood the decision-maker chooses to define as a performance target for a facility. Floods that may be selected are:

- o Probable Maximum Flood - The spillway design flood for reservoirs whose failure would be disastrous to downstream areas. In rare cases, where loss of life and property is great, it may be selected as the project design flood
- o Standard Project Flood - May be the design flood for major reservoirs or local protection projects if it can be economically justified
- o Specific exceedance interval floods such as 10-, 20-, 50-year, etc. These floods are common means of designating "degree of protection" and also of specifying performance standards for storm drainage facilities, and minor local protection projects.
- o Historic floods such as the "Flood of '43," may be used as the design flood on major projects if it exceeds the normal design flood limits and has occurred within memory of local residents.

Concepts of a Design Flood: The concept making use of a design storm or flood is based on the philosophy that one can preselect the performance

criteria one wishes for water resources facilities. It is considered to be dependent upon many factors besides hydrologic factors such as:

- o Economics - must be justified
- o Institutional - we will not build facilities that will not protect against the design flood (N-year event)
- o Political - must be accepted by interested publics, etc.
- o Environmental
- o Social

The basic traditional Corps philosophy has been that major flood control works should have Standard Project Flood protection if it can be justified. However, the more recent concepts and policies are tending to be less based on design storms and floods than in examining the performance of a number of systems and for a wide range of storm and flood events. The system is selected from this information rather than a storm being selected and the facilities following. Many other considerations are emphasized in planning the facilities rather than focusing on just the design-flood event. Alternatives to preselection of a design flood are period-of-record analysis and analysis of a range of events to develop "average" evaluations.

FLUVIAL HYDRAULICS



CHAPTER 10  
INTRODUCTION TO FLUVIAL HYDRAULICS

General

Fluvial hydraulics is the technical subject area concerned with the flow of water in natural river and streams. For the purpose of technical analysis, a conceptual distinction in the hydrologic system between the 'overland flow' component and the 'channel flow' component is useful. In addition, a further distinction is made between technical analysis related to computing flow rates by aggregating hydrographs and accounting for natural stream storage (referred to as routing elsewhere in this manual) and the technical analysis related to determination of stage (water surface elevations) from flow which is generally referred to as hydraulics. Fluvial hydraulics, therefore, has as its main focus the estimation of stage for flow rates of interest in natural channels.

If it were possible, one would simply measure the flow rate for a range of elevations at all locations of interest and use the relationship (a rating curve) for subsequent elevation determinations. Because this is not usually possible, analytic computation methods are normally employed. Computation methods which assume fixed channel boundaries come under "rigid boundary hydraulics" and those accounting for the mobile nature of the streambed as "Mobil Boundary Hydraulics".

Geomorphology

Natural streams have acquired their present form from long-term processes involving land surface erosion, stream channel incisement, and streamflow. Streams, in fact, are either in a natural equilibrium with the determining factors, or are slowly adjusting toward an equilibrium condition. Disregarding long-term climatic and geologic changes, the factors involved in determining the equilibrium are 1) a streams capability to transport sediment; 2) the particle sizes of sediment; and 3) the available supply of sediment. Streams are continually adjusting themselves toward equilibrium so that when natural events (such as forest fires) or human activities (such as

engineering works) alter one of the factors, a stream begins to adjust to accommodate the changed conditions. In many instances, the adjustments are of significance and must be directly accounted for in studies (such as long-term increases in river stage due to sediment deposition), and, in many others, the changes are not important. Because of this latter situation (small potential adjustments) and the overall complexity of considering the effects of change in all situations, there has developed two directions of technical analysis, 1) mobile and 2) rigid boundary hydraulics.

### Mobile Boundary Hydraulics

The mobile boundary view of natural stream hydraulics recognizes that there is a changing relationship between streamflow and channel geometry that is a complex function of sediment supply, transport potential and grain size. This technical analysis viewpoint is generally referred to as "sediment transport analysis". Technology for mobile boundary hydraulics continues to be under development and is presently at a much lower level than rigid boundary hydraulics. Because of the complex specialty nature of the analysis, widespread capability to perform studies is generally not available. This general subject will be discussed in more detail in Chapter 15.

### Rigid Boundary Hydraulics

The rigid boundary view bases the perceptions and analysis of natural streams on the idea that, for a specific analysis, the stream geometry can be considered as fixed (rigid) and, therefore, one can concentrate upon the physics of the flow field. Virtually all water surface profile determinations, such as for flood insurance studies, are based on rigid boundary hydraulic concepts. The governing principles used in analysis are derived from well established laws of physics, and the analytical techniques and tools are highly developed. Conservation of energy (continuous accounting of energy additions to flow e.g., elevation drop, and energy extractions from flow e.g., "head losses") is the dominant concept and is highly developed conceptually and analytically. Chapters 11, 12 and 13 discuss the general concepts involved and relate them to analysis needs and important concerns during planning studies.

## Unsteady Flow

The literal meaning of unsteady flow is flow that changes with time. The transient or unsteady nature of flow is acknowledged since streamflow is seldom constant over any significant period of time. "Unsteady" flow as used by the profession generally refers to a broader classification of changing flow than just flood routing. Changes are sufficiently rapid such that inertial forces are of importance in such instances as the sudden release or stoppage of flow.

It is common practice by hydraulic engineers to perform simplified unsteady flow analysis (termed flood routing) to determine the peak flows at various points downstream, and then to perform steady flow water profile analysis to determine elevations corresponding to the peak flow rates.

Chapter 14 will introduce the notion of inertia, discuss the basic principles involved, and describe instances where this specialized type of analysis is important.

## Planning Interface

Fluvial hydraulics is an area of technical analysis that is required to determine water surface elevation information (as contrasted with peak flow information) and, in certain instances, sediment volumes that are needed in many water resources management studies. Fluvial hydraulic computations are required to provide the following types of information.

- o Flood Control
  - Flood elevations and depths
  - Levee heights
  - Rights-of-way limits
  - Sizing of channel works
  
- o Water Supply
  - Diversion elevations
  - Sizing conveyance canals

- o Navigation
  - Maximum/minimum flow depths
  - Annual maintenance dredging requirement
  
- o Hydropower
  - Powerhouse tailwater elevations

In some studies, fluvial hydraulics might dominate the technical analysis, such as hydrologic studies for extensive channel modification projects, while in others, such as water supply, fluvial hydraulics might play a minor role. The manpower and time resources that can easily be consumed in studies of this type demand that planners be at least casually familiar with the basic principles and fairly specific as to the scope and detail of analysis required to meet identified planning objectives.

CHAPTER 11  
STEADY FLOW RIGID BOUNDARY HYDRAULICS

Introduction

The flow rate in natural streams varies in time, the channel boundaries do not remain rigid but distort with the passage of flood events, and the energy losses and other dominating flow phenomena are complex and only partially understood. One can observe most of the complexities of natural streamflow by standing on a stream bank and observing flow as it passes. One will note that the channel is apparently irregular; it is narrower at some points than others. Surface eddies are visible, and it can be observed that the flow velocity along the boundaries is certainly much different than the flow velocity in the center of the channel. Turbulence seems to be generated at all discontinuities in the flow and at all obstructions. White water will be noted here and there, and a variety of surface wave patterns will be evident. If one watches the stream bank long enough, the water level will be observed to fluctuate and the bank may cave or slough periodically.

It has been the practice of the profession to considerably simplify this view of the flow process so that reasonably systematic analysis of the complex phenomena is possible. In order to reduce the phenomena observed to a manageable technical task, the following series of simplifying assumptions are useful.

- o Steady flow - the flow rate is taken as fixed so that the water level does not fluctuate with time (in the span of interest)
- o Rigid boundary - the cross section is stable in geometric shape (for the time period of interest)
- o One dimensional - the water surface elevation across the channel is horizontal and the flow velocity is in a single direction.
- o Constant fluid properties - the sediment content of the flow does not alter the fluid properties and governing equations.

Assuming these assumptions are reasonable, and in many instances these assumptions are in fact completely satisfactory, the scientific principles

that apply to the determination of the water surface elevations and energy losses are very well developed and can be derived from Newton's laws. The ability to found the analysis on a firm principle of physics is important since it allows extrapolation with more confidence to unmeasured conditions.

Evaluation of flow in open channels is dominated almost entirely by analysis of energy conservation, and to a lesser extent by the determination of flow continuity.

### Continuity

Continuity is the engineering principle which states that mass (stream flow volume) is conserved. Mass conservation in a volumetric sense would mean that for a given reach of the stream, the amount of volume passing at one point will also pass another provided that changes in storage between the points are properly accounted for. In water surface profile and river hydraulic determinations, the governing statement of the principle of continuity is:

$$Q = AxV$$

where

$Q$  = volumetric flow rate in ft.<sup>3</sup>/sec.

$A$  = cross sectional area in ft.<sup>2</sup>

$V$  = mean flow velocity in ft./sec.

The equation states that the volumetric flow rate  $Q$  is equal to the product of the velocity of flow and the area through which the flow is passing. Although the statement of continuity can be viewed as quite simple, an important basic understanding of flow can be derived from this simple relationship. For example, suppose 10,000 cfs were flowing at a location where the flow area is 1,000 sq. ft. The mean velocity can be computed as 10 feet per second. If the flow now is increased to 15,000 cfs, what must change? The equation says one ( $A$  or  $V$ ) or both must increase. Do we know which? Without further information we cannot tell, but we suspect that the

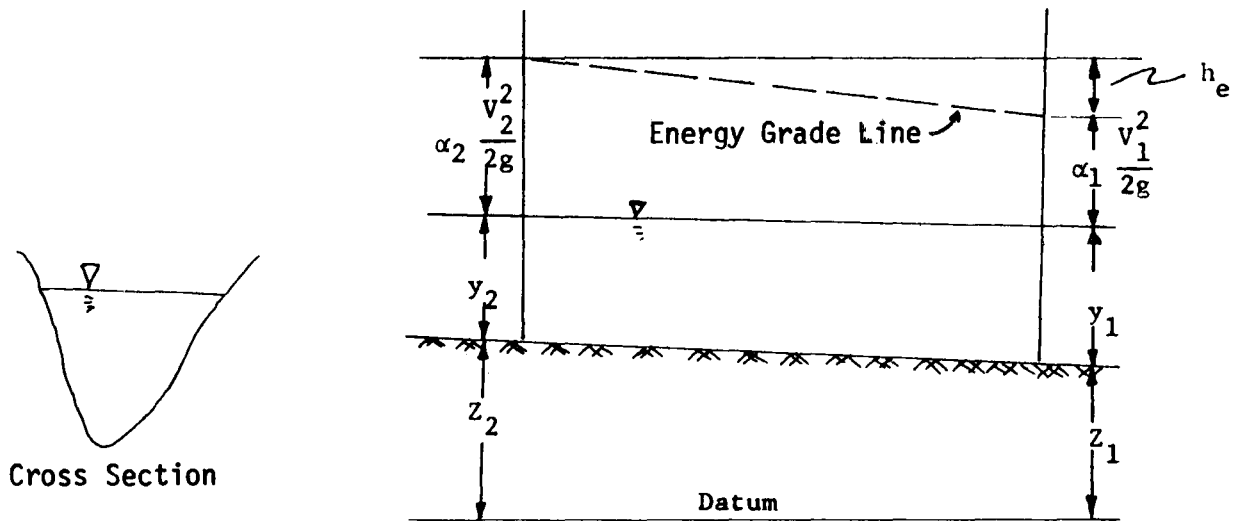
velocity will not increase drastically (a pretty fair assumption) so that the flow area (A) will probably increase to a little less than 1,500 sq. ft. and provide us with a means for estimating the new flow depth if we know the flow geometry. Other similar observations based on changing velocity and changing cross section area can provide some insight into flow within stream channels. One must be careful, however, to not consider the continuity relationships alone but integrate the conclusions with full consideration of conservation of energy as well.

### Conservation of Energy

Energy conservation, stated in a scientific principle, says that in proceeding from one point in a stream system to another, system energy must be continuously accounted for. The mathematical statement of energy conservation is called the Bernoulli equation and is: the sum of the kinetic energy (due to motion) plus the potential energy (due to height) at a location is equal to the sum of the kinetic plus potential energies at another location plus or minus the energy additions or subtractions from the system. Figure 11.1 defines the statement of energy conservation.

A few definitions need mentioning so that the nomenclature that is common among hydraulic engineers can be used in discussions by planners. The sum of the depth plus the kinetic energy (which is termed the velocity head) is defined as the "specific energy" at a given point. The specific energy, when added to the elevation of the channel invert is called the "total head" and in the definition sketch, Figure 11.1, the total head at a point is defined as H. An imaginary line tracing the total head linearly along the channel has been given the label the "total energy line" or at times the "energy grade line".

There is considerable difference between viewing the energy conservation principle as it occurs in a closed pipeline system and as it occurs in an open channel. The key difference is that open channels have another degree of freedom in that the water surface can locate itself with respect to the energy content of the fluid. In a pipeline, if one introduces energy loss at a point, all locations upstream from that point will encounter an increase in



$$z_2 + y_2 + \alpha_2 \frac{v_2^2}{2g} = z_1 + y_1 + \alpha_1 \frac{v_1^2}{2g} + h_e$$

$$\text{Let } H = z + y + \alpha \frac{v^2}{2g}$$

$$H_2 = H_1 + h_e$$

where

$z+y$  = water surface elevation in ft.

$\alpha \frac{v^2}{2g}$  = velocity head in ft.

$h_e$  = energy loss in ft.

$H$  = total head in ft.

**Figure 11.1 OPEN CHANNEL ENERGY RELATIONSHIPS**



pressure that is a result of the energy loss. In an open channel flow situation, this is not the case. For example, if an obstruction is placed in the flow and generates an energy loss ( $h_e$  in Figure 11.1) there is some distance upstream where this energy loss is no longer reflected in the position of the total energy line, and thus the flow depth at that distance is unaffected. The flow conditions will adjust to the local increase in energy loss by an increase in water level upstream. This will allow the flow to gain the energy required to overcome the energy loss, but the increase will gradually decrease in the upstream direction. It is this complication, the freedom in the location of the water surface, that makes open channel hydraulics both a complicated and interesting technical subject.

At this point, another simplification will be introduced so that some basic principles can be discussed in simple terms that will relate quite nicely to the more complicated natural situation: the notion of a prismatic channel. Prismatic refers to a situation in which cross section shape and bottom slope remain constant through the reach of interest. Assuming a prismatic channel and observing the equation and definition sketch previously discussed, one would note the following: the flow depth and velocity head would remain constant between the two locations; the total energy line and the water surface would parallel the channel bottom; and a flow condition that is termed "uniform flow" would occur. In the case of uniform flow, energy would be consumed by losses at exactly the same rate as it would be provided by the drop in channel bottom. It should be noted that natural and other open channels gain their energy from gravity (the change in ground elevation), consume energy in boundary friction, and impact losses from obstacles. With the introduction of the prismatic channel concept, one may speak of classifying flow in terms of profile types and energy levels.

### Flow Classifications

The observation of major distinctions in the character of flow is essential for analysis of flow conditions and an understanding of the nature of flow. The analysis framework has already been classified as steady flow. Further distinction is needed between the two concepts "supercritical" and "subcritical" flow. These terms relate to a theoretical conception of the

energy state of flow. In a practical sense, it can be said that supercritical flow is occurring if the flow velocity is more rapid than the velocity of a small surface wave as may be caused by throwing a rock into the stream. Flow at velocities that are less than the speed of this surface disturbance would result in flow conditions called subcritical. The nature of flow conditions and profiles are quite different between these two situations. In the large majority of flow situations in natural channels, flow exists in a subcritical state. Flow could exist in a supercritical state in man-made channels such as concrete lined chutes and perhaps in very steep mountain streams.

A significant aspect related to flow classification is that the flow profile cannot cross the critical condition (transition between subcritical and supercritical) without a very specific and definable set of conditions occurring. For example, to pass from supercritical flow to subcritical flow, a phenomenon termed a "hydraulic jump" (or as might be observed in a steep mountain channel a "standing wave") accompanied by considerable turbulence would have to occur. These conditions naturally generate tremendous energy losses and greatly complicated flow pattern.

Another classification of flow results from the distinction between "varied flow" and "uniform flow". Uniform flow as we stated previously characteristically occurs in prismatic channels and is a useful reference point since all flow given sufficient distance over which it may occur would tend toward the uniform flow condition. On the other hand, all flow other than that classified as uniform is classified as "varied" in which the depths and velocities vary along the stream channels. Varied flow can occur when the flow is interrupted, such as by bridges, or when the flow field changes, such as by a change in flow rate or change in channel geometry. Within the varied flow definition, "gradually varied" flow refers to the normal situation that is observed in nature where there is a gradual change in depth and velocity along the channel. In this instance, the general energy equation that was defined previously and the general notions related to it continue to apply. The other category of varied flow is termed "rapidly varied" flow, and it is the flow condition that occurs in the vicinity of obstacles such as within the opening of bridges or other features that

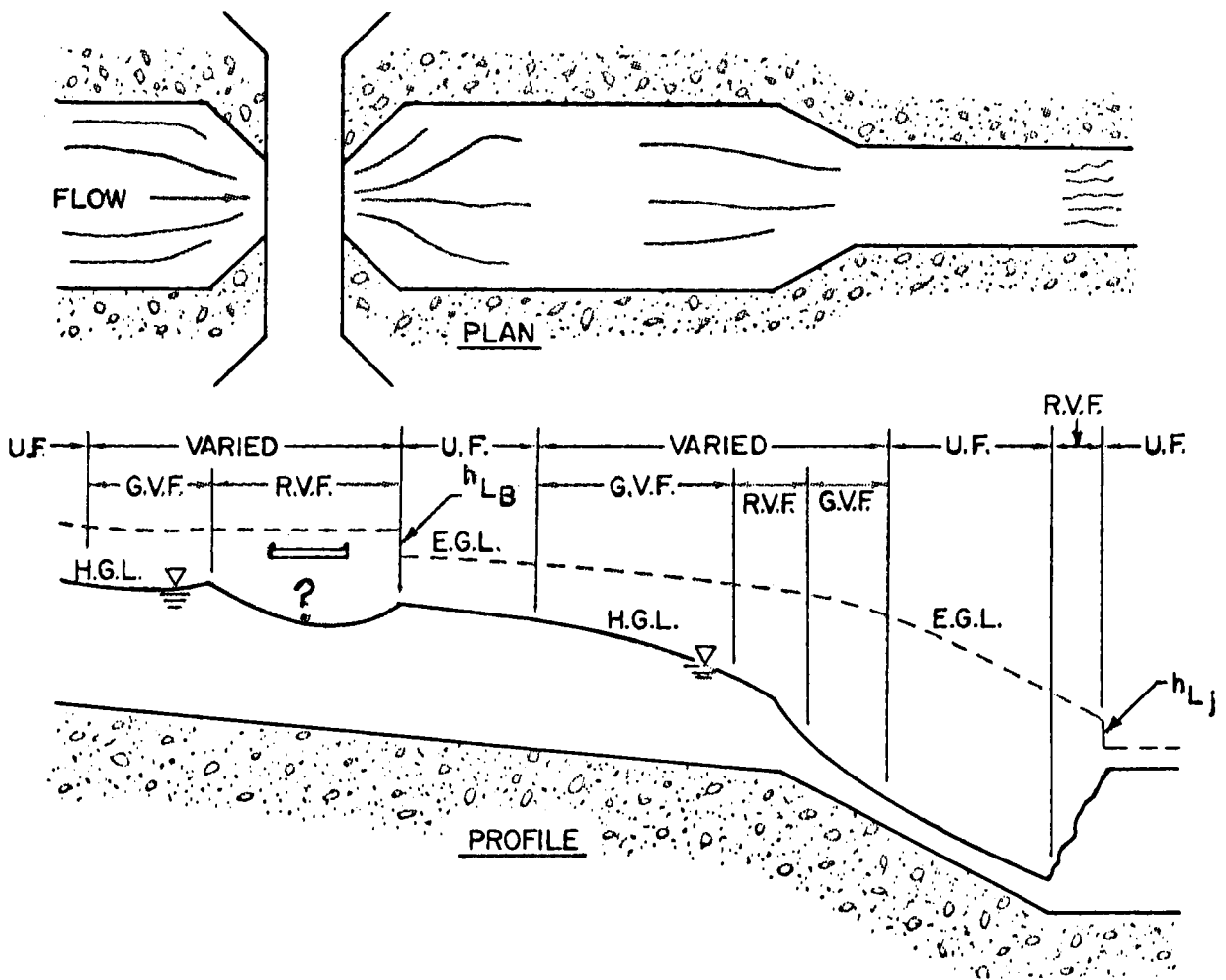
greatly constrict the flow. Rapidly varied flow occurs when the pressure that is exerted within the flow field is nonhydrostatic, meaning that if one were to place a pressure measuring device within the flow field it would not reflect pressure as being simply a straight forward relationship with depth. Figure 11.2 provides an overview of the classifications of the flow in the "varied" categories and also illustrates the conditions whereby critical flow can occur.

It should be once again emphasized, however, that in natural streams, the dominant flow condition is subcritical and in the absence of constructing structures the flow may be assumed to be gradually varied. The classic term "backwater" that is often referred to relates to the condition in which the water surface elevation is raised above the normal condition by a downstream obstruction which creates a higher water level or an energy loss. In the above sketch the condition occurring immediately upstream of the bridge is the "backwater" condition.

The specific reaction or water surface profile change that results from management works such as levees, bridges, and channel improvements is dependent upon the class and type of flow. Conclusions drawn from placing control measures within supercritical flow would not apply for the placement of the same controls in a subcritical flow situation. Some general notions related to changes in water surface elevation that might occur can be obtained from observing the sketch and studying similar situations for man-made management works. Chapter 13 contains a more detailed description of water surface profile types and the changes that can occur in the vicinity of management works.

### Relationship to Natural Channels

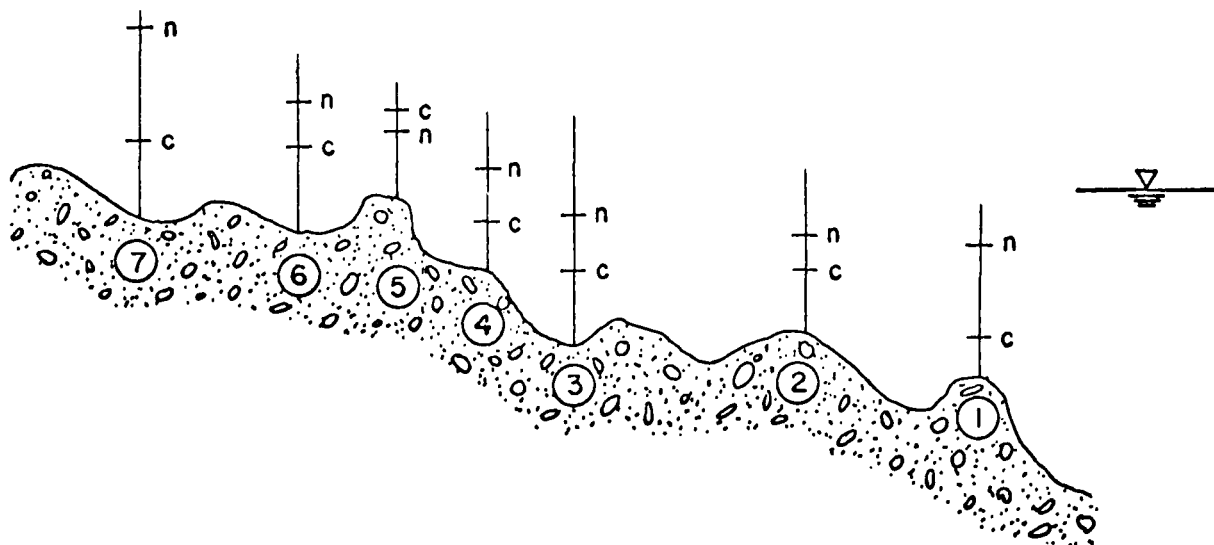
The primary conceptual change in moving from the study of prismatic channel hydraulics to natural streams hydraulics is caused by variations in cross sections and the varying rate of drop of the channel invert. The sketch below illustrates the conditions that occur in a natural channel. Figure 11.3 is a profile view of a natural stream. The "n" refers to the uniform flow depth called "normal depth" for a given discharge and the "c"



The abbreviations in the previous figure are:

- U.F. = Uniform flow
- G.V.F. = Gradually Varied Flow
- R.V.F. = Rapidly Varied Flow
- E.G.L. = Energy Grade Line
- $h_{LB}$  = Head loss due to bridge
- H.G.L. = Hydraulic Grade Line
- $h_{Lj}$  = Head loss due to jump

**Figure 11.2 FLOW CLASSIFICATIONS**



**Figure 11.3 NATURAL STREAM PROFILE**

refers to critical depth for the same given discharge. Note that they have a varying relationship to one another along the profile.

The significant point is that in nature, there is no such condition as uniform flow. There never exists a complete balance (in theoretical sense) between the rate in which energy is being consumed and the rate at which it is being added by drop in the channel bottom. However, over a given distance the rise and fall in the channel bottom and the fluctuations in cross section areas will give rise to conditions that approximate a uniform flow condition so that the notion that flow is always attempting to adjust to a "normal" situation can generally be applied. For instance, in the above sketch it could be possible that the flow profile would be similar to a gradually varied flow profile that is increasing in depth in a downstream direction, similar to what was termed "backwater" in the case of the prismatic channel upstream of the bridge in a previous sketch. The changing relationship between the critical depth and normal depth along the channel gives rise to a number of computational difficulties in defining a water surface elevation and also in completely relying upon generalizations as to the behavior of the

profile in a natural channel. The general notions discussed thus far will by and large be valid in the general case, but there must always be a thorough analysis of the energy balance before definite conclusions can be drawn in a particular project situation.

### Energy Loss

The predominant concern of the hydraulic engineer in analysis of the conditions of flow and determination of water surface elevations is the continuous accounting of the energy state of the flow, which is dominated by the determination of "energy losses". Energy losses consist of the loss in energy in the system that is consumed by boundary friction and by internal turbulence generated by discontinuities in the boundaries.

### Friction Loss

Boundary friction generates energy losses by internal fluid shear between water particles moving with respect to each other. Since flow is not moving at the channel boundary, but is moving at some distance away, shear must exist. A number of mathematical equations are in current use that model the friction energy loss phenomenon. All equations basically have the components of a factor that describes the rate of energy loss, a relationship for accounting for boundary roughness, a measure of the amount of boundary that is within contact of the flow, and the flow velocity. The standard that has been used by the profession for many years is the Manning Equation that is defined as:

$$Q = AV = \frac{1.49}{n} AR^{2/3} S_f^{1/2}$$

where

Q = flow rate in cubic feet per second

n = Manning roughness coefficient

A = flow area in square feet

R = hydraulic radius (A/WP) in ft.

WP = wetted perimeter in ft.

$S_f$  = rate of energy loss in ft./ft. due to friction (slope of energy line)

The Manning equation in its usual form shows the computation of the flow rate Q as a function of the boundary roughness, flow area, channel shape, and rate of energy loss. For computation of water surface elevations in the usual case, the equation is solved iteratively to determine the rate of energy loss so that energy may be balanced between adjacent locations. The normal situation is that the downstream water surface elevation is known (elevation is known at a control point) and other elevations are to be determined so that water surface elevation and energy loss are both unknown requiring an interactive solution. The equation is applied conceptually to selected strips along the channel so that account can be taken of the varying nature of boundary and the flow velocity change laterally across the channel.

An example illustrating the nature of the Manning equation when applied to natural streams is contained in Chapter 12.

### Other Energy Losses

The other energy losses that must be accounted for in energy conservation computations are those that occur because of major disturbances in the flow such as those caused by bridges, wing dam constructions, and flood plain fill. The major conceptual components generating energy loss are the contractions of the flow field upstream of the obstruction, the expansion that occurs downstream of the obstruction, and the losses generated by impact with the obstruction itself. A dominate loss that occurs in such structures as bridges results from the expanding portion of flow downstream. It seems that flow can efficiently contract (in terms of energy conservation) but is incapable of expanding without the generation of significant energy losses.

Obstructions in flow generally cause local changes in water surface elevations that are of interest in a planning situation. For example, the introduction of a bridge or, for that matter, an encroached channel condition

at a given point, will generally raise the water surface elevation for some distance above that point. If the flow is subcritical, which is the usual case, the encroachment will not cause any change in water surface elevations downstream. Another situation, in which encroachments along the stream channels change the natural storage and flow rates, is discussed in a previous chapter related to streamflow routing.

### Summary

The flow in natural channels can be analyzed by well founded scientific principles assuming that specific conditions can be imposed, such as steady flow and rigid boundaries. The nature of the response of water surface elevations, flows, and velocities is not mysterious but rather straight forward, and is generally well understood by the practicing profession. The predominant principles that are involved in determining the flow in a specific situation are that of volume, continuity and energy conservation. For energy conservation, the major concern is the analysis of energy losses between locations in the system.



QUESTIONS  
CHAPTER 11  
STEADY FLOW RIGID BOUNDARY HYDRAULICS

1. In a typical natural channel would one expect the water surface elevation to increase if the flow rate were to increase? The water surface to increase if the cross sectional area were decreased? Why?
2. When would an increase in flow rate result in a lower surface elevation?
3. What is the predominant feature that provides energy to flow in natural channels? Discuss the situation that would occur if a bridge were introduced into a natural channel that was experiencing subcritical flow? What would occur upstream and what would the conditions be downstream?
4. What term in the energy equation would the modification of the geometry of a natural channel impact upon? Is this the only term affected?
5. What major notions of river hydraulics are of predominant concern to planners?

DISCUSSION TO QUESTIONS  
CHAPTER 11  
STEADY FLOW RIGID BOUNDARY HYDRAULICS

1. Yes, because the increased flow would occupy a greater flow area; yes, because a decreased cross section area would require compensation by increased depth to maintain the needed flow area.
2. Expect the water surface elevation to increase in virtually every case.
3. The drop in land surface (channel) elevation. Introducing a bridge to the flow would generate increased energy loss. The upstream level would rise for a distance upstream and no change would be induced downstream.
4. Modifying geometry would directly change the velocity head term ( $v^2/2g$ ) which would incidentally affect both the energy loss term and water surface elevation.
5. A question to reflect upon!

## CHAPTER 12

### WATER SURFACE PROFILE COMPUTATION

#### Introduction

The operational conversion of flow rate to water surface elevation is a task performed by the hydraulic engineer. In many hydrologic studies, this task consumes a major proportion of the analytical efforts. The alternatives that are available for conversion of flow rate to water surface elevation range from extrapolation and adjustment of observed high water marks, to the detailed analytical computation of water surface profiles, referred to by many as "backwater computations". Computation methodologies range from techniques that are very simple (extensions of prismatic concepts) to the more complete natural stream standard step backwater analysis which is normally performed in Corps of Engineers studies. The subject to be discussed in this chapter is the latter which comprises the operational application of the principles described in the previous chapter. The framework for the analysis is to determine water surface elevation profiles for specific flow rates at specific points, where the flow rates have been developed by hydrologic analysis.

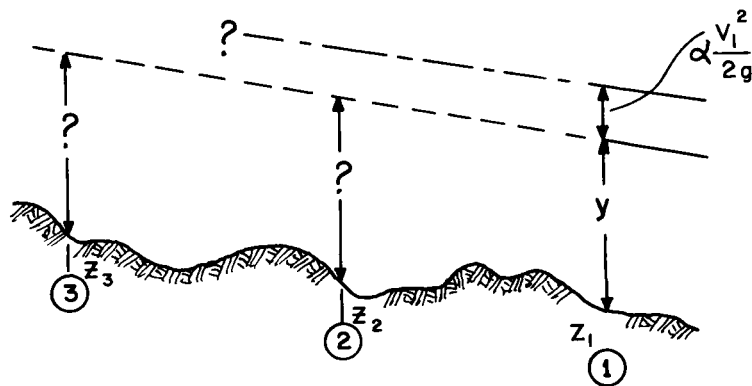
#### General Process

The overall process includes preparation work and actual computations. The preparation work consists of:

1. Assembly of flow and geometric data from hydrologic computations and field surveys.
2. Estimation of energy loss calibration coefficients. These coefficients may be determined by trial computations designed to reproduce observed streamflow high water marks. The coefficients are adjusted until an observed profile is matched, which is the desired condition. In the absence of observed data, the coefficients may be derived from experience, from handbooks supplemented by field observations, or perhaps transferred from similar stream reaches with known coefficients.

The production aspect involves the computation of the desired water surface profile. The production phase is usually a small part of the overall process with a relatively large amount of effort required to assemble and process flow and geometry data and calibrate the resistance coefficients for computations. Once these above items are accomplished, the processing is generally a simple final step requiring only checking for consistency and discontinuities in the computed profile.

The sketch below defines the conditions that may exist for a typical water surface profile determination.



Flow conditions are known or assumed at a location in the stream (location 1), and it is desired to determine the flow conditions (including water surface elevation) at other locations such as locations 2 and 3. The general computational process is as follows:

1. Based on known water surface elevation, compute flow condition and energy level at location 1.
2. Assume water surface elevation at location 2 and compute energy level and flow conditions at location 2.
3. Compute water surface elevation at location 2 using the known conditions at location 1 and the rates of energy loss computed in step 2.

4. Compare the water surface elevation computed in step 3 with the assumed water surface elevation in step 2.
5. Repeat steps 2 through 4 if elevations are not within a tolerable error.

The recursive application of this methodology is performed by continuously stepping from one location in a stream to another. The computations are quite repetitive, the solution techniques are well defined, and the number processing aspect of the process are quite demanding. Therefore, the procedure is a very logical candidate for computerization, and at the present time, virtually all water surface profiles are computed with the aid of the electronic digital computer.

### Example

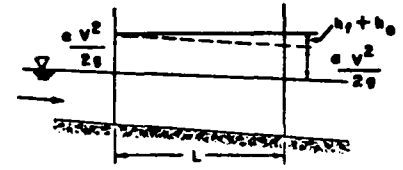
As an aid in bringing together principles and concepts discussed thus far and to provide a bit of the flavor of the numerical operations required to determine water surface elevation profiles in natural channels, the example contained in Table 12.1 will be discussed in some detail. The example requires the computation of the water surface elevation at location 2 (labeled River Mile 1.5) with conditions known at location 1 (labeled River Mile 1.0). Sketches in the lower portion of the figure show the channel geometry for the two locations. Idealized geometry is used to simplify the arithmetic associated with determining the geometric elements.

The initial columns of the table are for recording assumed and computed conditions for the comparisons that were described in the computation process. The table heading labeled  $A$ ,  $R^{2/3}$ , and  $n$  are hydraulic geometry elements required for the computation of the rate of energy loss. The columns labeled  $K$  and  $K$  introduce the concept of conveyance, which is a function of the hydraulic geometry and Manning's  $n$  from the Manning Equation and is a measure of the flow carrying capacity of a portion of the channel. The remainder of the table is designed to cause systematic computations of the energy loss due to friction  $h_f$ , the kinetic energy (defined as  $V^2/2g$ ) and finally expansion and contraction energy losses that will be described

Table 12.1 WATER-SURFACE PROFILE CALCULATIONS

PROJECT: STANDARD STEP EXAMPLE

$q =$  \_\_\_\_\_  
 $c_e = 0.3$        $c_c = 0.1$

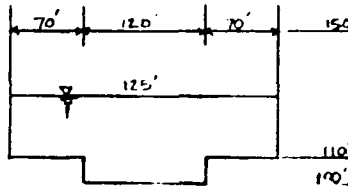


CROSS SECTION NO.	WATER SURFACE ELEVATION		AREA A	HYDRAULIC RADIUS R	R <sup>2/3</sup>	n	10 <sup>3</sup> K	$\bar{K}$	$\bar{S}_f$	L	h <sub>f</sub>	10 <sup>9</sup> K <sup>3</sup> /A <sup>2</sup>	a	v	a v <sup>2</sup> /2g	Δ(a v <sup>2</sup> /2g)	h <sub>o</sub>	Δ(WATER SURFACE ELEVATION)
	ASSUMED	CUMPUTED																
(1)	(2)	(3)	(4)	(5)	(6)	(7)	(8)	(9)	(10)	(11)	(12)	(13)	(14)	(15)	(16)	(17)	(18)	(19)
1.0	125.0		1050	12.35	5.35	0.04	209.0					8.3						
Q = 11,000			3000	21.40	7.70	0.02	1730.0					575.4						
			1050	12.35	5.35	0.04	209.0					8.3						
		TOTAL	5100				2148.0					572.1	1.53	2.16	0.11			
1.5	126.1	125.06	666	9.37	4.41	0.045	97.0					2.05						
Q = 10,500			2426	18.00	6.85	0.025	988.0					163.90						
			666	9.37	4.41	0.045	97.0					2.05						
		TOTAL	3758				1182.0	1665	0.0023	2640	0.10	168.00	1.47	2.79	0.17	-0.06	0.02	+0.06
	125.0	125.04	600	8.6	4.2	0.045	83.0					1.58						
			2300	17.0	6.1	0.025	911.6					144.60						
			600	8.6	4.2	0.045	83.0					1.58						
		TOTAL	3500				1077.6	1612.8	0.0004	2640	0.11	147.76	1.47	3.02	0.20	-0.09	0.02	+0.04

12.4

X-SECTION 1.0

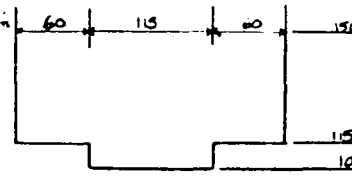
Q = 11,000 cfs  
 $N_{au} = 0.02$   
 $N_{ab} = 0.04$



X-SECTION 1.5

Q = 10,500 cfs  
 $N_{au} = 0.025$   
 $N_{ab} = 0.045$

L = 2640'



(8)  $K = \frac{1.486 AR^{2/3}}{n}$

(9)  $\bar{K} = \frac{K_{upstream} + K_{downstream}}{2}$

(10)  $\bar{S}_f = \left(\frac{\bar{K}}{K}\right)^2$

(12)  $h_f = L \bar{S}_f$

(14)  $a = \frac{(A_T)^2 \sum (K_i^3/A_i^2)}{(K_T)^3}$

where:  
 i = incremental value

T = total value

(15)  $v = Q/A_T$

(17)  $A \left( \frac{v^2}{2g} \right) = \left( n \frac{v^2}{2g} \right)_{downstream} - \left( n \frac{v^2}{2g} \right)_{upstream}$

(18a)  $h_o = C_e \left| \Delta \left( \frac{v^2}{2g} \right) \right|$  for  $\Delta \left( \frac{v^2}{2g} \right) < 0$

(18b)  $h_o = C_c \left| \Delta \left( \frac{v^2}{2g} \right) \right|$  for  $\Delta \left( \frac{v^2}{2g} \right) > 0$

(19)  $\Delta(\text{water surface elevation}) = \Delta \left( \frac{v^2}{2g} \right) + h_f + h_o$

subsequently. Note also the general horizontal layout of information and processing for a subdivision of the channel into three components. This is for the purpose (described in Chapter 11) of including the individual transport characteristics of each element of the cross section so that a more accurate determination of the rate of energy loss and kinetic energy can be made. In many computerized computations, up to 20 subdivisions of the cross section can be defined.

Example Computation: The known water surface elevation at (1) is 125.0 and the flow rate is 11,000 cfs. For an elevation of 125.0 the cross sectional flow area for the 3 elements are 1,050, 3,000, and 1,050 totaling 5,100 sq. ft. The hydraulic radius (R) is similarly computed and raised to the two thirds power (5.35, 7.70 and 5.35). Note that all pertinent mathematical equations are shown at the bottom of the page. The hydraulic elements  $A$ ,  $R^{2/3}$  and  $n$  are then brought together to compute the conveyance for the elements of the cross section (209, 1,730, and 209 totaling 2,148). The distribution of conveyance within a cross section ( $k$  values) are then formed into a relationship for determining the velocity head coefficient ( $\alpha = 1.5$ ) and multiplied times the velocity head to yield the kinetic energy of .11 ft. Known conditions have now been defined.

The first estimate of the water surface elevation at location (2) is assumed to be 126.1. The above process that was required for computing the conditions at location (1) is then repeated for the water surface elevation 126.1. The concluding effort is the computation of the average conveyance  $K$  (1,665), the energy loss due to friction (0.1) and the balance in the energy relationship showing a change in water surface of +.06 feet, (.10 - .06 + .02), the column shown as WS. The computed elevation is thus 125.06 compared to the assumed 126.1, which is not within the tolerance of .05 ft. Another cycle is then repeated for an assumed elevation 125.0 and the computed elevation (125.04) is within the allowable tolerance, and we conclude that the water surface elevation of location (2) is 125.04 feet).

Note that even though the flow is proceeding from left to right in the sketch, that the water surface elevation is almost the same at both locations. How has this occurred? Note that the velocity has increased from

(1) to (2) which means that the flow is slowing down and thus the depth is increasing in a relative sense in the downstream direction. This illustrates the complex interaction accommodated by the energy principle allowing changes in water surface elevation, velocity head, and energy loss to be adjusted for specific flow conditions.

### Data Requirements

The example should bring to mind questions regarding the overall requirement for information to facilitate the detailed computations. The stream reaches to encompass the area of concern and the evaluation conditions (such as encroachments) that are desired, and the flow rates that are of interest need specific definition. The class of the flow must be determined so that computations can proceed systematically. Most computational procedures require that the flow class be defined (either supercritical or subcritical) or computations will cease somewhere during the middle of the process. The initial condition (starting water surface elevation and location) is needed. Other needed data include calibration information (the horizontal distribution of channel roughness at all locations of interest, and the energy loss relationships for all obstructions such as bridges and changes in channel geometry) and finally the geometric data that is required to describe the hydraulic flow field. The geometric data is comprised of channel geometry (cross section data) and flow length between locations of interest. Because of the expense and importance of defining the hydraulic geometry it will be discussed further.

Geometric Data: Detailed cross sectional geometry is required to provide a numerical description of the flow field. The data must describe the river channel and flood plain so that the flow conditions can be modeled. In general, geometric data is required at all locations where significant changes in the hydraulic regime of the stream would occur such as where there is appreciable change in cross sectional area, or an appreciable change in the channel roughness characteristics, or a significant change in channel slope, or where major tributaries intersect. Other locations where cross sections generally should be obtained are:



- o Above, below and within bridges
- o At the head and tail of constricted sections such as levees
- o At all control sections such as gaging stations

It is essential that the flow be described accurately which requires that cross section geometry be taken normal to the flow lines, and not necessarily perpendicular to the main stream channel. Where energy losses are occurring rapidly, such as in urban areas with many bridges and other obstructions, cross sections are required more frequently. Cross section data acquisition is expensive and there are trade-offs between the quality of the computed results and the completeness of the data collection and geometric description of the flow field.

Some specific guidelines that may be of interest (and probably should not be used to hold some hydraulic engineer's hand to the fire) are in Beasley [2]. The guideline is as follows:

"Maximum length between cross sections should not exceed a half mile for wide flood plains and slopes less than 2 feet per mile, 1,800 feet for slopes less than 3 feet per mile and 1,200 feet for slopes greater than 3 feet per mile."

In addition the computations that result will basically dictate the requirements and indicate the degree to which the overall analytical procedure assumptions and analysis techniques are being met. For instance, if the rate of energy loss between adjacent sections changes by more than 100% then the methods used are poor approximations and more cross sections are needed. Also, if the distribution of flow from one location to other changes substantially, such as from 50% within the channel at one cross section to only 10% within the channel at the next cross section, then more definition of the flow geometry is required.

Energy Loss Coefficients: The energy loss coefficients for friction and obstruction losses in an ideal sense should be determined from computations to reconstitute observed field data (highwater marks). Data for calibration of channel roughness coefficients is usually available for major streams, but

seldom available for small channels and is almost never available for the many constrictions in bridges that occur throughout the system. As a consequence, local experience should be exercised for the determination of channel roughness and a number of general guides have been prepared to assist hydraulic engineers in these determinations. Expansion and contraction coefficients that predominate in bridge type computations (discussed in the next chapter) generally are determined from handbooks and have a significant impact on the computations in the vicinity of bridges.

### Sensitivity of Water Surface Profile Data

A question that often arises to those who must spend large amounts of time and energy collecting data and processing results is: How much difference does it make to have accurate and large amounts of data? On the other hand, how much confidence can one have in results that are determined based on a limited set of data? These questions generally relate to the amount of stream geometry data available, which can be directly controlled by the amount of field surveys. It is obvious that the accuracy of the cross section data as well as the longitudinal frequency with which cross sections are obtained have a direct impact on the accuracy of the computed results. Another element less subject to field measurement is the amount and distribution of channel roughness as reflected by the Manning roughness coefficient.

Most studies of accuracy attempt to isolate random and systematic error in cross sections, for example, by comparing USGS quadrangle cross section type data with field surveys. For cross section data, it seems that in selected studies referenced in the literature, differences of up to 1 to 4 feet in computed water surface elevations can occur when comparing results from field surveys to cross section data obtained from standard 7-1/2 minute USGS quadrangle sheets. Differences in cross section spacing can result in a range of small differences computed elevations to very large differences, if the rates of energy loss are significant. Differences of over 4 feet in computed elevations have been observed in published results. The results for the energy loss coefficients (expansion and contraction) seem to be relatively insensitive in computation of profiles, but can be significant near bridges. Also an interesting observation is that profiles are not

especially sensitive to differences in flow rate, indicating that the precise determination of flow rates is not always required for reasonable delineation of water surface elevations.

Included in Appendix B is an HEC paper that shows the results of a specific sensitivity study that was performed to develop a quantitative comparison of the resulting differences in computed water surface elevations. A study of this example should provide some background for judging the reliability and utility of water surface profiles computed from varying data and varying assumptions.

QUESTIONS  
CHAPTER 12  
WATER SURFACE PROFILE COMPUTATION

1. Must the water surface elevation always decrease in the downstream direction? Explain your answer.
2. Given a flow rate, can the water surface elevation at an arbitrary point in a natural channel be directly determined by observation of the geometry at the location alone? Can it be determined approximately by this observation? What is the assumption that is made for this determination?
3. What types of studies would warrant the detailed computation of profiles as discussed in this particular chapter? What are the alternatives to detailed computations and where would they be appropriate and defensible?
4. Under what condition would a two-foot error in the computation of the 100-year flood level (assuming the correct flow is exactly known) be of major significance in a planning study?

DISCUSSION TO QUESTIONS  
CHAPTER 12  
WATER SURFACE PROFILE COMPUTATION

1. No, discontinuities in the profiles can occur from abrupt changes such as at a hydraulic jump or rapid increase in flow areas. The usual notion of water level decreasing in the downstream direction is, however, valid.
2. No, not without some simplifying assumptions. It can be determined approximately by assuming flow to be occurring in the "normal" state (rate of energy loss just balanced by fall in channel invert), and assuming the energy gradient can be determined from the ground slope. The Manning formula would then be used to compute the elevation.
3. With the increased refinement in computer technology and automated means of acquiring geometric data, there is less need for shortcut methods. Certainly most survey and local project investigations require reasonably accurate profile data. Perhaps some reconnaissance studies may not require detailed profiles. An alternative to profile computation is projection by map studies of observed high water marks and gaged rating relationships.
4. The point of this question is to cause reflection on the part of the reader as to his perception of the accuracy of profile computations. A two-foot error should not be expected to be a common occurrence but is by no means especially rare.

CHAPTER 13  
FLOW IN THE VICINITY OF OBSTACLES

Introduction

This chapter will discuss the nature of flow profiles and energy losses that occur in the vicinity of channel features that cause increased energy losses or modify boundary conditions. The discussion will focus on flow in the vicinity of such structures as bridges, and the influence these structures have on flow both upstream and downstream. As a necessary background for the discussion of the effect of changes in profiles, the family of possible shapes of water surface profiles under the varying classifications of flow conditions discussed in previous chapters must be defined.

Boundary Effects

The shape that a specific water surface profile will assume is a unique function of the energy state of flow and the flow classification that exists at that particular point in a stream system. In order to discuss these profile shapes, it is convenient to once again assume an idealized condition of a prismatic channel with gradually varied flow conditions occurring.

Figure 13.1 contains four families of water surface profiles that can exist under varying classifications of flow for a range of channel slopes.

The family of curves that are of primary interest are those shown for the MILD slope condition. MILD refers to the condition, given the rate of all of the channel bottom, that would result in an equilibrium flow that is subcritical. For subcritical flow, all disturbances that may be introduced into the profile can be transmitted upstream. Note that each of the profiles shown in the MILD condition are controlled from downstream. The importance of this situation is that any change away from equilibrium (the line between regions 1 and 2), such as might be caused by an obstruction, will modify the profile upstream but will have no effect whatsoever in a downstream direction.

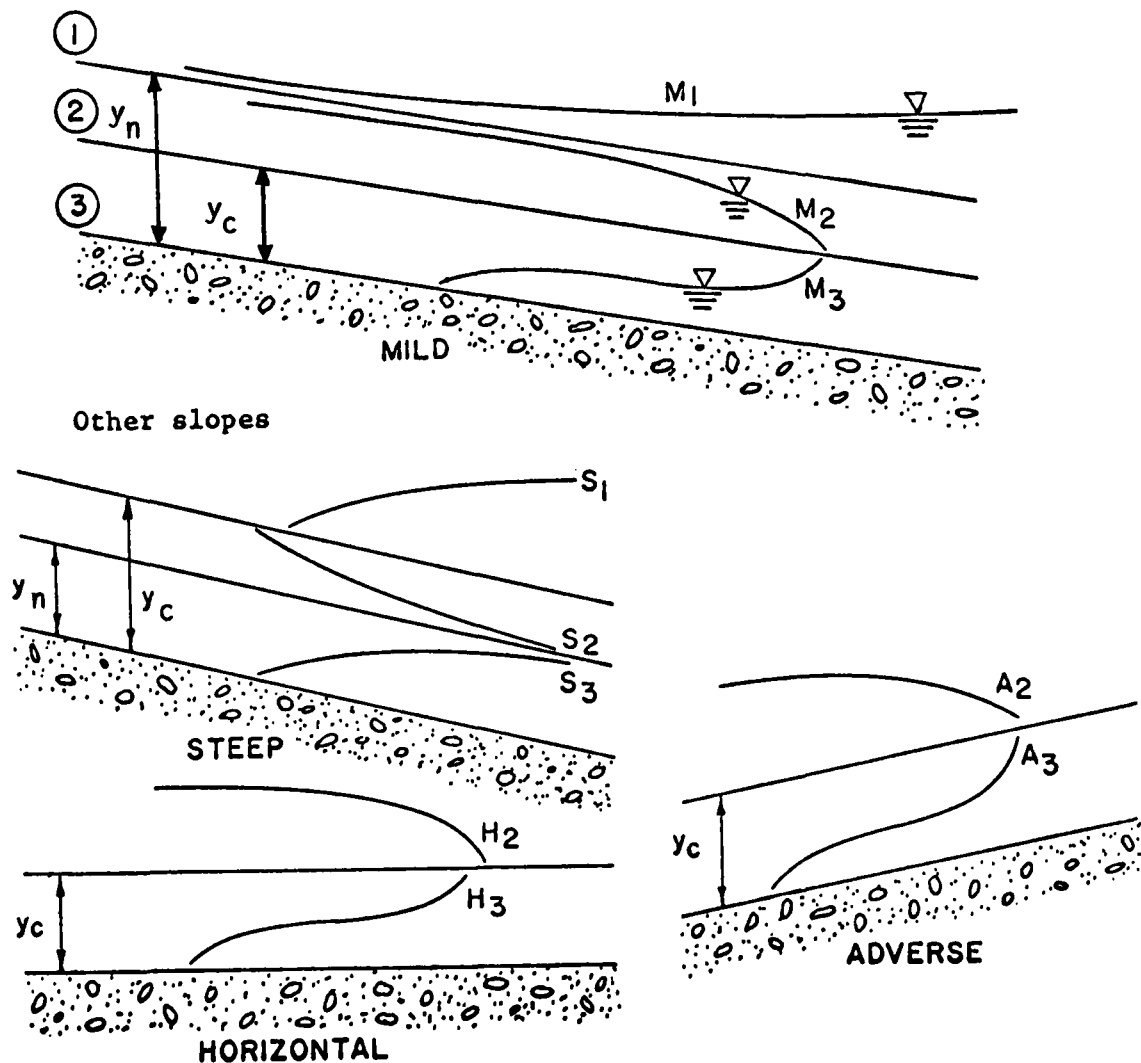


Figure 13.1 WATER SURFACE PROFILES

The labels on the profiles are for identification purposes. For instance, the M-1 profile indicates the category of water surface profile that exists in the region which is above the equilibrium flow depth ( $y_n$ ). The M-1 profile is that which is classically referred to as a "backwater" profile. It should be emphasized that only those particular profiles shown there in the MILD condition can in fact exist. It is impossible, for instance, for a water surface profile to show a decreasing depth in the downstream direction for a flow condition that is above the equilibrium flow depth. The M-1 profile is the only possible shape of water surface within that region. Likewise within the region between the equilibrium flow depth ( $y_n$ ) and the critical depth ( $y_c$ ), the M-2 profile is the only one

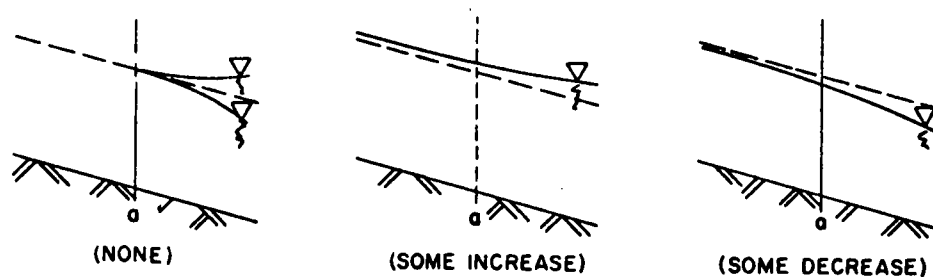
possible. At times, the M-2 profile is referred to as a "drawdown" curve such as might occur in an approach channel to a pumping plant.

Perhaps the next most common situation would be the horizontal slope condition for relatively flat and slightly undulating natural channels. The steep condition is reserved almost exclusively for man-made channels and very steep mountain streams. It is worth emphasizing again that each of those profiles shown in each of those categories are the only ones that can exist when the water depth is within the region indicated.

### Boundary Effects

The upstream and downstream effect of disturbances introduced to the flow will be discussed. The framework for discussing the effect of flow disturbances involves the assumption that the conditions are initially in equilibrium prior to the introduction of a disturbance (or obstacle) to the flow. The different profile that results will be caused exclusively by the introduction of the obstruction.

Subcritical Flow: Figure 13.2 indicates the changes that will occur in an equilibrium profile that exists for flow occurring in the subcritical state.

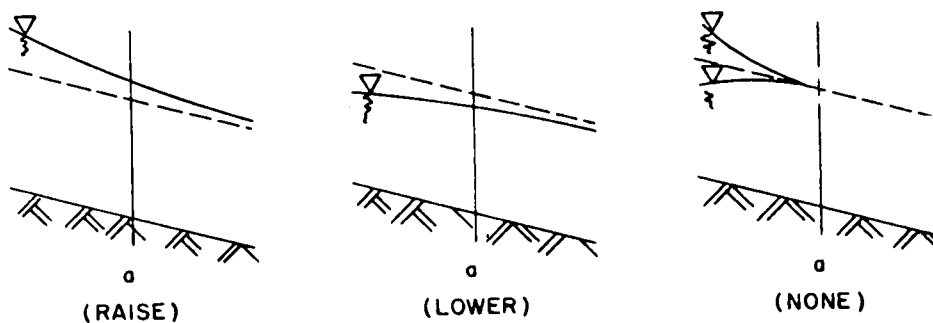


**Figure 13.2 SUBCRITICAL FLOW PROFILES**



Note that an obstacle, such as a bridge or other construction, placed in the flow will cause the water surface profile to change in the upstream direction while "downstream" the profile will remain unchanged. "Downstream", is defined here as a sufficient distance downstream for flow to reestablish from the turbulence generated by the local obstruction. This will be discussed subsequently when the "near" aspect of defining flow in the vicinity of bridges is described. Also note that there is both the possibility for a decrease and an increase in the water surface elevation proceeding upstream and merging to the original condition. These two conditions correspond to the profiles shown above for the MILD slope condition in regions 1 and 2. It is possible to drastically alter the flow by constricting the condition to such an extent that the state of flow is completely changed and cause a transition from subcritical to supercritical to occur, however, this is rare in a natural channel.

Supercritical Flow: Although supercritical flow occurs much less often than subcritical flow, there are instances where structures are placed in man-made flood control channels and other such works that make it essential that one understand the effect of obstructions in this case as well. Figure 13.3 indicates the effect of disturbances introduced into supercritical flow.



**Figure 13.3 SUPERCritical FLOW PROFILES**

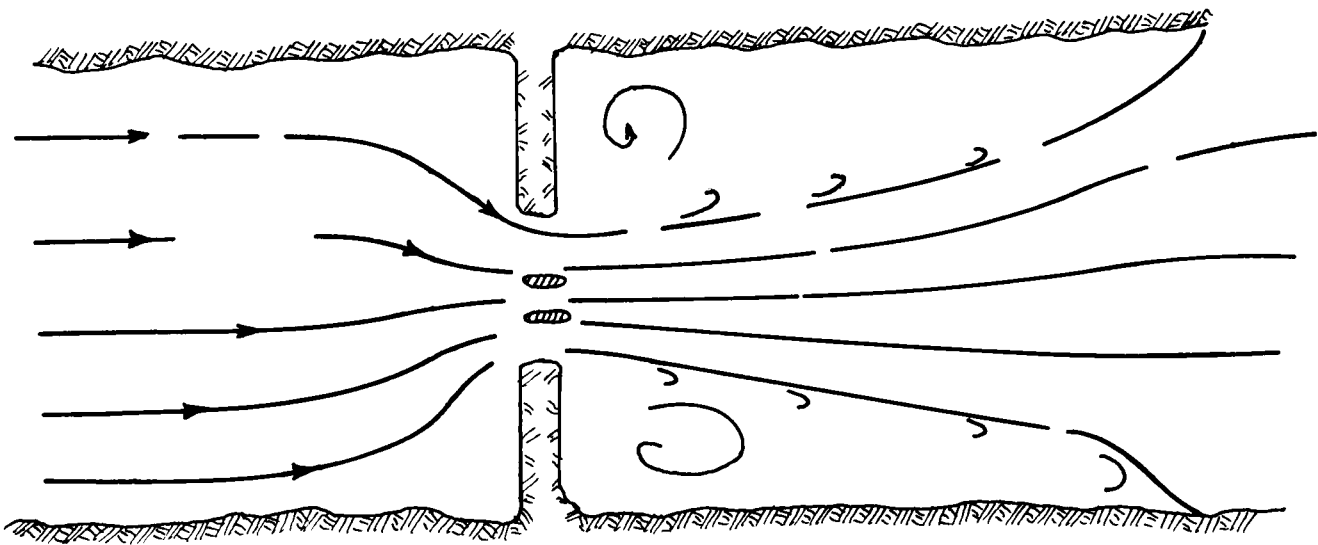
Note in this instance that the disturbance caused by an obstacle in the flow is reflected downstream and not upstream. The situation corresponds to the profiles that are categorized as STEEP and are within regions 2 and 3. An obstacle, such as a bridge piers in the flow, will cause the water to rise and then decrease to the equilibrium condition in a downstream direction. In the absence of a severe obstacle to the flow, no effect of the placement in the flow will be transmitted and reflected in upstream changes in water surface elevation.

It is significant to note that for both the subcritical condition and the supercritical condition, the flow is apparently able to adjust such that at some location either far upstream in case of subcritical or far downstream in case of supercritical, the effect of introducing a substantial change in the flow pattern is not apparent. This is important when trying to draw conclusions about the beneficial or adverse effect of management works that modify the energy loss or flow conveyance characteristics at a specific point in a stream.

### Profiles at Obstacles

The discussion thus far has dealt with the modification to the water profile conditions in the upstream and downstream directions away from the obstacle itself. It was carefully pointed out that the profiles were for conditions that were not defined as "near" the obstacle to the flow. The reason for that is indicated in Figure 13.4. The figure is for a bridge showing the effect of constricted approach embankments and piers in the flow. The flow is concentrated coming into the bridge and expands and slows down passing downstream. In this vicinity the profile has a shape that is not consistent with those previously discussed. The vicinity labeled "near" in the sketch corresponds to the definition described in the introductory chapter as "rapidly varied flow," which refers to the flow condition that is changing so rapidly that the pressure distribution is no longer hydrostatic, and the flow field is significantly two dimensional.

The length involved is generally considered to be approximately a distance upstream equivalent to the width of the constricted opening and a distance



PLAN

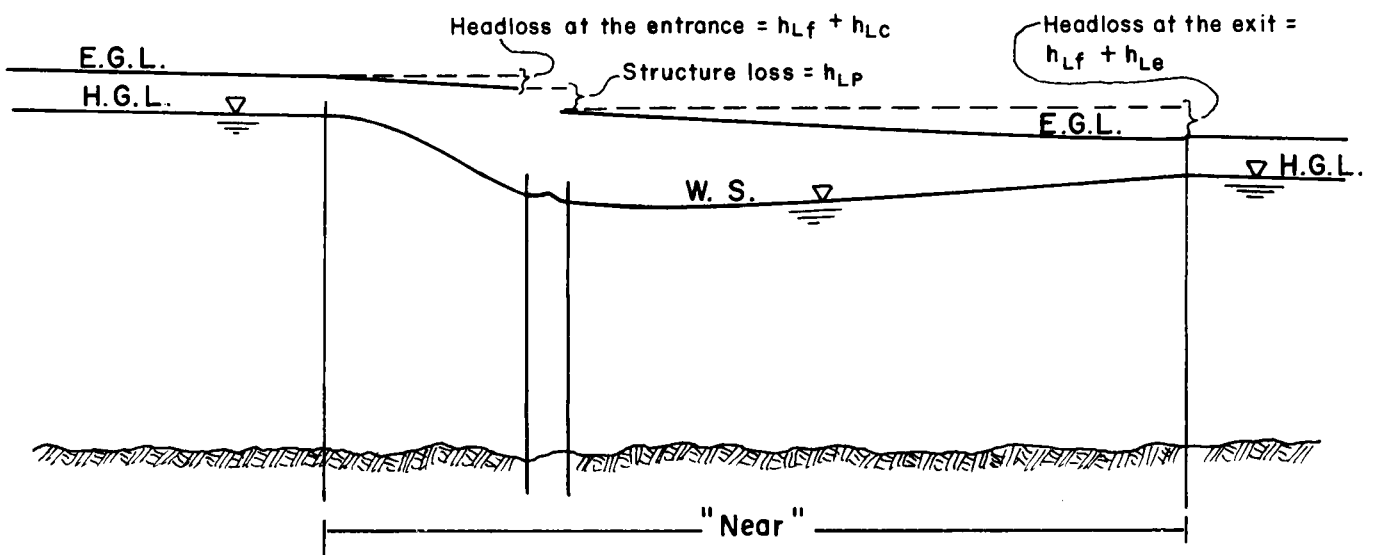


Figure 13.4 EFFECT OF PIERS AND EMBANKMENTS

downstream equivalent to four times the width of the constricted opening. In this situation, the Bernoulli equation is not applicable. The physical cause of the nonapplicability of the general energy equation is that there are significant local accelerations. Notice that in order for the flow to pass through the bridge, it must pass at a significantly faster rate than upstream and, therefore, must accelerate. The internal forces required to accelerate the flow causes the pressure distribution to become nonhydrostatic. Note also that the flow must change direction which also results in an acceleration. In such instances as this, the water surface is not located at the piezometric pressure surface as it would be in a simple tank or in a flowing stream.

Within the bridge itself, "near", the water surface elevation transverse to the direction of flow is not horizontal. In other words, the water surface elevations, comparing the outside near the bridge embankment with the center of the channel, are different, and each is usually significantly different from the approach water surface elevation. It is this uncertainty that makes it almost impossible to trace, in detail, the water surface elevation throughout the "near" region in the vicinity of the bridge. The lack of a horizontal water surface and the nonhydrostatic pressures make it especially difficult to compute flow rates from observed high water marks near bridge embankments. As an upper limit, the water surface elevation within the bridge constriction can be considered to not exceed the elevation of the energy grade line at that point.

### Energy Losses

Energy losses in the "near" vicinity of obstacles, such as those resulting from constrictions at bridges, are caused by increased friction loss and form losses that are generated by internal fluid friction. The physical process causing increased energy losses can be divided into four categories.

- o Increased friction loss over that which would occur in the absence of the constriction. Obviously the flow rate must increase in order to pass the constriction.

- o Contraction loss - the internal friction loss, classified as a form loss caused by concentrating and accelerating the flow in the contraction zone.
- o Expansion loss - the internal friction loss, also classified as a form loss, caused by the necessity to slow the flow and spread it to its previous condition. This usually involves some eddy losses along the side of the expanding flow.
- o Impact losses - the loss that is generated due to turbulence caused by the impact of the flow on the piers (or other obstacles that might exist in the flow field).

The increased friction loss is at times not evaluated separately but is assumed to be included within the computations for the contraction and expansion losses. Methods in use by Corps offices generally include the components described. The energy losses associated with expanding and contracting flow have been found to be related to the change in velocity head as follows:

$$h_L = K_L \left[ \frac{v_2^2}{2g} - \frac{v_1^2}{2g} \right]$$

where

- $h_L$  = Energy loss due to expansion or contraction
- $K_L$  = Contraction or expansion energy loss coefficient
- $v_1, v_2$  = Velocity at respective locations outside and within contraction

The computational methodology for determination of the loss due to impact is accomplished by a number of means, some of which incorporate the overall loss in a coefficient for the entire bridge including the entrance or exit losses. A more systematic method used by a number of computational programs determines the drag exerted by the structure on the flow then performs a force balance analysis to determine the associated loss.

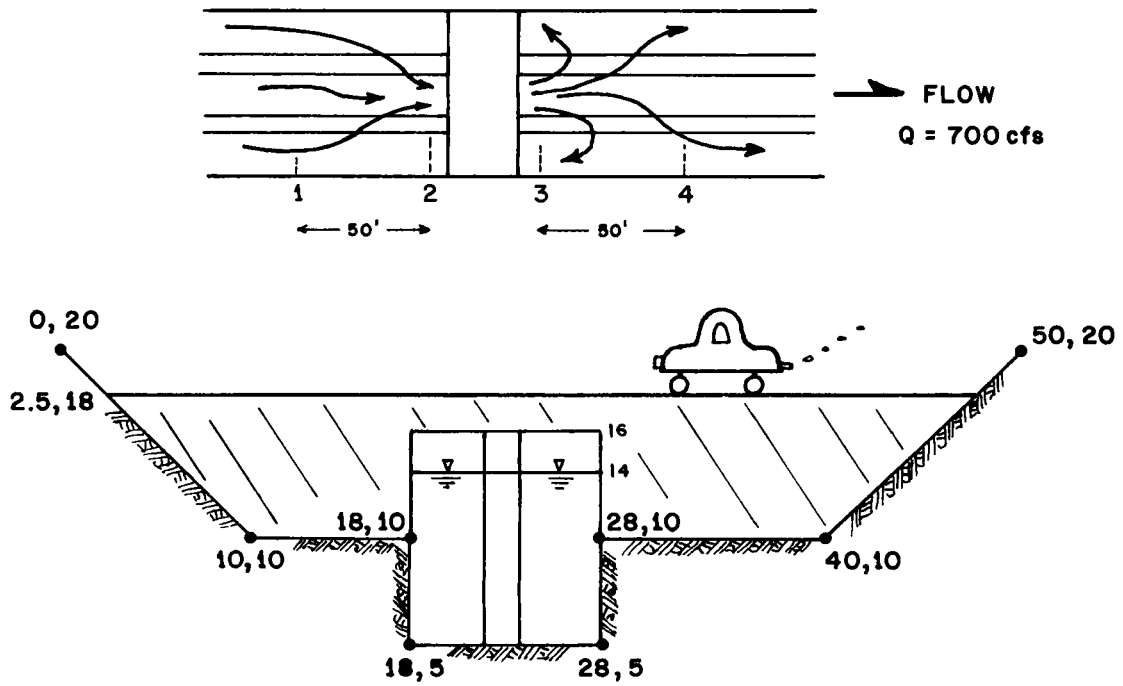
An example of the relative importance of each of these conceptual loss components is shown in Figure 13.5. The specific losses indicated are unique to the flow condition shown, but the relative proportions among the losses are reasonably representative. Note that the expansion loss is approximately twice the contraction loss, and that it is about the same order of magnitude as the obstruction loss. The friction loss indicated is the total amount (including that which would occur naturally without the bridge) so that if the bridge were removed, not all would be recovered because some exists in the absence of the bridge.

Considerably more complicated flow conditions can occur in the vicinity of obstacles which requires advanced hydraulic analysis. In such cases it is quite difficult to generalize the nature of the flow field, the amount of energy losses that would occur, and the significant aspects that would be of interest in a planning study. Figure 13.6 indicates the complications that occur for very high flows around bridges.

Note that the roadway and the approach embankments become overtopped, considerable turbulence is generated, and the simple concepts that have been thus far discussed are no longer in operation. Methodologies have been developed for analysis of such situations but they should not be considered as accurate or as correct as those for the less complicated flow and concepts previously discussed. For instance, when bridges become overtopped and the road deck is impacted by debris, it is quite likely that the bridge itself would fail. This is a situation that is very seldom analyzed for high flow condition.

### Summary

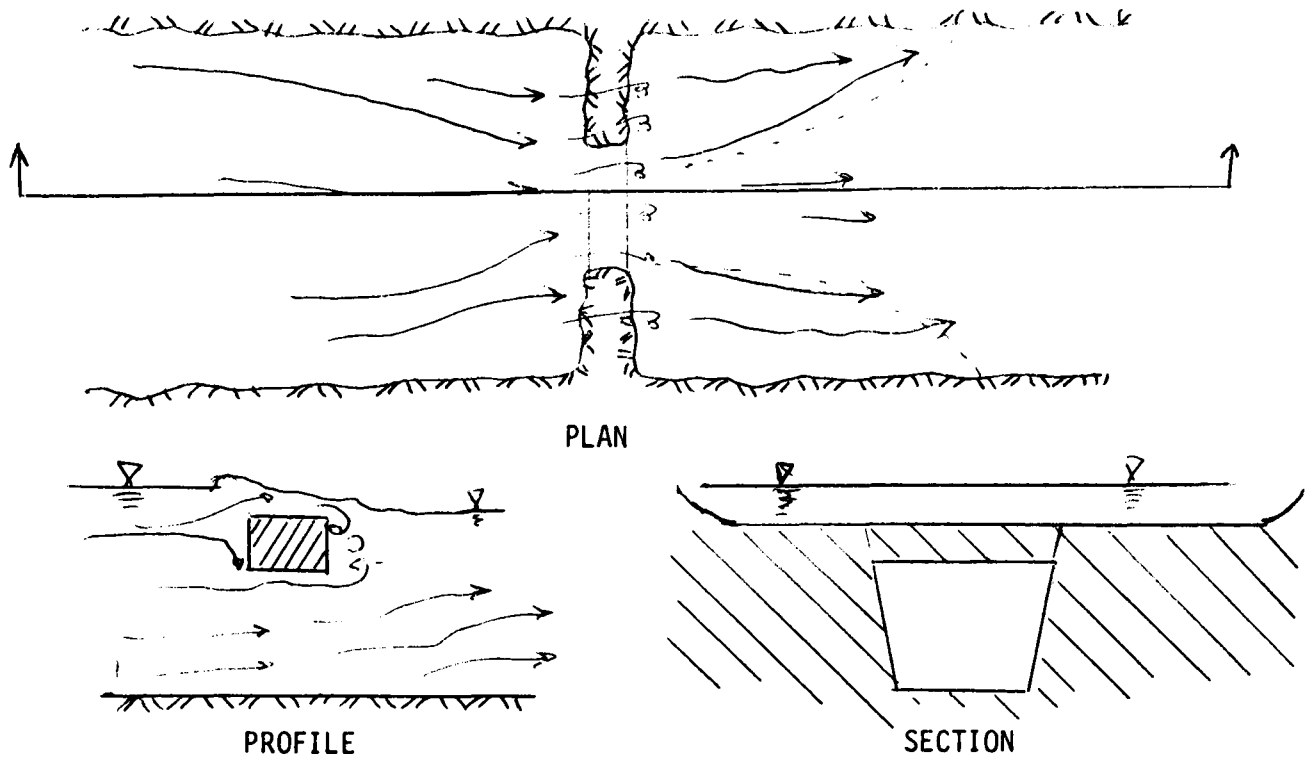
This chapter has discussed the general effects of the introduction to any, by inference, the removal of obstacles from flow. It is important to realize that not all changes in flow can be transmitted upstream or downstream. The specific changes that can occur are dependent upon the state of flow and the amount of change that is introduced. As a consequence, analysis of the modification of flow conditions within congested areas (such as urban areas) and analysis of improved flow conditions (such as channel



ENERGY LOSSES  
(feet)

Section	Friction Loss	Contraction or Expansion Loss	Pier Obstruction Loss
1 - 2	.12	.23	--
2 - 3	--	--	.52
3 - 4	.18	.42	--
$\Sigma = 1.47$	$\Sigma = .30$	$\Sigma = .65$	$\Sigma = .52$

Figure 13.5 ENERGY LOSSES



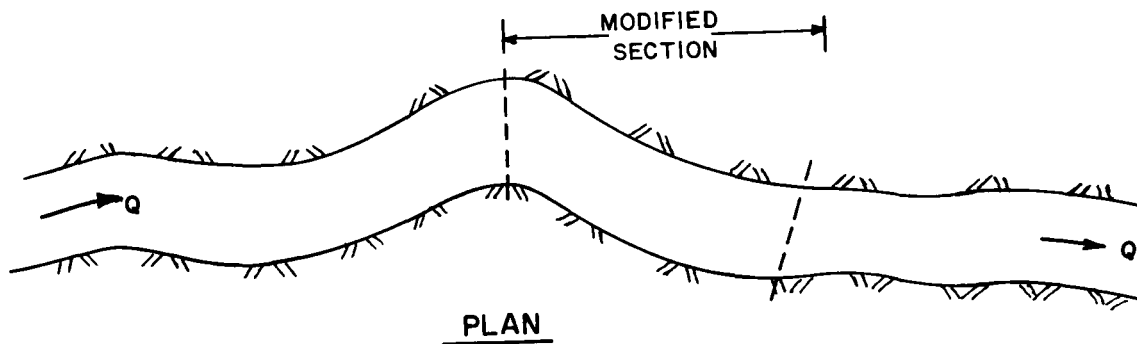
**Figure 13.6 FLOW AROUND OBSTACLES**

work) should be based upon sound scientific principles as have been discussed. It will not always be obvious as to whether management works will in fact be beneficial or adverse to relation to its effect on the water surface elevation.



QUESTIONS  
CHAPTER 13  
FLOW IN THE VICINITY OF OBSTACLES

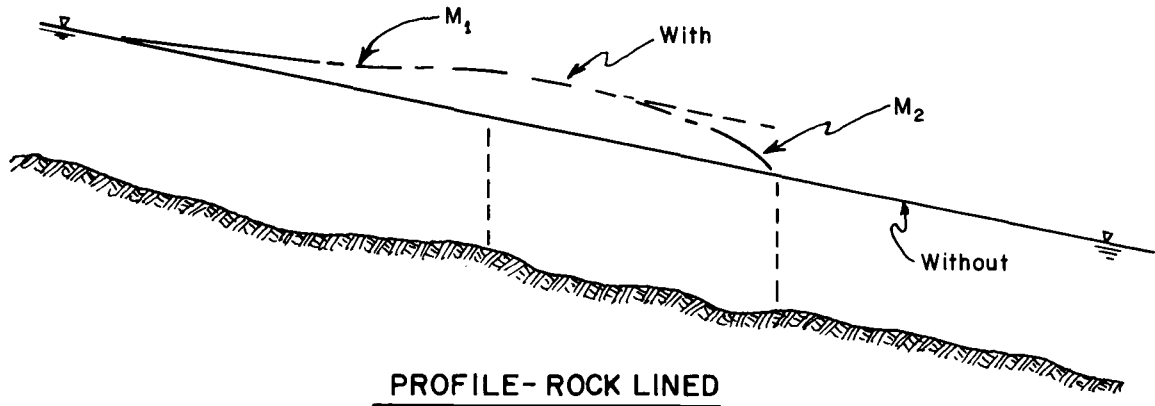
1. What is the hydraulic effect of rock lining a part of a smooth channel? For the subcritical condition would this effect extend upstream or downstream? What type of change in water surface elevation might be expected both within the area where the rock lining is introduced and either upstream or downstream?



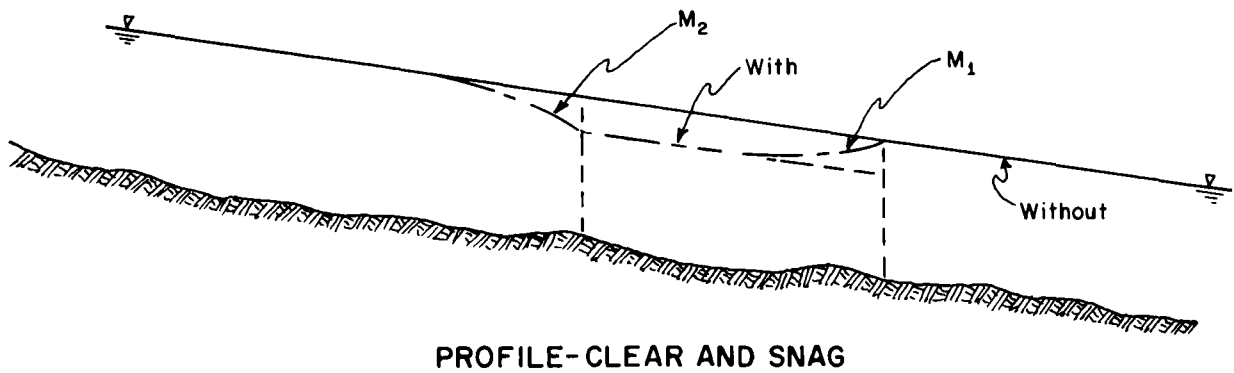
2. Answer the questions in (1) for the effect of clearing and snagging a stream reach that is presently clogged with debris and vegetation along the banks.
3. Suppose two bridges exist in proximity to one another in a stream channel in an urban area and that the water surface elevation at a point upstream is controlled by energy losses generated by both bridges. Discuss whether improving channel conditions by enlargement or dredging would have significant value on reduction of water surface elevations. Why are your conclusions as they are? Would removal of both bridges cause water surface elevations downstream of those bridges to be different than they were with the bridges in place? Would removal of the upstream bridge result in an increase in the level or load of water on the downstream bridge? Discuss.

DISCUSSION TO QUESTIONS  
CHAPTER 13  
FLOW IN THE VICINITY OF OBSTACLES

1. Within the rock lined section, the water surface elevation would increase and this would be reflected for some distance upstream. There would be no effect downstream. The sketch below indicates the effect.



2. Clearing and snagging would reduce the water surface elevation within a transition zone in the lower modified reaches and a transition zone upstream of the reach. The sketch below indicates the effect.



3. Channel improvement would probably have little value in the area near the bridges because the elevations are being controlled by bridge losses. Removal of both bridges would lower the upstream water level but would not effect the downstream area. The same is true of removal of one bridge.

## CHAPTER 14

### UNSTEADY FLOW HYDRAULICS

#### Introduction

In technical studies, water flow in natural or artificial channels is generally classified as steady or unsteady. Flow of water where the velocity changes with time in river channels, canals, reservoirs, lakes, pools, and free surface flow in conduits or tunnels is defined as unsteady open channel flow. Water flow in channels is almost always unsteady, but when the change of discharge with time is very gradual, unsteady flow can be approximated by steady flow. The discharge hydrographs of flow in natural water courses are largely comprised of flood waves (hydrographs) followed by recession curves. Only those flows occurring during a prolonged drought and those occurring for short time intervals at the highest and lowest points of the hydrograph can be considered to be steady flow. For analysis purposes, it is appropriate at times to select parts of unsteady events and analyze them as if they were steady, such as analysis of peak flows as if they were steady. For practical purposes, the answer is directed by judgment rather than by criteria that have been developed mathematically or experimentally.

The mathematical treatment of unsteady flow in any channel is considered to be among the most difficult problems in fluid mechanics. Basically, this difficulty exists because many variables enter into the functional relationship and because developed differential equations cannot be easily solved.

Unsteady flow is a broader concept which includes the technical subject area of flood routing. For the purposes of this chapter, flood routing will be referred to in a rather elementary manner as the type of analysis that focuses upon volume conservation, a topic discussed in earlier sections of this manual. The distinction is necessary more from a historical perspective than from a theoretical standpoint. Historically, hydrologists concerned primarily with rainfall runoff and 'natural' streamflow developed and applied simplified techniques which were necessary to compute flow rates through watersheds. Many refer to these methods as 'hydrologic routing' methods. In

a parallel path, hydraulic engineers concerned with estimating water surface elevations, designing canals and channels and analyzing conditions in tidal estuaries proceeded to develop a more complete theoretical structure for steady and unsteady flow analysis. The numerical solution of differential equations related to these areas was aided by the advent of the computer age. Many refer to these methods as 'hydraulic' routing procedures. Unsteady flow within the context of this chapter is synonymous with 'hydraulic' routing concepts.

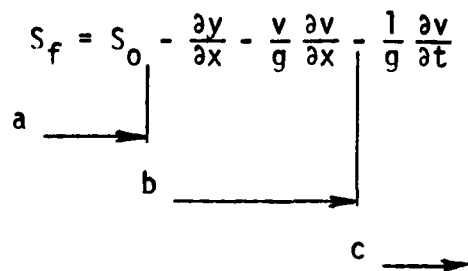
### Application Areas

Examples of physical settings for which unsteady flow analysis is appropriate include tidal portions of rivers and estuaries; areas downstream from artificial control works that may be operated rapidly, such as sluice gates or hydropower installations; or areas in the vicinity of facilities that may fail, such as pumping stations experiencing power failures and dams that may collapse. For instance, estimation of the water surface elevations near the downstream vicinity of a gated structure that changes releases from 1,000 cfs to 5,000 cfs in 15 minutes would require unsteady flow analysis, whereas if the change occurred in 3 to 4 hours or the location of interest was far removed from the change, more simple routing methods would probably suffice. In general, changes that result in significant alteration of flow (or stage) on a time scale in terms of minutes (or a very few hours) will probably require a more complex unsteady flow analysis.

The factor which most significantly determines whether or not an "unsteady" analysis is required in comparison to a more simple 'routing' is the speed with which flows and water surface elevations change in relation to the damping nature of the hydraulic system. Newton's second law states that for any mass the force balance difference results in (or is caused by) acceleration. In the flow of fluids the unbalanced force resulting from acceleration (in time or space) is frequently referred to as inertia. One speaks of unsteady analysis becoming necessary when the 'inertia' component of the unsteady flow energy equation becomes 'significant'. What constitutes 'significant' is a matter of professional debate and requires experience and judgment to determine.

## Theoretical Structure

The governing theory for one-dimensional (i.e., one value of velocity and elevation at a point) gradually varied unsteady flow may be derived from Newton's basic laws of physics. The complexity of analysis stems from the resulting equation being a nonlinear partial differential equation for which exact solutions cannot be found. In addition the nature of the governing theory, and for that matter the actual dynamics of flow, is such that it is extremely difficult, if not dangerous, to generalize without detailed analysis. A formulation of the equations that allows observing (in a mathematical sense) the increased analytical structure is as follows:

$$S_f = S_o - \frac{\partial y}{\partial x} - \frac{v}{g} \frac{\partial v}{\partial x} - \frac{1}{g} \frac{\partial v}{\partial t}$$


where

- $S_f$  = rate of energy loss (slope of energy line)
- $S_o$  = rate of fall of topography (slope of stream bottom)
- $y$  = vertical depth
- $x$  = longitudinal distance
- $v$  = flow velocity
- $t$  = time
- $\partial$  = partial operator (indicates partial derivative)

The terms up to (a) define steady uniform flow ( $S_f$  the rate of energy dissipation is balanced by  $S_o$  the rate of energy addition). The terms (all included) up to (b) define steady nonuniform flow (part of the rate of energy addition is balanced by the local accelerations reflected in the additional

terms). The terms up to (c) define unsteady nonuniform flow (part of the rate of energy addition is additionally balanced by the convective acceleration). The relative magnitude of these terms (one compared with the other) provides some insight into the notion of 'significant inertia' referred to in previous paragraphs. As shown in Reference 1, for example, for a relatively steep stream experiencing a fast rising flood that increased in flow from 10,000 to 150,000 cfs and then decreased to 10,000 cfs again with 24 hours, the values of each term are:

$$S_0, \frac{\partial y}{\partial x}, \frac{v}{g} \frac{\partial v}{\partial x}, \frac{1}{g} \frac{\partial v}{\partial t}, S_f$$

'feet/mile 26, 1/2, 1/4, 1/20, remainder

The inertia term and terms other than friction are almost insignificant so unsteady flow analysis which requires the full equation is unnecessary. If the above relative values (excluding  $S_0$ ) were for a stream sloping at the rate of 1.5 ft per mile, the conclusion would be much different.

### State-of-the-Art

The state-of-the-art in methods of solution of unsteady flow problems is advancing at a rapid pace. The theoretical structure of the governing equations is well defined for gradually varied unsteady one-dimensional flow for prismatic channels of uncomplicated geometry (e.g., no significant discontinuities such as overbank flood plains). Numerical procedures have been developed for solution of the differential equations that are reasonably reliable so that field level applications by qualified engineers can be reasonably assumed.

The same is not true for channels that are nonprismatic and is especially not true for most natural channels with complex geometry. Theoretical formulations exist, but difficulties arise in their numerical solution. A number of simplifying assumptions which must be made (such as uniform velocity distribution) cause some to suspect the results. Presently, the assistance and advice of experienced professionals specializing in unsteady flow is necessary for development of engineering answers to problems requiring unsteady flow analysis in natural stream systems.

QUESTIONS  
CHAPTER 14  
UNSTEADY FLOW HYDRAULICS

1. What is meant by unsteady flow?
2. Under what conditions may the general principles of unsteady flow become significant?
3. What is inertia? What feature of flow situations causes it to be important?
4. Discuss planning situations that may require the application of the concepts described in this chapter.

DISCUSSION TO QUESTIONS  
CHAPTER 14  
UNSTEADY FLOW HYDRAULICS

1. Unsteady flow refers to a condition in which one or more of the flow parameters, such as flow rate, depth, or velocity changes with time; and in the context used in this chapter, refers to situations wherein the change is so rapid that inertia becomes important.
2. Unsteady flow principles are important for situations in which accurate representation of the changing parameter (such as depth) is needed in a flow condition that is varying so rapidly that inertia is important.
3. Inertia is the unbalanced force resulting from acceleration. In flow, it is the result of rapid changes in time.
4. Planning situations that may require that unsteady flow principles be applied include:
  - hydropower, downstream flows
  - locks
  - pumping facilities (especially power failures)
  - tidal estuaries
  - dam failures



CHAPTER 15  
SEDIMENT TRANSPORT IN NATURAL STREAMS

Introduction

The form of the landscape is very much determined by longer term geologic processes. A major agent in shaping the landscape is movement of weathered and eroded materials by flowing water. The ability of streams to transport sediment is common knowledge, but the specific nature of land surface erosion, stream scour and deposition, and sediment transport remains as a major research area for scientists.

The phenomena of scouring sand, gravel and even large boulders from the bed or banks and their transport downstream is usually termed sediment transport. In a great many situations, the phenomena is of significant economic importance. The cost and value of flood control scheme is critically dependent on estimates of maximum flood level; the level may in turn be seriously affected by scour and subsequent downstream deposition of sediment, either temporarily during the course of a single flood or part of a more permanent long-term process. Bridge piers may be undermined during passage of a flood. The deposition of sediment in reservoirs transported there by streams occupies valuable storage space. Use of rivers for navigation may require costly maintenance dredging activities.

In dealing with these examples the engineer is seeking to control this process (at least to a limited extent) to accomplish project objectives.

Geomorphology

In a very simple conceptual sense, the long-term geologic processes are driving towards converting the landscape to a flat plane through the processes of weathering, mass wasting, erosion and deposition. A great many variations cause this very simple view to be wholly inadequate and at best a simple point of reference. The major variations that cause the situation at a specific geographic location to be complex are that nature periodically interrupts the process and rejuvenates the landscapes (builds new mountains),

and the rate of which mass wasting, weathering and erosion occur are functions of the weather regime, the competency of the rock structures, and the transport capacity of the streams.

Time Scale: It is valuable to fix in one's mind a range of time scales and hierarchy of processes that are involved in any given stream situation.

1. Geologic Time - long-term transition from young landscapes to mature to aged.
2. Project Time - current to medium term (100 yr  $\pm$ ) trends of erosion/deposition dependent upon available sediment supply and stream transport capacity.
3. Major event - specific flood.
4. Instantaneous - the sediment transport at a specific instance in time.

It is quite likely that at a specific location in a stream, in geologic time the location is receiving material deposits (a low river valley), within the life of a project, the area may be undergoing erosion and scour (the flow is artificially constricted), within certain major events deposition is occurring (may be located within the backwater area of a stream control device) but at a specific instance during the passage of a flood, significant scour may occur because of the presence of a structure such as a bridge pier. On the other hand a short distance away, many of the above processes are just the opposite. The time frames of interest to the engineer and planner are those that lie from the project time frame to the instantaneous.

### Transport Capacity

It is generally recognized that nature maintains a delicate balance among the water-sediment mixture flowing in a natural stream, the sediment material forming the boundary of the stream channel, and the physics of the flow. A relationship reflecting this balance is:

$$Q_s \cdot D_{50} \approx Q \cdot S_f$$

where

$Q_s$  = bed material load

$D_{50}$  = sediment size

$Q$  = water discharge

$S_f$  = rate of energy dissipation (slope of energy line)

A channel is maintained in dynamic equilibrium by balancing changes in sediment load and sediment size with compensating changes in discharge and energy gradient. The main value of the above equation is not quantitative but qualitative in the sense of providing a frame of reference for discussing the impact of changes to the water sediment mixture on the behavior of the river channel conveyance system.

Equilibrium of Stream Profiles: If the yield of bed material should increase (more sediment added to the sediment by upland erosion), the equation forecasts that either the effective size of particles in the sediment must decrease (the sediment load must become finer) or the system will be out of balance. A system out of balance in this manner will adjust itself by increasing the energy slope until the flowing bed load material can be transported (upstream reaches will undergo deposition (termed aggradation) to increase the slope of the channel bottom.

If, at some future time, the inflowing bed material load returns to its original value, the aggradation trend will cease and scour (termed degradation) will begin. Starting at the upstream end, sediment material will be removed from the stream bed and the slope will return toward the original value.

In an undisturbed natural stream situation, the annual water discharge and the effective sediment size remain fairly constant while the energy gradient varies from point to point. The sediment load must therefore change from point to point. This requires sediment reservoirs along the stream bed from which material can be withdrawn (sources) and into which material can be deposited (sinks).

The quantitative functioning of sinks and sources during the passage of a flood and the shifting of their locations in the short and longer term is the basic objective in sediment transport analysis.

### Sediment Transport

The material transported by a stream is generally classified as bed load and suspended load. The suspended load is generally further classified into suspended bed material and wash load, the distinction being that suspended bed material load is material composed of similar grain sizes and amounts naturally found in the stream bed.

The bed load is transported by sediment particles rolling and hopping along the stream bottom. The material generally consists of coarser fractions (sands and gravels) and usually constitutes less than 20% of the total sediment load (though there are important exceptions).

The suspended bed load is transported by entrainment and is supported by turbulence in the flow. There is a continual exchange of material between the bed and suspended portions but the relative proportions remain fairly constant. The coarser material is transported nearer to the channel bottom than the finer material.

The wash load is uniformly distributed throughout the flow and generally consists of finer fractions, down to clay sizes. Sediment transport theory covers on the transport of material classified as bed load and suspended bed material load.

The source and gradation of the sediment load should be accurately identified to properly evaluate potential effects of changes to natural streams.

### Stream Regime

Streams and rivers can usually be divided according to the topography of the river basin into two parts: the upper reaches in a hilly region and the

lower reaches on the alluvial plain. Rivers in the hilly region are characterized by steep slopes, swift flow, the formation of rapids along their courses, and the presence of large boulders and gravel.

Alluvial reaches usually flow through materials deposited by the river themselves. Depending on the material carried, the alluvium may be composed of sands, silts, or clays frequently covered by fine silt deposited over the adjacent land and flanked by natural levees resulting from deposit of coarser materials during overflow periods.

A river system gradually evolves toward a graded state defined as one in which, over a period of years, slope and channel characteristics are delicately adjusted to provide, with available discharge, just the velocity required for the transportation of the load (sediment) supplied from the drainage basin. Its diagnostic characteristic is that any change in any of the controlling factors will cause a displacement of the equilibrium in a direction that will tend to absorb or balance the effect of the change.

The flowing water in a river is continually shifting the bed material by local scouring and deposition in the river channel. This process takes place in all water courses, and is not to be confused with the slower and more continuous process that occurs in degrading or aggrading rivers. In this case the river is slowly changing its position to a new equilibrium due to external causes such as forest fires or urban development, which have changed the watershed conditions.

Rivers on alluvial plains may be broadly classified into three types: (a) meandering, (b) aggrading, and (c) degrading. These types reflect the obvious net result in seeking long-term equilibrium. An entire length of river is seldom of a single type and all three are usually found from its uppermost point on the alluvial plain to its mouth. If the sediment load and discharge vary with respect to time, any particular section of a river may be aggrading, degrading, or meandering at different times even during a specific flood event.

Generally speaking, where a river has enough capacity to carry the incoming sediment without forming large deposits, it is of the meandering type. Active bank erosion in the bends is common resulting in downstream migration of the bends. Such a stream is probably near equilibrium in terms of sediment supply and transport capacity.

Rivers in which the sediment load exceeds the transport capacity are of the aggrading type. A sediment load which exceeds the river's transport capacity may be caused by several factors: the sudden diminution of slope; a rise in the level of water and flattening of the slope due to an obstruction, a dam, or rise in sea level; the extension of the Delta at the river mouth; tectonic movements; or a sudden inrushing of sediment from a tributary. This is reflected in the river by raising the bed invert to increase the transport capacity. In contrast to a meandering river, an aggrading river is usually straight and quite wide with shoals and islands in the middle which, in an extreme case, may result in braided flow and an intricately woven system of channels. Aggrading rivers often do not actively erode their banks and are frequently quite stable in their lateral location.

Rivers with an excess of transport capacity compared to the available load are of the degrading type. The degrading section of a river may be found above a cutoff, below a dam, or result from regional changes in available sediment supply. Active erosion and rapid deterioration of the banks are common.

#### General Effect of Selected Conditions

Although it is always dangerous to generalize when discussing a complex and not thoroughly understood subject such as sediment transport in natural streams, it seems better to have some general notions (even if in a few selected instances they are wrong) than have none at all. It is within this spirit that discussion of the following selected physical works offered.

Computed Water Surface Elevations: Normally at the end of the low flow season, the river bed is at its highest elevation. Transport capacity is low and the bed remains in place. As discharge increases, the power to transport

material increases. Material is eroded from the bed and the river channel section enlarges. Upon recession of the flood, sediment is deposited and the section is reduced in area. This generalized cyclic change in the river section is a common occurrence in major rivers and is not part of the long-term process. The bed of the Mississippi River, for example, during peak flood times may degrade several meters. On the other hand, the bed may be raised above its original position by deposition during the recession period. The process is sufficiently complex that a simplified discussion may be misleading. Practically speaking, a stream is never completely degrading or aggrading. For instance, during the flood rise, some locations will be actually aggrading while the overall process is one of degrading.

The relationship of discharge and river cross-section, which differs also on a rising and falling stage, is impossible to determine without extensive data. Depending on the date of measurement, cross sections may be either smaller or larger than would occur at specific times throughout the year and since cross sections are generally measured during low water because of access, the higher stream inverts are those generally available for use in calculations. This tends to result in the use of cross section data for rigid boundary hydraulic computations that indicates less flow area than is actually present during the peak runoff period and thus tends to overestimate flood peak elevations.

Levee and Bypass Systems: The objective of levees is to exclude flood waters from overbank areas, which results in the confinement of flows to the main stream channels. The objective of incorporating bypass facilities into a levee system is to relieve the concentration of flow that would result from the levee confinement. The changing of velocity patterns and concentration of flows provide the mechanism for altering the sediment regime. The general hydraulic effect of levee protection along the main river channels will be a moderate increase in water surface elevation and a comparable decrease in velocity in the reaches upstream from the levees, and a similar increase in elevation, but also increase in velocity within the leveed section, and no direct hydraulic effect downstream. The impact of these hydraulic effects are often increased deposition in stream reaches above the leveed area, long-term degradation within the upper reaches of the leveed area, and increased shoaling and deposition in downstream reaches.

The effect of the flood bypass can be to maintain the maximum water surface elevation at the upstream boundary of the levees at near historic conditions. The overall result of the flood bypass would be to restore the hydrograph shape to approximately the historic hydrograph by removing the water that previously had gone into temporary overbank storage and later returned to the river.

If not operated in conjunction with levee reaches, river channels will aggrade immediately below off-take channels because of the change in relative quantities of water, sediment, and transport capacity. Some designs for diversion works attempt to maintain the proper sediment-flow relationship for the stream and diversion channel but this is especially difficult.

Upstream Storage: The most dramatic influence on sediment conditions in a river will be caused by the development of upstream storage. Most significantly, retention of sediment and modification of the hydrograph occur as a result. The reservoir will trap the majority of the entering suspended load and all of the bedload. The total sediment trapped will generally be deposited in the upper reaches of the reservoir.

The change in the river system downstream from the reservoir results from both the trapping of the sediment load and alteration of the hydrograph. Degradation immediately downstream will commence at once due to the absence of the sediment in releases. The source of sediment available to replenish the flow is obviously only the river channel itself. Degradation will occur until either resistant material is encountered (the invert is stabilized by the exposure of sufficient coarse material to armor the channel boundary) or the gradient is reduced sufficiently to minimize scour. The effect will increasingly extend downstream depending on the specific location of the reservoir and material encountered in the downstream channel. The extent of degradation can be several meters and hundreds of millions of tons of material and extend for tens or hundreds of miles, as has been the case for the reach below Hoover Dam on the Colorado River.

The second major downstream effect of storage reservoirs on the sediment regime stems from the alteration of the historic hydrographs through



regulation. This is, of course, the primary purpose of flood control and irrigation storage. Depending on the specific mode of regulation, prolonged releases may result in annual sediment conveyance capacity greater or less than historic levels. Another important variable is the regulated flow in respect to the tributary inflows, e.g., whether a historic coincidence or noncoincidence is altered.

Since the net general effect of reservoir storage is degradation of the downstream channel, it is likely that the pattern of shoaling will change, and attack on the banks as well as the invert will result. Bank protection to insure a stable channel location may be required at critical locations as time passes.

### Summary

Nature provides for a balance between sediment transport and physical stream geometry. Alterations to the existing conditions will result in shifts back towards an equilibrium condition. Introduction of physical works within the stream and alteration of the sediment yield characteristics of the watershed will cause adjustments in the stream regime that can be of considerable economic importance and directly affect the cost and value of a proposed water resources program.

Careful attention to the integrated nature of the physical river system in terms of streamflow and sediment transport is an important technical aspect of planning studies concerned with management of natural stream systems.

QUESTIONS  
CHAPTER 15  
SEDIMENT TRANSPORT IN NATURAL STREAMS

1. Can the sediment balancing nature of streams to be used to advantage in projects? If no name some and discuss the means.
2. Describe the potential general effect on the main stream of providing storage on a tributary.
3. What would be the effect of a channel enlargement project on the sediment regime upstream and downstream and within the affected reach? What would be the hydraulic affect?
4. What is the physical principle that causes streams to seek an equilibrium condition? Discuss.

DISCUSSION OF QUESTIONS  
CHAPTER 15  
SEDIMENT TRANSPORT IN NATURAL STREAMS

1. Yes, the relative sediment transport capacity of streams (and portions of streams) is commonly used for beneficial purposes such as in use of wing dams and other deflectors that increase velocities to keep navigation channels open, and channel spreading to encourage deposition for quarry use.
  
2. Storage on a tributary will trap sediment and alter the timing of downstream flows. Assuming flood control storage, the flows will be withheld during the main stem high flow releases made during lower flows. If sediment transport is presently in balance, there will probably be a tendency for the stream channel below the tributary to aggrade and reduce the flow area.
  
3. The hydraulic effect would be similar to that discussed in question 2 of Chapter 13 - clearing and snagging. The general sediment regime effect could be to increase scouring in reaches above and within the enlarged reaches (increased velocities) and deposition within and below the lower reaches of the enlarged section.
  
4. The principle involved is achievement of an overall energy equilibrium in the flow that is related to the sediment transport rate and particle size and water discharge and rate of energy loss.

## FREQUENCY ANALYSIS

CHAPTER 16  
INTRODUCTION TO FREQUENCY ANALYSIS

General Concept

Planning of water resource development involves many kinds of uncertainty. The most fundamental one is the uncertainty of the availability of the water resource itself. Phenomena such as rainfall, streamflow, and lake elevation vary from day to day, month to month and year to year. This variability, over both time and space, is the basis for what hydrologists term frequency analysis. The purpose of such an analysis is to use past records to develop information about the expected future occurrence of certain magnitudes of the various hydrologic phenomena. That is, given the variability of the phenomena in the past, what can we say about expected magnitudes of the phenomena occurring in the future? In addition, the planner is particularly interested in how proposed or anticipated development might change the frequency of certain events. Given this task the hydrologist sets about applying statistical principles to the recorded data.

Recorded Data

Statistical Analysis

Collect recorded data  
Check record  
Extend and complete the record

Develop frequency distributions  
Determine statistical reliability  
Evaluate development effects on  
flow-frequency curves

Natural Phenomena

Frequency analyses have been made for a wide variety of hydrologic phenomena, for example,

- o Annual flood flow peaks
- o Annual flood flow volumes
- o Partial duration flood flow peaks
- o Annual low flow streamflow

- o Low flow volumes
- o Precipitation of various durations
- o Hurricane and magnitudes
- o Annual sediment load
- o River stage and reservoir pool elevation

Generally, frequency analyses of flood flow events are the most common type encountered by planners in the Corps. For this reason the emphasis in the chapters which follow will be in this area.

### Terminology

Probability - "the relative frequency of the occurrence of an event based on the ratio between its occurrence and the total average number of cases necessary to insure its occurrence when such cases are viewed indefinitely extended" (Webster's Unabridged Dictionary). The key characteristic of this term is that it is a relative value, i.e., the number of occurrences is divided by the total number possible. For example, in tossing a die, the probability of throwing a 6 is 1/6. All possible outcomes are known 1, 2, . . . 6 and the relative frequency is 1 in 6. In most water resources literature this definition is not strictly held and the word is used interchangeably with frequency.

Frequency - the number of occurrences which are expected to occur out of some total number possible. Note that it is the number of occurrences, not the ratio of the number and the total number. As an example, the exceedance frequency of a flood of 10,000 cfs may be 10 times in 100 years.

Parent population - the set of all possible random and homogeneous values of the phenomena. For streamflow it would be all possible magnitudes of streamflow, at the location, over history - recorded or not.

Homogeneous - all events occur under the same general conditions. For example, streamflow at a location before and after construction of a reservoir upstream would not be homogeneous. Streamflows caused by a rain storm and by a hurricane would not be homogeneous. Streamflow caused by rainfall and snowmelt are sometimes assumed not to be homogeneous.

Random - whether a particular event occurs or does not occur at a given time must be completely a matter of chance. Regulated streamflow would not be random. Rainfall is considered random.

### Frequency Distribution

As the name implies a frequency distribution is a distribution, tabular or graphical, of the frequency of occurrence of a particular phenomenon. Figure 16.1 (taken from Inter-Agency Committee on Water Resources [5]) shows a histogram, which is a common way of expressing the number of events of a particular magnitude or within a range of magnitudes. The horizontal axis could be magnitude of streamflows and the vertical axis the number of values within a range of magnitudes for the set of recorded data. Since the histogram represents only a sample, and not the parent population, its distribution is only for that sample. The distribution for the parent population is commonly assumed to be that of a smooth curve, shown in Figure 16.1 as the density curve or normal distribution curve.

Figure 16.2 (taken from Inter-Agency Committee on Water Resources [5]) is a graphical representation of the cumulative frequency values (cumulative values of the density curve in Figure 16.1). The scales to the right show these cumulative values as a percentage ( $15/30 \times 100 = 50\%$ ) and as a probability. Note that both scales are arithmetic.

### Normal Distribution

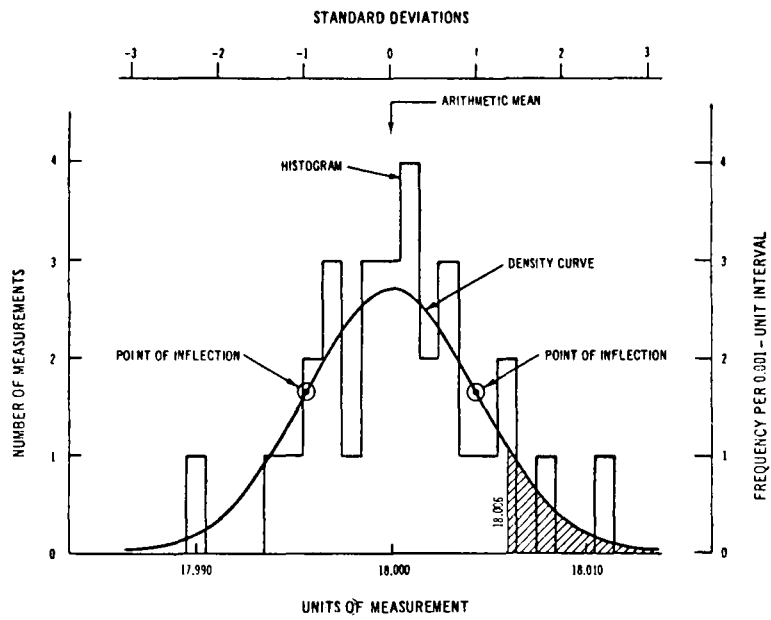
There are two basic statistics which define the shape of the normal distribution curve: mean and standard deviation. These are defined mathematically as:

$$\text{mean} = \bar{X} = \frac{\sum X}{N}$$

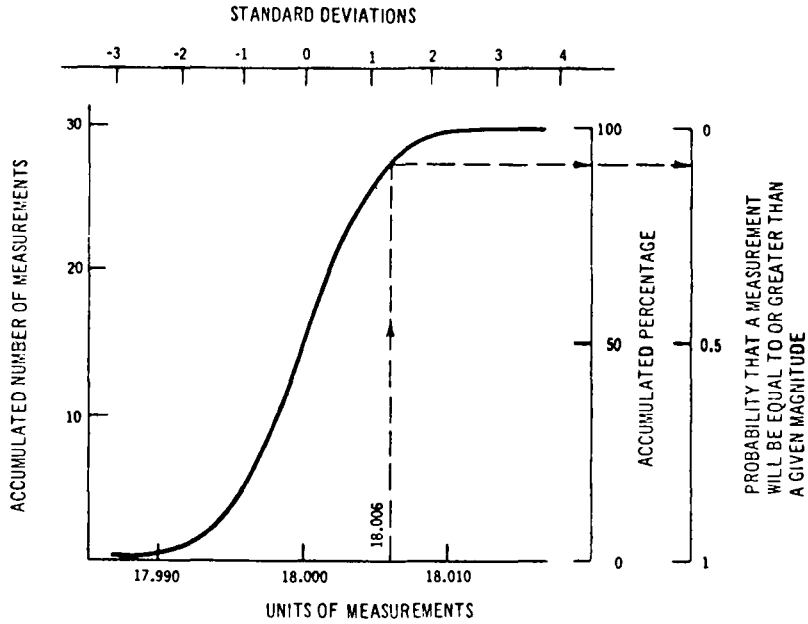
$$\text{standard deviation} = S = \left[ \frac{\sum (X - \bar{X})^2}{N-1} \right]^{.5}$$

$$\text{or} \quad S = \left[ \frac{(\sum X^2) - (\sum X)^2/N}{N-1} \right]^{.5}$$

where,  $X$  = an observed value  
 $N$  = number of observed values



**Figure 16.1 NORMAL DISTRIBUTION CURVE**



**Figure 16.2 CUMULATIVE FREQUENCY CURVE**



Graphically, a change in the mean value translates the normal distribution function laterally along the horizontal axes (see Figure 16.3). A change in mean could occur if additional data were collected.

Changes in the standard deviation modify the shape of the distribution function (see Figures 16.4 and 16.5, taken from Inter-Agency Committee on Water Resources [5]). Note that Figure 16.5 is the same type of curves as Figure 16.2 - magnitude vs probability - and note also that both scales are arithmetic.

Arithmetic - normal probability paper is designed in a way that a normal distribution will plot as a straight line, defined only by its mean and standard deviation values. This is important because by simply computing the mean and standard deviation from recorded data a frequency distribution can be plotted as a straight line.

### Interpretation of the Frequency Distribution

Planners frequently encounter the graphical representation of the frequency distribution shown in Figure 16.6 (taken from Inter-Agency Committee on Water Resources [5]). The horizontal scale represents the frequency of occurrence and is often labeled in a variety of ways:

- o exceedance frequency - the number of times an event of a given magnitude will be exceeded out of some total number, e.g., 50 times per 100 years.
- o exceedance probability - probability expressed in decimal terms, e.g., .01 for an event of 1 in 100 years.
- o percent chance - exceedance probability expressed in a percent form, e.g., 1% has a probability of .01 and frequency of 1 per 100 years.
- o Recurrence interval, exceedance interval, or return period - the number of years, on the average, during which an event is expected to be exceeded, e.g., 50-year recurrence interval.

In the past it was common practice to use the term "equaled or exceeded" with exceedance frequency. In recent years it was pointed out that this is

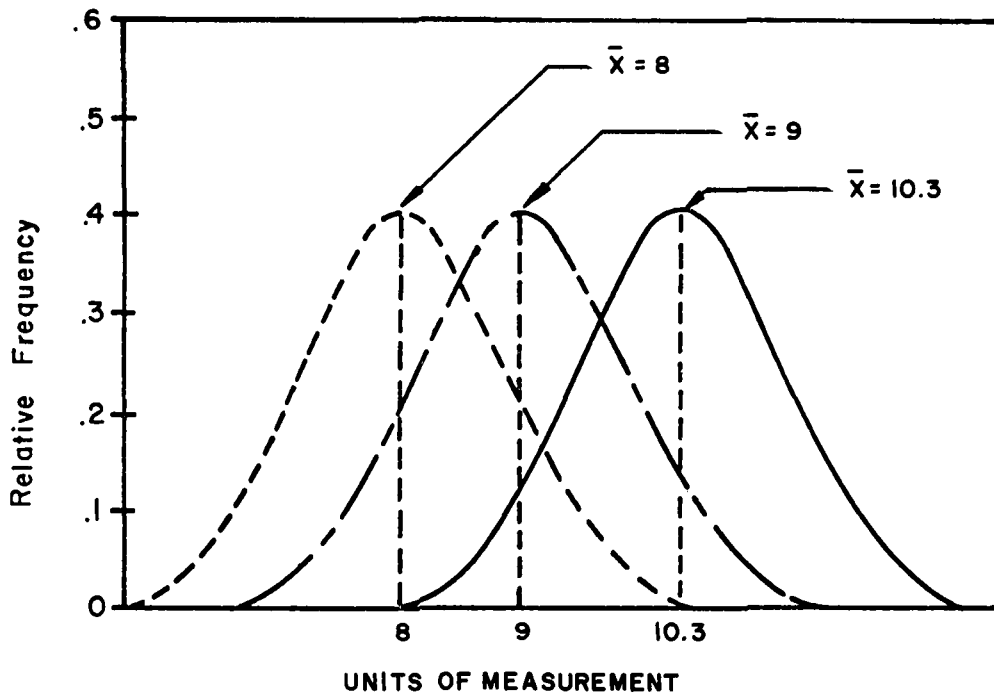


Figure 16.3 NORMAL DISTRIBUTION CURVES WITH DIFFERENT MEANS

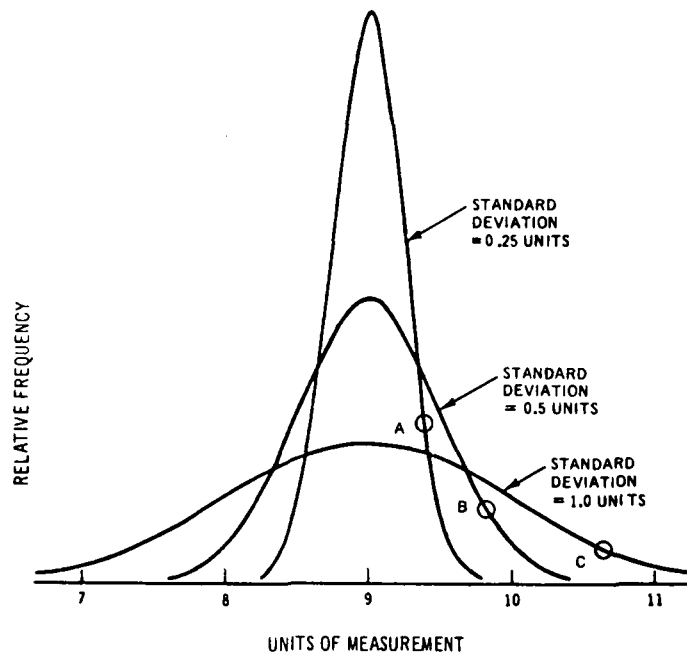
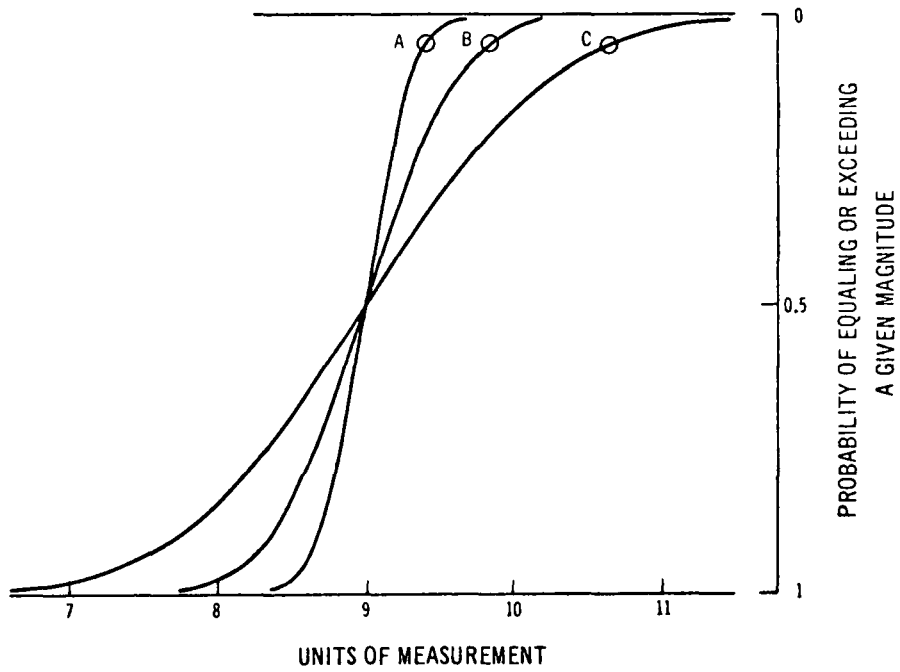
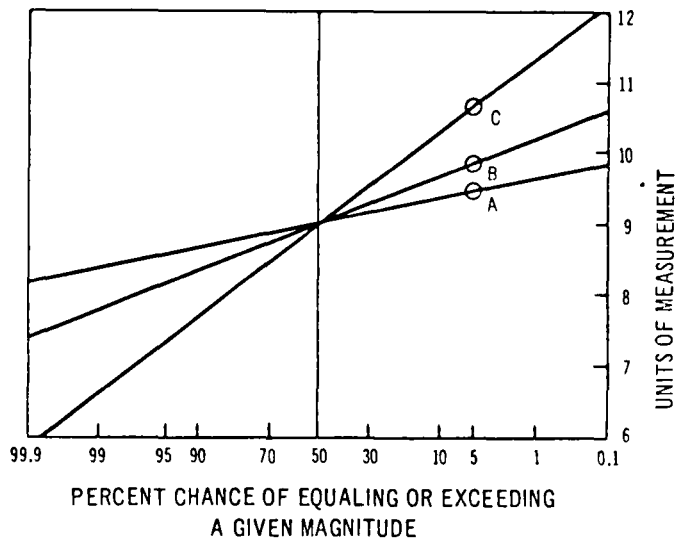


Figure 16.4 NORMAL DISTRIBUTION CURVES WITH DIFFERENT STANDARD DEVIATIONS



**Figure 16.5 CUMULATIVE FREQUENCY CURVES WITH DIFFERENT STANDARD DEVIATIONS**



**Figure 16.6 CUMULATIVE FREQUENCY CURVES WITH DIFFERENT STANDARD DEVIATIONS ON PROBABILITY PAPER**

technically incorrect for continuous distributions (such as streamflow) because the probability of equaling a specific value approaches zero (probability  $1/N$  approaches zero) as  $N$  gets large. The present practice is to use only the term "exceeded". For discrete integer distributions, for example tossing a die, "equaled or exceeded" is appropriate.

In Figure 16.6, for example, 9.3 units are expected to be exceeded in 10 percent of the events sampled, on the average. "On the average" is a necessary part of the interpretation because the frequency is intended to apply to the parent population. Thus, given all events occurring, on the average 10 percent will be equal or greater than 9.3. The sequence of the occurrence is not known.

An important characteristic of the frequency distribution as represented by Figure 16.6 is that the average expected value may be determined by integrating or finding the area beneath the curve. In essence this is the same as weighting each value according to its probability of occurrence. The summation or weighted total is the average value. This characteristic has important application when computing average damages as discussed in Chapter 23.

QUESTIONS  
CHAPTER 16  
INTRODUCTION TO FREQUENCY ANALYSIS

1. In frequency analysis of streamflow, what does a 30-year record represent?
2. What is a frequency distribution?
3. What is a normal distribution? How is it used in frequency analysis?
4. What does it mean to say that there is a 50 percent chance a value will be exceeded?

DISCUSSION TO QUESTIONS  
CHAPTER 16  
INTRODUCTION TO FREQUENCY ANALYSIS

1. A sample set of the parent population of streamflow at a specific location.
2. A distribution of the frequency of occurrence of a particular phenomena.
3. A normal distribution is a particular mathematically-derived distribution of occurrence of events which is sometimes used to represent the expected distribution of hydrologic phenomena.
4. Based upon the sample taken, it can be expected that the value will be exceeded, on the average, 50 percent of the time.

## CHAPTER 17

### DATA COLLECTION AND EVALUATION

#### Introduction

This chapter will discuss the data upon which a frequency analysis is based. It is important to develop as complete and accurate a set as possible to obtain a reliable frequency curve. First, all available information should be used. This includes streamflow records, historic data, data from similar watersheds and flood estimates from precipitation data. Second, the circumstances under which the data were developed should be compared with the requirements for a statistical analysis. Third, and last, the data should be completed and extended using other pertinent information. The purpose of these steps is to improve the reliability of the frequency curve and thus the reliability of the analysis which utilizes the curve.

#### Data Sources

In general, there are four types of data which are used in developing the data set:

- o streamflow records
- o historic data
- o data from similar watersheds
- o precipitation data

Streamflow records are the primary basis of the frequency analysis and originate from gage records at specific stream sites. These data are available from data collection agencies, such as the USGS. Historic data comes from sources other than gages and are useful for making estimates of river stages. These historic data include markings on bridges and buildings, community experience, and other reports and observations. Comparisons between frequency curves and stream gage data in hydrologically similar watersheds are useful for identification of unusual events and for testing the reasonableness of flood flow-frequency determinations. Methods to promote regional consistency are discussed in detail in Chapter 21.

Precipitation data can be converted to streamflow using a calibrated watershed model and the results compared with streamflow records. This type of comparison is useful for identifying inconsistencies in streamflow records.

### Data Assumptions

A necessary assumption for a statistical analysis is that the array of flood information is a reliable and representative sample in time of random homogeneous events.

The following factors can affect these assumptions.

- o climatic trends
- o randomness of events
- o watershed changes
- o mixed populations
- o reliability of flow estimates

Climatic Trends: In hydrologic analysis it is conventional to assume flood flows are not affected by climatic trends (long-term weather changes) because the time scales involved in such trends is thought to be thousands of years.

Randomness of Events: An array of annual maximum peak flows may be considered a sample of random and independent events. This may not be true for low flow data where relatively minor basin development and other factors play a more important role as discussed in WRC [3].

Watershed Changes: Flow conditions can change because of urbanization, channelization, levees, reservoirs, diversions. Watershed history and flood records should be carefully examined to assure that no major watershed changes have occurred during the period-of-record or that the record has been adjusted to account for changes where they have occurred.

Mixed Populations: When records include data from different hydrologic events, e.g., rainstorms, snowmelt and hurricanes, such a record should be



segregated and different flood-frequency curves developed for each type of event. Techniques for this are described in WRC [3].

Reliability of Flow Estimates: The effects of measurement errors may normally be neglected in flood flow-frequency analysis because the errors are usually random, and the variance introduced is usually small in comparison to the year-to-year variance in flood flows.

### Data Adjustments

In addition to the need to consider all available data and check several basic assumptions, it is often necessary to make adjustments to the data array itself. This is necessary for a variety of reasons.

Broken Record: A broken record refers to a record in which several years of annual peaks may be missing because of conditions such as gage removal (perhaps caused by a major flood). In this case, the different record segments are analyzed as a continuous record with length equal to the sum of the lengths of each record (that is, record length = total record - missing years).

Incomplete Record: An incomplete record refers to one in which some peak flows are missing because they were too low or too high to record. Where possible, missing high values should be estimated from historic information. Missing low values can be adjusted by the procedures outlined in WRC [3].

Zero Flood Years: Records of streams in arid regions sometimes have zero flood values for an entire water year. These zero values may be handled by using probability calculations as described in WRC [3].

Outliers: Outliers are data points which depart significantly from the trend of the data, e.g., very high or very low values. Techniques for treating outliers require judgment involving both mathematical and hydrologic considerations and are discussed more fully in WRC [3].

Length of Record: The longer the record, the greater the size of the sample of the parent population, and normally the more reliable the frequency curve. WRC [3] shows information on the data needs for various lengths of records.

QUESTIONS  
CHAPTER 17  
DATA COLLECTION AND EVALUATION

1. What does the data set used in frequency analysis represent?
2. What does a "reliable" and "representative" sample of events mean?
3. What is an example of a nonrandom event?
4. What is an example of a nonhomogeneous data set?
5. What is the purpose of adjusting the data set to account for missing events, broken records, zero values and outliers?

DISCUSSION OF QUESTIONS  
CHAPTER 17  
DATA COLLECTION AND EVALUATION

1. A sample of the parent population.
2. Reliable means accurate and dependable data. Representative means an adequate length of record of the phenomena being measured.
3. Regulated streamflow.
4. Rainstorm data plus hurricane data.
5. To take advantage of information at nearby locations and make the data set as complete and accurate as possible.

## CHAPTER 18

### DETERMINATION OF FLOOD FLOW FREQUENCY CURVES

#### Introduction

As discussed in Chapter 16, a frequency curve is a graphical representation of the frequency with which events of various magnitudes are expected to occur. It is based upon a sample record of past events which are assumed to have the same frequency distribution as the parent population. In Chapter 17 the sample record was discussed and various ways were suggested to improve its completeness and reliability. Having collected and evaluated the data, the next task is to develop the frequency curve which is the subject of this chapter. While there are many different methods for doing this, the work of the U. S. Water Resources Council over the past few years has led to the adoption of one approach by all Federal agencies. This analytical approach referred to as log-Pearson Type III has been found to be applicable to flood flows and various other hydrologic phenomena. In order to visually compare the frequency curve developed analytically with the data, it is always recommended that the data be plotted. This is the simplest method of evaluating whether or not the assumed distribution is consistent with the observed data. A graphical plot is a generally applicable technique and may be the basis for developing relationships where the data are too irregular to fit an analytical distribution.

#### Plotting Frequency Data

The graphical method is relatively simple,

- o Array the frequency data in decreasing order of magnitude (highest value first, second highest second, etc.).
- o Assign plotting positions to each value of frequency data (Use the Table on page E-1 of HEC [4] and included in the attached example as Exhibit 1).
- o Plot the data on logarithmic - probability paper

In Chapter 16 exceedance probability values were computed for the example by dividing a particular number of occurrences by the total ( $m/n$ ).

This assumes the total is in fact the parent population. For hydrologic phenomena only a sample of the parent population is known, thus an adjustment is often made in the plotting position formula to account for the use of the sample instead of the parent population. A variety of plotting position formulas have been developed; the one on which Exhibit 1 is based is used extensively by the Corps of Engineers.  $P = 1 - (.5)^{1/n}$  is used for the largest event,  $P = (.5)^{1/n}$  for the smallest, and  $P$  for all other events are interpolated linearly between these two. It should be noted that the graphical approach makes no assumption regarding the distribution of the data.

### Fitting Data Analytically

Considerable work has been undertaken by the Water Resources Council to find a statistically known frequency distribution that best fits flood flow data. The method decided upon and adopted for use by all Federal agencies is called the log-Pearson Type III method and is discussed by the Inter-Agency Committee on Water Resources [5] and in WRC [3]. A summary of the method is presented below.

Data Transformation: It has been found that by transforming frequency data to logarithms, the data conforms more nearly to the normal distribution which is a known, easily handled distribution. This transformation means simply taking the logarithm (base 10) of each streamflow value for use in all subsequent calculations. Graphically this transformation may be made by plotting the values of streamflow on a logarithmic scale. It will be mentioned here and discussed in more detail later that the log-Pearson Type III distribution with zero skew is the same as the normal distribution.

Log-Pearson Type III Distribution: The log-Pearson Type III distribution is fitted to the recorded data using the relationship:

$$\text{Log } Q = \bar{X} + KS$$

where,  $\log Q$  = logarithm of discharge to base 10

$\bar{X}$  = Mean of the logarithms of the recorded data

$K$  = Pearson Type III deviate. A function of the skew coefficient and selected exceedance probability.

Obtained from WRC [3]

$S$  = Standard deviation of the logarithms of the recorded data

$N$  = Number of items in the data set

$G$  = Skew coefficient of logarithms

and where,

$$\bar{X} = \frac{\sum X}{N}$$

$$S = \left[ \frac{\sum (X - \bar{X})^2}{(N-1)} \right]^{0.5}$$

or

$$S = \left[ \frac{(\sum X^2) - (\sum X)^2/N}{(N-1)} \right]^{0.5}$$

$$G = \frac{N \sum (X - \bar{X})^3}{(N-1)(N-2) S^3}$$

or

$$G = \frac{N^2 (\sum X^3) - 3N(\sum X)(\sum X^2) + 2(\sum X)^3}{N(N-1)(N-2) S^3}$$

The mean, standard deviation, and skew are computed from the logarithmic values of the recorded data. A range of exceedance probability values are selected with sufficient range and detail to define the frequency curve. Then, using the skew coefficient and each exceedance probability, a  $K$  value is selected from WRC [3]. Using the above relationship the logarithm of discharge is computed for each exceedance probability. The anti-log of each  $\log Q$  value is computed and the resulting  $Q$  and exceedance probability values are plotted on logarithmic-probability paper to obtain the graphical representation of the frequency curve.

## Evaluation of Plotted and Fitted Frequency Curves

In most cases a frequency curve will be developed analytically, plotted, and compared with the frequency data. In some instances they may not compare favorably. When this occurs several adjustments may be made to the analytic curve. Historic data may be used, data from similiar watersheds may be compared, floods may be estimated from rainfall records, and the skew coefficient may be adjusted. While the skew is computed analytically using frequency data, it is recognized that it is a highly unstable, unreliable statistic. For this reason the hydrologist often uses regional skew coefficients. An explanation of the skew coefficient follows below.

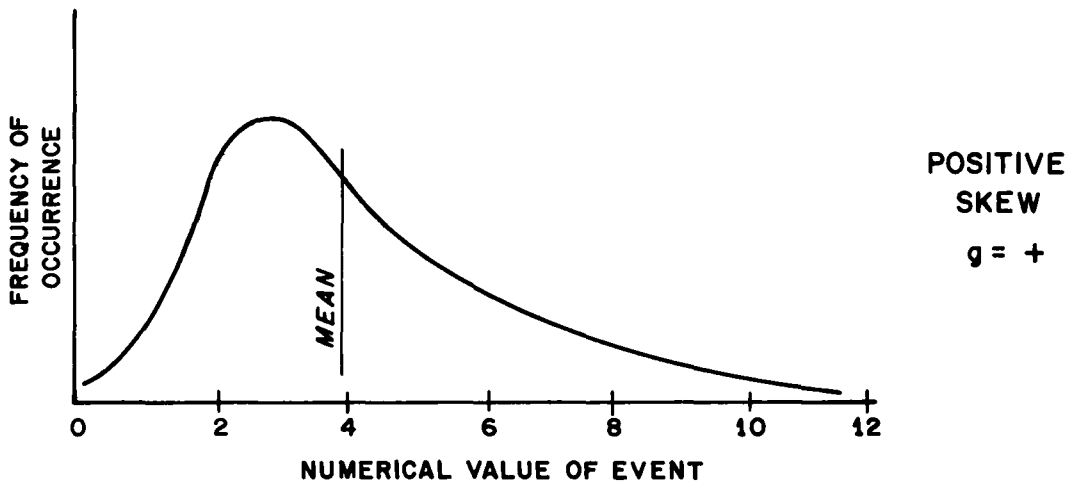
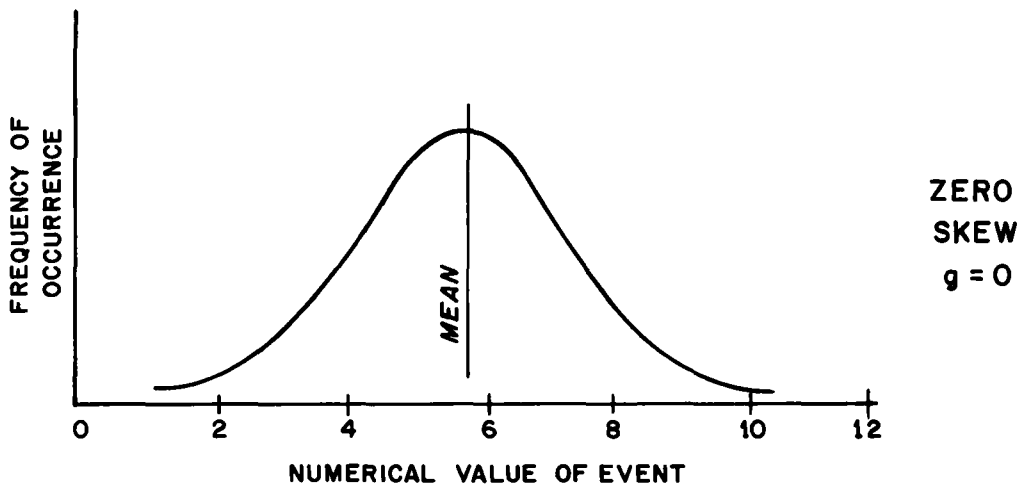
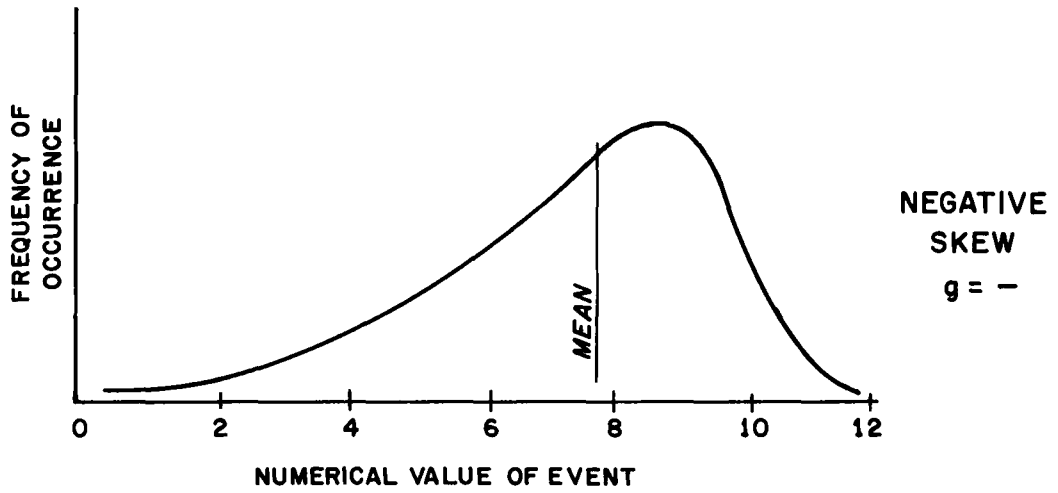
Skew Coefficient: Figure 18.1 shows the influence of the skew coefficient on a frequency distribution. Data which tails to the left (that is, has a few very low values) would show a negative skew, data which tails to the right (has a few very high values) has a positive skew, and data whose distribution is symmetrical, a zero skew. Figure 18.2 shows how various skew values plot on a logarithmic-probability grid.

The skew coefficient of a single station is unreliable because of its sensitivity to extreme events. In addition, it is difficult to obtain an accurate estimate with small samples. As the size of the sample (length of record) increases, the skew is generally more reliable. Thus it is common practice to use regionalized or generalized coefficients instead of computed skews based on short records. For generalized values the skew is weighted according to length of record as discussed in WRC [3].

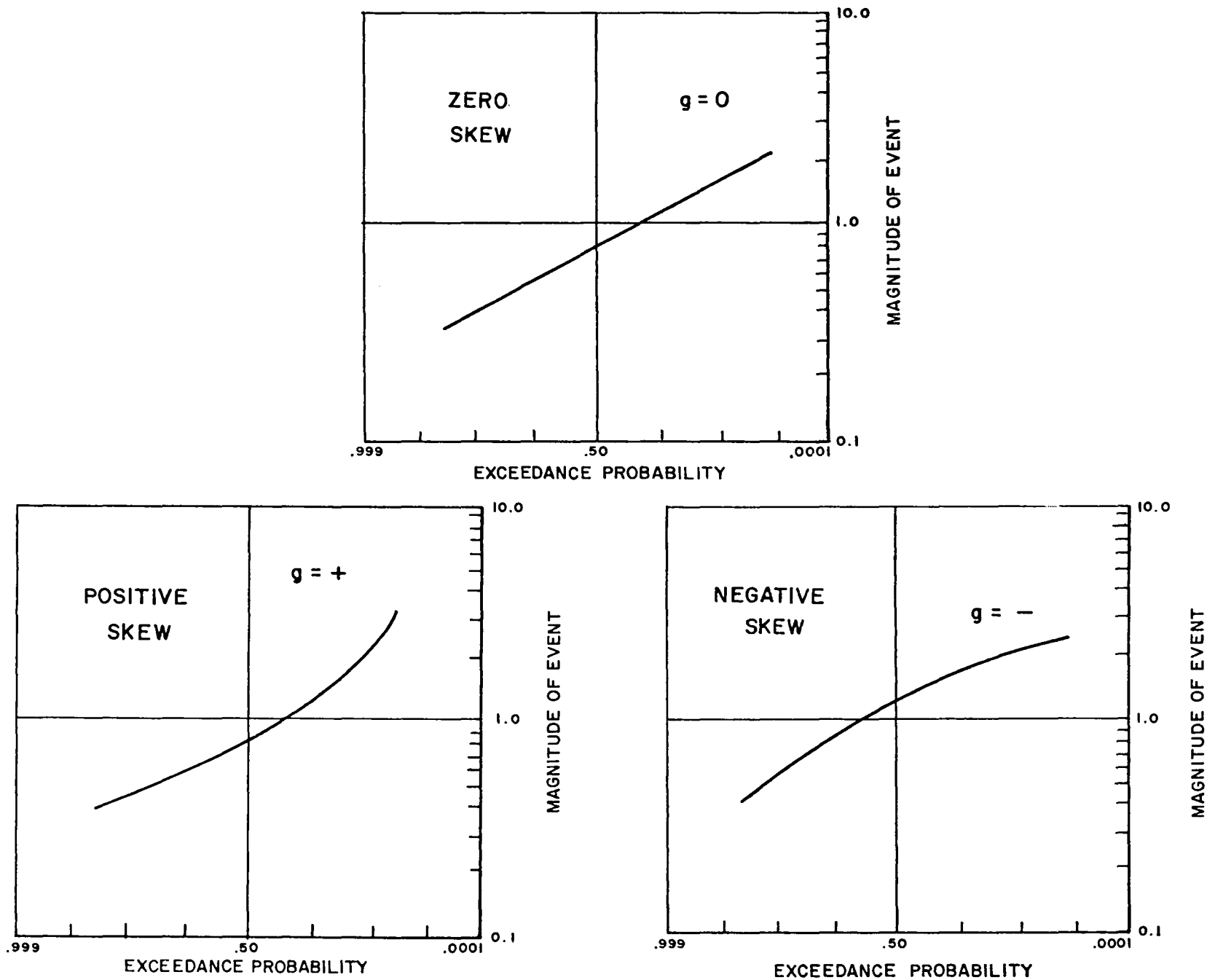
Some physical, geographic features which affect the skew coefficients are:

- o A watershed with a sizeable percentage of its area in lakes or ponds (negative skew)
- o An extremely wide flood plain relative to the volume of flow (negative skew)
- o A basin which is shaped such that the peak from two or more tributaries may arrive at the confluence at the same time (positive skew)





**Figure 18.1 INFLUENCE OF SKEW ON FREQUENCY DISTRIBUTION**



**Figure 18.2 INFLUENCE OF SKEW ON CUMULATIVE FREQUENCY CURVE**

A generalized skew coefficient is usually determined in the following manner:

- o Compute the skew coefficient for the frequency data
- o Develop a generalized skew coefficient by weighting the skew values obtained from streamflow records over a large region
- o Compute the frequency curve using the generalized values and compare it with the plotted data

EXAMPLE  
GRAPHICAL FREQUENCY COMPUTATIONS

An illustrative example of the graphical method of developing flow frequency curves is shown in Figure 18.3 and 18.4 (See pages 4-03 and 4-05 of HEC [4]). The method is described below.

Column

- 1        The water year is October 1 to September 30, thus in the first line October 1928 to September 30, 1929.
  
- 2        This is the date, during the water year, on which the maximum or other flow over 3,000 cfs occurred. The other flows are used in the partial duration series, columns 9-12.
  
- 3        In line 1 the flow 1,520 cfs is the maximum flow during the water year October 1928 to October 1929. It occurred on 3 February. Some years have several values tabulated, e.g., 1934-35. The 4 January value is the maximum for the year. The other two values are flows over 3,000 cfs and are used in the partial duration series calculations.
  
- 4,5,6    These are similar data to those in columns 1,2,3 and cover the period 1943 through 1958.
  
- 8        These are the annual maximum flows tabulated from the highest value in decreasing order. They were identified by scanning the data tabulated in columns 3 and 6. Note that the other flows tabulated for some years were not considered, only the maximum each year.
  
- 7        There are 30 annual maximum values tabulated in Column 8. Referring to Exhibit 1, sheets 1 and 2 from HEC [4], we find the plotting positions for each value  $N=30$ ,  $m=1,2...30$ . These are the values tabulated in this column.

Having determined the plotting position for each annual maximum flow, it is now only necessary to plot these data on graph paper. The plotting grid commonly used is the logarithmic-probability grid. The flow values are plotted on the vertical, logarithmic scale; and the plotting positions, which are the frequency values, are plotted on the probability scale (horizontal axis). By plotting flow values on a logarithmic scale the data is essentially transformed to logarithms. As pointed out earlier, if the data is normally distributed it will plot as a straight line on this grid. Figure 18.4 is a plot of the data in columns 7 and 8. The line through the data is a graphical, i.e., judgmental fit of these data.

**ILLUSTRATIVE EXAMPLE**

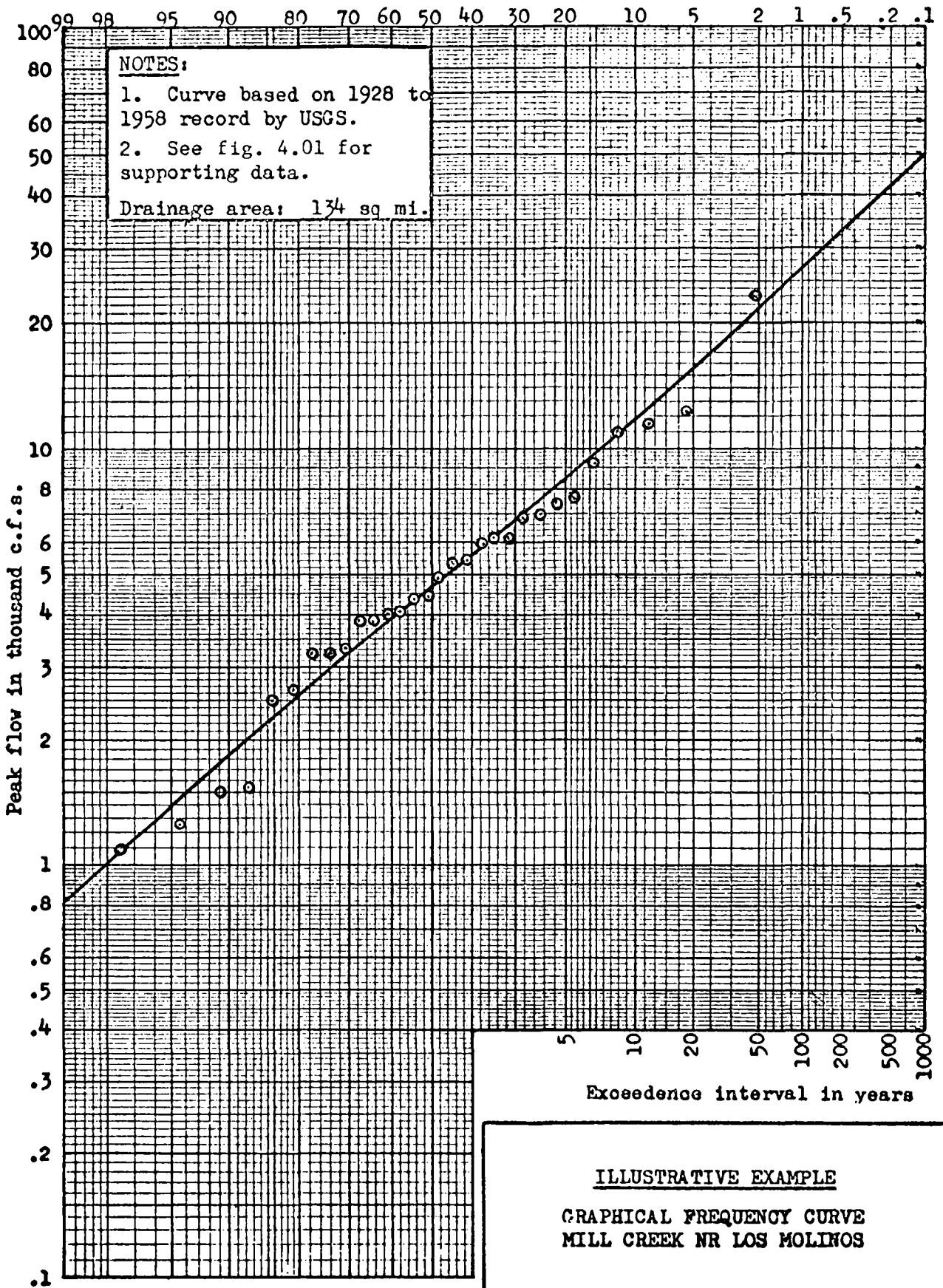
**TABULATION OF PEAK-FLOW FREQUENCY DATA  
MILL CREEK NEAR LOS MOLINOS, CALIFORNIA**

Events in order recorded						Events in decreasing order of magnitude					
Annual maximum, and all other flows above 3000 c.f.s. and separated by 10 days or more from larger flows						Annual Maximum		Partial-duration series (flows above 3000 c.f.s.)			
Water Year (1)	Date (2)	Flow (cfs) (3)	Water Year (4)	Date (5)	Flow (cfs) (6)	Plotting Position (7)	Flow (cfs) (8)	Plotting Position (9)	Flow (cfs) (10)	Plotting Position (11)	Flow (cfs) (12)
1928-29	3 Feb	1,520	1943-44	4 Mar	3,220	2.3	23,000	2.3	23,000	91.7	4,650
1929-30	15 Dec	6,000	1944-45	5 Feb	3,230	5.6	12,200	5.6	12,200	95.0	4,600
1930-31	23 Jan	1,500	1945-46	4 Dec	3,660	8.9	11,400	8.9	11,400	98.3	4,540
1931-32	24 Dec	5,440	1945-46	21 Dec	6,180	12.2	11,000	12.2	11,000	101.7	4,430
1932-33	16 Mar	1,080	1946-47	12 Feb	4,070	15.4	9,180	15.4	9,360	105.0	4,380
1933-34	29 Dec	2,630	1947-48	23 Mar	7,320	18.7	7,710	18.7	9,180	108.3	4,330
1934-35	4 Jan	4,010	1947-48	28 Apr	3,380	22.0	7,320	22.0	7,710	111.7	4,250
1934-35	28 Feb	3,190	1948-49	11 Mar	3,870	25.3	6,970	25.3	7,320	115.0	4,240
1934-35	8 Apr	3,040	1949-50	4 Feb	4,430	28.6	6,880	28.6	7,260	118.3	4,130
1935-36	11 Jan	3,930	1950-51	16 Nov	3,870	31.9	6,180	31.9	6,970	121.7	4,070
1935-36	21 Feb	4,380	1950-51	22 Jan	3,510	35.2	6,140	35.2	6,910	125.0	4,010
1936-37	14 Feb	3,310	1950-51	11 Feb	3,660	38.5	6,000	38.5	6,880	128.3	3,970
1937-38	20 Nov	4,700	1951-52	1 Dec	4,930	41.8	5,440	41.8	6,480	131.7	3,930
1937-38	11 Dec	23,000	1951-52	26 Dec	5,280	45.1	5,280	45.1	6,450	135.0	3,870
1937-38	2 Feb	5,050	1951-52	1 Feb	4,650	48.4	4,910	48.4	6,240	138.3	3,870
1937-38	23 Mar	4,950	1952-53	9 Jan	7,710	51.6	4,430	51.7	6,180	141.7	3,660
1938-39	8 Mar	1,260	1952-53	27 Apr	3,070	54.9	4,380	55.0	6,140	145.0	3,660
1939-40	2 Jan	4,600	1952-53	17 Jan	4,910	58.2	4,070	58.3	6,000	148.3	3,510
1939-40	28 Feb	11,400	1953-54	13 Feb	3,300	61.5	4,010	61.7	5,450	151.7	3,380
1939-40	30 Mar	9,360	1953-54	4 Apr	4,240	64.8	3,870	65.0	5,440	155.0	3,310
1940-41	24 Dec	6,240	1954-55	11 Nov	2,480	68.1	3,870	68.3	5,280	158.3	3,300
1940-41	10 Feb	12,200	1955-56	22 Dec	9,180	71.4	3,310	71.7	5,050	161.7	3,230
1940-41	1 Mar	4,250	1955-56	7 Jan	5,020	74.7	3,230	75.0	5,020	165.0	3,220
1940-41	4 Apr	7,260	1955-56	22 Feb	6,480	78.0	3,220	78.3	4,950	168.3	3,190
1941-42	3 Dec	4,130	1956-57	24 Feb	6,140	81.3	2,630	81.7	4,930	171.7	3,070
1941-42	16 Dec	6,910	1957-58	26 Jan	3,060	84.6	2,480	85.0	4,910	175.0	3,060
1941-42	27 Jan	5,450	1957-58	12 Feb	4,330	87.8	1,520	88.3	4,700	178.3	3,040
1941-42	6 Feb	11,000	1957-58	24 Feb	6,880	91.1	1,500				
1942-43	21 Jan	6,450	1957-58	21 Mar	4,540	94.4	1,260				
1942-43	8 Mar	6,970	1957-58	2 Apr	3,970	97.7	1,080				

18.10

Figure 18.3

Exceedence frequency per hundred years



ILLUSTRATIVE EXAMPLE  
 GRAPHICAL FREQUENCY CURVE  
 MILL CREEK NR LOS MOLINOS

Figure 18.4

PLOTTING POSITIONS IN PERCENT  
(EXCEEDENCE FREQUENCY IN EVENTS PER HUNDRED YEARS)

m	N	1	2	3	4	5	6	7	8	9	10	11	12	13	14	15	16	17	18	19	20	21	22	N	m				
		50.0	29.3	20.6	15.9	13.0	10.9	9.43	8.30	7.43	6.70	6.11	5.62	5.20	4.83	4.52	4.25	4.00	3.78	3.58	3.41	3.25	3.10		1				
			70.7	50.0	38.6	31.5	26.5	22.9	20.2	18.1	16.3	14.9	13.7	12.7	11.8	11.0	10.3	9.8	9.2	8.8	8.3	7.9	7.6		2				
				79.4	61.4	50.0	42.2	36.5	32.1	28.7	25.9	23.7	21.8	20.1	18.7	17.5	16.4	15.5	14.7	13.9	13.2	12.6	12.0		3				
44		98.4			84.1	68.5	57.8	50.0	44.0	39.4	35.6	32.4	29.8	27.6	25.7	24.0	22.5	21.2	20.1	19.1	18.1	17.3	16.5		4				
43		96.2	98.4			87.0	73.5	63.5	56.0	50.0	45.2	41.2	37.9	35.1	32.6	30.5	28.6	27.0	25.5	24.2	23.0	22.0	21.0		5				
42		93.9	96.1	98.4			89.1	77.1	67.9	60.6	54.8	50.0	46.0	42.5	39.6	37.0	34.7	32.8	31.0	29.4	27.9	26.6	25.4		6				
41		91.7	93.8	96.0	98.3			90.6	79.8	71.3	64.4	58.8	54.0	50.0	46.5	43.5	40.8	38.5	36.4	34.5	32.8	31.3	29.9		7				
40		89.4	91.5	93.6	95.9	98.3			91.7	81.9	74.1	67.6	62.1	57.5	53.5	50.0	46.9	44.2	41.8	39.7	37.7	36.0	34.4		8				
39		87.2	89.2	91.3	93.5	95.8	98.2			92.6	83.7	76.3	70.2	64.9	60.4	56.5	53.1	50.0	47.3	44.8	42.6	40.6	38.8		9				
38		84.9	86.9	88.9	91.1	93.3	95.7	98.2			93.3	85.1	78.2	72.4	67.4	63.0	59.2	55.8	52.7	50.0	47.5	45.3	43.3		10				
37		82.7	84.6	86.6	88.7	90.8	93.2	95.6	98.1			93.9	86.3	79.9	74.3	69.5	65.3	61.5	58.2	55.2	52.5	50.0	47.8		11				
36		80.4	82.3	84.2	86.2	88.4	90.6	93.0	95.5	98.1			94.4	87.3	81.3	76.0	71.4	67.2	63.6	60.3	57.4	54.7	52.2		12				
35		78.2	80.0	81.9	83.8	85.9	88.1	90.4	92.8	95.3	98.0			94.8	88.2	82.5	77.5	73.0	69.0	65.5	62.3	59.4	56.7		13				
34		75.9	77.4	79.5	81.4	83.4	85.5	87.8	90.1	92.6	95.2	98.0			95.2	89.0	83.6	78.8	74.5	70.6	67.2	64.0	61.2		14				
33		73.7	75.4	77.1	79.0	81.0	83.0	85.2	87.4	89.8	92.4	95.1	97.9			95.5	89.7	84.5	79.9	75.8	72.1	68.7	65.6		15				
32		71.4	73.0	74.8	76.6	78.5	80.5	82.6	84.8	87.1	89.6	92.2	94.9	97.9			95.8	90.2	85.3	80.9	77.0	73.4	70.1		16				
31		69.2	70.7	72.4	74.2	76.0	77.9	80.0	82.1	84.3	86.7	89.3	91.9	94.8	97.8			96.0	90.8	86.1	81.9	78.0	74.6		17				
30		66.9	68.4	70.1	71.7	73.5	75.4	77.4	79.4	81.6	83.9	86.3	88.9	91.7	94.6	97.7			96.2	91.2	86.8	82.7	79.0		18				
29		64.6	66.1	67.7	69.3	71.0	72.9	74.7	76.7	78.9	81.1	83.4	85.9	88.6	91.4	94.4	97.6			96.4	91.7	87.4	83.5		19				
28		62.4	63.8	65.3	66.9	68.6	70.3	72.1	74.1	76.1	78.3	80.5	82.9	85.5	88.2	91.1	94.2	97.6			96.6	92.1	88.0		20				
27		60.1	61.5	63.0	64.5	66.1	67.8	69.5	71.4	73.4	75.4	77.6	79.9	82.4	85.0	87.8	90.8	94.1	97.5			96.8	92.4		21				
26		57.9	59.2	60.6	62.1	63.6	65.2	66.9	68.7	70.6	72.6	74.7	77.0	79.3	81.9	84.6	87.4	90.5	93.8	97.4			96.9		22				
25		55.6	56.9	58.3	59.7	61.1	62.7	64.3	66.0	67.9	69.8	71.8	74.0	76.2	78.7	81.3	84.0	87.0	90.2	93.6	97.3				23				
24		53.4	54.6	55.9	57.2	58.7	60.2	61.7	63.4	65.1	67.0	68.9	71.0	73.2	75.5	78.0	80.6	83.5	86.5	89.8	93.3	97.2				24			
23		51.1	52.3	53.5	54.8	56.2	57.6	59.1	60.7	62.4	64.1	66.0	68.0	70.1	72.3	74.7	77.2	80.0	82.9	86.0	89.4	93.0	97.0				25		
22		48.9	50.0	51.2	52.4	53.7	55.1	56.5	58.0	59.6	61.3	63.1	65.0	67.0	69.1	71.4	73.8	76.4	79.2	82.2	85.5	89.0	92.8				26		
21		46.6	47.7	48.8	50.0	51.2	52.5	53.9	55.3	56.9	58.5	60.2	62.0	63.9	65.9	68.1	70.4	72.9	75.6	78.4	81.5	84.8	88.5				27		
20		44.4	45.4	46.5	47.6	48.8	50.0	51.3	52.7	54.1	55.7	57.3	59.0	60.8	62.7	64.8	67.0	69.4	71.9	74.6	77.6	80.8	84.2					28	
19		42.1	43.1	44.1	45.2	46.3	47.5	48.7	50.0	51.4	52.8	54.4	56.0	57.9	59.6	61.5	63.6	65.9	68.3	70.8	73.6	76.6	79.9					29	
18		39.9	40.8	41.7	42.8	43.8	44.9	46.1	47.3	48.6	50.0	51.5	53.0	54.6	56.4	58.2	60.2	62.3	64.6	67.1	69.7	72.6	75.7					30	
17		37.6	38.5	39.4	40.3	41.3	42.4	43.5	44.7	45.9	47.2	48.5	50.0	51.5	53.2	54.9	56.8	58.8	61.0	63.3	65.8	68.4	71.4					31	
16		35.4	36.2	37.0	37.9	38.9	39.8	40.9	42.0	43.1	44.3	45.6	47.0	48.5	50.0	51.6	53.4	55.3	57.3	59.5	61.8	64.4	67.1					32	
15		33.1	33.9	34.7	35.5	36.4	37.3	38.3	39.3	40.4	41.5	42.7	44.0	45.4	46.8	48.4	50.0	51.8	53.7	55.7	57.9	60.2	62.8					33	
14		30.8	31.6	32.3	33.1	33.9	34.8	35.7	36.6	37.6	38.7	39.8	41.0	42.1	43.6	45.1	46.6	48.2	50.0	51.9	53.9	56.2	58.6					34	
13		28.6	29.3	29.9	30.7	31.4	32.2	33.1	34.0	34.9	35.9	36.9	38.0	39.2	40.4	41.8	43.2	44.7	46.3	48.1	50.0	52.0	54.3					35	
12		26.3	27.0	27.6	28.3	29.0	29.7	30.5	31.3	32.1	33.0	34.0	35.0	36.1	37.3	38.5	39.8	41.2	42.7	44.3	46.1	48.0	50.0					36	
11		24.1	24.6	25.2	25.8	26.5	27.1	27.9	28.6	29.4	30.2	31.1	32.0	33.0	34.1	35.2	36.4	37.7	39.0	40.5	42.1	43.8	45.7					37	
10		21.8	22.3	22.9	23.4	24.0	24.6	25.3	25.9	26.6	27.4	28.2	29.0	29.9	30.9	31.9	33.0	34.1	35.4	36.7	38.2	39.8	41.4					38	
9		19.6	20.0	20.5	21.0	21.5	22.1	22.6	23.3	23.9	24.6	25.3	26.0	26.8	27.7	28.6	29.6	30.6	31.7	32.9	34.2	35.6	37.2					39	
8		17.3	17.7	18.1	18.6	19.0	19.5	20.0	20.6	21.1	21.7	22.4	23.0	23.8	24.5	25.3	26.2	27.1	28.1	29.2	30.3	31.6	32.9					40	
7		15.1	15.4	15.8	16.2	16.6	17.0	17.4	17.9	18.4	18.9	19.5	20.1	20.7	21.3	22.0	22.8	23.6	24.4	25.4	26.4	27.4	28.6					41	
6		12.8	13.1	13.4	13.8	14.1	14.5	14.8	15.2	15.7	16.1	16.6	17.1	17.6	18.1	18.7	19.4	20.0	20.8	21.6	22.4	23.4	24.3					42	
5		10.6	10.8	11.1	11.3	11.6	11.9	12.2	12.6	12.9	13.3	13.7	14.1	14.5	15.0	15.4	16.0	16.5	17.1	17.8	18.5	19.2	20.1					43	
4		8.3	8.5	8.7	8.9	9.2	9.4	9.6	9.9	10.2	10.4	10.7	11.1	11.4	11.8	12.2	12.6	13.0	13.5	14.0	14.5	15.2	15.8					44	
3		6.1	6.2	6.4	6.5	6.7	6.8	7.0	7.2	7.4	7.6	7.8	8.1	8.3	8.6	8.9	9.2	9.5	9.8	10.2	10.6	11.0	11.5					45	
2		3.8	3.9	4.0	4.1	4.2	4.3	4.4	4.5	4.7	4.8	4.9	5.1	5.2	5.4	5.6	5.8	6.0	6.2	6.4	6.7	7.0	7.2					46	
1		1.56	1.60	1.64	1.68	1.72	1.76	1.81	1.86	1.91	1.96	2.02	2.08	2.15	2.22	2.29	2.36	2.45	2.54	2.64	2.74	2.85	2.97					47	
m	N	44	43	42	41	40	39	38	37	36	35	34	33	32	31	30	29	28	27	26	25	24	23					N	m



**PLOTTING POSITIONS IN PERCENT**  
(EXCEEDENCE FREQUENCY IN EVENTS PER HUNDRED YEARS)

m	N	45	46	47	48	49	50	51	52	53	54	55	56	57	58	59	60	61	62	63	64	65	66	N <sub>m</sub>
1		1.53	1.50	1.47	1.43	1.41	1.38	1.35	1.32	1.30	1.28	1.25	1.23	1.21	1.19	1.17	1.15	1.13	1.11	1.09	1.08	1.06	1.05	1
2		3.7	3.7	3.6	3.5	3.4	3.4	3.3	3.2	3.2	3.1	3.1	3.0	3.0	2.9	2.8	2.8	2.7	2.7	2.7	2.6	2.6	2.5	2
3		5.9	5.8	5.7	5.6	5.4	5.3	5.2	5.1	5.0	5.0	4.9	4.8	4.7	4.6	4.5	4.5	4.4	4.3	4.2	4.2	4.1	4.1	3
4		8.1	8.0	7.8	7.6	7.5	7.3	7.2	7.0	6.9	6.8	6.7	6.6	6.4	6.3	6.2	6.1	6.0	5.9	5.8	5.7	5.6	5.6	4
5		10.3	10.1	9.9	9.7	9.5	9.3	9.1	9.0	8.8	8.6	8.5	8.3	8.2	8.0	7.9	7.8	7.6	7.5	7.4	7.3	7.2	7.1	5
6		12.5	12.3	12.0	11.8	11.5	11.3	11.1	10.9	10.7	10.5	10.3	10.1	9.9	9.8	9.6	9.4	9.3	9.1	9.0	8.8	8.7	8.6	6
7		14.7	14.4	14.1	13.8	13.6	13.3	13.1	12.8	12.5	12.3	12.1	11.9	11.7	11.5	11.3	11.1	10.9	10.7	10.6	10.4	10.2	10.1	7
8		17.0	16.7	16.2	15.9	15.6	15.3	15.0	14.7	14.4	14.1	13.9	13.6	13.4	13.2	13.0	12.7	12.5	12.3	12.1	12.0	11.8	11.6	8
9		19.2	18.7	18.3	18.0	17.6	17.2	16.9	16.6	16.3	16.0	15.7	15.4	15.2	14.9	14.6	14.4	14.2	13.9	13.7	13.5	13.3	13.1	9
10		21.4	20.9	20.5	20.0	19.6	19.2	18.9	18.5	18.2	17.8	17.5	17.2	16.9	16.6	16.3	16.1	15.8	15.5	15.3	15.1	14.8	14.6	10
11		23.6	23.1	22.6	22.1	21.6	21.2	20.9	20.4	20.0	19.7	19.3	19.0	18.6	18.3	18.0	17.7	17.4	17.1	16.9	16.6	16.4	16.1	11
12		25.8	25.2	24.7	24.2	23.7	23.2	22.8	22.3	21.9	21.5	21.1	20.7	20.4	20.0	19.7	19.4	19.0	18.7	18.4	18.2	17.9	17.6	12
13		28.0	27.4	26.8	26.2	25.7	25.2	24.7	24.2	23.8	23.3	22.9	22.5	22.1	21.7	21.4	21.0	20.7	20.3	20.0	19.7	19.4	19.1	13
14		30.2	29.5	28.9	28.3	27.7	27.2	26.6	26.1	25.7	25.2	24.7	24.3	23.9	23.5	23.1	22.7	22.3	21.9	21.6	21.3	20.9	20.6	14
15		32.4	31.7	31.0	30.4	29.8	29.2	28.6	28.0	27.5	27.0	26.5	26.1	25.6	25.2	24.7	24.3	23.9	23.6	23.2	22.8	22.5	22.1	15
16		34.6	33.8	33.1	32.4	31.8	31.1	30.5	30.0	29.4	28.9	28.3	27.8	27.3	26.9	26.4	26.0	25.6	25.2	24.8	24.4	24.0	23.6	16
17		36.8	36.0	35.2	34.5	33.8	33.1	32.5	31.9	31.3	30.7	30.1	29.6	29.1	28.6	28.1	27.6	27.2	26.8	26.3	25.9	25.5	25.1	17
18		39.0	38.1	37.3	36.6	35.9	35.1	34.4	33.8	33.1	32.5	31.9	31.4	30.8	30.3	29.8	29.3	28.8	28.4	27.9	27.5	27.1	26.7	18
19		41.2	40.3	39.4	38.6	37.8	37.1	36.4	35.7	35.0	34.4	33.8	33.2	32.6	32.0	31.5	31.0	30.5	30.0	29.5	29.0	28.6	28.2	19
20		43.4	42.5	41.6	40.7	39.9	39.1	38.3	37.6	36.9	36.2	35.6	34.9	34.3	33.7	33.2	32.6	32.1	31.6	31.1	30.6	30.1	29.7	20
21		45.6	44.6	43.7	42.8	41.9	41.1	40.3	39.5	38.8	38.0	37.4	36.7	36.1	35.4	34.8	34.3	33.7	33.2	32.6	32.1	31.6	31.2	21
22		47.8	46.8	45.8	44.8	43.9	43.1	42.2	41.4	40.6	39.9	39.2	38.5	37.8	37.2	36.5	35.9	35.3	34.8	34.2	33.7	33.2	32.7	22
23		50.0	48.9	47.9	46.9	46.0	45.0	44.2	43.3	42.5	41.7	41.0	40.2	39.5	38.9	38.2	37.6	37.0	36.4	35.8	35.2	34.7	34.2	23
				50.0	49.0	48.0	47.0	46.1	45.2	44.4	43.6	42.8	42.0	41.3	40.6	39.9	39.2	38.6	38.0	37.4	36.8	36.2	35.7	24
						50.0	49.0	48.1	47.1	46.3	45.4	44.6	43.8	43.0	42.3	41.6	40.9	40.2	39.6	39.0	38.4	37.8	37.2	25
								50.0	49.0	48.1	47.2	46.4	45.6	44.8	44.0	43.3	42.5	41.9	41.2	40.5	39.9	39.3	38.7	26
										50.0	49.1	48.2	47.3	46.5	45.7	44.9	44.2	43.5	42.8	42.1	41.5	40.8	40.2	27
												50.0	49.1	48.3	47.4	46.6	45.9	45.1	44.4	43.7	43.0	42.4	41.7	28
														50.0	49.1	48.3	47.5	46.7	46.0	45.3	44.6	43.9	43.2	29
																50.0	49.2	48.4	47.6	46.9	46.1	45.4	44.7	30
																		50.0	49.2	48.4	47.7	46.9	46.2	31
																				50.0	49.2	48.5	47.7	32
																						50.0	49.2	33
	N	67	68	69	70	71	72	73	74	75	76	77	78	79	80	81	82	83						N
	P <sub>1</sub>	1.03	1.01	1.00	.99	.97	.96	.94	.93	.92	.91	.90	.88	.87	.86	.85	.84	.83						P <sub>1</sub>
	ΔP	1.4839	1.4624	1.4412	1.4206	1.4008	1.3814	1.3628	1.3444	1.3265	1.3091	1.2921	1.2758	1.2597	1.2440	1.2288	1.2138	1.1993						ΔP
	N	84	85	86	87	88	89	90	91	92	93	94	95	96	97	98	99	100						N
	P <sub>1</sub>	.82	.81	.80	.79	.78	.78	.77	.76	.75	.74	.73	.73	.72	.71	.71	.70	.69						P <sub>1</sub>
	ΔP	1.1851	1.1712	1.1576	1.1444	1.1315	1.1186	1.1063	1.0942	1.0824	1.0709	1.0596	1.0483	1.0375	1.0269	1.0163	1.0061	.9962						ΔP

**NOTES:**

1. Plotting positions are symmetrical about 50 percent.
2. For arrays exceeding 66 values, plotting positions can readily be obtained by use of desk calculator and constants given below.

EXAMPLE  
ANALYTICAL FREQUENCY COMPUTATIONS

An example and explanation of the analytical frequency method is shown in Figure 18.5 (for a detailed explanation see pages 4-08 through 4-15 of HEC [4]). The equations used to complete the frequency curve are shown below:

$$\log Q = \bar{X} + K S$$

where,

$$\bar{X} = \frac{\sum X}{N} = \text{mean value in logarithms}$$

$$x = X - \bar{X} = \text{Deviation from the mean}$$

$$\sum x^2 = \sum X^2 - (\sum X)^2/N$$

$$S = \left[ \frac{(\sum x^2)}{N-1} \right]^{.5} = \text{standard deviation}$$

$K$  = Pearson Type III deviate, obtained from WRC [3]

Knowing  $X$ ,  $K$  and  $S$  for selected values of the exceedance probability the log  $Q$  value can be computed. In WRC [3] and as discussed in Chapter 18, these are the values which are plotted as the frequency curve. HEC [4], however, makes an additional adjustment for the small sample of hydrologic data. This is done by adjusting the exceedance probability referred to as  $P$  (for assumed infinite sample size) using the table on page E-4 from HEC [4]. The resulting frequency values are referred to as expected probability values  $P_N$  (for actual sample size).

Whether the exceedance probability or expected probability are plotted, the last step is to plot the data determined analytically and construct the frequency curve. The basic frequency data should also be plotted for comparison purposes. See the plotting description discussed earlier.

ILLUSTRATIVE EXAMPLE

ANALYTICAL COMPUTATION OF PEAK-FLOW FREQUENCY CURVE  
MILL CREEK NEAR LOS MOLINOS, CALIFORNIA

(1) Water Year	(2) Flow (c.f.s.)	(3) Log (X)	(4) Dev. (x)	(5) $x^2$			
1928-29	1,520	3.18	-.49	.240			
30	6,000	3.78	.11	.012			
31	1,500	3.18	-.49	.240			
32	5,440	3.74	.07	.005			
33	1,080	3.03	-.64	.410			
34	2,630	3.42	-.25	.062			
1934-35	4,010	3.60	-.07	.005			
36	4,380	3.64	-.03	.001			
37	3,310	3.52	-.15	.022			
38	23,000	4.36	.69	.476			
39	1,260	3.10	-.57	.325			
1939-40	11,400	4.06	.39	.152			
41	12,200	4.09	.42	.176			
42	11,000	4.04	.37	.137			
43	6,970	3.84	.17	.029			
44	3,220	3.51	-.16	.026			
1944-45	3,230	3.51	-.16	.026			
46	6,180	3.79	.12	.014			
47	4,070	3.61	.06	.004			
48	7,320	3.86	.19	.036			
49	3,870	3.59	-.08	.006			
1949-50	4,430	3.65	-.02	.000			
51	3,870	3.59	-.08	.006			
52	5,280	3.72	.05	.002			
53	7,710	3.89	.22	.048			
54	4,910	3.69	.02	.000			
1954-55	2,480	3.39	-.28	.078			
56	9,180	3.96	.29	.084			
57	6,140	3.79	.12	.014			
58	6,880	3.84	.17	.029			
(6)	N	30					
(7)	$\Sigma X$	109.97	-.13	2.665			
(8)	$\bar{X}$	3.666					
(9)	$\Sigma X^2$	405.7813	$S^2 = 2.6679/29 = .091996$				
(10)	$(\Sigma X)^2/N$	403.1134					
(11)	$\Sigma x^2$	2.6679	$S = .303$				
$P_\infty$ (12)	(13) 0.1	(14) 1.0	(15) 10	(16) 50	(17) 90	(18) 99	(19) 99.9
k (Ex 2)	3.09	2.33	1.28	0.0	-1.28	-2.33	-3.09
log $Q@P_\infty$ (Eq 4-5)	4.602	4.372	4.054	3.666	3.278	2.960	2.730
$Q@P_\infty$	40,000	23,550	11,320	4,630	1,900	912	537
$P_N$ (Ex 3)	.25	1.47	10.8	50	89.2	98.53	99.75

Note: Columns 4 and 5 are not required when desk calculator is available, but are shown to illustrate procedure usable without desk calculator. The difference between 2.665 and 2.668 is due to rounding values in column 4.

QUESTIONS  
CHAPTER 18  
DETERMINATION OF FLOOD FLOW FREQUENCY CURVES

1. When should frequency data be plotted? Why?
2. What is the basic objective of developing a frequency curve analytically?
3. What is the purpose of transforming frequency data to logarithms?
4. What does log-Pearson Type III mean?
5. What are the three basic statistics which define the frequency curve?  
How will changes in each of these statistics change the shape?
6. What might cause a change in each of these statistics?

DISCUSSION OF QUESTIONS  
CHAPTER 18  
DETERMINATION OF FLOOD FLOW FREQUENCY CURVES

1. The data should always be plotted when developing a frequency curve. The primary reason is for a visual comparison with the curve developed analytically.
2. The basic objective is to use a known frequency distribution that is representative of the data.
3. The logarithmic data often more closely fits a normal distribution.
4. Log, refers to the logarithmic transformation of the data. Pearson Type III refers to a known frequency distribution which has the characteristic that with zero skew it equals a normal distribution.
5. Mean, standard deviation, skew. A change in the mean value will raise or lower the magnitude of the event of a specific frequency. A change in the standard deviation will change the slope of the frequency curve. A change in the skew will alter the curvature of the frequency curve.
6. The mean can be increased or decreased by simply adding an additional value to the data set. The standard deviation will change when additional data are added to the data set particularly data with high or low values. The skew may change with the addition of values to the data set.

CHAPTER 19  
FREQUENCIES OF OTHER HYDROLOGIC PHENOMENA

Introduction

In this chapter frequency relationships of hydrologic phenomena other than annual peaks are discussed. This includes partial-duration flood frequencies, flood volume-duration curves, rainfall frequency distributions, low flow frequencies and flow-duration curves. Each of these relationships have a particular role in planning which cannot be fulfilled by the annual peak relationship which has been focused upon up until now. While much of what has been discussed applies to these other phenomena there are some important differences and these will be pointed out.

Partial-Duration Frequency Curve

A partial-duration frequency curve is one which uses all events above a selected base value. In the case of annual peaks, a partial-duration relationship includes all events which have occurred each year, which are equal to or above a selected base magnitude. The base is commonly selected equal to the lowest annual flood so that at least one flood in each year is included. For long records, however, the base may be raised so that on the average only 3 or 4 floods a year are included. It is important that the floods selected be independent events and be separated by substantial recession in stage and discharge. Partial duration curves are commonly used where it is desired to consider the second, third, etc. largest events each year, e.g., in agricultural flood damage computations when new crops are planted each season.

There is an important distinction in meaning between the exceedance frequency of the partial-duration distribution and annual distribution. In the partial-duration, there are more events than years (usually) so one speaks of exceedance frequency in events per year. For example, a certain magnitude is exceeded twice per year on the average. In an annual series, the number of events equals the number of years and thus exceedance frequency values higher than one per year are not possible. The partial series may be determined graphically or analytically. The additional floods, because they

are of lower magnitude, generally help to define the lower portion of the frequency curve and have little influence on the upper portion.

### Flood Volume-Duration Frequency Curves

These curves are used primarily in reservoir design and operation studies for estimating flood control space and for balancing flood hydrographs. Using the volume-duration curve for a selected frequency, the reservoir space needed to control the volume can be estimated (see Chapter 5 of HEC [4]). Also, in reservoir system studies it is desired to use hydrographs which are balanced, that is, hydrographs whose ordinates have been adjusted so that their volumes are equal to volumes from a volume-duration relationship at the selected frequency.

A frequency curve which represents the maximum 1-day average flow is commonly referred to as flood volume-duration curve and is developed by identifying the maximum 1-day flow which occurs each year and using these data to develop the frequency curve. The maximum 1-day flow is the average flow during this duration. The 1-day flow together with flows for other durations constitute a series of flood volume-duration curves. It is common practice to develop a series of curves rather than just a single curve for one volume for two reasons. First, a series is often needed and secondly, a series can be coordinated and developed as a family of curves thus improving the shape of each individual curve.

The procedures used for both plotting frequency data and developing the curves analytically are similar to those used for annual peak flows. Similarly, partial-duration series can be developed using all volumes of a specified duration over a particular base for each year. Page 5-11 of HEC [4] shows an example for a flood volume-duration series. The curve is interpreted in the same manner as the annual peak curve, e.g., a 1-day volume of 12,700 cfs will be exceeded on the average of once in 100 years.

### Rainfall Frequency Curves

The methodology presented for development of volume-duration flood flow frequency curves is generally applicable for developing rainfall

frequencies. The distribution commonly assumed is the log-normal, i.e., a normal distribution with the magnitudes of precipitation transformed to logarithms. Rainfall frequencies are not usually developed specifically for Corps planning studies, but rather are taken from Technical Paper 40 of the U.S. Weather Bureau and used for developing flood flow frequencies in basins with sparse data.

### Low Flow Frequency Curves

Low flow frequency curves are used when planning a reliable water supply. They can be used to determine storage requirements, to select sites for water supplies, and to appraise the adequacy of natural flows for allocation of water rights and waste disposal. Basically they show how frequently "on the average" a stream may fail to provide various flow rates under natural or regulated conditions. Figure 19.1 illustrates low flow curves for a 360 square mile drainage area (from Kansas Water Resources Board [6]).

Information on low flow frequencies is obtained from observed annual low flow events of durations of one day to 12 months. The shorter durations, say 1 to 30 days are needed by intermittent users and by those who must depend upon river or minor storage locations. Frequency information for durations of 60 to 180 days are useful for water users concerned with seasonal carryover. Longer duration information, say 12 months, are often used for estimating water supply availability for reservoirs. In developing flow frequency curves, the climatic year is selected instead of the water year or calendar year. The climatic year should start at a time of year when the flow is most likely to be high so that yearly low flow periods are likely to be independent. The data for each duration are developed from each climatic year by determining the lowest flow for that duration. After this is done for each year, the frequency curve is developed graphically or analytically in a manner similar to that for flood frequency events.

Experience has shown that it is more difficult to find a known frequency distribution to fit low flow data than peak flow data, thus analytical techniques such as log-Pearson Type III are not always applicable and



AVERAGE NATURAL DISCHARGE IN SECOND-FOOT PER SQUARE MILE

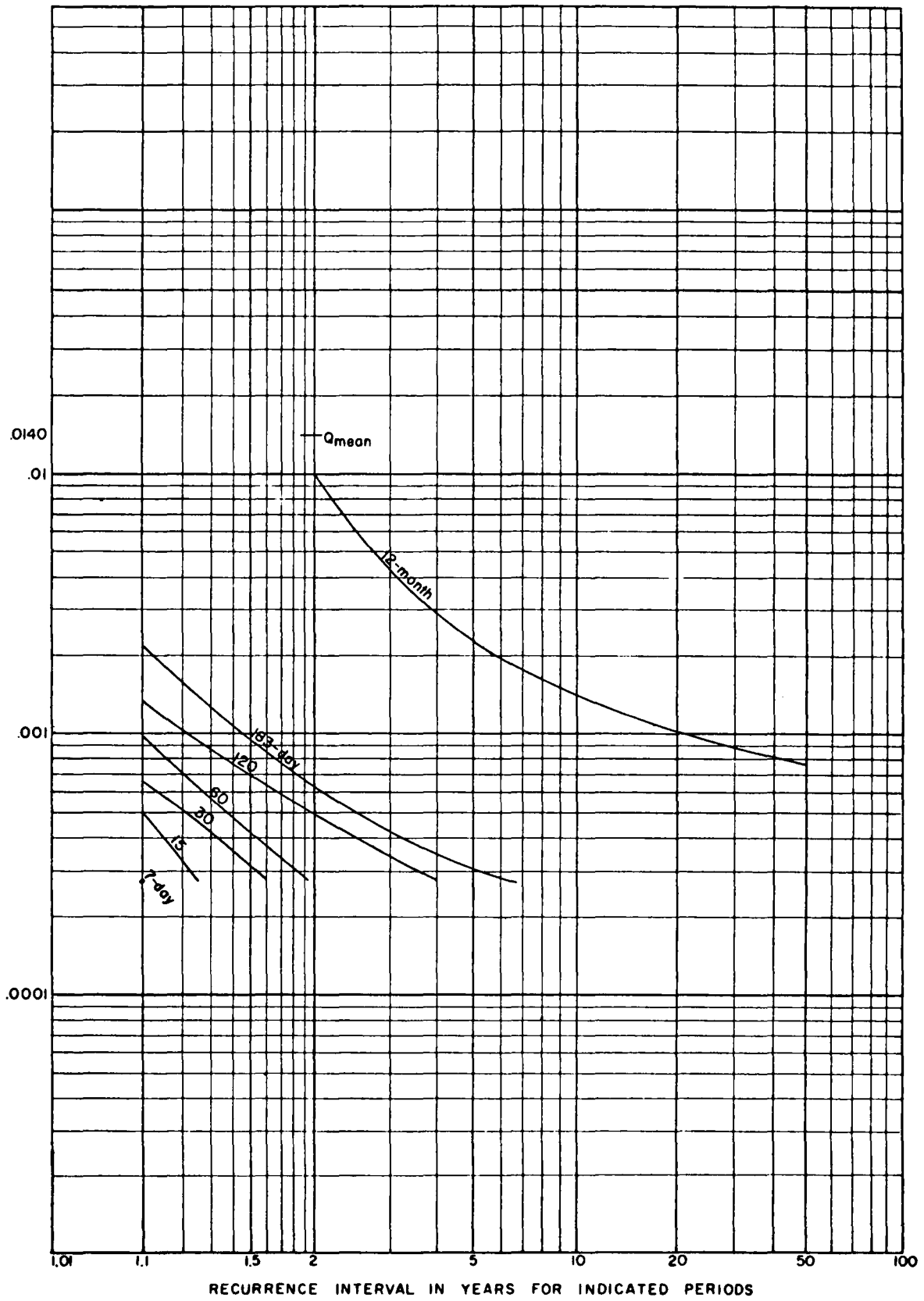


Figure 19.1 LOW FLOW FREQUENCY CURVES

graphical procedures are often used. One difficulty encountered with low flow data is the considerable effect of basin development on low flows. Such developments as diversions, groundwater pumpage and stream discharges can have a marked effect on the frequency distribution. Essentially the problem is that the sample data is often not representative of the parent population.

### Flow-Duration Curves

Flow-duration curves are also developed for planning dependable water supplies. They show the percentage time various rates of discharge have been equaled or exceeded. They are applicable for determining the probability of occurrence of various future flow rates, and generally for various problems associated with water supply, hydroelectric power, sediment production, and waste disposal. Figure 19.2 shows an example from Kansas Water Resources Board [7] of a flow-duration curve for the same drainage area as represented in Figure 19.1.

Flow-duration curves are developed by arraying all data of a selected duration, at a particular location, by order of magnitude, computing the percent of time the various rates are equaled or exceeded, then plotting the discharge rates against the corresponding percentages of time. Duration curves are commonly developed for daily durations, although weekly, monthly and even yearly durations have been used. Duration curves of yearly discharge have considerable value in appraising the yearly variation in flow.

The difference between flow-duration curves and low flow frequency curves lies in the data used to develop the curve and the interpretation of the curve. Flow-duration data includes all data of the selected duration, say daily flow, over the period-of-record. Low flow frequencies use only the lowest value each year, say lowest daily flow each year. Thus the exceedance probability is the probability that the daily value will be equaled or exceeded, on the average, each year. The flow-duration curve represents the percent of time a given value will be equaled or exceeded, and thus is not based on annual events, but includes all occurrences over any time period. In terms of usage, low flow frequency curves are being used more often today than flow-duration curves.

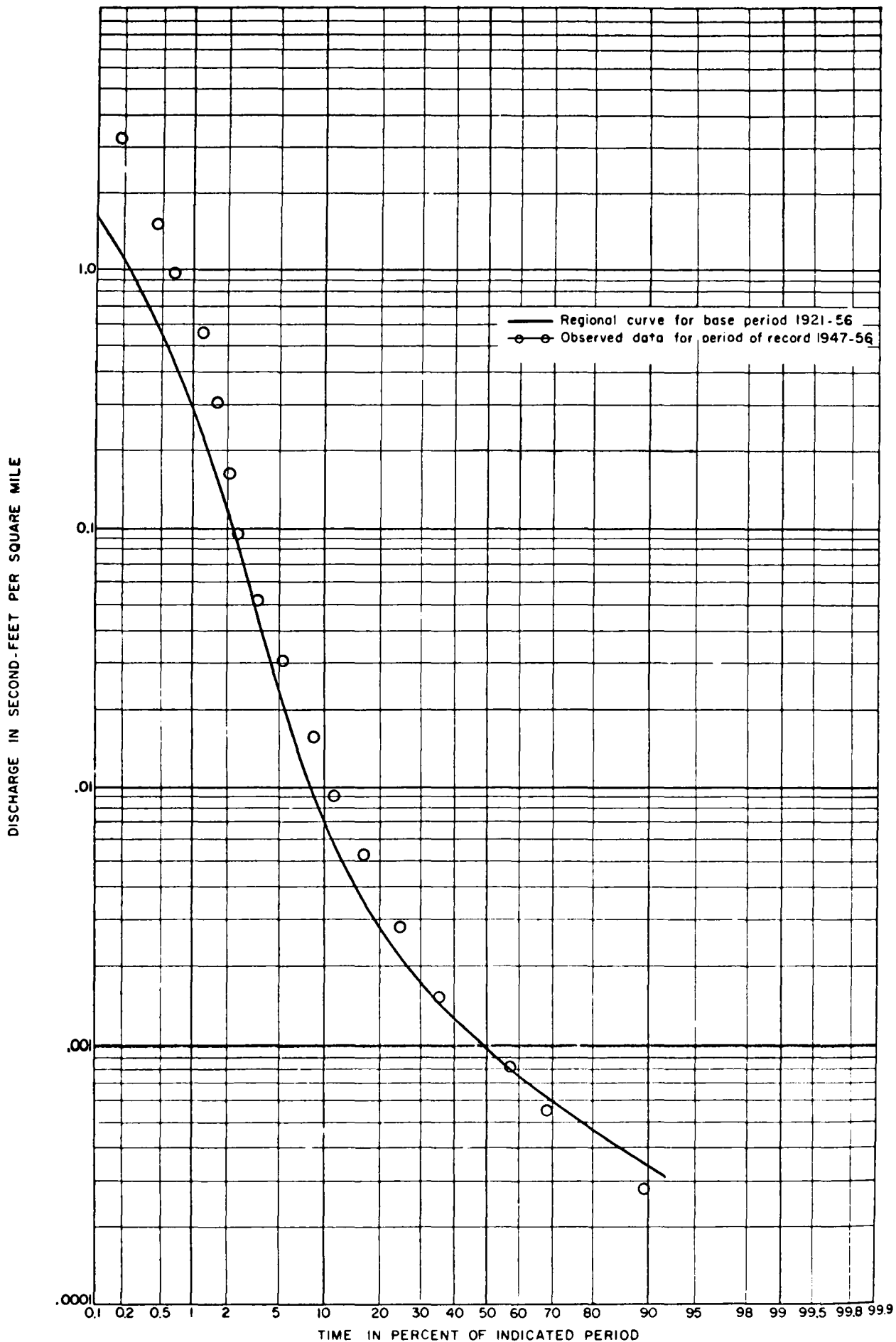


Figure 19.2 FLOW DURATION CURVE

## EXAMPLE

### PARTIAL-DURATION FREQUENCY DISTRIBUTIONS

An example of the graphical development of a partial-duration curve is shown on the following pages (See HEC [4], pages 4-03 to 4-07). All annual maximum flows and other peak floods above 3,000 cfs and separated by 10 days or more for the length of record are tabulated in columns 3 and 6 of Figure 19.3. These values are then tabulated in decreasing order of magnitude in columns 10 and 12. Note that there are no values tabulated under 3,000 cfs. Plotting positions up to 50 percent are assigned using Exhibit 1, Sheets 1 and 2, where the number of events  $N = 30$  (1928-1958), and  $m =$  order number of each event. These plotting values will correspond to those developed for the annual maximum peak distribution. Plotting positions larger than 50 percent are assigned using the equation  $P = (2m-1)/2N$  (page 4-02 of HEC [4]). Using the tabulated plotting positions, the partial-duration frequency curve is plotted in Figure 19.4.

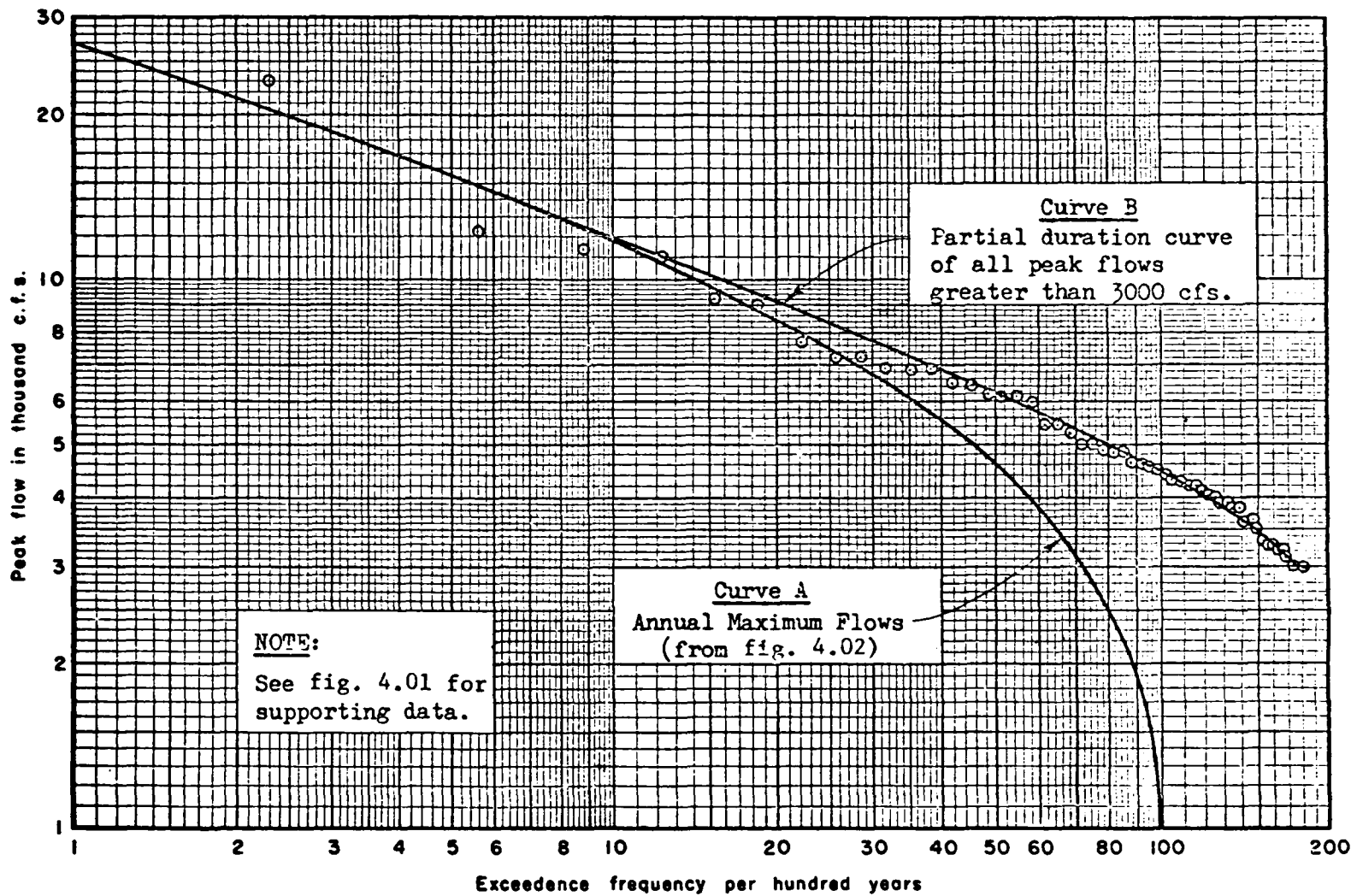
ILLUSTRATIVE EXAMPLE

TABULATION OF PEAK FLOW FREQUENCY DATA  
MILL CREEK NEAR LOS MOLINOS, CALIFORNIA

Events in order recorded						Events in decreasing order of magnitude					
Annual maximum, and all other flows above 3000 c.f.s. and separated by 10 days or more from larger flows						Annual Maximum		Partial-duration series (flows above 3000 c.f.s.)			
Water Year (1)	Date (2)	Flow (cfs) (3)	Water Year (4)	Date (5)	Flow (cfs) (6)	Plotting Position (7)	Flow (cfs) (8)	Plotting Position (9)	Flow (cfs) (10)	Plotting Position (11)	Flow (cfs) (12)
1928-29	3 Feb	1,520	1943-44	4 Mar	3,220	2.3	23,000	2.3	23,000	91.7	4,650
1929-30	15 Dec	6,000	1944-45	5 Feb	3,230	5.6	12,200	5.6	12,200	95.0	4,600
1930-31	23 Jan	1,500	1945-46	4 Dec	3,660	8.9	11,400	8.9	11,400	98.3	4,540
1931-32	24 Dec	5,440	1945-46	21 Dec	6,180	12.2	11,000	12.2	11,000	101.7	4,430
1932-33	16 Mar	1,080	1946-47	12 Feb	4,070	15.4	9,180	15.4	9,360	105.0	4,380
1933-34	29 Dec	2,630	1947-48	23 Mar	7,320	18.7	7,710	18.7	9,180	108.3	4,330
1934-35	4 Jan	4,010	1947-48	28 Apr	3,380	22.0	7,320	22.0	7,710	111.7	4,250
1934-35	28 Feb	3,190	1948-49	11 Mar	3,870	25.3	6,970	25.3	7,320	115.0	4,240
1934-35	8 Apr	3,040	1949-50	4 Feb	4,430	28.6	6,880	28.6	7,260	118.3	4,130
1935-36	11 Jan	3,930	1950-51	16 Nov	3,870	31.9	6,180	31.9	6,970	121.7	4,070
1935-36	21 Feb	4,380	1950-51	22 Jan	3,510	35.2	6,140	35.2	6,910	125.0	4,010
1936-37	14 Feb	3,310	1950-51	11 Feb	3,660	38.5	6,000	38.5	6,880	128.3	3,970
1937-38	20 Nov	4,700	1951-52	1 Dec	4,930	41.8	5,440	41.8	6,480	131.7	3,930
1937-38	11 Dec	23,000	1951-52	26 Dec	5,280	45.1	5,280	45.1	6,450	135.0	3,870
1937-38	2 Feb	5,050	1951-52	1 Feb	4,650	48.4	4,910	48.4	6,240	138.3	3,870
1937-38	23 Mar	4,950	1952-53	9 Jan	7,710	51.6	4,430	51.7	6,180	141.7	3,660
1938-39	8 Mar	1,260	1952-53	27 Apr	3,070	54.9	4,380	55.0	6,140	145.0	3,660
1939-40	2 Jan	4,600	1953-54	17 Jan	4,910	58.2	4,070	58.3	6,000	148.3	3,510
1939-40	28 Feb	11,400	1953-54	13 Feb	3,300	61.5	4,010	61.7	5,450	151.7	3,380
1939-40	30 Mar	9,360	1953-54	4 Apr	4,240	64.8	3,870	65.0	5,440	155.0	3,310
1940-41	24 Dec	6,240	1954-55	11 Nov	2,480	68.1	3,870	68.3	5,280	158.3	3,300
1940-41	10 Feb	12,200	1955-56	22 Dec	9,180	71.4	3,310	71.7	5,050	161.7	3,230
1940-41	1 Mar	4,250	1955-56	7 Jan	5,020	74.7	3,230	75.0	5,020	165.0	3,220
1940-41	4 Apr	7,260	1955-56	22 Feb	6,480	78.0	3,220	78.3	4,950	168.3	3,190
1941-42	3 Dec	4,130	1956-57	24 Feb	6,140	81.3	2,630	81.7	4,930	171.7	3,070
1941-42	16 Dec	6,910	1957-58	26 Jan	3,060	84.6	2,480	85.0	4,910	175.0	3,060
1941-42	27 Jan	5,450	1957-58	12 Feb	4,330	87.8	1,520	88.3	4,700	178.3	3,040
1941-42	6 Feb	11,000	1957-58	24 Feb	6,880	91.1	1,500				
1942-43	21 Jan	6,450	1957-58	21 Mar	4,540	94.4	1,260				
1942-43	8 Mar	6,970	1957-58	2 Apr	3,970	97.7	1,080				

19.8

Figure 19.3



NOTE:  
See fig. 4.01 for supporting data.

Curve A  
Annual Maximum Flows  
(from fig. 4.02)

Curve B  
Partial duration curve  
of all peak flows  
greater than 3000 cfs.

ILLUSTRATIVE EXAMPLE  
PARTIAL-DURATION FREQUENCY CURVE

EXAMPLE  
FLOOD VOLUME-DURATION FREQUENCIES

An example of the development and application of a flood volume-duration series of frequency curves is discussed on pages 5-01 through 5-16 of HEC [4]. The development of the curves both graphically and analytically is similar to that for annual peak flows; the main difference being that instead of using annual peak values, volumes are used. The procedure is as follows:

- o Determine the maximum values for each year for the desired series of the peak, 1-day, 3-day, etc., durations (Figure 19.5).
- o Array these values by decreasing order of magnitude and assign plotting positions.
- o Develop the curves analytically by computing the statistics of the frequency data.
- o Plot the curves developed analytically (Figure 19.6).
- o Make any necessary adjustments to the curves because of plotted data or coordination with the series.

Once the curves are developed and adjusted they are useful in reservoir sizing. This is illustrated on pages 5-12 and 5-14 through 5-16. Figure 19.7 (upper graph) was developed by going to Figure 19.6 with a given exceedance frequency and picking off the magnitude of flow for each duration and converting it to 1,000 acre-feet.

For example,

Exceedance frequency = 1 in 100 years

Duration	1-day	3-day	10-day	30-day
Flow (cfs)	12,700	8,200	3,800	2,050
Volume (1,000 ac-ft)	25.1	48.7	75.2	121.8

These data are plotted and the procedure repeated for other frequencies, 50-year, 20-year, 10-year, 5-year.

The lower graph (Figure 19.7) is a replot of the upper graph using arithmetic grids. A straight line on this lower graph represents a uniform flow rate (volume/time).

$$1 \text{ cfs} - \text{day} = 1.98 \text{ acre-feet}$$

Thus, if the maximum reservoir release were made equal to the maximum channel capacity below a reservoir this release, in cfs, could be plotted on the volume-duration curve. The intercept at the y axis is an estimate of the reservoir storage required to control the 100-year runoff with maximum release. For example, in Figure 19.7, 36,000 acre-feet of the storage space is needed to control the expected maximum 100-year runoff volume with releases of 2,000 cfs. The duration which is critical is 4 to 7 days. To express it another way, a reservoir of 36,000 acre-feet flood control space is needed to control (maximum 2,000 cfs release) the 4 to 7 day runoff volume which is expected to be exceeded once in 100 years.



**MAXIMUM-RUNOFF VOLUME FREQUENCY DATA--CHRONOLOGICAL ORDER**

Average Flows in c.f.s. at: Mill Creek nr. Los Molinos, California

Drainage area: 134 sq mi      Runoff type: All-season      Basin regulation: Natural

Water Year (1)	Peak		1-day		3-day		10-day		30-day		90-day		Water-yr. flow (14)
	date (2)	flow (3)	date (4)	flow (5)	first day (6)	flow (7)	first day (8)	flow (9)	first day (10)	flow (11)	first day (12)	flow (13)	
1928-29	3 Feb.	1520	3 Feb.	965	2 Feb.	719	1 Feb.	377	22 Apr.	292	9 Mar.	225	150
29-30	15 Dec.	6000	15 Dec.	4080	14 Dec.	2400	10 Dec.	1270	10 Dec.	590	10 Dec.	475	255
30-31	23 Jan.	1500	23 Jan.	1200	22 Jan.	650	11 Mar.	315	11 Mar.	235	27 Feb.	186	121
31-32	24 Dec.	5440	27 Dec.	2160	26 Dec.	1380	23 Dec.	1040	21 Dec.	480	18 Mar.	380	214
32-33	16 Mar.	1080	28 Mar.	662	28 Mar.	472	25 May.	386	20 May.	330	27 Mar.	280	150
33-34	29 Dec.	2630	29 Dec.	1730	29 Dec.	1300	29 Dec.	745	27 Mar.	335	7 Feb.	290	166
34-35	4 Jan.	4010	4 Jan.	2300	7 Apr.	1470	7 Apr.	958	3 Apr.	760	28 Feb.	565	290
35-36	21 Feb.	4380	21 Feb.	2660	21 Feb.	1920	14 Feb.	1220	12 Feb.	716	9 Jan.	513	270
36-37	14 Feb.	3310	4 Feb.	1540	4 Feb.	902	12 Mar.	584	1 May	520	11 Mar.	478	219
37-38	11 Dec.	23000	11 Dec.	12300	10 Dec.	7340	10 Dec.	2750	10 Dec.	1100	12 Mar.	890	566
38-39	8 Mar.	1260	3 Dec.	594	8 Mar.	453	19 Mar.	350	3 Mar.	329	7 Mar.	260	156
39-40	28 Feb.	11400	27 Feb.	7640	27 Feb.	6150	26 Feb.	2580	3 Feb.	1200	1 Jan.	915	383
40-41	10 Feb.	12200	11 Feb.	5980	10 Feb.	4730	9 Feb.	1990	8 Feb.	1310	8 Feb.	605	467
41-42	6 Feb.	11000	6 Feb.	5690	5 Feb.	3250	1 Feb.	1810	22 Jan.	1160	30 Nov.	825	443
42-43	8 Mar.	6970	23 Jan.	3770	21 Jan.	3060	21 Jan.	1660	21 Mar.	820	5 Mar.	654	373
43-44	4 Mar.	3220	4 Mar.	1720	3 Mar.	890	29 Feb.	515	29 Apr.	373	29 Feb.	330	198
44-45	5 Feb.	3230	5 Feb.	1580	1 Feb.	1260	1 Feb.	890	31 Jan.	540	1 Feb.	392	170
45-46	21 Dec.	6180	27 Dec.	3100	27 Dec.	2320	21 Dec.	1760	21 Dec.	890	30 Oct.	470	294
46-47	12 Feb.	4070	12 Feb.	2590	11 Feb.	1380	11 Feb.	630	11 Feb.	400	11 Feb.	350	192
47-48	23 Mar.	7320	23 Mar.	3650	23 Mar.	2040	23 Mar.	865	23 Mar.	770	23 Mar.	682	310
48-49	11 Mar.	3870	23 Mar.	1810	10 Mar.	1300	10 Mar.	700	2 Mar.	410	2 Mar.	407	195
49-50	4 Feb.	4430	4 Feb.	3210	4 Feb.	2360	4 Feb.	990	17 Jan.	590	18 Mar.	452	251
50-51	16 Nov.	3870	22 Jan.	2120	19 Nov.	1540	3 Dec.	1060	16 Nov.	840	1 Dec.	565	343
51-52	26 Dec.	5280	1 Dec.	3040	1 Feb.	2330	31 Jan.	1250	24 Jan.	860	14 Mar.	726	445
52-53	9 Jan.	7710	9 Jan.	5240	8 Jan.	3200	7 Jan.	1900	26 Dec.	1080	1 Dec.	570	348
53-54	17 Jan.	4910	5 Apr.	2290	4 Apr.	1870	3 Apr.	1000	9 Apr.	740	12 Feb.	633	318
54-55	11 Nov.	2480	15 Nov.	1060	14 Nov.	565	2 Dec.	480	2 May	402	25 Mar.	325	202
55-56	22 Dec.	9180	22 Dec.	6770	21 Dec.	5060	18 Dec.	3260	19 Dec.	1880	18 Dec.	1080	493
56-57	24 Feb.	6140	24 Feb.	3840	24 Feb.	2630	24 Feb.	1380	23 Feb.	806	23 Feb.	528	257
57-58	24 Feb.	6880	24 Feb.	3580	24 Feb.	2530	16 Feb.	1560	29 Jan.	1290	24 Jan.	918	480

Comp. by: R.P.L.

Date: May 1959

Sheet:

Station: USGS 11-3810

19.12

Figure 19.5

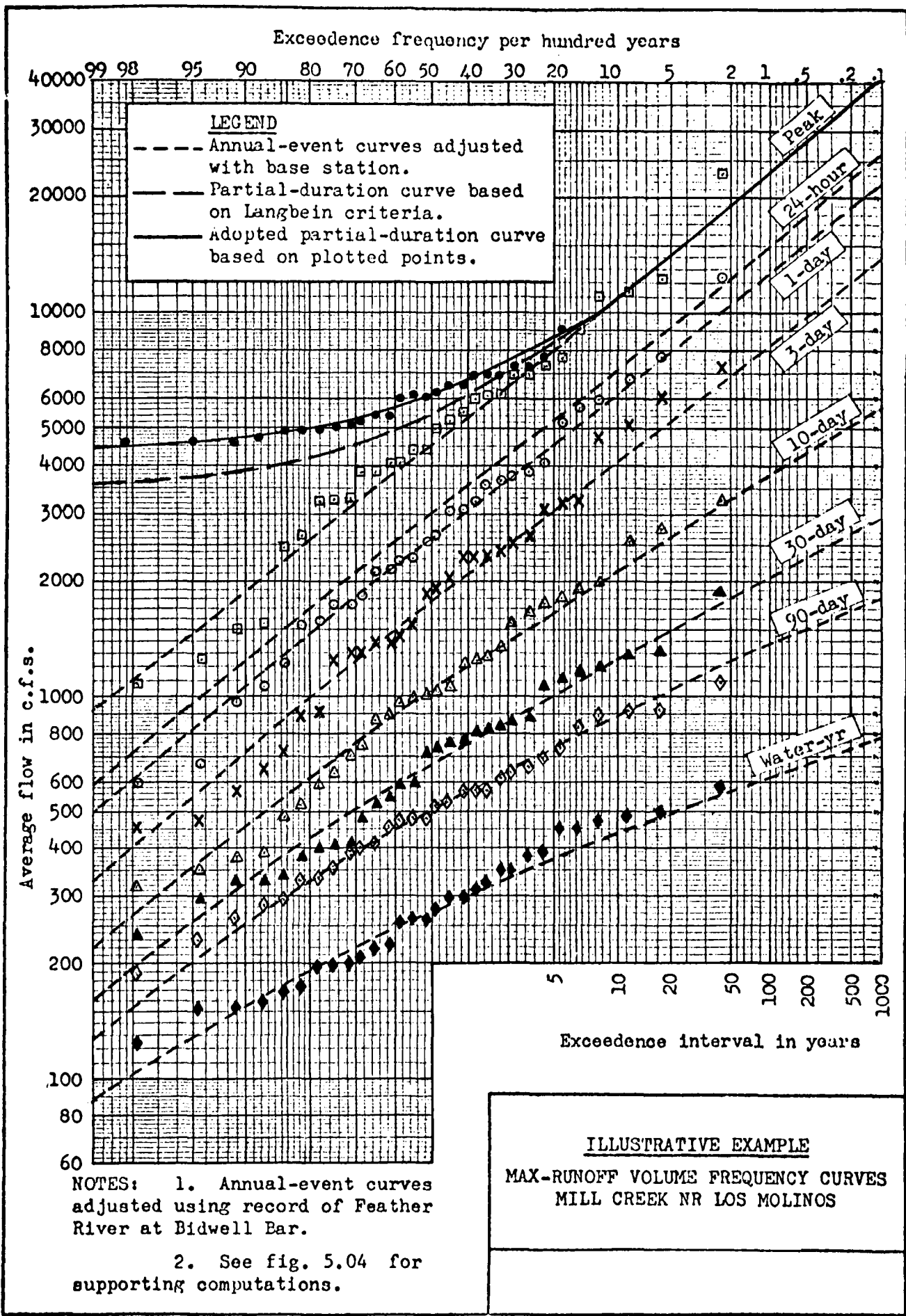
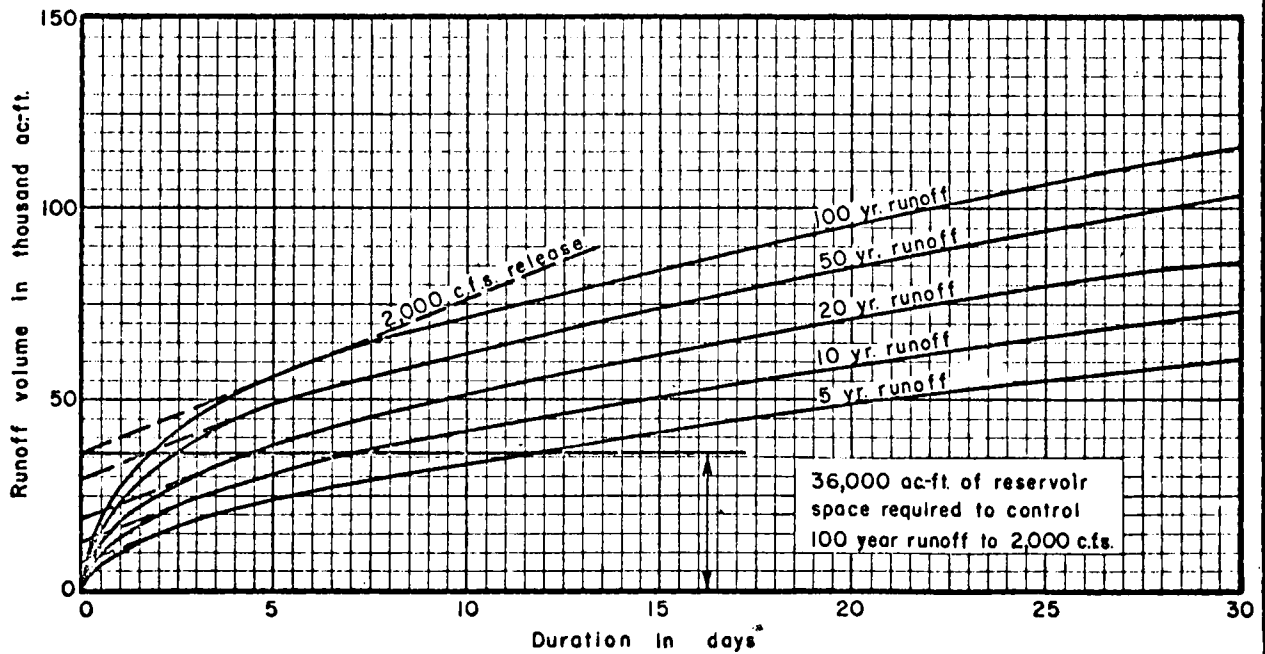
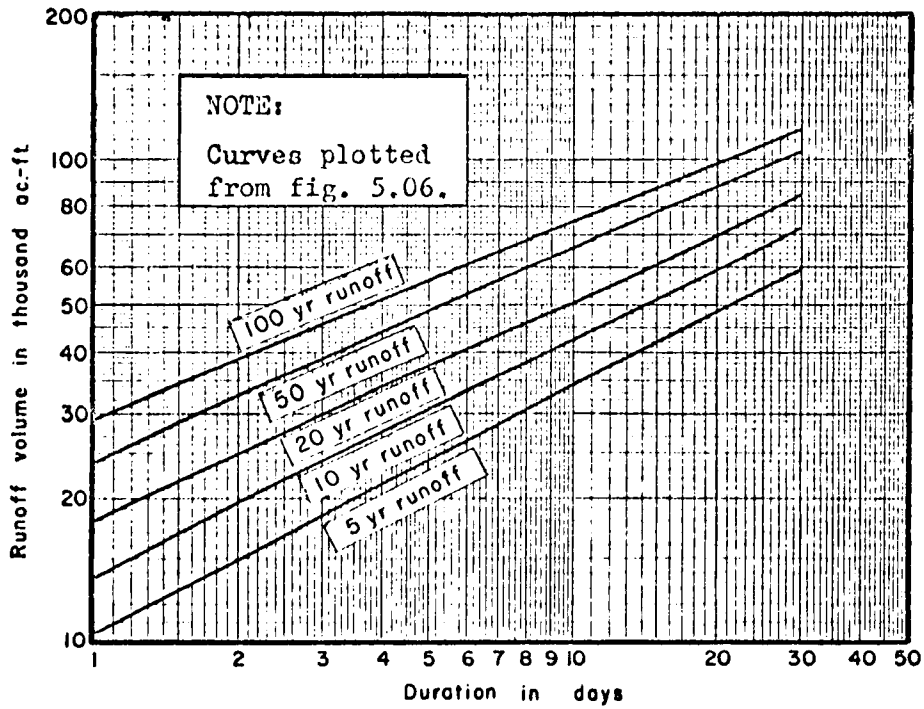


Figure 19.6



ILLUSTRATIVE EXAMPLE  
**VOLUME-DURATION CURVES**  
**MILL CR NEAR LOS MOLINOS, CALIFORNIA**

Figure 19.7

QUESTIONS  
CHAPTER 19  
FREQUENCIES OF OTHER HYDROLOGIC PHENOMENA

For each type frequency curve listed below, describe how it is developed and what it is used for in water resources planning.

- a. annual peak flow
- b. partial-duration
- c. flood volume-duration
- d. rainfall
- e. low flow
- f. flow-duration

DISCUSSION OF QUESTIONS  
CHAPTER 19  
FREQUENCIES OF OTHER HYDROLOGIC PHENOMENA

- a. A frequency curve for annual peak flows is developed using the maximum flow for each year of record. It is used in flood control planning where the maximum flow to be expected is of concern.
  
- b. Partial-duration frequency curves allow the hydrologist to determine the frequency of events at locations which are flooded more often than once a year. The curve is developed by using all flood flows above a selected base value. Partial duration curves are used in flood control planning.
  
- c. Flood volume-duration curves are, as the name implies, used in planning for flood control. Volumes are particularly useful in sizing reservoirs and other facilities. They are developed by selecting the maximum annual volume for a selected duration, e.g., 3-day, from each year of record.
  
- d. Rainfall frequencies are developed from rainfall data of various durations (5 min ... 24-hr) at a single station. These frequencies are often used in the Corps to develop runoff hydrographs in ungaged watersheds.
  
- e. Low flow frequency curves are developed by selecting the lowest annual flow for each year of record. They are used in low flow studies for water supply, waste disposal, etc.
  
- f. Flow duration curves are developed using all flow values and represent the percent of time specified flows are equalled or exceeded during a given period. Flow duration curves are used in low flow studies for hydroelectric power, etc.

CHAPTER 20  
RELIABILITY OF FREQUENCY CURVES

Statistical Reliability Criteria

The frequency curve developed using the methodology outlined in Chapter 18 is only an estimate of the curve which would exist if all the population data were known. It is not an exact representation, it was derived from a sample of the parent population. This sample changes as more events occur, and the estimate will normally be improved as more data becomes available. Today's frequency curve is simply today's best estimate of the frequency distribution of the parent population.

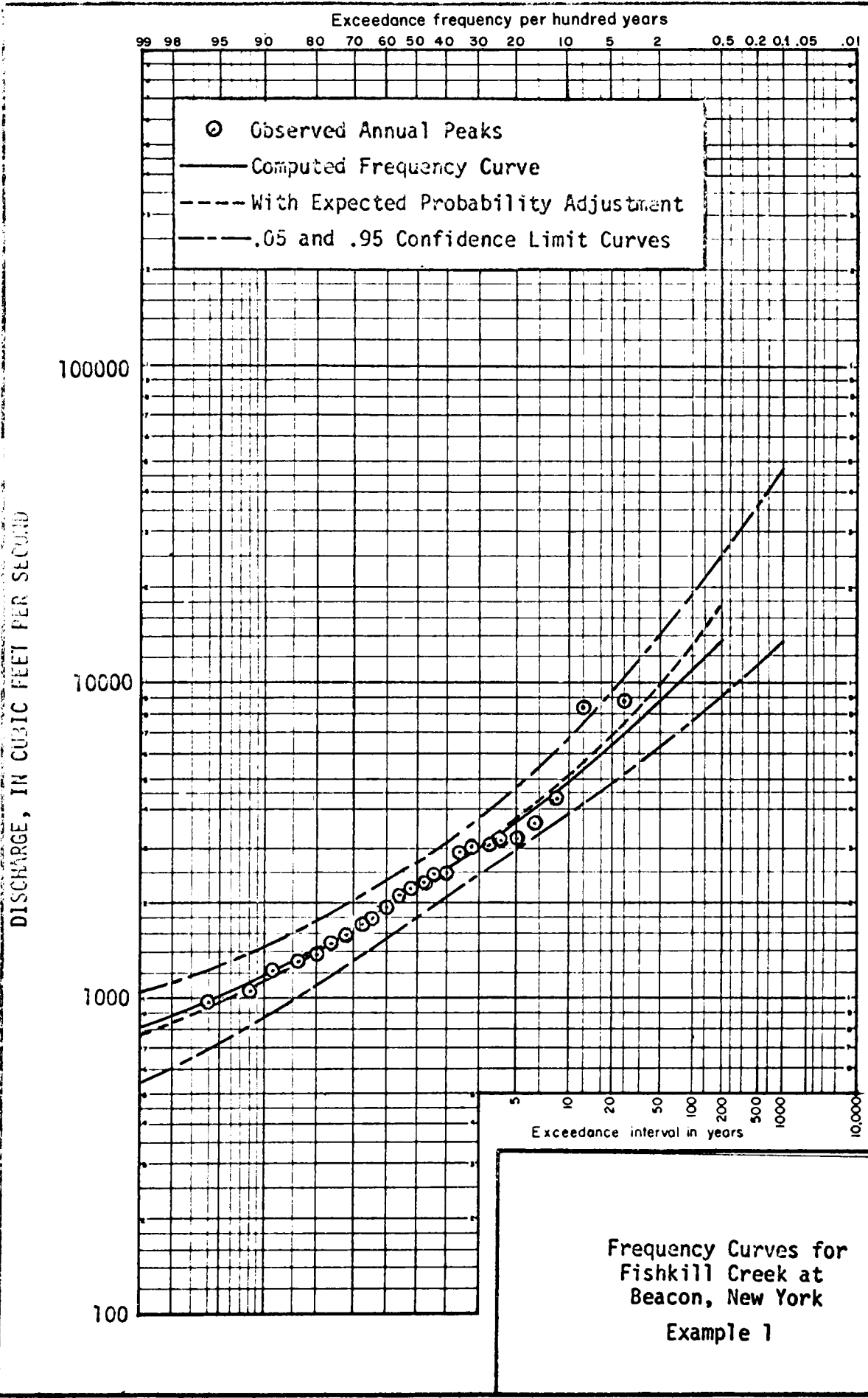
There are many factors which influence the sample data, and which in turn influence the reliability of the frequency estimate. Some of these were discussed in Chapter 17 in the context of gathering the sample. Several are discussed here in the context of reliability of the frequency estimate.

- o The representativeness of the sample of the parent population is a key factor in determining the reliability of the frequency curve. HEC [4] points out that two large floods added to the sample data can reduce the estimated frequency of a given event from once in 1,000 years to once in 200 years.
- o The variability of events within the sample data is also an important factor affecting reliability of frequency estimate, assuming of course that the observed sample is representative. HEC [4] gives an example of this condition.
- o A small sample has less chance of being representative of the parent population than a large one, thus frequency estimates based upon small samples will be less reliable.
- o It is always desirable to use the most reliable sources of data and guard against systematic errors, i.e., errors which influence all data values.

## Confidence Limits

Various statistical criteria have been developed with which to measure quantitatively the reliability of frequency estimates. This is one advantage of using analytical techniques for developing frequency curves. One commonly used criterion is confidence limits. Confidence limits can be used to measure the uncertainty of the estimated exceedance probability for a selected discharge or to measure the uncertainty of the discharge at a selected exceedance probability. WRC [3] illustrates the computational procedure. The variables are the level of uncertainty, the number of years (sample size), and the exceedance probability. Generally, for a selected level of uncertainty the confidence limits expand (that is we are less confident of our estimate) as the length of record decreases and the exceedance probability increases. Figure 20.1 shows an example of the confidence limit curve.

The confidence limit curve is a statistical measure of the confidence one can place in the frequency curve. Normally the 5 percent level of significance is used. The planner is usually not so interested in knowing the confidence limits per se, but rather what they mean in terms of using the frequency curve, and if the curve is not reliable, what the alternatives are. In answer to the first question, the planner needs to translate the confidence limits to more meaningful criterion. For example, in the design of a levee at the 5 percent level of significance in which the value of the 100 year flood is 20,000 cfs (upper confidence limit) and the frequency curve is 13,000 cfs, how sensitive is the levee height to these values? Is the difference .5 feet or 5 feet? Similarly, if the upper and lower limit at 5 percent level for the exceedance interval of the 100-year flood were 25 years and 350 years what difference would this make in the sizing of a project? Thus, through sensitivity analysis the planner learns the effect of frequency curve reliability upon the plan and may be able to made adjustments which will accommodate this uncertainty. Regarding the second question concerning highly unreliable frequency curves, after all has been done to make them the best possible, one must recognize that it is the best available today and using the confidence limits the planner can incorporate this uncertainty into the plan.



Frequency Curves for  
Fishkill Creek at  
Beacon, New York  
Example 1



## Extrapolation

Extrapolation of frequency curves beyond experienced values is highly dangerous. It is recommended, therefore, that some estimates be made of higher floods to guide the extrapolation. Several approaches are often taken. One is to use rainfall frequency information to estimate runoff magnitudes. A second is to use hypothetical floods, and a third is to use frequency data from other basins. These approaches are not intended to provide another point to plot, but rather to serve as a guide in extrapolating the frequency curve at hand.

QUESTIONS  
CHAPTER 20  
RELIABILITY OF FREQUENCY CURVES

1. What data characteristics make a frequency curve more reliable or less reliable?
2. Assuming confidence limits have been developed for a frequency curve, how can these limits be used by the planner to account for the uncertainty in his information?
3. Why is so much adjustment necessary in frequency curve development? Is it not simply a big guess?

DISCUSSION OF QUESTIONS  
CHAPTER 20  
RELIABILITY OF FREQUENCY CURVES

1. The variability of the data within the sample set; the sample size; the accuracy of the data; the representativeness of the data.
2. By making sensitivity analyses to determine how sensitive the plan (size, location, features, etc.) is to changes in the magnitude of flow or recurrence interval).
3. Because most streamflow records are such small samples of the parent population there is considerable uncertainty about what is the most representative frequency curve. Every attempt should be made to use all available information, experience and judgment to develop the curve. This is more than a big guess because the development of the curve is governed by rational rules and criteria whereas a guess is not.

## CHAPTER 21 REGIONAL ANALYSES

### Introduction

Regional analysis involves the collection and use of data from more than one gage. Such analyses are conducted in order to make use of information from other locations which have similar physiographic features. Experience has shown that this regional information is useful for extending gage records, estimating individual missing events, and estimating runoff from basin characteristics.

### Extending and Completing Individual Records

Streamflow record length often varies widely from gage to gage throughout a watershed. Using statistical techniques short records can often be extended by using a long record station if there is a reasonable correlation between the two. This extension is accomplished by adjusting the mean and standard deviation of the short record station and computing an extended length of record. In a similar manner, events can be estimated from concurrent records at nearby station to extend or complete data at another station. The frequency curve can then be developed using these adjusted data, which statistically speaking, is a better estimate of the frequency curve of the parent population.

Details of the computational procedures used to make these adjustments are described in HEC [8] and WRC [3].

### Regional Analysis of Flood Flows

It is often necessary in planning studies to develop frequency curves at locations where streamflow records do not exist. One approach to this problem is to develop regional maps of drainage basin characteristics from data at locations where data are known. Appropriate values of these characteristics can be read from the maps for the location in question and peak runoff values can be computed and frequency probabilities assigned. An example of this approach is the relationship:

$$Q_p = .001 C_p A^{.85} P^2 K$$

where  $Q_p$  = peak annual runoff  
 $C_p$  = peak runoff coefficient  
A = drainage area  
P = normal annual precipitation  
K = elevation factor

$C_p$  and K are determined from regional maps of these parameters, A and P are known and  $Q_p$  is computed. The probability assigned to this event is determined from regional values of the standard deviation.

The basin characteristics may also include such parameters as slope, surface storage, infiltration and stream length. An example of this type of regional analysis is shown on page 7-10 of HEC [4].

### Generalized Skew Coefficients

As discussed in Chapter 18, generalized skew coefficients are recommended for use in development of frequency curves since individual values are highly unreliable. Generalized values are developed for small geographic areas by computing skew coefficients for individual locations and weighting them according to record length to determine a regional value. For larger areas isopleths (contours) of equal skew values are plotted on a regional map at the centroid of the basin. Regional values are then selected from the map for any particular basin. A generalized skew map is shown in WRC [3], and procedures for developing such maps are presented.

QUESTIONS  
CHAPTER 21  
REGIONAL ANALYSES

1. Why perform regional analyses?
2. Why is it desirable to develop generalized skew coefficients?
3. The frequency curves shown on the next pages were developed using regression equations which related the mean, standard, deviation, and skew coefficient to drainage basin characteristics. These statistics were estimated for each station and the frequency curve plotted. Also, shown is the recorded streamflow data which was plotted using plotting positions and the maximum annual event for each year of record. What might cause the differences between the regionalized curve and plotted data in each case?

DISCUSSION OF QUESTIONS  
CHAPTER 21  
REGIONAL ANALYSES

1. To make use of data available at other locations in a region which have similar hydrologic and topographic characteristics.
2. It is highly unreliable if developed for a single location because of the structure of the statistic  $(X - \bar{X})^3$ . Extreme values result in a very large value of this statistic when raised to the third power.
3. a. Station 4778 (Figure 21.1)

The watershed above this station has been extensively urbanized, more so than many other watersheds included in the development of the regionalized statistics. As a result, one would expect the graphical plot of historic data to be higher (greater flows for the same frequency).

- b. Station 4480 (Figure 21.2)

This is an example of a good fit of a regionalized curve to historic data.

- c. Station 4455 (Figure 21.3)

This watershed has considerable marsh land and a relatively low basin slope (8 ft/mi); both characteristics are conducive to storing water. Hence, one might expect the station data to yield a frequency curve lower than one developed regionally where less storage capability exists.

- d. Station 4320 (Figure 21.4)

Flow at station 4320 is regulated upstream by a hydropower project. This regulation is not reflected in the regionalized curve.

e. Station 4205 (Figure 21.5)

The very low value reflects a coding error which detracts from an otherwise very good fit. Moral: check data carefully.

f. Station 3330 (Figure 21.6)

This plot shows a positive skew for the regional curve and negative skew for the historic plot. Except for this, the fit is good. It may be that the skewness of the short record is not indicative of a long record. Also, there is a possibility that the first point is a low outlier.

g. Station 2030 (Figure 21.7)

A high outlier is indicated. Its magnitude should check with data from other stations and a physical explanation sought. Did a dam break? Was the storm the largest of all known regional storms?



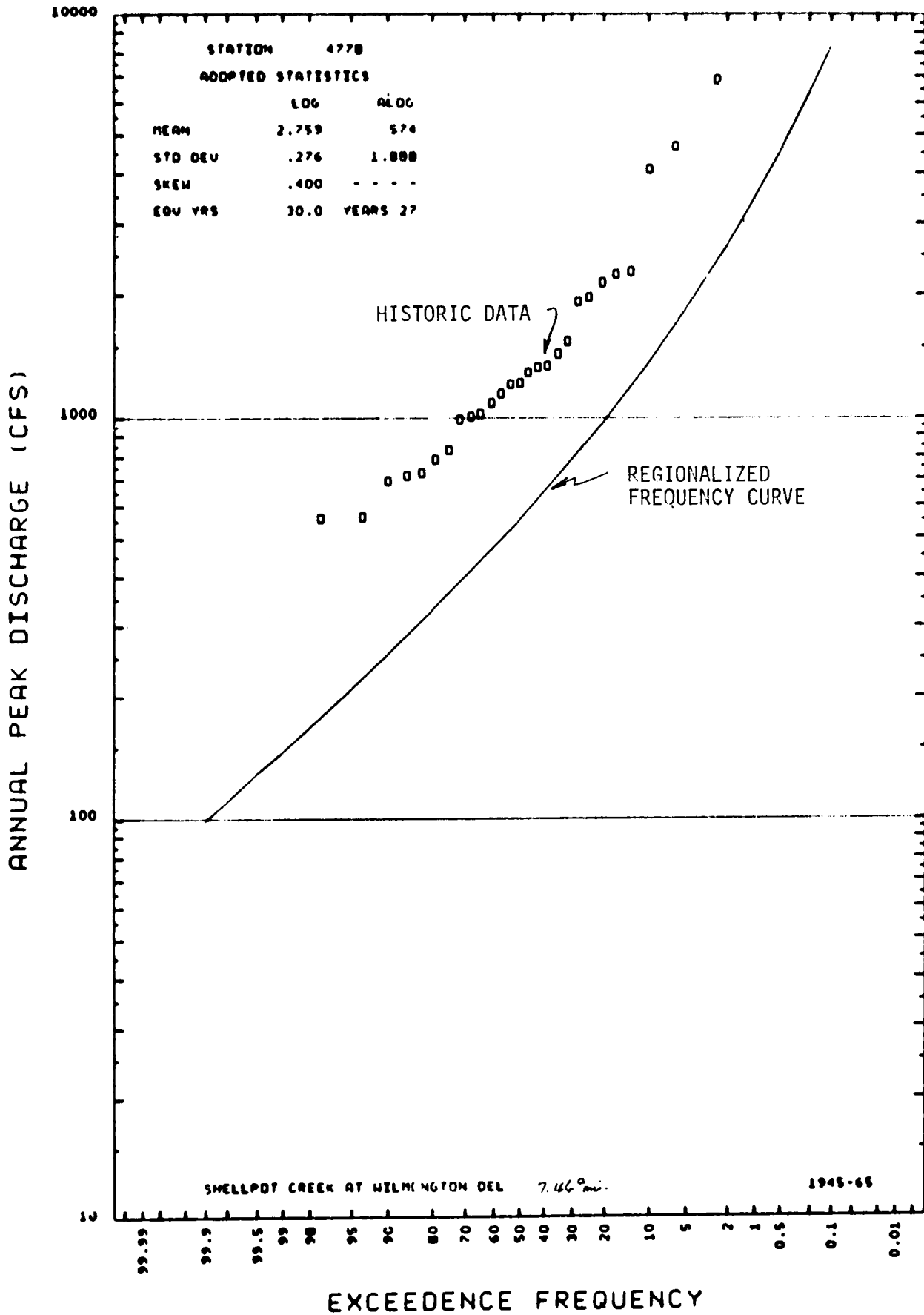


Figure 21.1

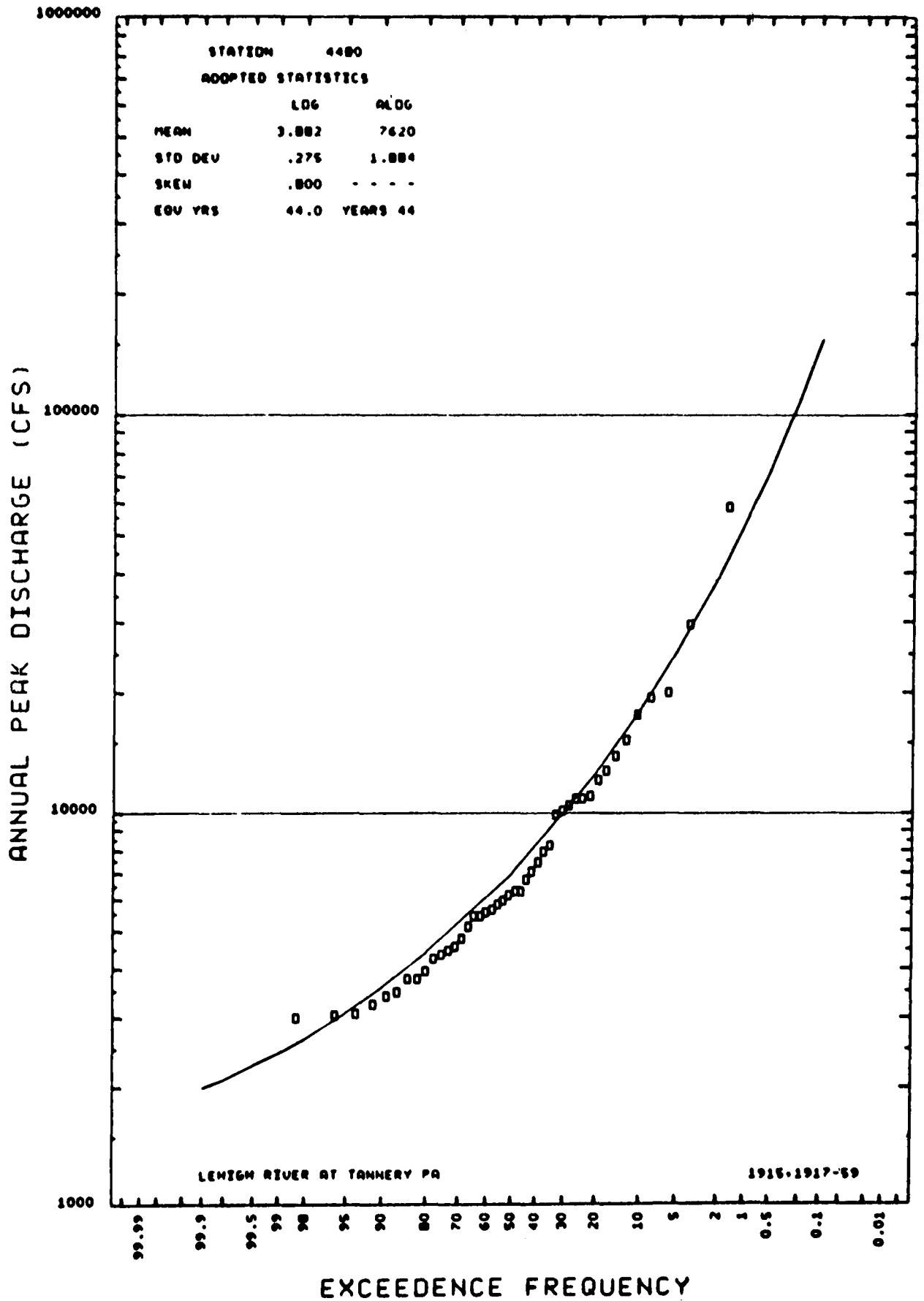


Figure 21.2

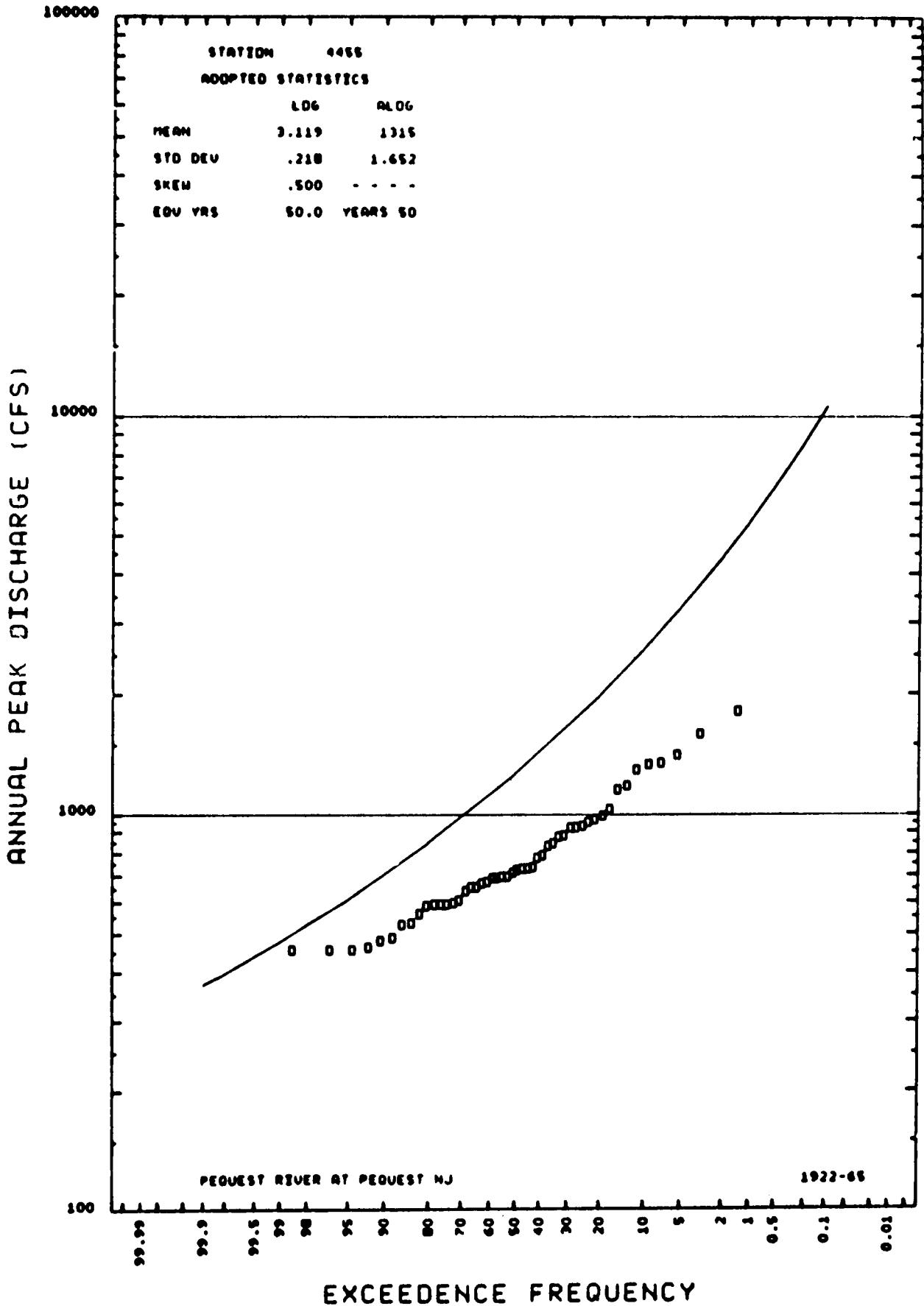


Figure 21.3

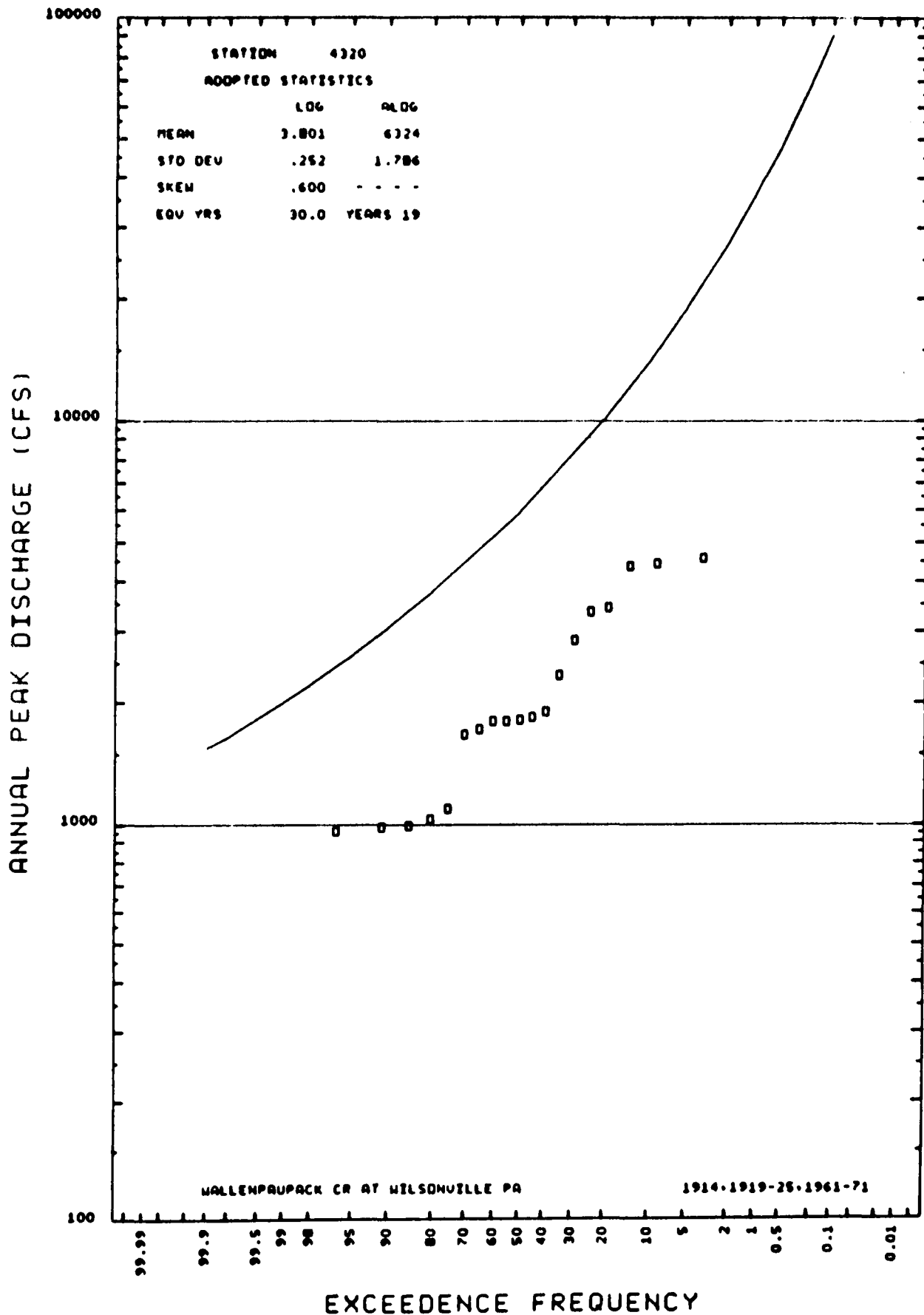


Figure 21.4

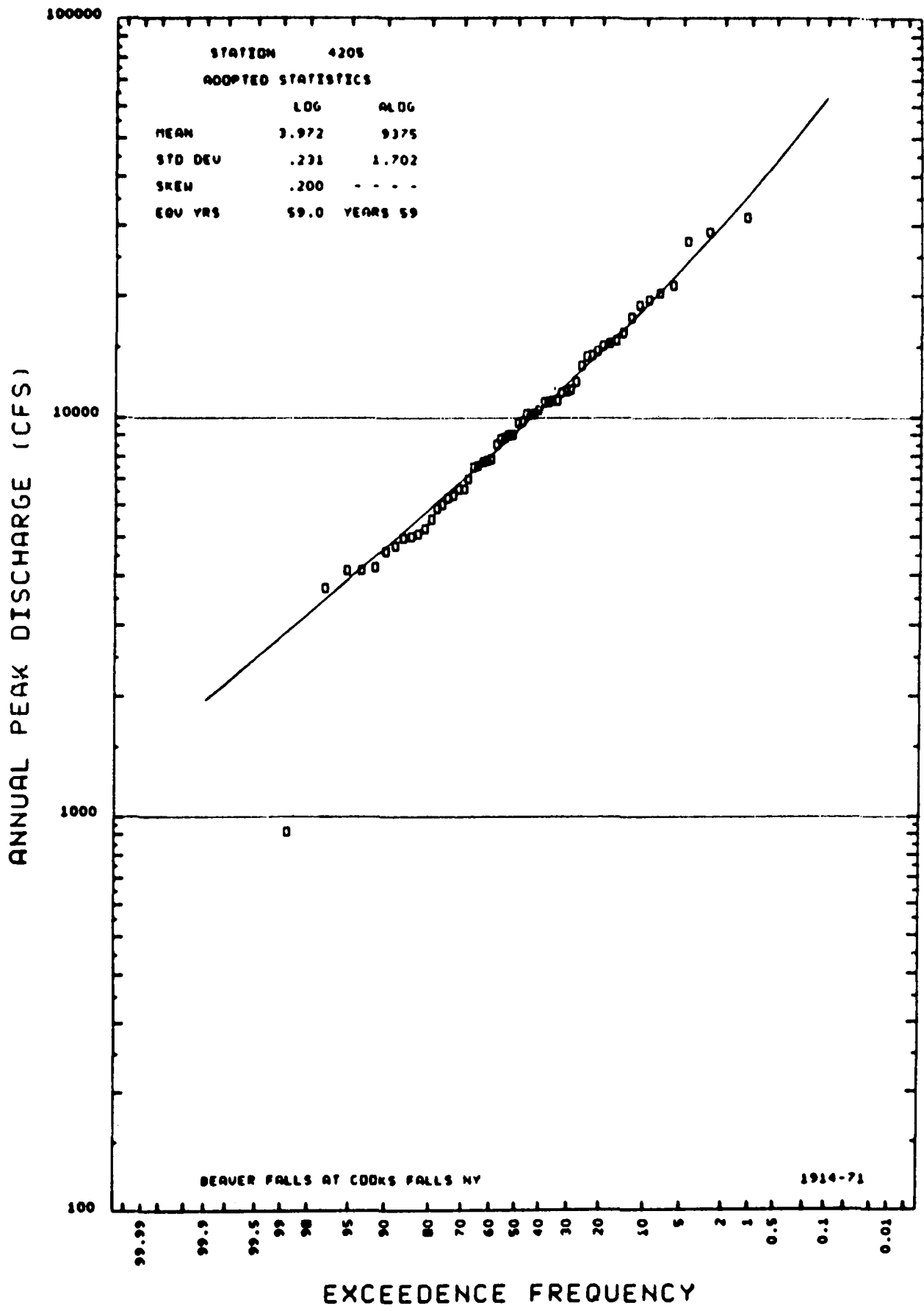


Figure 21.5

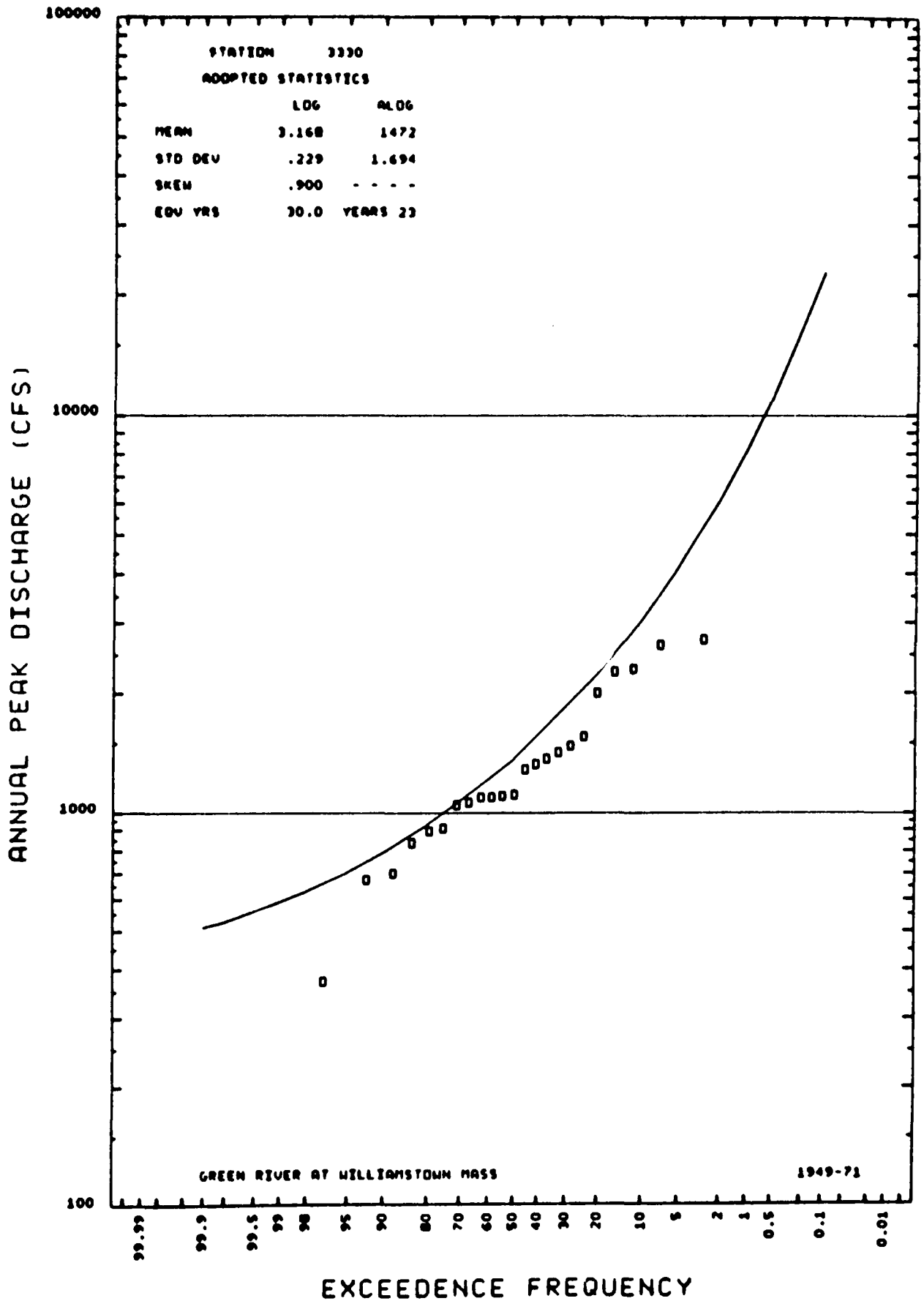


Figure 21.6

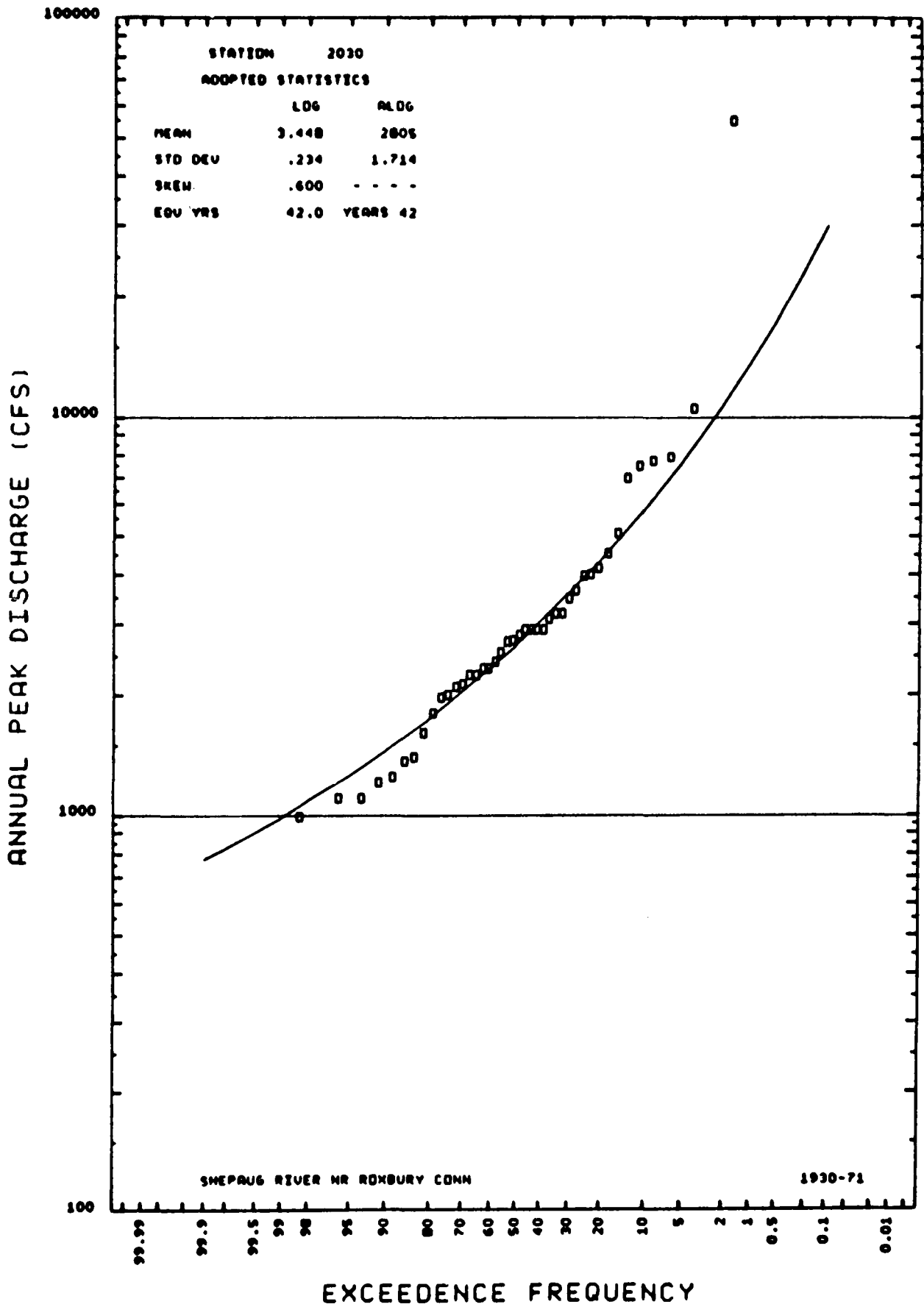


Figure 21.7

## CHAPTER 22

### DEVELOPMENT EFFECTS ON FREQUENCY CURVES

#### Introduction

Frequency curves as discussed in Chapters 17 through 21 are developed using data from past events. The planner, working in the present, is concerned with future conditions: what the hydrologic, economic and environmental effects will be of certain alternative plans and how future conditions might change even without these alternatives. The effects of the future on a frequency distribution of streamflow is not the only change the planner is concerned with, but is an important one because it reflects how the future is expected to influence the availability of the water resource itself. This Chapter will discuss the effects of development on the frequency distribution. Chapter 23 will deal with how these effects influence other hydrologic and economic information.

#### Types of Changes

Development changes which affect a frequency distribution are those which will permanently alter the streamflow magnitude at a specific location. There are generally three types: changes which modify the runoff; changes which store streamflow; and changes which divert streamflow.

Runoff: For most streams streamflow primarily originates in the watershed from rainfall. Some of this precipitation infiltrates into the ground, and some runs off. As it collects in rivulets, then streams, and finally rivers, it increases in magnitude. Alternations to the watershed surface can change the amount of water which runs off. For example, a change in land use from agricultural to residential will significantly decrease the infiltration rate because impervious surfaces such as rooftops, roads, and parking lots cause more water to run off than more permeable surfaces. These changes to the land surface result in greater magnitudes of streamflow, and because they may be considered permanent they alter the frequency distribution of streamflow events.

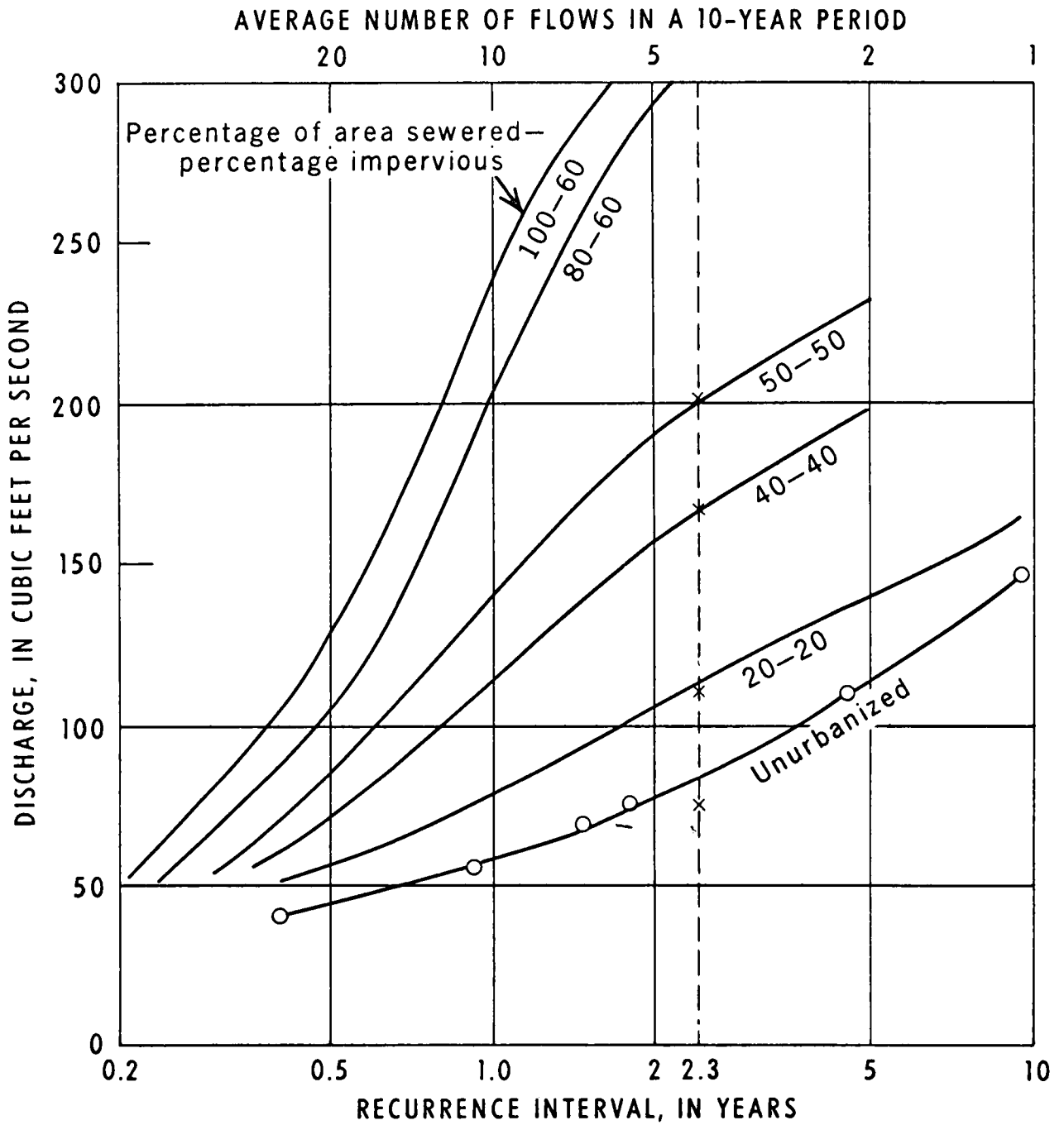


Runoff is also affected by development which result in changes to the conveyance system. Cleared channels convey water more rapidly than do those with vegetation; storm sewers convey water more rapidly than do natural channels. Thus, changes to the watershed often bring changes to the conveyance system which affect the travel time and ultimately the timing of the streamflow hydrographs at confluences. When hydrographs are combined, timing affects the magnitude of combined flow.

Figure 22.1 (taken from Leopold [8]) shows graphically the effects of watershed changes on a frequency distribution. Note that the range of the recurrence interval is from 0.2 to 10 years. This lower range is where watershed changes have the most effect on runoff. Figure 22.2 shows a frequency distribution over the full range of events. Note the lesser effect in the higher range. The reason for this is that surface imperviousness has less effect on runoff from floods of greater magnitudes because of their greater duration and intensity of rainfall.

The significance of any watershed will depend upon the size of the change relative to the size of the watershed. A new shopping center is not likely to significantly influence the runoff from a 60 sq. mi. area; nor is a storm drainage system for a residential subdivision. However, over time, there may be many new shopping centers and new subdivisions built and the resulting cumulative change may become significant.

Storage: Storage of water upstream can alter the frequency distribution of events at locations downstream. The storage may be brought about by ponding, construction of reservoirs, and availability of flood plain land. The magnitude of the change on the frequency distribution will depend upon the volume of runoff and the volume of storage available. Reservoirs are designed to alter the time distribution of streamflow; peak inflows are stored and subsequently released at a later time and lower rate. Thus, reservoirs reduce the streamflow downstream for rarer events and increase the streamflow for less rare events (caused by releases of water stored during high flow periods). Ponds or lakes can affect frequency distributions if the storage is large enough and the timing is right. Because there is often no release control associated with their operation, they could fill early and have no influence on the peak.



**Figure 22.1 EFFECT OF URBANIZATION ON FLOOD FREQUENCY CURVES**

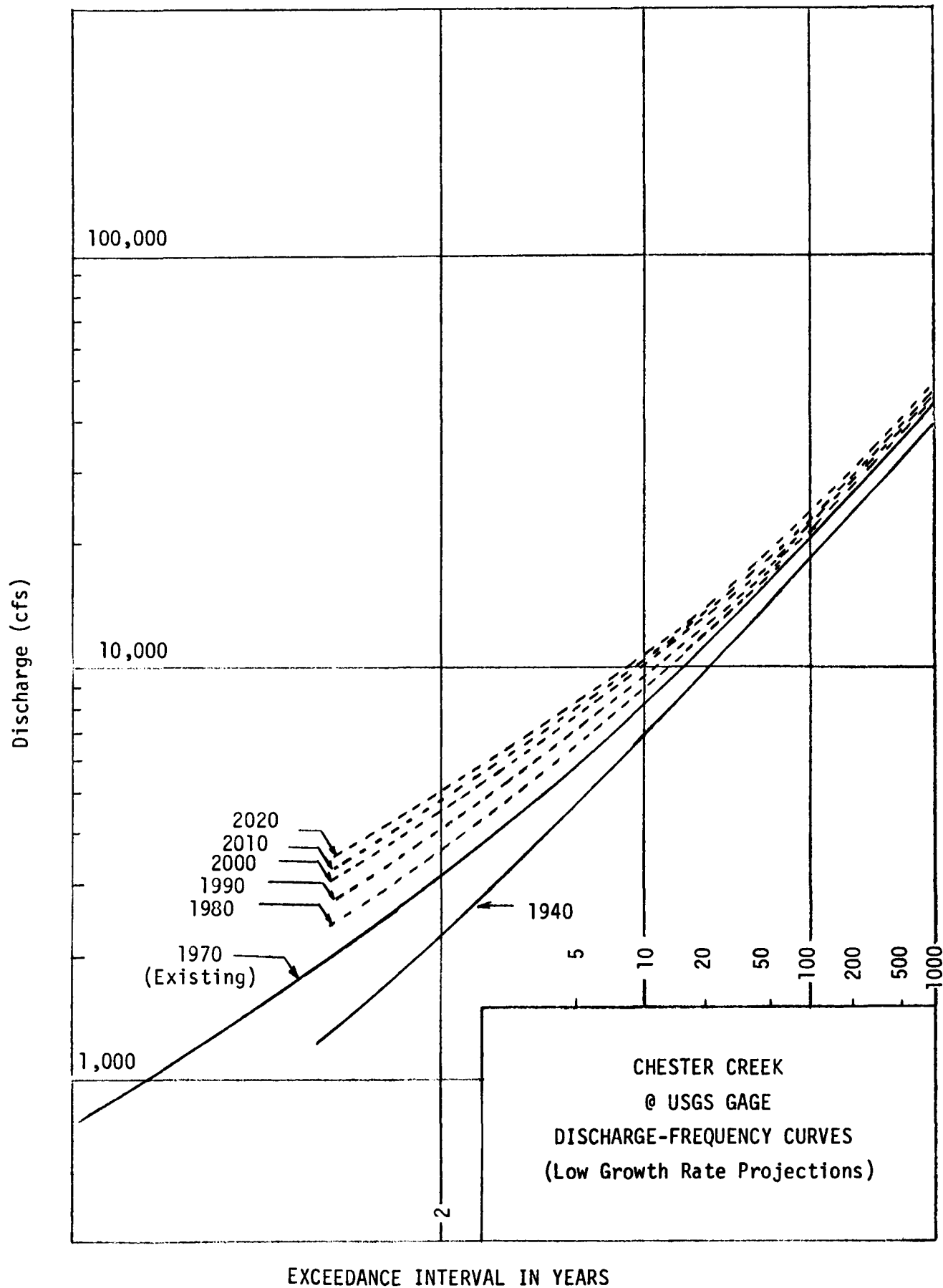


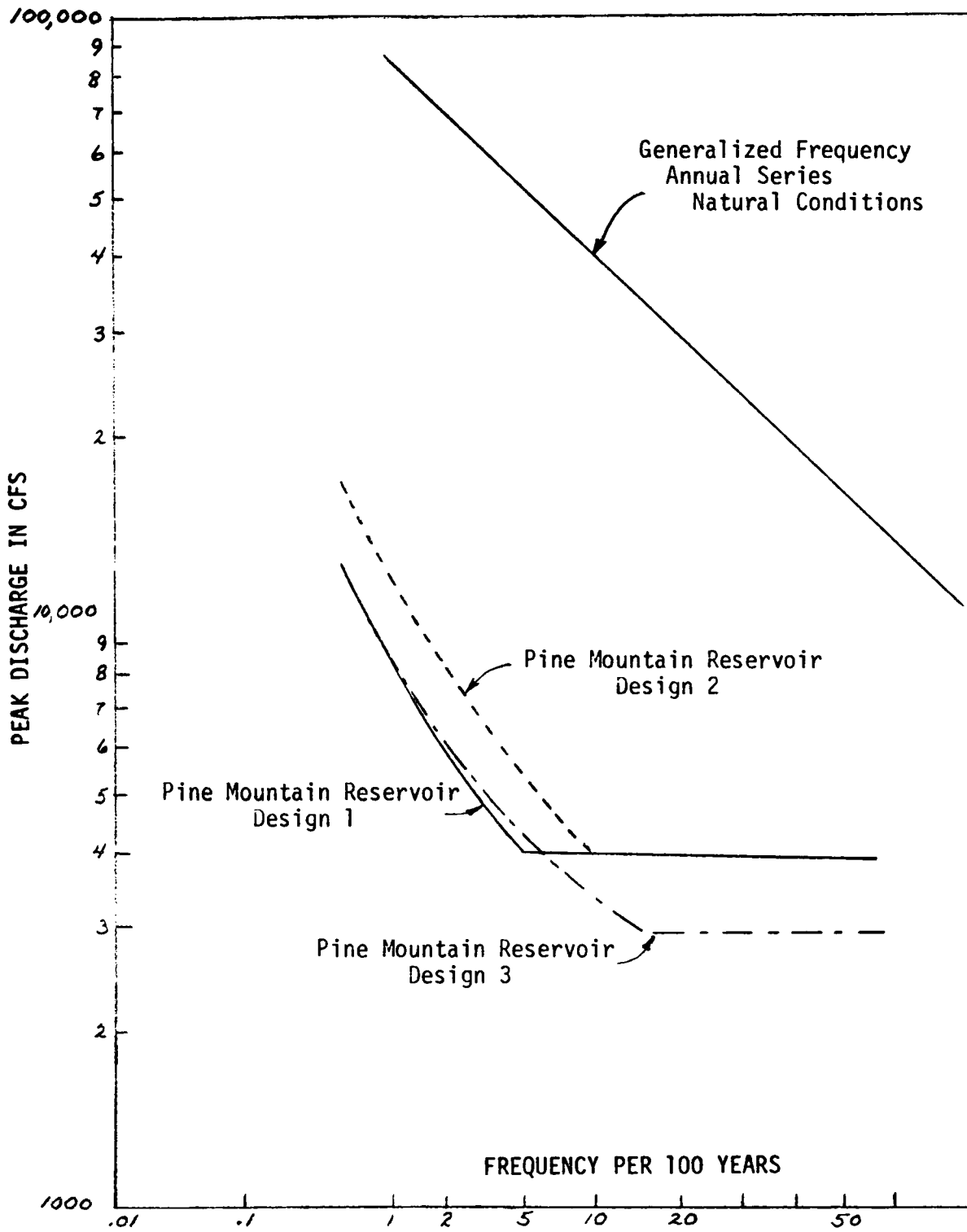
Figure 22.2

Levees and flood walls are designed to prevent flooding in areas adjacent to a river. They provide a direct means of flood protection in that they can be located where needed and can act to confine flood waters to the channel up to the design discharge. In cases where the levee or floodwall prevents flood flows from occupying areas that normally would be occupied, the river stage will be higher for a given flow. This is caused by a reduction in cross-sectional area available to carry the flood flow. Downstream, higher flood peaks can occur because valuable flood plain storage was eliminated upstream increasing the concentration of runoff. So while levees and floodwalls have the local effect of increasing the height of the channels' sides and reducing flooding at the location, they can, at the same time, effectively increase the magnitude of flow and raise the frequency curve downstream.

Channel modifications are usually designed to increase the carrying capacity of a reach of river. This is often accomplished by increasing the cross-sectional flow area by enlarging the channel; decreasing surface roughness by clearing and snagging or lining the channel; and reducing the energy loss by straightening a channel reach. All of these actions are aimed at passing flows more efficiently, that is, the conveyance area is increased or velocity increased, resulting in a lowering of river stage for a given flow. Downstream, the magnitude of flow may be greater than with the modification, that is, the magnitude of flow may increase with a given exceedance frequency event. This occurs because the channel modification may reduce roughness, reduce timing and negate natural storage effects in the channel. Actual magnitudes of change depend upon the modification and length of river reach.

Figure 22.3 shows an example of frequency distribution with and without two different volumes of reservoir storage. Also note the effect of different reservoir release rates.

Diversions: Stream diversions are another cause of changes to frequency distributions. Depending upon the magnitude of the diversion, the effect on the frequency distribution may be small or large. A diversion for flood control purposes will alter the frequency of flood flow events significantly,



**Reservoir Design**

1. FC Storage = 4.5 inches, 4,000 cfs release rate, 150' uncontrolled spillway with crest at elevation 783.0. (Adopted)
2. FC Storage = 3.5 inches, 4,000 cfs release rate, 150' uncontrolled spillway with crest at elevation 780.0.
3. FC Storage = 4.5 inches, 3,000 cfs release rate, 150' uncontrolled spillway with crest at elevation 783.0.

FLOOD DISCHARGE FREQUENCY  
LEE CREEK  
PINE MOUNTAIN DAM SITE

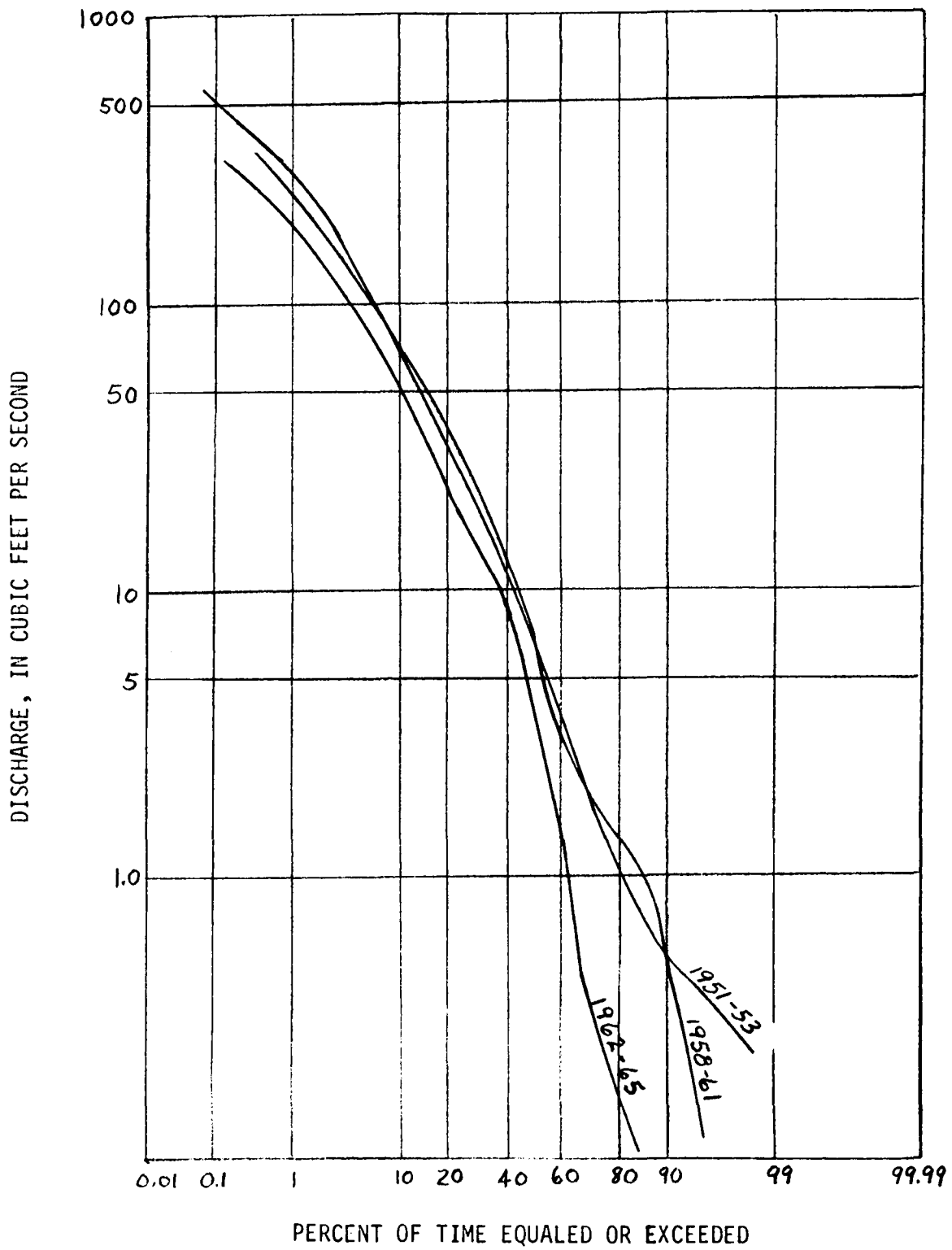
Figure 22.3

while diversions for water supply will probably have no significant effect. Conversely for low flow frequencies, diversions for water supply or any other purpose during low flow periods will probably have a measurable effect, while flood flow diversion requirements will not since they will not be used. Figure 22.4 shows the effect of gradually eliminating waste discharges into Salt Creek above Arlington. As waste treatment plants were regionalized, discharge was diverted to nearby basins and discharge was reduced over time. Figure 22.5 shows the effect of increasing low flow discharges into Salt Creek. Note that both curves are flow duration curves, which simply is the number of events greater than or equal to a certain magnitude divided by the total number of events recorded (multiplied by 100 to convert to percent time).

### Modifying Frequency Distribution

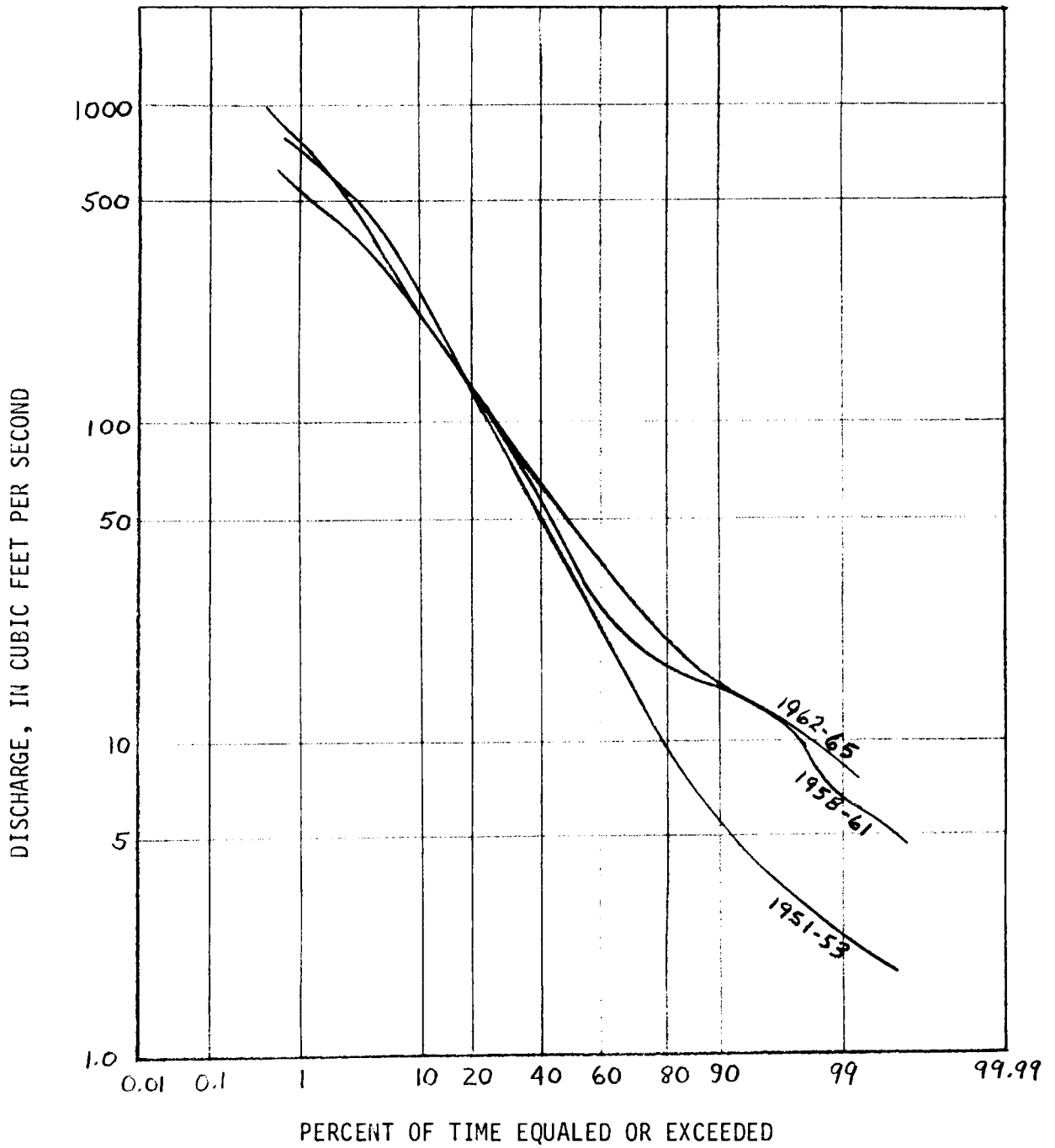
It is usually insufficient for the planner simply to acknowledge the fact that future conditions or alternative plans will modify a frequency distribution. It is necessary to actually develop the modified frequency curve. Because the planner is dealing with future conditions there is no way streamflow measurements can be used as they were in developing the curve based on past data. Thus, the question becomes how to get frequency data for future conditions. Often, the answer is by simulation of future conditions. In the past, this simulation was carried out using desk calculators and various hydrologic routing techniques. However, with the advent of the computer, sophisticated simulation models have been developed and are now widely used. Regardless of the model used, the objective is the same: input future conditions and/or alternative plans and compute the effects of the streamflow magnitude.

Watershed changes can be developed by using a hydrologic simulation model and modifying the infiltration rate of the watershed surface. The model takes rainfall data, applies it to the watershed, and computes runoff. By altering the infiltration rate, the amount of runoff changes. Infiltration rates are developed from future land use patterns over the basin, e.g., areas expected to develop as parks would have a different rate than areas expected to be residential. Probabilities are associated with



FLOW DURATION CURVE, SALT CREEK NEAR ARLINGTON HEIGHTS  
(32.5 square mile)

Figure 22.4



FLOW DURATION CURVE, SALT CREEK AT WESTERN SPRINGS  
(114 square mile)

Figure 22.5



specific runoff amounts. For example, in calibrating the model a given storm is applied to the watershed which will produce a certain peak streamflow. That peak streamflow has associated with it a certain probability of occurrence (obtained from the frequency curve developed using past records). Using the same rainfall, but different watershed conditions, a new peak streamflow is computed. The exceedance probability of this modified streamflow is assumed to be the same as with the historic (recorded) streamflow, thus one point (peak streamflow and exceedance probability) of the modified frequency curve has been determined. Using additional runoff amounts, additional points can be computed.

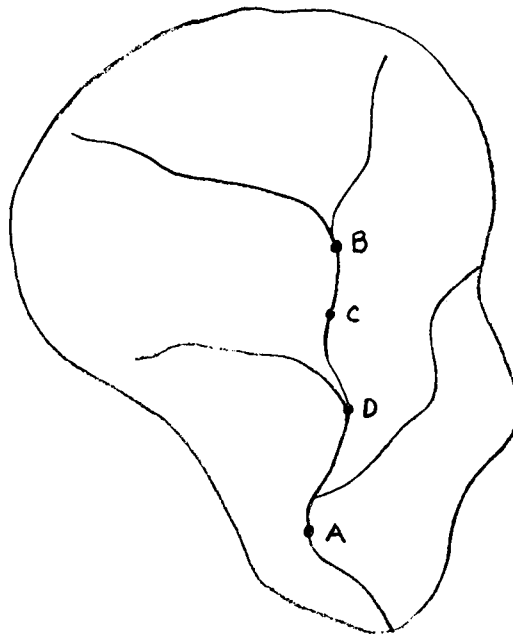
For reservoirs and other storage facilities, simulation models are available which simulate the streamflow at selected locations in the watershed. The reservoir or storage facility characteristics (elevation-area-volume, release rate, operating criteria) are specified and the system simulated using a range of hydrographs with peak events of known exceedance probability. With the storage facility in, the magnitude of streamflow at locations downstream is computed, and it together with the associated probability becomes the data to define the modified curve.

Levees and channel modifications affect the storage available along the stream itself. This is computed in terms of modified routing criteria. For example, if the channel is modified between points A and B, new routing criteria can be developed using storage outflow curves. This involves making water surface profile computations for known flows and computing the associated storage in the channel for each flow. Changes to the channel or flood plain land would be reflected in the storage available for a known flow. Routing the inflow hydrograph through the channel reach with the modified routing criteria will yield modified streamflow at downstream points. The associated frequency is known from the unmodified frequency distribution.

Diversions are handled in much the same way as reservoirs - by simulating the operation of the system with known hydrologic inputs and the diversion.

QUESTIONS  
CHAPTER 22  
DEVELOPMENT EFFECTS OF FREQUENCY CURVES

1. Analyze the preproject and project frequency curves shown in Figure 22.6. Explain the type of development which could create each curve.
  
2. Given the basin shown below and the natural condition frequency curve, stage-discharge curve, and stage-damage curves in Figures 22.7-22.15, show how each curve is normally modified when the following development occurs.
  - a. Urbanization of basin land.
  - b. Reservoir construction upstream at B.
  - c. Construction of a flood by-pass at D (return below A).
  - d. Levee construction from location C to D.
  - e. Channel enlargement from C to D.
  - f. Operation of a flood forecasting system.
  - g. Flood proofing of all structures at location A.
  - h. Evacuation of all structures at location A.



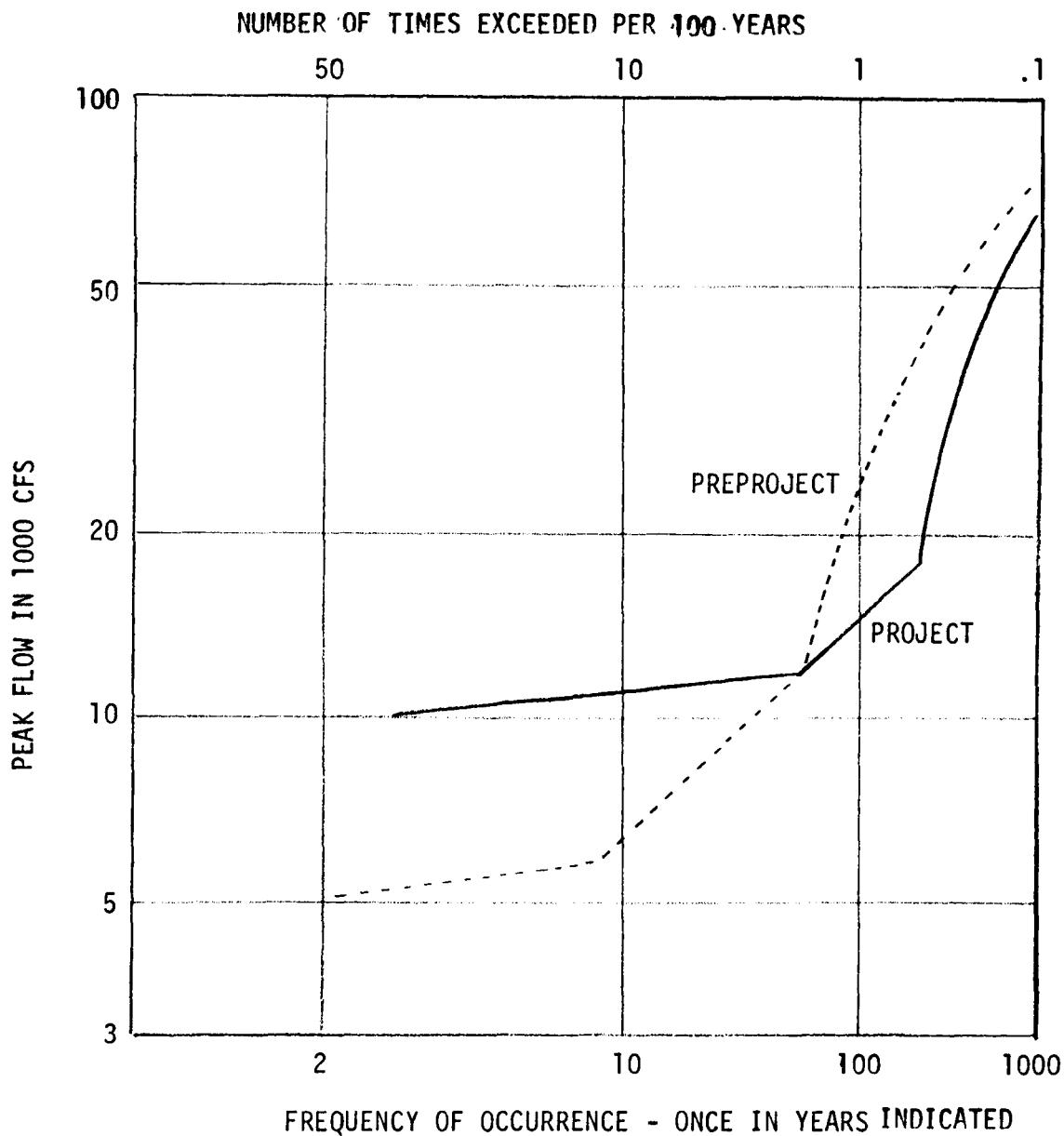
DISCUSSION OF QUESTIONS  
CHAPTER 22  
DEVELOPMENT EFFECTS ON FREQUENCY CURVES

1. The preproject frequency distribution is for the location with New Hogan Reservoir upstream and a downstream nondamaging channel capacity of 6,000 cfs.

The project curve represents the expected frequency curve if the channel capacity were enlarged to 12,500 cfs.

What the two relationships show is that by enlarging the channel a flow of 11,500 cfs can be expected to be exceeded once in 20 years while under preproject conditions this magnitude is 8,800 cfs.

2. See Figures 22.7-22.15.

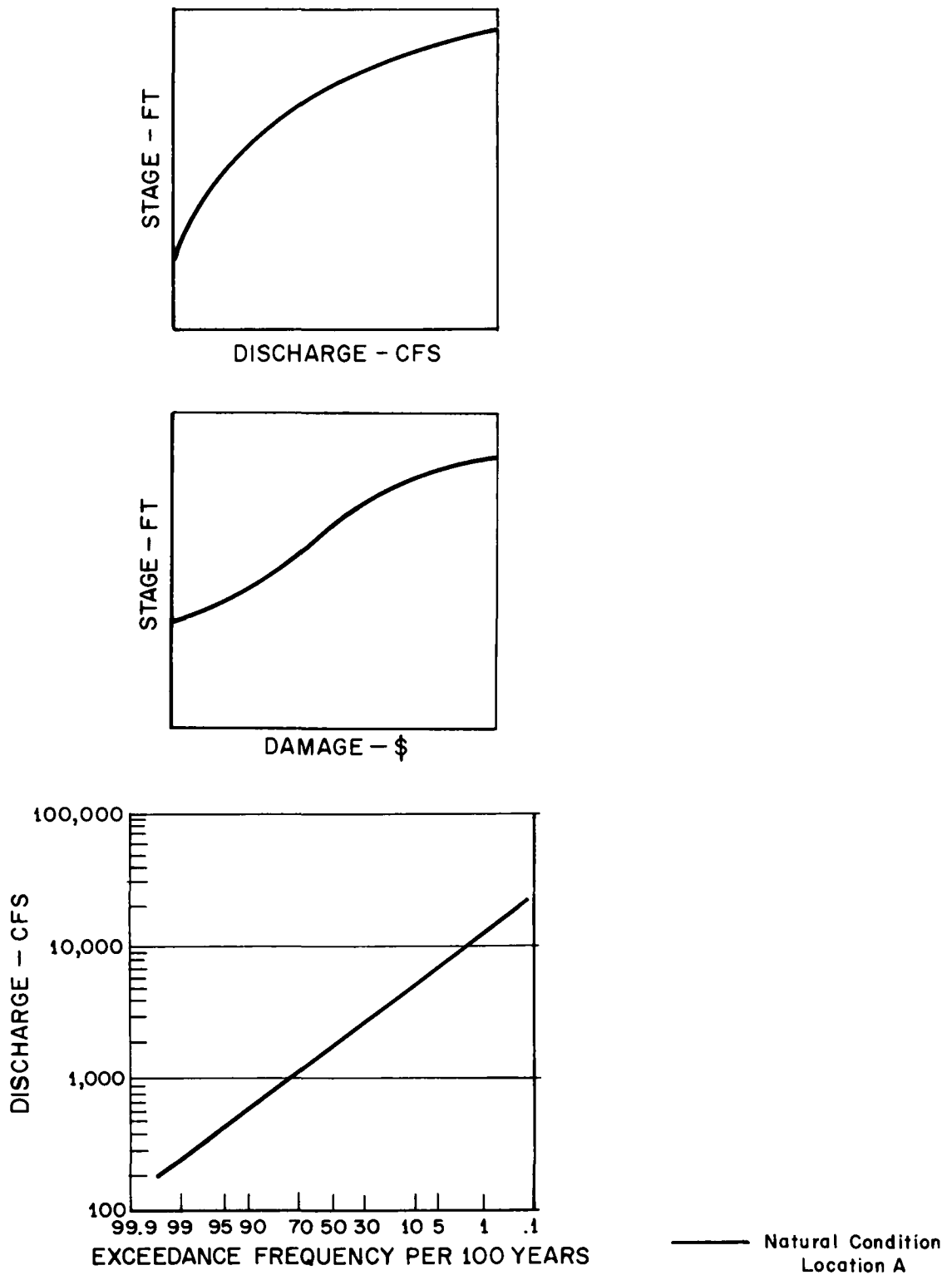


LEGEND

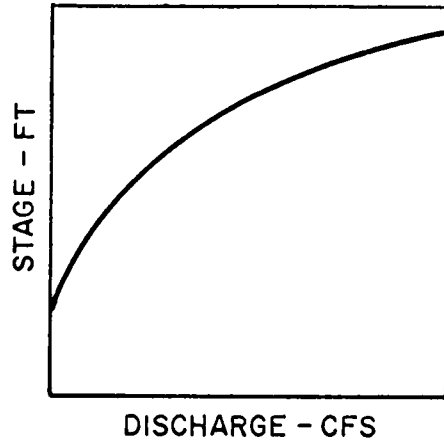
- 165,000 acre-foot flood control reservation in New Hogan
- - - - - Preproject, objective flow of 6,000 cfs at Bellota
  - Project, objective flow of 12,500 cfs at Bellota

Mormon Slough  
 Calaveras River, California  
 FREQUENCY OF PEAK FLOWS  
 AT BELLOTA  
 (Downstream from New Hogan Reservoir)

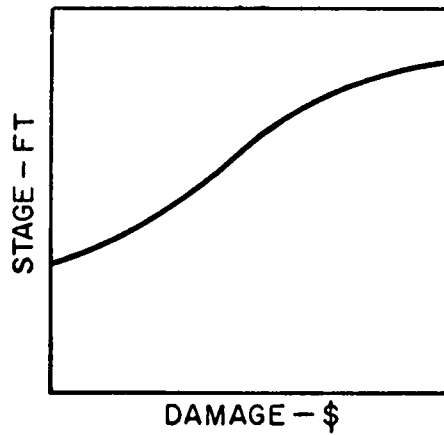
Figure 22.6



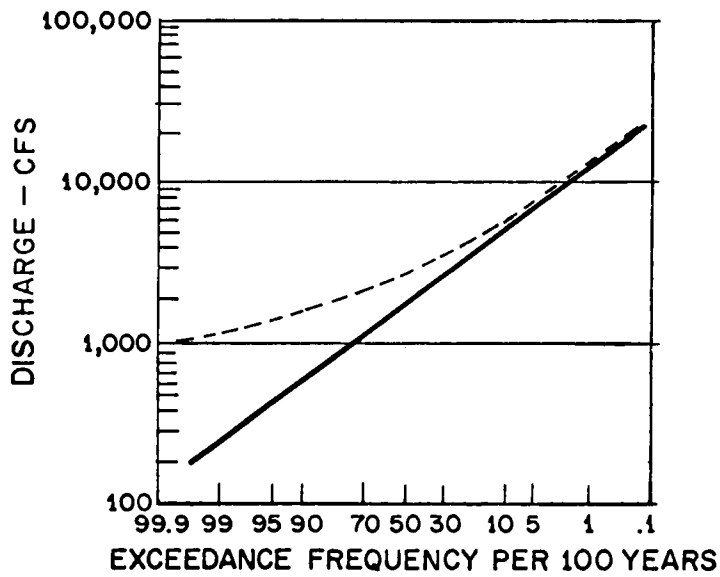
**Figure 22.7 HYDROLOGIC DATA FOR NATURAL CONDITIONS**



No Change



No Change

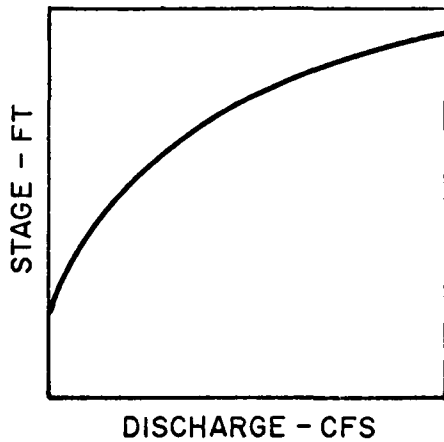


Increase in runoff for exceedance frequencies.

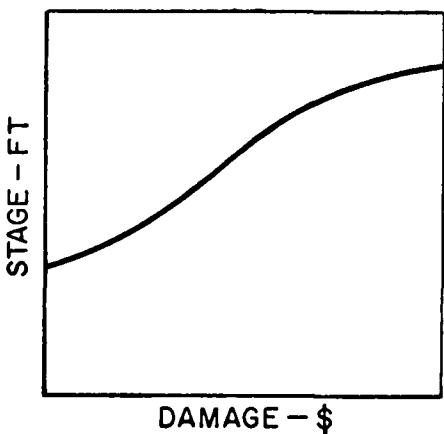
— Natural Condition  
Location A

- - - Modified Condition  
Location A

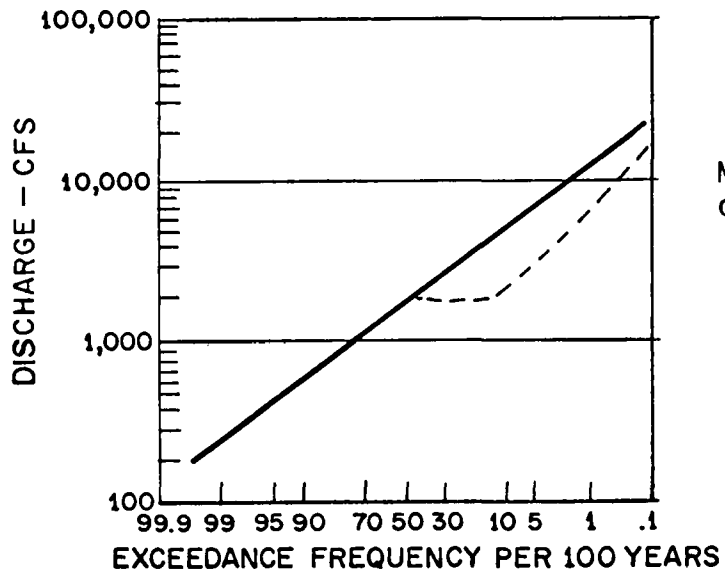
Figure 22.8 HYDROLOGIC DATA WITH URBANIZATION



No Change



No Change

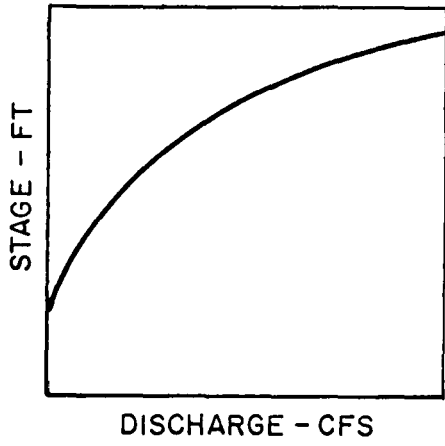


Minimum flow release  
of 2000 cfs.

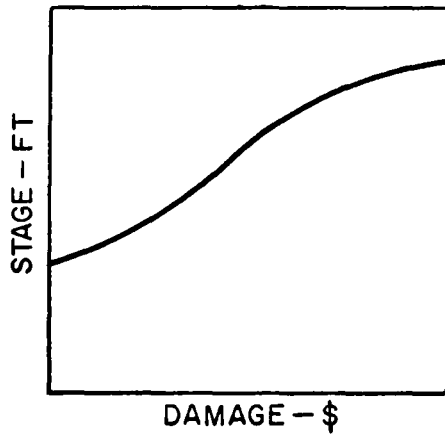
Reservoir at B

- Natural Condition Location A
- - - Modified Condition Location A

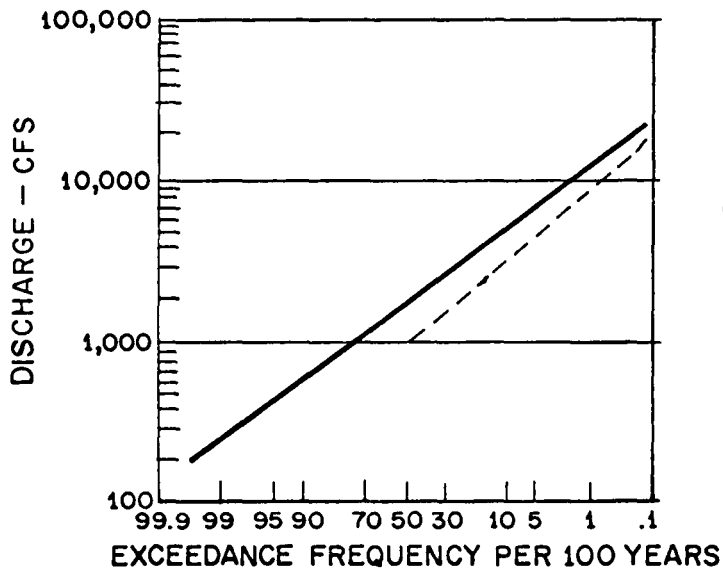
Figure 22.9 HYDROLOGIC DATA WITH RESERVOIR REGULATION



No Change



No Change

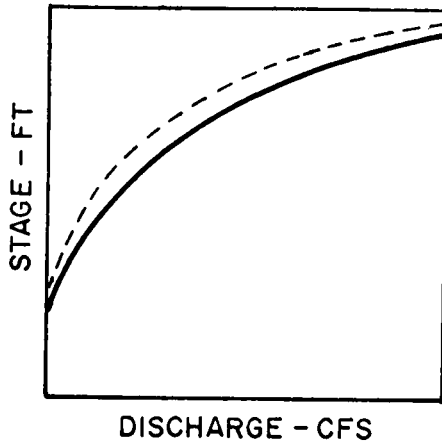


By-pass becomes operative at 1,000 cfs.

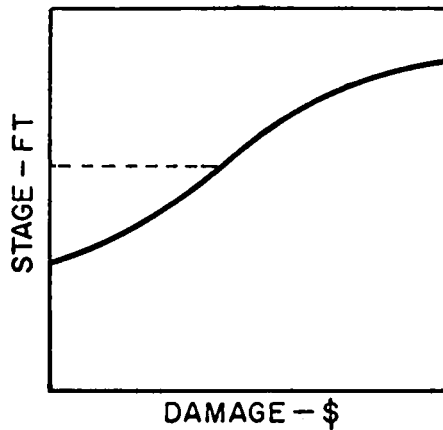
— Natural Condition Location A  
 - - - Modified Condition Location A

Figure 22.10 HYDROLOGIC DATA WITH FLOOD BY-PASS

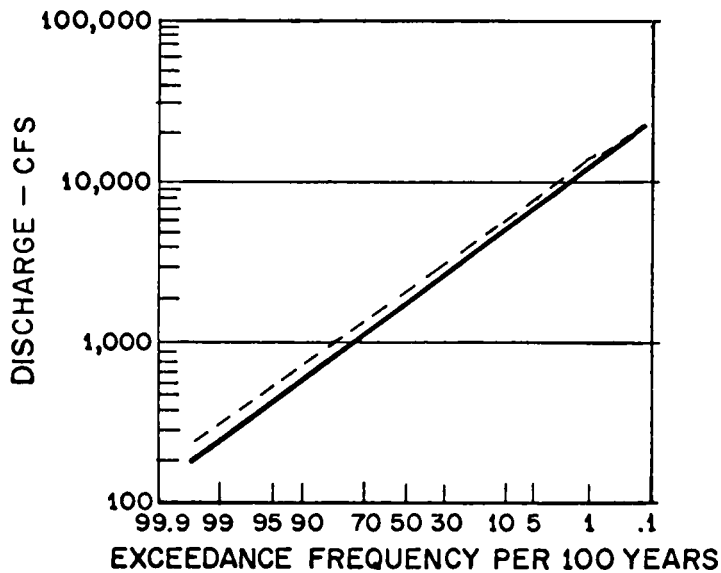




Levee construction will alter the Stage-discharge relationship from C to D, but not at A.



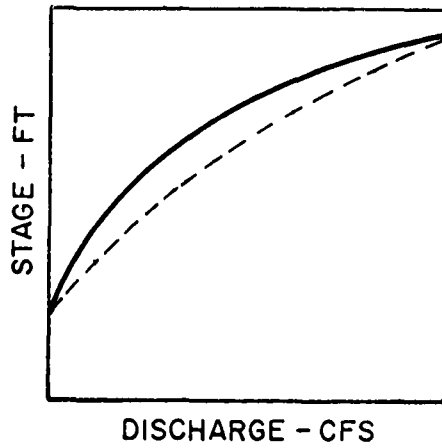
Levee Construction will truncate the Stage-damage relationship from C to D, but not at A.



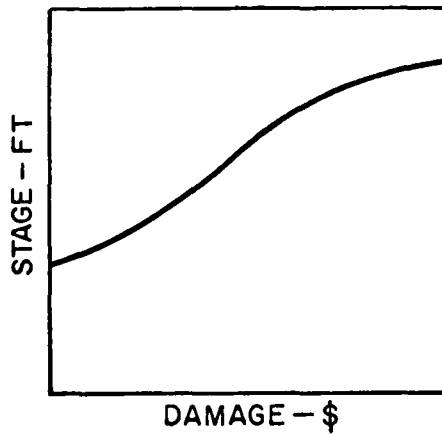
Levee Construction may alter the discharge-frequency relationship below the levee reach.

— Natural Condition Location A  
 - - - Modified Condition Location A

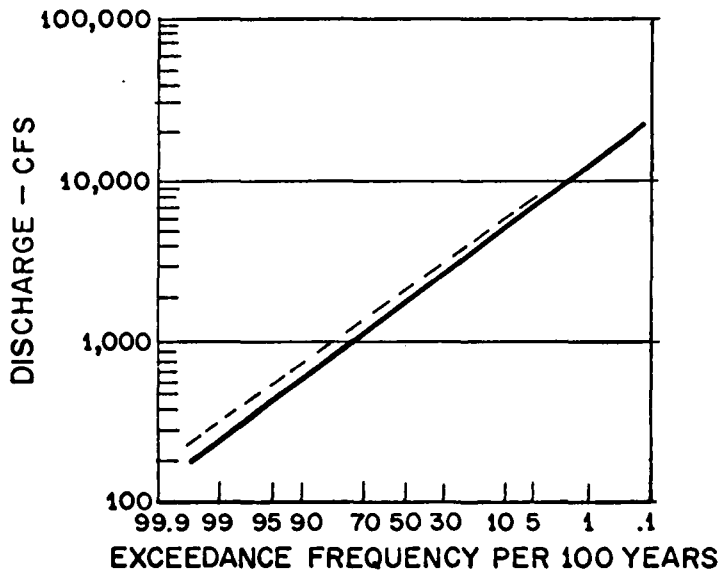
Figure 22.11 HYDROLOGIC DATA WITH LEVEE CONSTRUCTION



Channel enlargement will alter the Stage-discharge relationship from C to D, but not at Location A.



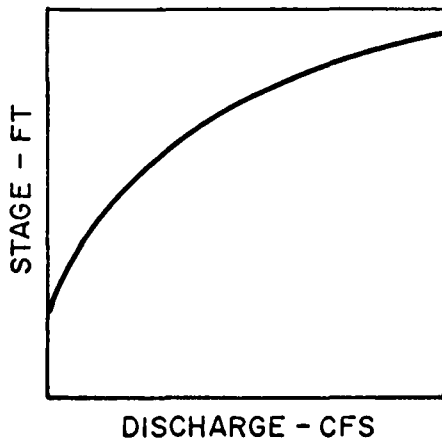
No Change



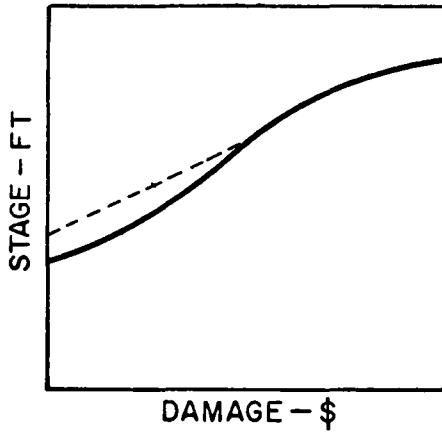
Channel enlargement will alter discharge-frequency relationship below enlarged reach.

— Natural Condition Location A  
 - - - Modified Condition Location A

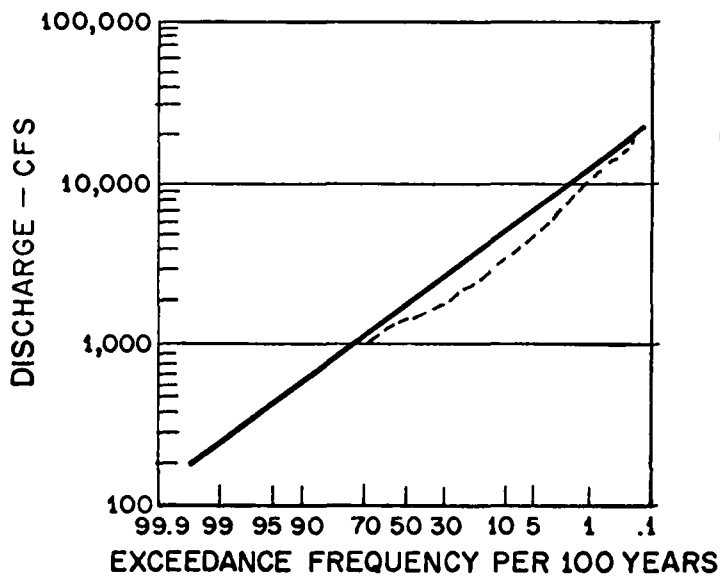
Figure 22.12 HYDROLOGIC DATA WITH CHANNEL ENLARGEMENT



No Change



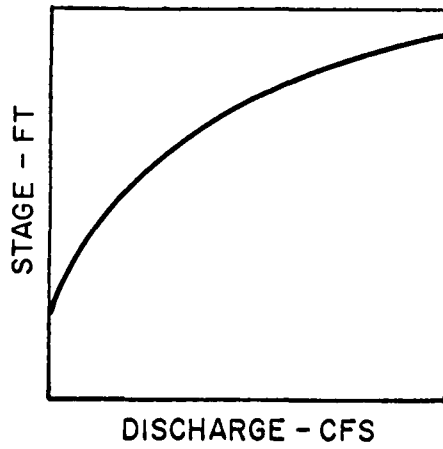
Forecasting can only be effective if damageable property is protected or flood flows controlled. To control floods a reservoir or other control structure must be operated. To protect property a warning must be issued.



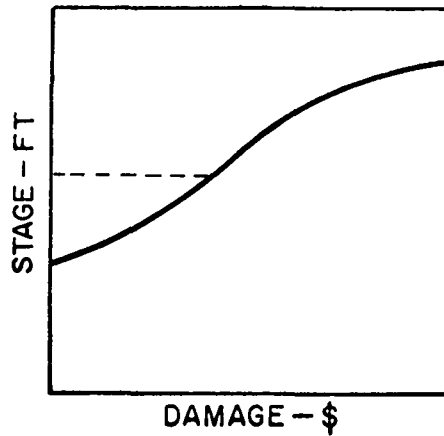
Control of flood flows by reservoir operation.

— Natural Condition Location A  
 - - - Modified Condition Location A

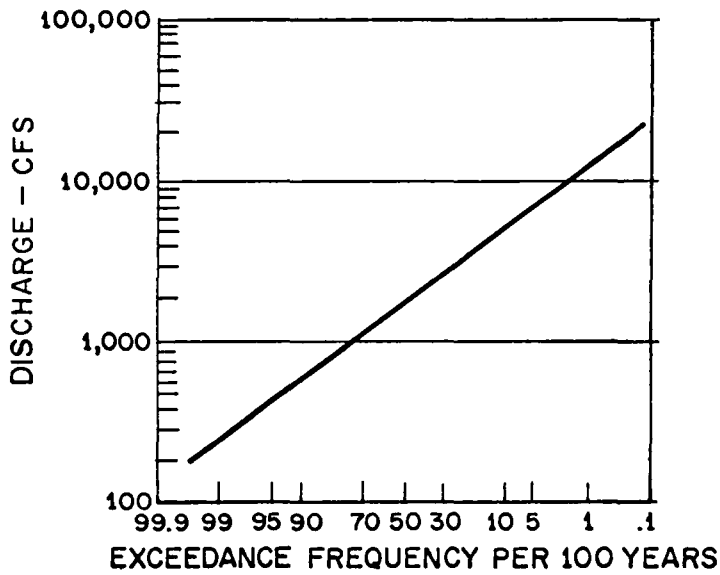
Figure 22.13 HYDROLOGIC DATA WITH FORECAST WARNING



No Change



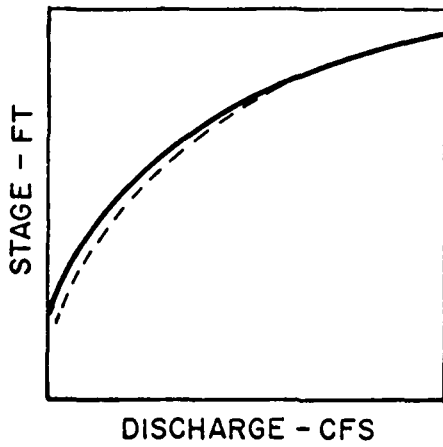
Damages below the level of protection of flood proofing are prevented.



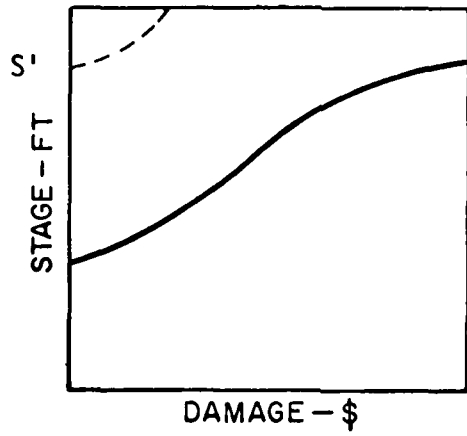
No Change

— Natural Condition  
Location A  
- - - Modified Condition  
Location A

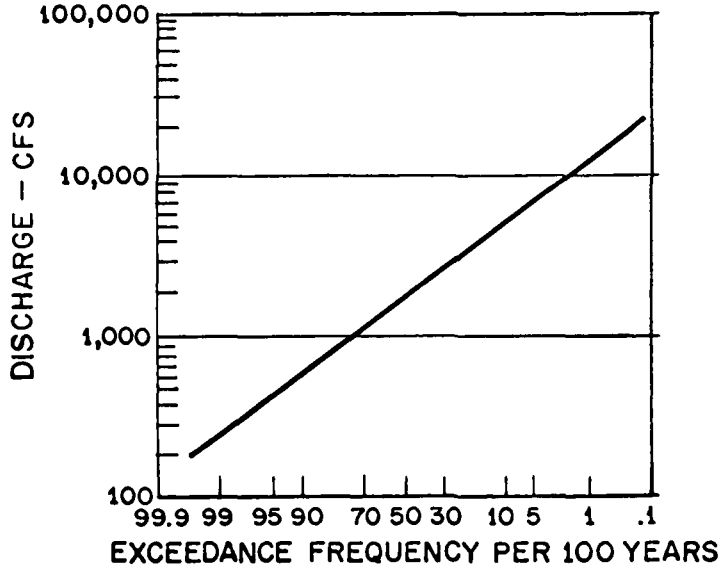
Figure 22.14 HYDROLOGIC DATA WITH FLOOD PROOFING



Removal of the structures may lower the stage.



Damages below elevation S' are eliminated. Damages above are assumed to occur.



No Change

- Natural Condition Location A
- - - Modified Condition Location A

Figure 22.15 HYDROLOGIC DATA WITH RELOCATION

CHAPTER 23  
USE OF FREQUENCY CURVES IN PLANNING

Introduction

Frequency relationships have many uses in water resources planning. They are used in sizing of water facilities (spillways, levees, etc.), in establishing water resource regulations, and in computing expected values. Each of these will be discussed in more detail below.

Sizing Facilities

In sizing facilities it is usually desirable to know what magnitude of event should be used given a specific frequency of occurrence. Alternately, given a specific magnitude of event what frequency of occurrence can be expected? For example, in the first case if it is desired to protect for the 50-year flood, what flow can be expected? Or in the latter case if 10,000 cfs is the maximum flow which can be handled, what level of protection can be expected? In either case the distribution is entered with the known value and the corresponding value determined. Often design frequencies or a range of frequencies are specified by Corps regulations. Table 23.1 shows a summary of some of these values for flood control measures.

Establishing Regulations

"Flood plain area having special flood hazards means that maximum area of the flood plain that, on the average, is likely to be flooded once every 100 years (i.e., that has a 1 percent chance of being flooded each year)." FIA regulations 1971, Subpart A 1901.1.

The above regulation is an example of how frequency distributions are needed for establishing various water resource regulations. The special flood hazard area mentioned can be delineated by selecting from the frequency distribution for a particular location the magnitude of the 100-year event. Using water surface profile computation procedures, the water surface elevation can be computed and plotted on a topo map to delineate the area.

**Table 23.1**  
COMMONLY USED DESIGN FREQUENCIES

<u>Facility</u>	<u>Recurrence Interval, years</u>
	<u>Range</u>
Flood Control <sup>1</sup>	
Reservoir	50 - SPF
Spillway (High dams)	PMF
Levee	10 - SPF
Channel	5 - SPF
Drainage	1 - 50
Hurricane Protection	10 - SPH
Urban Storm Drains <sup>2</sup>	10 - 25
Initial Design	2
Residential	5
High Value General Commercial Area	5
Public Building Area	10
High Value Downtown Business Areas	5 - 10
Major Design	100
M&I Water Supply	20 - 100

---

<sup>1</sup> Corps of Engineers, "Digest of Water Resources Policies and Activities," EP 1165-2-1, January 1975.

<sup>2</sup> Denver Regional Council of Governments, "Urban Storm Drainage Criteria Manual, Volume 1, 1969.

Regulations are also established for minimum flow conditions using low flow frequency distributions.

### Computing Average Values

It was pointed out in Chapter 16 that one characteristic of a frequency distribution, which relates magnitude of events to probability of occurrence, is that the area under a graphical plot of this relationship is the "average" or "expected" value.<sup>1</sup> That is to say, each event is weighted (multiplied) by its respective probability of occurrence and the resulting summation of this product over the entire range of probability is its average (weighted) value. This fact has many uses in planning with the most common being to compute average annual damages. By combining a flow-frequency relationship with a flow-damage relationship the resulting damage-frequency function can be integrated resulting in a value equal to the average damages. Figures 23.1, 23.2, and 23.3 and Table 23.2 show an example of this use. It should be kept in mind that all one is doing is weighting each damage value or event by its associated probability. Thus, the average value is the average for a specific frequency relationship. Should the relationship change, the average would change. This is important when considering frequency distributions over time. For example, a frequency distribution developed using today's land use may change in the future as the watershed is urbanized. If a frequency distribution is developed to represent land use in year 2000, then the average value of damages will be different in the future than what it is now. To find average damages for all years over a particular planning horizon, each year's average must be discounted back to the present (since dollars have a time value) and amortized. The resulting value is usually referred to as the "equivalent" annual value. For values other than dollars, say, magnitudes of flow, the average for the periods would simply be the weighted average (each year's average value being weighted by the number of years which it occurs). Only in the case of dollars are each year's values discounted back to the present. These concepts are illustrated below.

---

1 In water resources engineering literature the value computed by the integration of a frequency function is commonly referred to as the "average" value. In statistical literature the term "expected" is common.



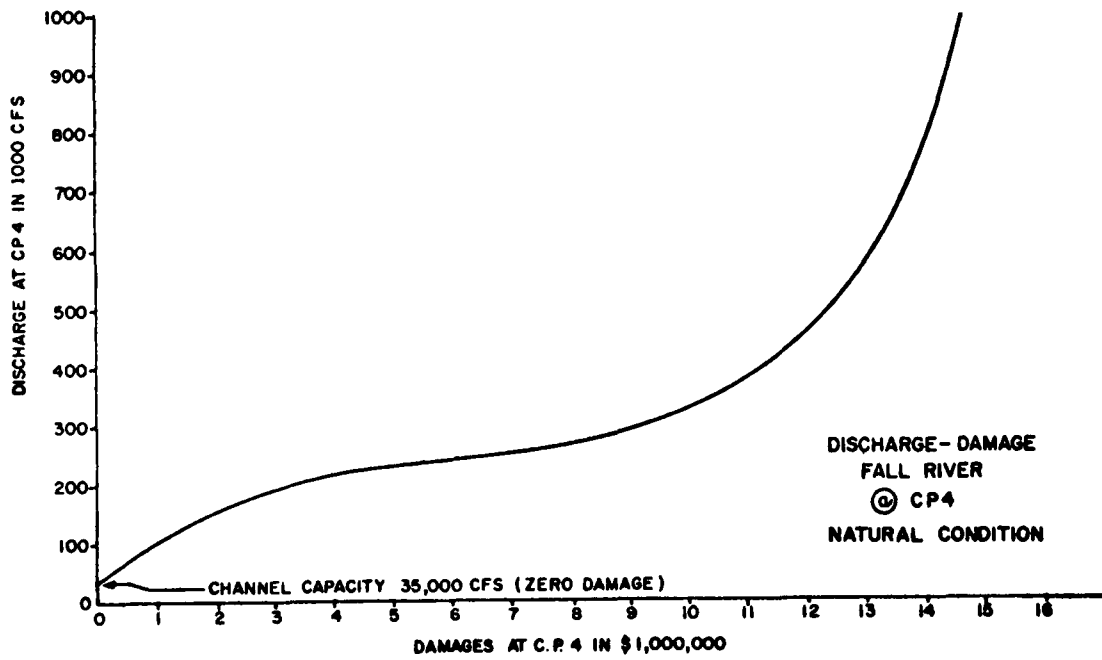


Figure 23.1 DAMAGE DISCHARGE CURVE

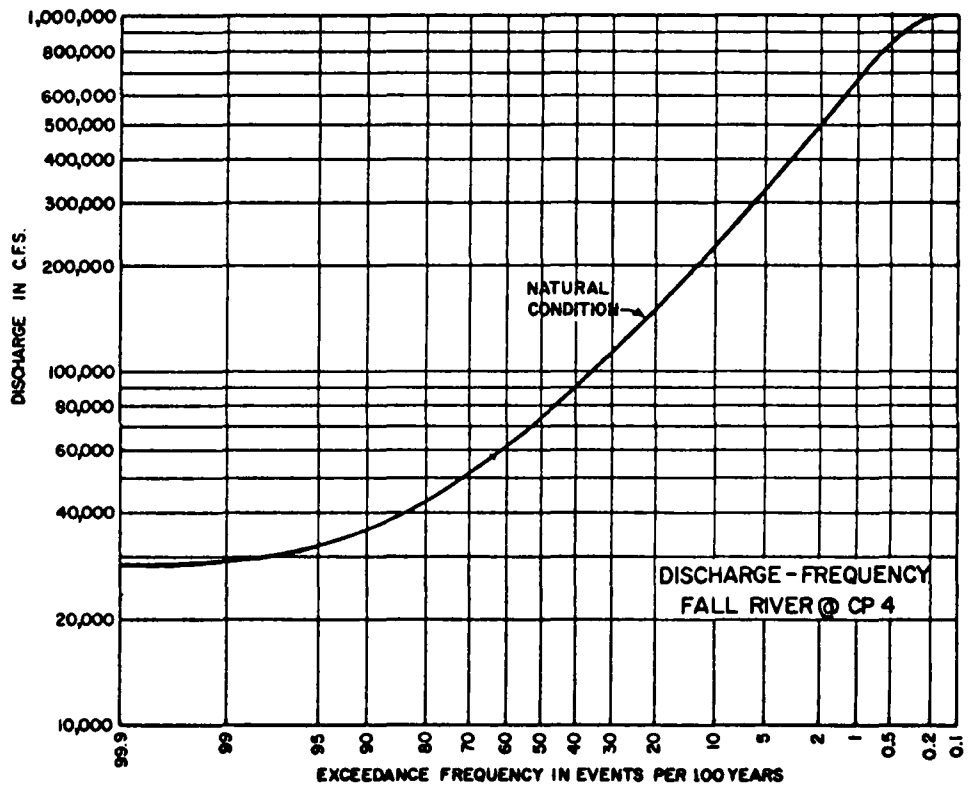
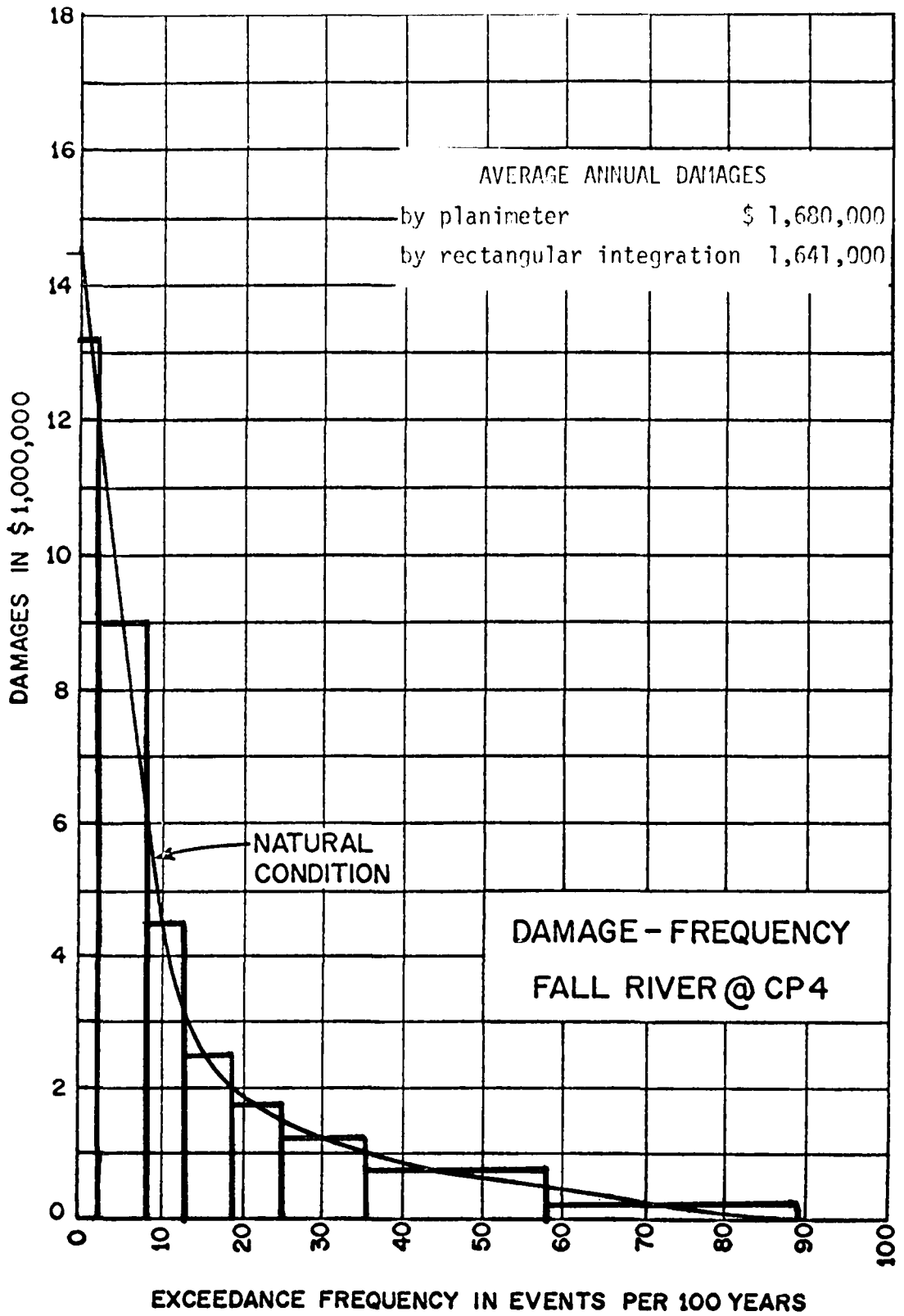


Figure 23.2 DISCHARGE FREQUENCY CURVE



**Figure 23.3 DAMAGE FREQUENCY CURVE**

Table 23.2

COMPUTATION OF AVERAGE ANNUAL VALUES

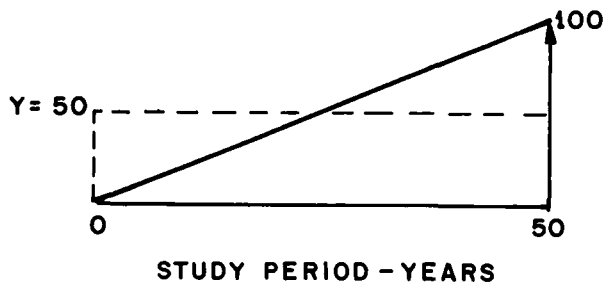
$D \text{ (x } 10^6)$	$\frac{D_1+D_2}{2}$	P	$P_2-P_1$	$\frac{D_1+D_2}{2} \times (P_2-P_1)$	$\Sigma$
14.5		0			0
	13.25		.02	.265	.265
12.0		.02			
	9.0		.06	.540	.805
6.0		.08			
	4.5		.05	.225	1.030
3.0		.13			
	2.5		.06	.150	1.180
2.0		.19			
	1.75		.06	.105	1.285
1.5		.25			
	1.25		.09	.113	1.399
1.0		.36			
	.75		.22	.165	1.563
.5		.58			
	.25		.31	.078	1.641
0		.89			

Average Annual Damage = \$1,641,000

Notation

D = Damage Value from Figure 23.3

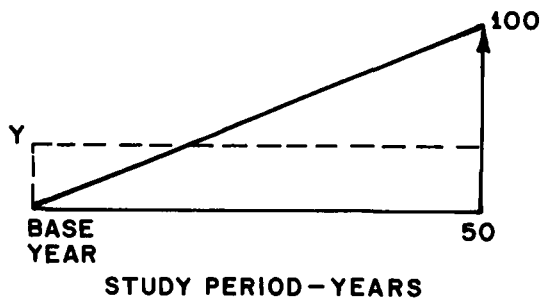
P = Probability Value from Figure 23.3



NON-ECONOMIC VALUES

AVERAGE VALUE IN YEAR 50 = 100

EQUIVALENT ANNUAL VALUE = Y = 50



ECONOMIC VALUES

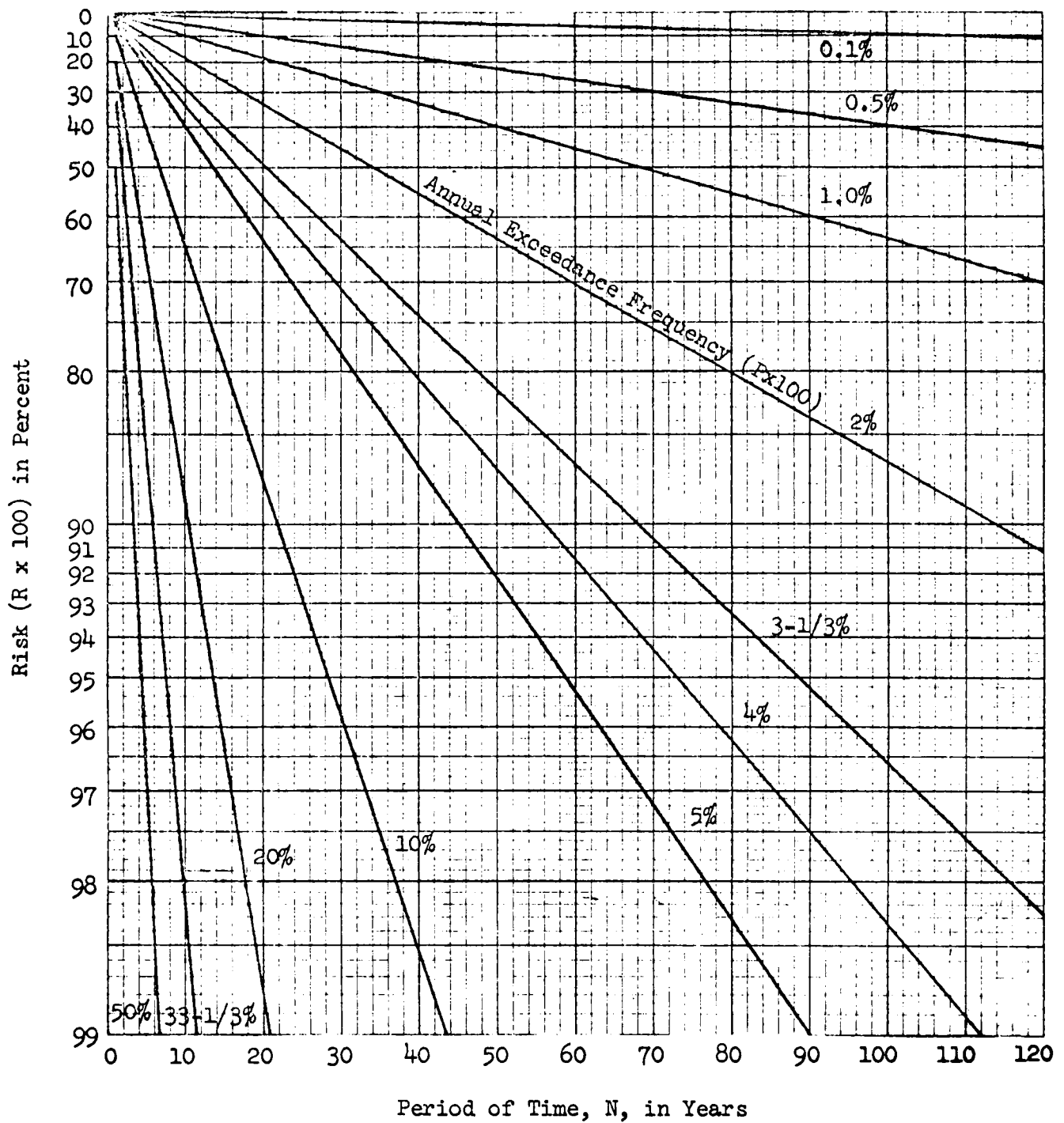
AVERAGE DAMAGES IN YEAR 50 = 100

EQUIVALENT ANNUAL DAMAGES

	<u>i=0%</u>	<u>i=5%</u>	<u>i=10%</u>
Y	50	32.4	21.1

Risk

Risk is defined as "the probability that one or more events will exceed a given flood magnitude within a specified period of years". This differs from the exceedance probability of the frequency distribution in that the exceedance probability is for "on the average" conditions, that is, any one year, while the risk probability applies to a specific number of years. As an example, a flood with an .01 exceedance probability can also be described as a flood with a 1% chance of exceedance during the next year. If instead of any one year we want to know the risk or percent chance of exceedance during the next 30 years, this value is determined using Figure 23.4 - the value is 25%. Risk analysis is an important use of frequency data because it reflects the higher probability associated with a period shorter than "on the average".



RISK OF ONE OR MORE FLOOD EVENTS EXCEEDING  
A FLOOD OF GIVEN ANNUAL EXCEEDANCE FREQUENCY WITHIN A PERIOD OF YEARS

Figure 23.4

QUESTIONS  
CHAPTER 23  
USE OF FREQUENCY CURVES IN PLANNING

1. How could frequency distribution confidence limits be used when sizing facilities and establishing regulations?
2. How are average yearly values computed for flood damages and peak streamflow using frequency data?
3. Given a stream of average flood damages and average peak streamflows over time, e.g., planning period, how is the average of each year's values computed?
4. When should "risk" be computed and used in planning?

DISCUSSION OF QUESTIONS  
CHAPTER 23  
USE OF FREQUENCY CURVES IN PLANNING

1. For sizing, by knowing the desired protection level, say 50 year, a magnitude can be determined. The upper and lower confidence limits also have associated with them frequencies and magnitudes. Using the upper and lower magnitudes instead of the desired one the planner can compare the required facility size with what was determined using a frequency curve value. Adjustments may then be feasible to insure an adequate facility size is selected.
2. By multiplying (weighting) each damage or streamflow magnitude by its corresponding probability of occurrence and summing all products.
3. Average damages are computed by discounting each year's value to the base year and amortizing the present value over the planning period.

Average streamflows are computed by summing each year's streamflow and dividing by the number of years.

4. Risk should be computed and stated in planning studies whenever it is important to show what the probability of occurrence is for a specified period.

INTRODUCTION TO RESERVOIR YIELD STUDIES



CHAPTER 24  
RESERVOIR YIELD STUDIES

General Aspects of Reservoir Yield Analysis

Low flow analysis encompasses evaluation of streamflow during the portions of the runoff period when surface runoff is essentially nonexistent. While the ultimate source of low flow is precipitation, its primary source is water derived from basin storage such as groundwater or soil moisture storage. The controlling mechanisms and objectives of analysis are sufficiently different from those encountered in storm runoff. As a result, quite different analysis techniques are usually applied. The purpose of this chapter is to discuss the control and management of flows to achieve objectives rather than to describe its nature.

- o Time Scale -- The time scale associated with low flow analysis is generally on the order of weeks and months in comparison to storm flows where days or even smaller time units are usually appropriate. Consequently, the time lag between points in the stream system and the natural surface valley storage is of relative unimportance. The volume of flow, usually represented by an average rate for a specific time, is of the most interest in reservoir yield analysis.
  
- o Flow Components - Components of the hydrologic system that were neglected in stormwater runoff such as evaporation, transpiration, channel infiltration, and base flow are of paramount importance during low flow periods. Low flow analysis is principally concerned with the base flow condition.
  
- o Low Flow Studies - Low flow analysis is required when planning for "reservoir yield" type uses of the water resource. Investigations are concerned with water supply, hydropower, and water quality. Low flow analysis can be divided into two broad areas: descriptive, which refers to the characterization of flow in statistical or other terms, and operation, which is concerned with reservoir yield type studies.

## Statistical Aspects of Low Flow

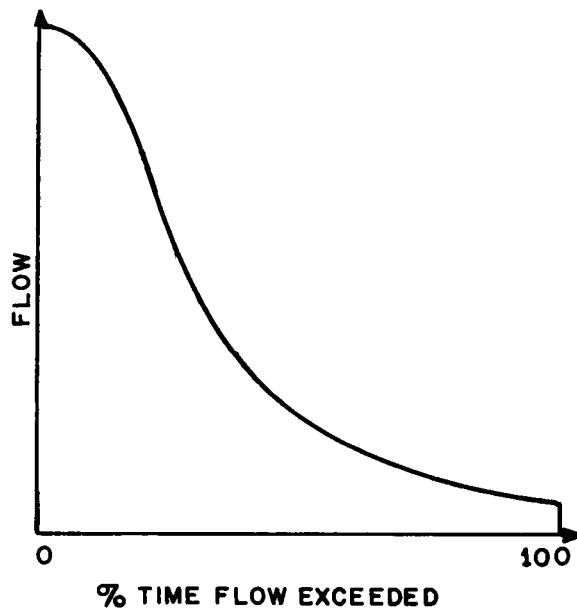
Streamflow during low flow periods can be characterized statistically by non-exceedance frequency curves and duration curves. There is a tendency to confuse the two relationships. A frequency curve indicates the percent chance in a specific time period of a certain flow not being exceeded whereas a duration curve indicates the percent of time, that the recorded streamflows have been exceeded. The duration curve is used extensively in hydropower screening studies. The low flow frequency curves are often used in water supply studies. Figure 24.1 illustrates the difference between duration and frequency curve.

- o Low Flow Frequency Relations - The techniques for development of low flow, non-exceedance frequency curves are very similar to development of peak flow exceedance frequency curves. However, care should be taken to properly interpret the curve. The curve indicates the probability of an average flow of a specified duration not being exceeded within a year. Interpreting non-exceedance frequency curves for durations exceeding one year causes conceptual problems.

Low flow frequency curves are generally plotted on log-normal probability paper, using a plotting point equation. The appropriate distribution has not yet been determined. Because of the variability of causative factors, it is doubtful a theoretical distribution will be found that is generally applicable. One problem that has been encountered is that low flows can originate from a number of sources depending upon the time of year or flow conditions. This means the "sample population" is probably mixed causing theoretical problems. For instance, the source of groundwater contributing to streamflows may originate from different aquifers depending on the time of the year, resulting in different populations of flows. Figure 24.2 contains a sample of low flow frequency curves indicating the great variability and lack of consistency.

Regional analysis of low flow frequency information is generally unsuccessful with some specific exceptions. The failure results from a

DURATION CURVE



NON-EXCEEDENCE FREQUENCY CURVE

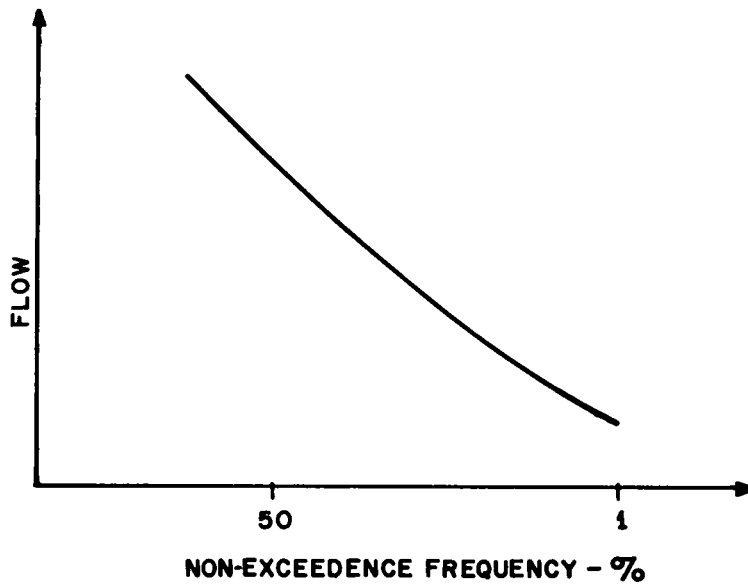
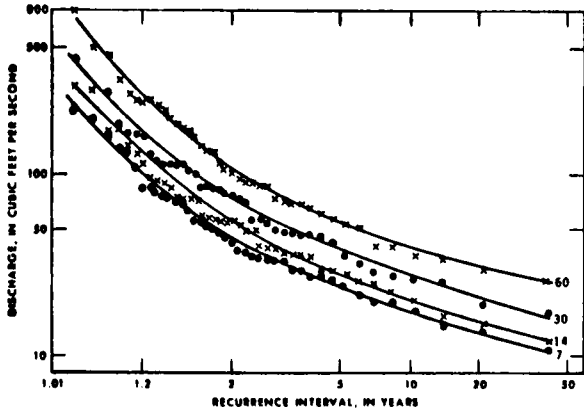
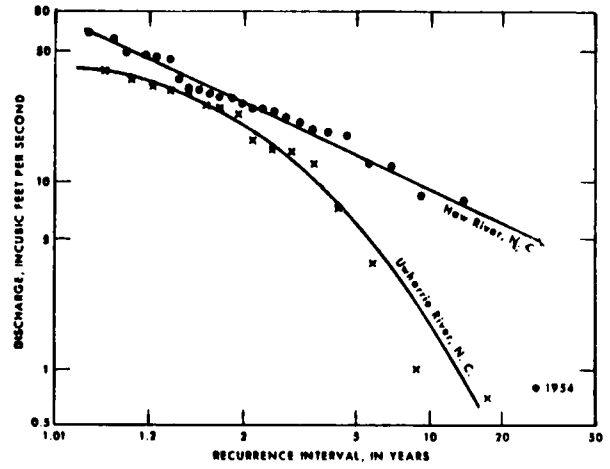


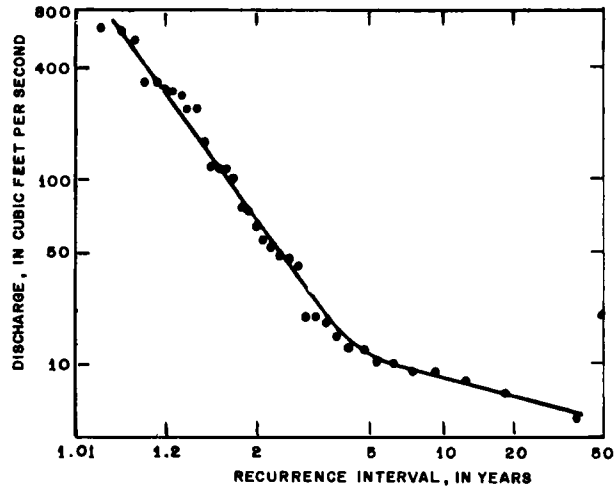
Figure 24.1 FLOW DURATION AND FREQUENCY CURVES



—Typical frequency curves of annual lowest mean discharge for indicated numbers of consecutive days, Spoon River at Seville, Ill.



—frequency curves of annual minimum 7-day means showing effect of diversions.



Low-flow frequency curve (of annual minimum 7-day means) for Suwannee River at White Springs, Fla.

**Figure 24.2 LOW FLOW FREQUENCY CURVES**

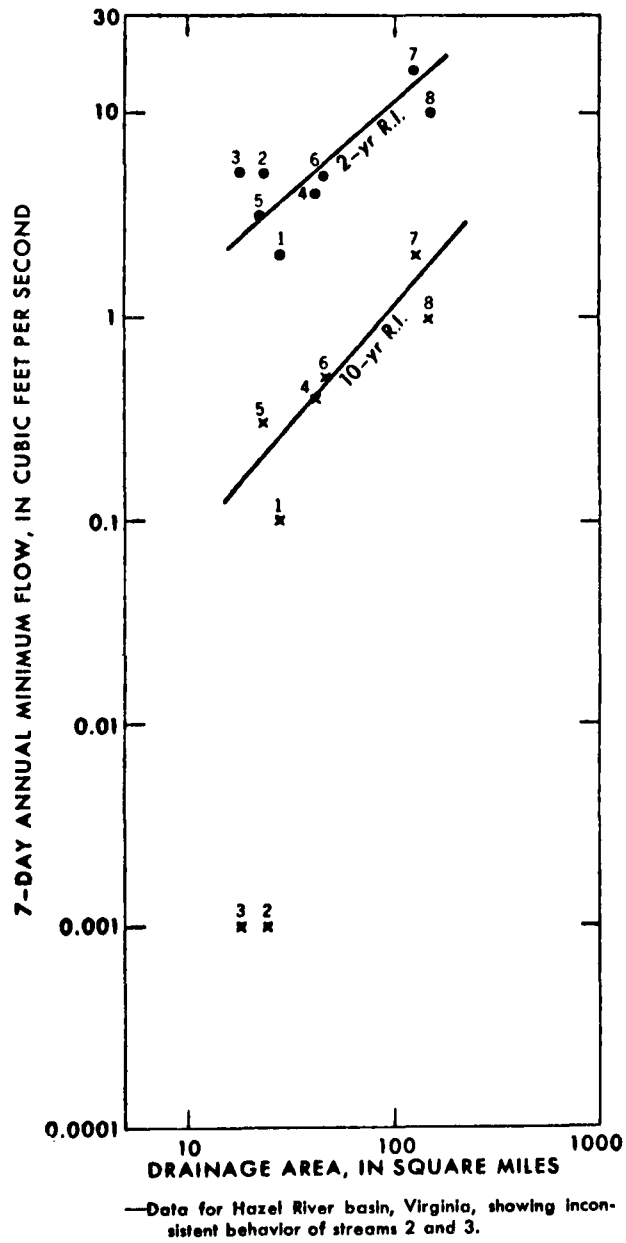


Figure 24.2 LOW FLOW FREQUENCY CURVES (Cont'd)

number of factors; the most important factor is that the flows are very dependent upon the geology and satisfactory analytical indexes of geologic characteristics are not available. Activities of man, which influence streamflow, are also greatly magnified during low flow periods and are difficult to account for. Diversions, changing vegetation such as harvesting crops, irrigation return flows, sewage flows, etc., greatly complicate the situation. The only reasonably successful applications have been for regions wherein all significant basin characteristics, except drainage area, have extremely limited range. For studies constrained by a small budget and short time, however, this technique may be the only reasonable alternative available.

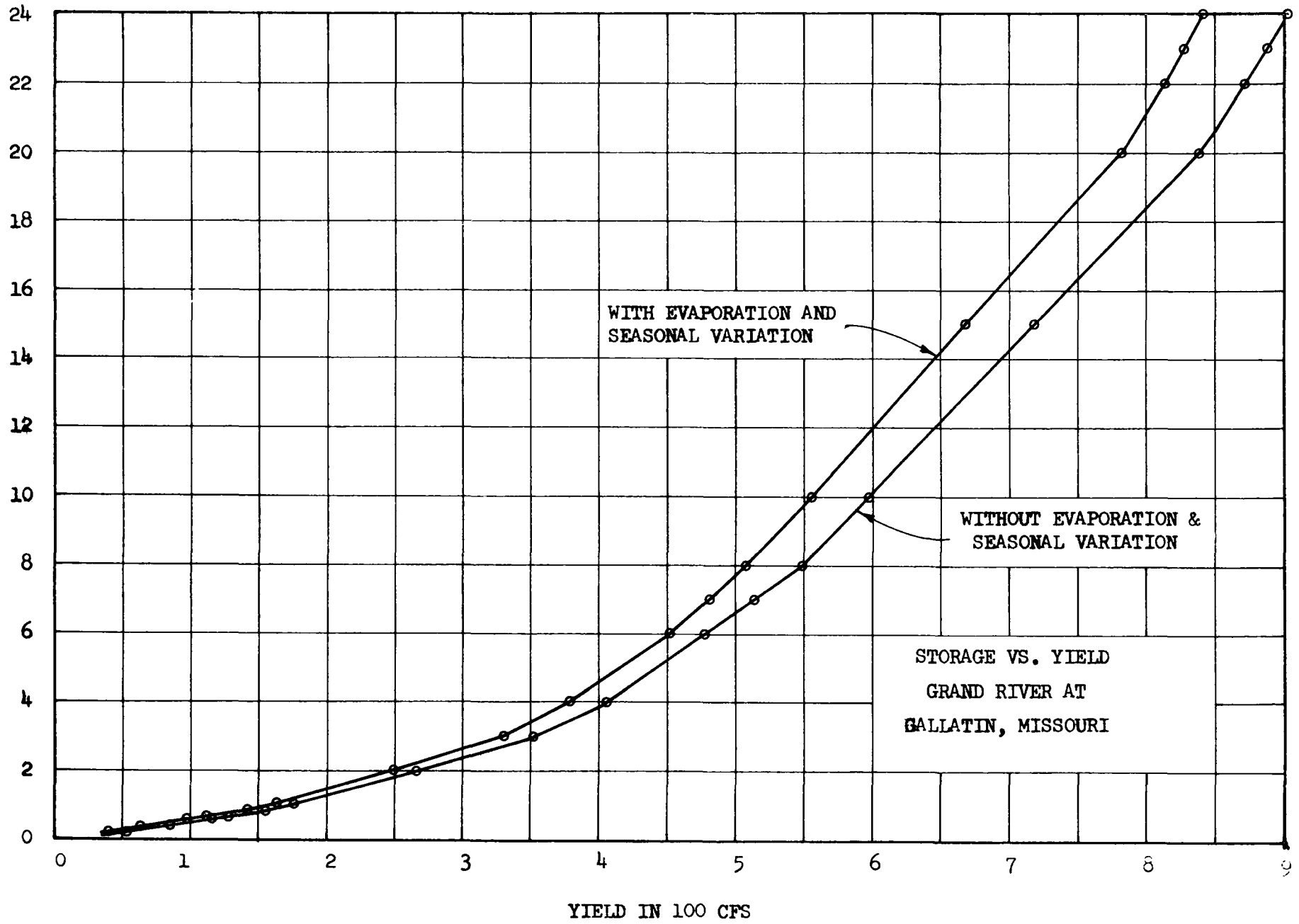
### Storage-yield Analysis

Storage-yield analysis is generally directed toward determining the "yield" (available water) which may be obtained, if a specified amount of storage is provided for a given streamflow sequence. Figure 24.3 is a sample storage yield function derived by simulation analysis. The methods range from nonsequential mass diagrams, sequential mass diagrams (The Rippl Method) to sequential routing of historic flows and application of synthetic hydrology concepts. Nonsequential and sequential mass diagram analysis are simplified methods that may be applicable for preliminary studies.

Nonsequential Mass Curves: A nonsequential mass diagram represents the cumulative volume that can be expected for a specific exceedance or nonexceedance frequency. It is constructed from a comprehensive series of low flow volume duration frequency curves that are developed by conventional analysis. This method does not consider the historical sequencing of historic flows.

The advantages of nonsequential mass analysis are:

- o It is relatively quick and simple
- o A range of risks of storages can easily be examined
- o The method recognizes that future streamflow will be different than the historic sequence.

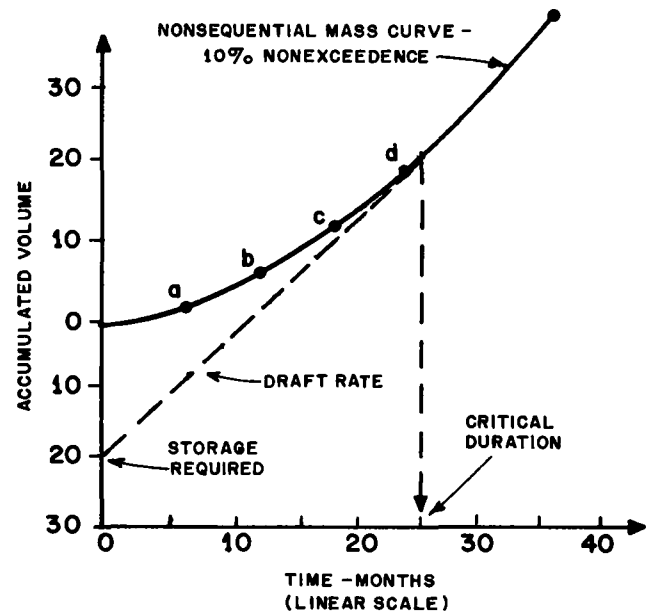
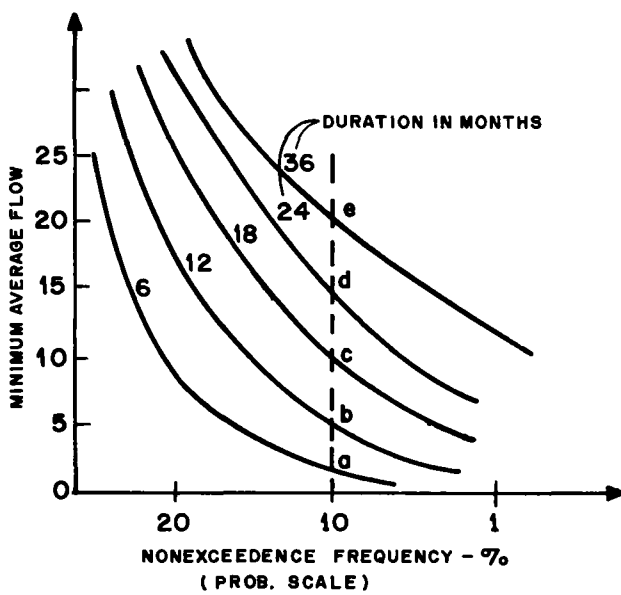


STORAGE IN 100,000 AC.-FT.

Figure 24.3

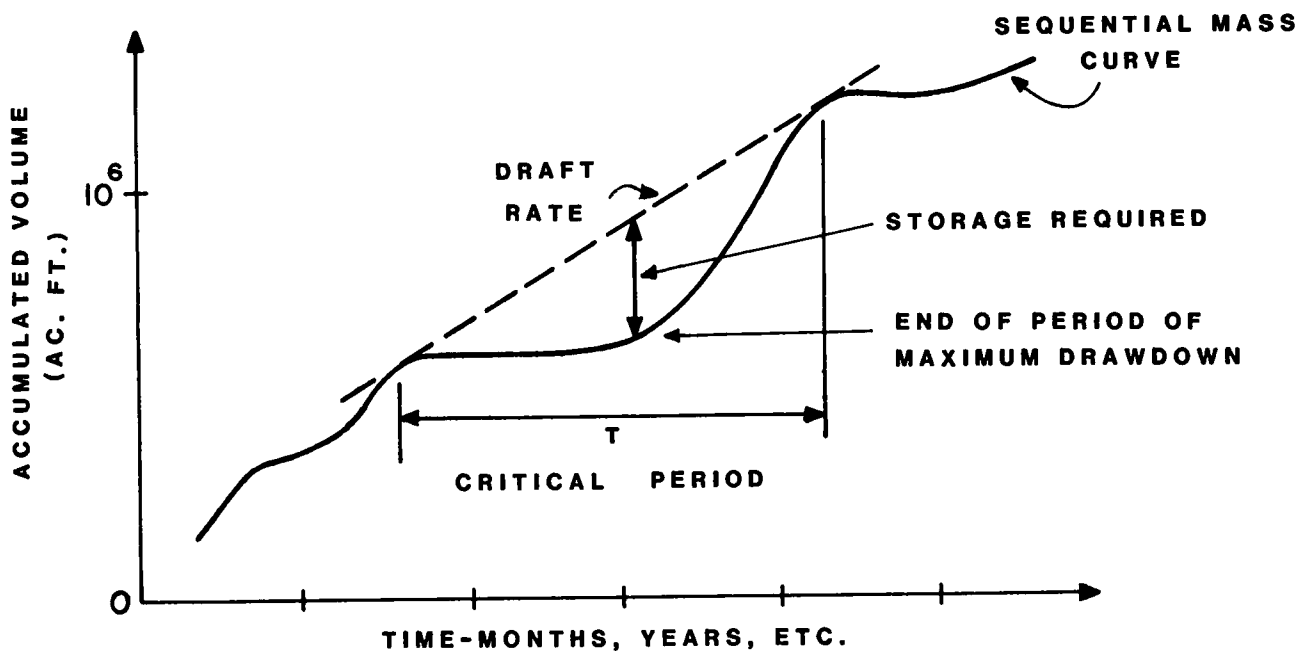
The main disadvantages of the technique are:

- o The assumption of nonsequential inflow may cause long-term persistence (drought) effects to be modeled incorrectly
- o The draft rate must be uniform
- o The technique cannot easily account for losses such as evaporation



Sequential Mass Curves: A sequential mass diagram (Rippl diagram) is constructed by plotting the accumulated flow volume versus time for the period-of-record. A constant draft rate-time line constructed tangent to the curve permits defining the storage required and the "critical" shortage period.





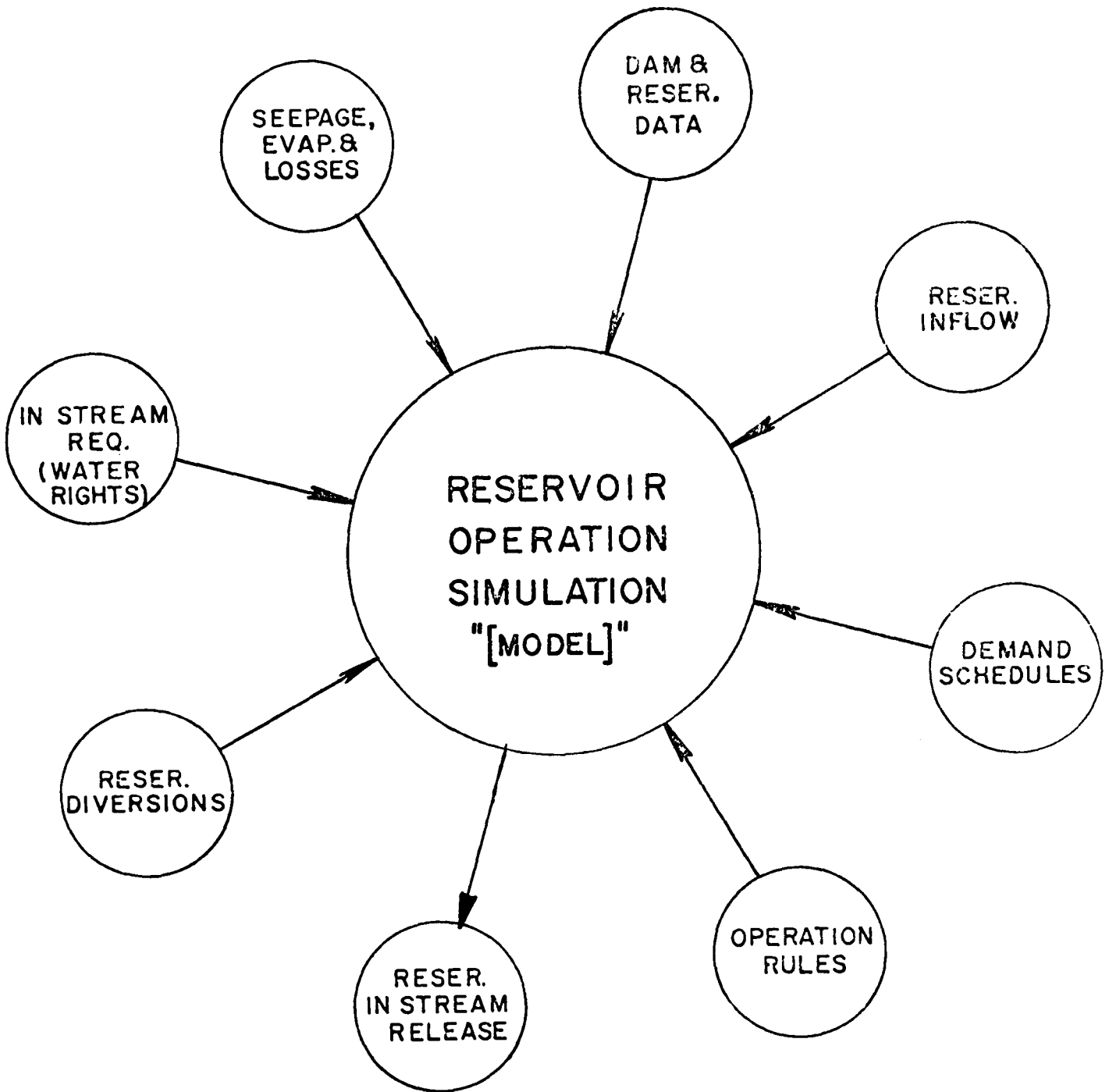
The advantages of the Rippl method are:

- o Simplicity
- o Ease in interpretation
- o Considers sequential nature of inflows and draft rates

Its main disadvantages are:

- o Promotes firm yield concept (no probabilities attached to shortages)
- o Difficult to account for losses such as evaporation

Sequential Routing: Sequential routing of streamflow involves routing a time series of streamflows through a hypothesized reservoir. This method is more detailed than the previous two procedures. As generally practiced, it is restricted to historic records. Seasonal variations in drafts, losses, storage allocations, etc., can easily be accommodated. A repetitive trial and error procedure is performed by selecting a reservoir size, routing flows, and examining the performance. This tedious procedure is repeated. The major events involved in performing sequential routing studies are illustrated in Figure 24.4, and include:



**Figure 24.4 SEQUENTIAL ROUTING STUDIES**

- o Reservoir inflow - Historic inflow must be corrected to a base condition of interest or a synthetic flow sequence must be generated. Routing in monthly time intervals is adequate except in hydropower investigations where 6-24 hour intervals are common.
- o Dam and reservoir data - Determine area capacity curve, outlet capacities, etc. This provides the basis for determining releases and evaporation losses.
- o Reservoir loss function - Determine potential evaporation loss (a major component when large storages are being investigated), seepage from reservoir, flow past dam, etc.
- o Downstream requirements - Develop minimum flow needs for water rights, etc., as separate from demand functions.
- o Develop demand schedules - Demand schedules are seasonal, vary by years, and consist of instream (for fish, water quality and recreation) and water supply diversions. Demands should definitely be considered a variable in the analysis.
- o Operation regulations - This involves predetermination of relative priorities when conflicts on demands occur, such as between instream and diversion uses and reservoir recreation requirements (pool level).
- o Reservoir diversion - The amount of water that can be diverted from the reservoir to supply a diversion demand is based on the results of the operation study. Diversion requirements are seasonal and can also vary by years.
- o Reservoir releases - The result of the operation study can be greater than, less than, or equal to the instream demand.

### Computer Applications

Sequential routing studies are extremely tedious by hand and fortunately are readily adaptable to computer modeling. HEC [10] and HEC [11] are complete general application computer programs available to perform reservoir yield studies. These programs can perform system operation studies which consider multipurpose demands and have the capacity to accommodate a range of operation criteria.

The user manuals for the above programs describe in detail the capabilities and limitations of the programs. Figure 24.4 is a schematic diagram of a typical reservoir operation simulation model.

### Evaluation of Results

Sequential routings with several levels of development and requirements quickly generate more results than can easily be assimilated. Therefore, criteria are defined that measure the performance of a large system. Some common criteria used to evaluate a complex system are:

- o Minimize the total system shortages - Each user has an equal priority.
- o Maximize the benefits - This concept allows the impact of a shortage to be expressed in financial terms but tends to crowd out lesser users
- o Shortage index function - The shortage index function is an empirical, nonlinear, function that causes the larger shortages to have a much greater impact, than the smaller shortages

$$\text{Shortage Index} = \frac{100}{\text{years}} \sum \left( \frac{\text{annual shortage}}{\text{annual demand}} \right)^2$$

General Comments: The exclusive use of historic streamflow to perform routings that determine reservoir yield, has been questioned. The use of sequential routings with historic record causes the project size and operating scheme to be based on the exact sequence of historic flows. If a worse drought occurs in the future the reservoir sized in this manner will not have sufficient storage. Another problem when using historical data in this manner, is that the size of a project is influenced by the length of record. The historic record is only one of an infinitely large group of equally likely streamflow sequences and the use of only the historic record will bias the results. It has been proposed that alternative sequences of equally likely future streamflows be generated by synthetic means using principles of stochastic analysis.

Stochastic Models: Extensive research over the past 10 years has developed a number of models capable of synthesizing alternative stream flow sequences. One problem with these models has been the reproduction of long-term droughts. While this approach has been used successfully in some parts of the country there are some instances when the model has not produced synthetic streamflow sequences with reasonable droughts.

Current Practice: Present procedures continue to rely almost exclusively upon use of historic streamflow records to perform routing studies. Practitioners have not become familiar enough with the stochastic models to recognize when they are not performing properly. In addition, the use of such models provides a range of storages with associated levels of risk rather than a single storage value. This additional information is more cumbersome to use in the planning process. If stochastic streamflows are to be employed in a study, they should be used with caution, and with the consultation of experts on the subject.

The information in Table 24.1 illustrates the general concept of use of stochastic streamflow records. The data summarizes the storage requirements for the yields indicated for alternative future inflows that were developed from a stochastic streamflow generation computer program.

An example of a major drought is illustrated in Figure 24.5, which shows the historic streamflows of the Red River. Note the severe drought of the 1930's. The HEC's stochastic model, HEC [12] was unable to duplicate a drought of such severity. This is a major reason why these models must be used with caution.

**Table 24.1**

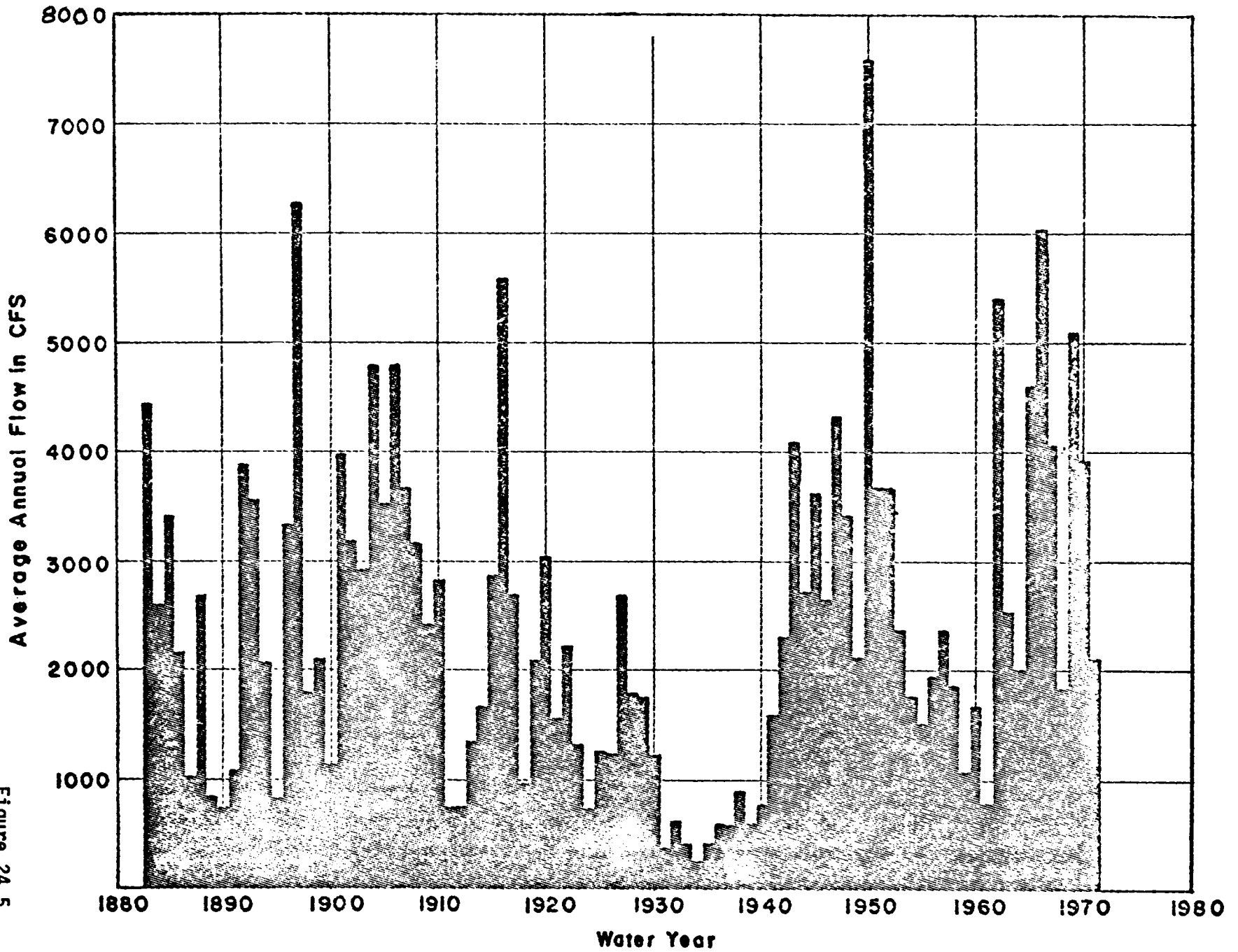
ARROYO SECO

STORAGE REQUIREMENTS

Starting Year	Storage Requirements in 1000 acre feet for yields of			
	30%	50%	70%	85%
1	36.2	84.0	175.4	518.3
51	40.0	181.9	303.3	426.4
101	43.0	111.7	234.6	481.6
151	25.5	95.3	232.4	399.0
201	34.1	126.9	228.2	598.6
251	49.0	140.3	380.9	634.3
301	41.8	122.3	259.5	471.4
351	22.7	79.7	253.1	683.3
401	26.9	132.8	291.8	793.4
451	37.8	132.2	210.1	486.9
Long Term	49.0	181.9	380.9	699.5

Source: Beard, L. R. and Kubik, H. E., Drought Severity and Water Supply Dependability, Technical Paper No. 30, The Hydrologic Engineering Center, Davis, CA., January 1972.

Figure 24.5



ANNUAL STREAMFLOW SEQUENCE

Red River of the North at Grand Forks, North Dakota

QUESTIONS  
CHAPTER 24  
RESERVOIR YIELD STUDIES

1. The evaluation of low flow conditions involve objectives of analysis different from those encountered in storm runoff. What types of planning investigations involve low flow analysis? What time intervals and flow components are usually of concern?
2. Define a non-exceedance frequency curve and a flow duration curve.



DISCUSSION OF QUESTIONS  
CHAPTER 24  
RESERVOIR YIELD STUDIES

1. Water resource planning studies that involve low flow analysis include water supply, low flow augmentation for recreation, fish and wildlife, hydropower and water quality. The time scale associated with low flow analysis is generally weeks or months as compared to storm analysis where days or less is usually appropriate. The components of the hydrologic system that are important in low flow analysis are evaporation, transpiration, channel infiltration and base flow conditions.
2. A non-exceedance frequency curve states the percent chance in a specific time period of flow not being exceeded. A duration curve states the percent of time, for the historic period-of-record, that flows will or will not be exceeded.

## CHAPTER 25

### CONCEPTS OF RESERVOIR SIZING AND OPERATION

#### Need for Reservoirs

Whatever the size of a reservoir or ultimate use of the water, the main function of a reservoir is to stabilize the flow of water by regulating a varying supply in a natural stream, to satisfy a varying demand in a natural stream, or to satisfy a varying demand by ultimate consumers. A water-supply, irrigation, or hydroelectric project drawing water directly from a stream may be unable to satisfy the demands of its consumers during extremely low flows. This stream, which may carry little or no water during portions of the year, often becomes extremely hazardous after heavy rains. A storage or conservation reservoir can retain such excess water from periods of high flow for use during periods of low flow or drought. In addition to conserving water for later use, the storage of flood water may reduce flood damage below the reservoir. Reservoirs may be built for single use purposes such as flood control or water supply for a municipality, or they may be designed and constructed for multiple purposes including water supply, recreation, flood control etc. Table 25.1 lists the purposes of reservoirs and alternatives that may be considered in lieu of constructing a reservoir.

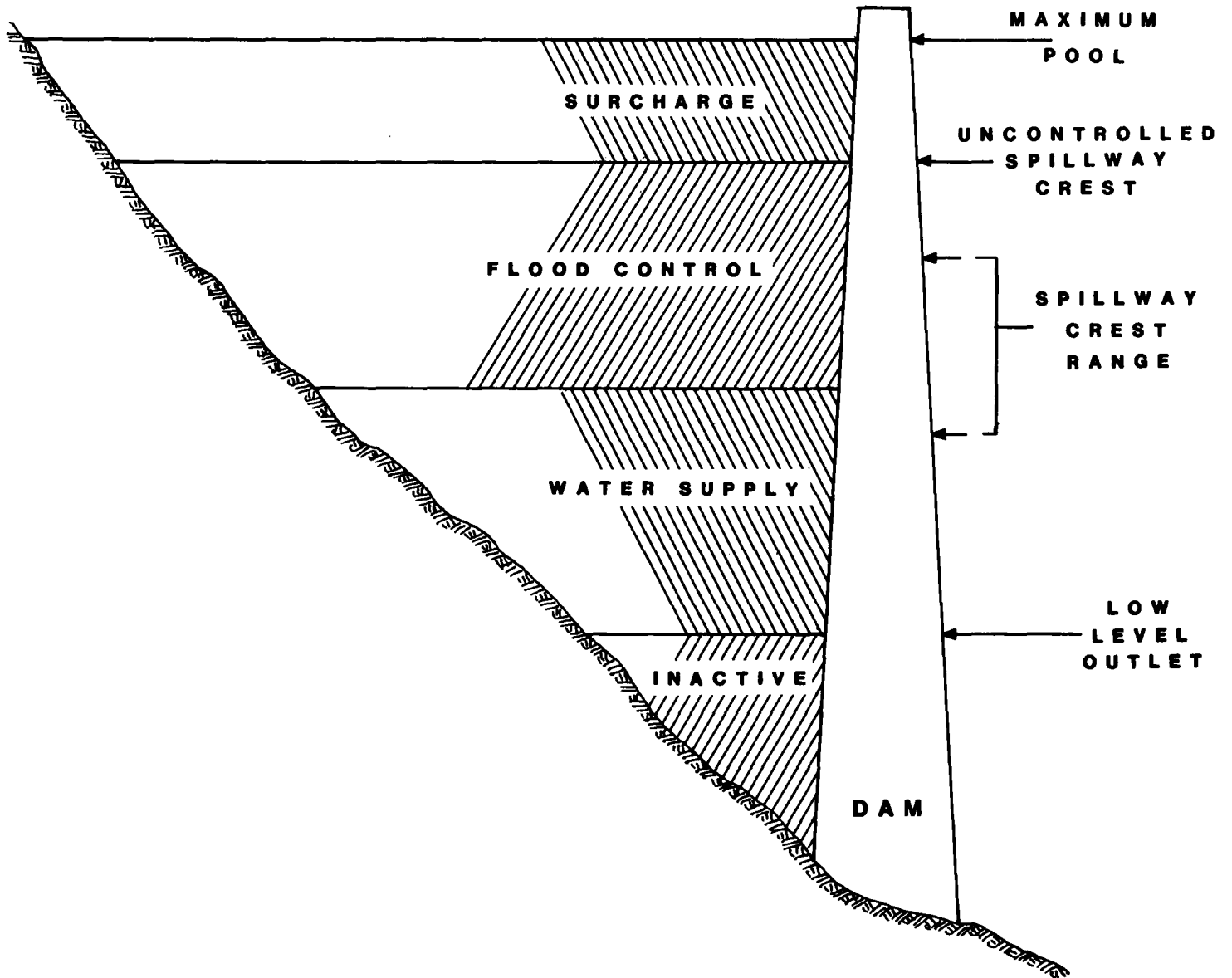
#### Reservoir Terminology

In order to understand the basic concepts involving the operation of a reservoir it is necessary to be familiar with the terminology. Table 25.2 shows various reservoir storage levels, and the corresponding pool elevations and purposes associated with each storage level. Figure 25.1 conceptually illustrates each storage level.

#### Reservoir Operation Requirements

Reservoir operation depends on the number and location of reservoirs in the system, the allocated storage capacities and pool levels used in justifying the reservoir system in the planning and design studies, and under certain conditions upon the flooding or low flow requirements of downstream locations. The reservoir system in a watershed may consist of a single

**RESERVOIR STORAGE LEVELS**



**Figure 25.1 RESERVOIR POOL AND STORAGE LEVELS**

Table 25.1

RESERVOIR PURPOSES AND ALTERNATIVES TO RESERVOIRS

<u>Reservoir Purposes</u>	<u>Alternatives to Reservoirs</u>
● Flood Control	<ol style="list-style-type: none"> <li>1. Zoning, floodproofing or relocation</li> <li>2. Small detention storage systems</li> <li>3. Channel improvements or diversions</li> <li>4. Levees or flood walls</li> <li>5. Land treatment</li> <li>6. Combinations of above</li> </ol>
● Hydropower	<ol style="list-style-type: none"> <li>1. Nuclear</li> <li>2. Thermal</li> <li>3. Solar</li> <li>4. Geothermal</li> <li>5. Biomass</li> <li>6. Cogeneration</li> <li>7. Wind power</li> <li>8. Tidal</li> <li>9. Energy conservation</li> </ol>
● Water Supply	<ol style="list-style-type: none"> <li>1. Ground water</li> <li>2. Long distance diversions</li> <li>3. Reuse</li> <li>4. Desalinization</li> <li>5. Cloud seeding</li> <li>6. Water conservation</li> </ol>
● Water Quality	<ol style="list-style-type: none"> <li>1. Waste water treatment</li> <li>2. Land or non-stream waste disposal</li> </ol>
● Recreation, Fish and Wildlife	<ol style="list-style-type: none"> <li>1. Preservation of "Wild or Scenic Rivers" in natural state.</li> </ol>
● Navigation	<ol style="list-style-type: none"> <li>1. Alternative transportation modes</li> <li>2. Dredging</li> </ol>
● Debris Barrier (sediment, trash)	<ol style="list-style-type: none"> <li>1. On-site land management</li> </ol>

reservoir, reservoirs in parallel, reservoirs in tandem (series), or in a complex system any number of combinations of the latter. Figure 25.2 illustrates possible reservoirs and control points in a system.

TABLE 25.2  
RESERVOIR STORAGE LEVELS

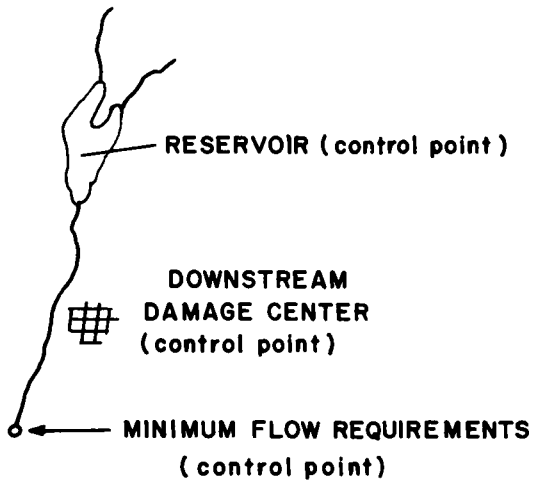
<u>Storage Zone</u>	<u>Pool Elevations</u>	<u>Purpose</u>
Inactive	Streambed to top of inactive pool	Power head, recreation, sediment reserve, reservoir fishery
Water Supply*	Top of inactive to top of water supply pool	Municipal and industrial, irrigation, hydropower, etc.
Flood Control*	Top of water supply to top of flood control pool	Flood Control storage
Surcharge	Maximum pool to top of flood control pool	Reduce spillway size for spillway design flood

\*The distribution of storage between flood control and water supply levels often varies seasonally.

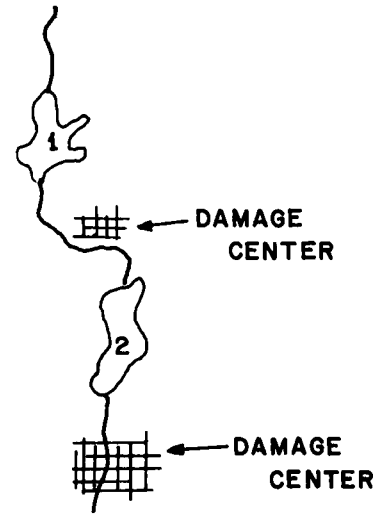
Individual Reservoirs: The operation of a single reservoir in a system consists of:

- o Maintaining downstream low flows authorized for water supply, irrigation, water quality, etc. If hydropower is authorized, flows to maintain power demands are also required.
- o Releasing excess water above conservation pool (water in flood control pool) unless flooding occurs at one or more downstream control points (damage centers). Maintaining downstream channel capacity after the project is completed is a major problem in reservoir regulation.

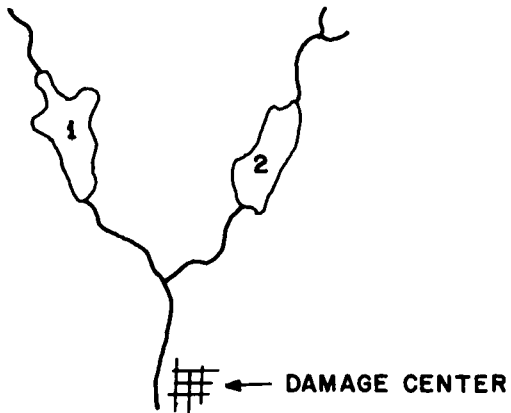
**SINGLE RESERVOIR**



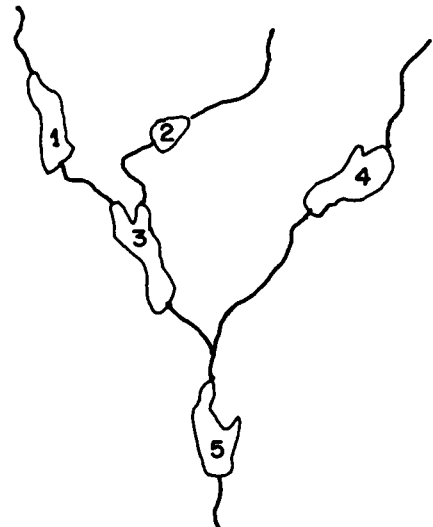
**TANDEM RESERVOIRS**



**RESERVOIRS IN PARALLEL**



**COMPLEX SYSTEM**



**SYSTEM CONTROL POINTS**

- o FLOOD CONTROL - Reservoirs  
- Damage Centers
- o WATER SUPPLY STUDIES - Reservoirs  
- Minimum Flow Requirement Locations

**Figure 25.2 RESERVOIR SYSTEMS AND CONTROL POINTS**

- o Releasing water stored in the flood control pool as quickly as possible without causing downstream flooding. These releases must consider forecasting abilities (or inabilities) as well as the constraints or release rate of change where severe increases or decreases in flow rates may cause bank caving, etc.
- o Opening floodgates when the top of the induced surcharge pool is reached.

Parallel Reservoirs: After meeting the requirements of individual reservoirs, the operation of parallel reservoirs requires keeping the reservoirs in balance (usually the percent of storage full) by releasing flows from the reservoir in the greatest danger first.

Tandem Reservoirs: Tandem reservoirs are usually operated by keeping the upstream reservoir in balance with downstream reservoirs, if possible, after observing individual reservoir constraints.

#### Hydrologic Design Studies Required for Reservoirs

The hydrologic design of a reservoir should be made using the following procedure:

- o Determine drainage area runoff characteristics (quantity, variability and seasonal nature)
  - Area capacity curves
  - Channel capacities
  - Evaporation losses
  - Channel losses
  - Etc.
- o Determine demands on system (yields, power loads, etc.)
  - Low flows
  - Diversions
  - Water rights

- o Determine storage requirements
  - Sediment reserves
  - Minimums of power head, recreation and fish and wildlife
  - Active conservation storage for power, water supply, irrigation, water quality, etc.
  - Flood Control
  - Induced surcharge storage
- o Determine possible top of dam heights
  - Develop spillway design flood, tailwater rating curves
  - Develop spillway rating curves for various structures
  - Determine maximum pool capacity by routings of the Standard Project Flood
  - Determine freeboard, including wave run up
- o Determine hydraulic profiles for structures (spillway, stilling basin, conduit, etc.)
- o Develop discharge frequency curves with and without project
- o Develop reservoir storage frequency and duration curves
- o Complete maximum rate of drawdown and evacuation time study

### Criteria for Hydrologic Reservoir Studies

The usual design criteria for a reservoir is:

- o Use 100-years accumulation of sediment
- o Design water yield (including power) for maximum drought of record
- o Design flood control storage for 50-year to Standard Project Flood capacity.
- o Design uncontrolled spillway with crest at top of flood control pool or controlled spillway with the top of gates at the top of flood control pool
- o Size the outlet conduit to pass channel capacity at the top of conservation pool or to evacuate the reservoir in the required time during emergency
- o Use the Probable Maximum Flood to design the spillway of large dams
- o Select the spillway that results in the minimum total cost for the project
- o Use a 5-foot freeboard design for large dams



QUESTIONS  
CHAPTER 25  
CONCEPTS OF RESERVOIR SIZING AND OPERATION

1. Why does the storage distribution allocated between flood control and water supply needs in a reservoir often vary by seasons?
2. Why is the Probable Maximum Flood used in the spillway design of major Corps reservoirs when smaller design floods are more economically feasible?
3. Describe the purpose of the inactive, water supply, flood control, and surcharge pools of a reservoir.
4. What are the basic parameters that affect the operation of a reservoir?

DISCUSSION OF QUESTIONS  
CHAPTER 25  
CONCEPTS OF RESERVOIR SIZING AND OPERATION

1. The risk of flooding and water supply requirements often vary seasonally making the allocation of storage levels which vary accordingly a practical operation procedure.
2. The Probable Maximum Flood is used in the spillway design of major reservoirs to significantly reduce the chances of failure which could result in catastrophic loss of life, property and environment.
3. The inactive pool is often below the lowest outlet of the reservoir and may be used for power head, recreation, sediment reserve, and reservoir fisheries. The water supply pool is used for low flow augmentation, recreation, irrigation, etc. The flood control zone is used for flood control storage. The surcharge zone is designed to reduce the size of the spillway for passing safely the design flood.
4. Reservoir operation depends on the number and location of reservoirs in the system, and the allocated storage capacities and pool levels used in justifying the reservoir in planning and design studies.

MANAGING HYDROLOGIC STUDIES

CHAPTER 26  
HYDROLOGIC ASPECTS OF PLANNING STUDIES

Introduction

The objective of this chapter is to relate the various types and details of hydrologic studies that have been discussed to specific functional planning studies that may be of interest in any particular investigation. The discussion will relate facilities, hydrologic studies, and planning objectives in a general structure. The description will cover the following functional planning areas:

- o Flood control and conservation reservoirs
- o Flood channels and levees
- o Stream navigation
- o Interior drainage
- o Storm water management
- o Flood insurance and flood plain management
- o Nonstructural flood control measures

The broad hydrologic analysis categories that will be related to these functional planning areas will be hydrograph analysis, fluvial hydraulics, frequency analysis, and sequential operation (period-of-record type analysis).

Observed Data

Because of the dominant significance of observed data in relation to all hydrologic analysis methodologies, a short discussion on important facets will provide background for the subsequent functional area discussion. Observed data is the foundation for most hydrologic analysis. The science of hydrologic engineering is not sufficiently advanced that computations and conclusions can be made without concurrence as to reliability that may be shown by comparing computed values with observed information. The profession has not constructed sufficiently general analysis methods and models so that adjustments and calibrations are not required. Observed data is the only present means to determine and verify the reliability of hydrologic analyses.

Most hydrologic studies that develop confidence in the users of the information require as a minimum, somewhere within the region, a long-term record of gaged flow data that can be used as a frequency index location. In addition, observations of specific events that can be correlated with existing watershed conditions so that computational methodologies can be verified are normally needed at selected locations.

The most reliable and valuable data is streamflow at selected locations because of its measurement accuracy (when related to other data) and its characteristic of integrating the effect of conditions above the measurement location. Continuous streamflow data is, therefore, invaluable for planning studies. Precipitation data is much less reliable because of areal variation. For detailed studies of specific small, highly heterogeneous areas, (especially urban storm water studies) dense networks of precipitation data may be necessary.

Other observed data may include water quality data for short time intervals, (for storm water quality studies) and high water marks of specific events for calibration of fluvial hydraulic studies. Suspended sediment for determination of computational coefficients for sediment transport is becoming more important as greater portions of our river systems are subjected to control. As studies focus more on urban areas where dynamic watershed changes are occurring, it is important to define the watershed conditions (say in terms of land use) at intervals so that the observed data may be generalized.

### Reservoirs

Reservoirs are designed to store and redistribute (in time) the volume of water available for purposes for which the water is intended for use. Reservoirs by their nature can serve many purposes, some of which may complement or conflict with each other, such as the desire to release water for flood control but also store it for conservation purposes. As a consequence, reservoirs receive considerable detailed hydrologic analysis to determine appropriate storage sizes and to forecast their performance for conditions of interest.

Major storage reservoirs, because of diminishing availability of attractive reservoir sites, have usually been studied a number of times in the past so that historic gaged data is normally available. As a consequence, the study of reservoirs generally places quite heavy reliance upon use of the historic record for conclusions.

Discussions of reservoirs will be divided into those studies related to the structure itself (the dam) and discussions related to the general functional purposes of reservoirs.

Structure Safety - A great deal of hydrologic study is involved in determination of design features of dams so that they will be safe from structural failure which could result in catastrophic destruction of downstream areas. The features that undergo considerable scrutiny in relation to safety are the design of the spillway (and associated gated facilities), the determination of the top of the dam, and the associated emergency operating rules for preserving the integrity of the structure during extreme events. The major studies that develop hydrologic information pertinent to these areas of interest are within the hydrograph analysis' category. The desire is generally to synthesize a very large and rare event such that design studies can proceed to assure safety. Very large and rare events generally require synthetic methods where general computational criteria is prepared that is developed from study of large storms on a regional basis. The studies involve synthesizing the storm itself, calibration of the analysis process based on historic data, and computation of the volumes and rates of flow for the large events. Storm synthesis involves determining storm precipitation and construction of intensity sequences based upon general criteria. These large events (hydrographs) are then processed through a routing analysis for the reservoirs.

The freeboard requirement and thus the top of the dam is determined by routing the large flood for alternative assumptions of operating policies and spillway sizes. The top of the dam and spillway are generally sized in a joint analysis since there are cost economies that can be incurred by storing more water behind a higher dam to reduce the spillway costs. Spillways are quite expensive hydraulic structures.

Final studies related to the safety of the dam are required to develop operating rules so that the safety of the dam will not be jeopardized during passage of the spillway design flood event. It is not generally well known by persons other than those who specialize in hydrologic studies for reservoirs, but reservoirs, by occupying valley storage that existed naturally, result in peak flows within the reservoir higher than would have occurred in the absence of the reservoir. This occurs primarily because flood hydrographs travel significantly faster through a deep reservoir than through natural channels resulting in flows concentrating more rapidly which cause higher peak flow rates. In addition, rain falling directly upon the reservoir surface contributes to higher peak flows. The operating rules for gated structures are therefore designed to allow full release capacity of the reservoir's outlet works to be utilized while not releasing flow in excess of that which would have occurred in the absence of the reservoir and thus not cause a worse downstream condition than would have occurred historically.

Reservoir Flood Control - This discussion is simplified since the Corps has spent the past 40 years devising complicated hydrologic studies to be used for analysis of individual flood control reservoirs and systems of flood control reservoirs. This discussion will deal with the functional studies in a conceptual sense, as if for a single reservoir.

The hydrograph analysis associated with the flood control function of a reservoir (not its safety) involves development of major floods of record (or synthetic floods if the record seems inadequate) for processing by routing studies to determine the performance of the reservoir in reducing flow rates downstream. In addition, hydrograph analysis studies for virtually all major reservoirs require development of the standard project flood (a major flood event that has a reasonable chance of occurring within the lifetime of the structure) to determine its operation performance, whether or not the reservoir is designed to control this event. The performance of the reservoir is generally determined for with and without conditions by estimating peak flow rates at control points of interest downstream by application of reservoir routing methods, downstream channel routing, and hydrograph computation procedures.

The frequency analysis associated with the flood control function of a reservoir (the flow frequency analysis at control points for which reservoirs operate will be discussed later) requires the determination of the frequency of pool filling. This information can be used to size the reservoir storage pool and to determine the real estate requirements for the reservoir pool. It is also necessary to assign, if possible, exceedance frequencies to the events that are routed through the reservoirs in order to determine the performance in the immediate vicinity of the reservoir. It may be necessary, if synthetic floods are used instead of all major historical floods, to perform volume-duration-frequency analysis to determine the critical storage periods. By doing so, it will be known which sequences of hydrologic events may be more critical than isolated major hydrologic events.

Sequential operational studies are most important in the analysis of reservoir systems in which there is a significant amount of storage in relation to the runoff volume of the watershed. For instance, a rapid sequence of moderate storm events could be considerably more critical than a single large event in a system comprising many storage reservoirs. It should also be noted that some hydrologists in the Corps believe that the only reliable method of determining the performance of a flood control reservoir is by sequential operation of period-of-record analysis to determine the performance of the reservoir for a period equal to that has been recorded. Sequential operational studies for period-of-record analysis require that considerable attention be devoted to the development of a complete basin-wide system of historical data which would comprise a major portion of analysis of a flood reservoir if studied using this philosophy.

Flood Control Hydrologic Analysis at Control Points: The hydrologic analysis required at control points (may be called 'damage centers'), which are those locations for which flood protection is being provided, is needed to determine the flood hazard. The flood hazard is defined as the magnitude and frequency of flooding for the with and without conditions. The hydrograph analysis associated with control points is generally that required for determination of the flow rates for a range of hydrologic events so that frequency analysis can be performed. These may require rainfall-runoff analyses for areas intervening between reservoirs and the control points, or



routing of historic observed flows from controlled locations and tributaries to control points of interest.

Fluvial hydraulics is an important analysis component that relates flow rates to water surface elevations. Subsequently, this information can be directly related to flood damage potential. It is important to realize that the hydrologist views flood hazard in terms of flow rate, and from fluvial hydraulics associates elevation with flow frequency. In contrast, the economist typically is more directly concerned with the stage-frequency relationship. The reason the hydrologist makes the conceptual separation is that flow-frequency analysis is more reliable than stage-frequency analysis, and in addition the affects of changes in stream hydraulics (such as geometry changes) can be directly included in the analysis. The economist keys on stage because it is the hydrologic parameter most directly related to damage.

The frequency analysis associated with control points for flood control is that required to develop exceedance frequency curves for the with and without flow conditions that will subsequently be converted to stage for the economic analysis. Exceedance frequency curves of damage using flood duration as well as peak discharge may be necessary if the damage potential at control points are significantly affected by the time associated with high floods, such as from inundation of agricultural crops and closing of major roadways.

Reservoir Yield Analysis: Reservoir water supply purposes include the functional areas of water supply for both municipal and industrial purposes, hydro-electric power generation, low-flow augmentation for fish and wildlife enhancement, water quality improvement, and navigation. The objective of the hydrologic analysis is to forecast the availability of water and the schedule of releases that will allow the conservation purposes to be best served. The release requirements for conservation purposes are not at all complimentary. The operation usually entails withholding flows in storage during high-flow periods and releasing flows from storage during low-flow periods to provide water at times when inadequate natural flow exists. The predominant hydrologic analysis methodology used for reservoir yield studies is that of sequential operations.

An important task of sequential operational studies is the development of period-of-record flows (long time period continuous hydrologic flow data at all storage locations and control points of interest for as many years of record as possible). The flow data that are usually developed are weekly or monthly flow volumes.

The objective of the operation study is to process by sequential simulation the period-of-record flows and determine the storage required to provide the yield (conservation volume output) that would be needed to supply varying demand schedules from alternative configurations of facilities containing conservation storage. A phrase that is associated almost exclusively with conservation analysis is that of "the critical period" which when associated with the analysis of a continuous record, is the time period in which the reservoir is drawdown from full to empty and refills. The yield associated with this period is usually termed "firm yield", and is the amount of water that can be supplied continuously throughout the critical period.

The frequency analysis associated with conservation studies is that required to assign exceedance frequencies to yield or low flows in streams. The frequency analysis for low flows is much less developed theoretically than for flood flows because the assumptions associated with frequently used probability distributions are much less applicable to low-flow events. In addition, multi-year analysis caused by carry-over storage requires special interpretation. There has been increasing attention paid to the uncertainty involved in observed records recognizing that it is but a single trace of an infinite number of alternative future sequences of flows. In recognition of this, analysis to generate synthetic alternative sequences of future flows is being performed in some instances. Such an analysis can provide information for assigning exceedance frequencies to the shortages that would occur under alternative operating policies and the amounts and distributions of conservation storage.

Recreation: Reservoirs are used extensively for recreation nationwide. Historically, reservoirs were designed to serve the functional purposes of flood control and conservation while only incidental benefits to recreation

occurred. With an increase in leisure time and more attention focused on recreation values in recent years, considerably more hydrologic data is processed specifically to develop information for recreation purposes. The type of information of interest to recreation planners can generally be extracted from other more functional oriented analysis, but it does require repackaging data. For example, recreation studies usually need information on the fluctuation of the pool levels and the rate of pool drawdown, both of which can be determined from sequential reservoir routing studies.

### Flood Channels and Levees

Levees and channels are designed to either confine the flow and thus exclude it from areas of potential flood damage, or reduce the stage for specific flow events so that the damage potential for major events is lessened. The objective of the hydrologic analysis is to determine the flow and stage for hydrologic events of interest with and without the channel and levee proposals and to assess any systematic change in hydrologic response of the watersheds that may result from construction of channel and levee works. Substantial reliance is usually placed upon historic records if they are available, but with increased urban development occurring, and projects becoming smaller in scale, fewer long term historic records are available for project studies.

Hydrograph analysis associated with channel and levee studies is required for development of synthetic events (hydrographs) to determine the distribution of flow rates throughout the reaches of interest, (for design purposes) and to assess the flow rates downstream resulting from any changes in the system hydrologic response. Synthetic hydrologic event calculations are necessary when sufficient historic data is not available. In recent years, considerably more attention has been placed upon evaluating the hydrologic effect of altering watershed conveyance facilities such as by extensive channel enlargement or levees. The technical analysis required to determine this is a combination of hydrograph analysis computations and storage routing procedures. The hydrograph computations are required to determine hydrographs at the locations where modifications will occur and then storage routing procedures are used to route those hydrographs through the reaches using information developed in fluvial hydraulic analysis.

Fluvial hydraulic analysis associated with channels and levees is required for determining the distribution of water surface elevation conditions that might occur in the future. A significant proportion of fluvial hydraulic analysis can be involved in determining the storage volumes within the reaches needed for routing studies to determine the hydrologic changes that may result from the project. This latter analysis is necessary only when there are extensive modifications proposed for a significant portion of the conveyance system of the basin.

Sediment transport computations are becoming more important and are being performed more frequently as planners and designers recognize that analysis based on rigid boundary hydraulics can provide a poor estimate of water surface elevations for future time periods when a changed sediment regime might exist. Fluvial hydraulic analysis is the technical design discipline responsible for determining the size of channels and determining the heights of levees.

Frequency analysis associated with channels and levees is required to determine the exceedance frequency of flows (and stages) with and without the proposals for correlation with economic and other studies. It is at times important to determine the exceedance frequencies of damages associated with extended durations of flows for damage analysis.

### Stream Navigation

The objective of hydrologic studies associated with stream navigation is to determine the flow rate and physical geometry required to maintain navigation depths generally for low flow periods. The reservoir studies associated with navigation are the conservation studies described previously. Lock structures are depth control devices containing little storage so that the analysis associated with stream navigation (within the stream reaches themselves) predominantly involves fluvial hydraulics.

The hydrograph analysis associated with stream navigation is generally minor and is required to determine the flow rates along the study reaches to synthesize major events for determination of lock operation, and the

development of the type of flow duration data required for mobile boundary sediment transport computations. Fluvial hydraulics dominates stream navigation analysis and is required to determine the size and operating characteristics of navigation structures, the distribution and navigable depths throughout the reaches and the dredging requirements to keep the system in operation. Frequency analysis generally plays a minor role in navigation studies.

### Interior Drainage

Interior drainage is a label that has been associated with the facilities and management measures concerned with blocked drainage areas or areas behind levees adjacent to major streams. The areas that receive interior drainage type analysis are generally small, they frequently are already developed or are rapidly undergoing urban development, and invariably are extremely complex in terms of analysis required to determine adequate performance and requirements. Although the scale is small and generally the facilities required are modest, the analysis is quite complex normally requiring system studies for a variety of components and for many control points of interest. It is not uncommon for interior drainage facilities to include within a geographic area on the order of tens of square miles, a mixture of channel work, levees, detention storage, pumping facilities, gravity drain facilities and nonstructural measures.

Hydrograph analysis associated with interior drainage is directed towards development of a range of hydrograph events that must be synthesized because historic information is not available. The synthetic hydrograph events are routed and processed through the physical system which will include alternatives of detention storage and channel improvements within the framework of changing land use so that generalized hydrologic criteria will be necessary. Historic records, if available, will be available only for the main streams which are blocking drainage. The routing studies associated with interior drainage are complex because storage and pumping facilities can have external operating rules that cause the analysis to be interrupted as conditions change.

Frequency analysis is directed toward development of flow frequencies curves for the control points, which normally occur in most flood control studies, and also for the pools and ponding areas for rights-of-way acquisition and damages associated with ponding levels. In addition, it may be necessary to provide frequency information for the main stream opposite (or outside) levees or blocked areas so that joint frequency analysis (termed by hydrologists coincidental frequencies) can be prepared. This is at times necessary to determine the operation of pumping and gravity facilities for any possible combinations of high and low flows occurring between interior damage areas and the main stream. Volume-duration studies are generally not of major concern.

Sequential operations studies become important if there is considerable interaction between gravity facility operations (which might result if flow is blocked by high tailwater conditions) and pumping plant capacity. Sequential analysis is not always necessary because if the interaction does not cause differences in facility sizes and performance, even though it causes differences in operation, those details can be worked out during operation studies rather than planning studies. If the interaction is important, the general procedure is to synthesize a long period of streamflow by very simple analysis, using perhaps only precipitation as the input, determine the sequential operation of pumping facilities, detention storage and gravity drains, and assign frequencies to pool levels and pumping rates by conventional analysis.

Fluvial hydraulics can be a major portion of interior drainage studies because many interior control points require flow elevation data. In addition, a significant amount of design of open channel conveyance facilities (and some closed conduit systems) is usually required. Interior drainage, and to a similar extent stormwater management discussed below, is probably the most complicated hydrologic system requiring the full range of analysis of hydrologic tools without the benefit of historic records upon which to base the analysis and conclusions.

## Stormwater Management

Stormwater management refers to the analysis of measures required to remove excess stormwater from generally urban facilities. In recent years, with recognition that urban stormwater is a substantial contributor to water quality problems, increased attention has been focused on quality of urban stormwater and the requirements for possible treatment. Stormwater management analysis, in contrast to interior drainage, is generally concerned with the specific layout and configuration of the drainage system, since it can frequently be considerably different than the overlying topographic system. It is not uncommon for stormwater facilities to cross drainage boundaries.

The water quality information of interest is also very spatially specific and of concern in terms of pollutant washoff for specific events and sequence of events. Because treatment is quite expensive in relation to other types of water management, and cost is highly dependent upon the needed rate of treatment, storage is badly needed to reduce overall costs. As discussed previously, as the amount of storage in a system in relation to the runoff volume increases, the relative importance of sequential analysis increases. Consequently, urban stormwater studies associated with quality are generally dominated by sequential analysis whereas the quantity is generally associated with specific events for sizing conveyance facilities and determining the amount of pollution washoff.

Hydrograph analysis for stormwater management studies is basically similar to that required for interior drainage except that the specific configuration and distribution of collection and transportation facilities is of importance. The period-of-record is generally short and synthetic procedures using rainfall and rainfall/runoff models are required. Analysis associated with sizing and routing flows through detention storage can predominate.

The frequency analysis is quite similar to interior drainage with less need for coincident analysis for blocked drainage.

Sequential analysis predominates with the objective of storage-treatment studies being to determine least cost combinations for meeting specific target overflows (quantity and quality) over a period of historic record. The sequential analysis is usually quite simple in that the input is precipitation with the focus upon the sequential nature of process.

Fluvial hydraulics is dominated by analysis of prismatic channel conditions and man-made works. In some analysis methods the hydrograph analysis is performed by computing flows over planar surfaces (rather than unit hydrograph concepts), in effect converting the runoff analysis to a hydraulic analysis procedure.

### Flood Insurance

The hydrologic studies associated with flood insurance are, in a conceptual sense, identical to those required for any flood control evaluation of existing conditions at control points of interest. A description of this hydrologic analysis can be found in the Reservoir Section. The focus of flood insurance studies is upon existing watershed conditions and the definition of the lateral extent of flood insurance zones. The lateral and elevation description of computed flood events are adjusted to correspond to easily identified cultural features. Many consider the quality of flood insurance studies to approximate that of the Corps survey studies. In some instances, Corps districts maintain a higher level of detail for flood insurance studies which is equivalent in quality to design level studies.

### Nonstructural Flood Control Measures

The hydrologic analysis associated with nonstructural flood control measures is similar to that described for flood insurance. In addition to examining existing conditions, these studies require analysis of alternative future conditions as well. An additional requirement is a higher level of detail at a micro (very fine level of detail) scale. Experience to date indicates that the attractiveness of a variety of nonstructural measures which includes property acquisition, floodproofing, and zoning controls is



quite sensitive to the magnitude and exceedance frequency of flood events. Because of the heterogeneous nature of flood plain development, it appears that plan formulation must be site-specific for structures or at least tailored for structure categories. Perhaps as more experience is gained in the determination of the types and scale of nonstructural flood management measures appropriate for different hydrologic regimes, less micro scale detail will be necessary. Presently this does not seem to be the case.

### Summary

The hydrologic analyses associated with the range of planning studies generally involved in the Corps mission, include each of the broad types that have been discussed throughout this manual and within this chapter. The appropriate type of hydrologic study depends upon the relative emphasis of the planning purpose of concern alternative futures, and the amount and availability of historic data. As a general rule, the larger the stream system, the more emphasis on historic data and system operation modeling and the less on synthetic hydrology. The detail and scope of hydrologic studies is very much dependent upon the detail desired from hydrologic study output and the relative changes that are expected to occur in the hydrologic response of the system under alternative future conditions. Experience to date in hydrologic studies provides some guide as to the appropriate detail, but the technology to facilitate studies in urban areas is in the developmental stage and the planning information requirements are likewise not well known so that the loop is at present incomplete. The planner does not know what he wants, "exactly", and the hydrologist does not know what he can provide, "exactly." Patience and goodwill on the part of both, and the desire to meet joint objectives will be necessary for hydrologic studies related to planning in the foreseeable future.

Table 26.1 schematically displays the substance of this chapter.

Table 26.1

HYDROLOGIC ASPECTS OF PLANNING STUDIES  
(Planning Function/Hydrology Study) <sup>1/</sup>

	<u>Hydrograph Anal.</u>			<u>Frequency</u>			<u>Fluvial Hydr.</u>				<u>Sequential</u>	
	A	B	C <u>2/</u> <u>3/</u>	D	E	F	G	H	I	J	K	
Reservoirs												
-Structure Safety	✓	✓										x
-Flood Control	✓	✓		✓	✓			✓				x
-Conservation				✓	x							✓
Levees, Channels	✓	✓	✓	✓				✓	x	✓	✓	
Navigation (Stream)	✓			✓				✓	✓		✓	
Int. Drainage		✓	✓		✓	x		✓		✓	✓	x
Stormwater Mgmt.		✓	✓		✓				✓			✓
Flood Insur.	✓	✓		✓	✓			✓				
Non Str. Measures	✓	✓	✓		✓			✓				

1/ General Types - not detailed guide

2/ These are dominate analysis types and not necessarily what would be desired. For example, one would always reconstitute historic events if they were generally available.

(A) Reconstitute historic, (B) Synthetic Event, (C) Changed Response, (D) Historic, (E) From Synthetic, (F) Volume-Duration, (G) Elevation Conversion, (H) Sediment Transport, (I) Routing Data, (J) Facility Sizing, (K) Sequential routing.

3/ ✓ Major, x Less Frequent

CHAPTER 27  
HYDROLOGIC MODELS

General Concepts

A hydrologic model is a computer program that simulates the response of a hydrologic system to meteorologic and streamflow inputs. Existing, historical, or future watershed or river basin conditions may be simulated. The models are used to calculate pertinent hydrologic information at locations of interest in the river basin. There are numerous hydrologic models available ranging from simple to complex analytical concepts. Table 27.1 identifies a few of the models available. Hydrologic models may be grouped in the following categories:

- o Statistical or stochastic models for streamflow generation
- o Simulation models for reproducing the essence of the runoff process
- o Simulation models for evaluating the attributes of water resources mangement activities (structural and nonstructural)
- o Computational procedure programs

Models are usually constructed to perform an analysis for a particular problem/purpose. Therefore, the type of analysis needs to be defined prior to selection of a model. In other words, let the objectives dictate the model use, not the other way around.

Considerations in Selecting Models

Once the study objectives, funds, study time frame, and manpower availability have been defined, there are several important considerations to be made prior to selecting a hydrologic model. They are:

- o Are the manpower input requirements of the model consistent with the study objectives? Manpower costs are usually many times more significant than computer costs.
- o Capacity of program to provide information required for the study.
- o Adequacy of the theoretical basis of the program.

TABLE 27.1 - EXAMPLES OF HYDROLOGIC MODELS

<u>Subject Area</u>	<u>Models</u>
Hydrographs (Precipitation, Losses, Unit graph, Base flow, watershed model)	HEC-1, Flood Hydrograph Package MITCAT, MIT Catchment model TR-20, Soil Conservation Service SWMM, Stormwater management model, EPA STORM, HEC - Storage/Treatment Runoff model SSARR, NPD Streamflow Synthesis and Reservoir Regulation NWSRFS, National Weather Service Stanford Watershed model USGS Dawdy model
Urban Hydrology (changing land use)	SWMM STORM + others above
Flood Routing	HEC-1 and others HEC Unsteady Flow model HEC Stream Hydraulics Package NWS DWOPER RMA-2, Resource Management Associates Corps - MRD, etc.
Water Surface Profiles (inundated area and storage/discharge)	HEC-2, Water Surface Profile WSP2, Soil Conservation Service E431, USGS
Sediment Transport	HEC-6, Scour and Deposition in Rivers and Reservoirs HEC - Deposit of Suspended Sediment Colorado State
Flow Frequency (low-flow frequency)	WRC - Flood Flow Frequency program HEC - Regional Frequency Computation HEC-4 Monthly Streamflow Simulation SEQUEN - Texas Water Development Board (TWDB)
Reservoir Operation (* hydropower)	HEC-1, uncontrolled * HEC-3 conservation * HEC-5 Reservoir System Operation for Flood Control and Conservation SIMYLD, TWDB RESOP, TWDB Corps - SWD, etc.
Dam Safety Hydraulics and Hydrology	HEC-1 Unsteady Flow Stream Hydraulics Package DAMBRK, NWS Fread Corps - MRD

- o Degree to which the model has been tested and verified.
- o Data requirements in relation to data availability and amount of pre-processing required.
- o Ease of application of the program. Factors include model documentation, input structure, diagnostic capabilities, output structure.
- o Data management capabilities (e.g., ability to pass information from one module or sub-program to another).
- o Ease of making program modifications, either in-house or by contract.
- o Program efficiency in terms of typical run times and costs.
- o Program accessibility. Can program be run on a computer that is convenient to access?
- o Accessibility of user-support services (i.e., consultation with someone who is thoroughly familiar with the basic computer code).
- o Quantity and availability of ready-to-use input data for the study area.
- o Usability of models for both continuous and single-event simulation.

### Statistical Models

Statistical or stochastic models for streamflow generation are generally based on the assumptions that streamflow in the future can be predicted from streamflow in the past with unexplained variances accounted for by the addition of a random component. The use of stochastic models is based on the desire to examine consequences of historic hydrology. The arguments in favor of this approach are powerful, but the major applications have been primarily in the academic field. The current state-of-the-art is operational (but with caution) for streamflow generation of long durations (usually monthly volumes) which makes the techniques applicable to conservation studies rather than flood analysis. Some stochastic models, however, are used to generate long records of precipitation that are converted to streamflow used to construct exceedance frequency curves at locations of interest.

The models are usually conceptually simple such as the first order Markov model in which:

$$Q_i = K(Q_{i-1}) + R$$

$Q_i$  = current discharge

$Q_{i-1}$  = previous period discharge

K = constant

R = random component

The term ( $Q_{i-1}$ ) is considered the deterministic portion of the equation.

Probably the most tested stochastic model is HEC [12] which uses linear regression from one month to another and a random component scaled to correlation between the two (first order Markov model). The random component is presumed to be log-normally distributed.

Advantages Of Use of Stochastic Models: The advantages of stochastic models are:

- o Models are simple in concept and operation
- o Requires no detailed knowledge of the hydrologic process
- o Permits evaluation of many future hydrologic alternatives which causes recognition that future runoff conditions of a nonchanging watershed cannot be predicted and could be much different from past records.

Disadvantages of Use of Stochastic Models: The main disadvantages of stochastic models are:

- o Models assume that the degree of persistence between successive flows does not depend on the level of those flows, when in actual flow patterns there is more persistence between low flows than higher flows. Therefore, the models seem to be unable to generate rare sequences of low flows.
- o Many people dislike considering future runoff as actually unknown.
- o Requires some statistical knowledge to enable proper interpretation of results.

## Watershed Simulation Models

Simulation models attempt to recreate the runoff process of the hydrologic system. These models are usually considered as either flood hydrograph models (single event) or continuous synthesis models (period-of-record). Generally, the single event models tend to lump together various components of the hydrologic system (such as loss rates) whereas the continuous models attempt to capture the sequential interaction within the system.

### Flood Hydrograph Models:

- o HEC-1 - Performs flood hydrograph analysis in accordance with traditional Corps procedures. The model permits the reproduction of the storm runoff process for very complex basins with fairly simple parameters. The major advantages of HEC-1 are its acceptance by the Corps, and its flexibility of application on highly urban to highly mountainous and wilderness areas. The main disadvantage of the program is that it is quite empirical and lumped in its concept of the hydrologic system and is limited to single storm events.
- o TR-20 - The Soil Conservation Service TR-20 model performs flood hydrograph analysis similar to HEC-1, except it uses SCS procedures. The model is designed for watersheds with no observed data and therefore is not generally "calibrated" to a runoff event.
- o EPA Stormwater Model - The EPA Stormwater management model performs storm runoff analysis for highly impervious urban areas. The model accepts storm rainfall for each subbasin, calculates excess, and converts rainfall excess to runoff by application of the kinematic wave concept. The model is designed primarily for urban watersheds with fairly high degree of imperviousness (basin for kinematic wave application) and large amounts of curbs, gutters, and storm drains. The flows are also routed using the kinematic wave concepts. The main advantage is its ability to model flow at an extreme level of detail (if that proves to be necessary). The main disadvantage is its limitation to urban areas.

Continuous Synthesis Models: Continuous models are designed to simulate floods and low flows on a continuous basis over a period of many years. The models are usually calibrated for a period of several years of record and the analysis is based on the assumption that the historic record provides the basis for a good prediction of future hydrologies.

- o Stanford Watershed Model (Hydrocomp) - The Stanford Watershed model is by far the most complete and thus complex rainfall runoff synthesis model that has been developed. Its main characteristic is the elaborate soil moisture accounting procedure - the purpose of which is to determine direct runoff, interflow and base flow contributions. Rainfall excess is converted to streamflow through kinematic wave application to overland flow and routes through stream reaches by an extension of the kinematic wave concepts. The model can perform calculations on a very short time interval basis for a continuous period-of-record. The model's limitations are defining all the hydrologic parameters, verification of results, and the expense and experience required for its application.
- o SSARR - The Streamflow Synthesis and Reservoir Regulation (SSARR) model was developed by the North Pacific Division of the Corps and uses a simplified soil moisture accounting procedure to assist in precipitation excess determination. The precipitation excess is converted to streamflow by routing through a hypothetical reservoir. The model, which is very flexible for long and short term time intervals, was derived and has been applied to very large river systems for forecast and operational analysis.
- o STORM Model - The STORM program is primarily a volume accounting model for a single watershed. It uses simple concepts (rational formula and SCS procedures) for the determination of rainfall excess. The model was designed for studies involving storage versus wastewater treatment for urban stormwater runoff, and includes surface washoff water quality routines. The model is attractive because it is easy to understand and use.



## Simulation of Structural and Nonstructural Measures

Operation models are usually designed to accept either historical streamflow or streamflow generated by the previously discussed models. They are used to simulate the operation of water resources facilities to achieve a design objective. A few models include simulation and operation capabilities in a single package, such as SSARR for major reservoir systems and HEC-1 for simple uncontrolled reservoirs. The primary difficulty in development and use of these models is making them sufficiently general for broad applications. Some operation models used for specific water resources facilities include:

- o Simple (uncontrolled) reservoirs
  - HEC-1 using modified Puls routing
  - SCS TR-20 model using modified Puls routing
  - Many other special purpose programs
- o Channel modification evaluations
  - HEC-1/HEC-2 using modified Puls routing
  - SCS model using modified Puls routing
  - HSP with modified channel shapes
- o Major reservoir systems
  - Conservation operations: HEC-3, "Reservoir Systems Analysis for Conservation" and HEC-5, "Simulation of Flood Control and Conservation Systems" are used for reservoir system operation analysis to achieve target flows at downstream control points while observing other constraints of operation.  
Flood control operations: HEC-5 reservoirs in systems that are operated to achieve target flow at a downstream control point (nondamaging channel flow) while observing other constraints of a system or SSARR simulation of the operation of large complex reservoir systems using fixed operating criteria.

## Computational Procedure Programs

Probably the most commonly used computational procedure programs are those that compute water surface profiles. Since the theory is fairly well

developed in the field, a number of programs have been developed that accomplish the same technical objective of comparing water surface elevations by similar methods, i.e., subdivision of conveyance areas of the cross-section and the use of the standard step backwater computation procedure. The HEC-2, Water Surface Profile program, is the most commonly used of these programs, has special features for analyzing channel modifications and encroachments, and has fairly sophisticated techniques for analyzing losses at bridges.

### Summary

Computer models are sufficiently complex that generally an expert is required to operate and interpret the results correctly. Since there are numerous models available it is important to define the study objectives and constraints prior to selection of a model that is the most capable of performing the desired job. A wide variety of other computer models not discussed herein are available from the Hydrologic Engineering Center.

## REFERENCES

## REFERENCES

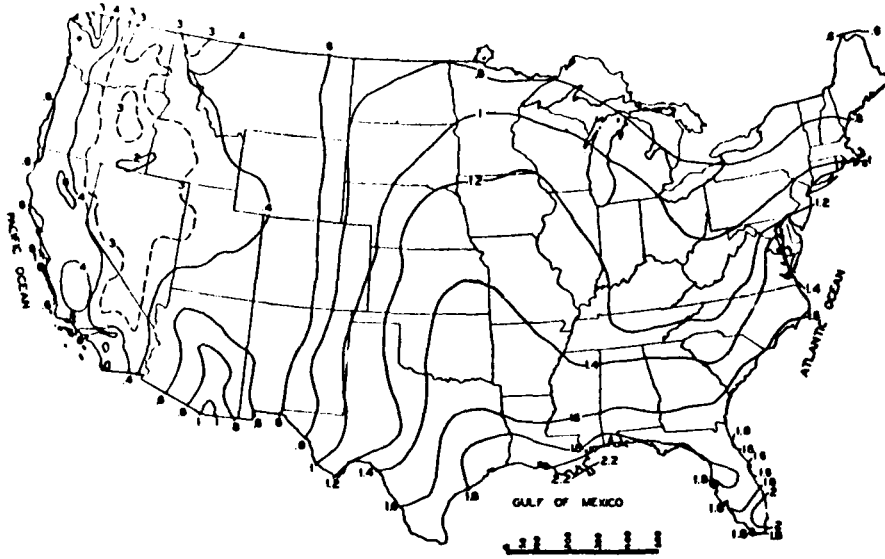
1. Linsley, R. K., M. A. Kohler and J. L. H. Paulhus, Hydrology for Engineers, McGraw-Hill, 1975, Chapters 3, 8, 9, and 11.
2. Beasley, J. G., "An Investigation of the Data Requirements of Ohio for the HEC-2 Water Surface Profile Model," Ohio State University, 1973.
3. "Guidelines for Determining Flood Flow Frequency," U.S. Water Resources Council, Bulletin 17B, September 1981.
4. "Hydrologic Frequency Analysis," Hydrologic Engineering Methods for Water Resources Development, Volume 3, The Hydrologic Engineering Center, April 1975.
5. "Methods of Flow Frequency Analysis," Subcommittee on Hydrology, Inter-Agency Committee on Water Resources, Bulletin 13, April 1966.
6. "Low Flow Frequency," Kansas Streamflow Characteristics, Technical Report 2, Kansas Water Resources Board, June 1960.
7. "Flow Duration," Kansas Streamflow Characteristics, Technical Report 1, Kansas Water Resources Board, June 1959.
8. Leopold, L. B., "Hydrology for Urban Land Planning-A Guidebook on the Hydrologic Effects of Urban Land Use," U.S. Geological Survey, Circular 554, 1968.
9. "Computation of Statistics for Regional Frequency Studies," Training Document No. 4, The Hydrologic Engineering Center, October 1970.
10. "HEC-3, Reservoir Systems Analysis for Conservation," Users Manual, The Hydrologic Engineering Center, March 1981.

REFERENCES (Continued)

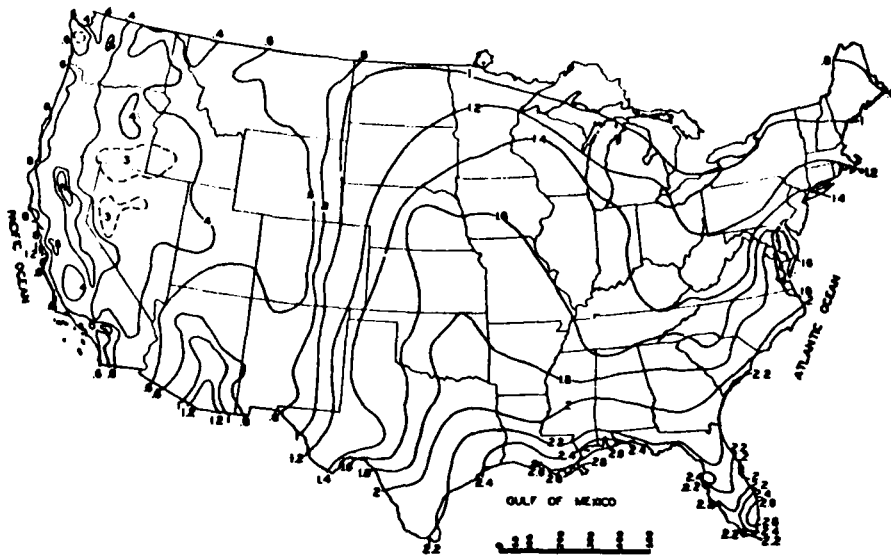
11. "HEC-5, Simulation of Flood Control and Conservation System," Users Manual, The Hydrologic Engineering Center, June 1979.
12. "HEC-4, Monthly Streamflow Simulation," Users Manual, The Hydrologic Engineering Center, February 1971.

APPENDIX A

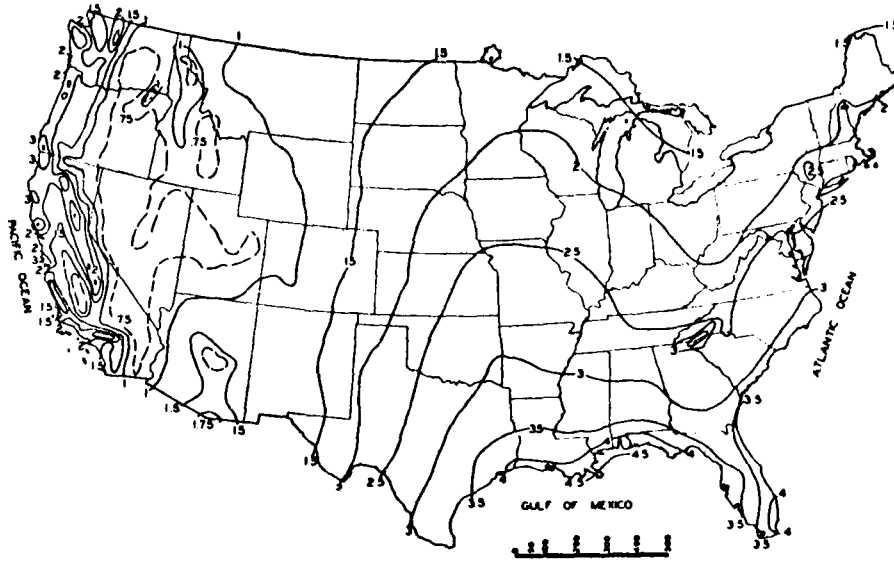
POINT RAINFALL ATLAS OF THE UNITED STATES



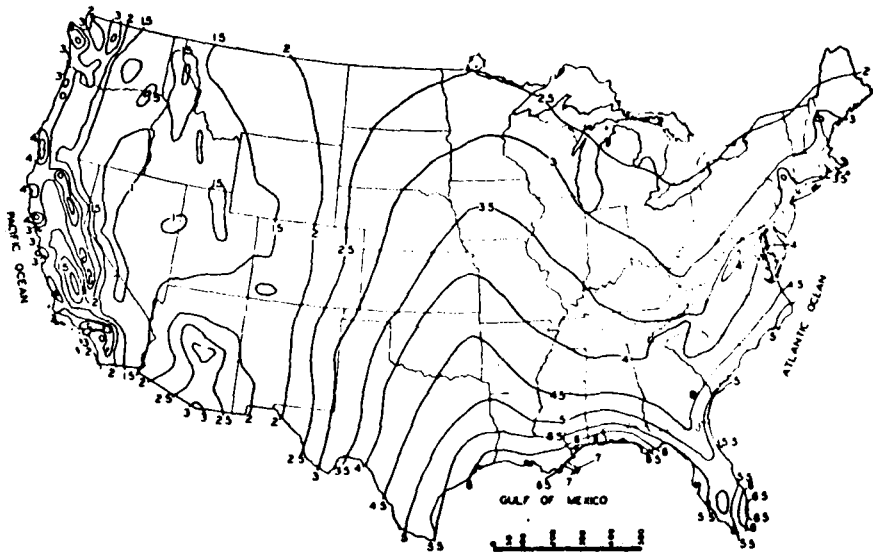
**FIG. A - 1 Two-year 30-minute rainfall (inches) (10).**



**FIG. A - 2 Two-year 1-hour rainfall (inches) (10).**

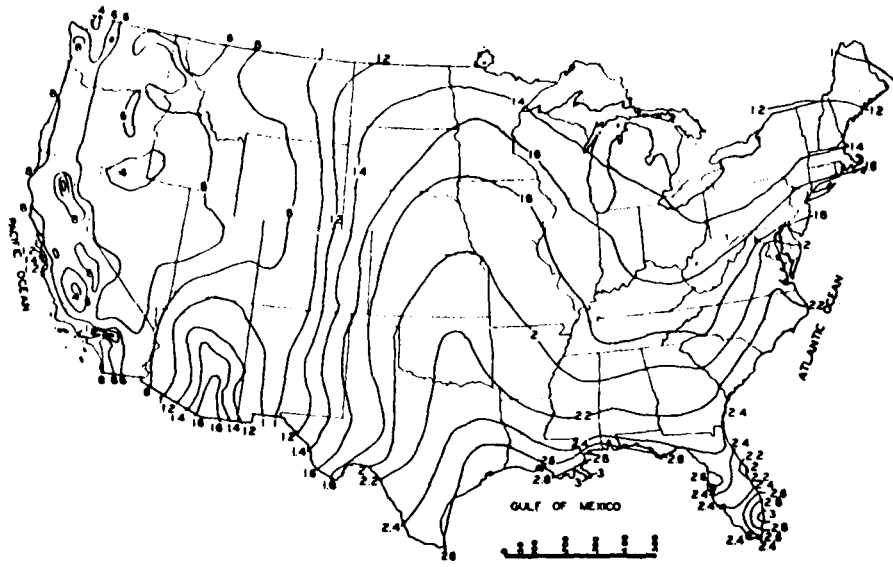


**FIG. A - 3 Two-year 6-hour rainfall (inches) (10).**

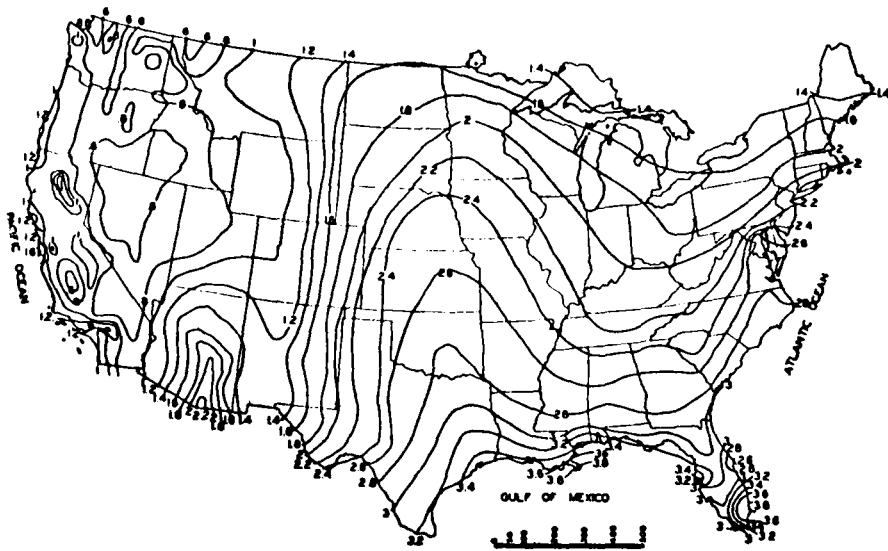


**FIG. A - 4 Two-year 24-hour rainfall (inches) (10).**

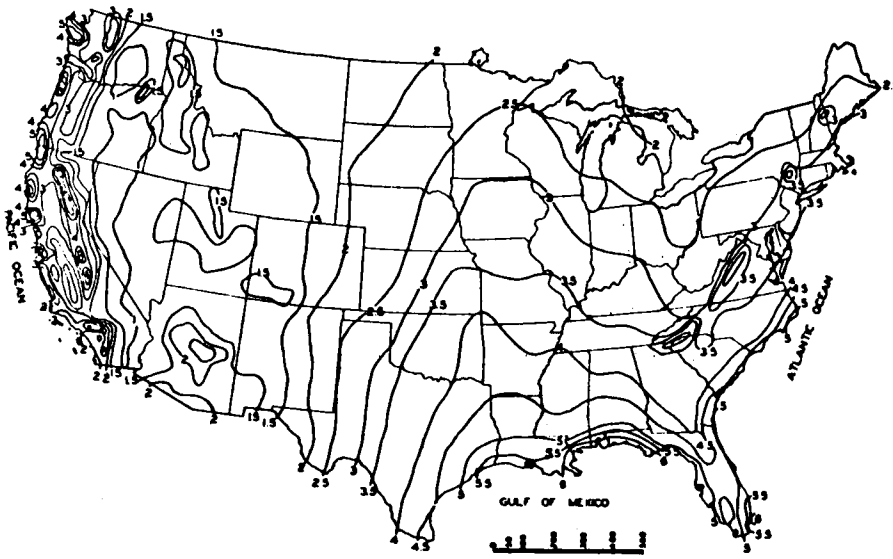




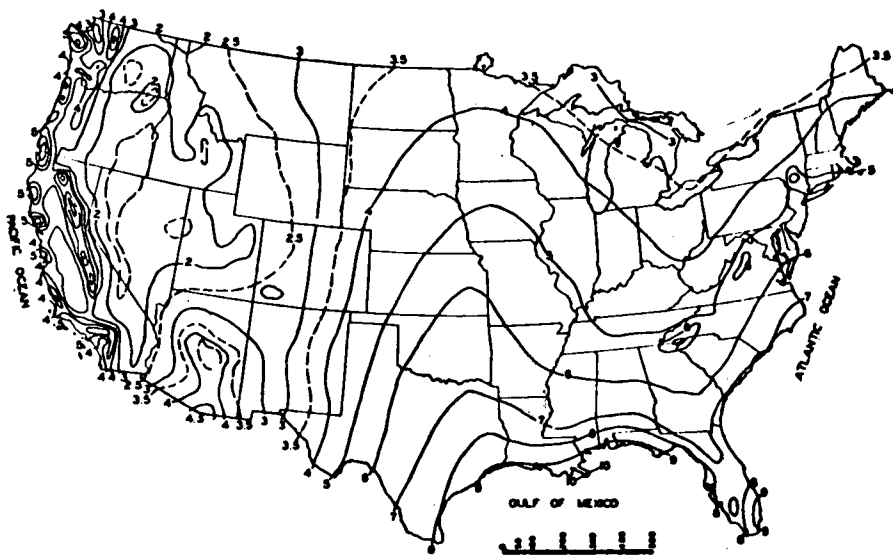
**FIG. A - 5 Ten-year 30-minute rainfall (inches) (10).**



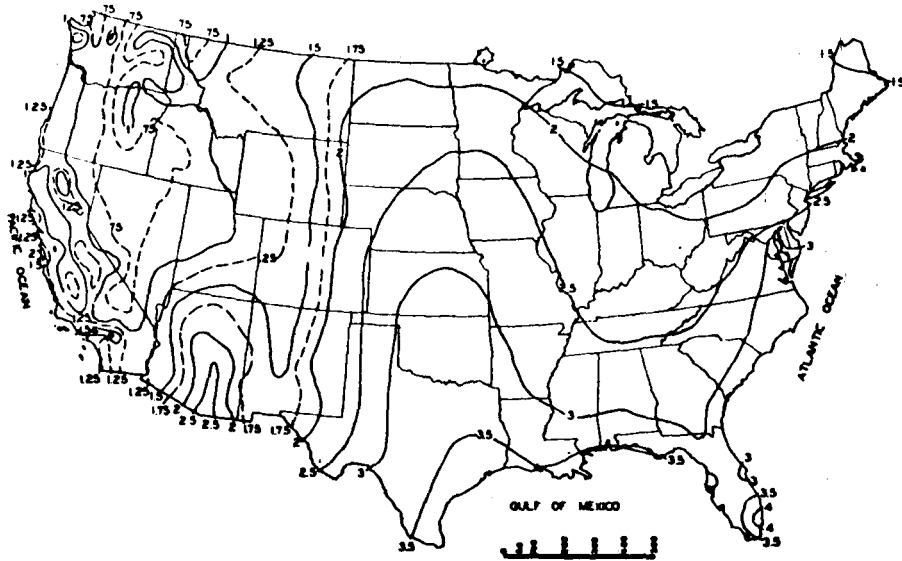
**FIG. A - 6 Ten-year 1-hour rainfall (inches) (10).**



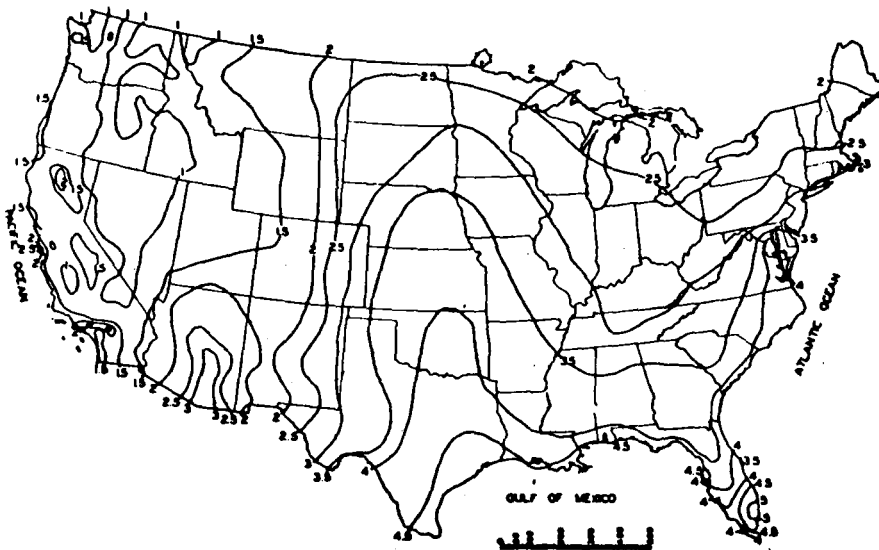
**FIG. A - 7 Ten-year 6-hour rainfall (inches) (10).**



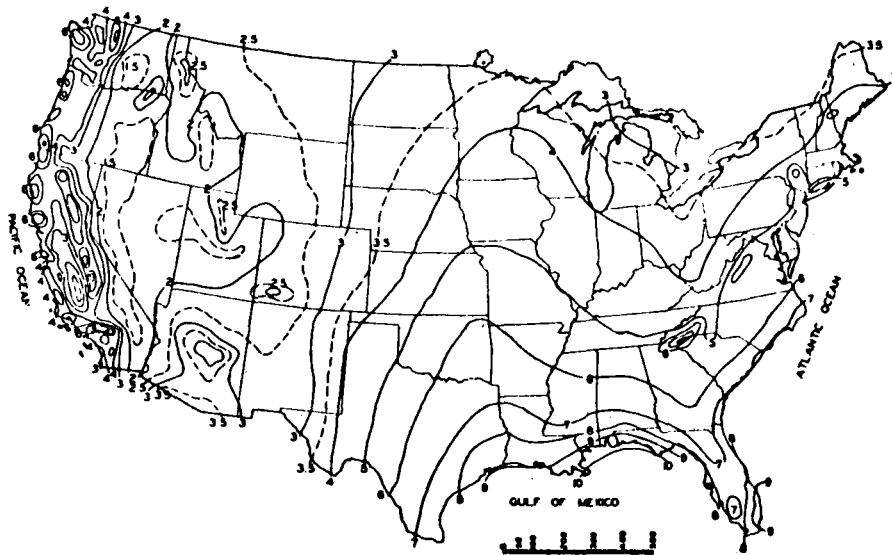
**FIG. A - 8 Ten-year 24-hour rainfall (inches) (10).**



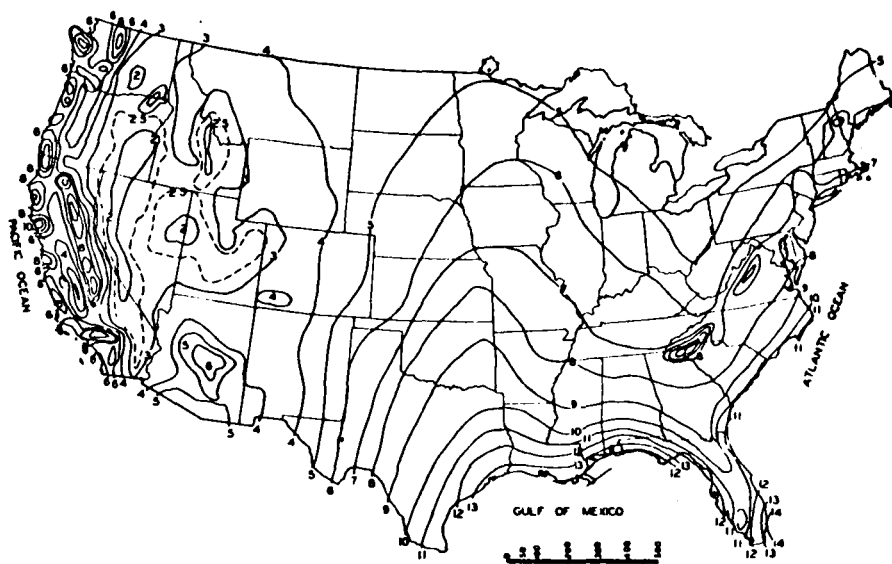
**FIG. A - 9 One-hundred-year 30-minute rainfall (inches) (10).**



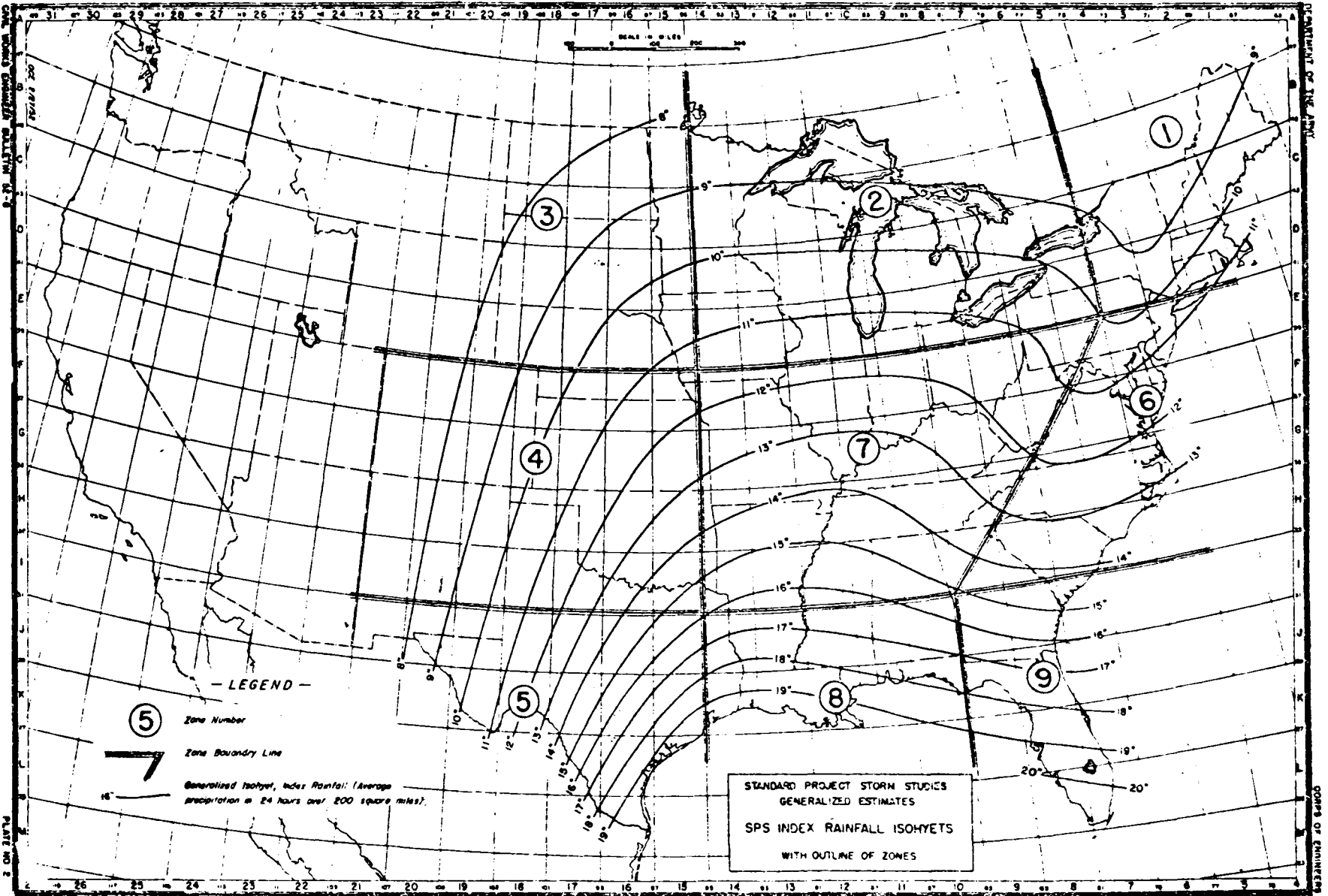
**FIG. A - 10 One-hundred-year 1-hour rainfall (inches) (10).**



**FIG. A - 1 1 One-hundred-year 6-hour rainfall (inches) (10).**



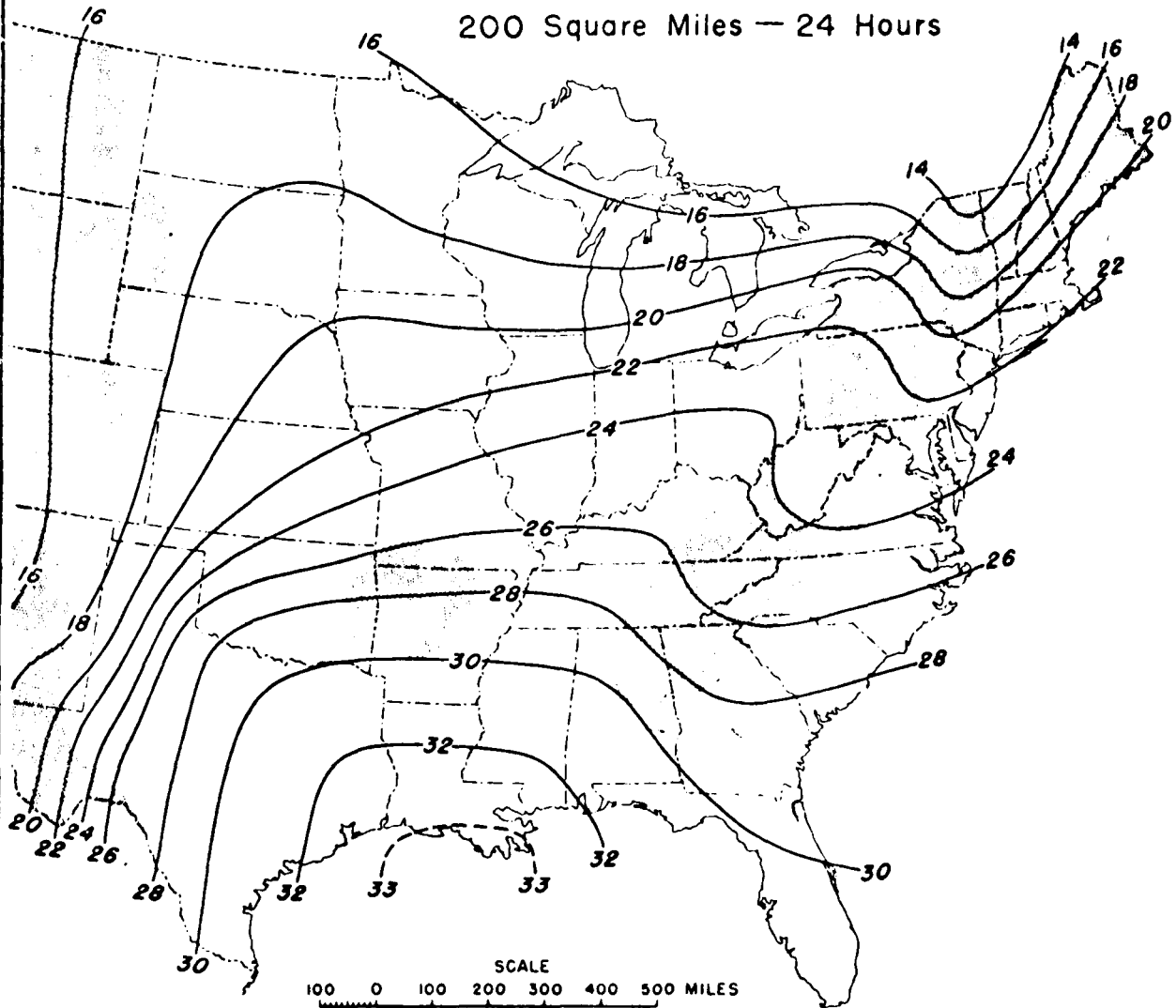
**FIG. A - 1 2 One-hundred-year 24-hour rainfall (inches) (10).**



A.7

Figure A-13

# GENERALIZED ESTIMATES MAXIMUM POSSIBLE PRECIPITATION



*This plate is reproduced from H.M.S. Report No. 23 prepared by the Hydrometeorological Section of the U.S. Weather Bureau.*

APPENDIX B

SENSITIVITY ANALYSIS OF FACTORS THAT  
INFLUENCE WATER SURFACE PROFILES

October 1970

## SENSITIVITY ANALYSIS OF FACTORS THAT INFLUENCE WATER SURFACE PROFILES

### 1. PURPOSE AND SCOPE OF STUDY

The purpose of this study is to determine the response of a calculated water surface profile to selected variations in boundary roughness, discharge, cross section geometry and longitudinal valley slope. One basic study reach and a discharge corresponding to the 100-year peak flood were chosen for consideration.

### 2. DESCRIPTION OF STUDY REACH

The study reach is a 6-mile long section of Line Creek, a tributary to the Tibbee River in eastern Mississippi. The valley width in the study reach is about 1 1/2 miles and the valley slope (longitudinal) is about 3 feet per mile. Vegetation in the reach is primarily virgin hardwood timber. The primary source of topographic data is U. S. Geologic Survey Quadrangle sheets having a scale of 1:24000 and a contour interval of 20 feet. In addition, a few surveyed cross sections are available. A rating curve at each end of the study reach as well as a few observed profiles are also available.

### 3. VERIFICATION OF THE MODEL

In developing a model of the study reach, a channel bed profile and a profile along the top bank were determined from Quad sheets. These were adjusted to fit the survey data. In addition, cross sections taken from Quadrangle sheets were reshaped using the surveyed sections as a guide. Seven cross sections were used in the geometric model for the study reach. A typical cross section is shown in exhibit 3. Computer program HEC-2, which calculates water surface profiles by the standard step method as described in the Corps of Engineers Engineering Manual 1110-2-1409, "Backwater Curves in River Channels," was used. Manning's n-values were adjusted so that calculated water surface profiles would reproduce the rating curve at the upstream end of the reach. Adopted n-values were .048 for the channel and .072 for the overbanks. The final water surface profile for a discharge of 30,000 cfs (100-year flood peak) is shown in exhibit 1 and defined as Base Test 1. The influence of the starting water surface elevation at the downstream end of the reach does not extend more than about 3 miles upstream. That is, the upstream portion of the profile is a "normal depth" profile controlled completely by boundary resistance.



#### 4. DESCRIPTION OF TESTS

A set of tests was run using selected variations in n-values, cross sectional geometry and discharge for the study reach described in the preceding paragraph. Two additional sets of tests were run in which the geometric model was "titled" to valley slopes of 10 feet per mile and 1 foot per mile. The following runs were made for each of the three valley slopes:

a. Influence of n-Values. The n-values developed for the base test were doubled. The resulting influence on the water surface profile is shown in exhibit 2. Although the n-values are rather high, they are not unreasonable for densely wooded bottom land.

b. Influence of Geometric Model. A geometric model (i.e., cross sections) was developed by using only data from Quad sheets. A sample of the difference in cross section shape between surveyed sections and Quad sheet sections is shown in exhibit 3. This run was made to illustrate the sensitivity of water surface profiles to a crude geometric model, and reflects only errors in vertical control of cross sections.

c. Influence of Discharge. The discharge utilized in the base test was arbitrarily increased by 25% and decreased by 25% to illustrate the sensitivity of water surface profiles to errors in the amount of flow.

#### 5. DISCUSSION OF RESULTS

Depth profiles for each run are shown in exhibit 2. Exhibit 4 is a table in which results of the tests are compared at the upstream end of the study reach.

a. Influence of n-Values. The doubled n-values increased the water surface profile by about 2.5 feet for the valley slope of 1 foot per mile and 1.5 feet for the valley slope of 10 feet per mile. The influence of the "n" tends to increase as valley slope decreases.

b. Influences of Geometric Model. Profiles developed with the crude geometric model are more erratic than those for base test conditions in all three tests. The water surface was about 1.5 feet high for the valley slope of 1 foot per mile and 2.5 feet high for the valley slope of 10 feet per mile. The influence of the inaccuracies in the crude geometric model tends to increase with increasing valley slope. The cross sections obtained from Quad sheets had less area than comparable surveyed cross sections. This is because cross sections tend to be concave up, and those scaled from Quad sheets are constructed by assuming that the ground surface is linear between contour lines, as illustrated in exhibit 3. In general, therefore, the use of cross sections from Quad sheets will tend to produce water surface profiles that are too high.

c. Influence of Discharge. It can be noted from exhibit 2 that the influence of errors in discharge decreases with increasing valley slope. A 25% error in discharge influenced the water surface elevations by less than a foot, even for a valley slope of 1 foot per mile.

d. Cumulative Errors. To illustrate the influence of accumulating errors, a run was made using the crude geometric model with a valley slope of 3 feet per mile doubled n-values and a discharge that is 25% high. The resulting water surface profile is shown as Run 6 on exhibit 1. It is above the Base Test 1 profile by as much as 5 feet.

## 6. CONCLUSIONS

Although the test conditions selected for this study are not generally applicable for the entire range of conditions that will be encountered in flood insurance studies, the test conditions are reasonably typical, both with respect to magnitude of discharge and data sources, of many of the studies that will be made. This study is intended to give some feel for the relative importance of parameters that are used in calculating water surface profiles.

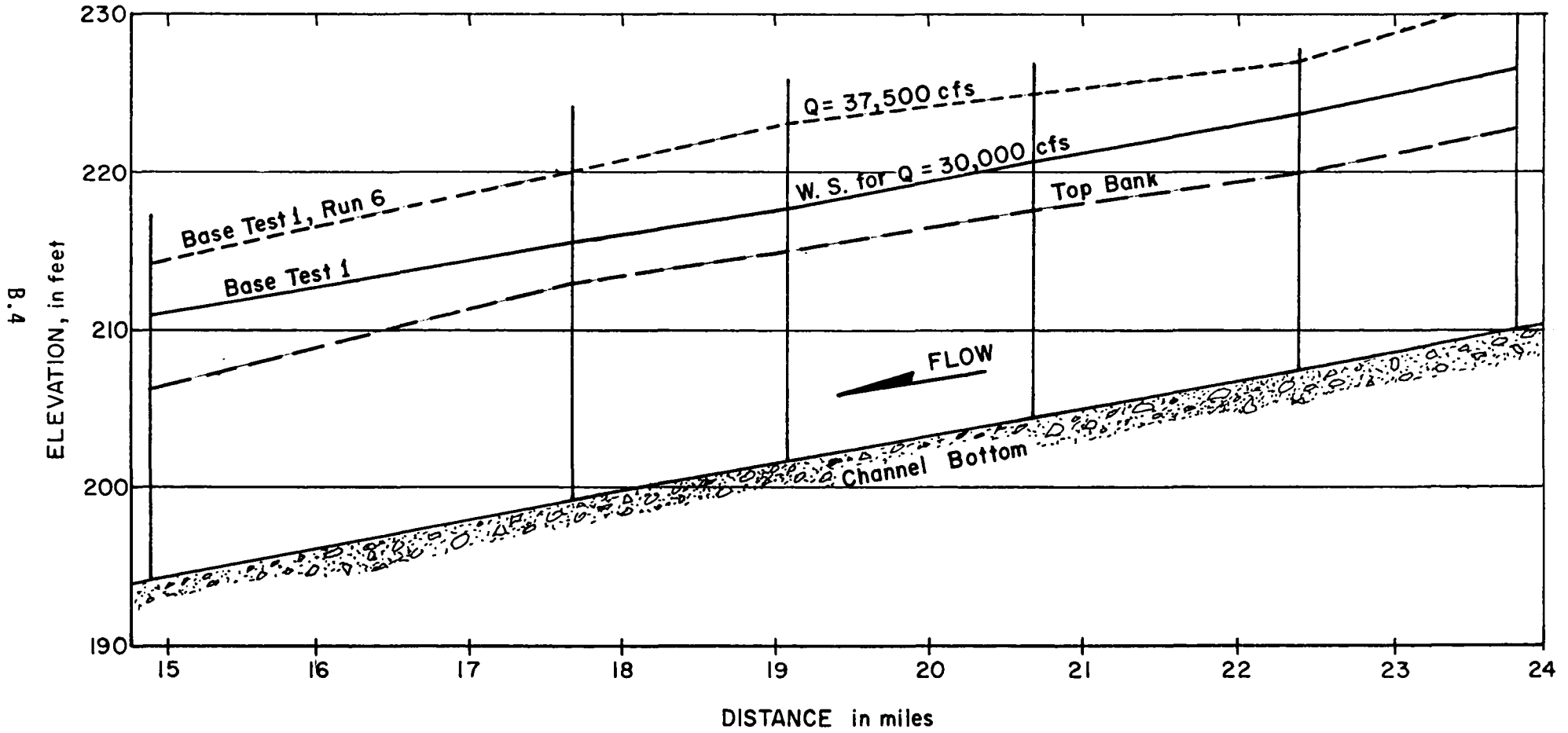
The sensitivity of profiles to errors in both n-values and discharge tends to increase as valley slope decreases. The sensitivity of profiles to errors in geometry appear to decrease with decreasing valley slope.

For the test conditions selected, the profiles on exhibit 2 show the most sensitivity of n-values, somewhat less sensitivity to the geometric model, and least sensitivity to discharge. It should be recalled, however, that n-values were doubled and discharge varied by only 25% in this study.

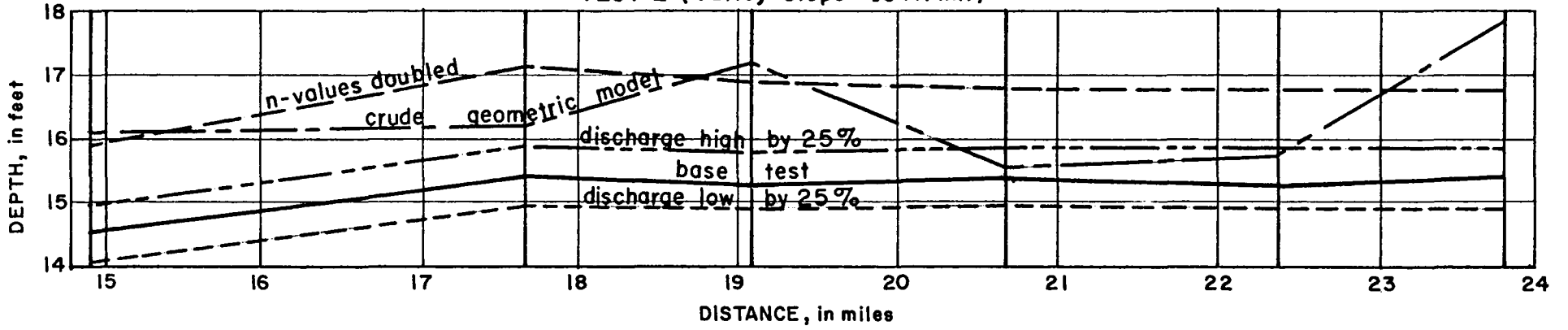
The doubled n-values were the values actually selected prior to verification to the model. If these had been used together with a crude geometric model scaled from available Quadrangle sheets, the resulting water surface profile would have been high by as much as 4 feet.

This study demonstrates that short cut procedures should not be used for calculating water surface profiles unless there is some knowledge about the extent of their influence on the calculated values.

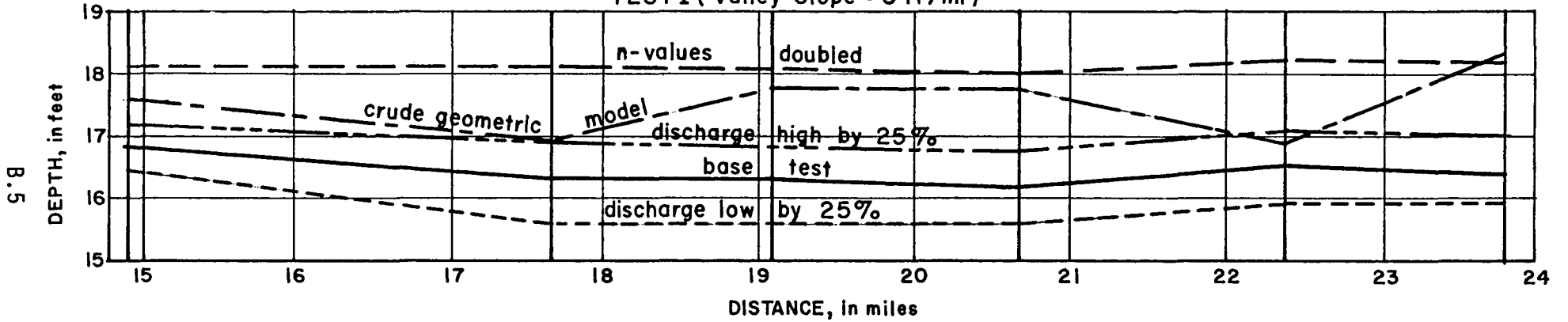
SENSITIVITY STUDY  
PROFILES  
OCT. 1970



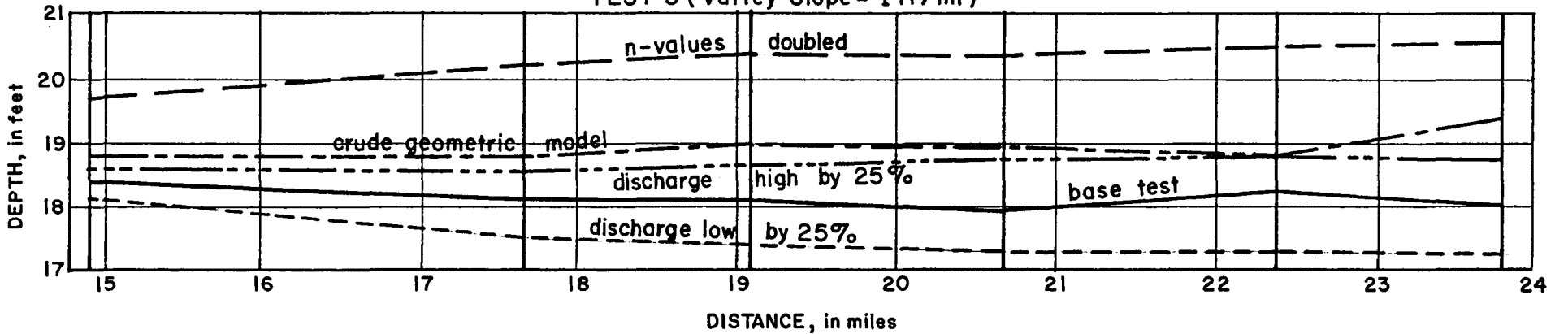
TEST 2 (Valley Slope = 10ft/mi.)



TEST 1 (Valley Slope = 3 ft/mi)



TEST 3 (Valley Slope = 1 ft/mi)



SENSITIVITY STUDY  
CROSS SECTION SHAPE  
OCT. 1970

B.6

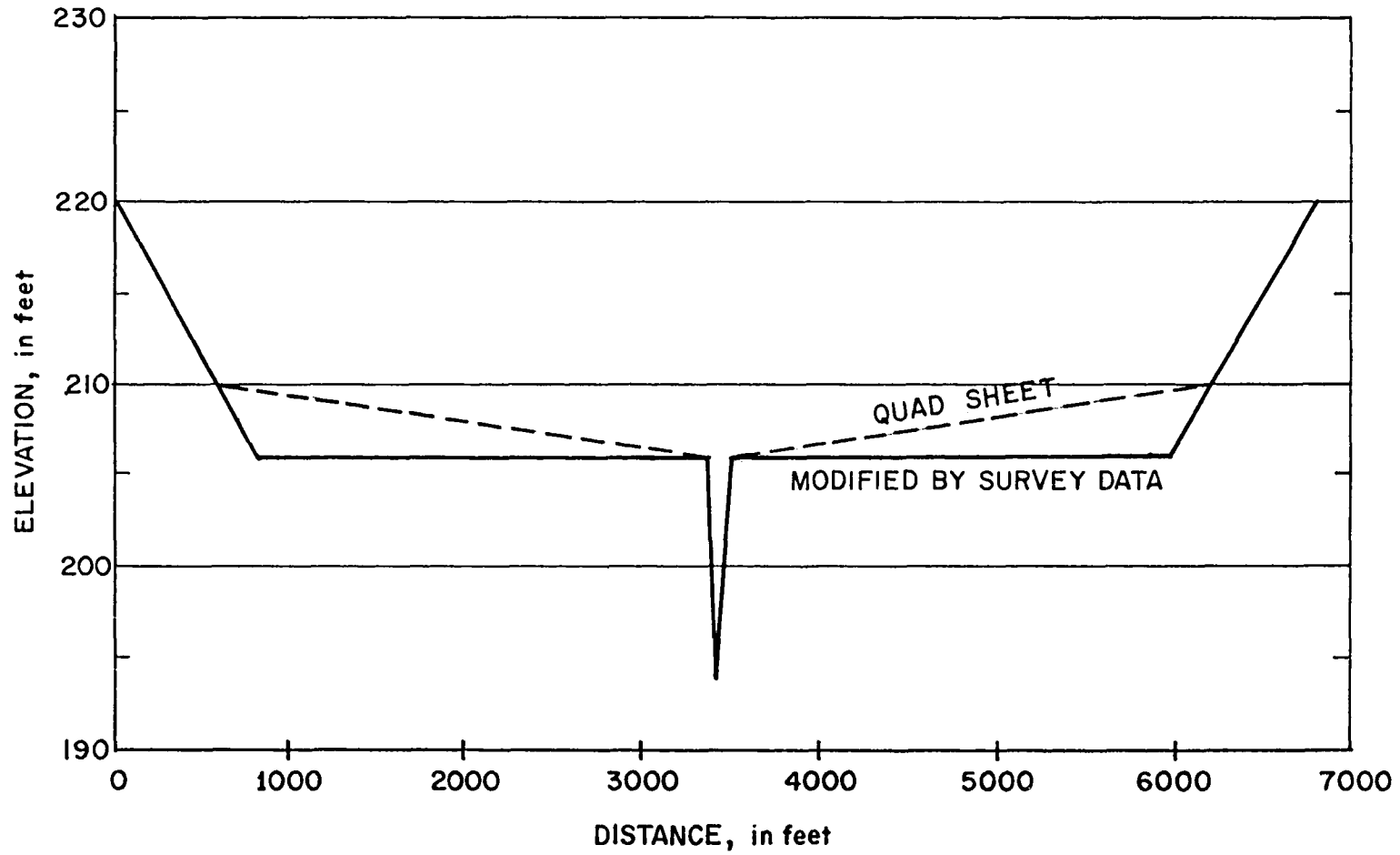


EXHIBIT 4

DEPTH AT UPSTREAM END OF STUDY REACH (Section 23.82)

	Valley Slope ~ 1 ft./mi.		Valley Slope ~ 3 ft./mi.		Valley Slope ~ 10 ft/ mi.	
	Depth ft.	Error* ft.	Depth ft.	Error* ft.	Depth ft.	Error* ft.
Base	18.1		16.5		15.4	
Discharge Low By 25%	17.3	- .8	15.9	- .6	14.9	- .5
Discharge High By 25%	18.8	+ .7	17.0	+ .5	15.8	+ .4
n-Value Doubled	20.5	+ 2.4	18.7	+ 1.8	16.8	+ 1.4
Crude Geometric Model	19.5	+ 1.4	18.5	+ 2.0	17.8	+ 2.4

B.7

\* Error is defined as the difference between a given depth and the depth for the corresponding base run.

APPENDIX C

BIBLIOGRAPHY

APPENDIX C  
BIBLIOGRAPHY

PUBLICATIONS ON HYDROGRAPH ANALYSIS

"A Primer on Water," U.S. Department of the Interior, Geological Survey, U.S. Government Printing Office, Washington, D.C., 1960.

Beard, L. R., "Hypothetical Floods," Hydrologic Engineering Methods for Water Resources Development, Volume 5, Hydrologic Engineering Center, 1975.

Beasley, J. G., "An Investigation of the Data Requirements of Ohio for the HEC-2 Water Surface Profile Model," Ohio State University, 1973.

"Hydrograph Analysis," Hydrologic Engineering Methods for Water Resources Development, Volume 5, Hydrologic Engineering Center, 1975.

"HEC-1, Flood Hydrograph Package," Users Manual, Hydrologic Engineering Center, 1981.

Hjelmfelt, A.T., Jr., and J. J. Cassidy: Hydrology for Engineers and Planners, pages 51-151, Iowa State University Press, Ames, Iowa, 1975.

Linsley, R. K., M. A. Kohler and J. L. H. Paulhus, Hydrology for Engineers, McGraw-Hill, 1975.

Linsley, R. K. and J. B. Franzini, Water Resources Engineering, McGraw-Hill, 1979.

PUBLICATIONS ON FLUVIAL HYDRAULICS

Chow, V. T., Open-Channel Hydraulics, McGraw-Hill, 1959.

"HEC-2, Water Surface Profiles," Users Manual, The Hydrologic Engineering Center, 1981.



Henderson, F. M., Open Channel Flow, McMillan, 1966.

Morisawa, M., Streams, their dynamics and morphology, McGraw-Hill, 1968.

"Sedimentation Engineering," Manuals and Reports on Engineering Practice No. 54, American Society of Civil Engineers.

Thomas, W. A., "Water Surface Profiles," Hydrologic Engineering Methods for Water Resources Development, Volume 6, The Hydrologic Engineering Center, July 1975.

Thomas, W. A., "Sediment Transport," Hydrologic Engineering Methods for Water Resources Development, Volume 12, The Hydrologic Engineering Center, 1976.

Vevjevich, V. M., "Bibliography and Discussion of Flood Routing Methods and Unsteady Flow in Channels," U.S. Geological Survey, Water Supply Paper 1690, 1964.

#### PUBLICATIONS ON FREQUENCY ANALYSIS

"Computation of Statistics for Regional Frequency Studies," Training Document No. 4, The Hydrologic Engineering Center, October 1970.

"Expected Annual Flood Damage Computation," Users Manual, June 1977, Exhibit 1.

"Flow Duration," Kansas Streamflow Characteristics, Technical Report 1, Kansas Water Resources Board, June 1959.

"Guidelines for Determining Flood Flow Frequencies," U.S. Water Resources Council, Bulletin 17B, September 1981.

"Hydrologic Frequency Analysis," Hydrologic Engineering Methods for Water Resources Development, Volume 3, The Hydrologic Engineering Center, April 1975.

Johnson, W. K., and D. W. Davis, "Analysis of Structural and Nonstructural Flood Control Measures Using Computer Program HEC-5C," Training Document No. 7, The Hydrologic Engineering Center, November 1975.

Leopold, L. B., "Hydrology for Urban Land Planning -- A Guidebook on the Hydrologic Effects of Urban Land Use," U.S. Geological Survey, Circular 554, 1968.

Linsley, R. K., and J. B. Franzini, Water Resources Engineering, McGraw-Hill, 1972, pages 132-136.

Linsley, R. K., et al., Hydrology for Engineers, McGraw-Hill, 1975, pages 356-360.

"Low Flow Frequency," Kansas Streamflow Characteristics, Technical Report 2, Kansas Water Resources Board, June 1960.

"Methods of Flow Frequency Analysis," Subcommittee on Hydrology, Inter-Agency Committee on Water Resources, Bulletin 13, April 1966.

#### PUBLICATIONS ON RESERVOIR YIELD STUDIES

"HEC-3, Reservoir Systems Analysis for Conservation", Users Manual, The Hydrologic Engineering Center, March 1981.

"HEC-5, Simulation of Flood Control and Conservation Systems," Users Manual, The Hydrologic Engineering Center, June 1979.

"Monthly Streamflow Simulation," Users Manual, The Hydrologic Engineering Center, February 1971.

"Reservoir Storage Yield Procedures," Method Systemization Manual, The Hydrologic Engineering Center, Davis, California, 1967.

Riggs, N. C., "Low Flow Investigations," Chapter B1, U.S. Department of Interior, U.S. Geological Survey, 1969.

## MANAGING HYDROLOGIC STUDIES

Brandstetter, A., "Assessment of Mathematical Models for Storm and Combined Sewer Management," EPA Environmental Protection Technology Series, EPA Report 600/2-76-175a, Washington, D.C., August 1976.

Brown, J. W., et al, "Models and Methods Applicable to Corps of Engineers Urban Studies," Waterways Experiment Station, U.S. Army Corps of Engineers, Miscellaneous Paper H-74-8, Vicksburg, Mississippi, August 1974.

"Review of Computer Simulation Models for Analyzing Chicagoland Underflow Plan Alternatives," Special Projects Memo No. 80-5, The Hydrologic Engineering Center, September 1980.

REPORT DOCUMENTATION PAGE		READ INSTRUCTIONS BEFORE COMPLETING FORM
1. REPORT NUMBER Training Document No. 14	2. GOVT ACCESSION NO.	3. RECIPIENT'S CATALOG NUMBER
4. TITLE (and Subtitle) HYDROLOGIC ENGINEERING IN PLANNING		5. TYPE OF REPORT & PERIOD COVERED
		6. PERFORMING ORG. REPORT NUMBER
7. AUTHOR(s) Mike Burnham, Bill Johnson and Darryl Davis		8. CONTRACT OR GRANT NUMBER(s)
9. PERFORMING ORGANIZATION NAME AND ADDRESS US Army Corps of Engineers The Hydrologic Engineering Center 609 Second Street, Davis, CA 95616		10. PROGRAM ELEMENT, PROJECT, TASK AREA & WORK UNIT NUMBERS
11. CONTROLLING OFFICE NAME AND ADDRESS		12. REPORT DATE April 1991
		13. NUMBER OF PAGES 346
14. MONITORING AGENCY NAME & ADDRESS (if different from Controlling Office)		15. SECURITY CLASS. (of this report) Unclassified
		15a. DECLASSIFICATION/DOWNGRADING SCHEDULE
16. DISTRIBUTION STATEMENT (of this Report)  Distribution of this publication is unlimited		
17. DISTRIBUTION STATEMENT (of the abstract entered in Block 20, if different from Report)		
18. SUPPLEMENTARY NOTES  Training course manual, "Hydrologic Engineering in Planning"		
19. KEY WORDS (Continue on reverse side if necessary and identify by block number)  Hydrologic engineering; hydrology; hydraulics; statistical methods.		
20. ABSTRACT (Continue on reverse side if necessary and identify by block number)  This manual is intended as instructive material which presents the basic purpose, concepts and methodologies of hydrologic engineering. It is organized into three main sections: Hydrograph Analysis, Fluvial Hydraulics, and Frequency Analysis. Also, covered are Reservoir Yield Studies and Managing Hydrologic Studies.		

