

134
H-68-10

TECHNICAL REPORT H-68-10

NAVIGATION CONDITIONS AT OZARK LOCK AND DAM, ARKANSAS RIVER

Hydraulic Model Investigation

by

J. J. Franco

C. D. McKellar, Jr.

AD 723 952



November 1968

Sponsored by

U. S. Army Engineer District
Little Rock

Conducted by

U. S. Army Engineer Waterways Experiment Station
CORPS OF ENGINEERS
Vicksburg, Mississippi

THIS DOCUMENT HAS BEEN APPROVED FOR PUBLIC RELEASE
AND SALE; ITS DISTRIBUTION IS UNLIMITED

LIBRARY
US ARMY ENGINEER WATERWAYS EXPERIMENT STATION
VICKSBURG, MISSISSIPPI

\$1.50

TECHNICAL REPORT H-68-10

NAVIGATION CONDITIONS AT OZARK LOCK AND DAM, ARKANSAS RIVER

Hydraulic Model Investigation

by

J. J. Franco

C. D. McKellar, Jr.



November 1968

Sponsored by

U. S. Army Engineer District
Little Rock

Conducted by

U. S. Army Engineer Waterways Experiment Station
CORPS OF ENGINEERS
Vicksburg, Mississippi

ARMY-MRC VICKSBURG, MISS.

THIS DOCUMENT HAS BEEN APPROVED FOR PUBLIC RELEASE
AND SALE; ITS DISTRIBUTION IS UNLIMITED

W34
No. H-68-10

FOREWORD

The model investigation reported herein was authorized by the Office, Chief of Engineers, in an indorsement dated 2 May 1963, to the Division Engineer, U. S. Army Engineer Division, Southwestern.

The study was conducted for the U. S. Army Engineer District, Little Rock, during the period June 1963 to November 1965 in the Hydraulics Division of the U. S. Army Engineer Waterways Experiment Station under the general supervision of Mr. E. P. Fortson, Jr., Chief of the Hydraulics Division, and Mr. G. B. Fenwick, Assistant Chief, and under the direct supervision of Mr. J. J. Franco, Chief of the Waterways Branch. The engineer in immediate charge of the model was Mr. C. D. McKellar, Jr., assisted by Messrs. H. S. Austin, S. T. Mattingly, John A. Holliday, B. C. Rawls, R. T. Wooley, D. E. Barnes, and T. P. Williams. This report was prepared by Messrs. Franco and McKellar.

During the course of the model study, the Little Rock District was advised of the progress of the study through monthly progress reports and interim reports of special tests. In addition, GEN C. H. Dunn, Messrs. R. D. Field, E. B. Madden, R. H. Berryhill, G. A. Makela, and H. C. Maxon of the Southwestern Division; Messrs. E. F. Rutt, J. C. Pyle, W. W. McMahon, W. A. Thomas, J. T. Clements, Jr., Tasso Schmidgall, C. W. Shelton, and Misses Irene Miller and Margaret Petersen of the Little Rock District visited the Waterways Experiment Station at intervals to observe model tests and discuss test results.

Directors of the Waterways Experiment Station during the conduct of the tests and preparation and publication of this report were COL Alex G. Sutton, Jr., CE, COL John R. Oswalt, Jr., CE, and COL Levi A. Brown, CE. Technical Director was Mr. J. B. Tiffany.

CONTENTS

	<u>Page</u>
FOREWORD	iii
CONVERSION FACTORS, BRITISH TO METRIC UNITS OF MEASUREMENT	vii
SUMMARY	ix
PART I: INTRODUCTION	1
Present Development Plan for the Arkansas River	1
Description of Structures and Improvements	2
Purpose of Model Study	4
PART II: THE MODEL	5
Description	5
Scale Relations	6
Model Adjustment	7
PART III: TEST RESULTS	9
Test Procedure	9
Plan A	10
Plan B	11
Plan C	12
Plan D	13
Plans E, E-1, and E-2	15
Plan F	15
Plan G	17
Powerhouse Release Studies	18
Tests with Flood Flows	19
Head on Lock Gate	20
PART IV: DISCUSSION OF RESULTS AND CONCLUSIONS	21
Limitation of the Model	21
Conclusions	21

Tables 1-13

Photographs 1-15

Plates 1-19

CONVERSION FACTORS, BRITISH TO METRIC UNITS OF MEASUREMENT

British units of measurement used in this report can be converted to metric units as follows:

<u>Multiply</u>	<u>By</u>	<u>To Obtain</u>
inches	2.54	centimeters
feet	0.3048	meters
miles	1.609344	kilometers
square feet	0.092903	square meters
feet per second	0.3048	meters per second
cubic feet per second	0.0283168	cubic meters per second

SUMMARY

Ozark Lock and Dam will consist of a 110- by 600-ft lock and an 890-ft-long, gated, nonnavigable dam. A 1:120-scale, fixed-bed model, reproducing 2.7 miles of the Arkansas River, was used to: (a) demonstrate flow conditions in the lock approaches; (b) measure the distribution of flow across the model at the axis of the dam for a number of flows; (c) determine velocities at various points on the overbank in the vicinity of the structures for a number of flows; and (d) assist in developing modifications of the approaches and structures to improve navigation conditions. Tests were concerned with the study of flow patterns, measurement of velocities in the lock approaches, and behavior of a model tow on entering and leaving the lock. The results of the investigation indicated the following:

- a. Modifications of the original design would be required to develop satisfactory navigation conditions in the lock approaches.
- b. Excavation for the entrance to the powerhouse can be reduced and flow distribution into the powerhouse can be improved by realignment of the upstream bankline.
- c. Sudden powerhouse releases could produce conditions hazardous to navigation and some limitation should be placed on the rate of increase in powerhouse discharge.
- d. The maximum head differential on the downstream lock gate during lock emptying could be as much as 0.6 ft during the higher flows.

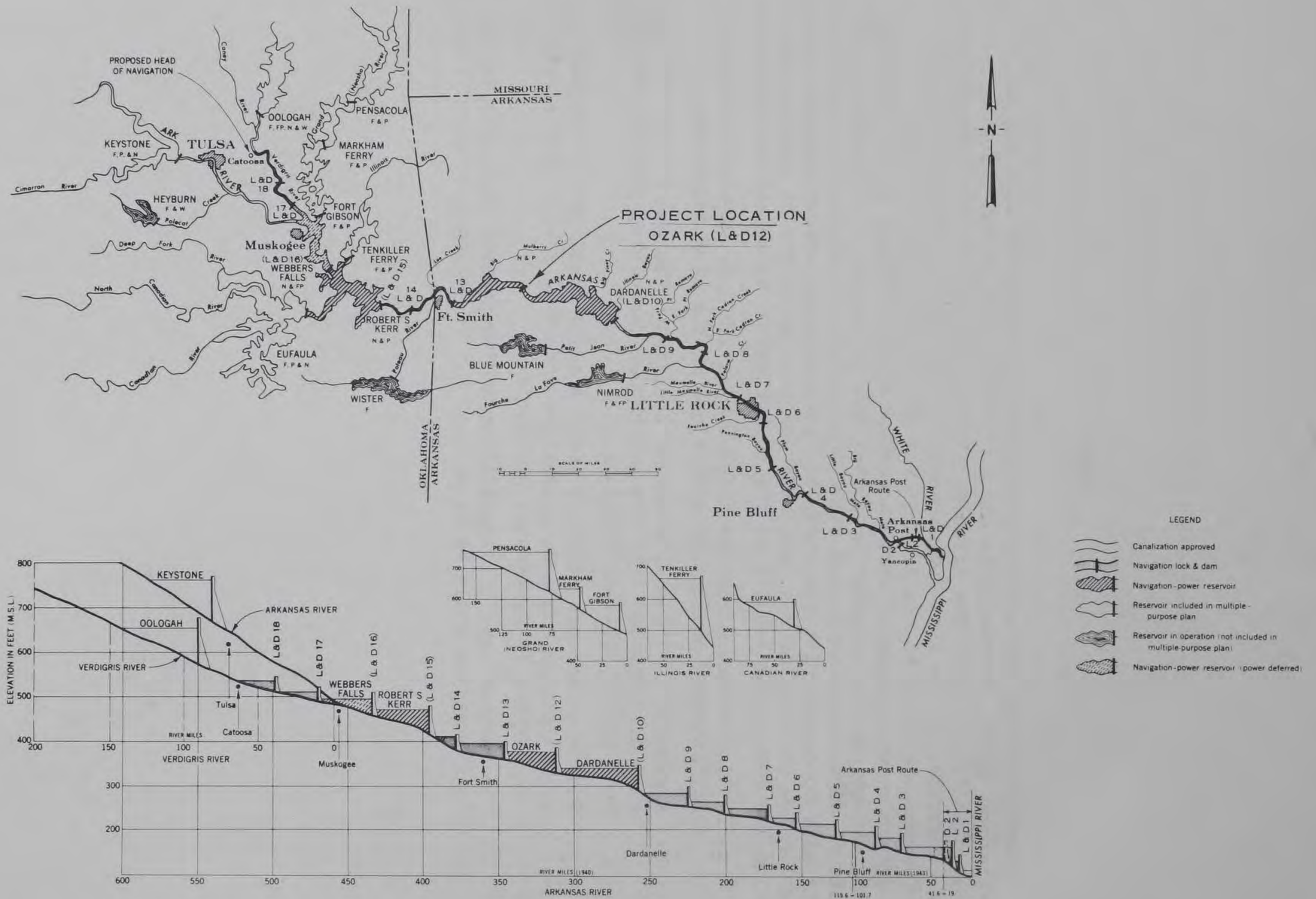

Fig. 1. Vicinity map

NAVIGATION CONDITIONS AT OZARK LOCK AND DAM

ARKANSAS RIVER

Hydraulic Model Investigation

PART I: INTRODUCTION

Present Development Plan for the Arkansas River

1. The Arkansas River is considered a navigable stream from its mouth to its confluence with the Verdigris River (fig. 1). In this section, the slope of the stream averages 0.9 ft per mile* above Little Rock, and 0.7 ft per mile between Little Rock and the Mississippi River. Water-surface elevations and slopes in the lower river are affected by backwater from the Mississippi; these effects at times extend as far upstream as Pine Bluff, mile 111. During periods of low water, the controlling depth of the Arkansas River from its mouth to Little Rock is about 2 ft, and from Little Rock to the mouth of the Verdigris River, about 1 ft.

2. The Arkansas River multipurpose project as presently authorized provides for improvement of the Arkansas River and its tributaries in Arkansas and Oklahoma by construction of coordinated developments to serve navigation, produce hydroelectric power, afford additional flood control, and provide related benefits such as public facilities for recreation and conservation of fish and wildlife.

3. The navigation feature of the project provides for a 9-ft-deep channel from Catoosa, Okla., on the Verdigris River, 52 miles downstream to the Arkansas River at mile 458, thence down the Arkansas River to Arkansas Post, about 46 miles above its mouth. From this point the Arkansas Post Canal will connect the Arkansas River with the White River; the navigation channel will then continue down the White River for about 10 miles to its junction with the Mississippi River. The 9-ft-deep channel will be provided by a system of locks and dams, some of which will be used

* A table of factors for converting British units of measurement to metric units is presented on page vii.

for both navigation and hydroelectric power production. Lock chambers will be 110 by 600 ft on the Arkansas River and in the canal connecting with the White River, and 83 by 600 ft on the Verdigris River. A minimum channel width of 150 ft is proposed for the Verdigris River section, 250 ft for the Arkansas and White River sections, and 300 ft in the Arkansas Post Canal. Bank stabilization and channel rectification works, such as training dikes, cutoffs, and revetments, are included in the multipurpose plan and are part of the proposed overall development of the Arkansas River.

Description of Structures and Improvements

4. Ozark Lock and Dam is one unit of the navigation portion of the multipurpose plan for the development of the Arkansas River and its tributaries in Arkansas and Oklahoma. The site of Ozark Lock and Dam will be at mile 308.9 (1940 survey), 1.4 miles downstream from the Highway 23 bridge crossing the Arkansas River at the city of Ozark and 0.8 miles upstream from the Arkansas Electric Cooperative Corporation steam generating plant. The lock and dam will be located on the left bank of the river in Franklin County; the reservoir will extend approximately 57.6 miles upstream and will be contained in Franklin, Crawford, and Sebastian Counties, Ark.

5. The structures, as planned, will consist of a single lock, a non-navigable, 890-ft-long dam, and a hydroelectric power plant in the right overbank (fig. 2). The lock will have a 110- by 600-ft lock chamber, 600-ft guard walls upstream and downstream on the river wall, and 60-ft guide walls on the land wall. The lock is designed for a lift of 34 ft with the upper pool at el 372* and the lower pool at el 338. The lock will have a maximum lift of 37 ft when the lower pool reaches el 335. The tops of the upper approach walls and the lock walls will be set at el 382, and the lower approach walls will be set at el 370. A paved parking esplanade at el 382 will be provided adjacent to the land wall extending from the upper lock gate to the operation building. The left bank access road will extend from the esplanade to U. S. Highway 46, and the

* All elevations (el) cited herein are in feet referred to mean sea level.

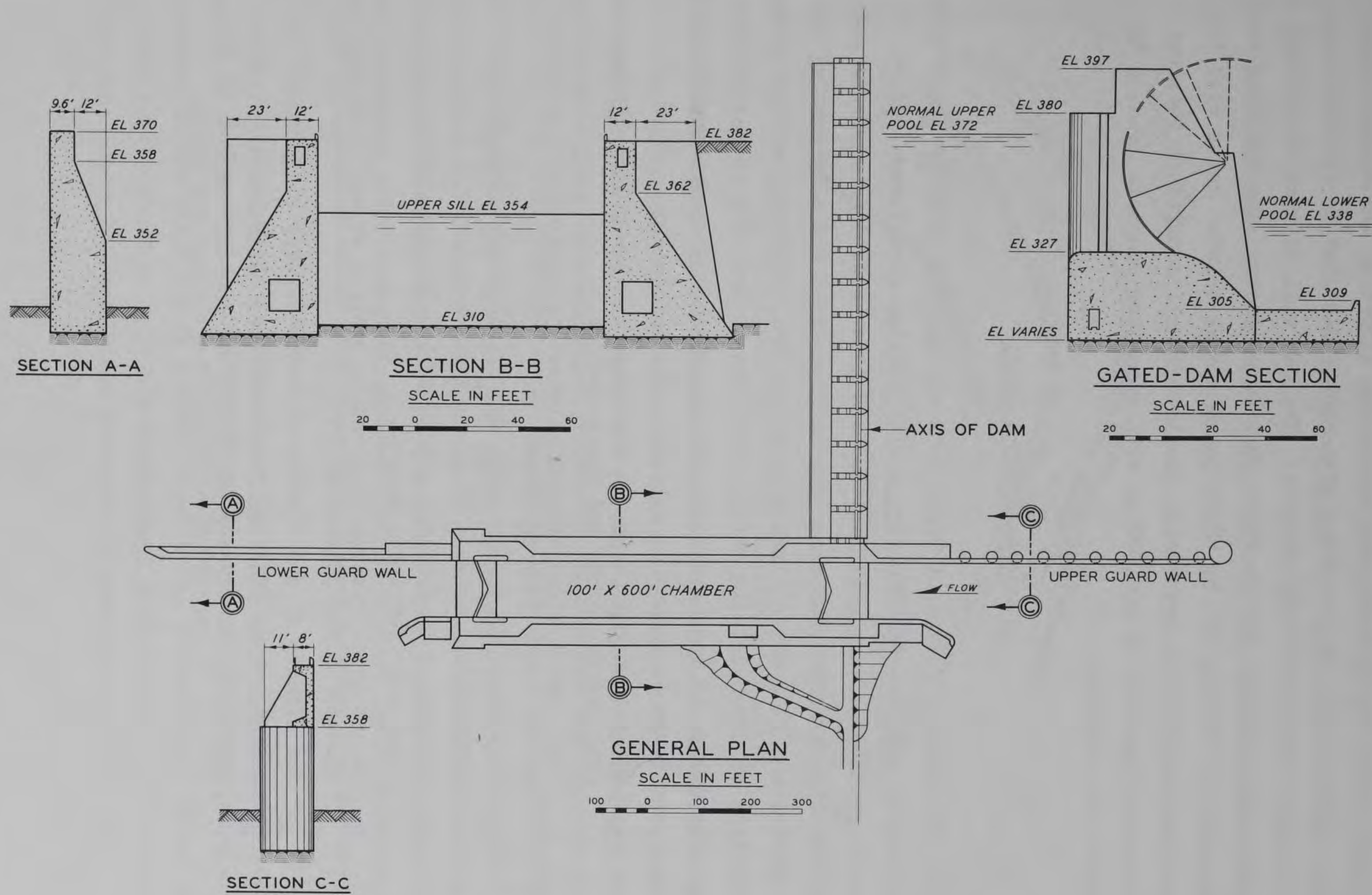

Fig. 2. General plan of lock and dam

right bank access road will extend from Arkansas State Highway 23 to the powerhouse area. The upstream and downstream slopes of the access roads and the esplanade will be protected with riprap designed to provide resistance to scour during overflow periods. The dam will consist of fifteen 50-ft-wide spillway bays and fourteen 10-ft-wide piers. The spillway will be controlled by fifteen 50- by 46-ft conventional tainter gates with the sills set at el 327. The powerhouse facilities will consist of four units with a station capacity of 100,000 kw with excavated channels leading to the headbay and tailrace.

Purpose of Model Study

6. The general design of Ozark Lock and Dam was based on sound theoretical design practice and experience with similar structures. Since navigation conditions vary with location and flow conditions upstream and downstream of a structure and since the configuration and alignment of the river channel and flow are not the same at any two locations, an analytical determination of the hydraulic effects that can be expected to result from a particular design is both difficult and uncertain. A comprehensive model study was considered necessary to determine the following:

- a. Navigation conditions in the upper and lower lock approaches with various plans and modifications.
- b. The effects of powerhouse releases on navigation conditions in the lower lock approach.
- c. Distribution of flow along the overbank and through the structures.
- d. Velocities at critical points in the vicinity of the structures and near spoil areas.
- e. Amount of excavation required to provide an efficient approach channel to the powerhouse.
- f. The effects of spoil areas on water-surface elevations.
- g. Modifications considered necessary or desirable to eliminate conditions that might be hazardous or objectionable to navigation or to improve flow conditions through the reach.

Description

7. The Ozark Lock and Dam model (fig. 3) was a scale reproduction

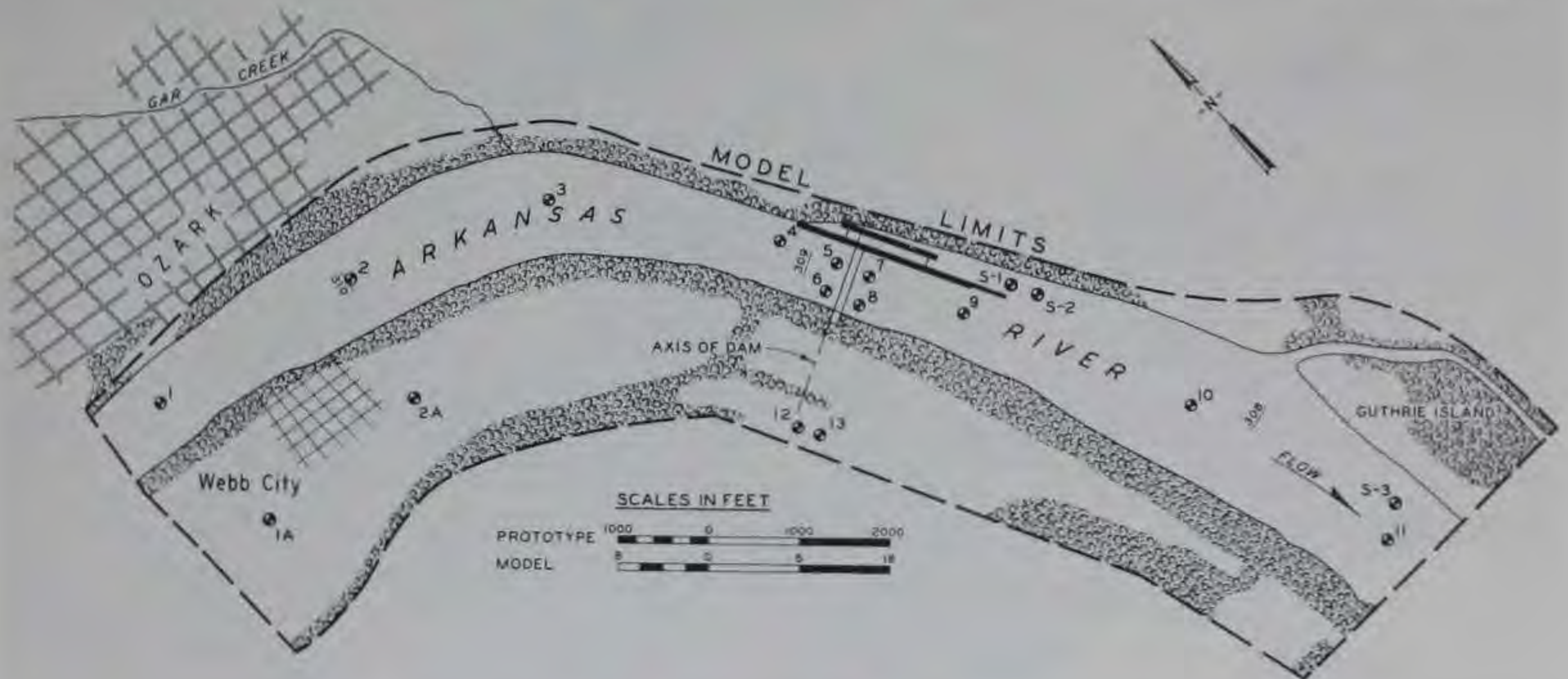

Fig. 3. Model layout and locations of gages

of a 2.7-mile reach of the Arkansas River, extending 1.3 miles above and 1.4 miles below the proposed site for the structures, mile 308.9 (1940 survey). The model was of the fixed-bed type, with the channel and over-bank areas molded in sand-cement mortar to sheet metal templates up to el 385 on the left bank and including sufficient area of the floodplain on the right bank for accurate reproduction of the flood flows (fig. 4). The model channel and overbank were molded to simulate conditions shown by a survey made in January-March 1963. The piers, lock, guide and guard walls, dam, spillway, and powerhouse were fabricated of sheet metal to prevent any change in elevation which might have been caused by expansion or warping after the structures were set.

8. Pile dikes were simulated in the model by a row of metal rods spaced to provide the desired permeability. The lock and dam gates were simulated schematically with simple, sheet metal slide gates. Water was supplied to the model by a 15-cfs centrifugal pump operating in a circulating water-supply system and was measured by means of a 10- by 5-in.



Fig. 4. The model

venturi meter for high flows and a 6- by 3-in. venturi meter for low flows. Water-surface elevations were measured by 13 piezometers (fig. 3) connected to a centrally located pit. Point gages or temporary gages were used as needed. Special electronic continuous recording gages were used to measure surges created in the lower lock approach by powerhouse releases.

9. A model tow and towboat (fig. 5) were used to determine the effects of currents on navigation passing under the Highway 23 bridge and approaching and leaving the locks. The towboat was propelled by a small electric motor operating from batteries located in the tow; the rudders and speed were remote-controlled. The power of the towboat was adjusted by means of a rheostat to provide for a maximum speed comparable to that of the towboats expected to use the Arkansas River.

Scale Relations

10. The model was built to an undistorted linear scale ratio of 1:120,

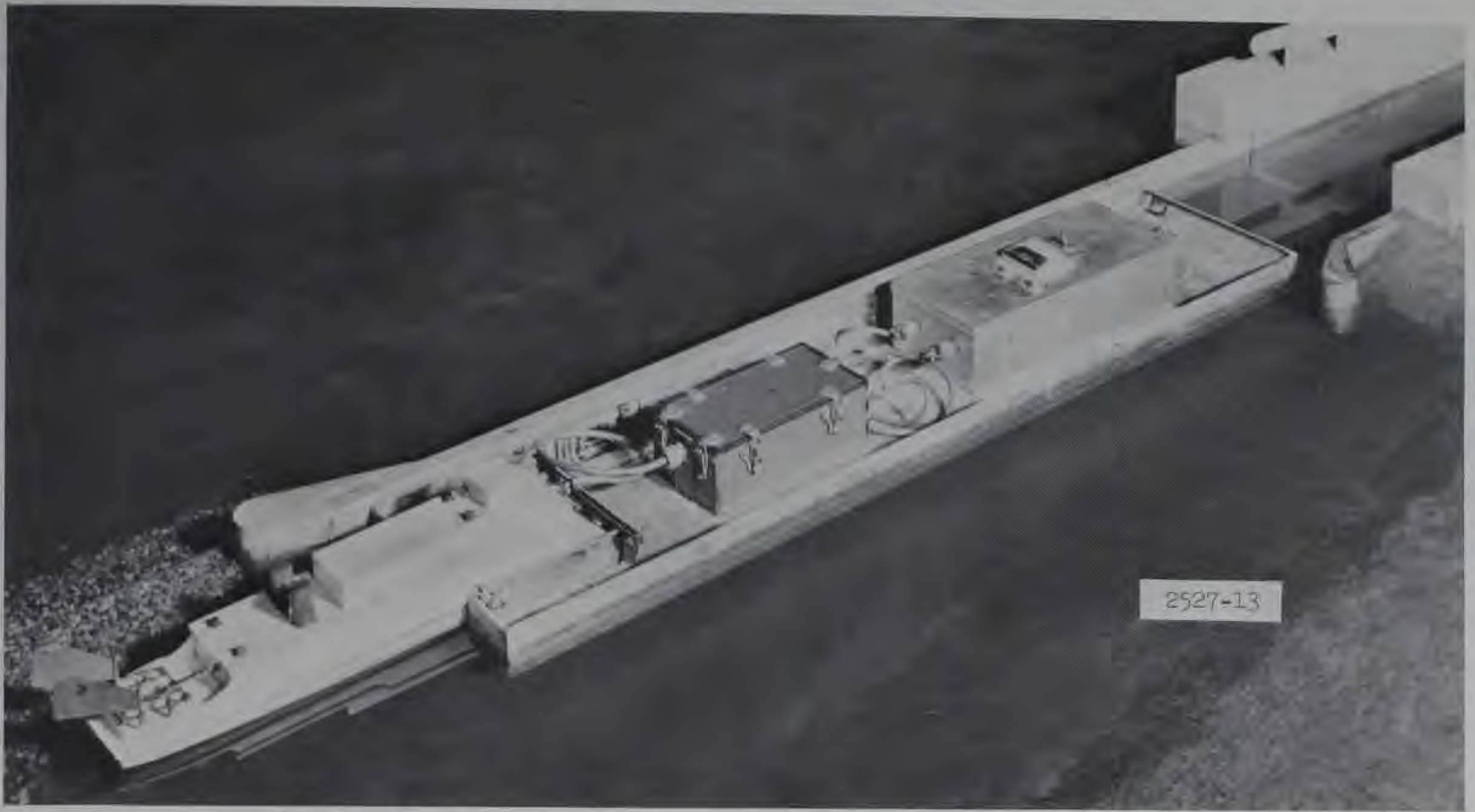

Fig. 5. Model tow and towboat

model to prototype, to effect an accurate reproduction of velocities, cross-currents, and eddies that would affect navigation. Other scale ratios resulting from the linear scale ratio were: area, 1:14,400; velocity and time, 1:10.95; discharge, 1:157,743; and roughness (Manning's n), 1:2.22. Measurements of discharge, water-surface elevation, and current directions and velocities can be transferred quantitatively from model to prototype equivalents by means of these scale relations.

Model Adjustment

11. The model was constructed, initially, to reproduce conditions in the prototype at the time the study was initiated, and roughness was adjusted until the model accurately reproduced the estimated prototype water-surface profiles furnished by the Little Rock District for flows ranging from 21,000 to 1,000,000 cfs. The model was constructed with a brushed cement-mortar finish to provide a roughness factor (Manning's n) of about 0.012, which corresponds to a prototype channel roughness of about 0.026. Additional roughness in the form of light stucco was required along the bottom and sides of the channel in some areas, resulting

in an average roughness over the channel area corresponding to a Manning's n of about 0.030. Check tests conducted after installation of the roughness indicated that the model closely reproduced the computed water-surface elevations.

12. The model was initially adjusted to reproduce, with a reasonable degree of accuracy, the estimated water-surface profiles for representative flows. After completion of the adjustment, the model was operated to obtain basic data for a number of flows ranging from 21,000 to 1,500,000 cfs. These data (table 1) were obtained to afford a basis for determining the effects of the lock and dam structures and other improvements on water-surface elevations.

PART III: TEST RESULTS

13. Tests on the model were concerned with the study of flow patterns, measurement of velocities in lock approaches, the behavior of the model tow on entering or leaving the locks with various river flows, the amount of swellhead, the amount of excavation required in the powerhouse approach channel, modifications of the approach channels, effects of spoil areas, and the distribution of flow in the model for various flows. No tests were conducted to determine the effects of dam gate operation other than with flow distributed uniformly over the entire length of dam.

Test Procedure

14. Tests were conducted reproducing stages and discharges which provided the following flow conditions: (a) controlled flows ranging from 21,000 to 500,000 cfs, inclusive, and (b) uncontrolled flows ranging from 600,000 to 1,500,000 cfs. The 500,000-cfs flow is the maximum flood of record modified by authorized reservoirs; the 600,000-cfs flow is the Standard Project Flood modified; and the 1,500,000-cfs flow is the maximum probable flood modified by reservoirs. The controlled river flows were reproduced by introducing the proper discharges, setting tailwater elevation for that discharge, and manipulating the dam gates until the required upper pool elevation was obtained. Uncontrolled river flows were reproduced by introducing the proper discharge with the dam gates fully open and manipulating the tailgate to obtain the proper tailwater elevation below the dam. All stages were permitted to stabilize before data were recorded.

15. Current directions were determined by plotting the paths of wooden floats with respect to ranges established for that purpose; floats were submerged to a depth of 9 ft, equivalent to the draft of a loaded barge. Velocities were measured by timing the travel of floats over known distances. Time-exposure photographs of the movement of the floats described above were used to measure velocities in the lower lock approach during power releases. General surface-current directions were determined from time-exposure photographs recording the movement of paper confetti

on the water surface. No data were obtained with the model tow other than observations of its behavior in the lock approaches with the different plans tested.

Plan A

Description

16. Plan A, which was the originally proposed design, included the following:

- a. A lock along the left bank with clear chamber dimensions of 110 by 600 ft with 600-ft-long upper and lower guard walls on the river-side lock wall and 60-ft-long guide walls on the land walls. The upper guard wall contained eleven 25-ft-wide ports with top elevation of 352. The bottom of the ports was the natural channel at an average elevation of 327. The tops of the upper approach walls and lock walls were set at el 382 and tops of the lower approach walls were set at el 370 (plate 1 and fig. 2).
- b. A dam, located at mile 308.9 (1940 survey), 890 ft long and containing fifteen 50-ft-wide by 46-ft-high tainter gates and fourteen 10-ft piers. All gate sills were at el 327.
- c. An esplanade and access road extending to the railroad, top el 382, placed along the left side of the lock. A 225-ft-long nonoverflow section, top el 382, extending along the right overbank from the powerhouse to high ground. A switchyard, top el 377, was placed downstream of the nonoverflow section.
- d. Powerhouse facilities consisting of a 394-ft-long powerhouse with four units having a capacity of 70,000 cfs and excavated entrance and exit channels.
- e. An upper lock approach channel dredged to el 357 along the alignment shown in plate 1.
- f. The riverbed was dredged to el 327 along the left bank in the approach to the dam and below the stilling basin.

Results

17. Results of the plan A tests are shown in tables 2-5. The average drop in water-surface elevation through the dam (between gages 5 and 6, and gages 7 and 8) during uncontrolled river flows (600,000 to 1,500,000 cfs) varied from about 2.0 to 3.3 ft (table 2). The increase in

water-surface elevation at gages 2 and 3 resulting from the installation of plan A varied from about 1.8 ft during the lower uncontrolled river flow (600,000 cfs) to about 3.3 and 3.0 ft for 1,000,000- and 1,500,000-cfs flows, respectively. The decrease in stages resulting from the removal of the right bank access road varied from about 0.1 ft for flows of 600,000 and 700,000 cfs to 0.4 and 0.5 ft for the higher flows (table 3).

18. With a flow of 1,500,000 cfs, measurements of velocities along the center line of the left and right bank access roads (plate 2) indicated velocities varying from about 7.3 to 9.6 and 7.3 to 15.5 fps (table 4) on the left and right bank, respectively.

19. Flow measurements with the 1,500,000-cfs discharge indicated that the left bank carried 5.9 percent of the flow, the spillway 80.7 percent, and the right overbank 13.4 percent, distributed as shown in table 5. Removal of the right bank access road decreased the left bank flow to 5.3 percent and the spillway to 79.0 percent, and increased the right bank flow to 15.7 percent.

20. The maximum flows with the upper pool elevations of 372 and 380 (gage 4) were 500,000 and 825,000 cfs, respectively (table 2). With the right bank access road removed, the maximum would increase to 510,000 and 840,000 cfs, respectively (table 3). All measurements were taken with all gates open.

Plan B

Description

21. Plan B included the upper lock approach channel and the lock and dam structures tested in plan A. Modifications for this plan were as follows:

- a. An increase in the size of the left bank esplanade and maintenance area as shown in plate 3.
- b. Removal of the powerhouse and modification of the right bank as shown in plate 3.
- c. Dredging of a lower lock approach channel to a bottom width of 300 ft and el 324, installation of a dike system along the right bank, and revetment along the left side of of the channel as shown in plate 4.

Results

22. Results of the plan B tests are shown in tables 6-8. The increase in water-surface elevation at gages 2 and 3 resulting from the installation of plan B varied from about 3.0 ft during the lower uncontrolled river flow (600,000 cfs) to about 4.0 to 4.3 ft with flows of 900,000 and 1,000,000 cfs, respectively, and 1.0 ft with a flow of 1,500,000 cfs (table 6). The average drop in water-surface elevation through the dam (gages 5 and 6 and gages 7 and 8) during uncontrolled river flows of 600,000 to 1,500,000 cfs varied from about 2.2 to 2.6 ft.

23. Measurements along the center line of the left and right bank access roads indicated maximum velocities over the left bank access road of about 3.0 fps with the 1,000,000-cfs flow and about 9.4 fps with the 1,500,000-cfs flow (table 7), and over the right bank road of about 9.2 to 14.1 fps with 900,000-cfs flow, 13.1 to 17.2 fps with 1,000,000-cfs flow, and 17.8 to 24.7 fps with 1,500,000-cfs flow. The distribution of flow along the axis of the dam is indicated below:

	Discharge, cfs			
	<u>640,000</u>	<u>900,000</u>	<u>1,000,000</u>	<u>1,500,000</u>
Left bank	--	Eddy	0.3%	3.8%
Spillway	99.0%	90.2%	87.6%	77.2%
Right bank	1.0%	9.8%	12.1%	19.0%

24. Discharges of 640,000 and 900,000 cfs were required to produce a depth of 1 ft on the right and left bank access roads, respectively. Discharges of 480,000 and 775,000 cfs produced upper pool elevations at gage 4 of 372 and 380, respectively (table 6).

Plan C

Description

25. Plan C was the same as plan B except for the following as shown in plate 5:

- a. A 575-ft-long powerhouse with a capacity of 100,000 kw and approach and exit channels was installed on the side of the dam.

- b. A switchyard and right bank access road as shown.
- c. The channel configuration downstream of the dam that was developed during preliminary tests and based on an evaluation of currents and velocities.

Results

26. Results of plan C indicated increases in water-surface elevations (at gages 2 and 3) resulting from the installation of plan C varied from about 2.2 ft during the lower uncontrolled river flow (600,000 cfs) to about 4.0 to 4.5 ft with flows of 900,000 and 1,000,000 cfs and 1.1 ft with the 1,500,000-cfs flow (table 9). The increases were about the same as those obtained with plan B except for the 600,000-cfs flow which was about 1.0 ft lower. The average drop in water-surface elevation through the dam (gages 5 and 6 and gages 7 and 8) during uncontrolled river flows varied from about 1.1 ft with the 600,000-cfs flow to 2.8 ft with the 1,500,000-cfs flow.

27. Discharges of 500,000 and 790,000 cfs were required to produce an upper elevation at gage 4 of 372 and 380, respectively.

Plan D

Description

28. Plan D was the same as plan C except for the following:
- a. Excavation along the left bank in the upper lock approach as shown in plate 6.
 - b. Reduction of the length of the powerhouse by 210 ft and orienting it parallel to the axis of the dam.
 - c. Modification of the powerhouse approach and exit channels and the placing of spoil along the right bank upstream and downstream of the dam as shown in plates 4 and 6.

Results

29. Results of tests of plan D are shown in plates 7-11 and table 10 and are discussed below.

30. Upper lock approach. Current directions and velocities with a total flow of 150,000 cfs (50,000 cfs through powerhouse) indicate that an eddy would form on the land side of the upper guard wall and extend

upstream about 800 ft from the end of the wall (plate 7). Currents upstream of the eddy would move riverward producing a set in the currents that would tend to move the head of a downbound tow riverward as speed is reduced for the approach to the lock. With no flow through the powerhouse, the alignment of currents with the 150,000-cfs discharge was improved and the size of the eddy in the lock approach was reduced (plate 8).

31. With the 300,000-cfs flow and the powerhouse in operation (50,000 cfs), the velocity of currents along the approach channel was considerably higher, varying generally from about 4.0 to 5.3 fps (plate 9). Also, the size of the eddy was considerably smaller than with the 150,000-cfs flow. With no powerhouse flow, conditions in the upper approach were somewhat better because of a reduction in velocities (plate 8). The size of the eddy in the lock approach was not affected appreciably by powerhouse flow. The alignment of currents and distribution of flow approaching the spillway, particularly along the right side, were better without flow through the powerhouse.

32. Because of the set of the currents, the head of the model tow tended to move riverward with both the 150,000- and 300,000-cfs flows. Attempting to flank into the approach by retarding the movement of the tow as it approached the guard wall increased the movement of the head of the tow riverward. This was attributed to the differences in depth along and within the approach channel.

33. Lower lock approach. Flow from the spillway moving toward the left bank downstream of the end of the lower guard wall produced currents that would prevent the head of a downbound tow from moving riverward (plates 10 and 11). With powerhouse flow and no flow through the spillway a large eddy would form downstream of the spillway, and most of the powerhouse flow would move directly across the river channel toward the left bank and across the lock approach channel (plate 10). The velocities of currents moving across the approach channel were 2.0 to 3.3 fps and would be sufficient to affect the movement of tows entering or leaving the locks.

34. The alignment of the currents in the lower approach was improved by a flow through the spillway. The size and intensity of the eddy formed in the lower approach would increase with an increase in spillway discharge.

Description

35. Plan E was the same as plan D except for the addition of submerged dikes, with top at el 357, in the upper lock approach channel as shown in plate 12. Plan E-1 was the same as plan E except that the ends of the dikes were extended to line up with the river side of the cell at the end of the guard wall instead of along the land side of the guard wall as in plan E. Plan E-2 was the same as plan E except that spoil was placed between the submerged dikes and along the approach channel as shown in plate 13.

36. The above plans were designed to overcome the detrimental effects on navigation of the irregular channel depths in the upper approach channel and to minimize the effects of crosscurrents in the lower lock approach channel.

Results

37. The results of tests of plan E indicate that the submerged dikes reduced the length and size of the eddy in the upper lock approach and improved the alignment of currents within the channel and along the left bank. Conditions were better with the longer dikes of plan E-1, but the difference was not appreciable. Placing spoil between the dikes and along the left bank eliminated some of the disturbance of flow caused by the dikes and produced better conditions for navigation than either of the other two plans (E and E-1). The tendency for the downbound tows to be moved riverward, noted in the test of plan D, was practically eliminated.

Plan F

Description

38. Plan F was concerned with the improvement of navigation conditions in the lower lock approach. The various schemes tested are outlined as follows:

Scheme 1 - A 400-ft extension, top el 340, was placed at the end of the lower guard wall (plate 14).

- Scheme 2 - Same as scheme 1 except that the top elevation was raised to 348.
- Scheme 3 - Same as scheme 1 except that the top elevation was raised to 352.
- Scheme 4 - Extension to the lower guard wall was removed and revetment along left bank was extended upstream as shown in plate 15. Top of the revetment was at el 350 (plate 15).
- Scheme 5 - Guard wall extension and extension of the left bank revetment were the same as in schemes 2 and 4 (plate 16).
- Scheme 6 - Same as scheme 5 except that the left bank revetment was extended farther upstream as shown in plate 16.
- Scheme 7 - Guard wall was extended with a stone dike with its crest at el 348 and dikes and revetment were modified as shown in plate 17.
- Scheme 8 - Same as scheme 7 except that the crests of the first three dikes (upstream) in the left bank dike system were raised above the water-surface elevation for 300,000-cfs flow.
- Scheme 9 - Same as scheme 8 except that the revetment upstream of the existing structures along the left bank was raised above the water-surface elevation for the 300,000-cfs flow.
- Scheme 10 - Same as scheme 6 except that guard wall extension was constructed of stone.

Results

39. The results of tests of plan F are shown in plates 14-17 and indicate the following:

- a. Extension of the lower guard wall, schemes 1-3, produced an improvement in the alignment of currents in the lower approach, particularly with a powerhouse flow and no flow through the spillway (plate 14). Conditions for navigation were better with the extension at the higher elevation. With the guard wall extension at el 340 (scheme 1) there would be flow over the wall that would tend to move the head of an upbound tow away from the wall. The effect of these currents would tend to increase with increases in flow.
- b. Extension of the upstream left bank revetment without the extension on the lower guard wall (scheme 4) had little effect on the alignment of currents moving across the lower approach channel with powerhouse flow, but produced

some improvement in the alignment of currents with the higher flows (plate 15).

- c. The upstream extension of the left bank revetment with extension of the lower guard wall (el 348), schemes 5-10, improved the alignment of currents in the lower lock approach (plates 16 and 17). Extension of the revetment upstream to tie in with the left bank opposite the end of the land-side lock wall (schemes 6 and 10) would reduce the size and intensity of the eddies in the lock approach but would adversely affect the direction of currents moving from the end of the guard wall extension toward the left bank revetment. Extending the left bank revetment upstream only as far as included in schemes 5, 7, 8, and 9 would improve the alignment of currents in the approach and would provide additional maneuvering area, particularly for down-bound tows attempting to move riverward after leaving the lock. Conditions were better with the revetment extension and dikes included in schemes 7 and 8 than with only the revetment extended upstream to tie in with the left bankline as in scheme 5. With the additional dikes and the revetment extension placed at a top elevation of 350, flows overtopping the revetment and dikes would produce currents that would be hazardous to navigation during the higher flows. This condition could be eliminated by raising the dikes and revetment above the elevation of the maximum navigable flow as in scheme 9. Even with scheme 9 there would be flow from the channel toward the left overbank farther downstream that could be hazardous to tows moving close along the revetment during high flows. Extension of the lower guard wall with a stone dike rather than with a concrete wall would have little effect on the results in the lower approach.

Plan G

Description

40. Plan G was concerned with the development of a satisfactory approach to the powerhouse. The modifications tested involved changes in the alignment of the right bank upstream of the powerhouse.

Results

41. The results of tests of this plan are shown in plate 18 and indicated that with the original design a large eddy would form along the right bank of the approach just upstream of the powerhouse which would affect flow into the powerhouse intake. A reduction in the excavation

along the right bank upstream of the powerhouse (modification 1) had only a small effect on the size of the eddy and the flow toward the powerhouse. The removal of the point in the bankline at the start of the transition (modification 2) appreciably reduced the size of the eddy and confined it mostly to the right slope. Flow conditions into the powerhouse intake were generally good and somewhat better than indicated by the direction of the currents shown in plate 18 since the eddy was mostly near the surface of the water in the approach channel. The distribution of flow through units 1 to 5 from left to right with a 50,000-cfs flow was 18.3, 20.8, 20.6, and 19.5 percent of the total. Observations indicated that the eddy along the right bank could not be completely eliminated without the use of a vertical or warped wall leading to the powerhouse from that side.

Powerhouse Release Studies

Description

42. Powerhouse release tests were conducted with a 400-ft extension of the lower guard wall and with a stone-fill revetment installed along a line extending from the mooring area landward of the lock to the existing left bank revetment downstream from the lock (plan F, scheme 6, plate 16) except for the tests shown in photographs 8 and 9 which were conducted with the stone-fill revetment ending about 200 ft downstream of the end of the guard wall and connected to the bank (plan F, scheme 8, plate 17).

43. Tests of powerhouse releases were conducted to determine the effects of changes in powerhouse flow on navigation in the lower lock approach and on water-surface elevations. A normal change in the powerhouse releases was considered to be an increase in discharge from 0 to 50,000 cfs or a decrease in discharge from 50,000 cfs to 0 in 25 min.

44. The rapid increase and decrease in powerhouse discharge were assumed to occur in about 6 sec (prototype). The direction of currents and current velocities were determined during these tests with time-exposure photographs and timed flashes.

45. Water-surface elevations at key gages were obtained with special automatic continuous-recording gages.

Results

46. Results of these tests (shown in photographs 1-9 and plate 19) with the model towboat indicate the following:

- a. Instantaneous releases of powerhouse flow, photographs 1-3, with no flow through the dam would cause a sudden movement of a tow standing in the lower approach downstream of the guard wall extension. The movement would be abrupt, as the wave hit the tow, but of short duration. After the initial impact, the tow would gradually move toward the bank. After the initial impact the effect on the movement of a tow under power would be small. It is believed that there should be some limitations placed on the powerhouse releases with no flow through the dam. Increasing powerhouse releases from 0 to 50,000 cfs during a period of not less than 10 min should be adequate. With substantial flow through the spillway, no limitations would be required.
- b. A sudden shutoff of powerhouse release (see photograph 8) with no flow through the spillway would produce a movement riverward of the head of an upbound tow waiting in the lower approach (the head about 200 ft downstream of the end of the guard wall extension). The movement would be substantial but not abrupt. The portion of the tow some distance downstream would not be affected, but the effect on the head of the tow would cause it to be rotated counter-clockwise. If the movement of the tow is not checked, the head would be moved riverward of the navigation channel. Any movement of a tow under power would tend to offset this effect.

47. The effects of changes in powerhouse releases on water-surface elevations are shown in plate 19. It should be noted that with a normal change in powerhouse release, the change in water-surface elevation is gradual but becomes abrupt with rapid changes in release. The results of these tests indicate that some limitations should be placed on the rate of change in powerhouse releases. It appears that the maximum change in powerhouse discharge should occur over a period of not less than 10 min when there is little or no spillway discharge. With substantial flow through the spillway no limitations are indicated.

Tests with Flood Flows

Description

48. Tests were conducted to determine conditions in the reach with

various flood flows and the effects of the right access road embankment and spoil areas on water-surface elevations.

Results

49. Results of tests with flood flows are shown in tables 11-13 and photographs 10-15. These results indicate that overtopping of the right bank upstream of the dam would start with a flow of about 615,000 cfs and overtopping of the right dam embankment would start with a flow of about 830,000 cfs. A flow of about 920,000 cfs would produce flows about 1 ft deep over the right embankment (crest el 382) and initial overtopping of the railroad along the left bank would occur with a flow of about 1,000,000 cfs.

Head on Lock Gate

50. Tests indicated the head differential on the lower lock gate during lock emptying to be as follows:

<u>Discharge, cfs</u>	<u>Head on Lower Lock Gate, ft</u>
50,000	-0.1*
100,000	0.3
150,000	0.4
200,000	0.5
250,000	0.6
300,000	0.5

51. Extension of the lower guard wall and variation in height of the extension up to el 348 had no measurable effect on the head differential on the lower lock gate.

* Water surface 0.1 ft higher outside lock than inside due to eddy in lower approach.

PART IV: DISCUSSION OF RESULTS AND CONCLUSIONS

Limitation of the Model

52. The analysis of the results of this investigation is based principally upon a study of current directions and velocities in the upper and lower lock approaches and the effects of these currents on the behavior of the model tow. The velocities were indicated by wooden floats submerged to a depth of 9 ft (prototype). In evaluating test results, it should be borne in mind that small changes in the direction of flow or in velocities were not necessarily changes produced by a change in plan, since several floats introduced at the same point under the same flow conditions may follow different paths or move at different velocities, or both, because of pulsating currents and eddies. Current directions shown in the plates and in some photographs were obtained with wooden floats and are indicative of currents that will affect tows. Surface currents shown in the photographs were indicated by the movement of confetti which was affected, to some extent, by surface tension.

53. The fixed-bed type model was not designed to simulate the movement of sediment in the prototype, and therefore could not naturally develop the changes in channel configurations and slopes which can be expected from changes in the regulating works. The changes in the model channel were based initially on estimated cross sections and were modified according to interpretations of changes in the flow conditions. Because of the small model scale, it was difficult to reproduce or to measure water-surface elevations with an accuracy greater than ± 0.1 ft (prototype). This factor should be considered when evaluating data involving water-surface elevations.

Conclusions

54. With the original design, navigation would experience considerable difficulty in approaching the lock from upstream because of the set of the currents moving toward the spillway and the effect on the movement

of a downbound tow of differences in the depth of the approach channel. Satisfactory navigation conditions could be obtained by the installation of submerged dikes or by submerged dikes and a fill between the dikes along the approach channel.

55. With the original design, flow from the spillway moving toward the left bank downstream of the lower guard wall would produce currents that could cause downbound tows leaving the locks considerable difficulty. With powerhouse flow and no flow through the spillway, a large eddy would form downstream of the spillway with a sufficient concentration of flow moving across the lower approach channel to adversely affect tows approaching or leaving the lock. Safe conditions for navigation in the lower lock approach could be obtained with a relatively short upstream extension of the left bank revetment and a 400-ft extension of the lower guard wall with crest at el 348. Using a stone dike instead of a concrete wall for the extension would have little effect on the results.

56. Excavation of the powerhouse entrance channel can be reduced and distribution of flow into the powerhouse improved by the realignment of the right upstream bank.

57. A sudden increase in powerhouse flow from none to maximum would produce conditions that could be hazardous to tows downstream of the lock; a gradual increase would have little effect on navigation.

58. The head on the lower lock gate during lock emptying would tend to be about 0.5 to 0.6 ft with discharges of about 200,000 cfs and above. Extension of the lower guard wall with the crest at el 348 or lower would have little or no effect on the head, particularly with the higher flows.

Table 1
Water-Surface Elevations, Adjustment Test

Gage No.*	Discharge in 1000 cfs												
	21	100	200	300	400	500	600	700	800	825	900	1000	1500
1	342.0	352.3	358.5	363.7	367.8	371.0	373.7	375.7	377.4	378.1	379.5	381.0	391.5
2	341.9	352.1	358.0	363.2	367.1	370.3	372.9	375.0	376.7	377.3	378.6	380.0	391.0
3	341.7	351.9	357.9	363.2	367.1	370.1	372.7	374.8	376.6	377.3	378.6	380.0	391.0
4	341.7	351.9	357.8	363.0	366.7	369.8	372.1	374.2	375.8	376.4	377.6	379.0	391.0
5	341.7	351.9	357.7	362.9	366.5	369.5	371.8	373.8	375.5	376.0	377.2	378.4	389.9
6	341.6	351.9	357.6	362.8	366.5	369.5	271.7	373.7	375.3	375.8	376.9	378.3	389.5
7	341.6	351.8	357.5	362.5	366.2	369.1	371.3	373.3	374.9	375.4	376.5	377.7	389.0
8	341.6	351.8	357.5	362.6	366.2	369.1	371.3	373.3	374.9	375.4	376.5	377.8	389.0
9	341.6	351.7	357.4	362.4	366.0	369.0	371.3	373.3	374.9	375.4	376.5	377.7	389.0
10	341.0**	351.0	356.5	361.5	365.1	368.0	370.3	372.2	374.0	374.4	375.5	376.8	388.4
11	--	350.6**	356.0**	361.0**	364.5**	367.4**	369.5**	371.5**	373.0**	373.7**	374.8**	376.0**	387.5**
12	--	--	--	--	--	--	--	377.5	378.4	378.8	379.2	379.6	389.0
13	--	--	--	--	--	--	--	377.4	378.4	378.8	379.1	379.6	389.0

Note: All elevations are in feet referred to mean sea level.

* Gage locations are shown in fig. 3.

** Control gage.

Table 2
Water-Surface Elevations, Plan A

Gage No.*	Discharge in 1000 cfs												
	21	100	200	300	400	500	600	700	800	825	900	1000	1500
1	372.0	372.1	372.1	372.2	372.4	372.6	375.3	377.7	380.3	381.0	382.5	384.2	394.1
2	372.0	372.0	372.0	372.0	372.0	372.1	374.7	377.1	379.5	380.2	381.6	383.4	393.9
3	372.0	372.0	372.0	372.0	372.0	372.0	374.6	377.0	379.4	380.1	381.5	383.3	393.9
4	372.0**	372.0**	372.0**	372.0**	372.0**	372.0	374.6	376.9	379.3	380.0	381.2	382.9	393.5
5	372.0	372.0	371.9	371.9	371.8	371.6	374.1	376.2	378.4	379.0	380.4	382.0	392.4
6	372.0	372.0	371.8	371.5	371.3	370.9	373.2	375.2	377.3	377.9	379.1	380.6	391.2
7	341.8	351.6	357.4	362.5	366.2	369.4	371.7	373.5	375.3	375.8	376.8	378.0	388.5
8	341.8	351.6	357.4	362.6	366.2	369.4	371.6	373.4	375.1	375.7	376.7	377.9	388.6
9	341.8	351.6	357.4	362.5	366.0	368.9	371.1	373.0	374.9	375.3	376.4	377.6	388.4
10	341.0**	350.9	356.5	361.4	365.1	368.0	370.2	372.2	374.0	374.4	375.5	376.8	388.3
11	--	350.5**	356.0**	361.0**	364.5**	367.4**	369.5**	371.5**	373.1**	373.7**	374.8**	376.0**	387.5**
12	--	--	--	--	--	376.6	379.6	381.0	382.0	382.2	382.6	383.5	391.9
13	--	--	--	372.5	373.1	373.8	375.1	376.5	377.5	377.6	377.9	378.8	389.2

Note: All elevations are in feet referred to mean sea level.

* Gage locations are shown in fig. 3.

** Control gage.

Table 3

Water-Surface Elevations, Plan A, Without Access Road

Gage No.*	Discharge in 1000 cfs											
	300	400	500	510	600	700	800	825	840	900	1000	1500
1	372.2	372.4	372.5	372.7	375.2	377.5	379.8	380.5	380.9	382.0	383.9	393.7
2	372.0	372.0	372.0	372.7	374.6	377.0	379.2	379.7	380.2	381.1	383.0	393.5
3	372.0	372.0	372.0	372.0	374.5	377.0	379.2	379.7	380.1	381.1	382.9	393.5
4	372.0**	372.0**	372.0**	372.0	374.5	376.9	379.0	379.6	380.0	380.9	382.8	393.1
5	371.9	371.8	371.6	371.6	374.0	376.3	378.3	378.9	379.2	380.2	382.0	392.2
6	371.5	371.3	370.9	371.0	373.1	375.3	377.3	377.8	378.2	379.1	380.7	391.0
7	362.5	366.1	369.4	369.8	371.7	373.7	375.5	376.1	376.3	377.0	378.5	388.5
8	362.6	366.2	369.4	369.8	371.7	373.5	375.4	375.9	376.1	376.8	378.4	388.4
9	362.5	365.9	368.8	369.2	371.1	373.1	375.0	375.4	375.6	376.4	378.0	388.6
10	361.4	365.1	368.1	368.5	370.3	372.2	374.0	374.4	374.7	375.5	377.0	388.3
11	361.0**	364.5**	367.4**	367.8**	369.5**	371.4**	373.1**	373.6**	373.8**	374.8**	376.0**	387.5**
12	Dry	Dry	Dry	375.2	377.4	378.4	378.8	378.8	379.0	379.1	378.9	390.3
13	372.5	372.9	375.0	375.2	377.6	378.7	379.3	379.4	379.5	379.8	380.5	390.2
A	--	--	--	--	--	377.1	379.2	380.3	380.2	381.4	383.2	393.8
B	--	--	--	--	--	376.9	379.2	379.7	380.0	381.0	383.0	393.5
C	--	--	--	--	--	--	374.2	374.8	375.0	375.7	377.2	386.0

Note: All elevations are in feet referred to mean sea level.

* Gage locations are shown in fig. 3.

** Control gage.

Table 4
Velocities Along Center Line of Embankment, Plan A
 River Discharge 1,500,000 cfs

<u>Station*</u>	<u>With Access Road</u>	<u>Without Access Road</u>
	<u>Left Embankment</u>	
0+50	7.3	6.6
1+50	8.6	7.8
2+50	9.6	8.7
	<u>Right Embankment</u>	
0+50	7.3	
1+72	8.6	
3+27	15.5	
4+50	15.5	
5+50	13.9	
6+50	13.4	
7+50	14.5	
8+38	12.8	

Note: Velocities are in feet per second.

* Station locations are shown in plate 2.

Table 5
Distribution of Flow in cfs Prototype,* Plan A
 River Discharge 1,500,000 cfs

<u>Station**</u>	<u>With Access Road</u>		<u>Without Access Road</u>	
	<u>Discharge</u>	<u>Area, sq ft</u>	<u>Discharge</u>	<u>Area, sq ft</u>
		<u>Left Bank</u>		
0+00- 2+72	45,290	7,380	41,230	7,260
2+72- 4+55	42,850	7,960	38,360	7,950
		<u>Spillway</u>		
Gate 1 (left)	76,320		77,710	
2	82,040		82,720	
3	84,940		81,930	
4	82,510		82,060	
5	82,380		79,490	
6	85,080		80,190	
7	82,310		78,980	
8	82,190		78,920	
9	80,350		78,650	
10	81,450		78,790	
11	80,990		79,250	
12	77,100		77,760	
13	78,110		76,970	
14	78,230		76,540	
Gate 15 (right)	76,220		74,870	
		<u>Right Bank</u>		
0+00- 2+30	22,860	2,370	17,540	2,000
2+30- 8+90	178,780	14,940	218,040	13,800

* Measurements were made 60 ft upstream of center line of roadways on both banks.

** Station locations are shown in plate 2.

Table 6
Water-Surface Elevations, Plan B

Gage No.	Discharge in 1000 cfs								
	200	400	480	600	640*	775	900**	1000	1500
1	372.1	372.3	372.5	376.4	377.3	380.5	383.2	384.9	392.1
2	372.0	372.0	372.1	375.9	377.0	380.2	382.6	384.3	391.9
3	372.0	372.0	372.0	375.8	376.9	380.2	382.5	384.2	391.9
4	372.0+	372.0+	372.0	375.8	376.8	380.0	382.4	384.1	391.5
5	372.0	371.9	371.6	375.4	376.3	379.3	381.7	383.3	391.0
6	371.8	371.4	371.1	374.6	375.6	378.6	381.0	382.4	390.0
7	356.2+	367.3+	369.7+	372.8+	373.7+	376.5+	378.7+	380.3+	387.7+
8	356.2+	367.3+	369.7+	372.8+	373.7+	376.5+	378.7+	380.3+	387.7+
9	356.1	367.2	369.6	372.7	373.6	376.3	378.6	380.1	387.6
10	355.4	366.9	369.3	372.4	373.2	376.0	378.2	379.8	387.3
11	355.0	366.6	369.9	372.0	372.9	375.6	377.7	379.1	386.5
12	--	--	--	--	377.1	379.7	381.9	383.3	389.9
13	--	--	--	--	373.7	377.4	379.6	381.0	388.5
A	--	--	--	--	377.0	380.0	382.8	384.7	392.2
B	--	--	--	--	377.0	380.5	382.8	384.7	392.0
C	--	--	--	--	372.6	375.9	378.0	379.7	388.2

Note: All elevations are in feet referred to mean sea level.

* Flow 1 ft deep over right embankment.

** Flow 1 ft deep over left embankment.

+ Control gage.

Table 7
Velocities Along Center Line of Roadway, Plan B

<u>Station*</u>	<u>Discharge in 1000 cfs</u>		
	<u>900</u>	<u>1000</u>	<u>1500</u>
	<u>Left Bank</u>		
0+50	Eddy	3.0	6.8
1+50	Eddy	3.0	6.9
2+50	Eddy	2.2	9.4
	<u>Right Bank</u>		
0+50	12.5	16.0	22.6
1+50	14.1	16.0	24.7
2+50	14.1	16.0	24.7
3+50	10.9	14.8	17.8
4+50	10.9	13.1	17.8
5+50	12.5	16.0	21.4
6+50	12.5	16.0	22.6
7+50	11.0	15.8	19.0
8+50	9.2	16.0	22.6
9+50	12.5	16.0	21.4
10+50	12.5	17.2	23.6
11+50	12.5	16.0	22.6
12+70	13.0	16.0	19.1

Note: Velocities are in feet per second.
 * Stations are shown in plate 3.

Table 8
Distribution of Flow, Plan B

<u>Station*</u>	<u>Discharge in 1000 cfs</u>			
	<u>640</u>	<u>900</u>	<u>1000</u>	<u>1500</u>
	<u>Left Bank</u>			
0+00-2+72	No overtopping	Eddy	1,630	36,240
2+72-4+55	No overtopping	Eddy	1,030	20,640
	<u>Spillway</u>			
Gate 1 (Left)	41,150	48,870	56,290	77,900
2	45,460	54,610	60,160	80,710
3	45,510	56,910	62,280	82,360
4	45,940	57,910	62,340	82,940
5	44,870	58,090	60,110	82,040
6	45,010	56,210	58,870	80,230
7	45,070	57,110	58,650	80,300
8	43,210	54,940	57,260	80,300
9	43,890	53,440	59,150	75,110
10	42,310	54,830	58,710	76,560
11	39,280	54,960	57,910	74,820
12	39,690	54,010	57,910	73,210
13	38,260	52,250	57,110	70,220
14	38,980	53,280	57,250	69,850
15 (Right)	34,900	44,770	52,440	71,350
	<u>Right Bank</u>			
0+00-5+00	1,080	37,380	51,490	98,050
5+00-13+40	5,390	50,430	69,410	187,170

Note: Station 0+00 left bank is model limit.
 Station 0+00 right bank is right end of spillway.
 * Stations are shown in plate 3.

Table 9
Water-Surface Elevations, Plan C

Gage No. *	Discharge in 1000 cfs											
	200	300	400	500	520	600	640	790	830	900	1000	1500
<u>Present Tailwater Curve</u>												
1	372.2	372.0	372.3		372.6	374.5	375.8		380.9	382.3	384.5	391.4
2	372.1	372.0	372.1		372.1	374.0	375.2		380.4	381.6	383.8	390.9
3	372.0	372.0	372.0		372.0	374.0	375.1		380.4	381.5	383.7	390.9
4	372.0**	372.0**	372.0**		372.0	373.9	375.1		380.0	381.5	383.5	390.6
5	372.0	371.9	371.8		371.6	373.4	374.5		379.1	380.4	382.4	389.5
6	371.9	371.5	371.1		270.9	372.4	373.6		378.3	379.5	381.4	388.7
7	358.9**	363.7**	367.3**		370.2**	371.7**	372.7**		376.2**	377.4**	379.2**	386.5**
8	358.9**	363.7**	367.3**		370.2**	371.7**	372.7**		376.2**	377.4**	379.2**	386.5**
9	359.0	363.0	366.1		368.5	369.7	371.0		373.8	375.4	377.4	384.7
10	358.7	362.5	365.8		368.2	368.7	369.8		373.1	374.9	376.8	384.5
11	358.2	362.0	365.2		367.4	367.6	368.8		372.0	373.5	375.6	384.1
12	--	--	--		--	--	--		380.0	381.2	382.8	389.6
13	--	--	--		--	--	--		375.9	377.0	379.0	386.4
<u>Future Tailwater Curve</u>												
1	372.0	372.1	372.3	372.6		375.6	376.5	380.5		383.1	385.0	392.3
2	372.0	372.0	372.1	372.0		375.0	376.1	380.0		382.6	384.6	392.1
3	372.0	372.0	372.0	372.0		375.0	376.0	380.0		382.6	384.5	392.1
4	372.0**	372.0**	372.0**	372.0		374.9	376.0	380.0		382.4	384.3	392.0
5	371.9	372.0	371.8	371.6		374.3	375.5	379.0		381.3	383.2	391.0
6	371.8	371.5	371.1	371.0		373.5	374.5	378.1		380.4	382.2	390.0
7	356.2**	362.8**	367.3**	370.4**		372.8**	373.7**	376.7**		378.7**	380.3**	387.7**
8	356.2**	362.8**	367.3**	370.4**		372.8**	373.7**	376.7**		378.7**	380.3**	387.7**
9	356.2	362.1	366.1	368.9		371.2	371.5	375.1		376.9	378.3	386.9
10	355.7	362.1	365.8	368.7		370.2	371.1	374.3		376.2	377.9	386.5
11	354.9	361.0	365.2	368.0		369.5	370.2	373.2		375.5	377.3	386.1
12	--	--	--	--		--	376.6	379.7		381.9	383.5	390.5
13	--	--	--	--		--	--	376.1		378.3	380.0	388.5

Note: All elevations are in feet referred to mean sea level.

* Gage locations are shown in fig. 3.

** Control gage.

Table 10
Water-Surface Elevations,* Plan D

Gage No. **	Discharge in 1000 cfs					
	50	100	150	200	250	300
1	372.0	372.0	372.1	372.2	372.1	372.2
2	372.0	372.0	372.0	372.0	372.0	372.0
3	372.0	372.0	372.0	372.0	372.0	372.0
4	372.0†	372.0†	372.0†	372.0†	372.0†	372.0†
5	372.0	372.0	372.0	372.0	372.0	372.0
6	372.0	372.0	371.9	371.9	371.8	371.7
7	346.2†	351.7†	355.8†	358.9†	361.5†	363.9
8	346.2†	351.7†	355.8†	358.9†	361.5†	363.5
9	346.7	351.6	355.7	358.5	361.0	363.2
10	346.5	351.3	355.4	358.1	360.5	362.7
11	346.3	350.9	354.8	357.6	360.0	362.3
12	--	--	--	--	--	--
13	--	--	--	359.0	361.6	363.9

Note: All elevations are in feet referred to mean sea level.

* Water-surface elevations obtained with 50,000-cfs discharges through powerhouse.

** Gage locations are shown in fig. 3.

† Control gages.

Table 11

Flood Tests with Right Access Road Embankment in Place

Gage No.*	Discharge in 1000 cfs										
	615	625	800	830	850	920	1000	1000**	1200	1200**	1500
	Water-Surface Elevations, ft msl										
1	376.3	376.6	381.1	381.9	382.4	384.2	385.9	385.9	389.1	389.9	392.7
2	375.7	376.0	380.6	381.3	381.8	383.9	385.6	385.6	388.8	389.6	392.5
3	375.6	375.9	380.6	381.2	381.7	383.8	385.5	385.5	388.8	389.6	392.4
4	375.6	375.8	380.2	381.0	381.4	383.1	384.9	384.9	388.3	389.0	392.0
5	375.0	375.2	379.5	380.1	380.5	382.3	383.9	383.9	387.2	388.2	391.2
6	374.2	374.5	378.6	379.2	379.6	381.3	382.8	382.8	386.1	387.2	390.1
7	373.4+	373.8+	377.5+	378.2+	378.6+	380.1+	381.5+	381.5+	384.6+	384.6+	388.8+
8	373.0+	373.2+	376.9+	377.4+	377.8+	379.2+	380.5+	380.5+	383.8+	383.8+	388.0+
9	371.6	371.7	375.5	376.1	376.3	378.0	379.2	379.2	382.0	382.1	386.3
10	370.9	371.1	374.8	375.5	375.7	377.3	378.5	378.5	381.4	381.4	385.2
11	370.6	370.7	374.5	375.0	375.3	376.8	378.0	378.1	381.0	381.0	384.8
12	376.3	377.6	381.6	382.1	382.4	384.0	385.5	385.5	388.9	389.2	391.7
13	373.0	373.1	377.1	377.6	378.1	379.3	380.7	380.7	383.6	383.6	387.9
A	375.6	376.0	380.9	381.4	381.7	383.3	385.1	--	388.5	--	392.4
B	375.5	376.0	380.6	381.0	381.4	383.1	384.7	--	388.5	--	392.3
C	376.2	377.7	381.6	382.2	382.4	383.8	385.4	--	388.9	--	392.4
D	375.8	376.2	381.0	381.4	381.9	383.4	385.4	--	389.0	--	--
E	375.4	375.9	380.2	380.8	381.1	382.7	384.3	--	388.1	--	--
F	375.6	376.1	380.4	381.0	381.3	383.0	384.6	--	388.1	--	--
G	Dry	Dry	Dry	Dry	382.3	383.6	385.3	--	388.1	--	--
H	376.3	377.7	381.6	382.1	382.4	383.8	385.5	--	388.7	--	--
I	Dry	Dry	Dry	Dry	Dry	383.4	385.5	385.5	388.8	389.5	392.5
J	375.0	375.3	379.6	380.2	380.5	382.1	383.8	383.9	387.6	388.7	391.7
K	374.9	375.4	379.6	380.2	380.5	381.9	383.7	383.9	387.6	388.4	390.6
L	375.6	376.0	381.0	381.1	381.3	383.0	385.1	385.0	388.5	389.4	391.6
M	Dry	Dry	Dry	Dry	Dry	383.9	385.3	385.3	388.8	389.1	--
N	376.3	377.7	381.7	382.1	382.4	383.9	385.4	385.5	388.9	389.2	391.8
O	Dry	Dry	Dry	Dry	Dry	383.5	385.0	--	387.6	--	--
P	Dry	Dry	Dry	Dry	Dry	383.3	384.6	--	386.0	--	--
Q	Dry	Dry	Dry	Dry	382.4	383.1	384.2	--	385.7	--	--
R	Dry	Dry	Dry	Dry	Dry	Dry	Dry	--	384.0	--	--
S	Dry	Dry	375.5	376.1	376.3	377.6	378.9	--	381.1	--	--
T	Dry	Dry	Dry	Dry	Dry	383.9	385.0	--	387.4	--	--
U	Dry	Dry	377.3	377.6	377.6	378.8	380.1	--	383.7	--	--
V	Dry	Dry	Dry	Dry	Dry	Dry	Dry	--	382.2	--	--
W	371.4	371.5	375.4	376.0	376.1	377.6	378.5	--	382.3	--	387.4
X	373.4	373.6	377.8	378.1	378.2	379.4	380.9	--	384.5	--	388.4
Y	372.9	373.0	377.2	377.5	377.7	379.0	380.4	--	383.7	--	387.6
Z	Dry	Dry	377.2	377.6	377.8	379.2	380.4	--	383.7	--	387.9
A'	373.0	373.1	377.0	377.6	378.0	379.4	380.5	--	383.7	--	387.8
B'	371.4	371.6	375.5	375.9	376.1	377.6	378.5	--	381.7	--	--
C'	371.4	371.5	375.1	375.7	376.0	377.3	378.4	--	381.7	--	386.1
D'	372.5	372.8	376.9	377.0	377.6	378.9	380.2	--	383.1	--	387.1
E'	372.9	373.1	377.1	377.8	378.1	379.4	380.6	--	383.7	--	388.2
	Velocities, fps										
F'	--	4.2	6.2	5.6	6.3	5.8	5.5	--	4.2	--	5.0††
G	--	--	--	--	‡	‡	3.3	--	5.1	--	--
H	--	--	--	--	--	--	--	--	--	--	4.4
O	--	--	--	--	‡	Too shallow	3.6	--	9.1	--	--
P	--	--	--	--	‡	‡	Too shallow	--	13.2	--	15.7
Q	--	--	--	--	‡	Too shallow	6.6	--	13.2	--	--
T	--	--	--	--	‡	‡	5.5	--	9.1	--	--
U	--	--	‡	‡	‡	‡	3.3	--	5.2	--	--
Z	--	--	‡	‡	1.4	‡	1.5	--	‡	--	11.4

* Gage locations are shown in fig. 3 and plate 6.

** Elevations obtained with spillway gates set at el 380.

+ Control gages.

†† Flow from overbank toward river.

‡ Velocity erratic and less than 1 fps.

Table 12

Embankment Tests, Right Bank Access Road Removed, Plan D

Gage No.*	Discharge in 1000 cfs						
	625	800	850	1000	1200	1200**	1500
	<u>Water-Surface Elevations, ft msl</u>						
1	376.6	380.9	382.0	385.5	388.9	389.6	392.2
1A	375.5	--	381.5	--	--	--	--
2	376.0	380.3	381.6	385.0	388.6	389.4	391.9
2A	373.4	--	380.9	--	--	--	--
3	376.0	380.3	381.5	384.9	388.5	389.4	391.9
4	375.8	380.2	381.4	384.7	388.1	388.9	391.4
5	373.3	379.4	380.6	383.9	387.3	388.3	390.9
6	374.6	378.5	379.8	383.0	386.4	387.3	390.0
7	373.8	377.6†	378.7	381.9	385.3	385.4	389.0
8	373.2	376.8†	378.2	381.3	384.6	384.7	388.4
9	371.9	375.5	376.6	379.6	382.9	382.9	386.8
10	371.2	374.8	375.7	378.5	381.4	381.3	385.9
11	370.7†	374.4†	375.4†	378.1†	381.1†	381.1†	384.8†
12	373.4	377.5	379.1	381.9	385.5	386.3	389.8
13	373.4	377.4	378.8	381.7	384.9	385.3	389.1
A	376.1	--	381.5	--	--	--	--
B	375.7	--	381.2	384.4	388.1	--	391.6
C	373.2	--	380.7	384.3	388.2	--	391.5
G	--	--	--	--	--	--	391.3
H	--	--	--	--	--	--	391.3
I	--	--	--	385.5	388.4	389.4	--
J	--	379.2	--	383.7	387.3	388.4	--
K	--	379.4	--	383.6	387.1	387.6	--
L	--	381.0	--	383.8	387.9	388.9	--
M	--	--	--	384.0	386.2	387.1	--
N	--	377.6	--	381.8	385.6	386.5	389.7
A'	--	--	--	381.2	384.8	--	--
E'	--	--	--	380.8	384.5	--	--
	<u>Velocities, fps</u>						
E'				10.5	9.9		8.8
F'				3.4††	2.7‡		3.4‡
G				Too slow	3.8		5.8
H				9.6	5.8		6.1

Note: Control elevation at gage 11 was based on test with roadway in place (table 11).

* Gage locations are shown in fig. 3 and plate 6.

** Elevations obtained with spillway gates set at el 380.0.

† Control gages.

†† Flow from river toward overbank.

‡ Flow from overbank toward river.

Table 13

Embankment Tests, Spoil Downstream of Dam Removed, Plan D

Gage No.*	Discharge in 1000 cfs		
	920	1000	1200
1	383.9	385.7	388.7
2	383.4	385.2	388.5
3	383.3	385.1	388.5
4	382.8	384.5	387.7
5	382.0	383.6	386.7
6	381.0	382.4	385.5
7	379.7	381.0	384.1
8	378.8	380.0	383.1
9	377.6	378.9	381.8
10	377.4	378.7	381.8
11	376.8**	378.0**	381.1**
12	383.7	385.2	388.0
13	378.7	379.9	382.7
I	383.4	384.9	388.1
J	382.0	383.4	387.0
K	382.0	383.7	386.3
L	382.9	384.4	387.7
M	383.8	385.0	387.9
N	383.7	385.0	388.1

Note: Control elevations at gage 11 were based on tests with roadway and spoil in place (table 11). All elevations are in feet referred to mean sea level.

* Gage locations are shown in fig. 3 and plate 6.

** Control gages.

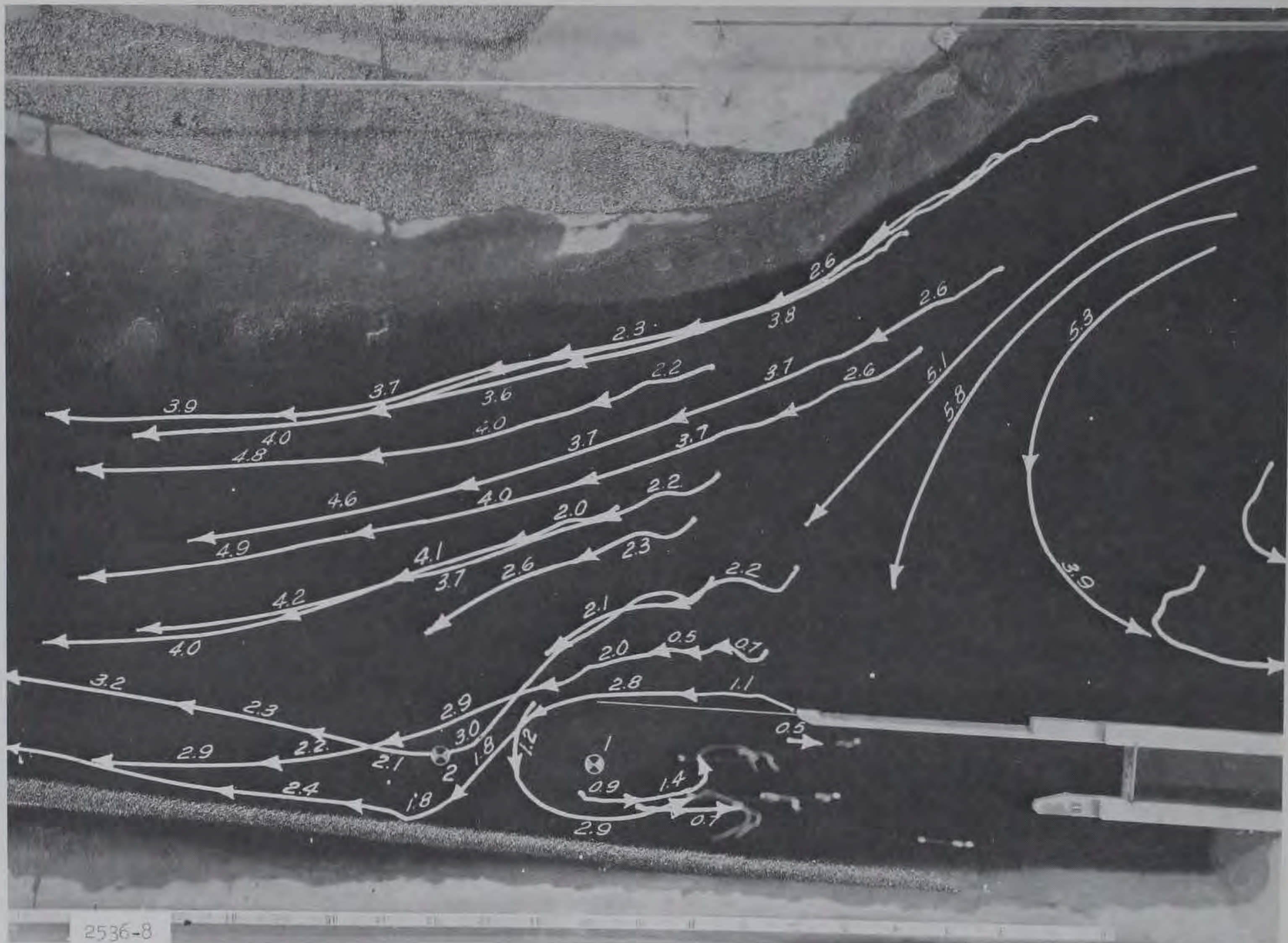

Photograph 1. Paths of floats (submerged 9 ft) during period 0-11 min after start of powerhouse release. Powerhouse discharge increased from 0 to 50,000 cfs in 6 sec (prototype). Numbers indicate average velocity in feet per second during 11-min period

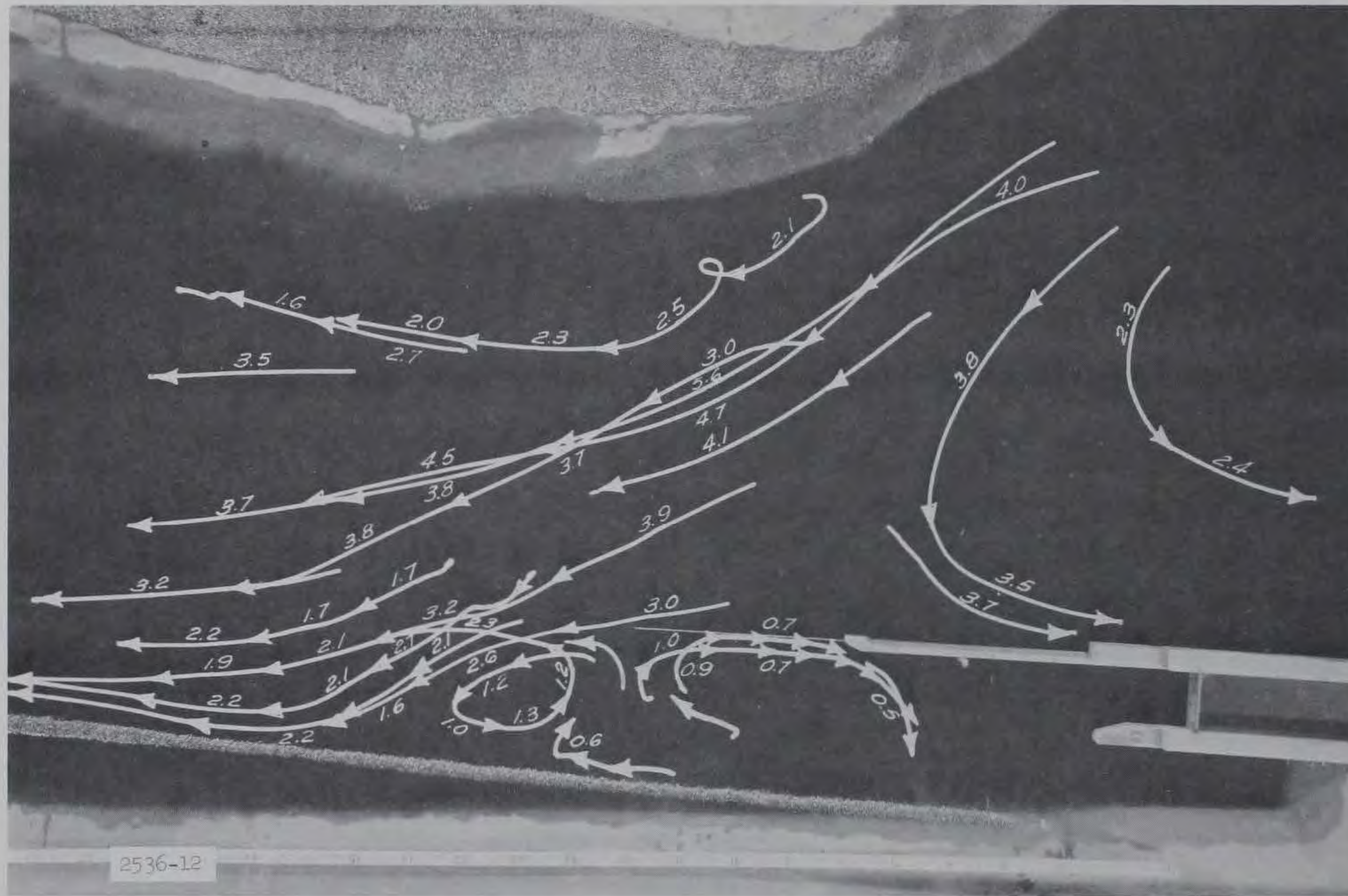

Photograph 2. Paths of floats (submerged 9 ft) during period 22-33 min after start of powerhouse release. Powerhouse discharge increased from 0 to 50,000 cfs in 6 sec (prototype). Numbers indicate average velocity in feet per second during 11-min period

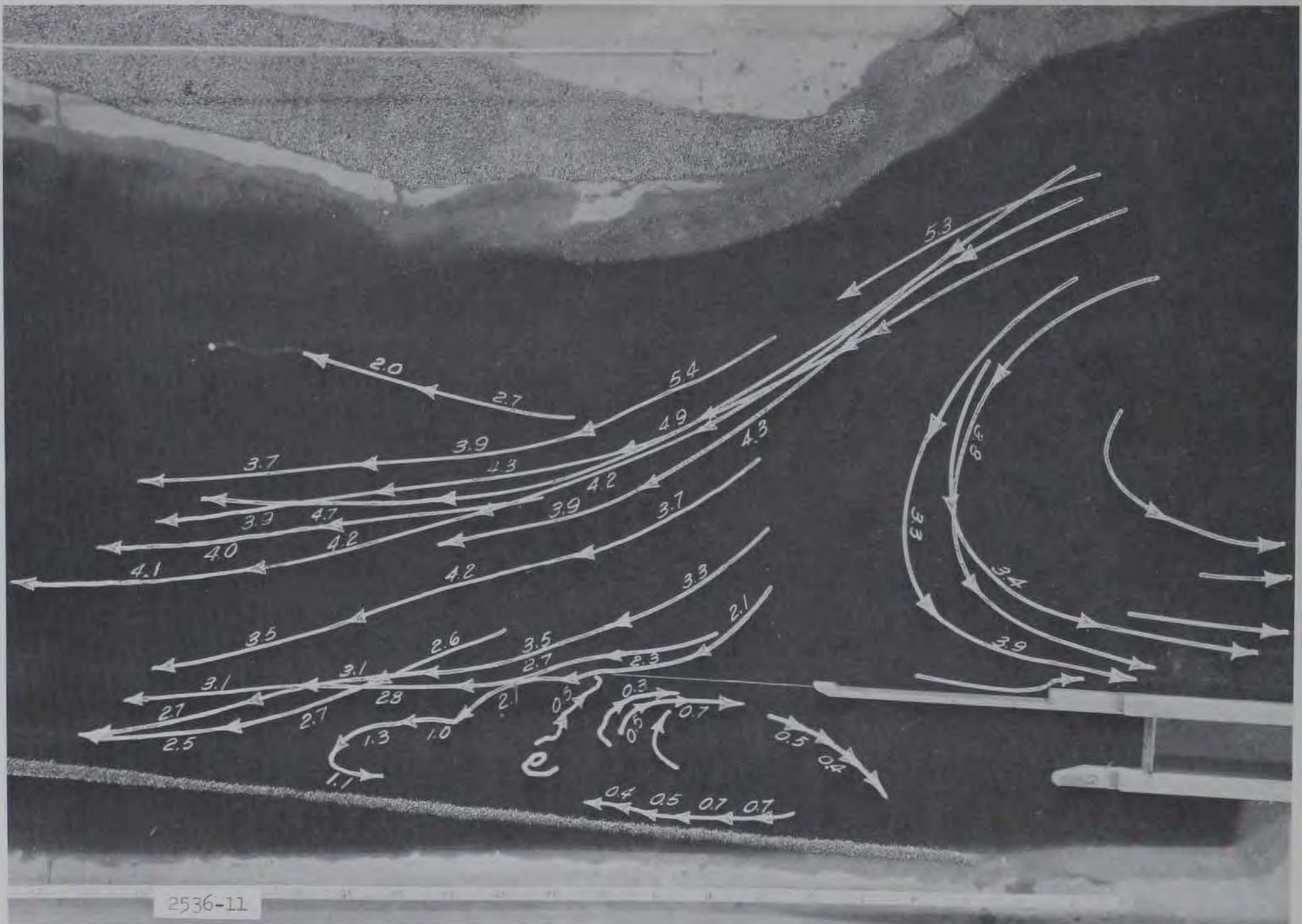

Photograph 3. Paths of floats (submerged 9 ft) during period 44-55 min after start of powerhouse release. Powerhouse discharge increased from 0 to 50,000 cfs in 6 sec (prototype). Numbers indicate average velocity in feet per second during 11-min period

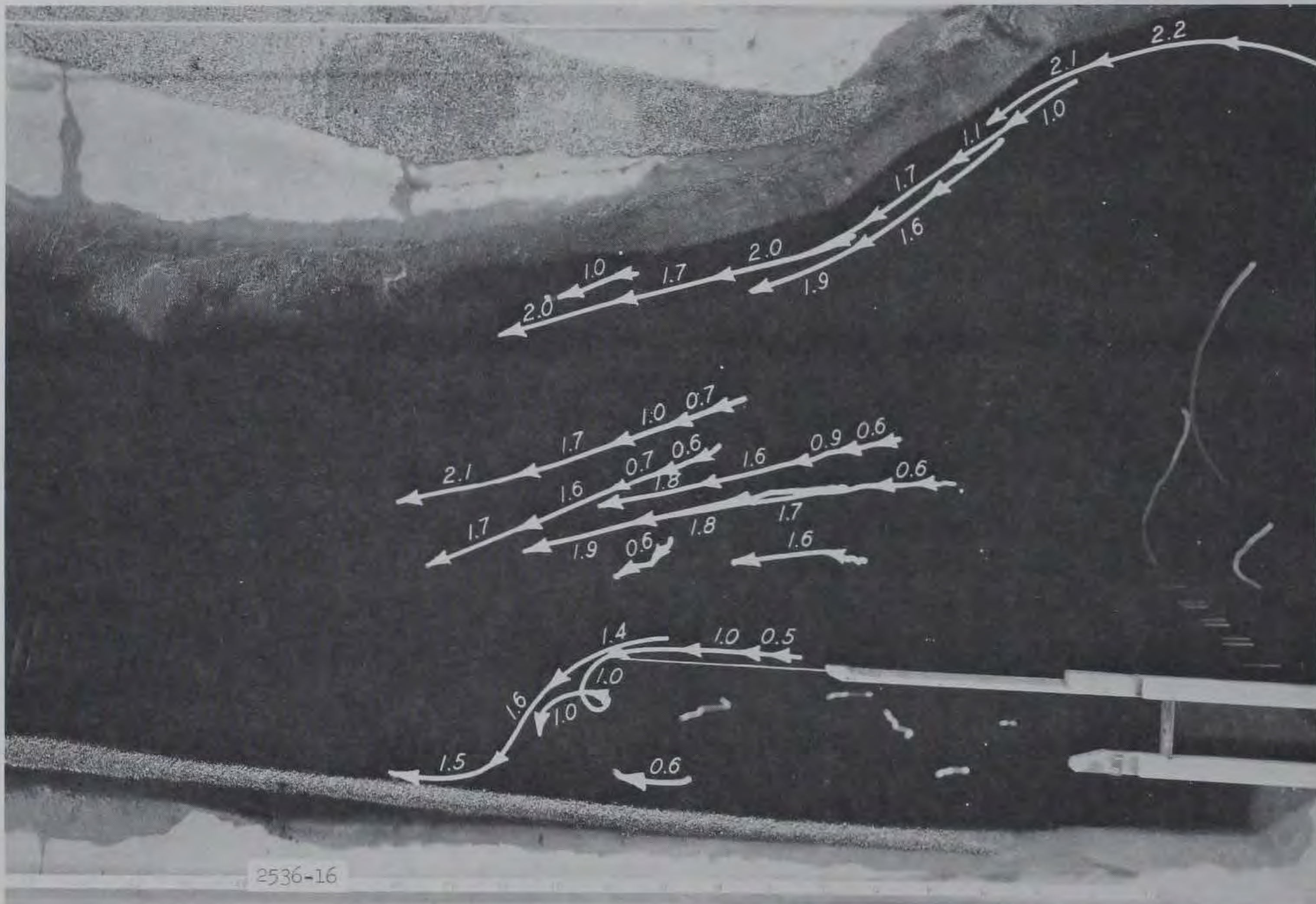

Photograph 4. Paths of floats (submerged 9 ft) during the period 0-11 min after start of powerhouse release. Powerhouse discharge increased from 0 to 50,000 cfs in 25 min (prototype). Numbers indicate average velocity in feet per second during 11-min period

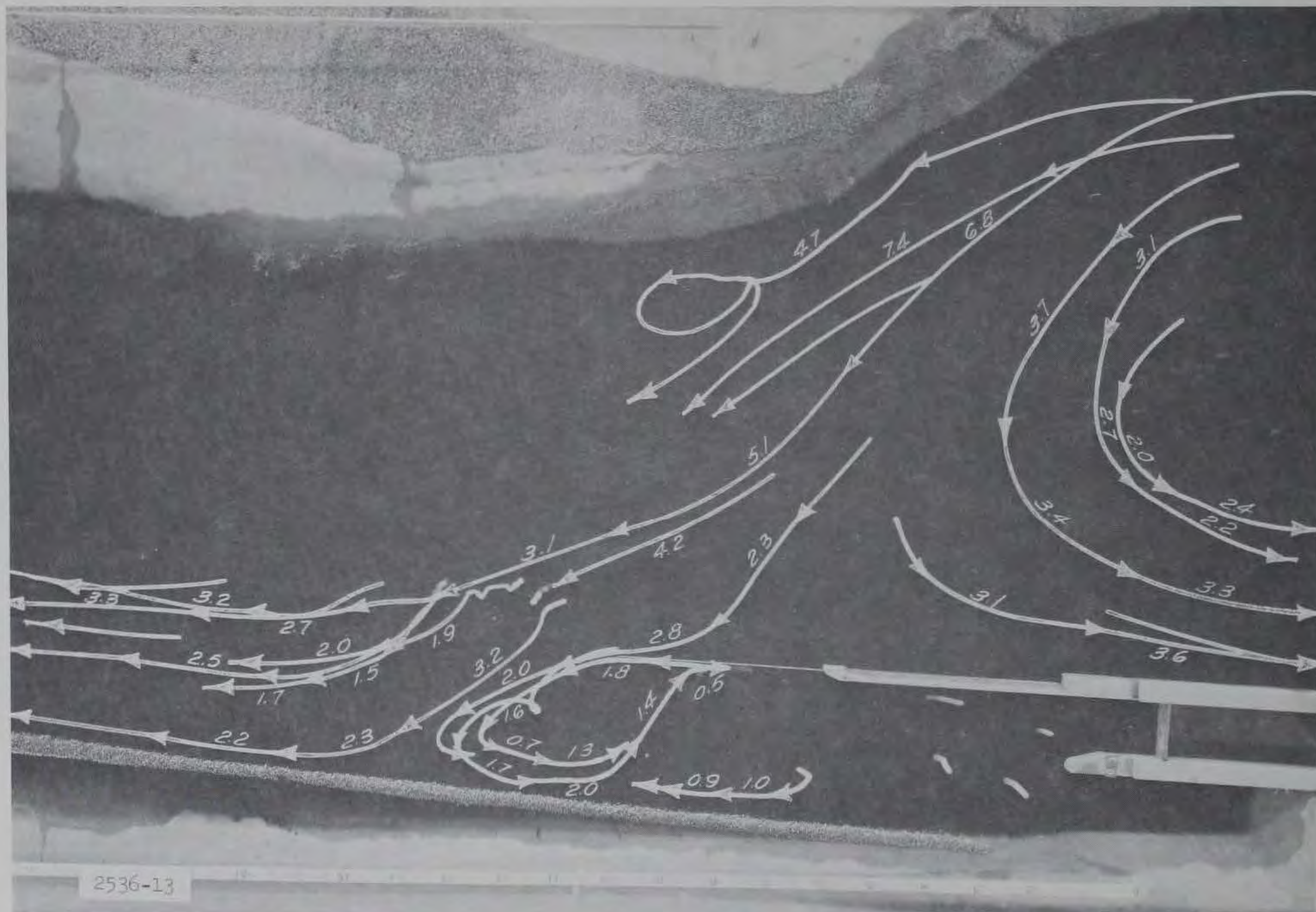

Photograph 5. Paths of floats (submerged 9 ft) during the period 22-33 min after start of powerhouse release. Powerhouse discharge increased from 0 to 50,000 cfs in 25 min (prototype). Numbers indicate average velocity in feet per second during 11-min period

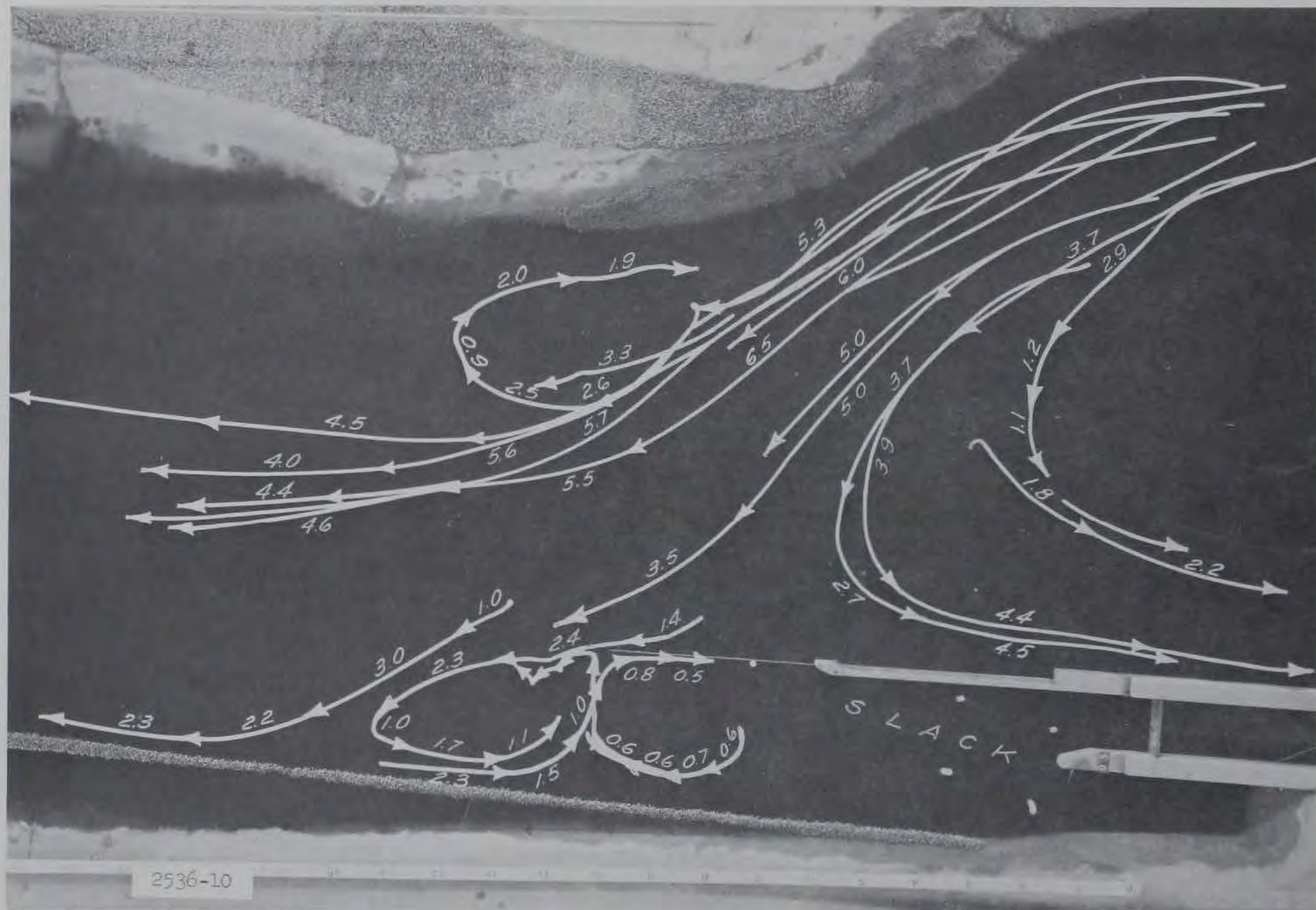

Photograph 6. Paths of floats (submerged 9 ft) during the period 44-55 min after start of powerhouse release. Powerhouse discharge increased from 0 to 50,000 cfs in 25 min (prototype). Numbers indicate average velocity in feet per second during 11-min period

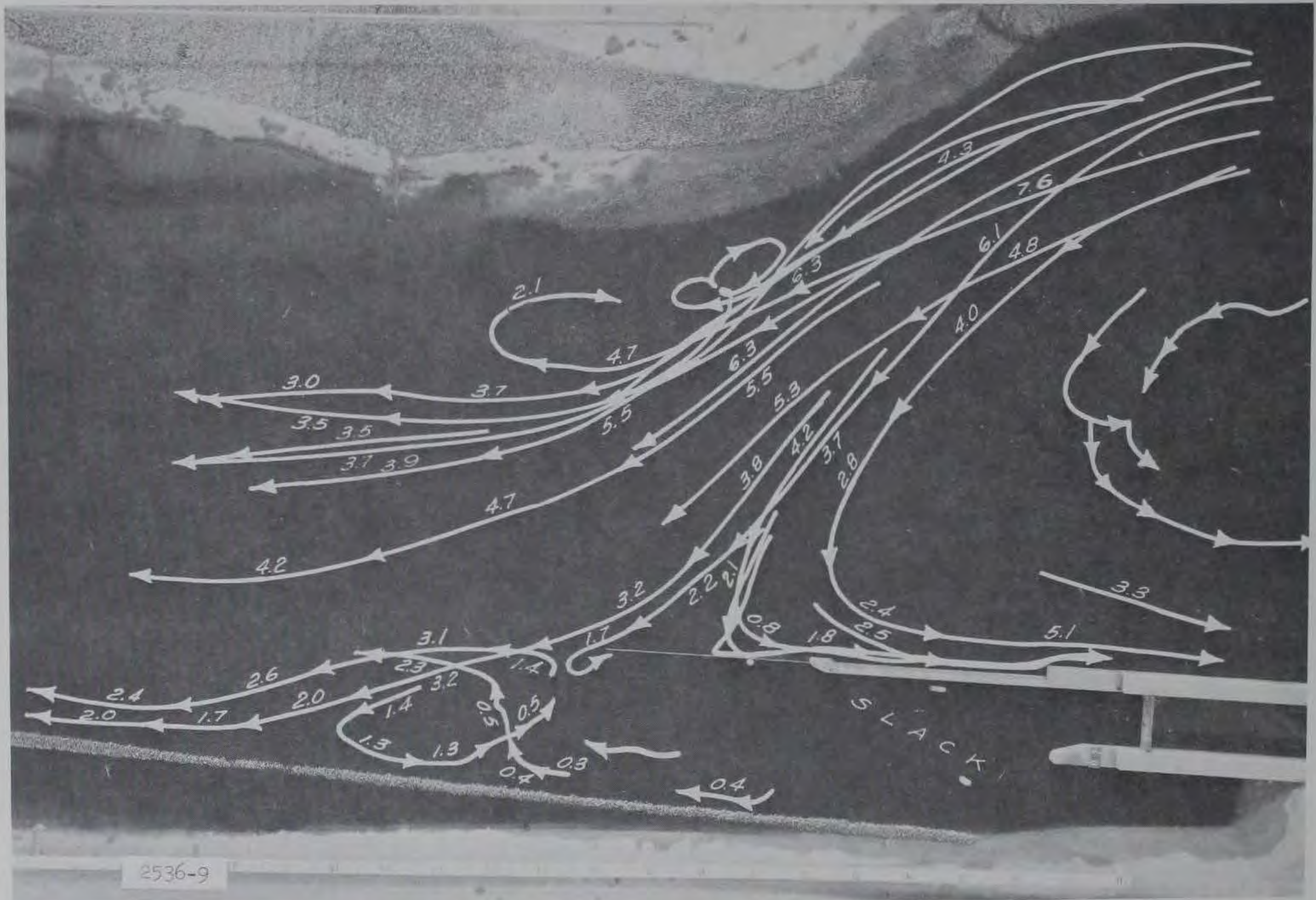

Photograph 7. Paths of floats (submerged 9 ft) during the period 66-77 min after start of powerhouse release. Powerhouse discharge increased from 0 to 50,000 cfs in 25 min (prototype). Numbers indicate average velocity in feet per second during 11-min period

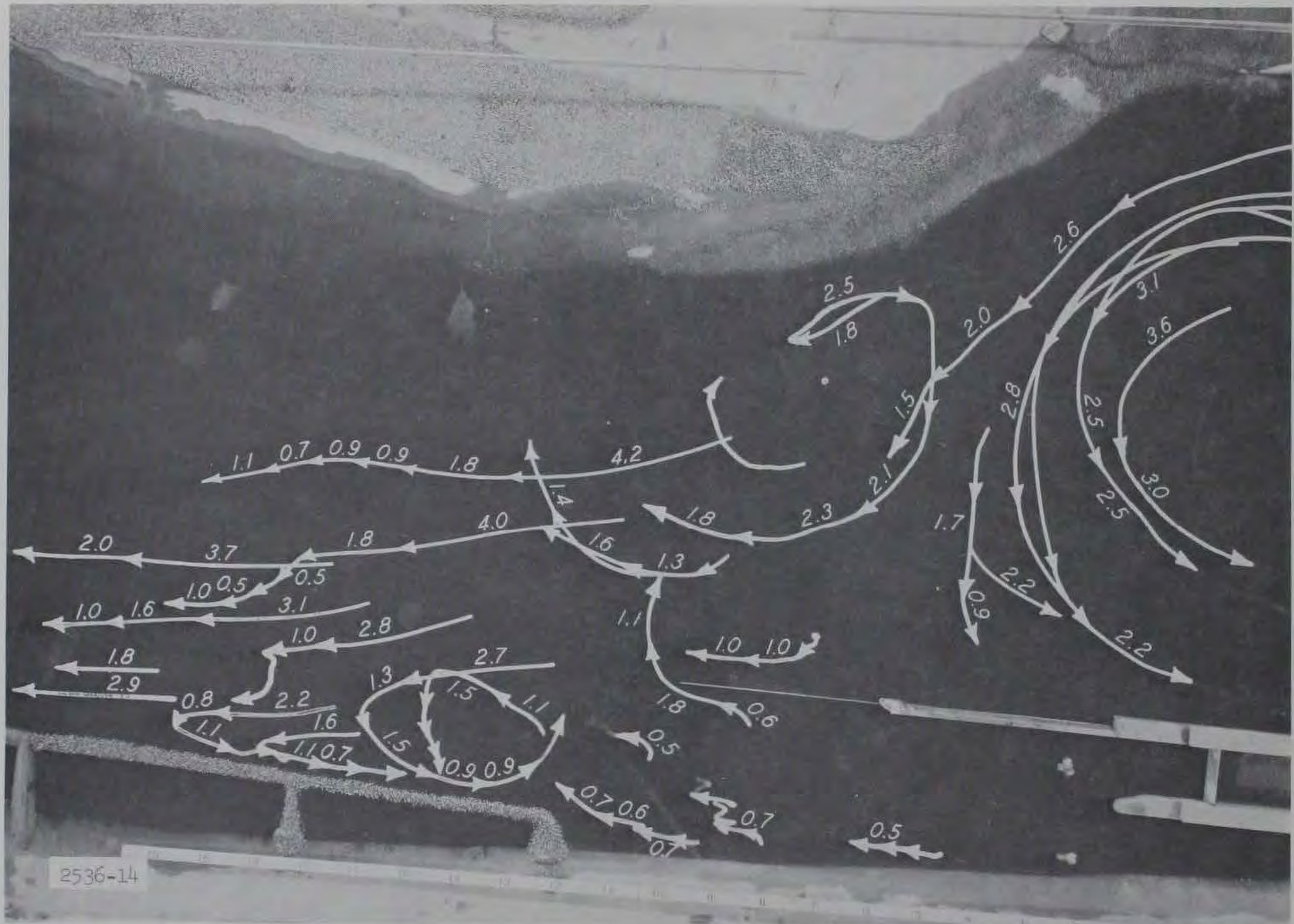

Photograph 8. Paths of floats (submerged 9 ft) during the period 0-11 min after start of cut-off of powerhouse release. Powerhouse discharge decreased from 50,000 to 0 cfs in 6 sec (prototype). Numbers indicate average velocity in feet per second during 11-min period

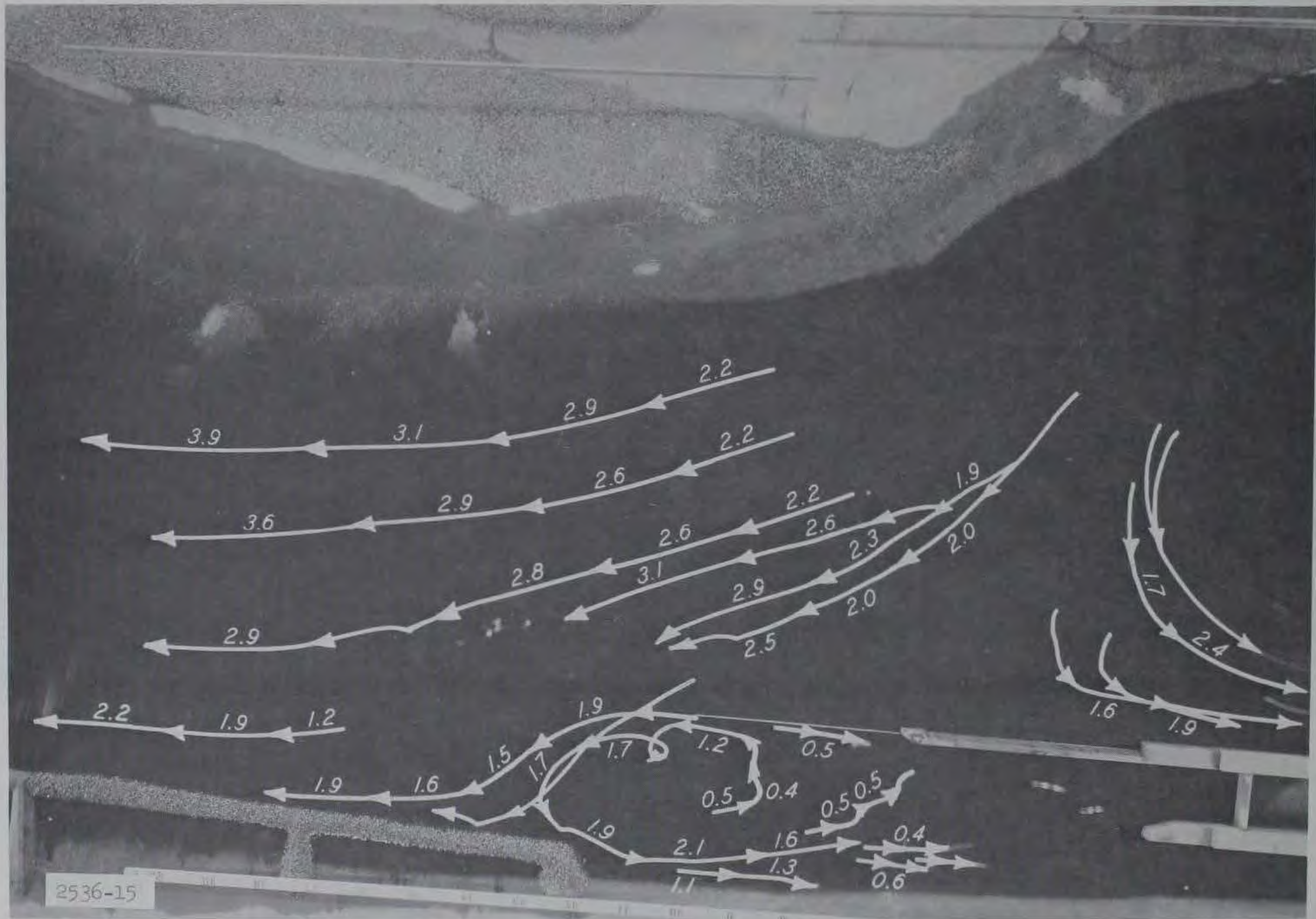

Photograph 9. Paths of floats (submerged 9 ft) during the period 11-22 min after start of powerhouse release. Powerhouse discharge increased from 0 to 50,000 cfs in 25 min (prototype). Numbers indicate average velocity in feet per second during 11-min period

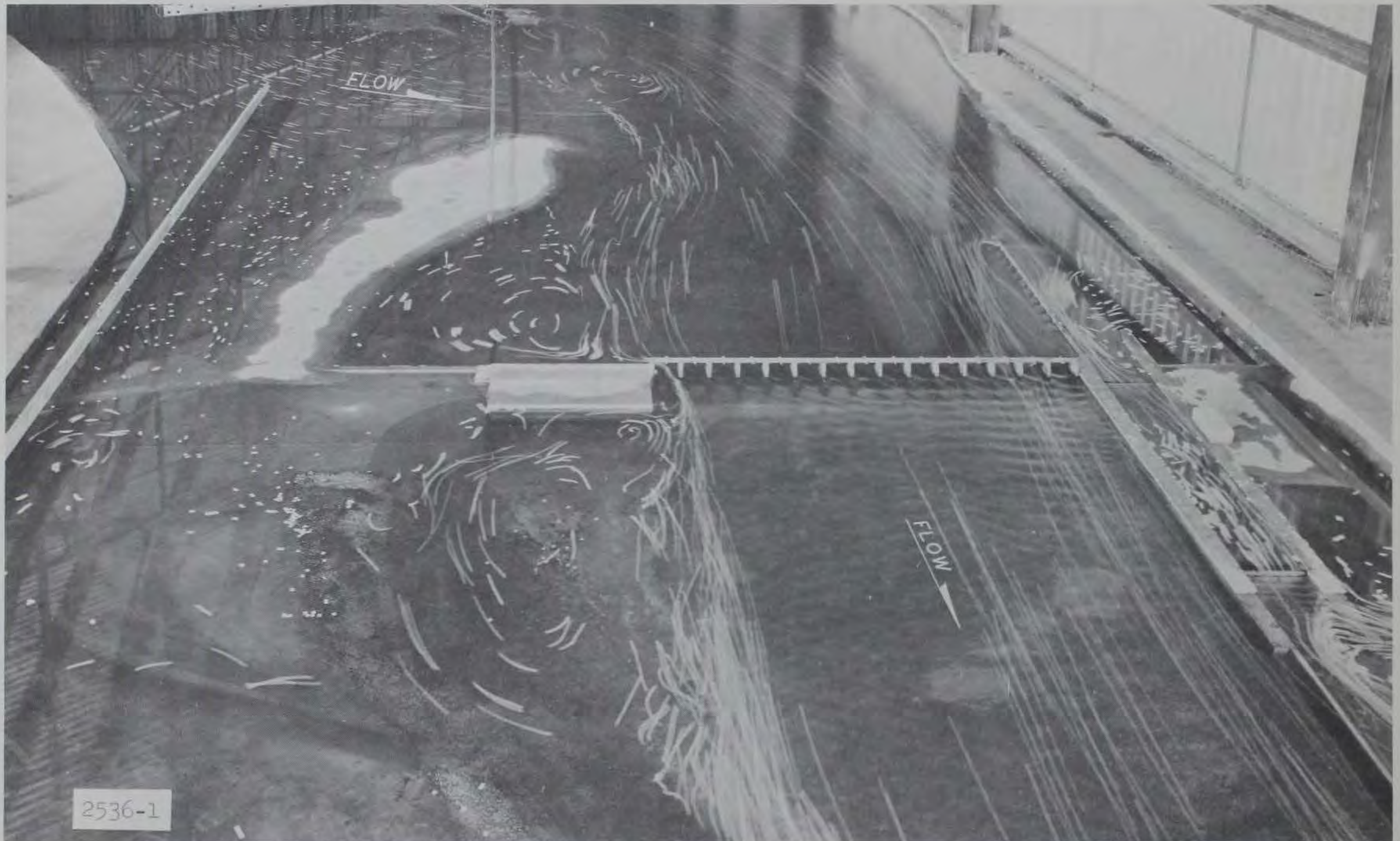

Photograph 10. Discharge 800,000 cfs; surface currents in vicinity of the structures with the right bank access road in place

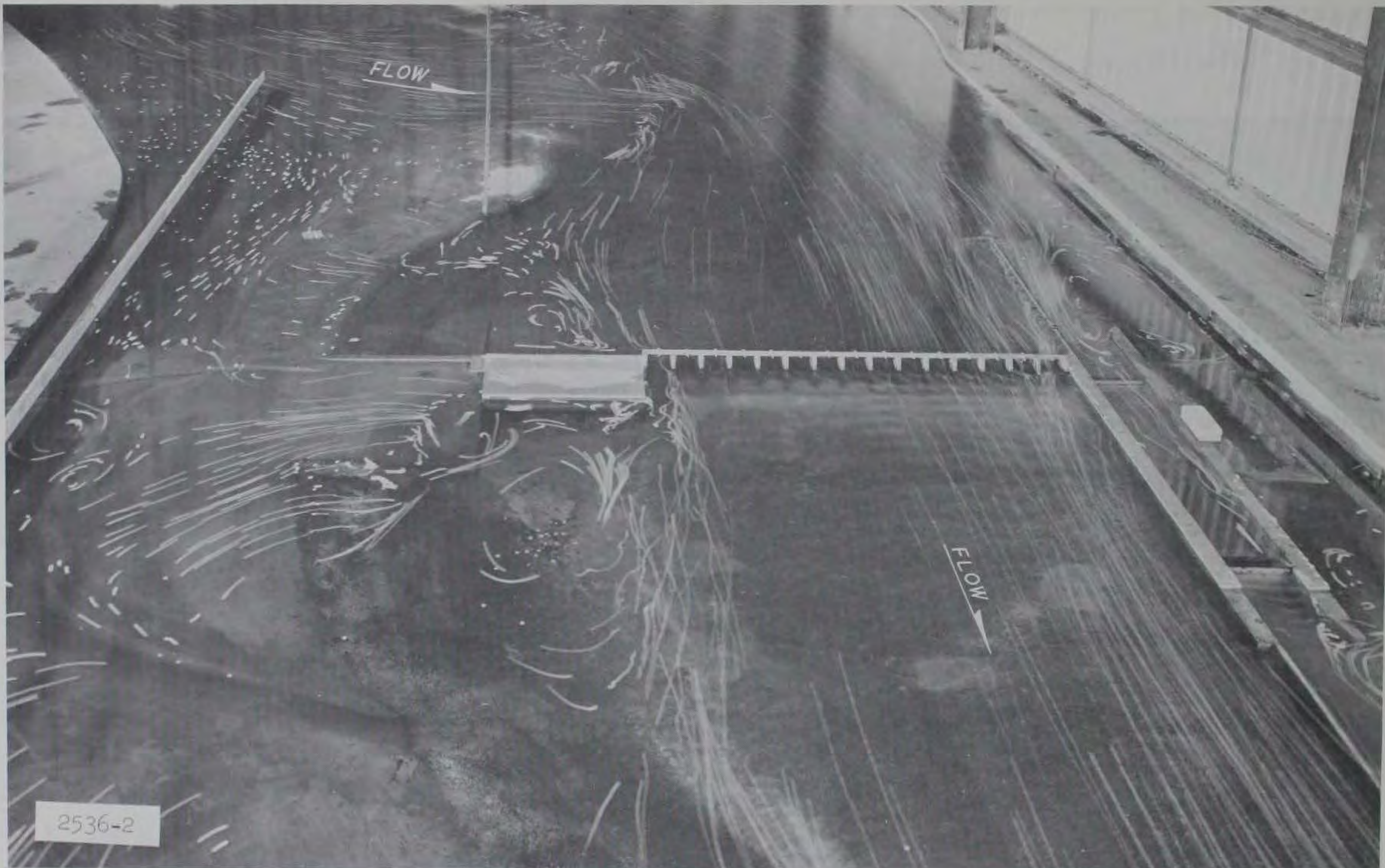

Photograph 11. Discharge 920,000 cfs; surface currents in vicinity of the structures with the right bank access road in place

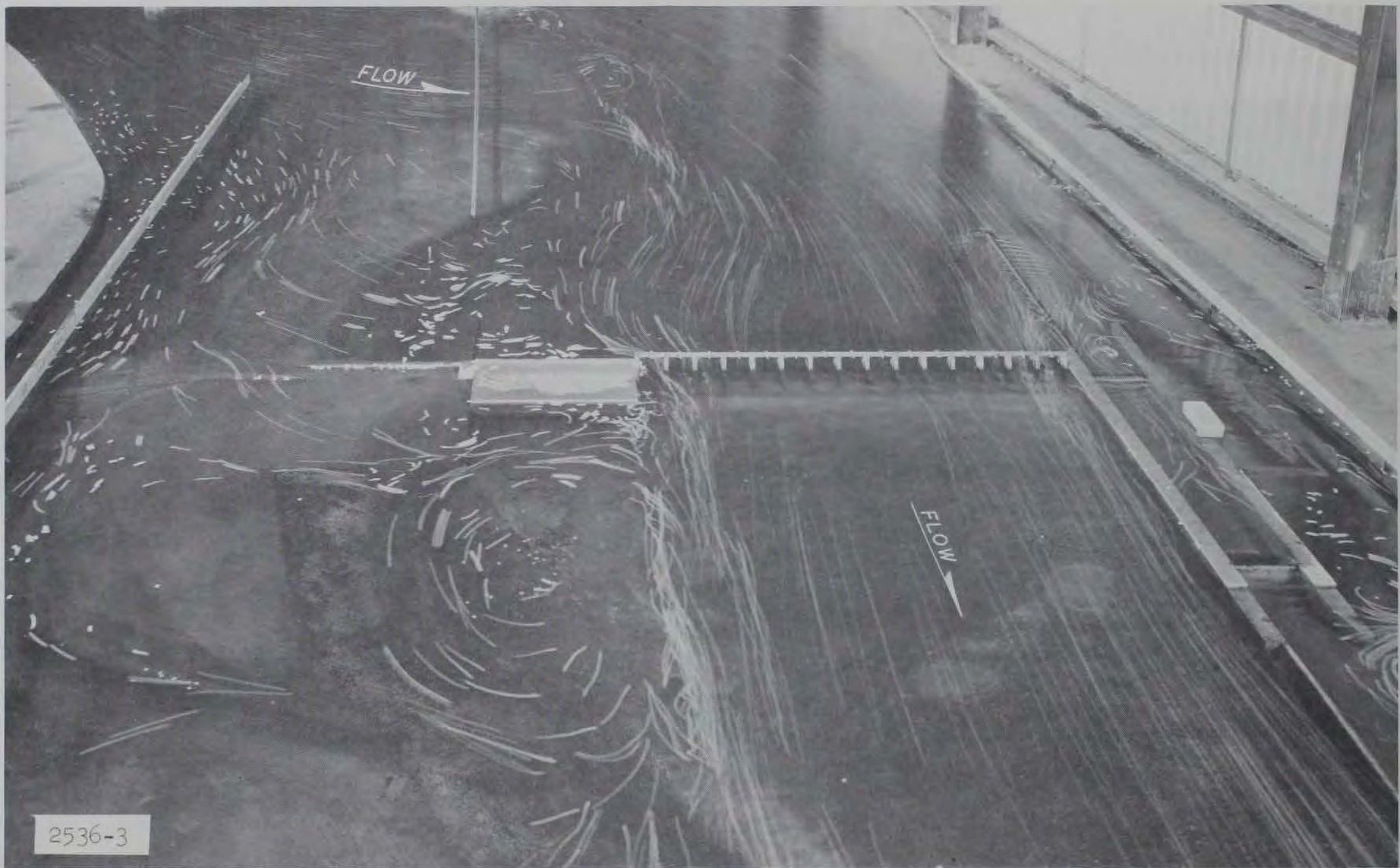

Photograph 12. Discharge 1,000,000 cfs; surface currents in vicinity of the structures with the right bank access road in place

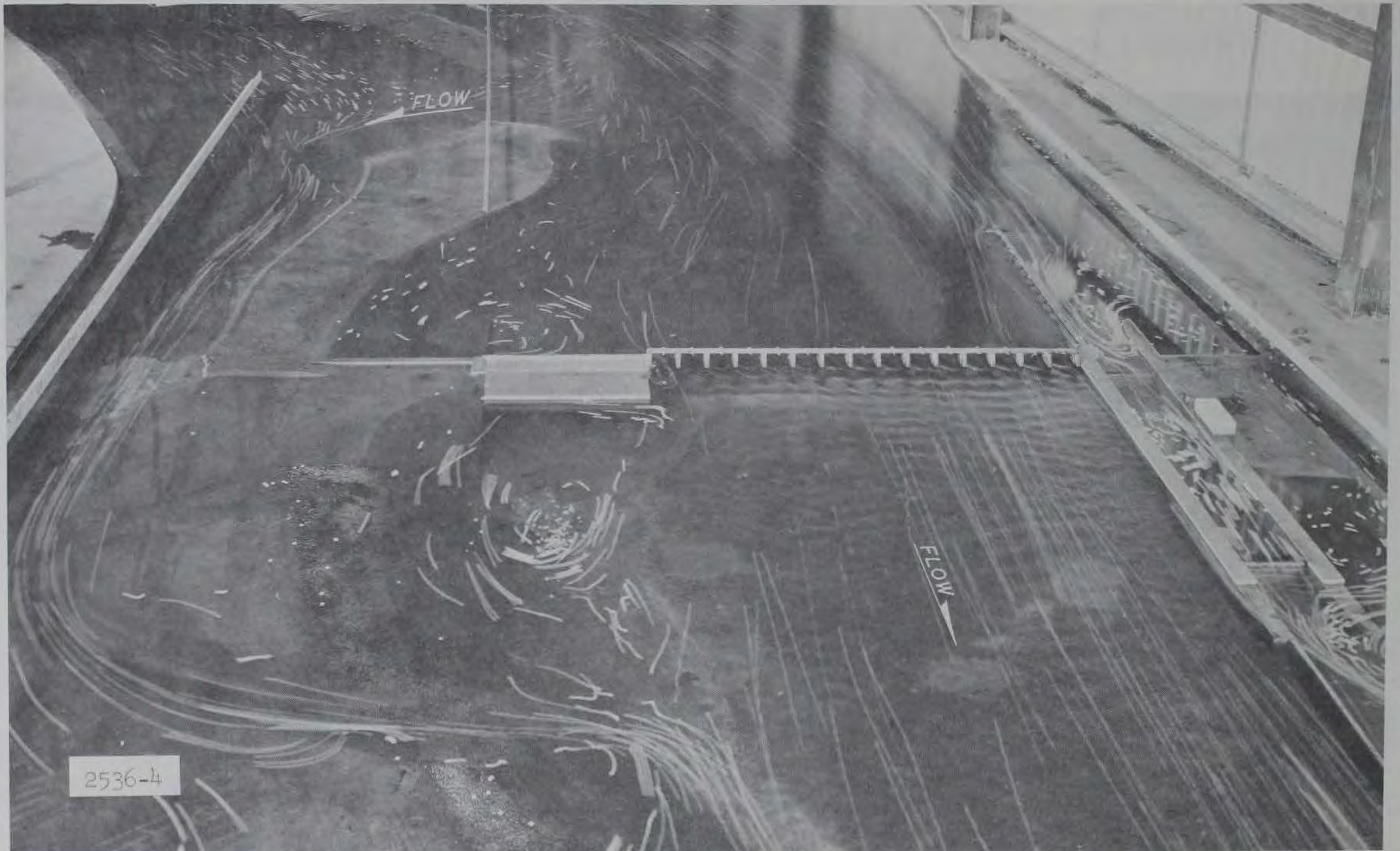

Photograph 13. Discharge 800,000 cfs; surface currents in vicinity of the structures with the right bank access road removed

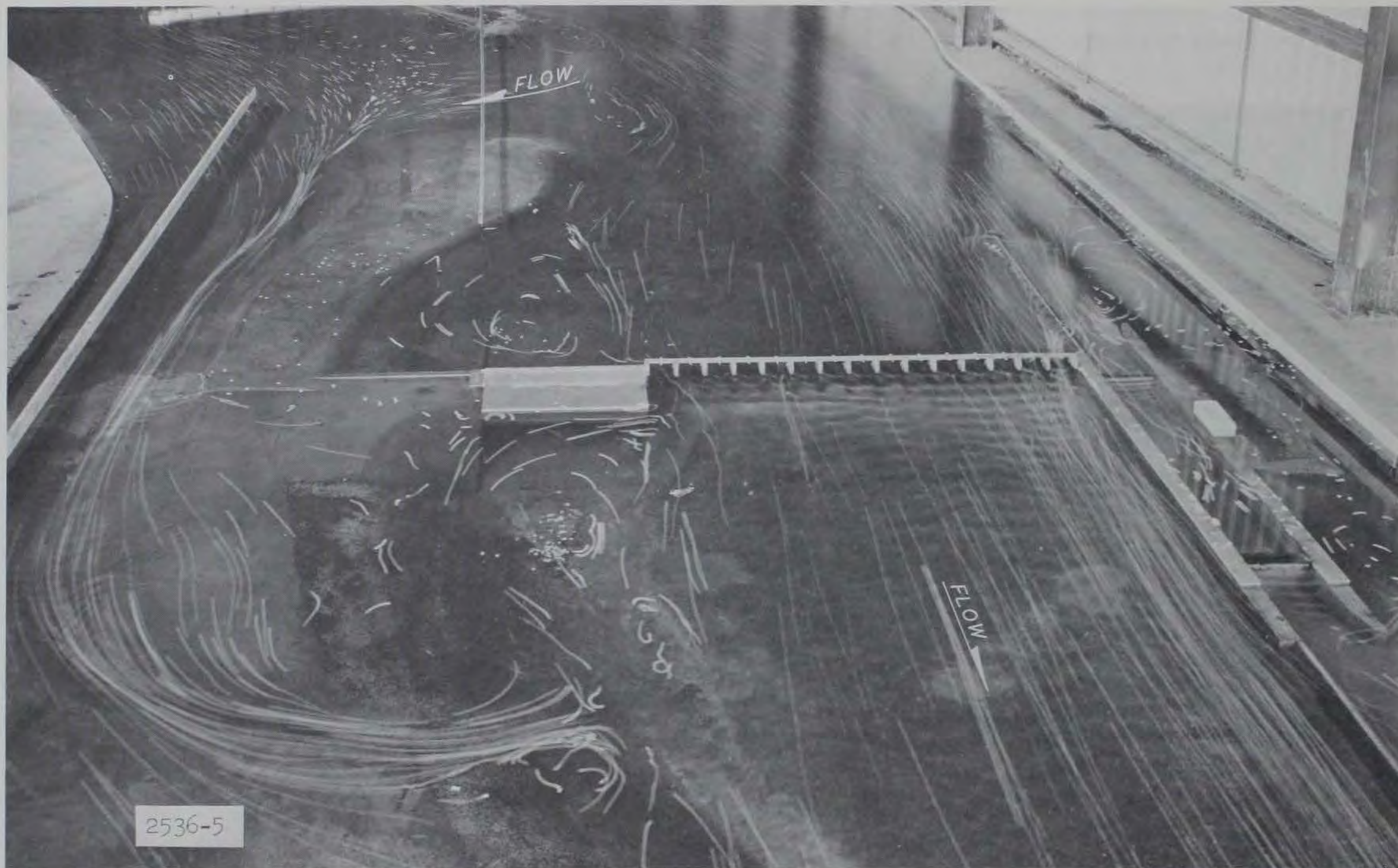

Photograph 14. Discharge 920,000 cfs; surface currents in vicinity of the structures with the right bank access road removed

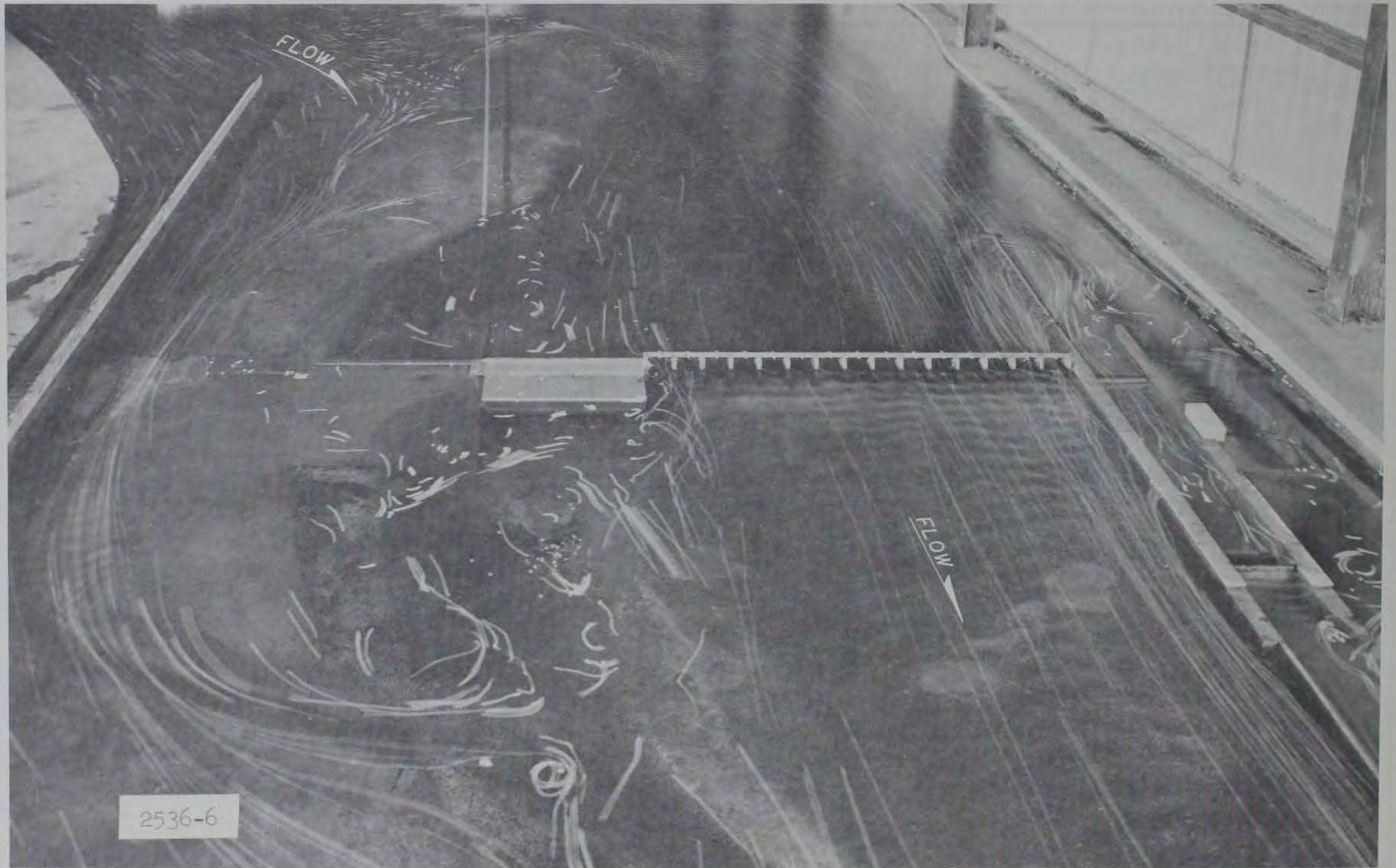

Photograph 15. Discharge 1,000,000 cfs; surface currents in vicinity of the structures with the right bank access road removed

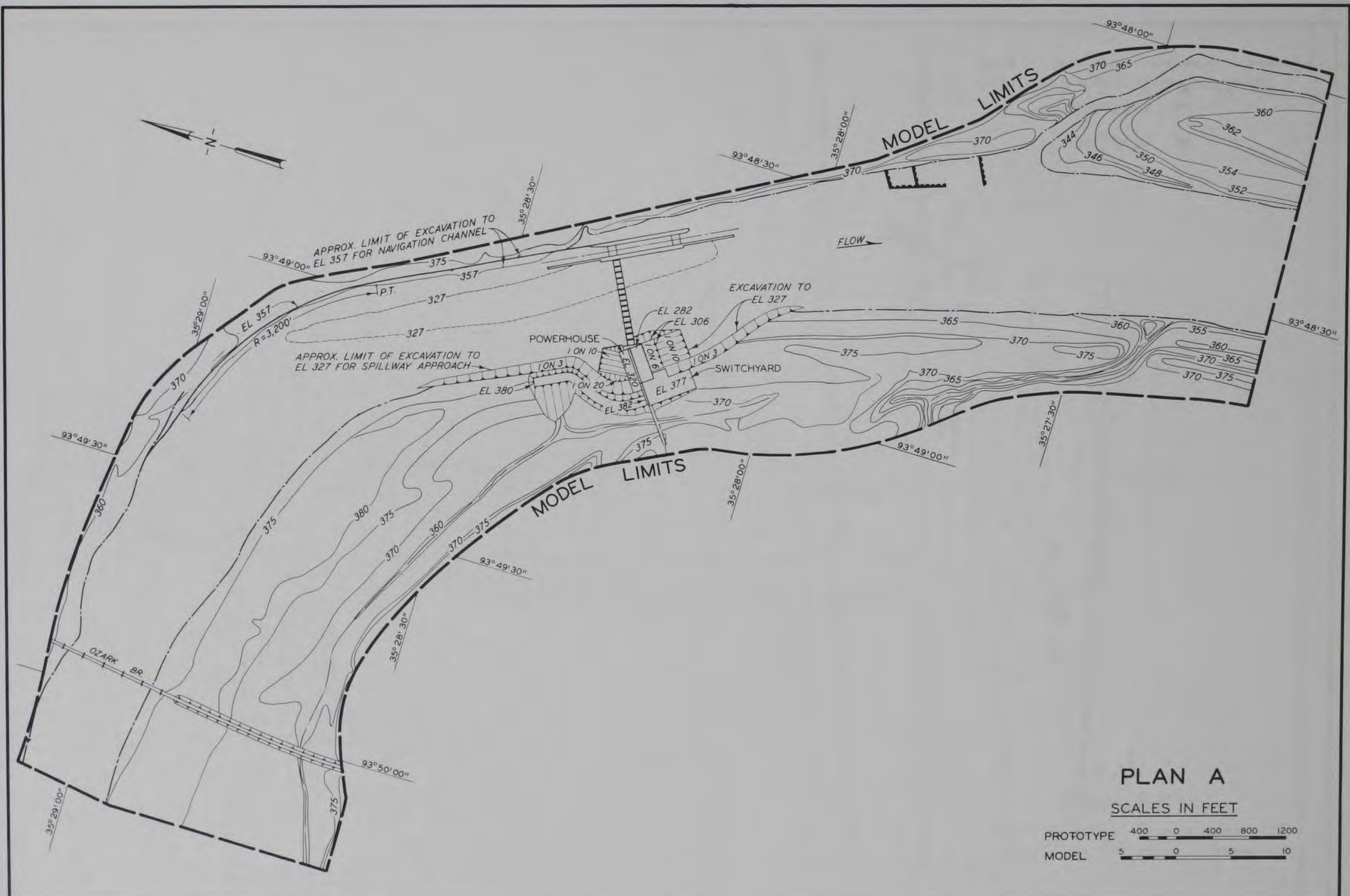

PLAN A

SCALES IN FEET



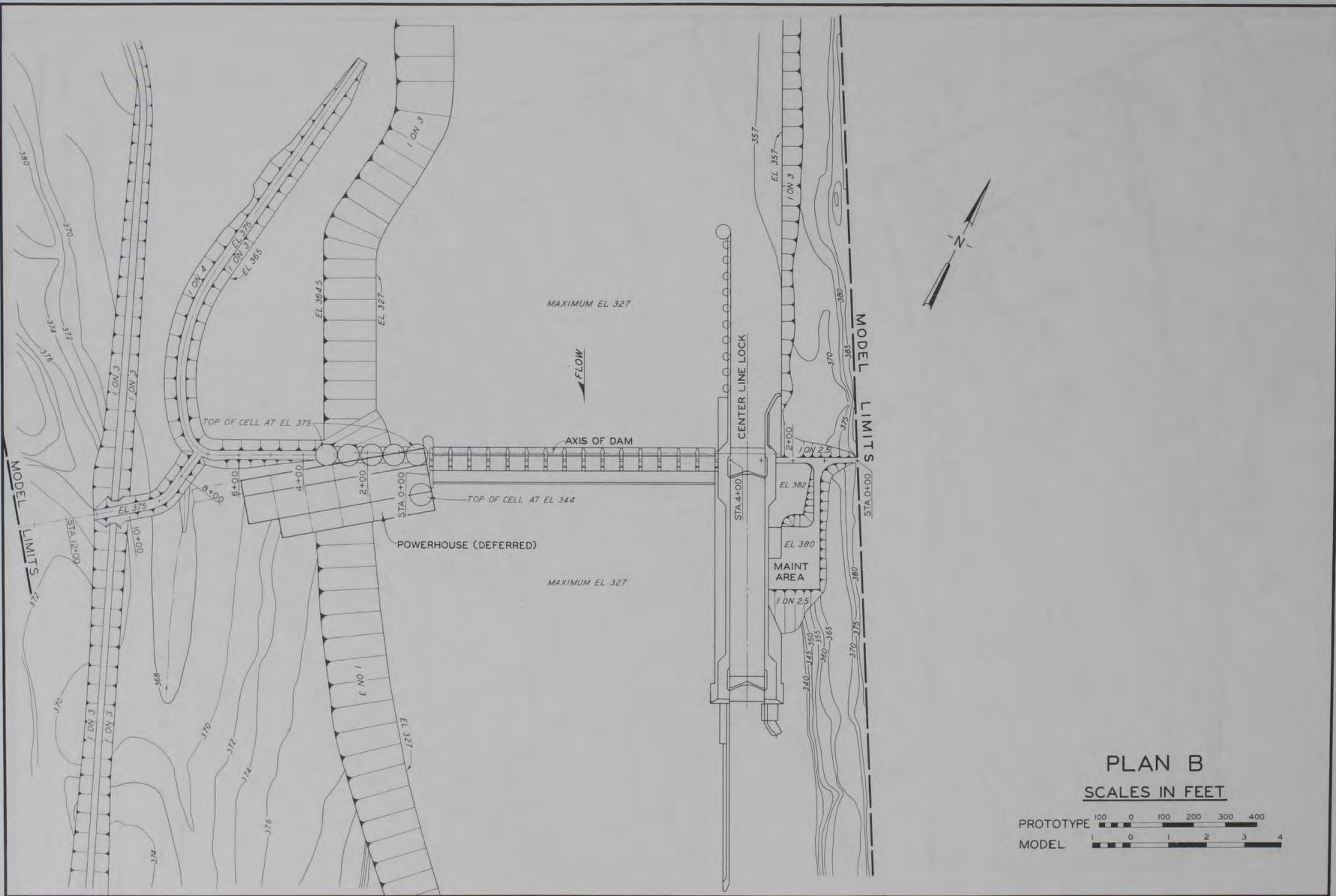

PLAN B
 SCALES IN FEET

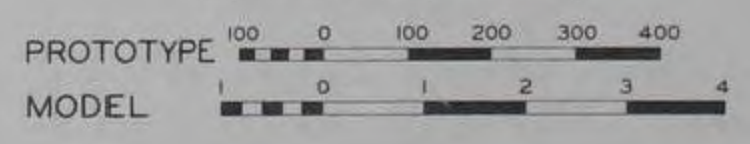

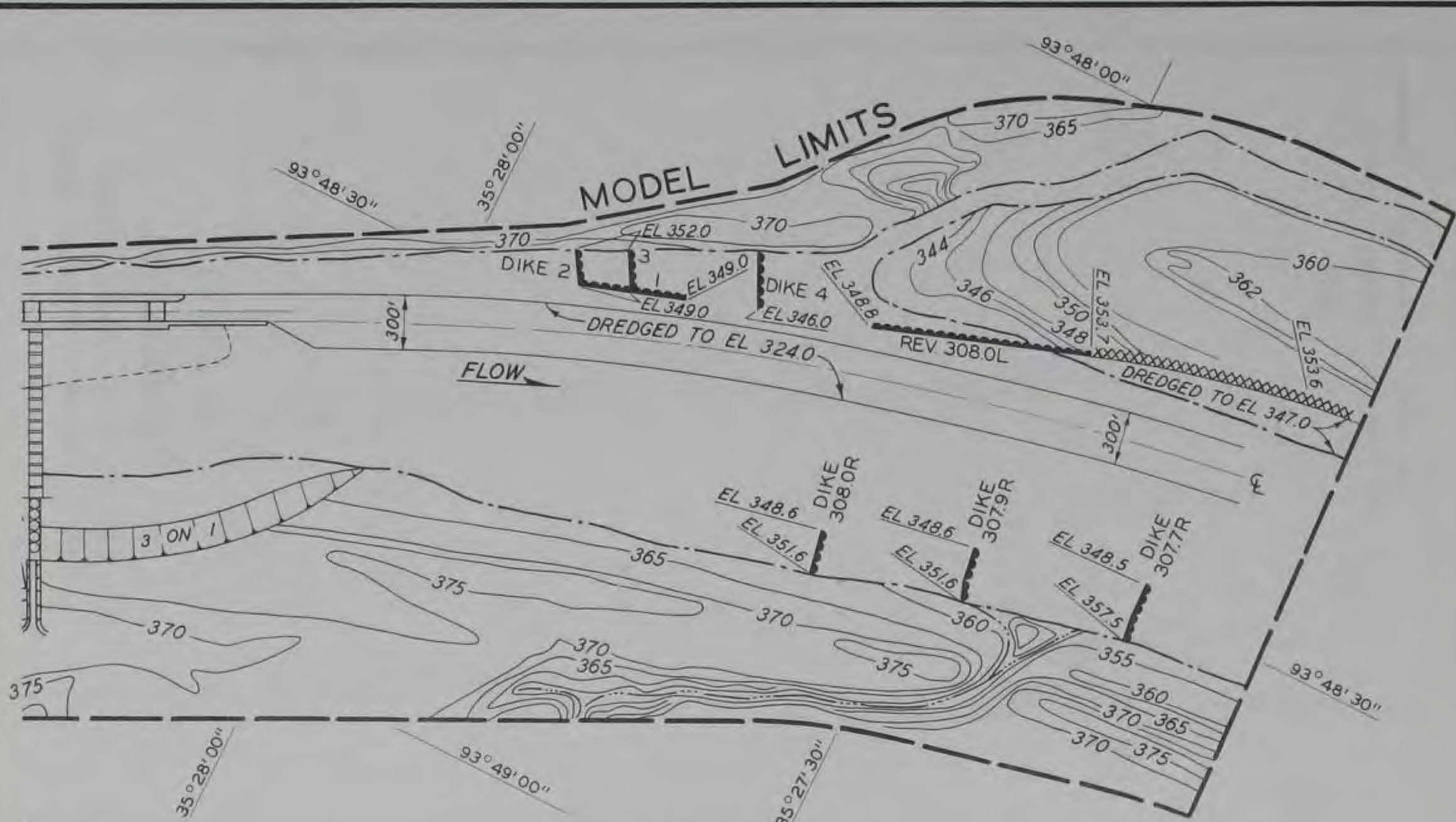

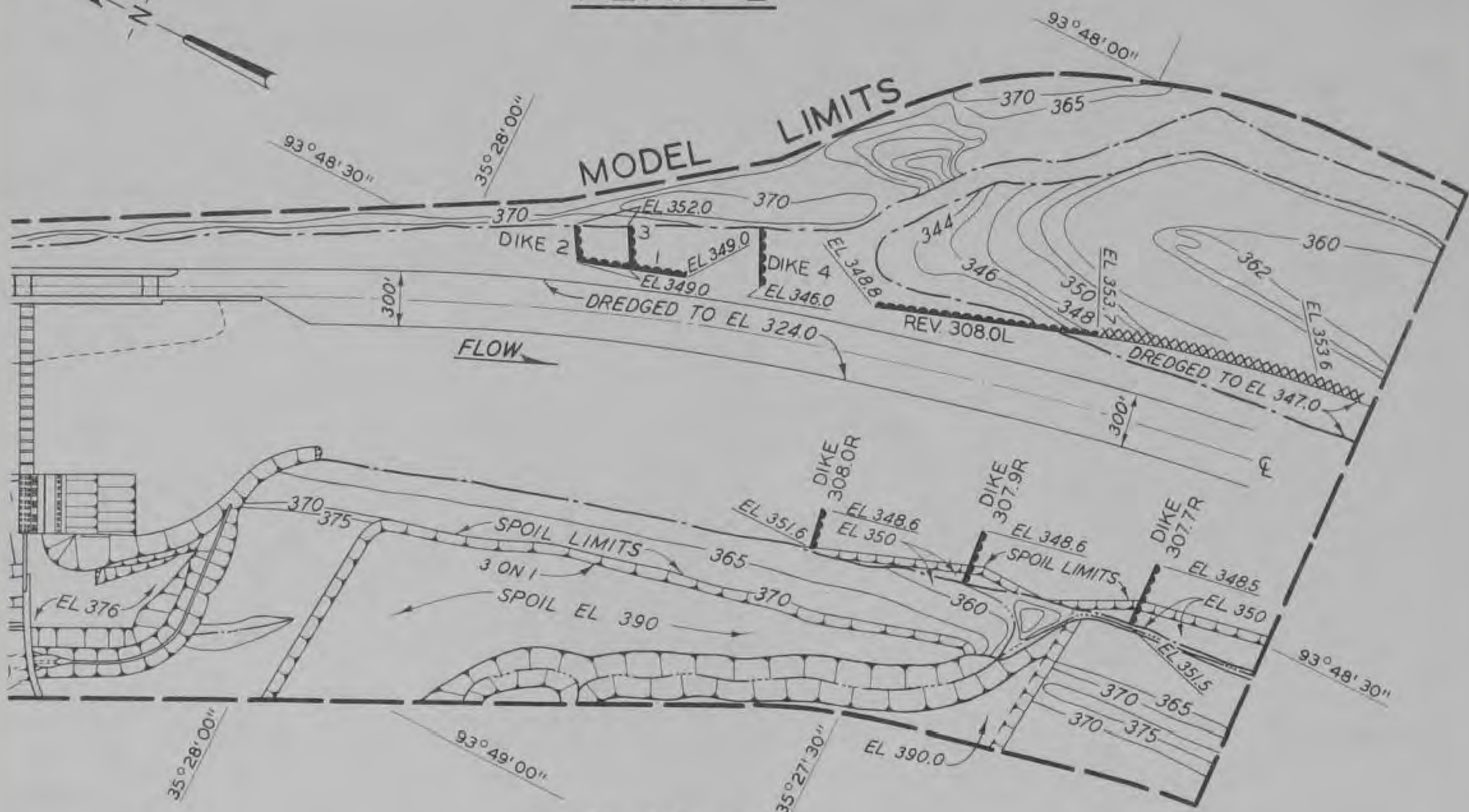

PLAN B



PLAN D

LEGEND

-  STONE FILL REVETMENT OR DIKE
-  PROPOSED TRENCH FILL REVETMENT

NOTE: ELEVATIONS AND CONTOURS REFERRED TO MEAN SEA LEVEL.

PLANS B AND D

SCALES IN FEET





PLAN C
SCALES IN FEET

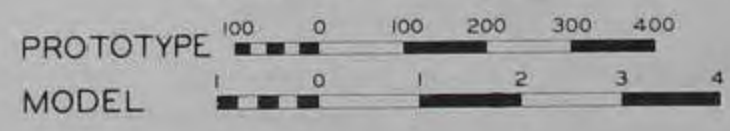

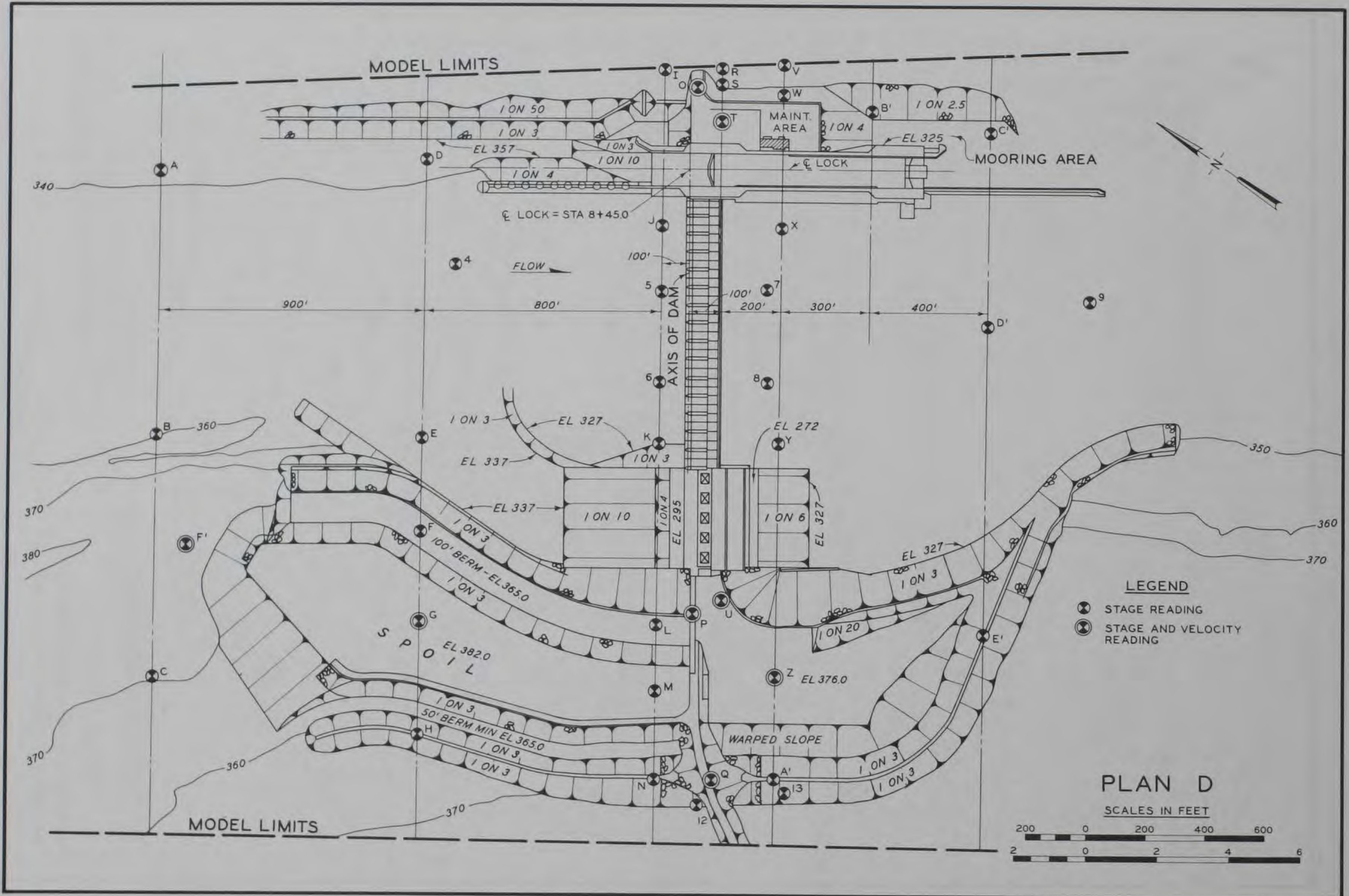

LEGEND

- ⊙ STAGE READING
- ⊙⊕ STAGE AND VELOCITY READING

PLAN D

SCALES IN FEET

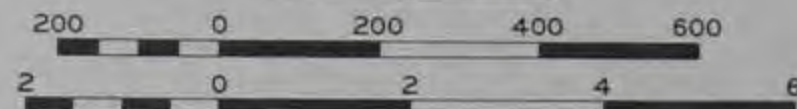

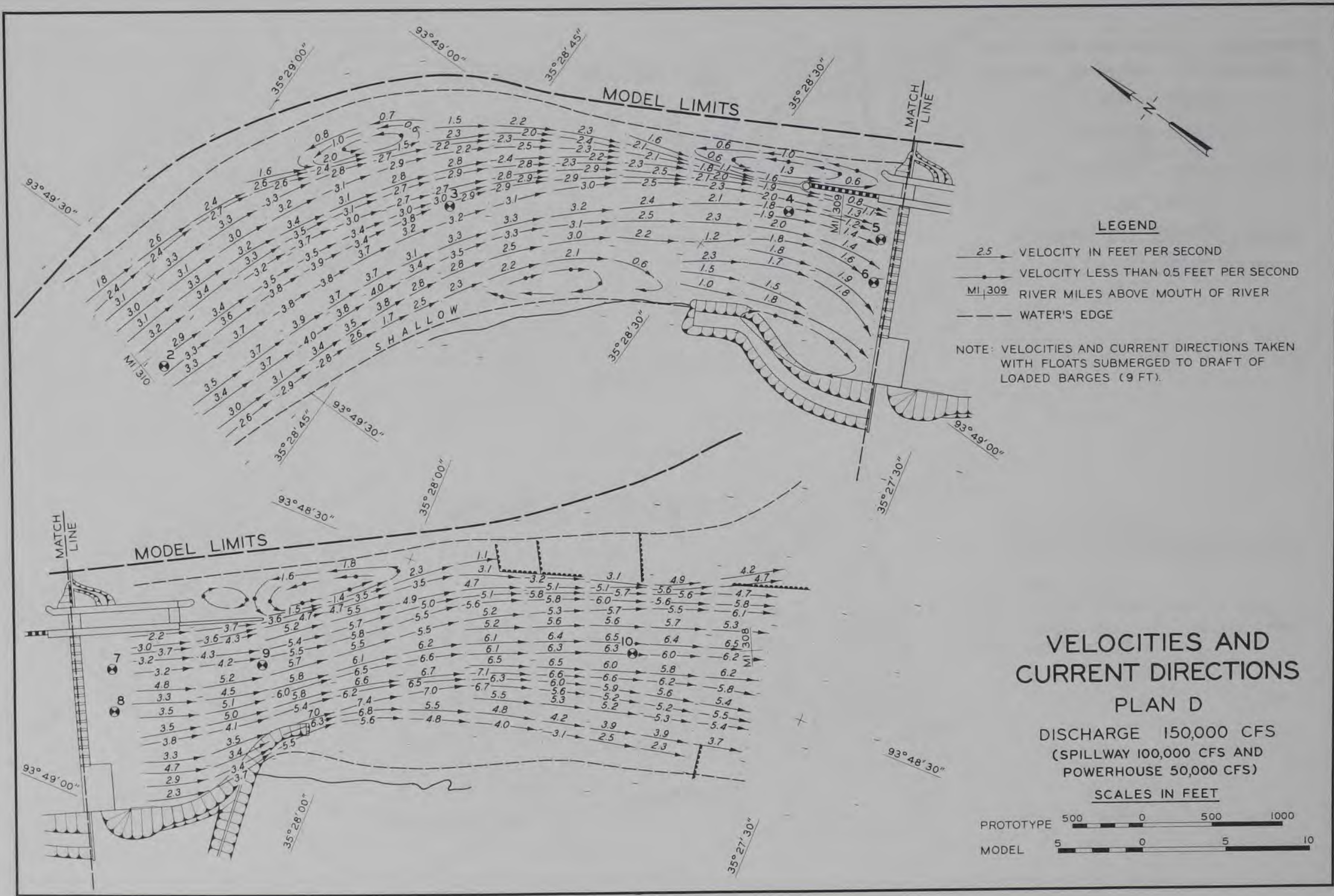

LEGEND

- 2.5 VELOCITY IN FEET PER SECOND
- VELOCITY LESS THAN 0.5 FEET PER SECOND
- MI 309 RIVER MILES ABOVE MOUTH OF RIVER
- - - WATER'S EDGE

NOTE: VELOCITIES AND CURRENT DIRECTIONS TAKEN WITH FLOATS SUBMERGED TO DRAFT OF LOADED BARGES (9 FT).

VELOCITIES AND CURRENT DIRECTIONS

PLAN D

DISCHARGE 150,000 CFS
(SPILLWAY 100,000 CFS AND
POWERHOUSE 50,000 CFS)

SCALES IN FEET

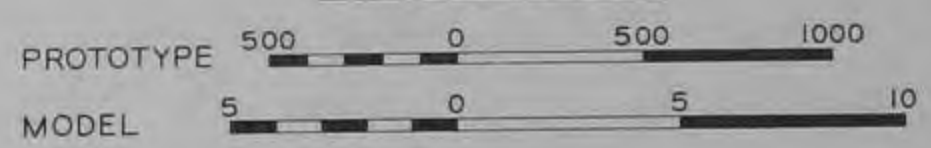

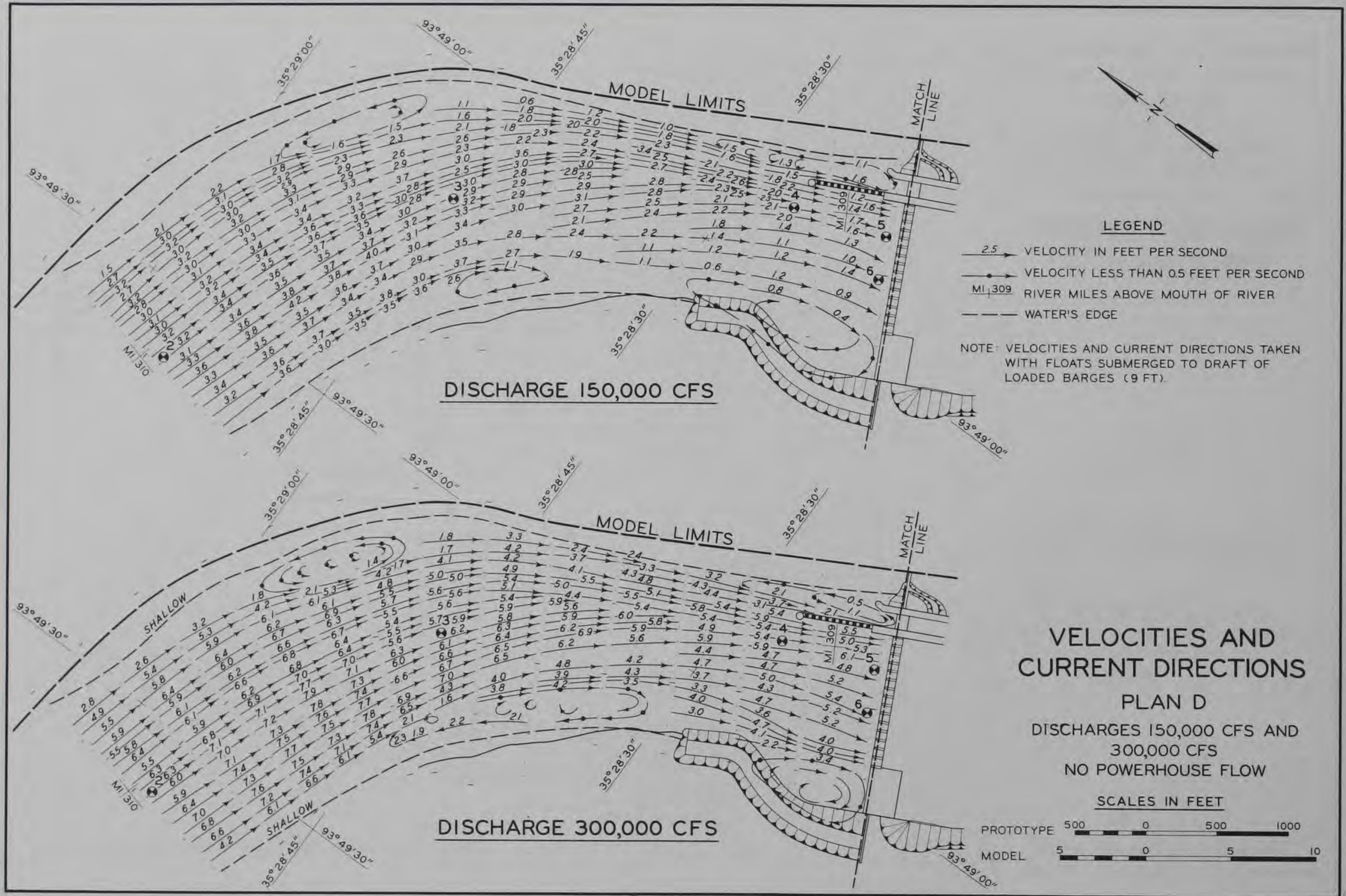

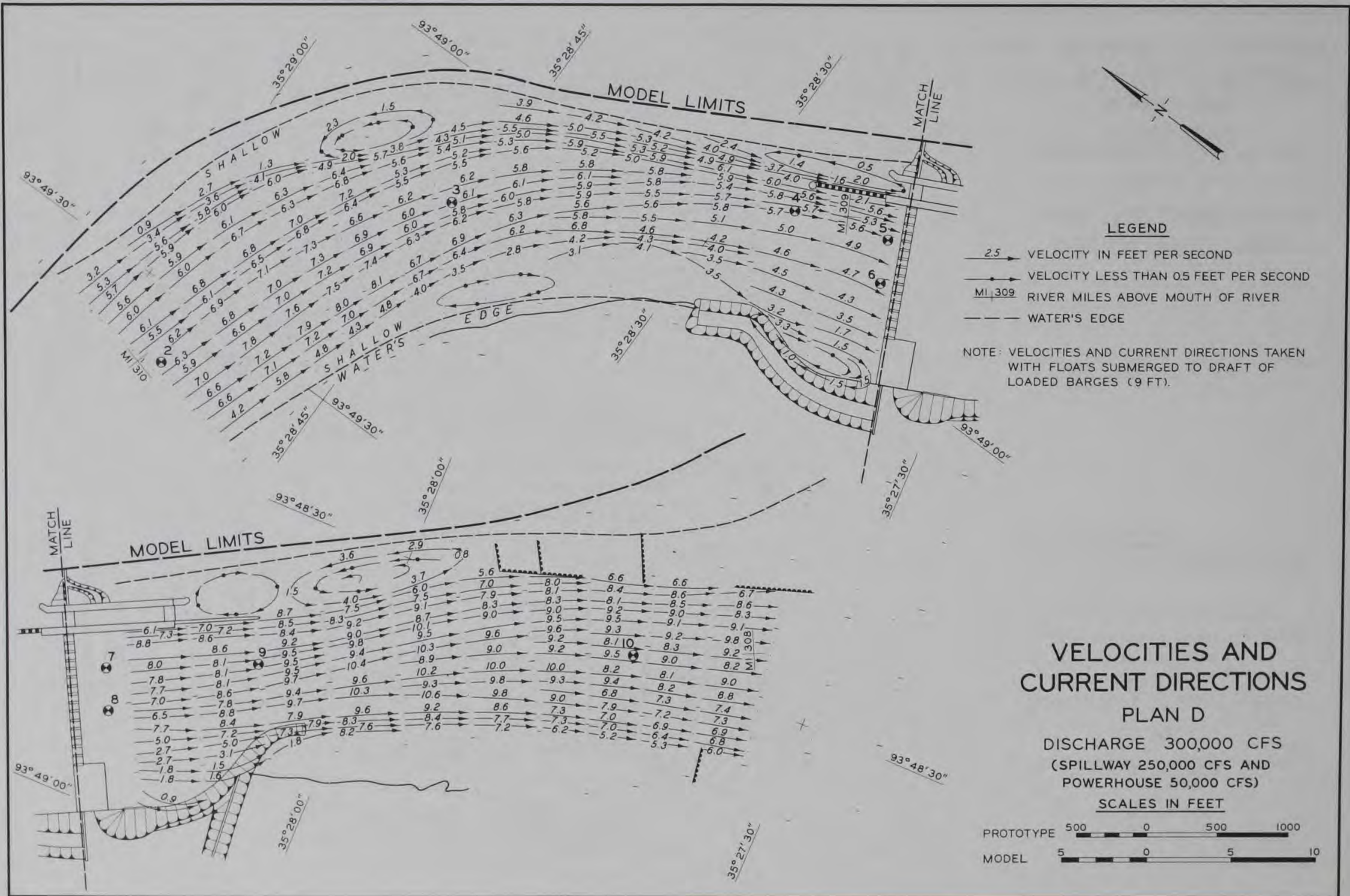

LEGEND

- 2.5 VELOCITY IN FEET PER SECOND
- - - - - VELOCITY LESS THAN 0.5 FEET PER SECOND
- MI 309 RIVER MILES ABOVE MOUTH OF RIVER
- - - - - WATER'S EDGE

NOTE: VELOCITIES AND CURRENT DIRECTIONS TAKEN WITH FLOATS SUBMERGED TO DRAFT OF LOADED BARGES (9 FT).

VELOCITIES AND CURRENT DIRECTIONS

PLAN D

DISCHARGE 300,000 CFS
 (SPILLWAY 250,000 CFS AND
 POWERHOUSE 50,000 CFS)

SCALES IN FEET



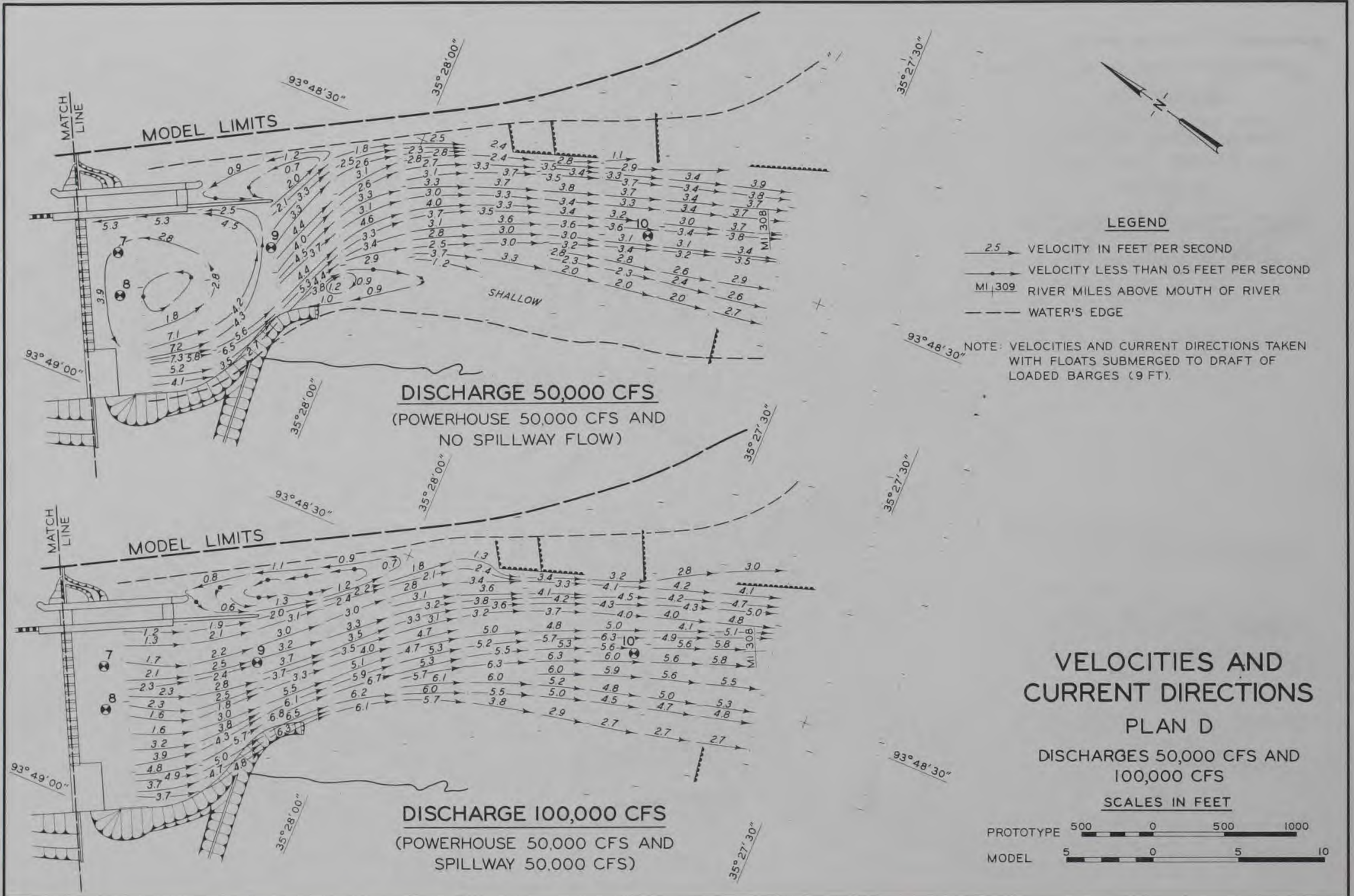

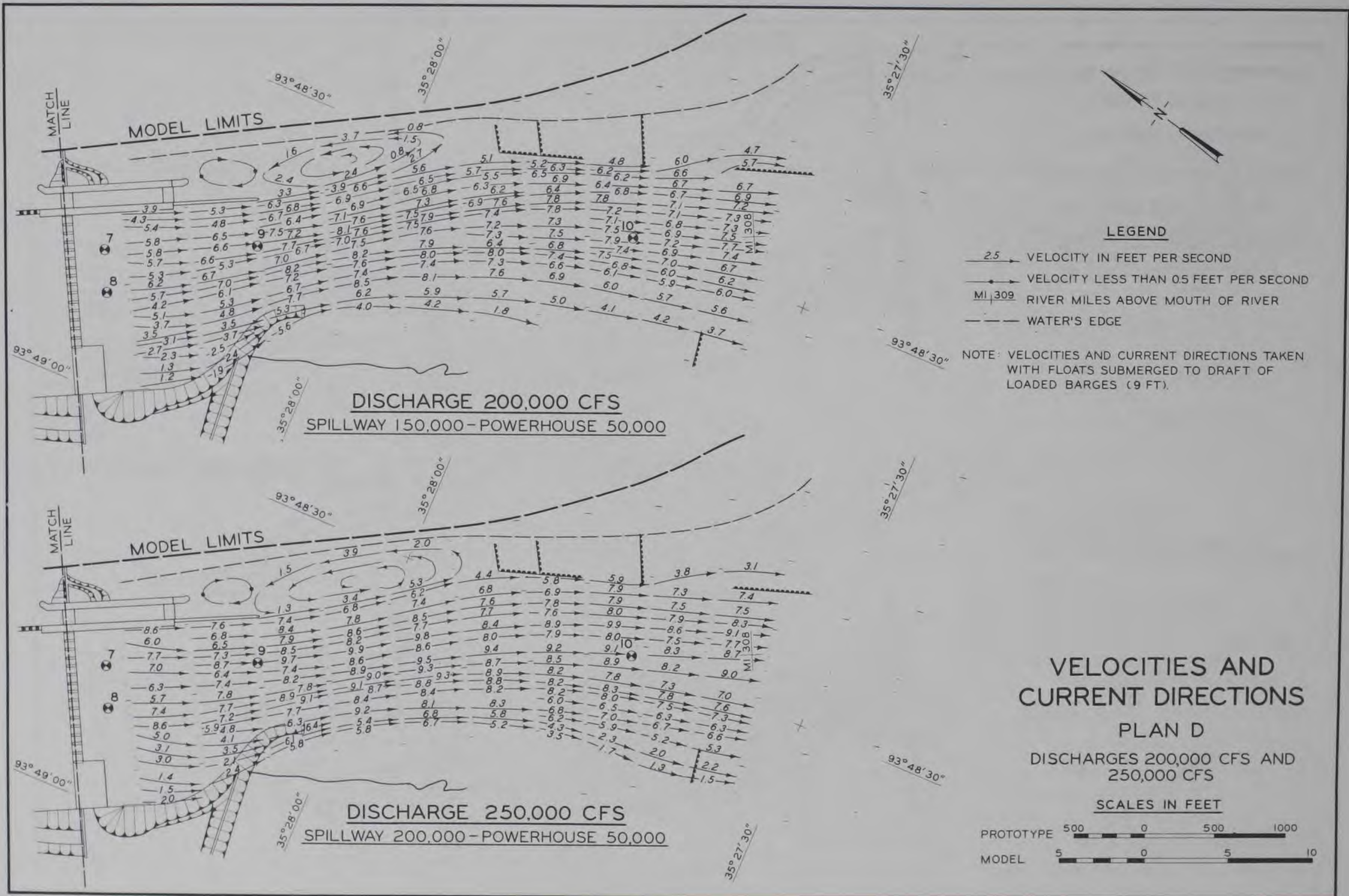

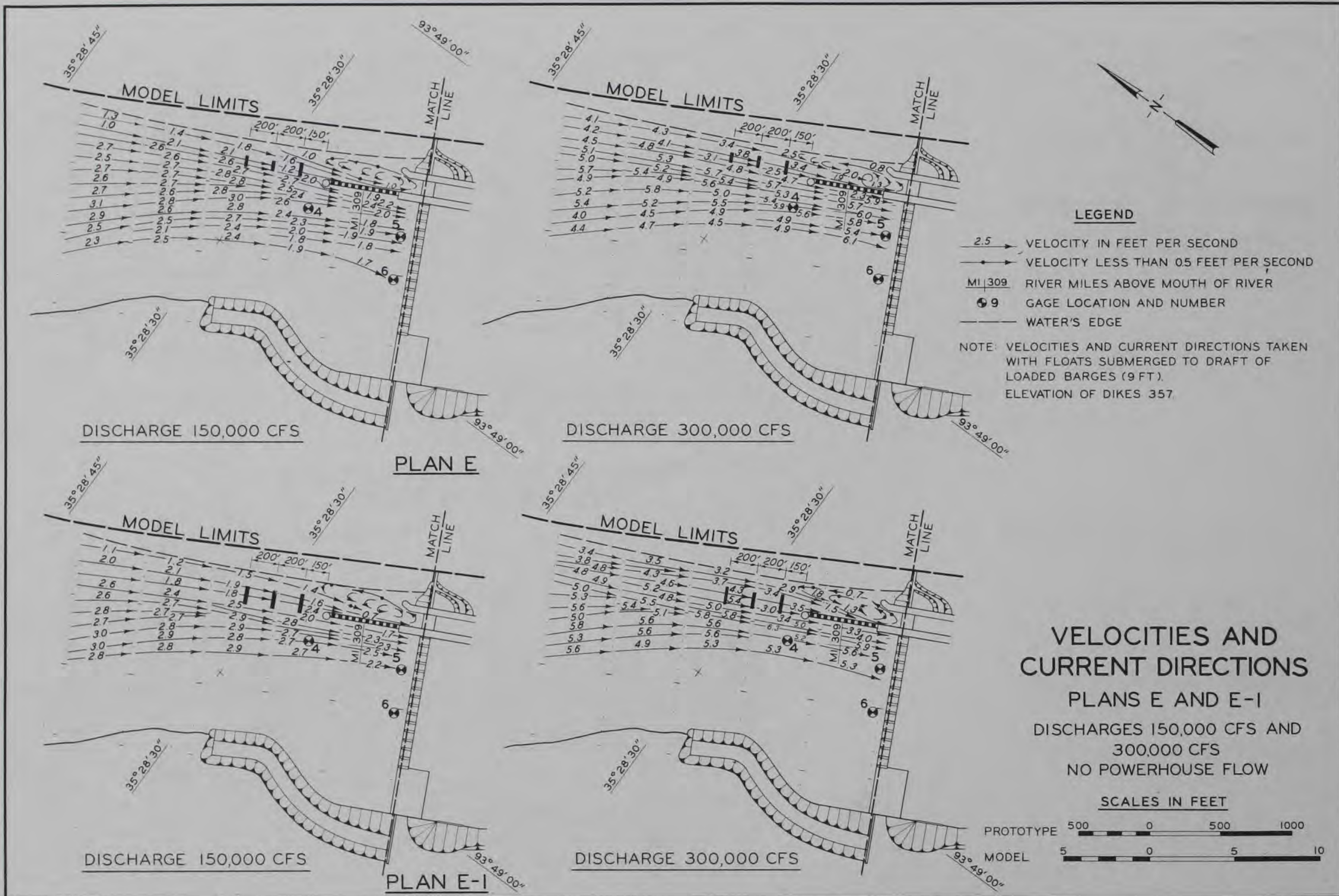

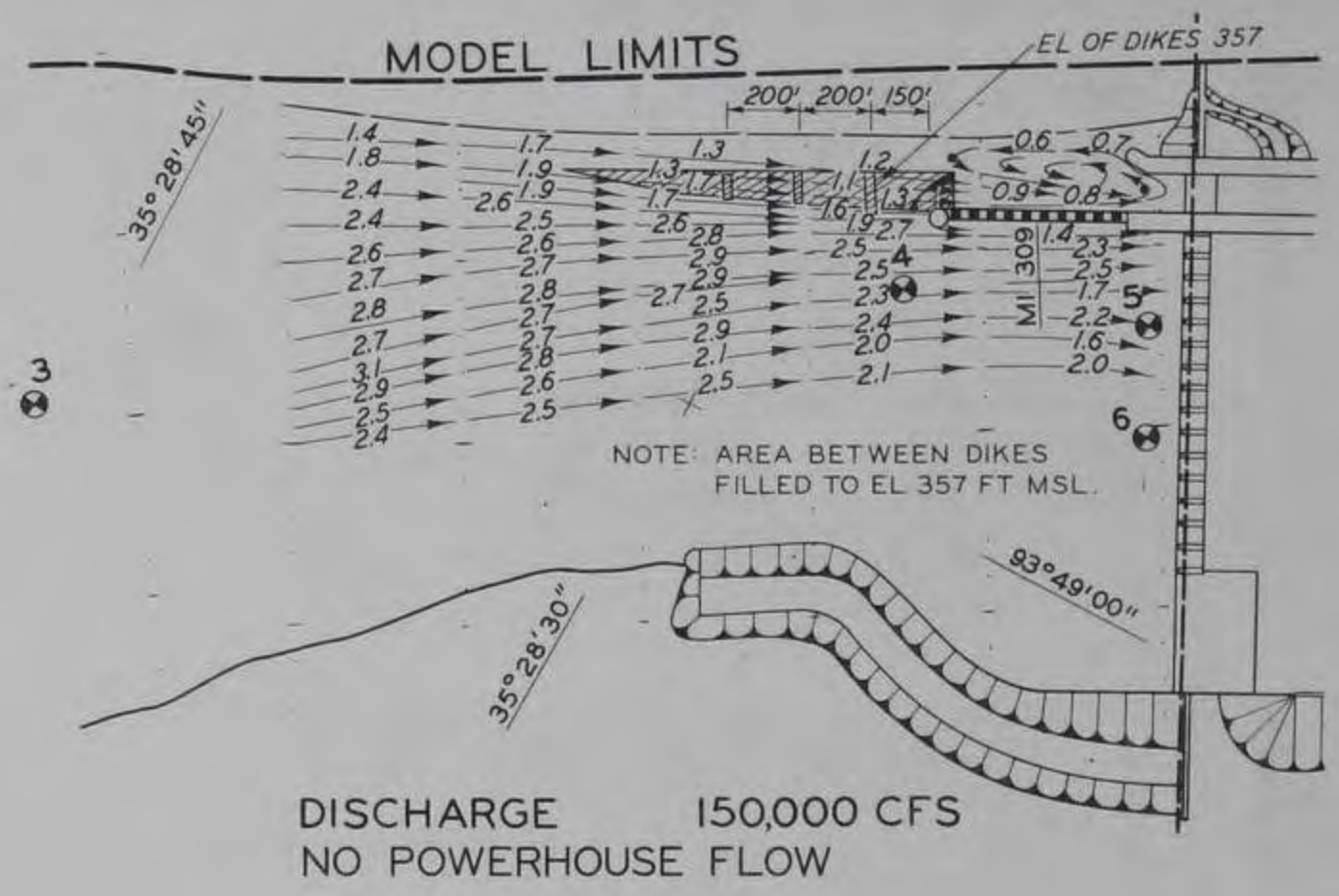
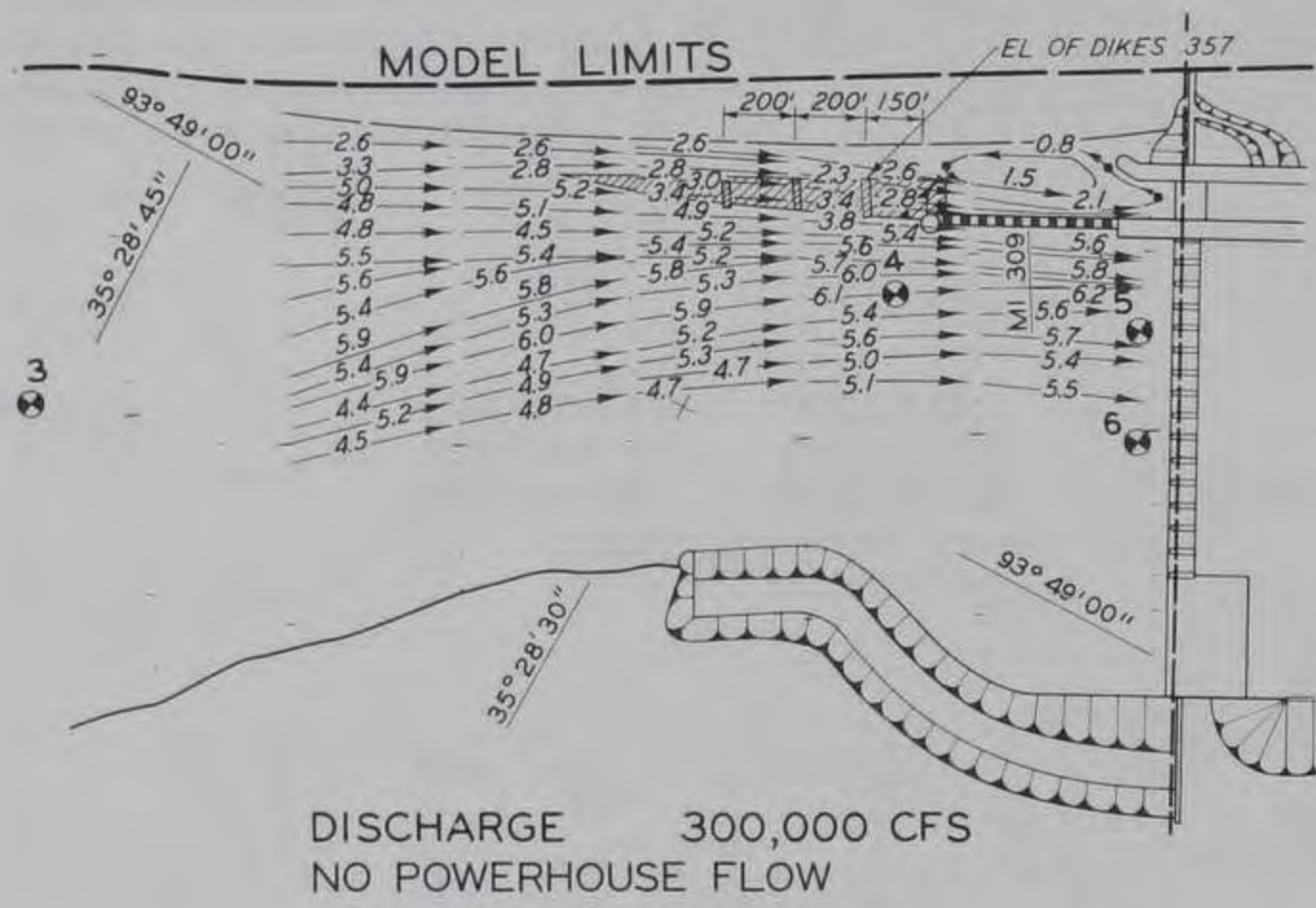

LEGEND

- ← 2.5 VELOCITY IN FEET PER SECOND
- ← 1.2 METER VELOCITY IN FEET PER SECOND
- ← VELOCITY LESS THAN 0.5 FEET PER SECOND
- MI 309 RIVER MILES ABOVE MOUTH OF RIVER
- NORMAL POOL

NOTE: VELOCITIES AND CURRENT DIRECTIONS TAKEN WITH FLOATS SUBMERGED TO DRAFT OF LOADED BARGES (9 FT).

**VELOCITIES AND
CURRENT DIRECTIONS**

PLAN E-2
DISCHARGES 150,000 AND
300,000 CFS

SCALES IN FEET



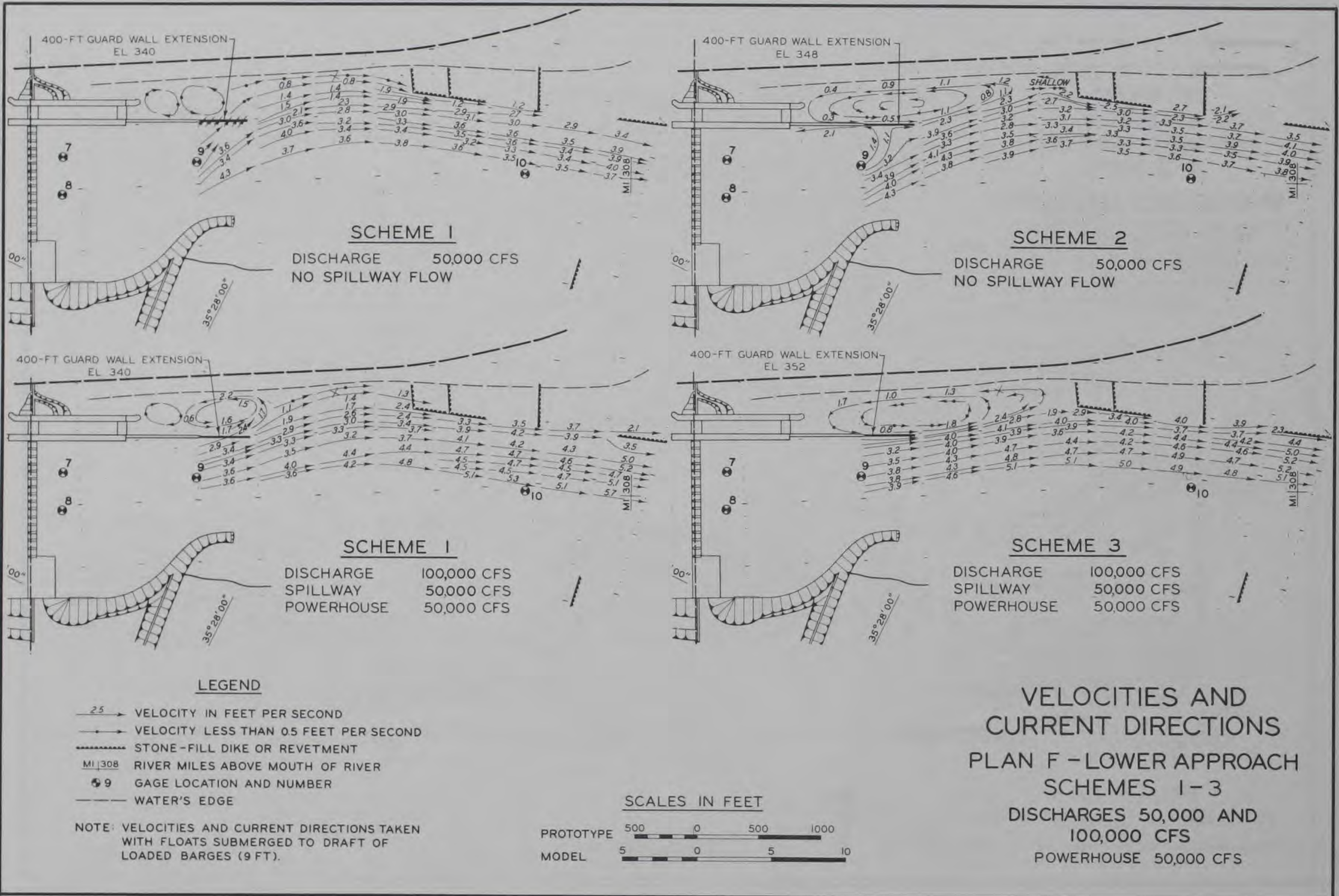

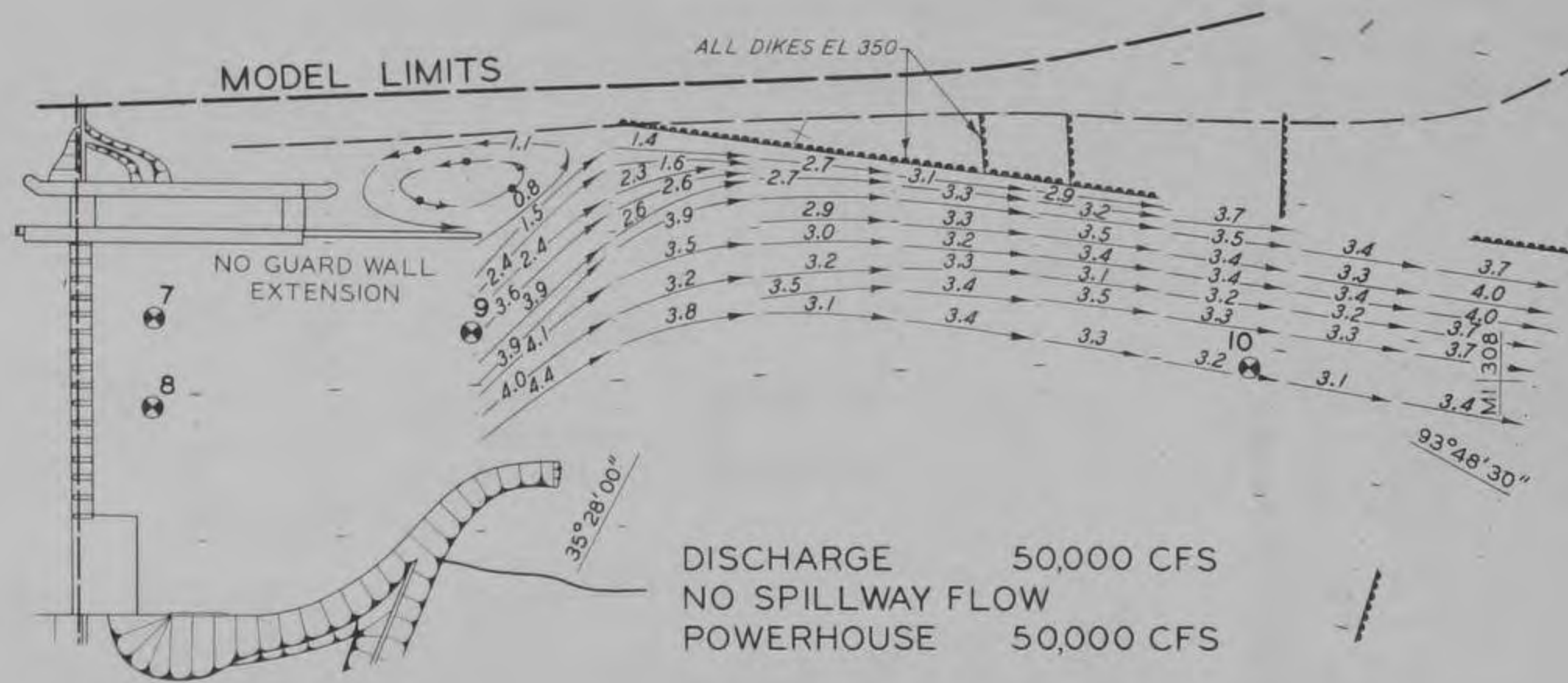

LEGEND

2.5 → VELOCITY IN FEET PER SECOND
 → VELOCITY LESS THAN 0.5 FEET PER SECOND
 --- STONE-FILL DIKE OR REVETMENT
 MI 309 RIVER MILES ABOVE MOUTH OF RIVER
 9 GAGE LOCATION AND NUMBER
 --- WATER'S EDGE

NOTE: VELOCITIES AND CURRENT DIRECTIONS TAKEN WITH FLOATS SUBMERGED TO DRAFT OF LOADED BARGES (9 FT).

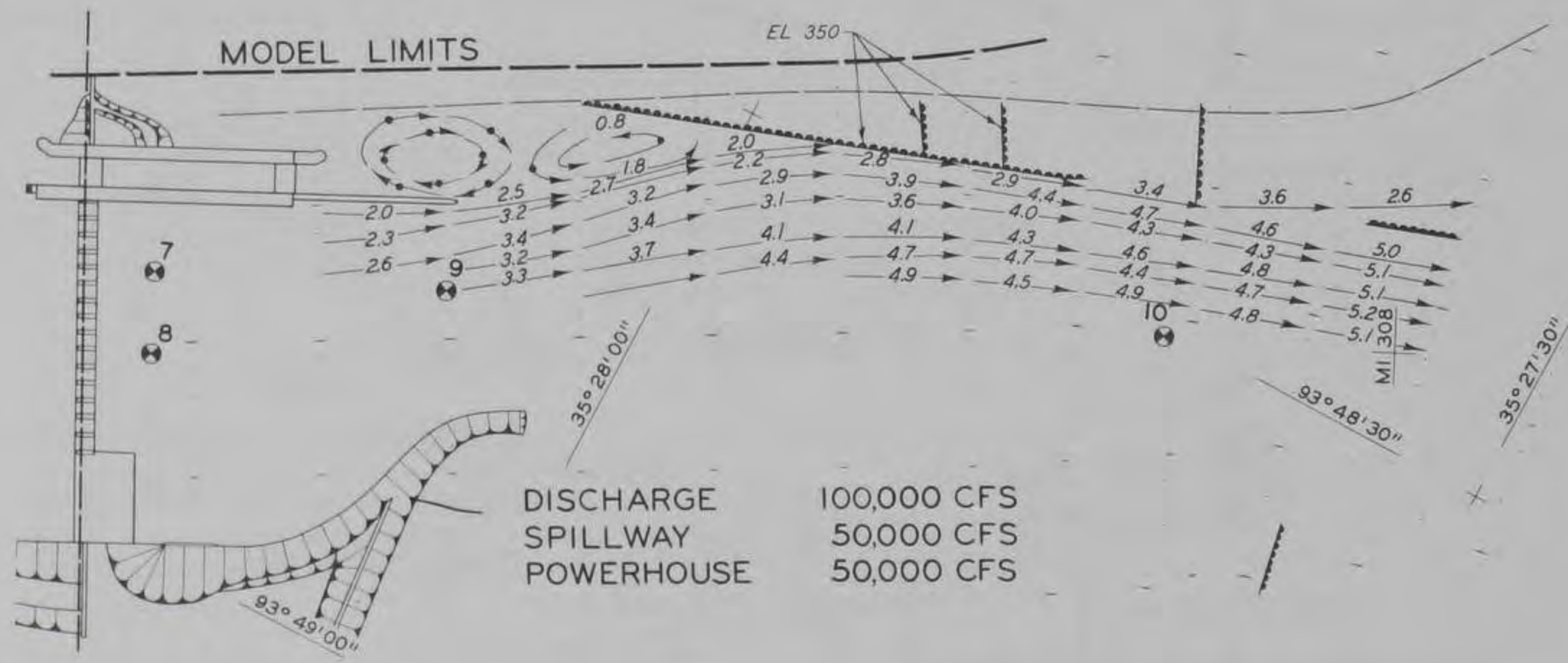

**VELOCITIES AND CURRENT DIRECTIONS
 PLAN F-LOWER APPROACH
 SCHEME 4
 DISCHARGES 50,000 AND 100,000 CFS
 SCALES IN FEET**



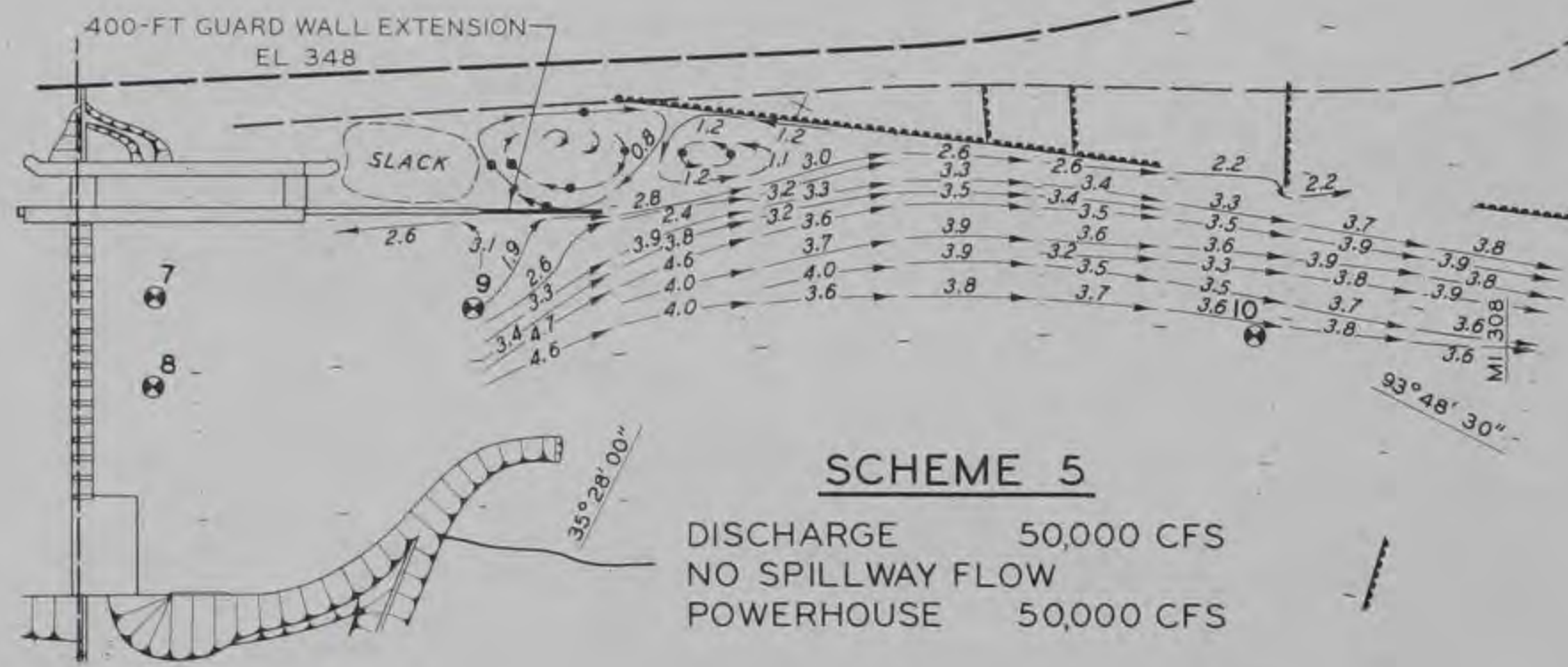

SCHEME 5

DISCHARGE 50,000 CFS
 NO SPILLWAY FLOW
 POWERHOUSE 50,000 CFS

LEGEND

- 2.5 → VELOCITY IN FEET PER SECOND
- VELOCITY LESS THAN 0.5 FEET PER SECOND
- STONE-FILL DIKE OR REVETMENT
- MI 308 RIVER MILES ABOVE MOUTH OF RIVER
- 9 GAGE LOCATION AND NUMBER
- WATER'S EDGE

NOTE: VELOCITIES AND CURRENT DIRECTIONS TAKEN WITH FLOATS SUBMERGED TO DRAFT OF LOADED BARGES (9 FT).

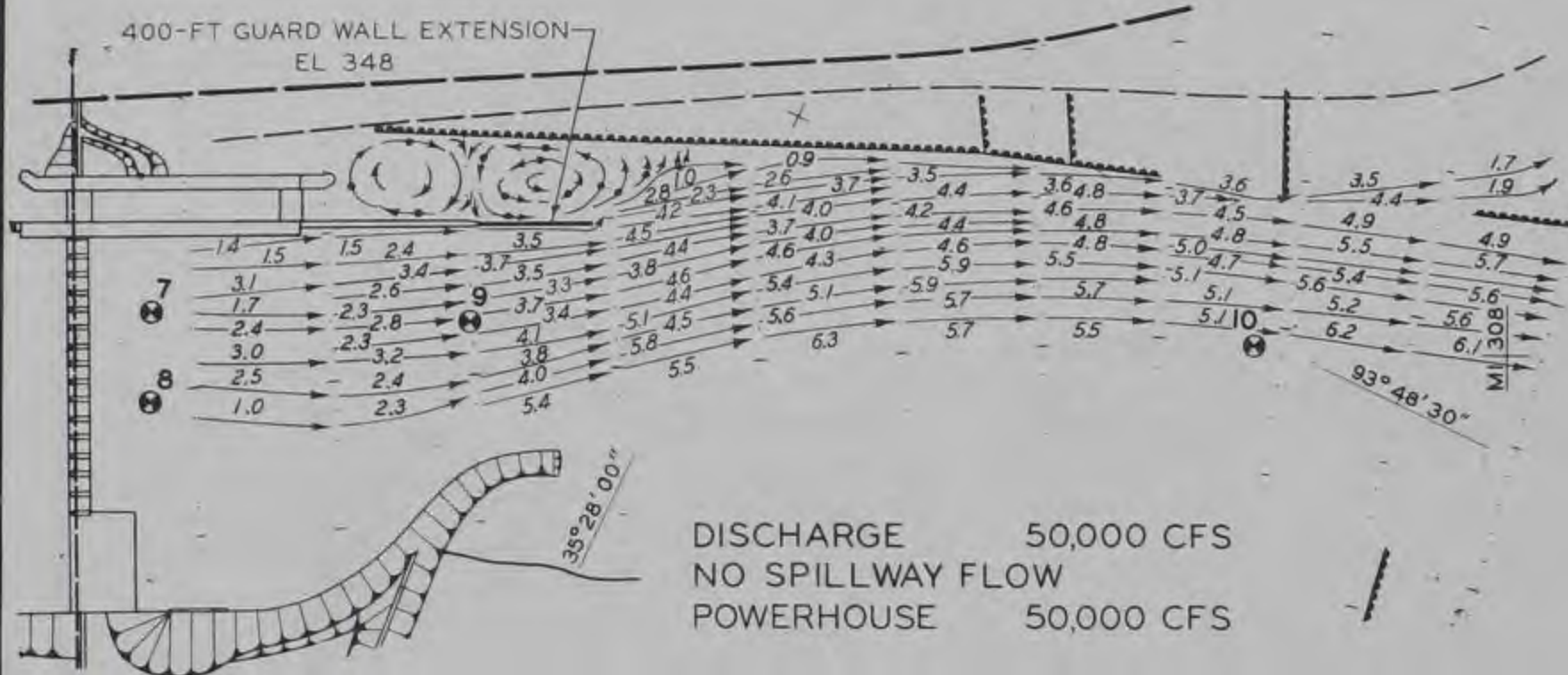

DISCHARGE 50,000 CFS
 NO SPILLWAY FLOW
 POWERHOUSE 50,000 CFS

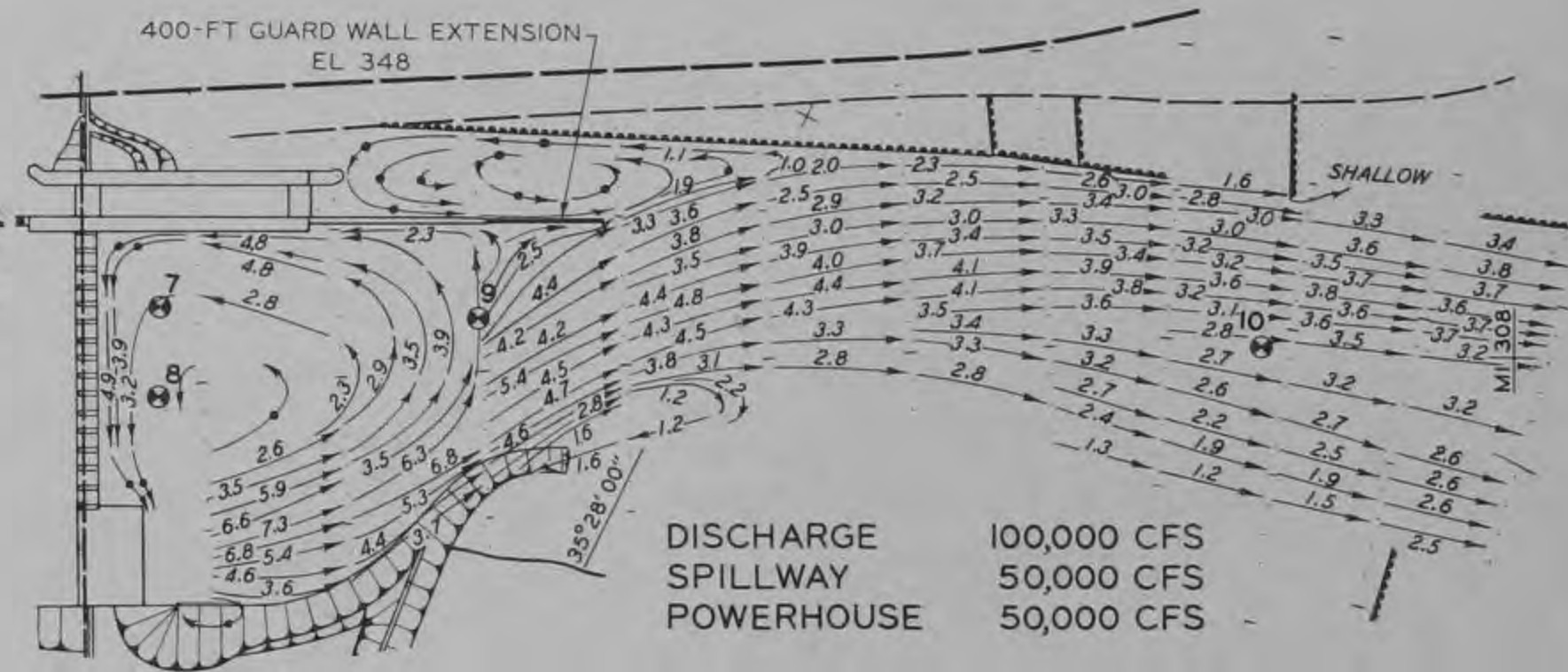

DISCHARGE 100,000 CFS
 SPILLWAY 50,000 CFS
 POWERHOUSE 50,000 CFS

SCHEME 6

SCALES IN FEET

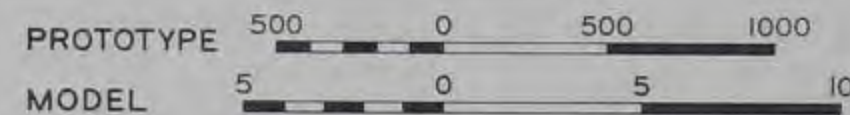

**VELOCITIES AND
 CURRENT DIRECTIONS
 PLAN F - LOWER APPROACH
 SCHEMES 5 AND 6
 DISCHARGES 50,000 AND
 100,000 CFS**



LEGEND

- 25 → VELOCITY IN FEET PER SECOND
- → VELOCITY LESS THAN 0.5 FEET PER SECOND
- STONE-FILL DIKE OR REVETMENT
- MI 308 RIVER MILES ABOVE MOUTH OF RIVER
- ⊙ 9 GAGE LOCATION AND NUMBER
- WATER'S EDGE

NOTE: VELOCITIES AND CURRENT DIRECTIONS TAKEN WITH FLOATS SUBMERGED TO DRAFT OF LOADED BARGES (9 FT).

SCALES IN FEET

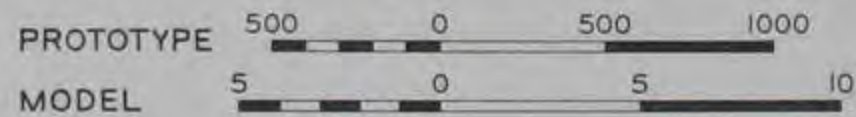

**VELOCITIES AND
CURRENT DIRECTIONS
PLAN F - LOWER APPROACH
SCHEMES 7-10**

DISCHARGE 300,000 CFS

SPILLWAY 250,000 CFS AND
POWERHOUSE 50,000 CFS

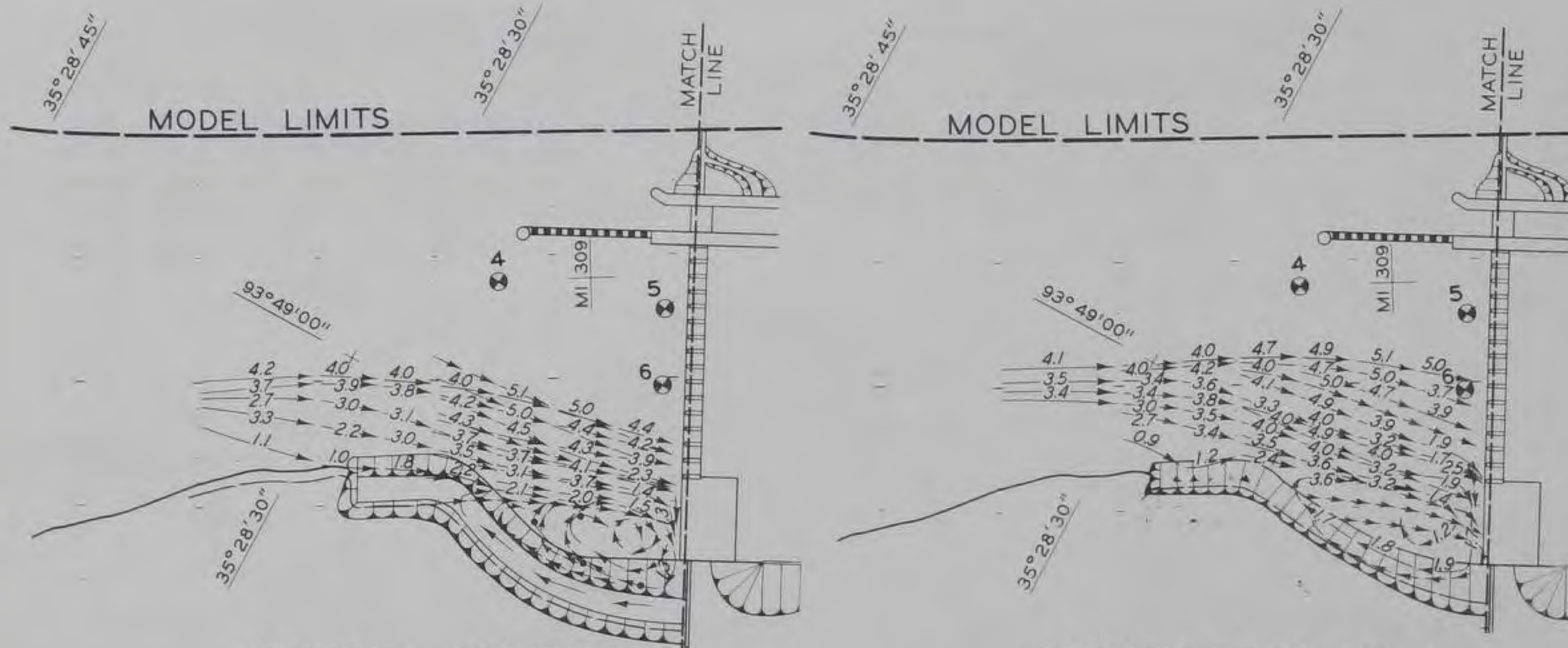

ORIGINAL DESIGN

MODIFICATION NO. 1

LEGEND

- 2.5 → VELOCITY IN FEET PER SECOND
- VELOCITY LESS THAN 0.5 FEET PER SECOND
- BOTTOM CURRENT DIRECTIONS
- STONE-FILL DIKE OR REVETMENT
- MI 309 RIVER MILES ABOVE MOUTH OF RIVER
- ⊙ 9 GAGE LOCATION AND NUMBER
- WATER'S EDGE

NOTE: VELOCITIES AND CURRENT DIRECTIONS TAKEN WITH FLOATS SUBMERGED TO DRAFT OF LOADED BARGES (9 FT.).

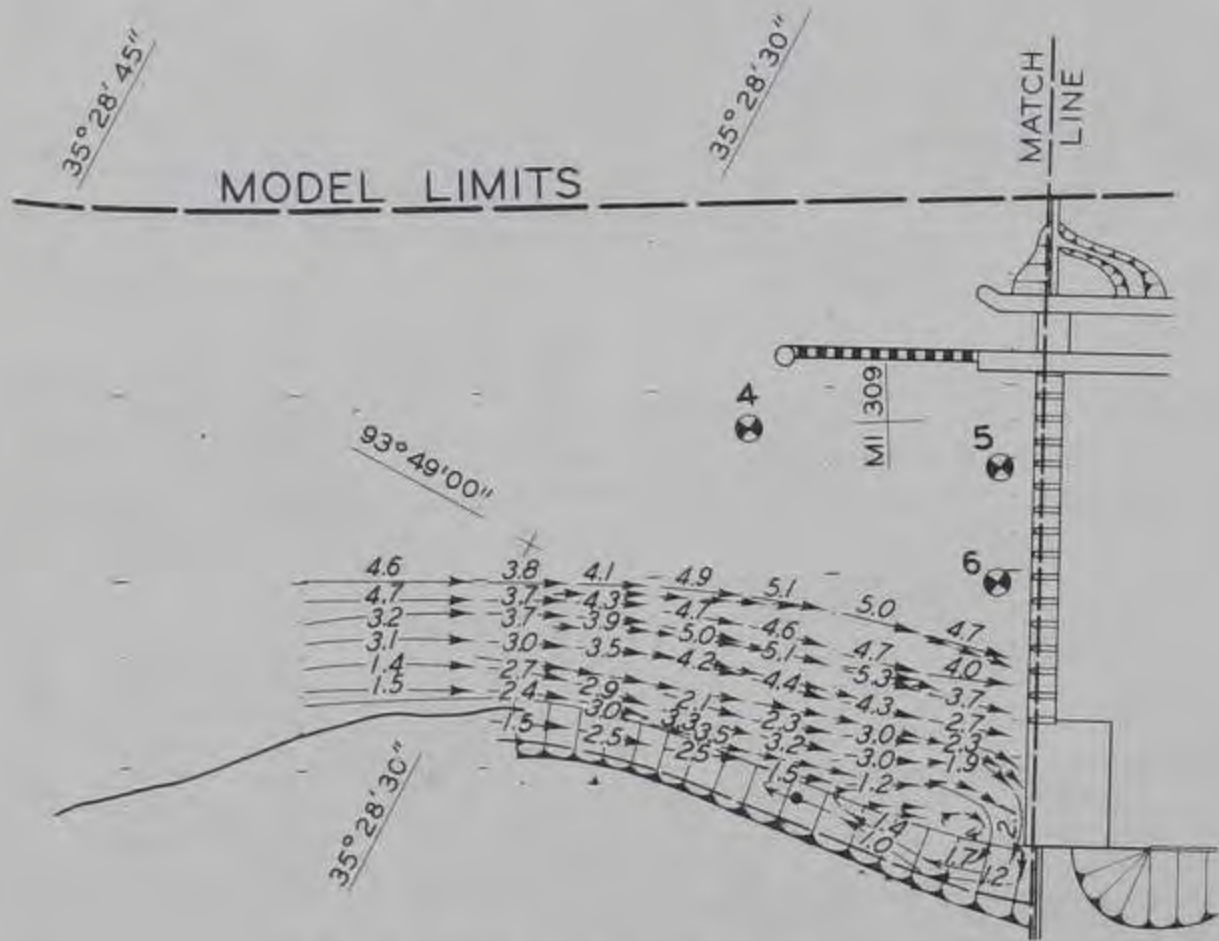

MODIFICATION NO. 2

VELOCITIES AND CURRENT DIRECTIONS

PLAN G

DISCHARGE 300,000 CFS
(POWERHOUSE 50,000 CFS)

SCALES IN FEET

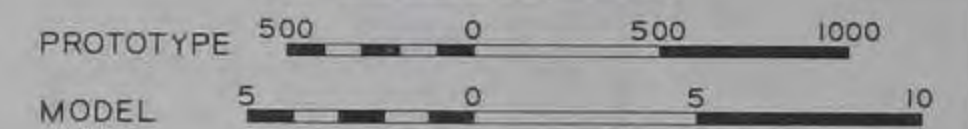

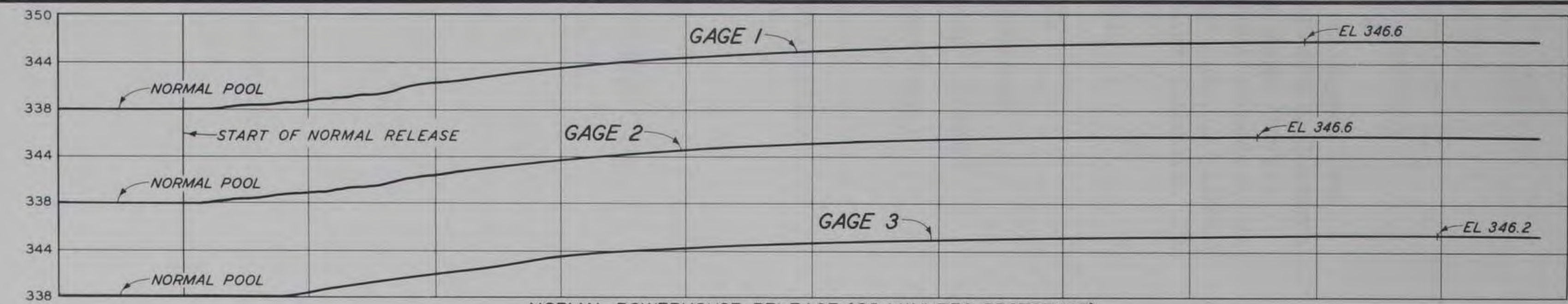

NORMAL POWERHOUSE RELEASE (25 MINUTES PROTOTYPE)
FLOW FROM 0 TO 50,000 CFS

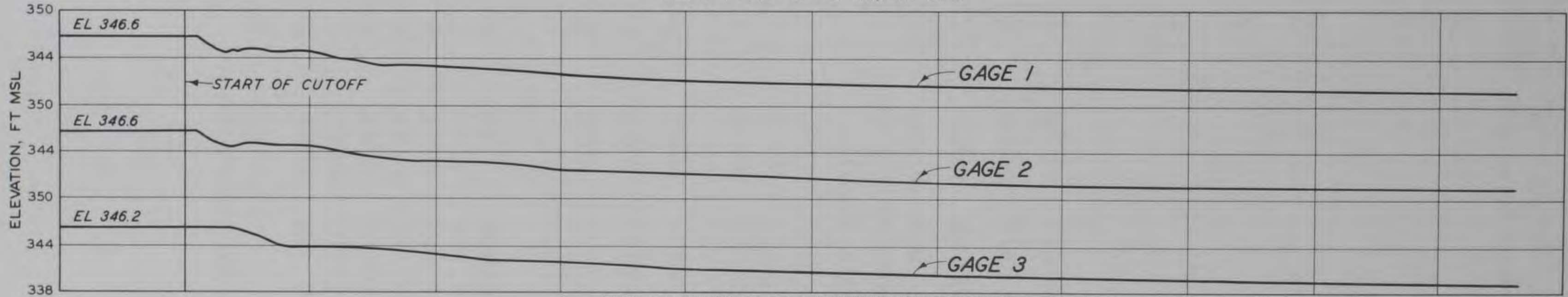

SUDDEN CUTOFF OF POWERHOUSE RELEASE
FLOW FROM 50,000 TO 0 CFS

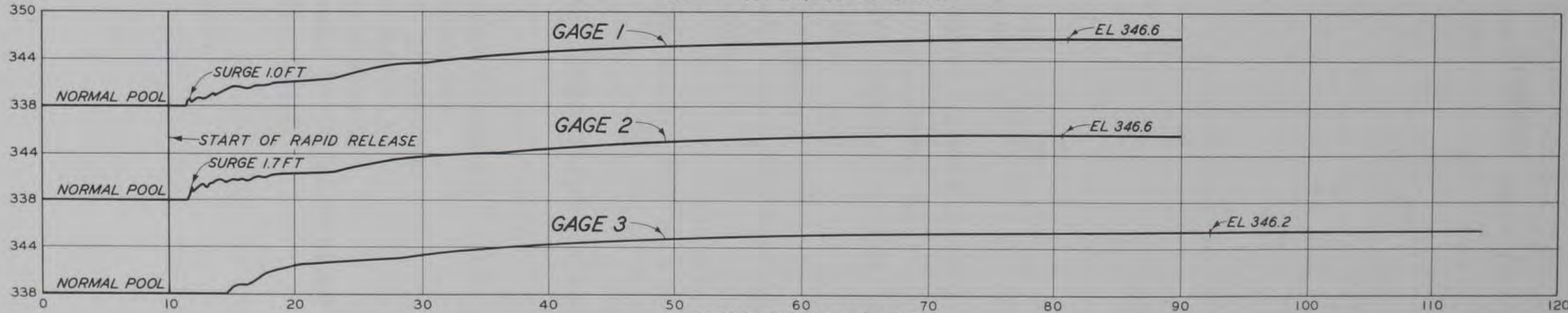

RAPID POWERHOUSE RELEASE (6 SECONDS PROTOTYPE)
FLOW FROM 0 TO 50,000 CFS

**SURGE MEASUREMENTS
POWERHOUSE RELEASE**

Unclassified

Security Classification

DOCUMENT CONTROL DATA - R & D

(Security classification of title, body of abstract and indexing annotation must be entered when the overall report is classified)

1. ORIGINATING ACTIVITY (Corporate author) U. S. Army Engineer Waterways Experiment Station Vicksburg, Mississippi		2a. REPORT SECURITY CLASSIFICATION Unclassified	
		2b. GROUP	
3. REPORT TITLE NAVIGATION CONDITIONS AT OZARK LOCK AND DAM, ARKANSAS RIVER; Hydraulic Model Investigation			
4. DESCRIPTIVE NOTES (Type of report and inclusive dates) Final report			
5. AUTHOR(S) (First name, middle initial, last name) John J. Franco Cody D. McKellar, Jr.			
6. REPORT DATE November 1968	7a. TOTAL NO. OF PAGES 95	7b. NO. OF REFS 0	
6a. CONTRACT OR GRANT NO.		9a. ORIGINATOR'S REPORT NUMBER(S) Technical Report H-68-10	
b. PROJECT NO.			
c.		9b. OTHER REPORT NO(S) (Any other numbers that may be assigned this report)	
d.			
10. DISTRIBUTION STATEMENT This document has been approved for public release and sale; its distribution is unlimited.			
11. SUPPLEMENTARY NOTES		12. SPONSORING MILITARY ACTIVITY U. S. Army Engineer District Little Rock, Arkansas	
13. ABSTRACT Ozark Lock and Dam will consist of a 110- by 600-ft lock and an 890-ft-long, gated, nonnavigable dam. A 1:120-scale, fixed-bed model, reproducing 2.7 miles of the Arkansas River, was used to: (a) demonstrate flow conditions in the lock approaches; (b) measure the distribution of flow across the model at the axis of the dam for a number of flows; and (d) assist in developing modifications of the approaches and structures to improve navigation conditions. Tests were concerned with the study of flow patterns, measurement of velocities in the lock approaches, and behavior of a model tow on entering and leaving the lock. The results of the investigation indicated the following: Modifications of the original design would be required to develop satisfactory navigation conditions in the lock approaches. Excavation for the entrance to the powerhouse can be reduced and flow distribution into the powerhouse can be improved by realignment of the upstream bankline. Sudden powerhouse releases could produce conditions hazardous to navigation and some limitation should be placed on the rate of increase in powerhouse discharge. The maximum head differential on the downstream lock gate during lock emptying could be as much as 0.6 ft during the higher flows.			

DD FORM 1473
1 NOV 65

REPLACES DD FORM 1473, 1 JAN 64, WHICH IS OBSOLETE FOR ARMY USE.

Unclassified

Security Classification

14.	KEY WORDS	LINK A		LINK B		LINK C	
		ROLE	WT	ROLE	WT	ROLE	WT
	Arkansas River						
	Dams, Navigation						
	Hydraulic models						
	Locks						
	Navigation conditions						
	Ozark Lock and Dam						