



Technical Report HL-96-15
April 1996

TA7
W34
no. HL-96-15
c. 3

Corps
Engineers
Experiment Station

US-CE-C Property of the
United States Government

Grade Control Structure for Blue River, Kansas City, Missouri

by Deborah R. Cooper

WES

Approved For Public Release; Distribution Is Unlimited

Research Library
US Army Engineer Waterways
Experiment Station
Vicksburg, Mississippi

Prepared for U.S. Army Engineer District, Kansas City

34672711

TAF
W34
no. HL-96-15
c.3

Technical Report HL-96-15
April 1996

Grade Control Structure for Blue River, Kansas City, Missouri

by Deborah R. Cooper

U.S. Army Corps of Engineers
Waterways Experiment Station
3909 Halls Ferry Road
Vicksburg, MS 39180-6199

Final report

Approved for public release; distribution is unlimited

Prepared for U.S. Army Engineer District, Kansas City
Kansas City, MO 64106-2896



**US Army Corps
of Engineers**
Waterways Experiment
Station



Waterways Experiment Station Cataloging-in-Publication Data

Cooper, Deborah R.

Grade control structure for Blue River, Kansas City, Missouri / by Deborah R. Cooper ; prepared for U.S. Army Engineer District, Kansas City.

220 p. : ill. ; 28 cm. — (Technical report ; HL-96-15)

Includes bibliographical references.

1. Blue River (Mo.) 2. Hydraulic structures — Missouri — Blue River. 3. Weirs — Missouri — Blue River. I. United States. Army. Corps of Engineers. Kansas City District. II. U.S. Army Engineer Waterways Experiment Station. III. Hydraulics Laboratory (U.S. Army Engineer Waterways Experiment Station) IV. Title. V. Series: Technical report (U.S. Army Engineer Waterways Experiment Station) ; HL-96-15.

TA7 W34 no.HL-96-15

Contents

Preface	iv
1—Introduction	1
The Prototype	1
Purpose and Scope of the Model Study	3
Presentation of Data	4
2—The Model and Experiment Procedure	5
Description	5
Appurtenances and Instrumentation	5
Scale Relations	5
Experiment Procedure	10
3—Experiments and Results	11
Discharge Characteristics	11
Swopes Park Flow	12
Weir Experiments	14
Confined Flow Experiments	18
Velocities at Byram's Ford	19
Debris Deflector Experiments	20
Stilling Basin Experiments	20
Riprap Requirements	20
Left Trail Levee Experiments	21
Overbank Flow Experiments	22
Breached Spoil Bank Experiments	22
4—Conclusions	23
Tables 1-112	
Photos 1-15	
Plates 1-62	

Preface

The investigation reported herein was authorized by Headquarters, U.S. Army Corps of Engineers (HQUSACE), on 9 December 1992 at the request of the U.S. Army Engineer District, Kansas City.

The studies were conducted in the Hydraulics Laboratory (HL) of the U.S. Army Engineer Waterways Experiment Station (WES) during the period January 1993 to May 1994 under the direction of Messrs. F. A. Herrmann, Jr., Director, HL; R. A. Sager, Assistant Director, HL; and G. A. Pickering, Chief of the Hydraulic Structures Division (HSD), HL. The studies were conducted by Dr. J. E. Hite of the Locks and Conduits Branch, HSD, and Mrs. D. R. Cooper, Mr. R. Bryant, Jr., Mr. E. L. Jefferson, Mr. D. N. Mobley, and Mr. D. M. White of the Spillways and Channels Branch, HSD, under the direct supervision of Mr. N. R. Oswalt, Chief of the Spillways and Channels Branch. This report was prepared by Mrs. Cooper.

During the course of the investigation Messrs. J. Grasso, D. Hokens, W. Mellema, and A. Swoboda of the U. S. Army Engineer Division, Missouri River (CEMRD); B. Buchholz of the U. S. Army Engineer District, Omaha (CEMRO); and M. Bart, J. Conley, J. Lilley, K. Low, B. Pearce, and B. Ziegler of the U. S. Army Engineer District, Kansas City (CEMRK), visited WES to discuss study results and correlate these results with current design studies.

Mr. Joe Lyons, Engineering and Construction Services Division, WES, constructed the control structure. The following craftsmen, also of Engineering and Construction Services Division, molded overbank contours and river contours in the model: Messrs. Dan Barnes, Dennis Beausoliel, Charles Brown, Herman Brown, Clarence Drayton, Carl Gaston, Arnold Taylor, Willie Thomas, Stacey Washington, and Charles Wilson.

During the preparation and publication of this report, Dr. Robert W. Whalin was Director of WES. COL Bruce K. Howard, EN, was Commander.

The contents of this report are not to be used for advertising, publication, or promotional purposes. Citation of trade names does not constitute an official endorsement or approval of the use of such commercial products.

1 Introduction

The Prototype

This report describes model studies and results for a portion of the flood-control plan for Stage III of the Blue River Flood Protection Project. The Blue River, Kansas City, MO,—frequently referred to as the Big Blue River to distinguish it from the neighboring Little Blue River—is a right-bank tributary of the Missouri River (Figure 1). The project consists of improving the existing channel from its confluence with the Missouri River upstream for approximately 12 river miles.

A major portion of the project is in a highly congested industrial area with numerous street, highway, and railroad bridges. The channel improvements were designed to contain a discharge of 991 cu m/sec (35,000 cfs) with a coincident 10-year-frequency flood on the Missouri River. This design discharge of 991 cu m/sec (35,000 cfs) approximates a 30-year-frequency flood. A grade control structure near sta 99+60 is the only major concrete structure planned as part of Stage III of the channel improvements.

The structure will be located downstream of Byram's Ford (sta 113+50) where it will not adversely impact the historic ford. The ford and associated Big Blue Battleground, a Civil War historic area, was nominated to the National Register of Historic Places in October of 1989. The headwater elevations for the grade control structure were originally developed to allow a drawdown in the existing channel corresponding to a 5 percent differential in velocity upstream. A three-stage weir design, shown in Plate 1, was necessary to provide acceptable velocities at all stages of flood flow. The lower stage of the weir had a crest elevation of 732.0¹ (approach channel elevation) and a weir length of 3 m (10 ft). The lower stage of the weir was designed to prevent upstream ponding and sediment deposition at normal flows. The middle stage had a weir crest elevation of 750.0 and a weir length of 30 m (97 ft). The upper stage had a weir crest elevation of 764.0 and a weir length

¹ All elevations (el) and stages cited herein are in feet referred to the National Geodetic Vertical Datum (NGVD). To change elevations to meters, multiply by 0.3048.

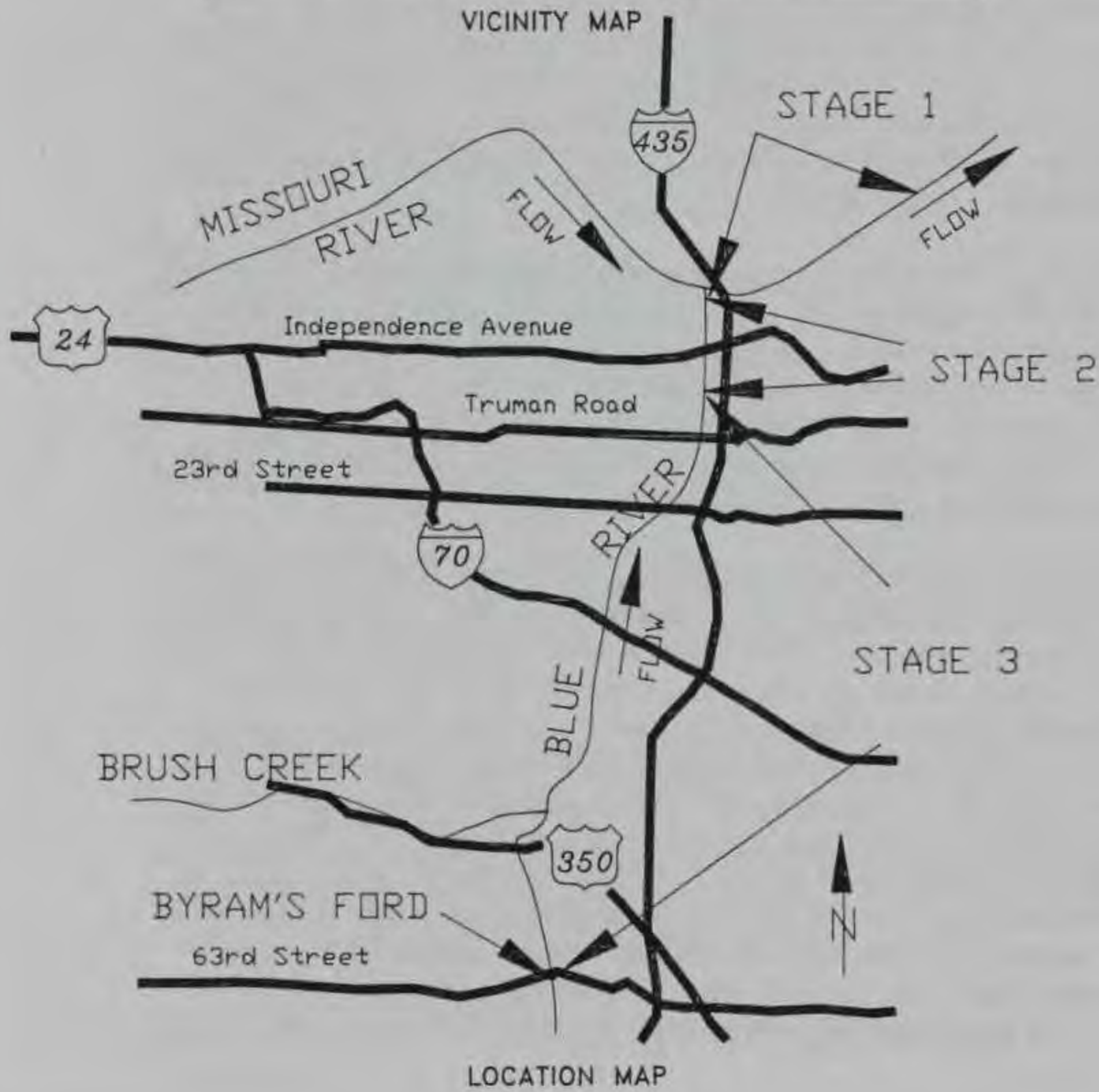

Figure 1. Vicinity and location maps

of 16 m (53 ft). The total length of the weir was 49 m (160 ft). Energy was dissipated with a horizontal apron with baffle blocks terminated by an end sill. Design water-surface elevations for the existing and modified channels at the proposed location of the grade control structure are 774.0 and 759.8 (cut-off alignment), respectively. The grade control structure was required to minimize the erosion that would result from the high velocities at the upstream end of the improved channel where the unmodified channel begins.

Purpose and Scope of the Model Study

An investigation was made of the Byram's Ford Industrial Park area to determine the feasibility of providing flood protection to the area. The study addressed both 50-year and 100-year floods on the Blue River. The main purpose of the study was to determine what level of flood protection could be provided in the Byram's Ford Industrial Park area without adversely affecting the cultural values of the historic battlefield site. The feasibility of placing a "spoil bank" to protect the industrial park was coordinated among the U.S. Army Engineer District, Kansas City; the City of Kansas City; the Civil War Round Table; and the Byram's Ford Industrial Park landowners. The "spoil bank" was defined by the Kansas City District as an earthen barrier constructed using soil excavated from the channel during channel improvements.

The design for channel improvement of the Blue River was in accordance with sound engineering procedures; however, a model study was considered essential to reproduce the natural channel rating curve, examine the significant energy dissipation problems expected downstream of the grade control structure, and determine the impact of the drop structure on velocities and flow conditions at the Byram's Ford Civil War Crossing. The model study was necessary to ensure the integrity of the channel design while attempting to minimize the real estate requirements by the city of Kansas City. The physical model was also needed to verify the hydraulics of the proposed stilling basin design. With multiple weir elevations, flow conditions across the basin are not uniform. The following information was obtained from the model:

- a.* Flow characteristics and stilling basin performance with flow over the drop structure and the left overbank.
- b.* Flow characteristics and stilling basin performance with all flow confined to the channel and passing over the structure.
- c.* Relative degree of turbulence (as shown by dye) observed visually in the stilling basin and exit channel.
- d.* Riprap requirements for protection upstream and downstream of the structure.
- e.* Flow conditions at Byram's Ford and Byram's Ford Industrial Park with a breach in the earth barrier.

- f.* Preservation and deviation of channel velocities with drop structure in place, modifications thereto, and for other modeled flood events.

Presentation of Data

In the presentation of experiment results, the data are not discussed in the chronological order in which the experiments were conducted on the model. Instead, as each element of the structure is considered, all experiments conducted thereon are discussed in detail. All model data are presented in terms of prototype equivalents. All experiments are discussed in Part 3 of this report.

2 The Model and Experiment Procedure

Description

Originally the 1:36-scale model (Figures 2 and 3, Plates 1-3) reproduced an approach area 716 m (2,350 ft) wide extending 701 m (2,300 ft) upstream from the weir and an exit area 716 m (2,350 ft) wide extending 244 m (800 ft) downstream from the weir, the 63rd Street bridge, the spoil bank, Byram's Ford Industrial Park, the three-stage weir, and the 42-m- (137-ft-) long stilling basin, and basin elements. The weir section, stilling basin, and basin elements were constructed of plastic and wood. The portions of the model representing the approach channel and overbank areas were molded in concrete and the exit channel was molded in sand and gravel. The buildings in Byram's Ford Industrial Park were built of plywood. The original design weir is referred to as the type 1 (original) design (Plate 1).

Appurtenances and Instrumentation

Water used in the operation of the model was supplied by pumps, and discharges were measured with venturi meters. The tailwater in the downstream end of the model was controlled by an adjustable tailgate. Water-surface elevations were obtained with point gages mounted on tripods. Velocities were measured with a Nixon 402 digital flowmeter.

Scale Relations

The accepted equations of similitude, based upon the Froudian relations, were used to express the mathematical relations between the dimensions and hydraulic quantities of the model and the prototype. General relations for the

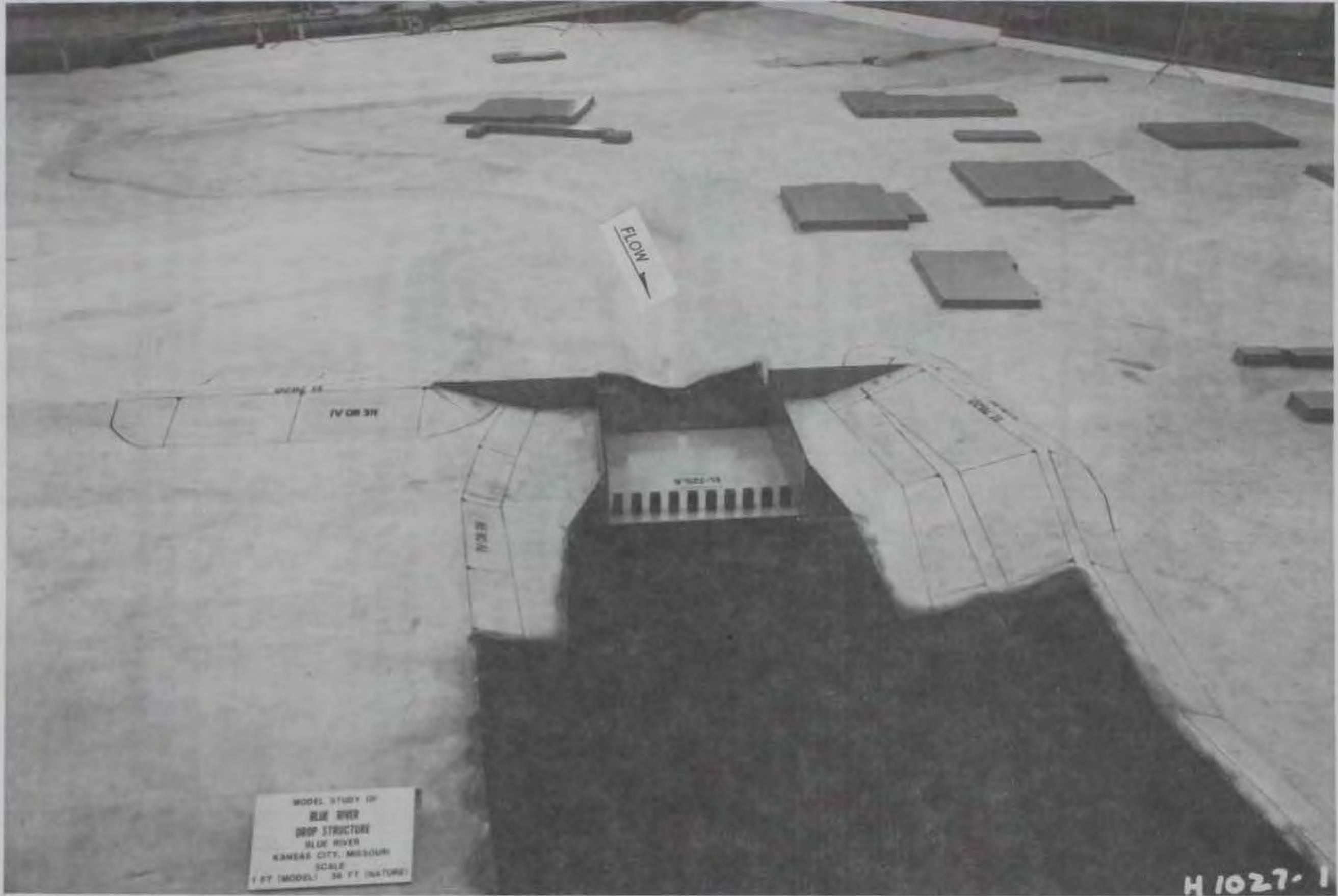

a. Looking upstream

Figure 2. 1:36-scale model (Continued)

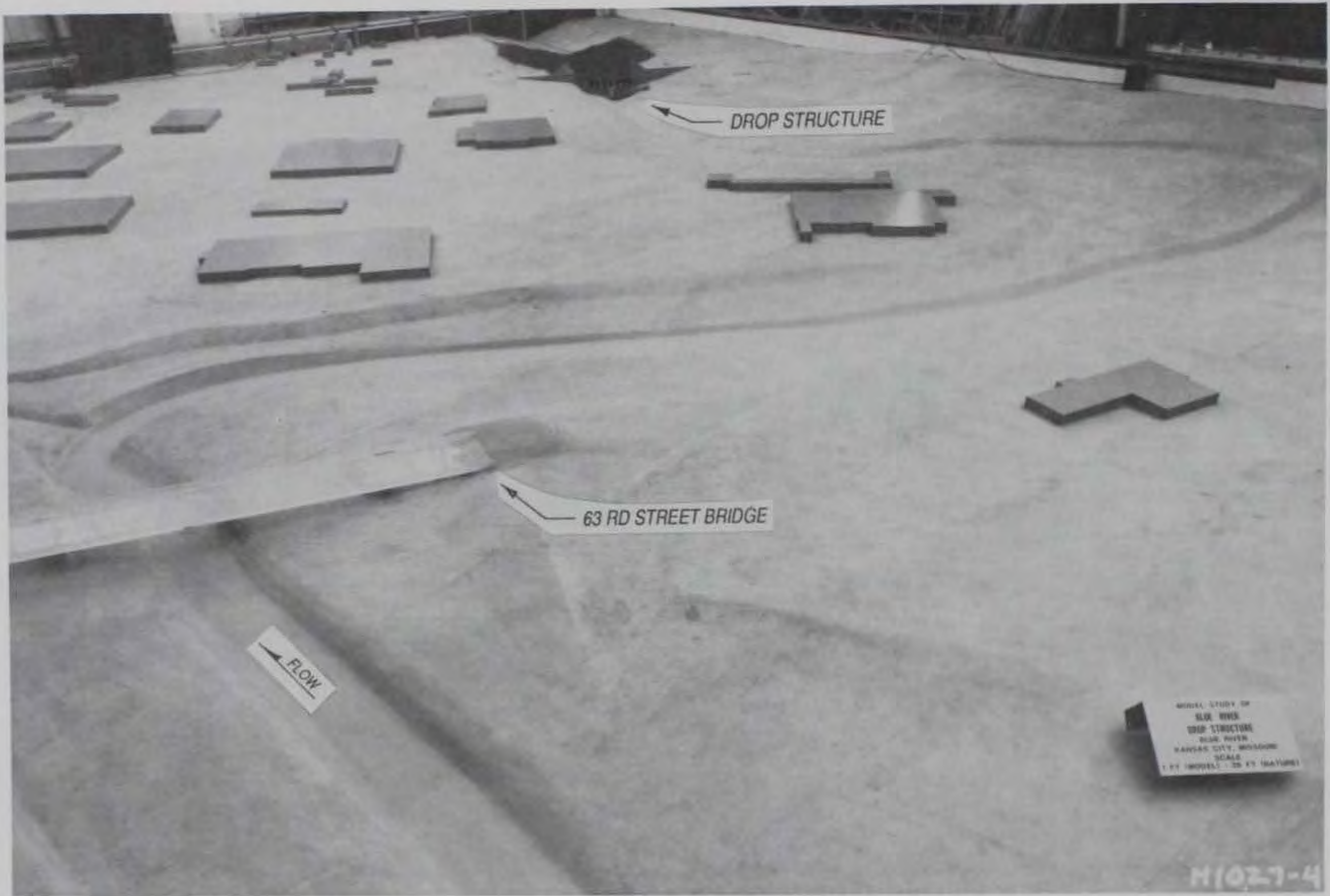

b. Looking downstream

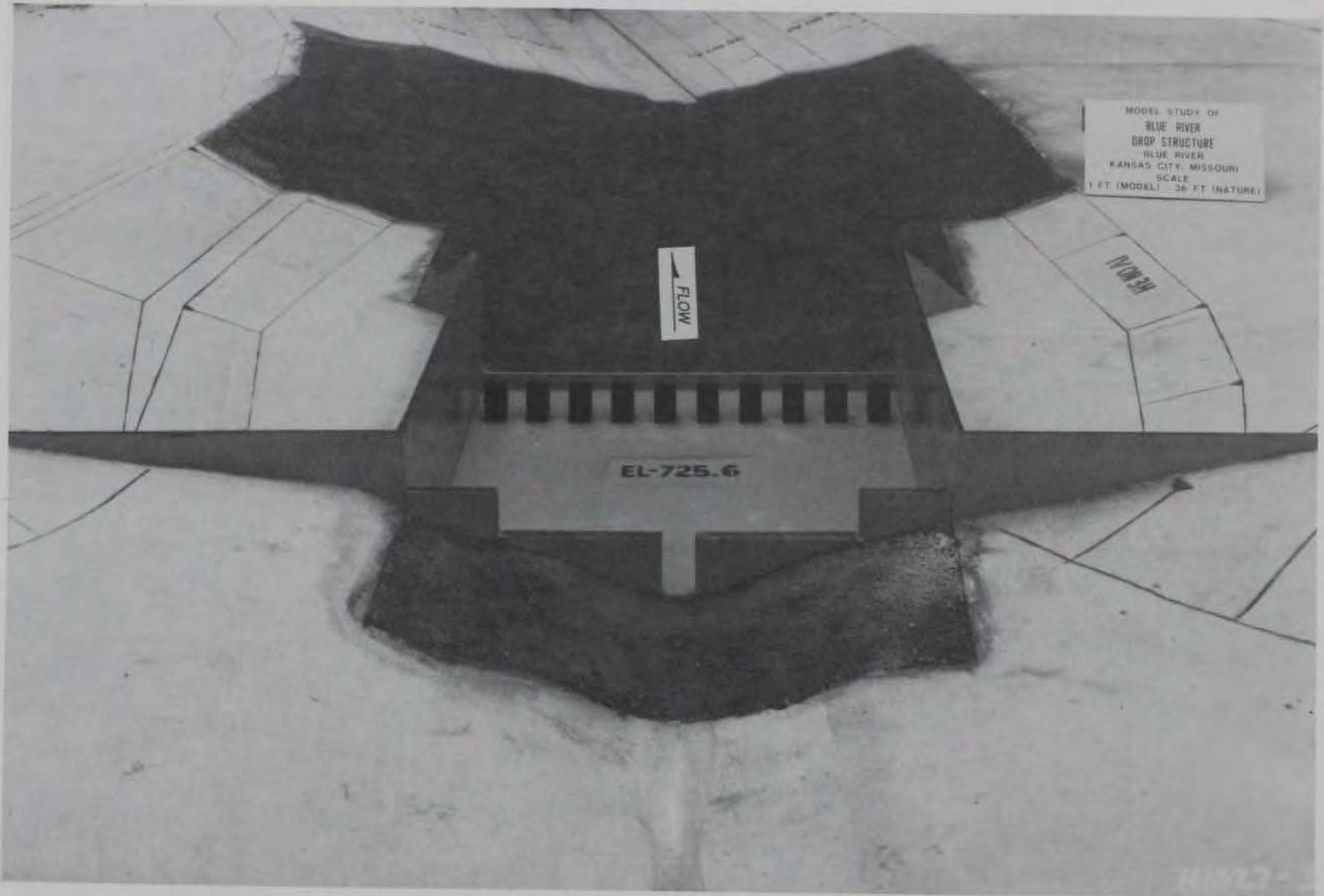

a. Looking downstream

Figure 3. Original drop structure (Continued)

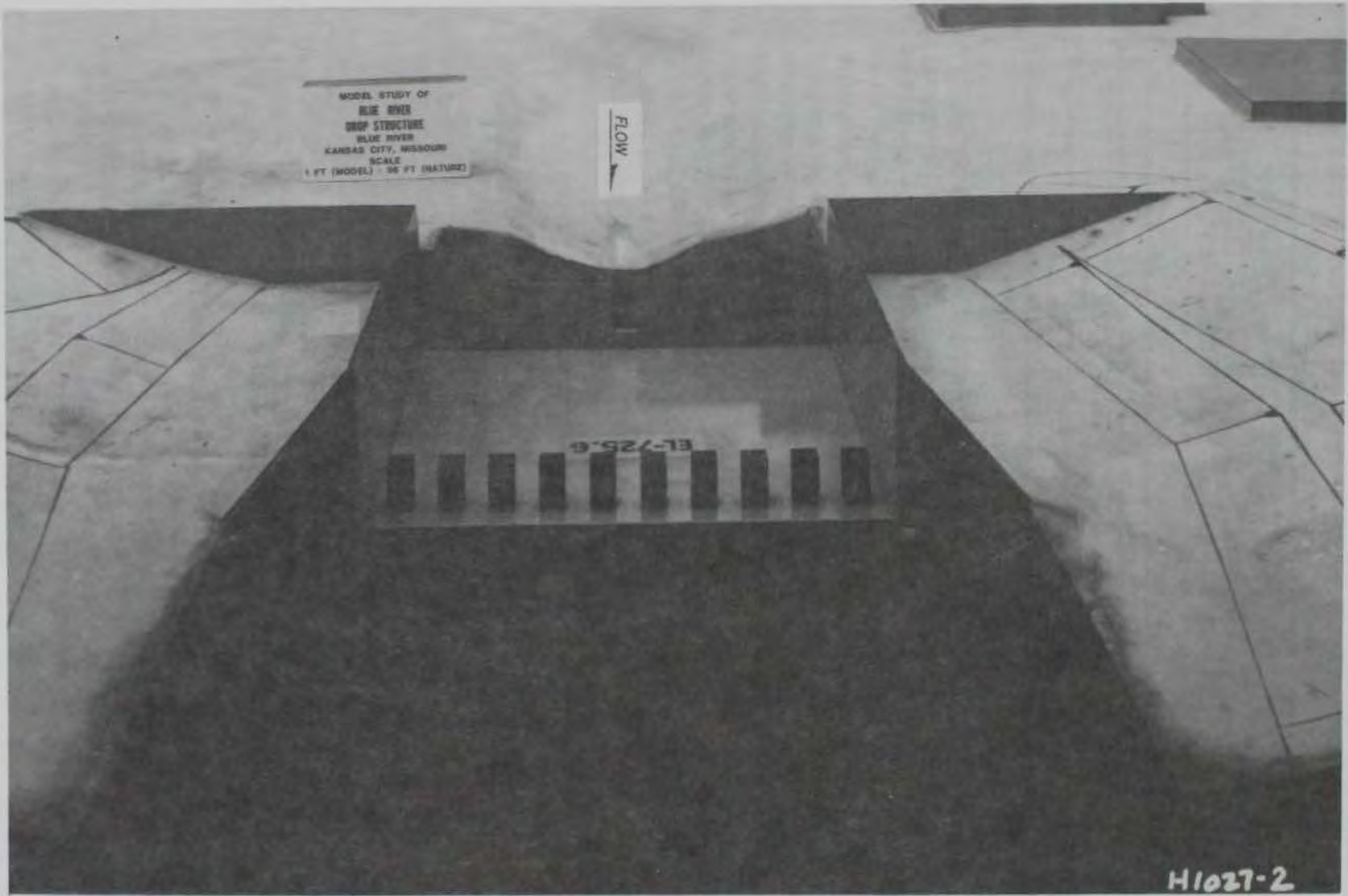

b. Looking upstream

6 Figure 3. (Concluded)

transference of model data to prototype equivalents are presented in the following tabulation:

Dimension	Ratio	Scale Relations Model:Prototype
Length	$L_r = L$	1:36
Area	$A_r = L_r^2$	1:1,296
Velocity	$V_r = L_r^{1/2}$	1:6
Discharge	$Q_r = L_r^{5/2}$	1:7,776
Time	$T_r = L_r^{3/2}$	1:6

Because of the nature of the phenomena involved, certain of the model data can be accepted quantitatively, while other data are reliable only in a qualitative sense. Measurements in the model of discharges, water-surface elevations, velocities, and resistance to displacement of riprap material can be transferred quantitatively from model to prototype by means of these scale relations. Evidence of scour of the model sand bed, however, is to be considered only as qualitatively reliable since it has not yet been found possible to reproduce quantitatively in a model the relative extent of erosion that occurs in the prototype. Data on scour tendencies provided a basis for determination of the relative effectiveness of the different designs and indicated the areas most subject to degradation and deposition.

Experiment Procedure

Experiments were conducted in the model to observe the flow patterns, velocities, discharges, and overall hydraulic performance of the drop structure. Various constant discharges were introduced into the model, the tailwater was set, and the river was allowed to stabilize. Sufficient time was allowed for stabilization of the river upstream of the structure. Water-surface elevations were measured at various stations along the river as shown in Plate 2. Tailwater elevations were measured at a point 81 ft downstream from the end sill (sta 97+02.5). The tailwater rating curve used in these experiments is shown in Plate 4. Water-surface profile elevations and velocities were measured in the river as well as in the left overbank.

3 Experiments and Results

Discharge Characteristics

The Kansas City District provided computed step backwater water-surface elevations without spoil banks and the drop structure in place throughout the study area for discharges up to 2,265 cu m/sec (80,000 cfs). Initial experiments were conducted to document water-surface elevations without the drop structure and without roughness materials (trees, brush, etc.) in the model to determine the extent of roughness materials that would be needed to reproduce the computed water-surface elevations. The water-surface elevation at sta 102+00 was set with the tailgate, and measurements were then obtained for stations upstream of sta 102+00. The results from these experiments are shown in Tables 1-9. The discharges ranged from 28 to 2,265 cu m/sec (1,000 to 80,000 cfs), and results indicated that significant roughness had to be added in the model for discharges greater than 283 cu m/sec (10,000 cfs). Plots comparing the computed water-surface profile with the water-surface profile measured in the model for 283, 849, and 2,265 cu m/sec (10,000, 30,000 and 80,000 cfs) are shown in Plates 5-7.

The experiments also showed that for discharges greater than 566 cu m/sec (20,000 cfs), overbank flow began to enter the river near sta 120+15. The entire flow was routed down the river for the District-computed water-surface elevations, which did not account for flow reentering the river at this location. This caused the computed water-surface elevations to be higher for the large overbank flows (>991 cu m/sec (35,000 cfs)) than would actually exist. The Kansas City District indicated that the roughness material should be added to the model to match the computed water-surface elevations for discharges up to 991 cu m/sec (35,000 cfs) and that the computed values greater than 991 cu m/sec (35,000 cfs) should be disregarded.

Experiments were conducted next with roughness material added in the model in an attempt to match the computed water-surface elevations. A screen wire material was placed on the channel bottom to produce the appropriate roughness for flows contained in the channel (flows up to 283 cu m/sec (10,000 cfs)). A porous rubberized material (commonly referred to as horsehair) was used to produce the desired roughness on the overbanks. Masonry bricks were used to hold this material in place. An aerial

photograph furnished by the Kansas City District showed locations of heavy tree growth. The roughness material was placed in the model in the locations to match the heavy tree growth as shown in Figure 4.

The results from the experiments with roughness are shown in Tables 10-21. The measured water-surface elevations shown in Tables 10-21 compared well with the computed water-surface elevations up to 991 cu m/sec (35,000 cfs), especially at sta 113+50 (the approximate location of Byram's Ford). Plots comparing the computed water-surface profile with the water-surface profile measured in the model for 283, 849, 991, and 2,265 cu m/sec (10,000, 30,000, 35,000 and 80,000 cfs) are shown in Plates 8-11. These measured values were then considered the baseline water-surface elevations for the weir design. Overbank water-surface elevations were measured for discharges of 991 and 1,557 cu m/sec (35,000 and 55,000 cfs) and are shown in Tables 22 and 23. The locations of these measurements are shown in Plate 2.

Swopes Park Flow

Velocities and water-surface elevations for 991 and 1,557 cu m/sec (35,000 and 55,000 cfs) were measured in the Swopes Park recreation area to calculate the amount of flow through the 63rd Street bridge and overland in Swopes Park. The locations of these measurements are shown in Plate 2. The discharge was calculated as shown:

$$Q_{\text{swopes}} = \sum_{i=1}^n (V_i A_i) \quad (1)$$

where

- Q_{swopes} = flow in Swopes Park, cfs
- n = number of cross-sectional areas, 9
- V_i = average of measured velocities in the i th area, fps
- A_i = i th cross-sectional area, ft²

The calculated flow in Swopes Park, Q_{swopes} , was then subtracted from the total discharge in the model, Q_{Total} , to determine the flow under the 63rd Street bridge, Q_{63} , as follows:

$$Q_{63} = Q_{\text{Total}} - Q_{\text{swopes}}$$

Of the 991 cu m/sec (35,000 cfs), 82 cu m/sec (2,900 cfs) was calculated to be flowing through Swopes Park and 909 cu m/sec (32,100 cfs) flowed under

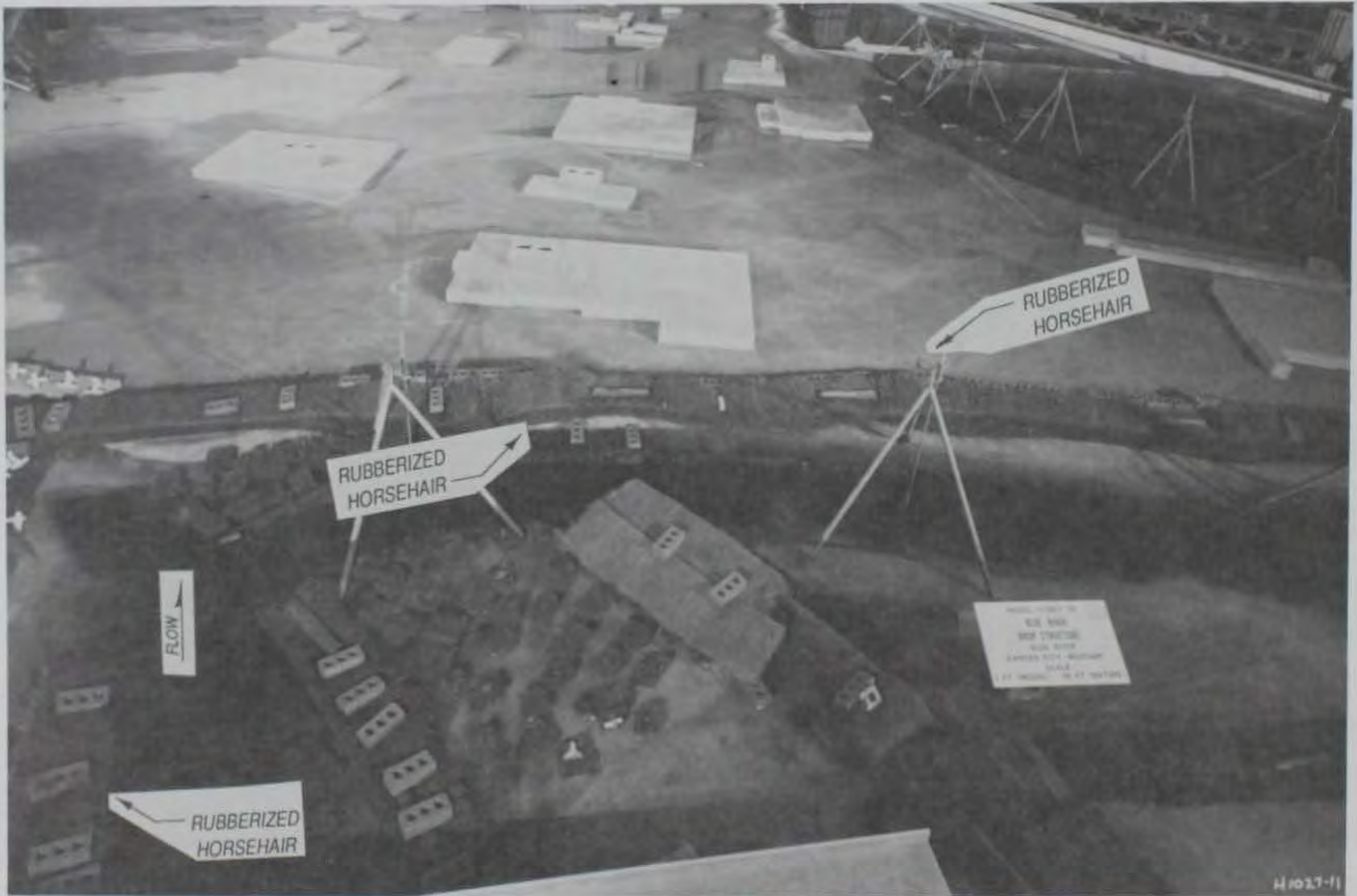

Figure 4. Placement of roughness material

the 63rd Street bridge. Of the 1,557 cu m/sec (55,000 cfs), 93 cu m/sec (3,300 cfs) was calculated to be flowing through Swopes Park and 1,464 cu m/sec (51,700 cfs) flowed under the 63rd Street bridge. The data are shown in Tables 24-27.

Weir Experiments

Experiments were conducted to design a weir that will provide a stage-discharge relationship upstream from sta 102+00 similar to the one determined from the calibration experiments with existing conditions. The proposed project includes a spoil bank to prevent left overbank flows for discharges up to 991 cu m/sec (35,000 cfs). This spoil bank was placed in the model for the weir design experiments. The spoil bank height was determined by setting the appropriate stage for a discharge of 991 cu m/sec (35,000 cfs) and preventing any flow over the left overbank with a vertical sheet metal wall. The water-surface elevation was marked along the wall and a spoil bank levee was then installed with the crown of the spoil bank at these elevations. The location of the spoil bank is shown in Plate 2.

Type 1 weir

The type 1 weir (Plate 1) was designed for the Kansas City District by a consulting firm to pass 1,926 cu m/sec (68,000 cfs). This design assumed all flow went through the weir and did not consider overtopping of the 991-cu m/sec (35,000-cfs) spoil bank. The water-surface elevations measured with the type 1 weir are shown in Tables 28-35. Stage-discharge curves for the type 1 weir at sta 102+00 (the first station upstream of the structure out of the drawdown zone) and sta 113+50 are shown in Plates 12 and 13, respectively, along with the stage-discharge curve for the baseline conditions. The type 1 weir performed well up to 283 cu m/sec (10,000 cfs), but was much too efficient for discharges greater than 283 cu m/sec (10,000 cfs). Plots comparing the computed water-surface profiles with the water-surface profiles measured in the model for 283, 991, and 2,265 cu m/sec (10,000, 35,000 and 80,000 cfs) are shown in Plates 14-16.

Types 2-13 weirs

The original design three-stage weir was modified in an attempt to match computed water-surface elevations provided by the Kansas City District. The types 2-13 weirs were modifications of the type 1 weir concept of keeping the entire weir overflow at sta 99+60. These designs are shown in Plates 17-20. The stepped type weir designs did not perform satisfactorily for the higher discharges, and matching the stage-discharge relationship with this type design was not possible.

Type 14 weir

The type 14 weir design shown in Plate 21 provided stages that were very close to the baseline conditions for the nonovertopping discharges up to 991 cu m/sec (35,000 cfs). The water-surface elevations measured with the type 14 weir are shown in Tables 36-44, and stage-discharge curves for the type 14 weir at sta 102+00 and 113+50 are shown in Plates 22 and 23, respectively. For discharges greater than 991 cu m/sec (35,000 cfs), the stages with the type 14 weir were lower than the baseline water-surface elevations. Plots comparing the computed water-surface profile with the water-surface profiles measured in the model for 283, 991, and 2,265 cu m/sec (10,000, 35,000 and 80,000 cfs) are shown in Plates 24-26. The type 14 weir was not desirable due to poor energy dissipation in the stilling basin, so additional designs were evaluated.

Type 15-21 weirs

The type 15-21 weirs consisted of modified drop inlet type designs. The details of these designs are shown in Plates 27-33. The type 21 weir design shown in Plate 33 provided stages that were very close to the baseline conditions for the nonovertopping discharges up to 991 cu m/sec (35,000 cfs). The water-surface elevations measured with the type 21 weir are shown in Tables 45-50, and stage-discharge curves for the type 21 weir at sta 102+00 and 113+50 are shown in Plates 34 and 35, respectively. Plots comparing the computed water-surface profile with the water-surface profiles measured in the model for 283 and 991 cu m/sec (10,000 and 35,000 cfs) are shown in Plates 36 and 37, respectively. Energy dissipation with the type 21 weir was much better than with the type 14 weir. Since the type 21 weir appeared feasible, changes to the approach channel and the original design stilling basin were made so that the riprap stability experiments could be conducted.

Type 22 and 23 weirs

The type 22 and 23 weirs consisted of modified drop inlet type designs with upstream debris deflectors and low-flow training walls in the stilling basin. The details of these designs are shown in Plates 38 and 39. The type 23 weir design shown in Figure 5 and Plate 39 provided stages that were very close to the baseline conditions for the nonovertopping discharges up to 991 cu m/sec (35,000 cfs). The water-surface elevations measured with the type 23 weir are shown in Tables 51-59, and stage-discharge curves for the type 23 weir at sta 102+00 and 113+50 are shown in Plates 40 and 41, respectively. Plots comparing the computed water-surface profile with the water-surface profiles measured in the model for 283, 991, and 2,265 cu m/sec (10,000, 35,000 and 80,000 cfs) are shown in Plates 42-44. Flow conditions with the Type 23 weir are shown in Photos 1-6 for 991, 1,557, and 2,265 cu m/sec (35,000, 55,000 and 80,000 cfs), respectively.



a. View from right bank

Figure 5. Type 23 weir design (Continued)

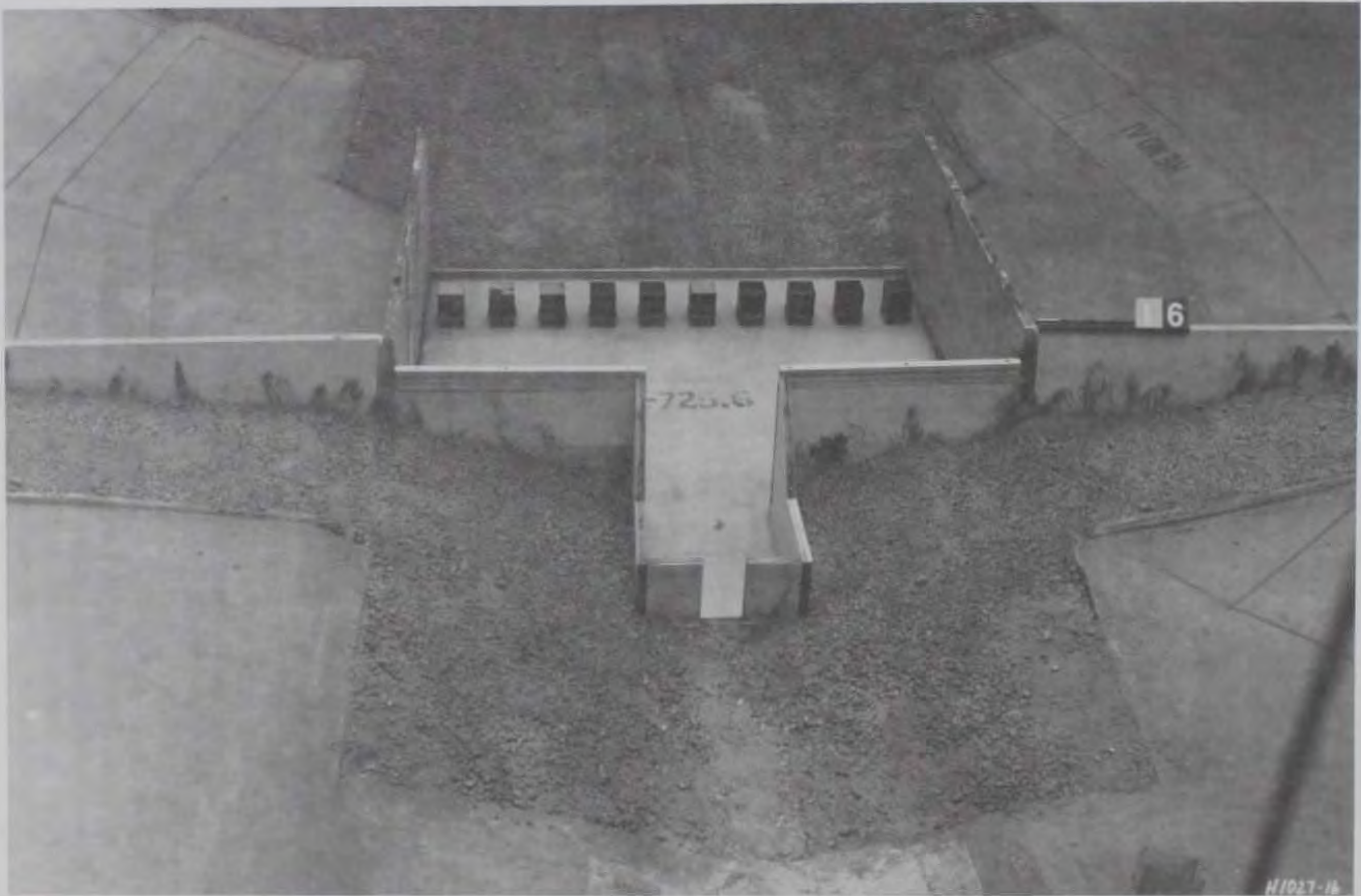

b. Looking downstream

Missouri River Division engineers requested comparative water-surface elevations and stage-discharge curves for weirs with crest elevations 0.6 and 1.2 m (2 and 4 ft) lower than the type 23 weir to determine if additional protection could be provided to the Byram's Ford Industrial Park without adversely impacting the Byram's Ford Crossing. These weirs, designated the type 24 and 25 weirs (Plates 45 and 46, respectively) were evaluated and the water-surface elevations measured with the type 25 weir are shown in Tables 60 and 61. Stage-discharge curves for the type 25 weir at sta 102+00 and 113+50 are shown in Plates 40 and 41, respectively. A comparison of the computed water-surface profile with the water-surface profile measured in the model for 2,265 cu m/sec (80,000 cfs) is shown in Plate 47. Flow conditions with the type 25 weir are shown in Photos 7-9 for 991, 1,557, and 2,265 cu m/sec (35,000, 55,000 and 80,000 cfs). A comparison of the computed water-surface profile with water-surface profiles measured in the model for 1,557 cu m/sec (55,000 cfs) for the types 23 and 25 weirs are shown in Plate 48.

Confined Flow Experiments

The Kansas City District requested that all flow for discharges greater than 991 cu m/sec (35,000 cfs) be routed over the weir to determine how much discharge was actually going over the weir when the spoil bank was overtopped (overtopping occurred only for discharges $>$ 991 cu m/sec (35,000 cfs)). To determine weir capacity for the type 23 and 25 weirs with flow confined to the river for discharges above 991 cu m/sec (35,000 cfs), the right tieback levee at el 782 and the spoil bank had to be raised. Discharges of 991, 1,132, 1,557, and 1,840 cu m/sec (35,000, 40,000, 55,000, and 65,000 cfs) were set, the tailwater elevation varied, and the water surface measured at sta 102+00 for each discharge to determine discharge capacity of each weir design. The data were plotted and are shown in Plates 49 and 50 and in Tables 62-69. This confined flow information was used to determine the amount of flow conveyed over the weir when the spoil bank became overtopped (above 991 cu m/sec (35,000 cfs)) with the unconfined flow conditions.

Weir discharges for the type 23 and 25 weirs were extrapolated from the confined flow curves for each discharge at a given tailwater and pool elevation. For example, given the tailwater elevation of 772.28 (tailwater rating curve in Plate 4), the water-surface elevation at sta 102+00 for a total unconfined flow of 2,265 cu m/sec (80,000 cfs) with the type 23 weir was 779.23 (Table 59). The confined flow curve for 991 cu m/sec (35,000 cfs) (Plate 49) indicates that for the combination of the water-surface elevation at sta 102+00 of 779.23 and tailwater elevation at 772.28 the type 23 weir passes 991 cu m/sec (35,000 cfs). Given the tailwater elevation of 766.71 (tailwater rating curve in Plate 4), the water-surface elevation at sta 102+00 for a total unconfined flow of 1,557 cu m/sec (55,000 cfs) with the type 25 weir was 777.36 (Table 60). For the tailwater el 766.71, the confined flow curve for

1,132 cu m/sec (40,000 cfs) (Plate 50) indicates the water-surface elevation at sta 102+00 was 776.7, and the confined flow curve for 1,557 cu m/sec (55,000 cfs) (Plate 50) indicates the water-surface elevation at sta 102+00 was 778.0. Mathematically interpolating between the two discharges, for the water-surface elevation of 777.36 (water-surface elevation at sta 102+00 for a total unconfined flow of 1,557 cu m/sec (55,000 cfs), tailwater el 766.71) 1,356 cu m/sec (47,900 cfs) passes over the weir. Weir discharges for the type 23 and 25 weirs are presented in Tables 70 and 71 for total unconfined discharges of 1,557, 1,840, and 2,265 cu m/sec (55,000, 65,000, and 80,000 cfs). It should be noted that as total flow increases, the discharge over the weir decreases because the tailwater is also increasing with increasing discharge.

Velocities at Byram's Ford

Velocities were measured at sta 112+00 and 113+50, the location of Byram's Ford, with existing conditions as well as with the type 23-25 weir designs for unconfined and confined flows. The bottom velocities for several discharges were compared to determine what impact, if any, channel improvements would have on the Byram's Ford crossing. Velocities for existing conditions are shown in Tables 72 and 73. Velocities for unconfined flow conditions with the type 23-25 weirs are tabulated in Tables 74-85. Center-line velocities for all conditions at the ford are tabulated in Tables 86-89 for the types 23 and 25 weirs.

The velocities along the center line at Byram's Ford with a discharge of 991 cu m/sec (35,000 cfs) increased from 1.1 to 1.6 m/sec (3.5 to 5.2 fps) with the type 23 design, from 1.1 to 1.6 m/sec (3.5 to 5.4 fps) with the type 24 design, and from 1.1 to 1.9 m/sec (3.5 to 6.1 fps) with the type 25 design. This indicated that decreasing the top elevation of the weir increased velocities at Byram's Ford. With the decrease in water-surface elevation due to the lower weir crest, more flow was confined to the channel, increasing the velocities along the channel center line. Conversely, with confined flow, the water-surface elevation increased and a portion of the total discharge began to flow across the river banks, decreasing the velocities along the channel center line. Velocities for confined flow conditions with the type 23-25 weirs are tabulated in Tables 90-98. It should be noted, however, at the lower, more frequent flood flows (28 to 283 cu m/sec (1,000 to 10,000 cfs)), the velocities along the center line ranged from 28 to 283 m/sec (3.3 to 7.2 fps) at sta 113+50. Because the stage elevations closely matched existing conditions for discharges up to and including 566 cu m/sec (20,000 cfs) with the type 25 weir and the types 23, 24, and 25 weir flow conditions were identical for discharges up to and including 566 cu m/sec (20,000 cfs), engineers from the Kansas City District and U.S. Army Engineer Waterways Experiment Station (WES) concluded that the velocities for these discharges did not differ between the existing conditions and the type 23, 24, and 25 weir designs. Therefore, based on frequent flow data, lowering the crest elevation of the

weir to el 770 (type 25 weir) will not increase velocities with existing conditions at Byram's Ford.

Debris Deflector Experiments

The original (type 1) design debris deflector (Plate 3) consisted of two 16-m- (54-ft-) long parallel walls sloping at 1V on 3H. This debris deflector increased water-surface elevations above the baseline throughout the river. The type 2 design debris deflector (Plate 51) consisting of two walls flared at 0.52 radian (30 degrees) to flow and sloping at 1V on 2H was evaluated. The type 2 debris deflector provided stages that were very close to the baseline conditions for the nonovertopping discharges up to 991 cu m/sec (35,000 cfs). Twigs simulating 6- to 9-m- (20- to 30-ft-) long logs were diverted through the structure. Visual observations of debris passage with the type 2 design debris deflector indicated satisfactory debris passage through the low-flow notch with the type 2 design. Photos 10-15 show debris passage with the type 2 design debris deflector.

Stilling Basin Experiments

The original (type 1) design stilling basin (Plate 3) consisted of an apron at el 725.6, parallel low-flow training walls, baffle blocks, and an end sill. Visual observations and velocity measurements over the end sill and 30 m (100 ft) downstream of the end sill with the type 23-25 weir designs indicated that a discharge of 991 cu m/sec (35,000 cfs) over the type 25 weir produced the worst flow conditions and highest bottom velocities. Therefore stilling basin experiments and riprap stability experiments were conducted with the type 25 weir. Velocities were measured downstream of the original (type 1) design stilling basin and type 25 weir and are shown in Plate 52. Velocities and visual observations indicated no improvement in flow conditions over the original basin. The stilling basin apron was elevated 1.2 m (4 ft) to el 729.6 from the weir to the end sill (type 3 stilling basin). This increased velocities downstream of the basin (Plate 53) and caused damage to riprap on the side slopes as shown in Plate 54 and discussed in the riprap experiments.

Riprap Requirements

The initial design of riprap protection extended up the left trail levee to el 782.0 and up the right slope as shown in Plate 55. The Kansas City District (CEMRK) proposed extending riprap protection 142 m (466 ft) downstream of the end sill. Riprap protection was installed in the model upstream of the type 25 weir and immediately downstream of the type 1 stilling basin end sill as shown in Plate 55. The upstream riprap protection gradation was based on the gradation for a 457-mm (18-in.) minimum layer thickness given

by the Kansas City District¹. The type 1 riprap design consisted of a 457-mm- (18-in.-) thick blanket (Class A) simulating protective stone with a $D_{50\text{mm}}$ of 292 mm (11.5 in.) placed 30.5 m (100 ft) upstream of the weir and 142 m (466 ft) downstream of the end sill as shown in Plate 55. A gradation curve for the riprap with the 457-mm- (18-in.-) blanket thickness is shown in Plate 56. Initially discharges of 991, 1,557, and 2,265 cu m/sec (35,000, 55,000 and 80,000 cfs) were run for 6 hours (prototype). The riprap remained stable upstream and downstream of the structure. The maximum discharge from the May 1990 flood, 991 cu m/sec (35,000 cfs), was then run for 36 hours (the duration of the peak flow as provided by the Kansas City District). The riprap immediately downstream of the end sill failed after 36 hours (prototype) of operation.

The riprap blanket thickness 30.5 m (100 ft) downstream of the end sill was increased to a 610-mm- (24-in.-) thick blanket (Class B) simulating protective stone with a $D_{50\text{mm}}$ of 381 mm (15 in.). This was designated the type 2 riprap design (Plate 57). The gradation curve for the riprap with a 610-mm (24-in.) blanket thickness is shown in Plate 58. The model was again operated with a discharge of 991 cu m/sec (35,000 cfs) for 36 hours (prototype). The type 2 riprap design remained stable for these conditions.

In an effort to reduce excavation during construction in the prototype, the elevation of the stilling basin apron from the weir to the end sill was raised 1.2 m (4 ft). This was designated the type 3 stilling basin, as described previously in the section, "Stilling Basin Experiments." The riprap blanket thickness 30.5 m (100 ft) downstream of the end sill remained 610 mm (24 in.) thick. The model was again operated with a discharge of 991 cu m/sec (35,000 cfs) for 36 hours (prototype). The riprap scoured downstream of the end sill and along the side slopes just downstream of the flared training walls as indicated in Plate 54. Bottom velocities measured downstream of the stilling basin are plotted in Plate 53. Measurements at several depths indicated that raising the basin apron floor 1.2 m (4 ft) increased velocities, especially closer to the water surface.

Left Trail Levee Experiments

During operation of the model, it was observed that at the highest discharge 2,265 cu m/sec (80,000 cfs), there was substantial freeboard on the left trail levee downstream of the structure. Water-surface elevations were measured for 122 m (400 ft) downstream of the end sill along the left trail levee for 991, 1,557, and 2,265 cu m/sec (35,000, 55,000 and 80,000 cfs) with the type 25 weir (Tables 99-101 and Plates 59-61). The Kansas City District engineers felt the left trail levee elevation could possibly be lowered below el 782, its original elevation.

¹ U. S. Army Engineer District, Kansas City. 1991. "Blue River Channel Modification Design Memorandum No. 4," Volume 1, Kansas City, Mo.

Overbank Flow Experiments

Discharges above 991 cu m/sec (35,000 cfs) flooded the industrial park in the left overbank. Water-surface elevations and velocities were measured with the type 23 and 25 design weirs (Tables 102-105 and 106-109). Generally, velocities increased and water-surface elevations decreased when the weir crest was lowered 1.2 m (4 ft) (type 25 weir).

Breached Spoil Bank Experiments

A 15 m- (50-ft-) wide section of the spoil bank was removed as shown in Plate 62 to simulate a breach in the spoil bank. Because the type 23 weir produced the highest stages of the types 23-25 weirs, the type 23 weir was evaluated with 991 cu m/sec (35,000 cfs) and the breached spoil bank. Water-surface elevations in the river channel, velocity measurements at Byram's Ford Crossing, and overbank water-surface elevations were measured to document what effect a breach in the spoil bank would have on the industrial park. The water-surface elevations in the channel decreased an average of 0.9 m (3 ft) and the velocities along the center line at Byram's Ford (sta 113+50) increased from 1.3 and 1.6 m/sec (4.4 and 5.2 fps (type 23 weir with no breach)) to 1.6 and 1.7 m/sec (5.3 and 5.6 fps) (type 23 weir with the 15-m (50-ft) breach in the spoil bank) along the center line at sta 112+00 and 113+50 at the 991-cu m/sec (35,000-cfs) discharge. With the lower water surface in the channel, flow was channelized and concentrated along the center line, causing the velocities along the channel centerline to increase. All pertinent data are included in Tables 110-112.

4 Conclusions

The model study initially addressed the hydraulic impact of the drop structure on the Byram's Ford Civil War Crossing. Additional experiments were conducted to determine if additional flood protection could be given the Byram's Ford Industrial Park by changing the drop structure design while minimizing impact on the ford. The three-stage (type 1, original) weir design shown in Plate 1 matched baseline water-surface elevations calculated by the Kansas City District for existing conditions for discharges up to about 283 cu m/sec (10,000 cfs). The three-sided (type 23) weir design shown in Figure 5 and Plate 39 provided stages that were very close to the baseline conditions for the nonovertopping discharges up to 991 cu m/sec (35,000 cfs). During the course of the study, some emphasis was placed on finding a tradeoff point where the weir design did not adversely impact on the Byram's Ford Crossing but would provide additional flood protection to the Byram's Ford Industrial Park area. The type 24 and 25 designs, consisting of lower crests, increased protection of the park with lower stage elevations at the higher, less frequent discharges of 991-2,265 cu m/sec (35,000-80,000 cfs).

As discharge increased above 991 cu m/sec (35,000 cfs), part of the flow passed under the 63rd Street bridge and part of the flow passed through Swopes Park. Velocities and water-surface elevations were used to calculate the amount of flow under the bridge and through the park. Experiments indicated that 91-94 percent of the flow passed under the 63rd Street bridge (910 and 1,464 cu m/sec (32,100 and 51,700 cfs) of 991 and 1,557 cu m/sec (35,000 and 55,000 cfs), respectively).

The bottom velocities at Byram's Ford for several discharges were compared to determine what impact, if any, channel improvements will have on the Byram's Ford crossing. Comparing the bottom velocities measured with simulated existing conditions to bottom velocities measured with the type 23, 24, and 25 weirs, the velocity along the center line of the channel increased from 1.01 and 1.1 m/sec (3.5 and 3.7 fps) (existing conditions at sta 112+00 and 113+50) to 1.3 and 1.6 m/sec (4.4 and 5.2 fps) (at sta 112+00 and 113+50), 1.4 and 1.6 m/sec (4.7 and 5.4 fps) (sta 112+00 and 113+50), and 1.6 and 1.9 m/sec (5.1 and 6.1 fps) (sta 112+00 and 113+50) for the type 23, 24, and 25 weirs, respectively, and a discharge of 991 cu m/sec (35,000 cfs). Velocities along the center line at Byram's Ford (sta 113+50) ranged from 0.99 to 2.2 m/sec (3.3 to 7.2 fps) for the more frequent flood

flows of 28 to 283 cu m/sec (1,000 to 10,000 cfs). The stages remained unchanged with the type 24 and 25 weir designs; therefore, engineers at WES and the Kansas City District concluded that lowering the crest elevation by 1.2 m (4 ft) did not change velocities at the ford from the velocities that occurred with existing conditions. Therefore WES recommends the type 25 weir (Plate 46) with weir crest at el 770 for prototype construction.

The original parallel sloped deflectors increased water-surface elevations throughout the river and caused debris to jam in the low-flow slot. Experiments indicated that a 0.52-rad (30-deg) flare of the debris deflector was necessary to improve the draw of debris through the low-flow slot. The type 2 design debris deflector (Plate 51) consisting of two walls flared at 0.52 rad (30 deg) to flow and sloping at 1V on 2H is recommended for prototype construction.

The original (type 1) design stilling basin (Plate 3) consisted of an apron at el 725.6, parallel low-flow training walls, baffle blocks, and an end sill. Visual observations and velocity measurements over the end sill and 30.5 m (100 ft) downstream of the end sill with the types 23-25 weir designs indicated that a discharge of 991 cu m/sec (35,000 cfs) over the type 25 weir produced the highest bottom velocities. Therefore stilling basin experiments and riprap stability experiments were conducted with the type 25 weir. Flaring the low-flow training walls increased velocities at the corners of the flared walls. Elevating the stilling basin apron 1.2 m (4 ft) also increased velocities and caused damage to the riprap blanket downstream of the structure. It is recommended that the stilling basin with low-flow training walls be built as originally designed with the apron at el 725.6.

The upstream riprap protection gradation was based on the gradation for an 457-mm (18-in.) minimum layer thickness given by the U.S. Army Engineer District, Kansas City.¹ The downstream riprap protection gradation was based on Hydraulic Design Criteria Sheet 712-1.² A 457-mm- (18-in.-) thick blanket (Plate 56) of protective stone with a D_{50min} of 292 mm (11.5 in.) (Class A) was placed for 30.5 m (100 ft) upstream of the weir (Plate 57). The riprap remained stable after 991 cu m/sec (35,000 cfs) was discharged for 36 hours (prototype). Riprap protection 457 mm (18 in.) thick is recommended for 30.5 m (100 ft) upstream of the weir.

The riprap blanket thickness 30.5 (100 ft) downstream of the end sill was increased to a 610-mm- (24-in.-) thick blanket (Plate 57) simulating protective stone with a D_{50min} of 381 mm (15 in.) (Class B) followed by 112 m (366 ft) of the 457-mm- (18-in.-) thick blanket. The riprap remained stable after 991 cu m/sec (35,000 cfs) was discharged for 36 hours (prototype). Riprap

¹ U.S. Army Engineer District, Kansas City. 1991. "Blue River Channel Modification Design Memorandum No. 4," Volume 1, Kansas City, MO.

² "Hydraulic Design Criteria," published periodically since 1952 for Headquarters, U.S. Army Corps of Engineers by the U.S. Army Engineer Waterways Experiment Station, Vicksburg, MS.

protection 610 mm (24 in.) thick is recommended for 30.5 m (100 ft) downstream of the end sill followed by 457-mm- (18-in.-) thick riprap for 112 m (366 ft).

The right tieback levee at el 782 and the spoil bank needed to be raised when flows above 991 cu m/sec (35,000 cfs) were confined to the river to develop rating curves for the types 23-25 weirs. Rating curves were developed for the types 23-25 weirs. During operation of the model, it was observed that at the highest discharge, 2,265 cu m/sec (80,000 cfs), the left trail levee downstream of the structure was exposed above the water surface, indicating the left trail levee elevation could be lowered. The maximum measured water-surface elevation was 777.57 with 2,265 cu m/sec (80,000 cfs). The left trail levee minimum elevation should be set at 778 plus any freeboard needed for structural stability and/or factor of safety against overtopping. The Kansas City District should decide the final left trail levee elevation.

Discharges above 991 cu m/sec (35,000 cfs) flooded the industrial park in the left overbank. Water-surface elevations and velocities were measured with the types 23 and 25 design weirs (Tables 102-105 and 106-109, respectively). Using weir rating information taken during confined flow experiments, weir and overbank discharge were determined for several flow conditions.

A 15-m- (50-ft-) wide section of the spoil bank was removed as shown in Plate 62 to simulate a breach in the spoil bank. Because the type 23 weir produced the highest stages of the types 23-25 weirs, the type 23 weir was evaluated with 991 cu m/sec (35,000 cfs). Water-surface elevations in the river channel, velocity measurements at Byram's Ford Crossing, and overbank water-surface elevations were measured to document what effect a breach in the spoil bank would have on the industrial park. The water-surface elevations throughout the river were lowered 2-4 ft with the breach. The velocities at the ford increased from 1.3 and 1.6 m/sec (4.4 and 5.2 fps) (type 23 weir with no breach) to 1.6 and 1.7 m/sec (5.3 and 5.6 fps) (type 23 weir with 15-m (50-ft) breach) along the center line at sta 112+00 and 113+50 at the 991-cu-m/sec (35,000-cfs)-discharge.

Summarizing, the type 25 weir with crest at el 770 (Plate 46) is recommended for prototype construction to provide maximum flood protection to the Byram's Ford Industrial Park while minimizing impact on velocities at Byram's Ford. The originally designed stilling basin with low-flow training walls and apron at el 725.6 performed satisfactorily for the range of flow conditions evaluated and is recommended for prototype construction. Debris deflectors flared at 0.52 rad (30 deg) to flow with walls 1V on 2H are recommended to provide satisfactory passage of trash through the structure. Riprap 457 mm (18 in.) thick with a D_{50mm} of 292 mm (11.5 in.) (Class A) placed for 30.5 m (100 ft) upstream of the weir is recommended for upstream protection of the weir. Riprap 610 mm (24 in.) thick with a D_{50mm} of 381 mm (15 in.) (Class B) followed by 112 m (366 ft) of the 457-mm- (18-in.-) thick blanket is recommended for protection of the downstream exit channel. The left trail

levee minimum elevation should be set at 778 plus any freeboard needed for structural stability and/or factor of safety against overtopping. The Kansas City District should decide the final left trail levee elevation.

Table 1
Water-Surface Elevations, Original Design, Discharge
28 cu m/sec (1,000 cfs)

Sta	Computed Water-Surface Elevation	Measured Water-Surface Elevation	Prototype Difference ft ¹
135+50	745.28	744.17	1.11
131+90	745.11	744.56	0.55
128+60	744.95	744.67	0.28
123+95	744.80	744.09	0.71
120+15	744.49	743.88	0.61
116+50	744.05	743.70	0.35
113+50	743.73	743.77	-0.04
112+00	743.53	743.59	-0.06
110+00	743.39	743.59	-0.20
108+00	743.26	743.45	-0.19
106+00	743.12	743.05	0.07
104+00	742.96	743.13	-0.17
102+00	742.82	742.80	0.02
100+00	742.67	743.20	-0.53

¹ To convert difference to meters, multiply by 0.3048.

Table 2
Water-Surface Elevations, Original Design, Discharge
57 cu m/sec (2,000 cfs)

Sta	Computed Water-Surface Elevation	Measured Water-Surface Elevation	Prototype Difference ft ¹
135+50	749.64	748.41	1.23
131+90	749.47	748.84	0.63
128+60	749.34	749.13	0.21
123+95	749.19	748.67	0.52
120+15	748.90	748.49	0.41
116+50	748.60	748.31	0.29
113+50	748.37	748.52	-0.15
112+00	748.26	748.27	-0.01
110+00	748.20	748.34	-0.14
108+00	748.11	748.20	-0.09
106+00	748.02	747.98	0.04
104+00	747.93	748.13	-0.20
102+00	747.84	747.91	-0.07
100+00	747.73	748.34	-0.61

¹ To convert difference to meters, multiply by 0.3048.

Table 3
Water-Surface Elevations, Original Design, Discharge
142 cu m/sec (5,000 cfs)

Sta	Computed Water-Surface Elevation	Measured Water-Surface Elevation	Prototype Difference ft ¹
135+50	756.09	755.76	0.33
131+90	755.94	755.97	-0.03
128+60	755.83	756.08	-0.25
123+95	755.66	755.69	-0.03
120+15	755.36	755.40	-0.04
116+50	755.10	755.36	-0.26
113+50	754.83	755.07	-0.24
112+00	754.75	755.04	-0.29
110+00	754.70	755.08	-0.38
108+00	754.62	754.89	-0.27
106+00	754.51	754.53	-0.02
104+00	754.43	754.61	-0.18
102+00	754.32	754.39	-0.07
100+00	754.21	754.82	-0.61

¹ To convert difference to meters, multiply by 0.3048.

Table 4
Water-Surface Elevations, Original Design, Discharge
283 cu m/sec (10,000 cfs)

Sta	Computed Water-Surface Elevation	Measured Water-Surface Elevation	Prototype Difference ft ¹
135+50	762.59	763.10	-0.51
131+90	762.46	762.85	-0.39
128+60	762.35	762.63	-0.28
123+95	762.16	762.38	-0.22
120+15	761.91	762.27	-0.36
116+50	761.66	761.95	-0.29
113+50	761.45	761.45	0.00
112+00	761.35	761.19	0.16
110+00	761.31	761.38	-0.07
108+00	761.25	761.27	-0.02
106+00	761.14	761.23	-0.09
104+00	761.07	761.38	-0.31
102+00	760.95	760.94	0.01
100+00	760.86	761.05	-0.19

¹ To convert difference to meters, multiply by 0.3048.

Table 5
Water-Surface Elevations, Original Design, Discharge
566 cu m/sec (20,000 cfs)

Sta	Computed Water-Surface Elevation	Measured Water-Surface Elevation	Prototype Difference ft ¹
135+50	770.61	769.91	0.70
131+90	770.43	769.90	0.53
128+60	770.32	770.05	0.27
123+95	770.07	769.58	0.49
120+15	769.80	769.65	0.15
116+50	769.50	769.33	0.17
113+50	769.25	770.63	-1.38
112+00	769.11	768.86	0.25
110+00	769.06	768.94	0.12
108+00	769.00	768.75	0.25
106+00	768.86	768.72	0.14
104+00	768.78	768.87	-0.09
102+00	768.62	768.61	0.01
100+00	768.52	768.86	-0.34

¹ To convert difference to meters, multiply by 0.3048.

Table 6
Water-Surface Elevations, Original Design, Discharge
849 cu m/sec (30,000 cfs)

Sta	Computed Water-Surface Elevation	Measured Water-Surface Elevation	Prototype Difference ft ¹
135+50	776.52	774.37	2.15
131+90	776.32	774.76	1.56
128+60	776.21	775.20	1.01
123+95	775.89	774.77	1.12
120+15	775.61	774.77	0.84
116+50	775.23	774.48	0.75
113+50	774.97	774.69	0.28
112+00	774.77	774.41	0.36
110+00	774.71	774.52	0.19
108+00	774.67	774.33	0.34
106+00	774.52	774.30	0.22
104+00	774.43	774.41	0.02
102+00	774.21	774.30	-0.09
100+00	774.12	774.52	-0.40

¹ To convert difference to meters, multiply by 0.3048.

Table 7
Water-Surface Elevations, Original Design, Discharge
1,132 cu m/sec (40,000 cfs)

Sta	Computed Water-Surface Elevation	Measured Water-Surface Elevation	Prototype Difference ft ¹
135+50	780.27	777.00	3.27
131+90	780.02	777.50	2.52
128+60	779.89	777.93	1.96
123+95	779.47	777.61	1.86
120+15	779.13	777.54	1.59
116+50	778.64	777.29	1.35
113+50	778.31	777.83	0.48
112+00	778.02	777.36	0.66
110+00	777.95	777.40	0.55
108+00	777.91	777.25	0.66
106+00	777.73	777.21	0.52
104+00	777.62	777.33	0.29
102+00	777.32	777.25	0.07
100+00	777.21	777.47	-0.26

¹ To convert difference to meters, multiply by 0.3048.

Table 8
Water-Surface Elevations, Original Design, Discharge
1,697 cu m/sec (60,000 cfs)

Sta	Computed Water-Surface Elevation	Measured Water-Surface Elevation	Prototype Difference ft ¹
135+50	782.85	779.77	3.08
131+90	782.64	780.24	2.40
128+60	782.64	780.63	2.01
123+95	782.16	780.35	1.81
120+15	781.69	780.31	1.38
116+50	781.33	780.06	1.27
113+50	781.14	780.31	0.83
112+00	780.71	780.20	0.51
110+00	780.82	780.24	0.58
108+00	780.88	779.99	0.89
106+00	780.68	780.02	0.66
104+00	780.54	780.14	0.40
102+00	780.16	780.16	0.00
100+00	780.10	780.28	-0.18

¹ To convert difference to meters, multiply by 0.3048.

Table 9
Water-Surface Elevations, Original Design, Discharge
2,265 cu m/sec (80,000 cfs)

Sta	Computed Water-Surface Elevation	Measured Water-Surface Elevation	Prototype Difference ft ¹
135+50	784.66	781.57	3.09
131+90	784.41	782.04	2.37
128+60	784.10	782.47	1.63
123+95	783.83	782.11	1.72
120+15	783.87	782.11	1.76
116+50	783.34	781.93	1.41
113+50	783.04	782.11	0.93
112+00	782.56	781.97	0.59
110+00	782.83	782.08	0.75
108+00	782.62	781.71	0.91
106+00	782.41	781.86	0.55
104+00	782.17	782.01	0.16
102+00	781.88	781.89	-0.01
100+00	781.87	782.18	-0.31

¹ To convert difference to meters, multiply by 0.3048.

Table 10
Water-Surface Elevations, with Roughness, Discharge
28 cu m/sec (1,000 cfs)

Sta	Computed Water-Surface Elevation	Measured Water-Surface Elevation	Prototype Difference ft ¹
135+50	745.28	745.28	0.00
131+90	745.11	745.21	-0.10
128+60	744.95	745.46	-0.51
123+95	744.80	744.96	-0.16
120+15	744.49	744.45	0.04
116+50	744.05	744.06	-0.01
113+50	743.73	743.84	-0.11
112+00	743.53	743.66	-0.13
110+00	743.39	743.70	-0.31
108+00	743.26	743.27	-0.01
106+00	743.12	743.05	0.07
104+00	742.96	743.24	-0.28
102+00	742.82	742.94	-0.12
100+00	742.67	743.45	-0.78

¹ To convert difference to meters, multiply by 0.3048.

Table 11
Water-Surface Elevations, with Roughness, Discharge
57 cu m/sec (2,000 cfs)

Sta	Computed Water-Surface Elevation	Measured Water-Surface Elevation	Prototype Difference ft ¹
135+50	749.64	749.53	0.11
131+90	749.47	749.28	0.19
128+60	749.34	749.53	-0.19
123+95	749.19	749.13	0.06
120+15	748.90	748.85	0.05
116+50	748.60	748.52	0.08
113+50	748.37	748.34	0.03
112+00	748.26	748.23	0.03
110+00	748.20	748.38	-0.18
108+00	748.11	748.16	-0.05
106+00	748.02	747.91	0.11
104+00	747.93	748.06	-0.13
102+00	747.84	747.87	-0.03
100+00	747.73	748.34	-0.61

¹ To convert difference to meters, multiply by 0.3048.

Table 12
Water-Surface Elevations, with Roughness, Discharge
142 cu m/sec (5,000 cfs)

Sta	Computed Water-Surface Elevation	Measured Water-Surface Elevation	Prototype Difference ft ¹
135+50	756.09	756.30	-0.21
131+90	755.94	755.83	0.11
128+60	755.83	756.12	-0.29
123+95	755.66	755.83	-0.17
120+15	755.36	755.69	-0.33
116+50	755.10	755.29	-0.19
113+50	754.83	755.07	-0.24
112+00	754.75	754.82	-0.07
110+00	754.70	755.00	-0.30
108+00	754.62	754.79	-0.17
106+00	754.51	754.46	0.05
104+00	754.43	754.40	0.03
102+00	754.32	754.24	0.08
100+00	754.21	754.57	-0.36

¹ To convert difference to meters, multiply by 0.3048.

Table 13
Water-Surface Elevations, with Roughness, Discharge
283 cu m/sec (10,000 cfs)

Sta	Computed Water-Surface Elevation	Measured Water-Surface Elevation	Prototype Difference ft ¹
135+50	762.59	764.94	-2.35
131+90	762.46	763.82	-1.36
128+60	762.35	764.22	-1.87
123+95	762.16	762.92	-0.76
120+15	761.91	762.56	-0.65
116+50	761.66	762.42	-0.76
113+50	761.45	762.53	-1.08
112+00	761.35	761.88	-0.53
110+00	761.31	762.10	-0.79
108+00	761.25	762.06	-0.81
106+00	761.14	761.77	-0.63
104+00	761.07	761.67	-0.60
102+00	760.95	760.98	-0.03
100+00	760.86	761.45	-0.59

¹ To convert difference to meters, multiply by 0.3048.

Table 14
Water-Surface Elevations, with Roughness, Weir in Place and
Roughness Redistributed, Discharge 566 cu m/sec (20,000 cfs)

Sta	Computed Water-Surface Elevation	Measured Water-Surface Elevation	Prototype Difference ft ¹
144+00		771.71	
135+50	770.61	770.73	-0.12
131+90	770.43	770.30	0.13
128+60	770.32	770.34	-0.02
123+95	770.07	770.23	-0.16
120+15	769.80	769.15	0.65
116+50	769.50	769.84	-0.34
113+50	769.25	769.33	-0.08
112+00	769.11	769.04	0.07
110+00	769.06	769.19	-0.13
108+00	769.00	768.97	0.03
106+00	768.86	768.65	0.21
104+00	768.78	768.87	-0.09
102+00	768.62	768.61	0.01

¹ To convert difference to meters, multiply by 0.3048.

Table 15
Water-Surface Elevations, with Roughness, Discharge
849 cu m/sec (30,000 cfs)

Sta	Computed Water-Surface Elevation	Measured Water-Surface Elevation	Prototype Difference ft ¹
135+50	776.52	775.20	1.32
131+90	776.32	775.27	1.05
128+60	776.21	775.74	0.47
123+95	775.89	775.16	0.73
120+15	775.61	774.95	0.66
116+50	775.23	774.77	0.46
113+50	774.97	774.73	0.24
112+00	774.77	774.51	0.26
110+00	774.71	774.59	0.12
108+00	774.67	774.41	0.26
106+00	774.52	774.37	0.15
104+00	774.43	774.48	-0.05
102+00	774.21	774.22	-0.01

¹ To convert difference to meters, multiply by 0.3048.

Table 16
Water-Surface Elevations, with Roughness, Discharge
991 cu m/sec (35,000 cfs)

Sta	Interpolated Water-Surface Elevation	Measured Water-Surface Elevation	Prototype Difference ft ¹
135+50	778.39	777.00	1.39
131+90	778.17	777.25	0.92
128+60	778.05	777.61	0.44
123+95	777.68	777.07	0.61
120+15	777.37	776.82	0.55
116+50	776.93	776.60	0.33
113+50	776.64	776.60	0.04
112+00	776.39	776.39	0.00
110+00	776.33	776.46	-0.13
108+00	776.29	776.31	-0.02
106+00	776.12	776.21	-0.09
104+00	776.02	776.28	-0.26
102+00	775.76	775.95	-0.19

¹ To convert difference to meters, multiply by 0.3048.

Table 17
Water-Surface Elevations, with Roughness, Discharge
1,132 cu m/sec (40,000 cfs)

Sta	Computed Water-Surface Elevation	Measured Water-Surface Elevation	Prototype Difference ft ¹
135+50	780.27	777.86	2.41
131+90	780.02	778.15	1.87
128+60	779.89	778.55	1.34
123+95	779.47	778.08	1.39
120+15	779.13	777.90	1.23
116+50	778.64	777.68	0.96
113+50	778.31	777.36	0.95
112+00	778.02	777.97	0.05
110+00	777.95	777.61	0.34
108+00	777.91	777.50	0.41
106+00	777.73	777.39	0.34
104+00	777.62	777.54	0.08
102+00	777.32	777.32	0.00

¹ To convert difference to meters, multiply by 0.3048.

Table 18
Water-Surface Elevations, with Roughness, Weir and Levee in
Place, Roughness Redistributed, Discharge 1,557 cu m/sec
(55,000 cfs)

Sta	Computed Water-Surface Elevation	Measured Water-Surface Elevation	Prototype Difference ft ¹
144+00		780.96	
135+50	782.80	780.24	2.56
131+90	782.56	780.42	2.14
128+60	782.50	780.49	2.01
123+95	782.03	780.42	1.61
120+15	781.60	780.27	1.33
116+50	781.12	780.10	1.02
113+50	780.84	779.95	0.89
112+00	780.44	779.70	0.74
110+00	780.47	779.84	0.63
108+00	780.49	779.66	0.83
106+00	780.29	779.66	0.63
104+00	780.16	779.88	0.28
102+00	779.78	779.77	0.01

¹ To convert difference to meters, multiply by 0.3048.

Table 19
Water-Surface Elevations, with Roughness, Discharge
1,697 cu m/sec (60,000 cfs)

Sta	Computed Water-Surface Elevation	Measured Water-Surface Elevation	Prototype Difference ft ¹
135+50	782.85	780.63	2.22
131+90	782.64	780.81	1.83
128+60	782.64	781.21	1.43
123+95	782.16	780.89	1.27
120+15	781.69	780.63	1.06
116+50	781.33	780.42	0.91
113+50	781.14	780.56	0.58
112+00	780.71	780.38	0.33
110+00	780.82	780.42	0.40
108+00	780.88	780.06	0.82
106+00	780.68	780.20	0.48
104+00	780.54	780.39	0.15
102+00	780.16	780.20	-0.04

¹ To convert difference to meters, multiply by 0.3048.

Table 20
Water-Surface Elevations, with Roughness, Discharge
1,840 cu m/sec (65,000 cfs)

Sta	Computed Water-Surface Elevation	Measured Water-Surface Elevation	Prototype Difference ft ¹
135+50	783.30	780.92	2.38
131+90	783.08	781.32	1.76
128+60	783.00	781.71	1.29
123+95	782.58	781.35	1.23
120+15	782.23	781.10	1.13
116+50	781.83	780.89	0.94
113+50	781.61	780.99	0.62
112+00	781.17	780.78	0.39
110+00	781.32	780.89	0.43
108+00	781.31	780.60	0.71
106+00	781.11	780.63	0.48
104+00	780.95	780.75	0.20
102+00	780.59	780.60	-0.01

¹ To convert difference to meters, multiply by 0.3048.

Table 21
Water-Surface Elevations, with Roughness, Discharge
2,265 cu m/sec (80,000 cfs)

Sta	Computed Water-Surface Elevation	Measured Water-Surface Elevation	Prototype Difference ft ¹
135+50	784.66	782.11	2.55
131+90	784.41	782.50	1.91
128+60	784.10	782.97	1.13
123+95	783.83	782.61	1.22
120+15	783.87	782.36	1.51
116+50	783.34	782.18	1.16
113+50	783.04	782.25	0.79
112+00	782.56	782.07	0.49
110+00	782.83	782.15	0.68
108+00	782.62	781.93	0.69
106+00	782.41	781.89	0.52
104+00	782.17	782.08	0.09
102+00	781.88	781.89	-0.01

¹ To convert difference to meters, multiply by 0.3048.

Table 22
Overbank Water-Surface Elevations, with Roughness, Discharge
991 cu m/sec (35,000 cfs)

Range	Water-Surface Elevation	Range	Water-Surface Elevation
Range 1		Range 2 (Continued)	
R1-1	775.9	R2-18	775.7
R1-2	776.0	R2-19	775.8
R1-3	776.1	Range 3	
R1-4	775.9	R3-1	776.0
R1-5	775.7	R3-2	776.1
R1-6	775.5	R3-3	776.0
R1-7	776.3	R3-4	775.9
R1-8	775.8	R3-5	775.8
R1-9	775.8	R3-6	776.5
R1-10	775.5	R3-7	776.1
R1-11	775.5	R3-8	776.1
R1-12	775.7	R3-9	776.0
Range 2		R3-10	775.8
R2-1	776.0	R3-11	775.9
R2-2	776.0	R3-12	775.9
R2-3	775.9	R3-13	775.5
R2-4	776.0	R3-14	775.7
R2-5	775.9	R3-15	775.9
R2-6	776.0	R3-16	775.7
R2-7	776.0	R3-17	775.9
R2-8	775.8	R3-18	775.7
R2-9	775.7	Range 4	
R2-10	776.0	R4-1	
R2-11	775.8	R4-2	775.9
R2-12	775.7	R4-3	776.0
R2-13	775.8	R4-4	776.0
R2-14	775.8	R4-5	776.0
R2-15	775.8	R4-6	776.0
R2-16	775.6	R4-7	775.9
R2-17	775.7	R4-8	775.9

(Continued)

Table 22 (Concluded)

Range	Water-Surface Elevation	Range	Water-Surface Elevation
Range 4 (Continued)		Range 4 (Continued)	
R4-9	775.8	R4-11	775.6
R4-10	775.8	R4-12	775.7

Table 23
Overbank Water-Surface Elevations, with Roughness, Discharge
1,557 cu m/sec (55,000 cfs)

Range	Water-Surface Elevation	Range	Water-Surface Elevation
Range 1		Range 3	
R1-1	779.7	R3-1	780.0
R1-2	779.8	R3-2	780.0
R1-3	780.0	R3-3	780.1
R1-4	779.8	R3-4	780.3
R1-5	779.5	R3-5	780.3
R1-6	779.6	R3-6	780.2
R1-7	779.6	R3-7	779.8
R1-8	779.6	R3-8	779.9
R1-9	779.7	R3-9	779.6
R1-10	779.3	R3-10	779.6
R1-11	779.5	R3-11	779.7
R1-12	779.4	R3-12	779.7
Range 2		R3-13	779.5
R2-9	779.5	R3-14	779.5
R2-10	779.8	R3-15	779.7
R2-11	779.6	R3-16	779.6
R2-12	779.5	R3-17	779.7
R2-13	779.6	R3-18	779.6
R2-14	779.5	R3-19	779.7
R2-15	779.6	Range 4	
R2-16	779.5	R4-1	
R2-17	779.5	R4-2	779.7
R2-18	779.5	R4-3	779.7

(Continued)

Table 23 (Concluded)

Range	Water-Surface Elevation	Range	Water-Surface Elevation
Range 4 (Continued)		Range 4 (Continued)	
R4-4	779.6	R4-11	779.6
R4-5	779.9	R4-12	779.6
R4-6	779.7	R4-13	779.4
R4-7	779.7	R4-14	779.3
R4-8	779.6	R4-15	779.4
R4-9	779.7	R4-16	779.4
R4-10	779.5	R4-17	779.4

Table 24
Velocities in Swopes Park, Type 14 Weir, Discharge
991 cu m/sec (35,000 cfs)

Sta	Depth ¹	Velocity fps ²
0+00	M	1.15
1+80	B	2.13
3+60	M	6.35
5+40	M	3.12
7+20	M	4.91
9+00	M	5.13
10+80	B	2.03
	M	2.08
12+60	B	1.36
	M	1.34
	T	1.35
14+40	B	0.97
	M	1.05
	T	1.06
16+20	B	1.39
	M	0.99
	T	1.00

¹ B = bottom, M = middepth, T = top.

² To convert velocities to meters per second, multiply by 0.3048.

Table 25
Velocities in Swopes Park, Type 14 Weir, Discharge
1,557 cu m/sec (55,000 cfs)

Sta	Depth ¹	Velocity fps ²
0+00	B	1.86
	M	1.60
	T	1.96
1+80	B	2.13
	M	2.24
	T	2.28
3+60	B	1.27
	M	1.32
	T	1.38
5+40	B	1.97
	M	2.13
	T	2.07
7+20	B	2.47
	M	2.53
	T	2.54
9+00	B	2.69
	M	2.73
	T	2.78
10+80	B	2.28
	M	2.40
	T	2.40
12+60	B	1.55
	M	1.59
	T	1.56
14+40	B	1.5
	M	1.5
	T	1.5
16+20	B	1.5
	M	1.5
	T	1.5

¹ B = bottom, M = middepth, T = top.

² To convert velocities to meters per second, multiply by 0.3048.

Table 26
Water-Surface Elevations in Swopes Park, Type 14 Weir,
Discharge 991 cu m/sec (35,000 cfs)

Sta	Invert El	Water-Surface El
0+00	771.35	776.89
1+80	773.76	776.60
3+60	772.68	776.60
5+40	772.50	776.64
7+20	773.76	780.35
9+00	773.04	775.63
10+80	768.94	772.61
12+60	754.75	772.93
14+40	755.83	772.97
16+20	769.01	772.93

Table 27
Water-Surface Elevations in Swopes Park, Type 14 Weir,
Discharge 1,557 cu m/sec (55,000 cfs)

Sta	Invert El	Water-Surface El
0+00	771.35	776.82
1+80	773.76	778.12
3+60	772.68	779.41
5+40	772.50	779.95
7+20	773.76	780.20
9+00	773.04	779.41
10+80	768.94	779.34
12+60	754.75	779.66
14+40	755.83	779.99
16+20	769.01	779.56

Table 28
Water-Surface Elevations, with Roughness, Type 1 Weir,
Discharge 28 cu m/sec (1,000 cfs)

Sta	Baseline Water-Surface EI	Type 1 Weir Water-Surface EI	Prototype Difference ft ¹
135+50	745.28	745.53	-0.25
131+90	745.21	745.39	-0.18
128+60	745.46	745.35	0.11
123+95	744.96	745.07	-0.11
120+15	744.45	744.60	-0.15
116+50	744.06	744.17	-0.11
113+50	743.84	743.73	0.11
112+00	743.66	743.59	0.07
110+00	743.70	743.63	0.07
108+00	743.27	743.48	-0.21
106+00	743.05	743.05	0.00
104+00	743.24	743.24	0.00
102+00	742.94	743.16	-0.22

¹ To convert prototype differences to millimeters, multiply by 304.8.

Table 29
Water-Surface Elevations, with Roughness, Type 1 Weir,
Discharge 57 cu m/sec (2,000 cfs)

Sta	Baseline Water-Surface El	Type 1 Weir Water-Surface El	Prototype Difference ft ¹
135+50	749.53	749.78	-0.25
131+90	749.28	749.71	-0.43
128+60	749.53	749.78	-0.25
123+95	749.13	749.53	-0.40
120+15	748.85	749.42	-0.57
116+50	748.52	749.10	-0.58
113+50	748.34	749.03	-0.69
112+00	748.23	748.85	-0.62
110+00	748.38	748.96	-0.58
108+00	748.16	748.85	-0.69
106+00	747.91	748.63	-0.72
104+00	748.06	748.78	-0.72
102+00	747.87	748.81	-0.94

¹ To convert prototype differences to millimeters, multiply by 304.8.

Table 30
Water-Surface Elevations, with Roughness Redistributed, Type 1
Weir, Discharge 142 cu m/sec (5,000 cfs)

Sta	Baseline Water-Surface EI	Type 1 Weir Water-Surface EI	Prototype Difference ft ¹
144+00		757.67	
135+50	756.30	756.33	-0.03
131+90	755.83	756.08	-0.25
128+60	756.12	756.01	0.11
123+95	755.83	755.90	-0.07
120+15	755.69	755.72	-0.03
116+50	755.29	755.40	-0.11
113+50	755.07	755.07	0.00
112+00	754.82	754.93	-0.11
110+00	755.00	754.90	0.10
108+00	754.79	754.89	-0.10
106+00	754.46	754.53	-0.07
104+00	754.40	754.72	-0.32
102+00	754.24	754.32	-0.08

¹ To convert prototype differences to millimeters, multiply by 304.8.

Table 31
Water-Surface Elevations, with Roughness, Type 1 Weir,
Discharge 283 cu m/sec (10,000 cfs)

Sta	Baseline Water-Surface EI	Type 1 Weir Water-Surface EI	Prototype Difference ft ¹
135+50	764.94	764.40	0.54
131+90	763.82	763.75	0.07
128+60	764.22	763.75	0.47
123+95	762.92	762.27	0.65
120+15	762.56	761.99	0.58
116+50	762.42	762.06	0.36
113+50	762.53	761.30	1.23
112+00	761.88	761.09	0.79
110+00	762.10	761.38	0.72
108+00	762.06	761.12	0.94
106+00	761.77	760.80	0.97
104+00	761.67	760.77	0.90
102+00	760.98	760.04	0.94

¹ To convert prototype differences to millimeters, multiply by 304.8.

Table 32
Water-Surface Elevations, with Roughness, Type 1 Weir,
Discharge 566 cu m/sec (20,000 cfs)

Sta	Baseline Water-Surface EI	Type 1 Weir Water-Surface EI	Prototype Difference ft ¹
135+50	770.73	768.57	2.16
131+90	770.30	767.78	2.52
128+60	770.34	767.71	2.63
123+95	770.23	765.62	4.61
120+15	769.15	765.15	0.58
116+50	769.84	764.94	4.90
113+50	769.33	764.40	1.23
112+00	769.04	764.18	4.86
110+00	769.19	764.36	4.83
108+00	768.97	764.22	4.75
106+00	768.65	764.00	4.65
104+00	768.87	763.83	5.04
102+00	768.61	762.81	5.80

¹ To convert prototype differences to meters, multiply by 0.3048.

Table 33
Water-Surface Elevations, with Roughness, Type 1 Weir,
Discharge 991 cu m/sec (35,000 cfs)

Sta	Baseline Water-Surface EI	Type 1 Weir Water-Surface EI	Prototype Difference ft ¹
135+50	777.00	771.99	5.01
131+90	777.25	771.49	5.76
128+60	777.61	771.38	6.23
123+95	777.07	769.51	7.56
120+15	776.82	769.22	7.60
116+50	776.60	769.01	7.59
113+50	776.60	767.89	8.71
112+00	776.39	767.96	8.43
110+00	776.46	768.14	8.32
108+00	776.31	767.93	8.38
106+00	776.21	767.82	8.39
104+00	776.28	767.64	8.64
102+00	775.95	766.70	9.25

¹ To convert prototype differences to meters, multiply by 0.3048.

Table 34
Water-Surface Elevations, with Roughness, Type 1 Weir,
Discharge 1,557 cu m/sec (55,000 cfs)

Sta	Baseline Water-Surface EI	Type 1 Weir Water-Surface EI	Prototype Difference ft ¹
135+50	780.24	774.98	5.26
131+90	780.42	774.80	5.62
128+60	780.49	774.77	5.72
123+95	780.42	773.51	6.91
120+15	780.27	773.18	7.09
116+50	780.10	772.97	7.13
113+50	779.95	772.32	7.63
112+00	779.70	772.07	7.63
110+00	779.84	772.14	7.70
108+00	779.66	771.85	7.81
106+00	779.66	771.81	7.85
104+00	779.88	771.82	8.06
102+00	779.77	771.02	8.75

¹ To convert prototype differences to meters, multiply by 0.3048.

Table 35
Water-Surface Elevations, with Roughness, Type 1 Weir,
Discharge 2,265 cu m/sec (80,000 cfs)

Sta	Baseline Water-Surface El	Type 1 Weir Water-Surface El	Prototype Difference ft ¹
135+50	782.11	777.65	4.46
131+90	782.50	777.75	4.75
128+60	782.97	777.72	5.25
123+95	782.61	776.93	5.68
120+15	782.36	776.75	5.61
116+50	782.18	776.50	5.68
113+50	782.25	776.35	5.90
112+00	782.07	775.88	6.19
110+00	782.15	776.03	6.12
108+00	781.93	775.77	6.16
106+00	781.89	775.74	6.15
104+00	782.08	775.74	6.34
102+00	781.89	775.23	6.66

¹ To convert prototype differences to meters, multiply by 0.3048.

Table 36
Water-Surface Elevations, with Roughness, Type 14 Weir,
Discharge 28 cu m/sec (1,000 cfs)

Sta	Baseline Water-Surface EI	Type 14 Weir Water-Surface EI	Prototype Difference ft ¹
144+00		746.76	
135+50	745.28	745.71	-0.43
131+90	745.21	745.50	-0.29
128+60	745.46	745.46	0.00
123+95	744.96	745.10	-0.14
120+15	744.45	744.71	-0.26
116+50	744.06	744.24	-0.18
113+50	743.84	743.84	0.00
112+00	743.66	743.66	0.00
110+00	743.70	743.66	0.04
108+00	743.27	743.55	-0.28
106+00	743.05	743.12	-0.07
104+00	743.24	743.27	-0.03
102+00	742.94	743.26	-0.32

¹ To convert prototype difference to millimeters, multiply by 304.8.

Table 37
Water-Surface Elevations, with Roughness, Type 14 Weir,
Discharge 57 cu m/sec (2,000 cfs)

Sta	Baseline Water-Surface EI	Type 14 Weir Water-Surface EI	Prototype Difference ft ¹
144+00		751.04	
135+50	749.53	750.07	-0.54
131+90	749.28	749.96	-0.68
128+60	749.53	750.03	-0.50
123+95	749.13	749.75	-0.62
120+15	748.85	749.64	-0.79
116+50	748.52	749.46	-0.94
113+50	748.34	749.21	-0.87
112+00	748.23	749.10	-0.87
110+00	748.38	749.14	-0.76
108+00	748.16	749.03	-0.87
106+00	747.91	748.85	-0.94
104+00	748.06	748.92	-0.86
102+00	747.87	749.02	-1.15

¹ To convert prototype difference to millimeters, multiply by 304.8.

Table 38
Water-Surface Elevations, with Roughness, Type 14 Weir,
Discharge 142 cu m/sec (5,000 cfs)

Sta	Baseline Water-Surface EI	Type 14 Weir Water-Surface EI	Prototype Difference ft ¹
144+00		758.21	
135+50	756.30	756.84	-0.54
131+90	755.83	756.51	-0.68
128+60	756.12	756.62	-0.50
123+95	755.83	756.41	-0.58
120+15	755.69	756.37	-0.68
116+50	755.29	756.16	-0.87
113+50	755.07	755.79	-0.72
112+00	754.82	755.54	-0.72
110+00	755.00	755.62	-0.62
108+00	754.79	755.54	-0.75
106+00	754.46	755.22	-0.76
104+00	754.40	755.40	-1.00
102+00	754.24	755.40	-1.16

¹ To convert prototype difference to millimeters, multiply by 304.8.

Table 39
Water-Surface Elevations, with Roughness, Type 14 Weir,
Discharge 283 cu m/sec (10,000 cfs)

Sta	Baseline Water-Surface El	Type 14 Weir Water-Surface El	Prototype Difference ft ¹
144+00			
135+50	764.94	764.83	0.11
131+90	763.82	764.22	-0.40
128+60	764.22	764.25	-0.03
123+95	762.92	764.18	-1.26
120+15	762.56	764.15	-1.59
116+50	762.42	763.79	-1.37
113+50	762.53	763.25	-0.72
112+00	761.88	763.10	-1.22
110+00	762.10	763.18	-1.08
108+00	762.06	763.03	-0.97
106+00	761.77	762.53	-0.76
104+00	761.67	762.75	-1.08
102+00	760.98	762.63	-1.65

¹ To convert prototype difference to millimeters, multiply by 304.8.

Table 40
Water-Surface Elevations, with Roughness, Type 14 Weir,
Discharge 566 cu m/sec (20,000 cfs)

Sta	Baseline Water-Surface El	Type 14 Weir Water-Surface El	Prototype Difference ft ¹
144+00	771.71	771.17	0.54
135+50	770.73	770.12	0.61
131+90	770.30	769.58	0.72
128+60	770.34	769.51	0.83
123+95	770.23	769.44	0.79
120+15	769.15	769.44	0.58
116+50	769.84	769.04	0.80
113+50	769.33	768.61	1.23
112+00	769.04	768.39	0.65
110+00	769.19	768.36	0.83
108+00	768.97	768.29	0.68
106+00	768.65	767.82	0.83
104+00	768.87	768.08	0.79
102+00	768.61	767.92	0.69

¹ To convert prototype difference to millimeters, multiply by 304.8.

Table 41
Water-Surface Elevations, with Roughness, Type 14 Weir,
Discharge 991 cu m/sec (35,000 cfs)

Sta	Baseline Water-Surface El	Type 14 Weir Water-Surface El	Prototype Difference ft ¹
144+00		777.50	
135+50	777.00	776.75	0.25
131+90	777.25	776.82	0.43
128+60	777.61	776.85	0.76
123+95	777.07	776.67	0.40
120+15	776.82	776.64	0.18
116+50	776.60	776.39	0.21
113+50	776.60	776.24	0.36
112+00	776.39	776.06	0.33
110+00	776.46	776.03	0.43
108+00	776.31	775.85	0.46
106+00	776.21	775.70	0.51
104+00	776.28	775.92	0.36
102+00	775.95	775.84	0.11

¹ To convert prototype difference to millimeters, multiply by 304.8.

Table 42
Water-Surface Elevations, with Roughness, Type 14 Weir,
Discharge 1,557 cu m/sec (55,000 cfs)

Sta	Baseline Water-Surface El	Type 14 Weir Water-Surface El	Prototype Difference ft ¹
144+00	780.96	779.70	1.26
135+50	780.24	778.94	1.30
131+90	780.42	779.05	1.37
128+60	780.49	779.12	1.37
123+95	780.42	779.01	1.41
120+15	780.27	778.87	1.40
116+50	780.10	778.69	1.41
113+50	779.95	778.19	1.76
112+00	779.70	778.40	1.30
110+00	779.84	779.09	0.75
108+00	779.66	778.22	1.44
106+00	779.66	778.15	1.51
104+00	779.88	778.37	1.51
102+00	779.77	778.33	1.44

¹ To convert prototype difference to meters, multiply by 0.3048.

Table 43
Water-Surface Elevations, with Roughness, Type 14 Weir,
Discharge 1,840 cu m/sec (65,000 cfs)

Sta	Baseline Water-Surface El	Type 14 Weir Water-Surface El	Prototype Difference ft ¹
144+00		780.28	
135+50	780.92	779.48	1.44
131+90	781.32	779.66	1.66
128+60	781.71	779.66	2.05
123+95	781.35	779.59	1.76
120+15	781.10	779.45	1.65
116+50	780.89	779.16	1.73
113+50	780.99	779.19	1.80
112+00	780.78	778.94	1.84
110+00	780.89	778.98	1.91
108+00	780.60	778.87	1.73
106+00	780.63	778.73	1.90
104+00	780.75	779.02	1.73
102+00	780.60	778.94	1.66

¹ To convert prototype difference to meters, multiply by 0.3048.

Table 44
Water-Surface Elevations, with Roughness, Type 14 Weir,
Discharge 2,265 cu m/sec (80,000 cfs)

Sta	Baseline Water-Surface El	Type 14 Weir Water-Surface El	Prototype Difference ft ¹
144+00		780.67	
135+50	782.11	779.91	2.20
131+90	782.50	780.02	2.48
128+60	782.97	780.06	2.91
123+95	782.61	780.06	2.55
120+15	782.36	779.84	2.52
116+50	782.18	779.59	2.59
113+50	782.25	779.63	2.62
112+00	782.07	779.41	2.66
110+00	782.15	779.38	2.77
108+00	781.93	779.30	2.63
106+00	781.89	779.16	2.73
104+00	782.08	779.42	2.66
102+00	781.89	779.41	2.48

¹ To convert prototype difference to meters, multiply by 0.3048.

Table 45
Water-Surface Elevations, with Roughness, Type 21 Weir and
Type 1 Levee, Discharge 28 cu m/sec (1,000 cfs)

Sta	Baseline Water-Surface El	Type 21 Weir Water-Surface El	Prototype Difference ft ¹
144+00			
135+50	745.28	745.79	-0.51
131+90	745.21	745.57	-0.36
128+60	745.46	745.50	-0.04
123+95	744.96	745.10	-0.14
120+15	744.45	744.71	-0.26
116+50	744.06	744.31	-0.25
113+50	743.84	743.91	-0.07
112+00	743.66	743.77	-0.11
110+00	743.70	743.74	-0.04
108+00	743.27	743.48	-0.21
106+00	743.05	743.23	-0.18
104+00	743.24	743.38	-0.14
102+00	742.94	743.44	-0.50

¹ To convert prototype difference to millimeters, multiply by 304.8.

Table 46
Water-Surface Elevations, with Roughness, Type 21 Weir and
Type 1 Levee, Discharge 57 cu m/sec (2,000 cfs)

Sta	Baseline Water-Surface EI	Type 21 Weir Water-Surface EI	Prototype Difference ft ¹
		750.61	
135+50	749.53	749.57	-0.04
131+90	749.28	749.42	-0.14
128+60	749.53	749.53	0.00
123+95	749.13	749.21	-0.08
120+15	748.85	749.10	-0.25
116+50	748.52	748.74	-0.22
113+50	748.34	748.56	-0.22
112+00	748.23	748.49	-0.26
110+00	748.38	748.52	-0.14
108+00	748.16	748.41	-0.25
106+00	747.91	748.20	-0.29
104+00	748.06	748.31	-0.25
102+00	747.87	748.34	-0.47

¹ To convert prototype difference to millimeters, multiply by 304.8.

Table 47
Water-Surface Elevations, with Roughness, Type 21 Weir and
Type 1 Levee, Discharge 142 cu m/sec (5,000 cfs)

Sta	Baseline Water-Surface EI	Type 21 Weir Water-Surface EI	Prototype Difference ft ¹
144+00		758.14	
135+50	756.30	756.73	-0.43
131+90	755.83	756.33	-0.50
128+60	756.12	756.41	-0.29
123+95	755.83	756.19	-0.36
120+15	755.69	756.08	-0.39
116+50	755.29	755.87	-0.58
113+50	755.07	755.47	-0.40
112+00	754.82	755.25	-0.43
110+00	755.00	755.33	-0.33
108+00	754.79	755.18	-0.39
106+00	754.46	754.82	-0.36
104+00	754.40	755.01	-0.61
102+00	754.24	755.00	-0.76

¹ To convert prototype difference to millimeters, multiply by 304.8.

Table 48
Water-Surface Elevations, with Roughness, Type 21 Weir and
Type 1 Levee, Discharge 283 cu m/sec (10,000 cfs)

Sta	Baseline Water-Surface El	Type 21 Weir Water-Surface El	Prototype Difference ft ¹
144+00		766.78	
135+50	764.94	765.12	-0.18
131+90	763.82	764.32	-0.50
128+60	764.22	764.40	-0.18
123+95	762.92	764.18	-1.26
120+15	762.56	764.18	-1.62
116+50	762.42	763.82	-1.40
113+50	762.53	763.25	-0.72
112+00	761.88	763.10	-1.22
110+00	762.10	763.00	-0.90
108+00	762.06	762.96	-0.90
106+00	761.77	762.45	-0.68
104+00	761.67	762.64	-0.97
102+00	760.98	762.49	-1.51

¹ To convert prototype difference to millimeters, multiply by 304.8.

Table 49
Water-Surface Elevations, with Roughness, Type 21 Weir and
Type 1 Levee, Discharge 566 cu m/sec (20,000 cfs)

Sta	Baseline Water-Surface El	Type 21 Weir Water-Surface El	Prototype Difference ft ¹
144+00	771.71	770.99	0.72
135+50	770.73	769.94	0.79
131+90	770.30	769.36	0.94
128+60	770.34	769.40	0.94
123+95	770.23	769.22	1.01
120+15	769.15	769.22	-0.07
116+50	769.84	768.94	0.90
113+50	769.33	768.36	0.97
112+00	769.04	768.39	0.65
110+00	769.19	768.22	0.97
108+00	768.97	768.11	0.86
106+00	768.65	767.67	0.98
104+00	768.87	767.86	1.01
102+00	768.61	767.82	0.79

¹ To convert prototype difference to millimeters, multiply by 304.8.

Table 50
Water-Surface Elevations, with Roughness, Type 21 Weir and
Type 1 Levee, Discharge 991 cu m/sec (35,000 cfs)

Sta	Baseline Water-Surface EI	Type 21 Weir Water-Surface EI	Prototype Difference ft ¹
144+00		776.93	
135+50	777.00	776.13	0.87
131+90	777.25	776.17	1.08
128+60	777.61	776.21	1.40
123+95	777.07	775.99	1.08
120+15	776.82	775.95	0.87
116+50	776.60	775.60	1.00
113+50	776.60	775.49	1.11
112+00	776.39	775.31	1.08
110+00	776.46	775.24	1.22
108+00	776.31	775.09	1.22
106+00	776.21	774.87	1.34
104+00	776.28	775.10	1.18
102+00	775.95	775.05	0.90

¹ To convert prototype difference to meters, multiply by 0.3048.

Table 51
Water-Surface Elevations, Unconfined Flow, Type 23 Weir,
Discharge 28 cu m/sec (1,000 cfs)

Sta	Baseline Water-Surface El	Type 23 Weir Water-Surface El	Prototype Difference ft ¹
144+00	-	747.05	-
135+50	745.28	746.00	-0.72
131+90	745.21	745.78	-0.57
128+60	745.46	745.71	-0.25
123+95	744.96	745.39	-0.43
120+15	744.46	745.11	-0.65
116+50	744.06	744.49	-0.43
113+50	743.84	744.23	-0.39
112+00	743.66	744.17	-0.51
110+00	743.70	743.95	-0.25
108+00	743.27	743.91	-0.64
106+00	743.05	743.45	-0.40
104+00	743.24	743.63	-0.39
102+00	742.94	743.62	-0.68

¹ To convert prototype difference to millimeters, multiply by 304.8.

Table 52
Water-Surface Elevations, Unconfined Flow, Type 23 Weir,
Discharge 57 cu m/sec (2,000 cfs)

Sta	Baseline Water-Surface EI	Type 23 Weir Water-Surface EI	Prototype Difference ft ¹
144+00	-	750.86	-
135+50	749.53	749.85	-0.32
131+90	749.28	749.78	-0.50
128+60	749.53	749.82	-0.29
123+95	749.13	749.57	-0.44
120+15	748.85	749.61	-0.76
116+50	748.52	749.14	-0.62
113+50	748.34	749.13	-0.79
112+00	748.23	748.70	-0.47
110+00	748.38	748.96	-0.58
108+00	748.16	748.88	-0.72
106+00	747.91	748.67	-0.76
104+00	748.06	748.82	-0.76
102+00	747.87	748.84	-0.97

¹ To convert prototype difference to millimeters, multiply by 304.8.

Table 53
Water-Surface Elevations, Unconfined Flow, Type 23 Weir,
Discharge 142 cu m/sec (5,000 cfs)

Sta	Baseline Water-Surface El	Type 23 Weir Water-Surface El	Prototype Difference ft ¹
144+00	-	757.88	-
135+50	756.30	756.48	-0.18
131+90	755.83	756.15	-0.32
128+60	756.12	756.19	-0.07
123+95	755.83	756.05	-0.22
120+15	755.69	756.02	-0.33
116+50	755.29	755.62	-0.33
113+50	755.07	755.39	-0.32
112+00	754.82	755.22	-0.40
110+00	755.00	755.04	-0.04
108+00	754.79	755.00	-0.21
106+00	754.46	754.61	-0.15
104+00	754.40	754.76	-0.36
102+00	754.24	754.39	-0.15

¹ To convert prototype difference to millimeters, multiply by 304.8.

Table 54
Water-Surface Elevations, Unconfined Flow, Type 23 Weir,
Discharge 283 cu m/sec (10,000 cfs)

Sta	Baseline Water-Surface EI	Type 23 Weir Water-Surface EI	Prototype Difference ft ¹
144+00	-	766.60	-
135+50	764.94	764.83	0.11
131+90	763.82	764.11	-0.29
128+60	764.22	764.11	0.11
123+95	762.92	763.97	-1.05
120+15	762.56	764.08	-1.52
116+50	762.42	763.50	-1.08
113+50	762.53	762.95	-0.42
112+00	761.88	762.81	-0.93
110+00	762.10	762.74	-0.64
108+00	762.06	762.56	-0.50
106+00	761.77	761.99	-0.22
104+00	761.67	762.32	-0.65
102+00	760.98	761.84	-0.86

¹ To convert prototype difference to millimeters, multiply by 304.8.

Table 55
Water-Surface Elevations, Unconfined Flow, Type 23 Weir,
Discharge 566 cu m/sec (20,000 cfs)

Sta	Baseline Water-Surface EI	Type 23 Weir Water-Surface EI	Prototype Difference ft ¹
144+00	-	771.38	-
135+50	770.73	770.23	0.50
131+90	770.30	769.69	0.61
128+60	770.34	769.69	0.65
123+95	770.23	769.58	0.65
120+15	769.15	769.77	-0.62
116+50	769.84	769.26	0.58
113+50	769.33	768.93	0.40
112+00	769.04	768.86	0.18
110+00	769.19	768.61	0.58
108+00	768.97	768.57	0.40
106+00	768.65	768.18	0.47
104+00	768.87	768.47	0.40
102+00	768.61	768.28	0.33

¹ To convert prototype difference to millimeters, multiply by 304.8.

Table 56
Water-Surface Elevations, Unconfined Flow, Type 23 Weir,
Discharge 991 cu m/sec (35,000 cfs)

Sta	Baseline Water-Surface El	Type 23 Weir Water-Surface El	Prototype Difference ft ¹
144+00	-	777.18	-
135+50	777.00	776.39	0.61
131+90	777.25	776.42	0.83
128+60	777.61	776.39	1.22
123+95	777.07	776.35	0.72
120+15	776.82	776.36	0.46
116+50	776.60	775.96	0.64
113+50	776.60	775.77	0.83
112+00	776.39	775.74	0.65
110+00	776.46	775.45	1.01
108+00	776.31	775.23	1.08
106+00	776.21	775.16	1.05
104+00	776.28	775.46	0.82
102+00	775.95	775.27	0.68

¹ To convert prototype difference to millimeters, multiply by 304.8.

Table 57
Water-Surface Elevations, Unconfined Flow, Type 23 Weir,
Discharge 1,557 cu m/sec (55,000 cfs)

Sta	Baseline Water-Surface El	Type 23 Weir Water-Surface El	Prototype Difference ft ¹
144+00	-	778.91	-
135+50	780.24	778.44	1.80
131+90	780.42	778.29	2.13
128+60	780.49	778.26	2.23
123+95	780.42	778.19	2.23
120+15	780.27	778.38	1.89
116+50	780.10	777.76	2.34
113+50	779.95	777.96	1.99
112+00	779.70	778.04	1.66
110+00	779.84	777.40	2.44
108+00	779.66	777.18	2.48
106+00	779.66	777.11	2.55
104+00	779.88	777.44	2.44
102+00	779.77	777.50	2.27

¹ To convert prototype difference to meters, multiply by 0.3048.

Table 58
Water-Surface Elevations, Unconfined Flow, Type 23 Weir,
Discharge 1,840 cu m/sec (65,000 cfs)

Sta	Baseline Water-Surface El	Type 23 Weir Water-Surface El	Prototype Difference ft ¹
144+00	-	780.02	-
135+50	780.92	779.27	1.65
131+90	781.32	779.37	1.95
128+60	781.71	779.37	2.34
123+95	781.35	779.30	2.05
120+15	781.10	779.35	1.75
116+50	780.89	778.87	2.02
113+50	780.99	779.01	1.98
112+00	780.78	778.83	1.95
110+00	780.89	778.58	2.31
108+00	780.60	778.47	2.13
106+00	780.63	778.37	2.26
104+00	780.75	778.70	2.05
102+00	780.60	778.58	2.02

¹ To convert prototype difference to meters, multiply by 0.3048.

Table 59
Water-Surface Elevations, Unconfined Flow, Type 23 Weir,
Discharge 2,265 cu m/sec (80,000 cfs)

Sta	Baseline Water-Surface EI	Type 23 Weir Water-Surface EI	Prototype Difference ft ¹
144+00	-	780.28	-
135+50	782.11	779.91	2.20
131+90	782.50	779.73	2.77
128+60	782.97	779.77	3.20
123+95	782.61	779.66	2.95
120+15	782.36	779.74	2.62
116+50	782.18	779.20	2.98
113+50	782.25	781.06	1.19
112+00	782.07	779.41	2.66
110+00	782.15	779.27	2.88
108+00	781.93	778.83	3.10
106+00	781.89	778.76	3.13
104+00	782.08	779.13	2.95
102+00	781.89	779.23	2.66

¹ To convert prototype difference to meters, multiply by 0.3048.

Table 60
Water-Surface Elevations, Unconfined Flow, Type 25 Weir,
Discharge 1,557 cu m/sec (55,000 cfs)

Sta	Baseline Water-Surface El	Type 25 Weir Water-Surface El	Prototype Difference ft ¹
144+00	-	778.91	-
135+50	780.24	778.51	1.73
131+90	780.42	778.18	2.24
128+60	780.49	778.26	2.23
123+95	780.42	778.15	2.27
120+15	780.27	778.12	2.15
116+50	780.10	777.68	2.42
113+50	779.95	777.64	2.31
112+00	779.70	777.57	2.13
110+00	779.84	777.43	2.41
108+00	779.66	777.07	2.59
106+00	779.66	776.93	2.73
104+00	779.88	777.40	2.48
102+00	779.77	777.36	2.41

¹ To convert prototype difference to meters, multiply by 0.3048.

Table 61
Water-Surface Elevations, Unconfined Flow, Type 25 Weir,
Discharge 2,265 cu m/sec (80,000 cfs)

Sta	Baseline Water-Surface El	Type 25 Weir Water-Surface El	Prototype Difference ft ¹
144+00	-	780.24	-
135+50	782.11	779.23	2.88
131+90	782.50	779.62	2.88
128+60	782.97	779.73	3.24
123+95	782.61	779.70	2.91
120+15	782.36	779.82	2.54
116+50	782.18	779.23	2.95
113+50	782.25	777.89	4.36
112+00	782.07	778.51	3.56
110+00	782.15	779.16	2.99
108+00	781.93	778.87	3.06
106+00	781.89	778.76	3.13
104+00	782.08	779.16	2.92
102+00	781.89	779.41	2.48

¹ To convert prototype difference to meters, multiply by 0.3048.

Table 62
Type 23 Weir Calibration, Station 102+00, Discharge
991 cu m/sec (35,000 cfs)

Tailwater El	Water-Surface El
761.89	776.33
763.89	776.65
765.89	777.05
767.89	777.81
769.28	778.51
771.89	779.69
773.89	780.88

Table 63
Type 23 Weir Calibration, Station 102+00, Discharge
1,132 cu m/sec (40,000 cfs)

Tailwater El	Water-Surface El
761.89	776.96
763.89	777.28
765.89	777.68
767.89	778.36
769.89	779.16
771.89	780.09
773.89	781.28

Table 64
Type 23 Weir Calibration, Station 102+00, Discharge
1,557 cu m/sec (55,000 cfs)

Tailwater El	Water-Surface El
766.71	779.80
768.71	780.13
770.71	780.74
772.71	781.75
774.71	782.76

Table 65
Type 23 Weir Calibration, Station 102+00, Discharge
1,840 cu m/sec (65,000 cfs)

Tailwater El	Water-Surface El
769.28	781.35
771.28	781.93
773.28	782.79
775.28	784.02

Table 66
Type 25 Weir Calibration, Station 102+00, Discharge
991 cu m/sec (35,000 cfs)

Tailwater El	Water-Surface El
761.89	774.63
763.89	775.10
765.89	775.89
767.89	776.76
769.89	777.83
771.89	779.03
773.89	780.37

Table 67
Type 25 Weir Calibration, Station 102+00, Discharge
1,132 cu m/sec (40,000 cfs)

Tailwater El	Water-Surface El
761.89	775.09
763.89	775.56
765.89	776.35
767.89	777.18
769.89	778.18
771.89	779.37
773.89	780.70

Table 68
Type 25 Weir Calibration, Station 102+00, Discharge
1,557 cu m/sec (55,000 cfs)

Tailwater El	Water-Surface El
766.71	778.04
768.71	778.69
770.71	779.66
772.71	780.88

Table 69
Type 25 Weir Calibration, Station 102+00, Discharge
1,840 cu m/sec (65,000 cfs)

Tailwater El	Water-Surface El
769.28	779.84
771.28	780.49
773.28	781.68

Table 70
Type 23 Weir Calibration

Total Discharge		Tailwater El	Flow over Weir	
cu m/sec	cfs		cu m/sec	cfs
1,557	55,000	776.71	1,042	36,800
1,840	65,000	769.28	1,016	35,900
2,265	80,000	772.78	991	35,000

Table 71
Type 25 Weir Calibration

Total Discharge		Tailwater El	Flow over Weir	
cu m/sec	cfs		cu m/sec	cfs
1,557	55,000	776.71	1,356	47,900
1,840	65,000	769.28	1,345	47,500
2,265	80,000	772.78	1,050	37,100

Table 72
Velocities at Byram's Ford, Existing Conditions, Discharge
991 cu m/sec (35,000 cfs)

Distance from Channel Center Line ft	Bottom Velocity fps
Sta 112+00	
18 RT	3.6
36 RT	3.9
54 RT	4.5
72 RT	4.3
CL	3.7
18 LT	1.0
36 LT	3.3
54 LT	2.1
72 LT	1.8
Sta 113+50	
59.4 RT	3.1
41.4 RT	3.0
23.4 RT	3.3
18 RT	2.3
CL	3.5
18 LT	2.5
23.4 LT	2.2
41.4 LT	3.3
59.4 LT	3.2
77.4 LT	3.2
95.4	3.0
Note: To convert feet to meters, multiply by 0.3048. RT = right; CL = center line; LT = left.	

Table 73
Velocities at Byram's Ford, Existing Conditions, Discharge
1,557 cu m/sec (55,000 cfs)

Distance from Channel Center Line ft	Bottom Velocity fps
Sta 112+00	
72 RT	4.7
54 RT	4.2
36 RT	3.7
18 RT	3.8
CL	4.2
18 LT	4.6
36 LT	1.0
54 LT	2.0
72 LT	1.9
Sta 113+50	
59.4 RT	3.1
41.4 RT	3.0
23.4 RT	2.9
18 RT	3.4
CL	3.6
18 LT	4.0
23.4 LT	2.2
41.4 LT	2.2
59.4 LT	3.3
77.4 LT	3.2
95.4 LT	3.8
Note: To convert feet to meters, multiply by 0.3048. RT = right; CL = center line; LT = left.	

Table 74
Velocities at Byram's Ford, Unconfined Flow, Type 23 Weir,
Discharge 28 cu m/sec (1,000 cfs)

Distance from Channel Center Line ft	Bottom Velocity fps
Sta 112+00	
RT TOE	2.9
5 RT	3.9
10 RT	4.2
15 RT	3.9
20 RT	3.6
25 RT	3.6
30 RT	3.3
CL	2.7
5 LT	2.3
10 LT	1.7
15 LT	1.4
20 LT	1.2
25 LT	-
30 LT	-
LT TOE	-
Sta 113+50	
RT TOE	4.3
5 RT	4.2
10 RT	3.8
15 RT	3.5
CL	3.3
5 LT	2.1
10 LT	1.6
15 LT	1.3
20 LT	1.0
LT TOE	-
<p>Note: To convert feet to meters, multiply by 0.3048. RT = right; CL = center line; LT = left.</p>	

Table 75
Velocities at Byram's Ford, Unconfined Flow, Type 23 Weir,
Discharge 57 cu m/sec (2,000 cfs)

Distance from Channel Center Line ft	Bottom Velocity fps
Sta 112+00	
RT TOE	3.5
5 RT	3.5
10 RT	3.6
15 RT	3.5
20 RT	3.4
25 RT	3.2
30 RT	2.8
CL	2.2
5 LT	1.7
10 LT	1.3
15 LT	1.0
20 LT	1.0
25 LT	1.0
30 LT	1.0
LT TOE	-
Sta 113+50	
RT TOE	4.0
5 RT	4.4
10 RT	4.3
15 RT	4.4
20 RT	4.0
CL	3.9
5 LT	3.3
10 LT	2.4
15 LT	2.2
20 LT	1.0
LT TOE	-
Note: To convert feet to meters, multiply by 0.3048. RT = right; CL = center line; LT = left.	

Table 76
Velocities at Byram's Ford, Unconfined Flow, Type 23 Weir,
Discharge 142 cu m/sec (5,000 cfs)

Distance from Channel Center Line ft	Bottom Velocity fps
Sta 112+00	
RT TOE	3.6
5 RT	3.9
10 RT	3.5
15 RT	3.5
20 RT	3.6
25 RT	3.6
30 RT	3.6
CL	3.6
5 LT	3.7
10 LT	3.3
15 LT	2.7
20 LT	1.6
25 LT	1.0
30 LT	1.0
LT TOE	-
Sta 113+50	
RT TOE	4.3
5 RT	4.9
10 RT	4.2
15 RT	4.0
20 RT	4.0
CL	3.9
5 LT	3.8
10 LT	3.8
15 LT	3.9
20 LT	3.9
LT TOE	-

Note: To convert feet to meters, multiply by 0.3048. RT = right; CL = center line; LT = left.

Table 77
Velocities at Byram's Ford, Unconfined Flow, Type 23 Weir,
Discharge 283 cu m/sec (10,000 cfs)

Distance from Channel Center Line ft	Bottom Velocity fps
Sta 112+00	
RT TOE	6.0
5 RT	6.2
10 RT	6.3
15 RT	6.4
20 RT	6.6
25 RT	6.4
30 RT	6.1
CL	5.6
5 LT	4.9
10 LT	4.7
15 LT	3.9
20 LT	2.1
25 LT	1.0
30 LT	1.4
LT TOE	-
Sta 113+50	
RT TOE	6.7
5 RT	6.8
10 RT	7.5
15 RT	7.3
20 RT	7.3
CL	7.4
5 LT	7.4
10 LT	6.9
15 LT	6.5
20 LT	5.3
LT TOE	-
Note: To convert feet to meters, multiply by 0.3048. RT = right; CL = center line; LT = left.	

Table 78
Velocities at Byram's Ford, Unconfined Flow, Type 23 Weir,
Discharge 566 cu m/sec (20,000 cfs)

Distance from Channel Center Line ft	Bottom Velocity fps
Sta 112+00	
RT TOE	5.0
5 RT	5.5
10 RT	5.5
15 RT	5.6
20 RT	5.8
25 RT	4.3
30 RT	5.8
CL	5.2
5 LT	5.0
10 LT	4.6
15 LT	4.0
20 LT	2.5
25 LT	1.0
30 LT	1.3
LT TOE	-
Sta 113+50	
RT TOE	6.5
5 RT	5.8
10 RT	5.9
15 RT	6.4
20 RT	6.5
CL	6.7
5 LT	6.5
10 LT	6.1
15 LT	4.5
20 LT	1.0
LT TOE	-

Note: To convert feet to meters, multiply by 0.3048. RT = right; CL = center line; LT = left.

Table 79**Velocities at Byram's Ford, Unconfined Flow, Type 23 Weir,
Discharge 991 cu m/sec (35,000 cfs)**

Distance from Channel Center Line ft	Bottom Velocity fps
Sta 112+00	
RT TOE	4.6
5 RT	4.5
10 RT	4.5
15 RT	4.7
20 RT	4.7
25 RT	4.5
30 RT	4.5
CL	4.4
5 LT	4.4
10 LT	4.1
15 LT	3.5
20 LT	2.8
25 LT	1.0
30 LT	1.0
LT TOE	-
Sta 113+50	
RT TOE	4.9
5 RT	4.9
10 RT	4.8
15 RT	5.0
20 RT	5.2
CL	5.2
5 LT	5.1
10 LT	4.8
15 LT	3.3
20 LT	1.0
LT TOE	-
Note: To convert feet to meters, multiply by 0.3048. RT = right; CL = center line; LT = left.	

Table 80
Velocities at Byram's Ford, Unconfined Flow, Type 23 Weir,
Discharge 1,557 cu m/sec (55,000 cfs)

Distance from Channel Center Line ft	Bottom Velocity fps
Sta 112+00	
RT TOE	4.3
5 RT	4.6
10 RT	5.0
15 RT	5.3
20 RT	5.5
25 RT	5.3
30 RT	5.4
CL	5.4
5 LT	5.3
10 LT	5.2
15 LT	3.3
20 LT	1.8
25 LT	1.6
30 LT	1.1
LT TOE	1.2
Sta 113+50	
RT TOE	5.1
5 RT	5.0
10 RT	5.2
15 RT	5.0
20 RT	5.2
CL	5.1
5 LT	5.2
10 LT	4.9
15 LT	4.9
20 LT	4.8
LT TOE	4.5
<p>Note: To convert feet to meters, multiply by 0.3048. RT = right; CL = center line; LT = left.</p>	

Table 81
Velocities at Byram's Ford, Unconfined Flow, Type 23 Weir,
Discharge 2,265 cu m/sec (80,000 cfs)

Distance from Channel Center Line ft	Bottom Velocity fps
Sta 112+00	
RT TOE	4.0
5 RT	4.0
10 RT	4.2
15 RT	4.5
20 RT	4.6
25 RT	4.6
30 RT	4.5
CL	4.5
5 LT	4.4
10 LT	4.5
15 LT	4.1
20 LT	2.7
25 LT	1.1
30 LT	1.1
LT TOE	1.1
Sta 113+50	
RT TOE	4.2
5 RT	4.2
10 RT	4.2
15 RT	4.2
20 RT	4.3
CL	4.4
5 LT	4.4
10 LT	4.4
15 LT	4.3
20 LT	4.4
LT TOE	1.0
Note: To convert feet to meters, multiply by 0.3048. RT = right; CL = center line; LT = left.	

Table 82
Velocities at Byram's Ford, Unconfined Flow, Type 24 Weir,
Discharge 991 cu m/sec (35,000 cfs)

Distance from Channel Center Line ft	Bottom Velocity fps
Sta 112+00	
RT TOE	4.7
5 RT	4.4
10 RT	4.9
15 RT	4.7
20 RT	4.8
25 RT	5.6
30 RT	5.4
CL	4.7
5 LT	4.5
10 LT	4.4
15 LT	3.4
20 LT	1.0
25 LT	1.0
30 LT	1.5
LT TOE	-
Sta 113+50	
RT TOE	5.8
5 RT	5.6
10 RT	5.6
15 RT	5.9
20 RT	5.6
CL	5.4
5 LT	5.3
10 LT	5.2
15 LT	1.3
20 LT	1.2
LT TOE	1.0

Note: To convert feet to meters, multiply by 0.3048. RT = right; CL = center line; LT = left.

Table 83
Velocities at Byram's Ford, Unconfined Flow, Type 25 Weir,
Discharge 991 cu m/sec (35,000 cfs)

Distance from Channel Center Line ft	Bottom Velocity fps
Sta 112+00	
RT TOE	5.1
5 RT	5.2
10 RT	5.1
15 RT	5.0
20 RT	5.5
25 RT	5.0
30 RT	5.2
CL	5.1
5 LT	5.2
10 LT	4.6
15 LT	4.1
20 LT	1.2
25 LT	1.1
30 LT	1.0
LT TOE	-
Sta 113+50	
RT TOE	5.3
5 RT	5.7
10 RT	5.4
15 RT	5.7
20 RT	5.8
CL	6.1
5 LT	5.5
10 LT	4.9
15 LT	4.1
20 LT	1.0
LT TOE	-

Note: To convert feet to meters, multiply by 0.3048. RT = right; CL = center line; LT = left.

Table 84
Velocities at Byram's Ford, Unconfined Flow, Type 25 Weir,
Discharge 1,557 cu m/sec (55,000 cfs)

Distance from Channel Center Line ft	Bottom Velocity fps
Sta 112+00	
RT TOE	4.9
5 RT	5.2
10 RT	5.4
15 RT	5.4
20 RT	5.4
25 RT	5.6
30 RT	5.5
CL	5.6
5 LT	5.3
10 LT	5.4
15 LT	4.0
20 LT	2.4
25 LT	1.8
30 LT	1.4
LT TOE	1.0
Sta 113+50	
RT TOE	4.6
5 RT	5.0
10 RT	4.8
15 RT	4.8
20 RT	4.9
CL	5.0
5 LT	4.9
10 LT	4.9
15 LT	5.0
20 LT	4.7
LT TOE	4.5

Note: To convert feet to meters, multiply by 0.3048. RT = right; CL = center line; LT = left.

Table 85
Velocities at Byram's Ford, Unconfined Flow, Type 25 Weir,
Discharge 2,265 cu m/sec (80,000 cfs)

Distance from Channel Center Line ft	Bottom Velocity fps
Sta 112+00	
RT TOE	4.6
5 RT	4.6
10 RT	4.5
15 RT	4.6
20 RT	4.4
25 RT	4.3
30 RT	4.5
CL	4.5
5 LT	4.3
10 LT	3.9
15 LT	2.8
20 LT	2.0
25 LT	1.7
30 LT	1.4
LT TOE	1.5
Sta 113+50	
RT TOE	3.8
5 RT	4.5
10 RT	4.3
15 RT	4.4
20 RT	4.4
CL	4.6
5 LT	4.6
10 LT	4.4
15 LT	4.6
20 LT	4.5
LT TOE	1.0

Note: To convert feet to meters, multiply by 0.3048. RT = right; CL = center line; LT = left.

Table 86
Bottom Velocities at Byram's Ford, Type 23 Weir (Unconfined Flow), Existing Conditions

Distance from Channel Center Line ft	Unconfined Flow								Existing Conditions	
	1,000 cfs	2,000 cfs	5,000 cfs	10,000 cfs	20,000 cfs	35,000 cfs	55,000 cfs	80,000 cfs	35,000 cfs	55,000 cfs
Sta 112+00										
36 RT	-	-	-	-	-	-	-	-	3.9	3.7
30 RT	3.3	2.8	3.6	6.1	5.8	4.5	5.4	4.5	-	-
25 RT	3.6	3.2	3.6	6.4	4.3	4.5	5.3	4.6	-	-
20 RT	3.6	3.4	3.6	6.6	5.8	4.7	5.5	4.6	-	-
18 RT	-	-	-	-	-	-	-	-	3.6	3.8
15 RT	3.9	3.5	3.5	6.4	5.6	4.7	5.3	4.5	-	-
10 RT	4.2	3.6	3.5	6.3	5.5	4.5	5.0	4.2	-	-
5 RT	3.9	3.5	3.9	6.2	5.5	4.5	4.6	4.0	-	-
CL	2.7	2.2	3.6	5.6	5.2	4.4	5.4	4.5	3.7	4.2
5 LT	2.3	1.7	3.7	4.9	5.0	4.4	5.3	4.4	-	-
10 LT	1.7	1.3	3.3	4.7	4.6	4.1	5.2	4.5	-	-
15 LT	1.4	1.0	2.7	3.9	4.0	3.5	3.3	4.1	-	-
18 LT	-	-	-	-	-	-	-	-	1.0	4.6
20 LT	1.2	1.0	1.6	2.1	2.5	2.8	1.8	2.7	-	-
25 LT	-	1.0	1.0	1.0	1.0	1.0	1.6	1.1	-	-
30 LT	-	1.0	1.0	1.4	1.3	1.0	1.1	1.1	-	-
36 LT	-	-	-	-	-	-	-	-	3.3	1.0

(Continued)

Note: To convert flow in cfs to cu m/sec, multiply by 0.028.

Table 87
Bottom Velocities at Byram's Ford, Type 25 Weir (Unconfined Flow), Existing Conditions

Distance from Channel Center Line ft	Unconfined Flow								Existing Conditions	
	1,000 cfs	2,000 cfs	5,000 cfs	10,000 cfs	20,000 cfs	35,000 cfs	55,000 cfs	80,000 cfs	35,000 cfs	55,000 cfs
Sta 112+00										
30 RT	3.3	2.8	3.6	6.1	5.8	5.2	5.5	4.5		-
25 RT	3.6	3.2	3.6	6.4	4.3	5.0	5.6	4.3	-	-
20 RT	3.6	3.4	3.6	6.6	5.8	5.5	5.4	4.4	-	-
18 RT	-	-	-	-	-	-	-	-	3.6	3.8
15 RT	3.9	3.5	3.5	6.4	5.6	5.0	5.4	4.6	-	-
10 RT	4.2	3.6	3.5	6.3	5.5	5.1	5.4	4.5	-	-
5 RT	3.9	3.5	3.9	6.2	5.5	5.2	5.2	4.6	-	-
CL	2.7	2.2	3.6	5.6	5.2	5.1	5.6	4.5	3.7	4.2
5 LT	2.3	1.7	3.7	4.9	5.0	5.2	5.3	4.3	-	-
10 LT	1.7	1.3	3.3	4.7	4.6	4.6	5.4	3.9	-	-
15 LT	1.4	1.0	2.7	3.9	4.0	4.1	4.0	2.8	-	-
18 LT	-	-	-	-	-	-	-	-	1.0	4.6
20 LT	1.2	1.0	1.6	2.1	2.5	1.2	2.4	2.0	-	-
25 LT	-	1.0	1.0	1.0	1.0	1.1	1.8	1.7	-	-
30 LT	-	1.0	1.0	1.4	1.3	1.0	1.4	1.4	-	-
36 LT	-	-	-	-	-	-	-	-	3.3	1.0

(Continued)

Note: To convert flow in cfs to cu m/sec, multiply by 0.028.

Table 88
Bottom Velocities at Byram's Ford, Type 23 Weir and Existing Conditions

Distance from Channel Center Line ft	Confined Flow								Existing Conditions at 55,000 cfs
	1,000 cfs	2,000 cfs	5,000 cfs	10,000 cfs	20,000 cfs	55,000 cfs	65,000 cfs	80,000 cfs	
Sta 112+00									
36 RT	-	-	-	-	-	-	-	-	3.7
30 RT	3.3	2.8	3.6	6.1	5.8	3.6	3.6	3.4	-
25 RT	3.6	3.2	3.6	6.4	4.3	3.6	3.5	3.3	-
20 RT	3.6	3.4	3.6	6.6	5.8	3.7	3.5	3.5	-
18 RT	-	-	-	-	-	-	-	-	3.8
15 RT	3.9	3.5	3.5	6.4	5.6	3.7	3.5	3.3	-
10 RT	4.2	3.6	3.5	6.3	5.5	3.7	3.4	3.2	-
5 RT	3.9	3.5	3.9	6.2	5.5	3.8	3.7	3.4	-
CL	2.7	2.2	3.6	5.6	5.2	3.6	3.4	3.2	4.2
5 LT	2.3	1.7	3.7	4.9	5.0	3.7	3.6	3.3	-
10 LT	1.7	1.3	3.3	4.7	4.6	3.6	3.4	3.3	-
15 LT	1.4	1.0	2.7	3.9	4.0	3.3	3.4	3.2	-
18 LT	-	-	-	-	-	-	-	-	4.6
20 LT	1.2	1.0	1.6	2.1	2.5	2.9	3.2	3.2	-
25 LT	-	1.0	1.0	1.0	1.0	1.0	1.0	1.0	-
30 LT	-	1.0	1.0	1.4	1.3	1.0	1.6	1.4	-
36 LT	-	-	-	-	-	-	-	-	1.0

(Continued)

Note: To convert flow in cfs to cu m/sec, multiply by 0.028.

Table 89
Bottom Velocities at Byram's Ford, Type 25 Weir and Existing Conditions

Distance from Channel Center Line ft	Confined Flow								Existing Conditions	
	1,000 cfs	2,000 cfs	5,000 cfs	10,000 cfs	20,000 cfs	55,000 cfs	65,000 cfs	80,000 cfs	55,000 cfs	65,000 cfs
Sta 112+00										
36 RT	-	-	-	-	-	-	-	-	3.9	3.7
30 RT	3.3	2.8	3.6	6.1	5.8	5.1	3.5	3.9	-	-
25 RT	3.6	3.2	3.6	6.4	4.3	5.2	4.5	3.8	-	-
20 RT	3.6	3.4	3.6	6.6	5.8	5.2	4.5	3.9	-	-
18 RT	-	-	-	-	-	-	-	-	3.6	3.8
15 RT	3.9	3.5	3.5	6.4	5.6	5.2	4.4	3.7	-	-
10 RT	4.2	3.6	3.5	6.3	5.5	5.1	4.5	3.5	-	-
5 RT	3.9	3.5	3.9	6.2	5.5	5.2	4.5	3.6	-	-
CL	2.7	2.2	3.6	5.6	5.2	4.8	4.5	4.1	3.7	4.2
5 LT	2.3	1.7	3.7	4.9	5.0	4.7	4.3	3.9	-	-
10 LT	1.7	1.3	3.3	4.7	4.6	3.9	3.9	3.9	-	-
15 LT	1.4	1.0	2.7	3.9	4.0	1.2	3.7	3.7	-	-
18 LT	-	-	-	-	-	-	-	-	1.0	4.6
20 LT	1.2	1.0	1.6	2.1	2.5	1.2	1.1	1.3	-	-
25 LT	-	1.0	1.0	1.0	1.0	1.0	1.0	1.0	-	-
30 LT	-	1.0	1.0	1.4	1.3	1.7	1.0	1.2	-	-
36 LT	-	-	-	-	-	-	-	-	3.3	1.0

(Continued)

Note: To convert flow in cfs to cu m/sec, multiply by 0.028.

Table 90
Velocities at Byram's Ford, Confined Flow, Type 23 Weir,
Discharge 1,557 cu m/sec (55,000 cfs)

Distance from Channel Center Line ft	Bottom Velocity fps
Sta 112+00	
RT TOE	3.7
5 RT	3.8
10 RT	3.7
15 RT	3.7
20 RT	3.7
25 RT	3.6
30 RT	3.6
CL	3.6
5 LT	3.7
10 LT	3.6
15 LT	3.3
20 LT	2.9
25 LT	1.0
30 LT	1.0
LT TOE	-
Sta 113+50	
RT TOE	3.6
5 RT	3.5
10 RT	3.4
15 RT	3.7
20 RT	3.6
CL	3.7
5 LT	3.9
10 LT	3.7
15 LT	3.5
20 LT	2.2
LT TOE	-

Note: To convert feet to meters, multiply by 0.3048. RT = right; CL = center line; LT = left.

Table 91
Velocities at Byram's Ford, Confined Flow, Type 23 Weir,
Discharge 1,840 cu m/sec (65,000 cfs)

Distance from Channel Center Line ft	Bottom Velocity fps
Sta 112+00	
RT TOE	3.5
5 RT	3.7
10 RT	3.4
15 RT	3.5
20 RT	3.5
25 RT	3.5
30 RT	3.6
CL	3.4
5 LT	3.6
10 LT	3.4
15 LT	3.4
20 LT	3.2
25 LT	1.0
30 LT	1.6
LT TOE	-
Sta 113+50	
RT TOE	3.5
5 RT	3.3
10 RT	3.3
15 RT	3.3
20 RT	3.6
CL	3.4
5 LT	3.5
10 LT	3.4
15 LT	2.0
20 LT	1.0
LT TOE	-
Note: To convert feet to meters, multiply by 0.3048. RT = right; CL = center line; LT = left.	

Table 92
Velocities at Byram's Ford, Confined Flow, Type 23 Weir,
Discharge 2,265 cu m/sec (80,000 cfs)

Distance from Channel Center Line ft	Bottom Velocity fps
Sta 112+00	
RT TOE	3.4
5 RT	3.4
10 RT	3.2
15 RT	3.3
20 RT	3.5
25 RT	3.3
30 RT	3.4
CL	3.2
5 LT	3.3
10 LT	3.3
15 LT	3.2
20 LT	3.2
25 LT	1.0
30 LT	1.4
LT TOE	-
Sta 113+50	
RT TOE	3.5
5 RT	3.3
10 RT	3.3
15 RT	3.3
20 RT	3.6
CL	3.4
5 LT	3.5
10 LT	3.4
15 LT	2.0
20 LT	1.0
LT TOE	-

Note: To convert feet to meters, multiply by 0.3048. RT = right; CL = center line; LT = left.

Table 93
Velocities at Byram's Ford, Confined Flow, Type 24 Weir,
Discharge 1,557 cu m/sec (55,000 cfs)

Distance from Channel Center Line ft	Bottom Velocity fps
Sta 112+00	
RT TOE	4.2
5 RT	4.1
10 RT	4.1
15 RT	4.0
20 RT	4.1
25 RT	4.0
30 RT	4.0
CL	4.0
5 LT	3.9
10 LT	3.9
15 LT	3.0
20 LT	1.0
25 LT	1.0
30 LT	1.8
LT TOE	-
Sta 113+50	
RT TOE	4.2
5 RT	4.2
10 RT	4.2
15 RT	4.4
20 RT	4.3
CL	4.4
5 LT	4.1
10 LT	3.8
15 LT	2.4
20 LT	1.0
LT TOE	-

Note: To convert feet to meters, multiply by 0.3048. RT = right; CL = center line; LT = left.

Table 94
Velocities at Byram's Ford, Confined Flow, Type 24 Weir,
Discharge 1,840 cu m/sec (65,000 cfs)

Distance from Channel Center Line ft	Bottom Velocity fps
Sta 112+00	
RT TOE	3.8
5 RT	3.7
10 RT	3.7
15 RT	3.8
20 RT	3.7
25 RT	3.9
30 RT	3.8
CL	3.6
5 LT	3.8
10 LT	3.4
15 LT	3.1
20 LT	1.0
25 LT	1.2
30 LT	1.7
LT TOE	-
Sta 113+50	
RT TOE	3.8
5 RT	3.7
10 RT	3.8
15 RT	3.9
20 RT	4.1
CL	3.8
5 LT	3.9
10 LT	2.5
15 LT	2.3
20 LT	1.0
LT TOE	-

Note: To convert feet to meters, multiply by 0.3048. RT = right; CL = center line; LT = left.

Table 95
Velocities at Byram's Ford, Confined Flow, Type 24 Weir,
Discharge 2,265 cu m/sec (80,000 cfs)

Distance from Channel Center Line ft	Bottom Velocity fps
Sta 112+00	
RT TOE	3.5
5 RT	3.7
10 RT	3.7
15 RT	3.9
20 RT	3.8
25 RT	3.9
30 RT	3.8
CL	3.8
5 LT	3.8
10 LT	3.6
15 LT	3.3
20 LT	1.1
25 LT	1.0
30 LT	1.0
LT TOE	-
Sta 113+50	
RT TOE	3.5
5 RT	3.5
10 RT	3.7
15 RT	3.8
20 RT	3.8
CL	3.5
5 LT	3.6
10 LT	2.5
15 LT	1.9
20 LT	1.0
LT TOE	-
Note: To convert feet to meters, multiply by 0.3048. RT = right; CL = center line; LT = left.	

Table 96
Velocities at Byram's Ford, Confined Flow, Type 25 Weir,
Discharge 1,557 cu m/sec (55,000 cfs)

Distance from Channel Center Line ft	Bottom Velocity fps
Sta 112+00	
RT TOE	5.0
5 RT	5.2
10 RT	5.1
15 RT	5.2
20 RT	5.2
25 RT	5.2
30 RT	5.1
CL	4.8
5 LT	4.7
10 LT	3.9
15 LT	1.2
20 LT	1.2
25 LT	1.0
30 LT	1.7
LT TOE	-
Sta 113+50	
RT TOE	5.2
5 RT	5.1
10 RT	5.3
15 RT	5.3
20 RT	5.4
CL	5.3
5 LT	5.2
10 LT	5.0
15 LT	1.7
20 LT	1.0
LT TOE	-

Note: To convert feet to meters, multiply by 0.3048. RT = right; CL = center line; LT = left.

Table 97
Velocities at Byram's Ford, Confined Flow, Type 25 Weir,
Discharge 1,840 cu m/sec (65,000 cfs)

Distance from Channel Center Line ft	Bottom Velocity fps
Sta 112+00	
RT TOE	4.2
5 RT	4.5
10 RT	4.5
15 RT	4.4
20 RT	4.5
25 RT	4.5
30 RT	3.5
CL	4.5
5 LT	4.3
10 LT	3.9
15 LT	3.7
20 LT	1.1
25 LT	1.0
30 LT	1.0
LT TOE	-
Sta 113+50	
RT TOE	4.4
5 RT	4.2
10 RT	4.4
15 RT	4.4
20 RT	4.7
CL	4.4
5 LT	4.3
10 LT	3.4
15 LT	3.2
20 LT	1.0
LT TOE	-

Note: To convert feet to meters, multiply by 0.3048. RT = right; CL = center line; LT = left.

Table 98
Velocities at Byram's Ford, Confined Flow, Type 25 Weir,
Discharge 2,265 cu m/sec (80,000 cfs)

Distance from Channel Center Line ft	Bottom Velocity fps
Sta 112+00	
RT TOE	4.0
5 RT	3.6
10 RT	3.5
15 RT	3.7
20 RT	3.9
25 RT	3.8
30 RT	3.9
CL	4.1
5 LT	3.9
10 LT	3.9
15 LT	3.7
20 LT	1.3
25 LT	1.0
30 LT	1.2
LT TOE	-
Sta 113+50	
RT TOE	4.0
5 RT	3.7
10 RT	3.8
15 RT	3.9
20 RT	3.9
CL	3.7
5 LT	3.8
10 LT	2.4
15 LT	2.0
20 LT	1.0
LT TOE	-

Note: To convert feet to meters, multiply by 0.3048. RT = right; CL = center line; LT = left.

Table 99
Water-Surface Elevations, Type 25 Weir, Left Trail Levee,
Discharge 991 cu m/sec (35,000 cfs)

Distance Downstream of End Sill	Water-Surface El
0	759.03
50	759.89
100	760.65
150	761.40
200	761.40
250	761.01
300	758.52
350	758.63
400	758.41

Table 100
Water-Surface Elevations, Type 25 Weir, Left Trail Levee,
Discharge 1,557 cu m/sec (55,000 cfs)

Distance Downstream of End Sill	Water-Surface El
0	771.03
50	771.97
100	772.54
150	772.76
200	772.83
250	773.19
300	773.30
350	770.67
400	770.71

Table 101
Water-Surface Elevations, Type 25 Weir, Left Trail Levee,
Discharge 2,265 cu m/sec (80,000 cfs)

Distance Downstream of End Sill	Water-Surface El
0	775.70
50	776.53
100	777.28
150	777.36
200	777.43
250	777.57
300	775.27
350	775.16
400	775.27

Table 102
Overbank Water-Surface Elevations, Type 23 Weir, Discharge
1,557 cu m/sec (55,000 cfs)

Sta	Water-Surface EI	Sta	Water-Surface EI
Range 1		Range 2 (Continued)	
R1-1	775.5	R2-17	773.6
R1-3	775.7	Range 3	
R1-5	775.1	R3-5	776.5
R1-7	775.0	R3-7	774.4
R1-9	774.5	R3-9	775.6
R1-11	774.5	R3-11	775.0
R1-13	774.6	R3-13	774.3
Range 2		Range 4	
R2-3	775.5	R4-3	770.6
R2-5	775.5	R4-5	775.3
R2-7	774.9	R4-7	773.1
R2-9	774.6	R4-9	772.6
R2-11	774.6	R4-11	775.0
R2-13	774.4	R4-13	775.2
R2-15	774.6		

Table 103
Overbank Water-Surface Elevations, Type 23 Weir, Discharge
2,265 cu m/sec (80,000 cfs)

Sta	Water-Surface El	Sta	Water-Surface El
Range 1		Range 2 (Continued)	
R1-1	778.8	R2-17	776.3
R1-3	779.1	Range 3	
R1-5	778.5	R3-3	779.7
R1-7	777.8	R3-5	775.6
R1-9	777.8	R3-7	778.1
R1-11	777.3	R3-9	779.6
R1-13	777.3	R3-11	779.1
Range 2		R3-13	777.3
R2-3	778.7	Range 4	
R2-5	778.7	R4-3	774.3
R2-7	778.5	R4-5	777.8
R2-9	777.4	R4-7	778.4
R2-11	777.5	R4-9	776.8
R2-13	777.5	R4-11	777.2
R2-15	777.1	R4-13	776.0

Table 104
Overbank Water-Surface Elevations, Type 25 Weir, Discharge
1,557 cu m/sec (55,000 cfs)

Sta	Water-Surface EI	Sta	Water-Surface EI
Range 1		Range 2 (Continued)	
R1-1	775.4	R2-17	773.0
R1-3	775.7	Range 3	
R1-5	774.8	R3-3	776.2
R1-7	775.1	R3-5	775.5
R1-9	774.6	R3-7	774.4
R1-11	774.4	R3-9	776.1
R1-13	774.5	R3-11	775.5
Range 2		R3-13	773.5
R2-3	775.5	Range 4	
R2-5	775.5	R4-3	770.6
R2-7	775.0	R4-5	774.7
R2-9	774.6	R4-7	775.2
R2-11	774.6	R4-9	773.8
R2-13	776.1	R4-11	775.0
R2-15	775.4	R4-13	775.2

Table 105
Overbank Water-Surface Elevations, Type 25 Weir, Discharge
2,265 cu m/sec (80,000 cfs)

Sta	Water-Surface EI	Sta	Water-Surface EI
Range 1		Range 2 (Continued)	
R1-1	779.1	R2-17	776.0
R1-3	779.3	Range 3	
R1-5	778.4	R3-3	778.0
R1-7	777.9	R3-5	779.1
R1-9	777.8	R3-7	778.2
R1-11	777.3	R3-9	779.1
R1-13	777.5	R3-11	779.2
Range 2		R3-13	777.5
R2-3	779.6	Range 4	
R2-5	779.4	R4-3	774.4
R2-7	779.3	R4-5	777.9
R2-9	777.8	R4-7	778.1
R2-11	777.5	R4-9	776.8
R2-13	777.6	R4-11	776.7
R2-15	777.6	R4-13	776.0

Table 106
Left Overbank Velocities, Type 23 Weir, Discharge
1,557 cu m/sec (55,000 cfs), Tailwater El = 766.71

Range	Velocity, fps	Direction (Looking Downstream)
R1-1	1.1	7:00
R1-3	2.3	12:00
R1-5	3.3	12:00
R1-7	6.6	12:00
R1-9	1.3	12:00T
R1-11	1.5	12:00
R2-3	3.4	12:00
R2-5	2.9	1:00
R2-9	4.2	12:00
R2-11	2.6	12:00
R2-13	3.8	11:00
R2-15	5.3	12:00
R2-17	2.8	12:00
R3-2	1.1	11:00
R3-3	1.7	12:00
R3-5	1.2	2:00
R3-7	1.8	2:00
R4-1	4.4	11:00
R4-3	6.5	11:00
R4-5	1.7	1:00

Note: To convert feet per second to meters per second, multiply by 0.3048.

Table 107
Left Overbank Velocities, Type 23 Weir, Discharge
2,265 cu m/sec (80,000 cfs), Tailwater EI = 772.28

Range	Velocity, fps	Direction (Looking Downstream)
R1-1	2.2	3:00
R1-3	2.3	12:00
R1-5	3.4	12:00
R1-7	7.4	12:00
R1-9	3.2	12:00T
R1-11	3.2	11:00
R1-13	1.7	12:00
R2-3	5.3	11:00
R2-5	4.9	1:00
R2-7	6.8	12:00
R2-9	11.8	12:00
R2-11	7.2	12:00
R2-13	7.4	11:00
R2-15	7.0	11:00
R2-17	4.6	11:00
R3-3	2.7	12:00
R3-5	2.0	12:00
R3-7	1.1	2:00
R3-9	2.7	12:00
R3-11	1.1	3:00
R3-13	1.8	12:00
R3-15	1.1	6:00
R4-3	4.6	9:00
R4-5	1.3	11:00
R4-7	6.0	12:00
R4-9	4.1	9:00
R4-11	3.9	9:00
R4-13	SHALLOW	SHALLOW
R4-15	SHALLOW	SHALLOW

Note: To convert feet per second to meters per second, multiply by 0.3048

Table 108
Left Overbank Velocities, Type 25 Weir, Discharge
1,557 cu m/sec (55,000 cfs), Tailwater El = 766.71

Range	Velocity, fps	Direction (Looking Downstream)
R1-3	1.9	12:00
R1-5	3.4	12:00
R1-7	5.7	12:00
R1-9	1.1	12:00T
R1-11	1.1	12:00T
R1-13	SHALLOW	SHALLOW
R2-3	1.9	12:00
R2-5	1.2	12:00
R2-7	DRY	DRY
R2-9	SHALLOW	SHALLOW
R2-11	SHALLOW	SHALLOW
R2-13	SHALLOW	SHALLOW
R2-15	3.5	11:00
R2-17	4.7	12:00
R3-3	1.6	12:00
R3-5	1.4	2:00
R3-7	1.8	2:00
R4-3	4.3	11:00
R4-5	1.3	11:00T

Note: To convert feet per second to meters per second, multiply by 0.3048.

Table 109
Left Overbank Velocities, Type 25 Weir, Discharge
2,265 cu m/sec (80,000 cfs), Tailwater EI = 772.28

Range	Velocity, fps	Direction (Looking Downstream)
R1-1	1.7	3:00
R1-3	3.3	11:00
R1-5	3.8	11:00
R1-7	7.8	11:00
R1-9	6.3	9:00T
R1-11	6.3	12:00T
R1-13	1.9	11:00
R2-3	2.5	11:00
R2-5	4.2	12:00
R2-7	6.3	12:00
R2-9	8.2	12:00
R2-11	9.6	12:00
R2-13	7.1	12:00
R2-15	7.8	11:00
R2-17	7.4	11:00
R3-3	3.8	11:00
R3-5	1.9	11:00
R3-7	1.1	2:00
R3-9	3.9	12:00
R3-11	1.0	3:00
R3-13	2.3	12:00
R3-15	1.0	6:00
R4-3	4.2	11:00
R4-5	1.9	12:00
R4-7	7.3	12:00
R4-9	4.1	9:00
R4-11	6.1	9:00
R4-13	SHALLOW	SHALLOW
R4-15	SHALLOW	SHALLOW

Note: To convert feet per second to meters per second, multiply by 0.3048.

Table 110
Water-Surface Elevations, Breached Spoil Bank, Type 23 Weir,
Discharge 991 cu m/sec (35,000 cfs)

Sta	Water-Surface El		Prototype Difference ft ¹
	Baseline	Type 2 Weir	
144+00		775.70	
135+50	777.00	774.95	2.05
131+90	777.25	774.58	2.67
128+60	777.61	774.87	2.74
123+95	777.07	774.37	2.70
120+15	776.82	774.56	2.26
116+50	776.60	773.94	2.66
113+50	776.60	772.28	4.32
112+00	776.39	773.15	3.24
110+00	776.46	773.58	2.88
108+00	776.31	773.36	2.95
106+00	776.21	773.15	3.06
104+00	776.28	773.44	2.84
102+00	775.95	773.65	2.30

¹ To convert prototype difference to meters, multiply by 0.3048.

Table 111
Left Overbank Water-Surface Elevations, Breached Spoil Bank,
Type 23 Weir, Discharge 991 cu m/sec (35,000 cfs)

Sta	Water-Surface EI	Sta	Water-Surface EI
Range 1		Range 2 (Continued)	
R1-1	774.1	R2-15	773.5
R1-3	774.1	Range 3	
R1-5	773.5	R3-3	774.9
R1-7	773.3	R3-5	774.3
R1-9	773.5	R3-7	773.3
R1-11	773.3	R3-9	775.1
Range 2		R3-11	774.2
R2-3	774.6	R3-13	772.6
R2-5	774.2	Range 4	
R2-7	773.7	R4-3	768.9
R2-9	773.7	R4-5	774.3
R2-11	773.6	R4-7	773.7
R2-13	773.6	R4-9	773.7

Table 112
Velocities at Byram's Ford, Breached Spoil Bank, Type 23 Weir,
Discharge 991 cu m/sec (35,000 cfs)

Side	Distance from River Center Line ft	Bottom Velocity fps	Direction
Sta 112+00			
Right	TOE	5.9	12:00
	5	5.3	12:00
	10	5.6	12:00
	15	5.7	12:00
	20	5.9	12:00
	25	5.7	12:00
	30	4.7	12:00
	CL	5.3	12:00
Left	5	5.8	11:00
	10	5.5	11:00
	15	4.4	11:00
	20	2.7	11:00
Sta 113+50			
Right	TOE	6.2	12:00
	5	6.2	12:00
	10	5.9	12:00
	15	5.9	12:00
	20	5.8	12:00
	CL	5.6	12:00
Left	5	5.9	12:00
	10	5.6	12:00
	15	5.1	12:00
	20	5.3	12:00

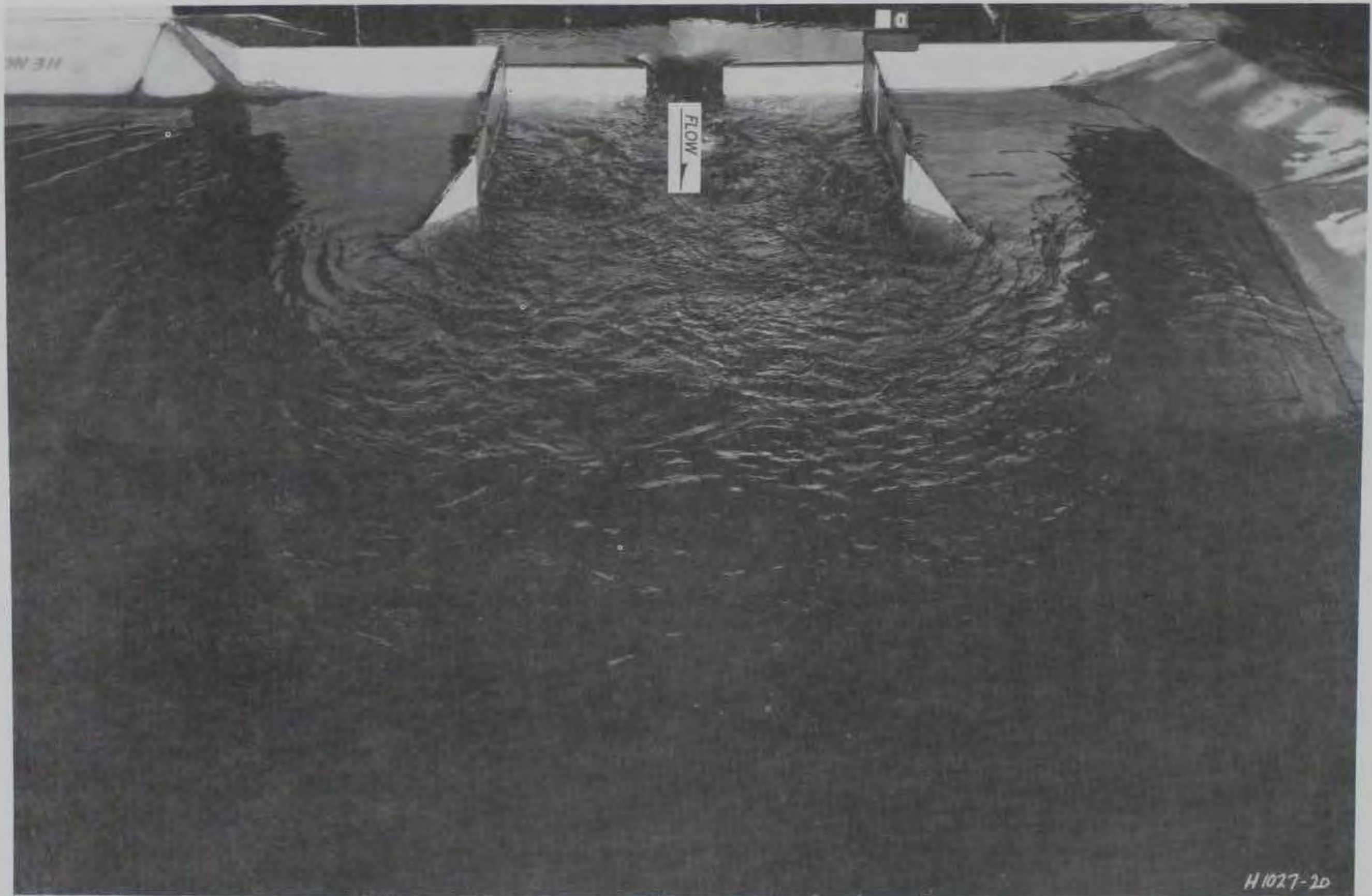

Photo 1. Type 23 weir, discharge 991 cu m/sec (35,000 cfs), tailwater el 759.71

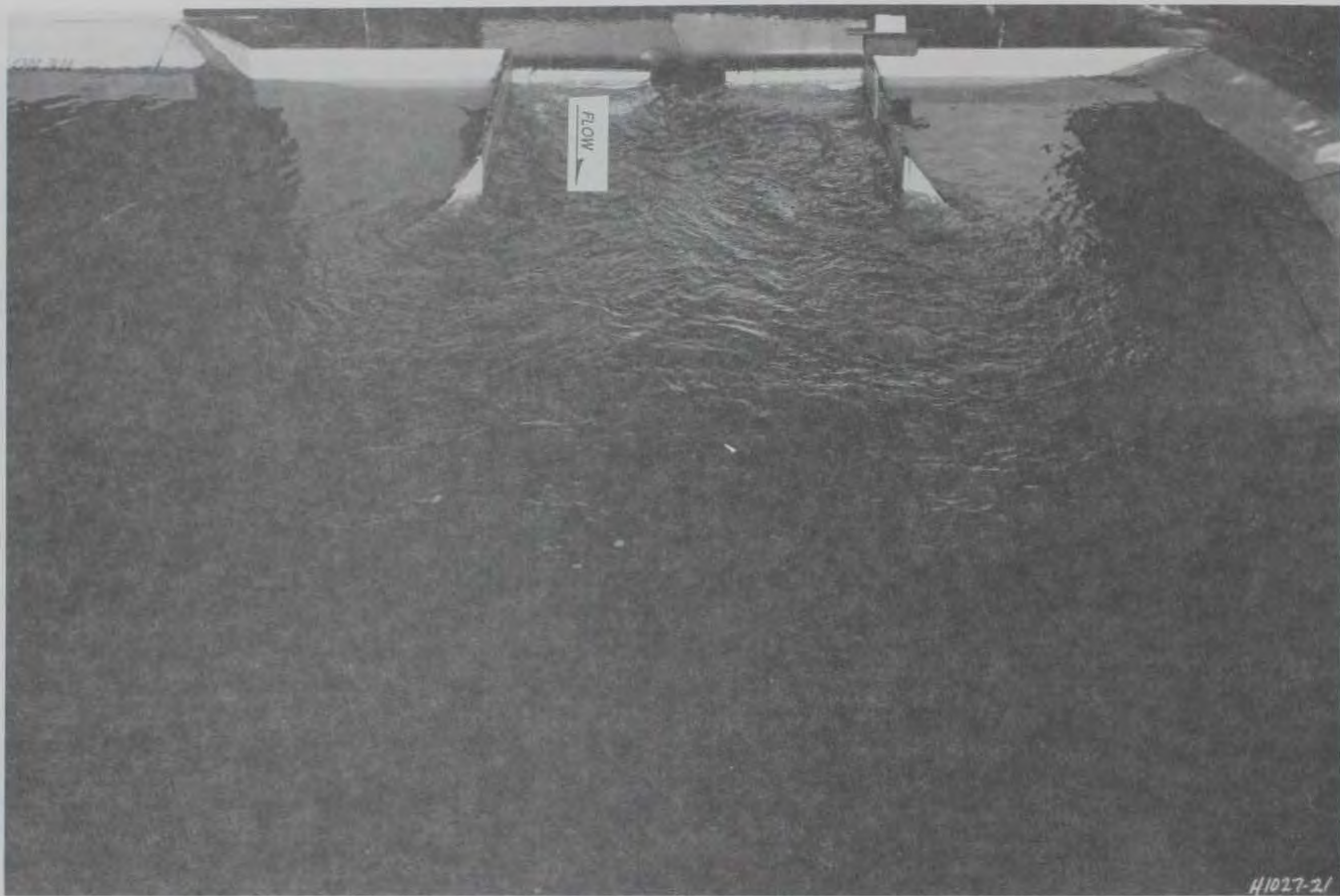

Photo 2. Type 23 weir, discharge 1,557 cu m/sec (55,000 cfs), tailwater el 766.71

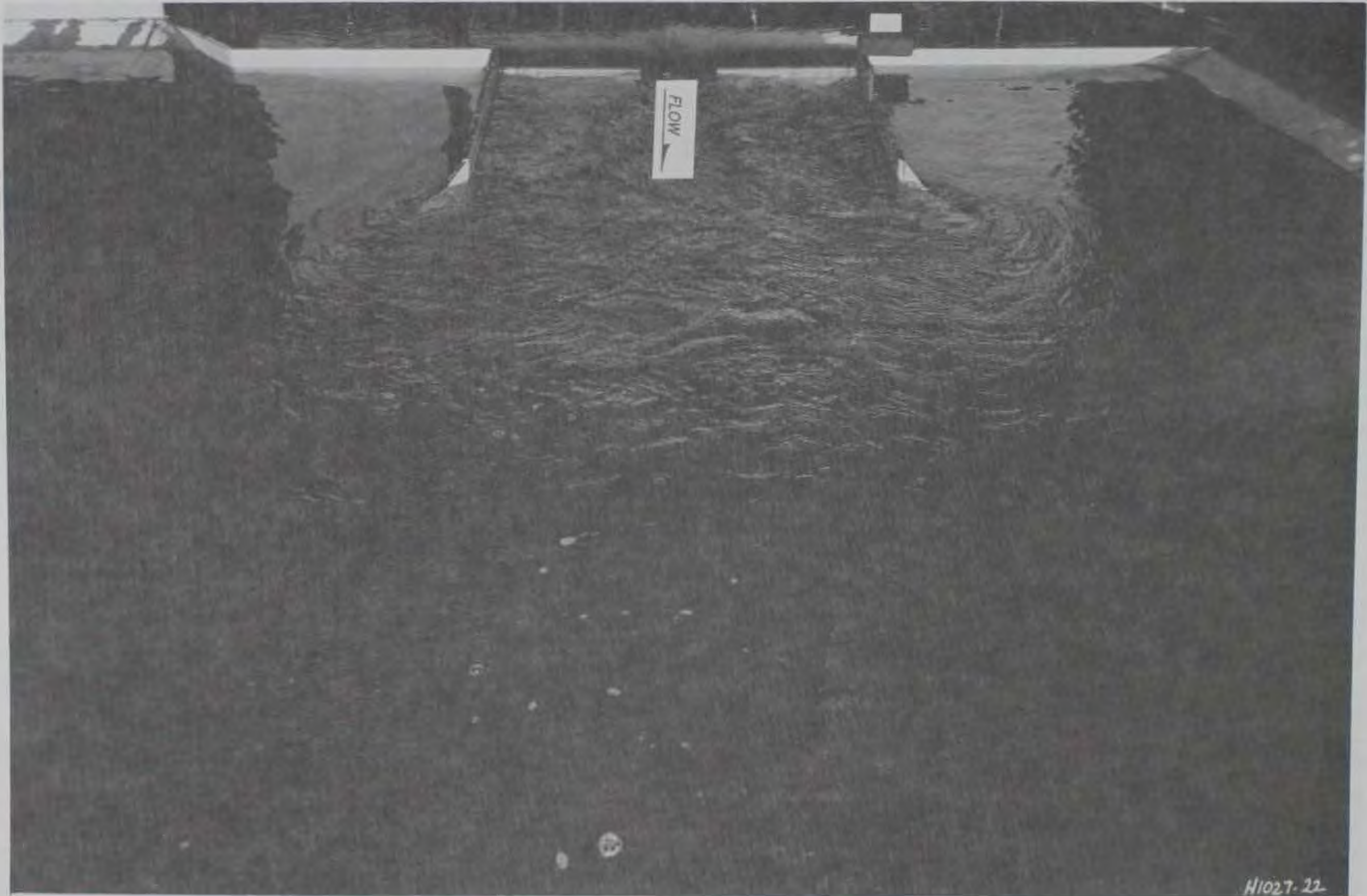

Photo 3. Type 23 weir, discharge 2,265 cu m/sec (80,000 cfs), tailwater el 772.28

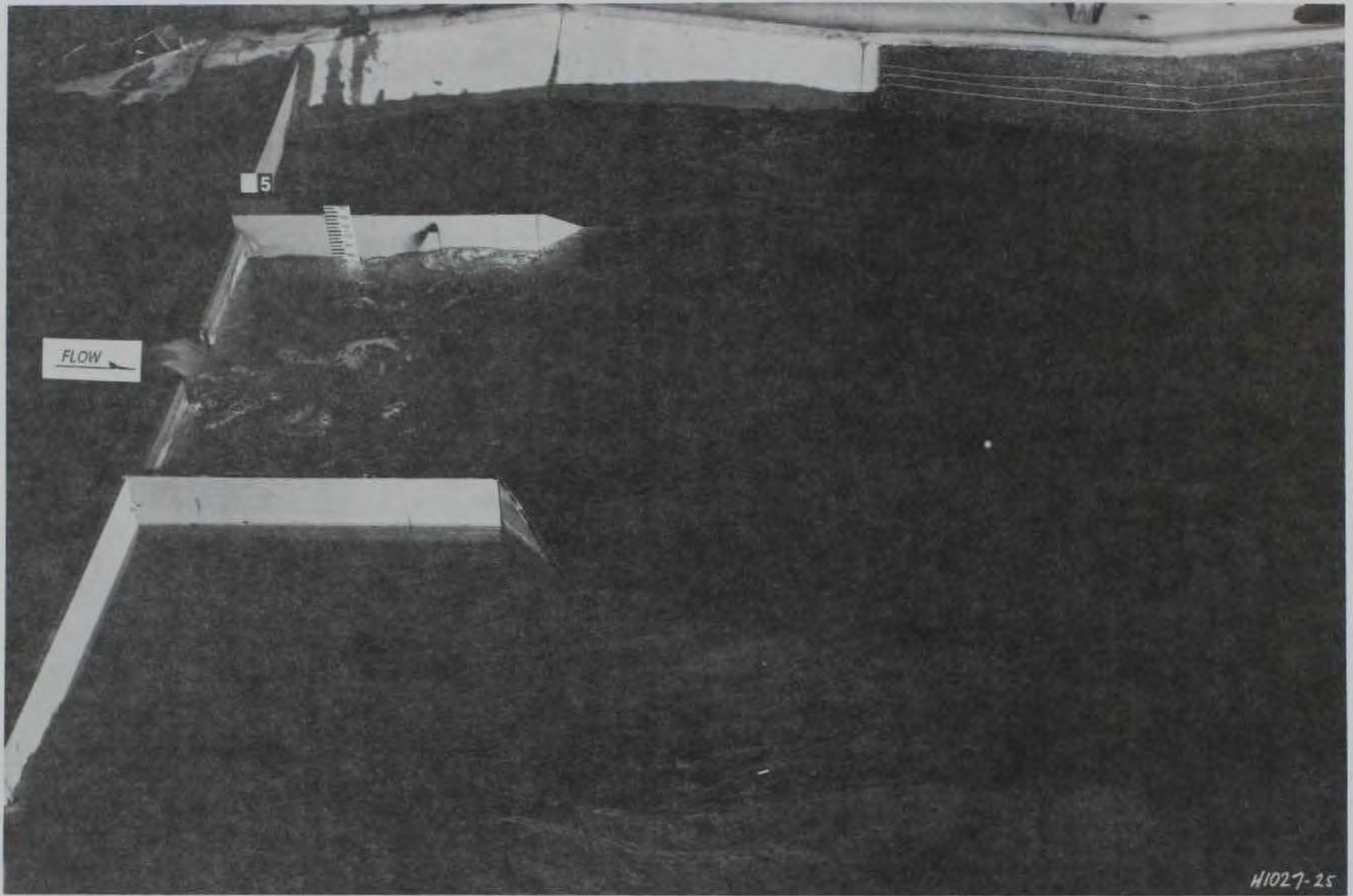

Photo 4. Type 23 weir, basin flow, discharge 991 cu m/sec (35,000 cfs), tailwater el 759.71

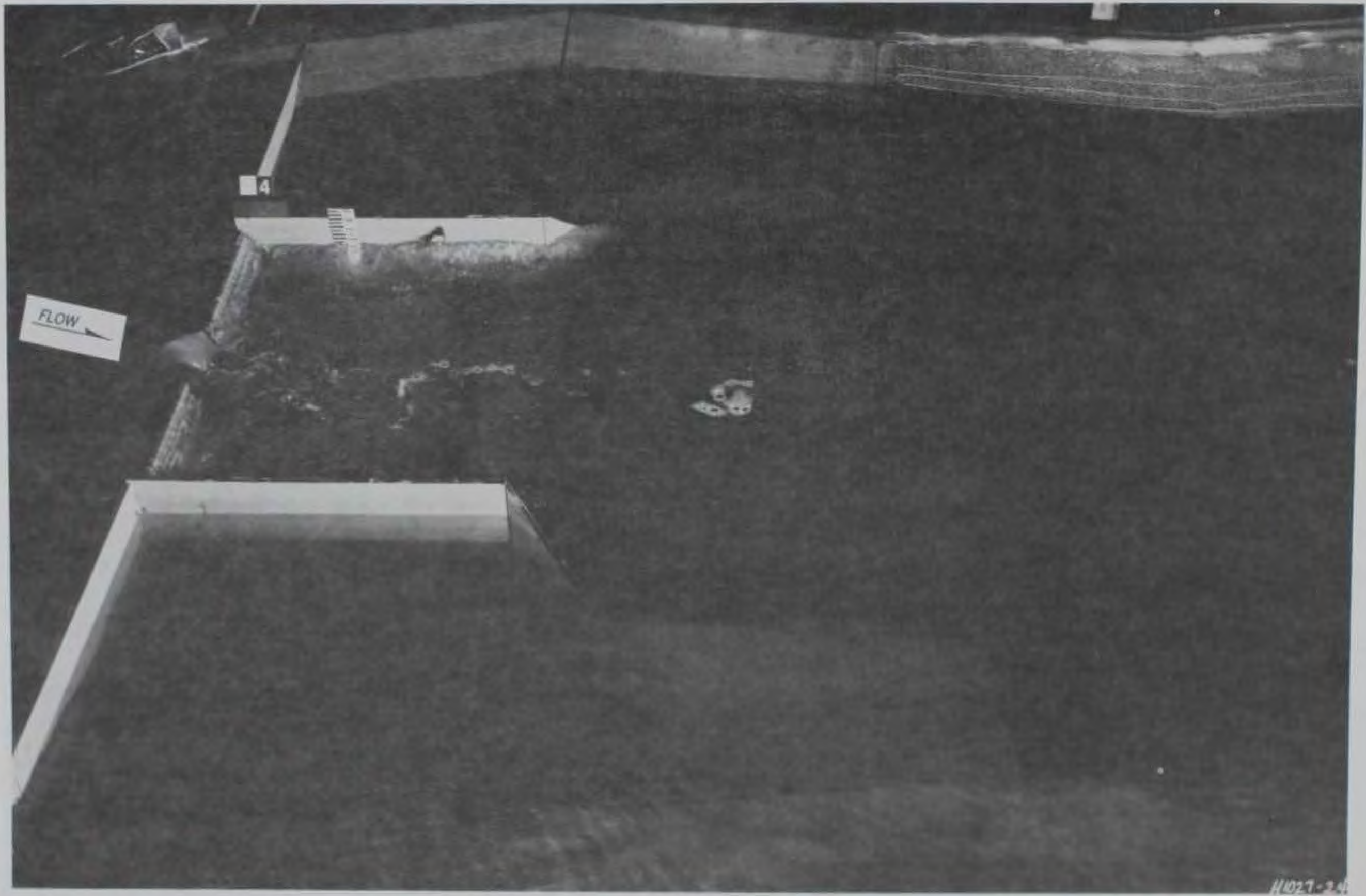

Photo 5. Type 23 weir, basin flow, discharge 1,557 cu m/sec (55,000 cfs), tailwater el 766.71

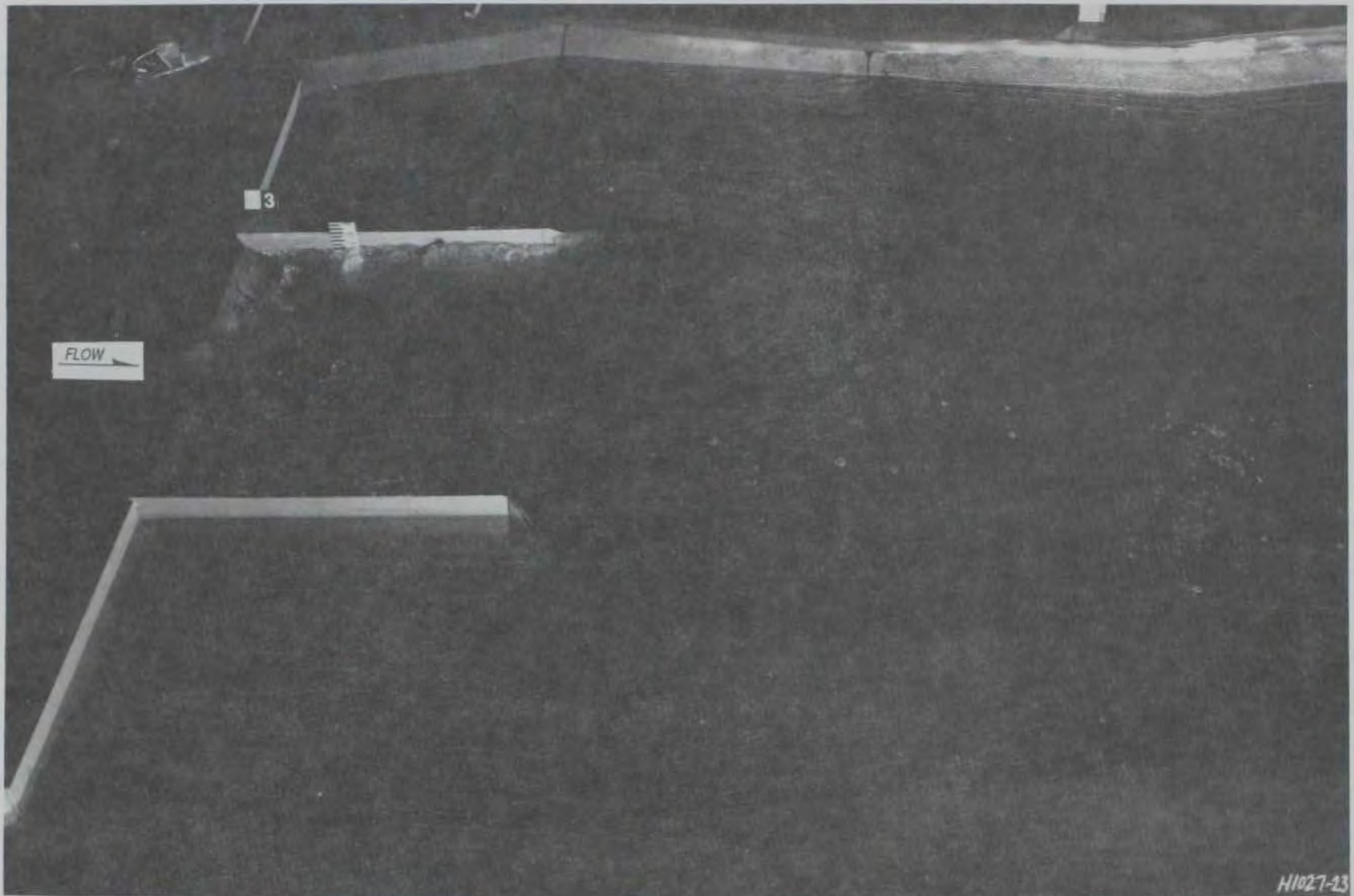

Photo 6. Type 23 weir, basin flow, discharge 2,265 cu m/sec (80,000 cfs), tailwater el 772.28

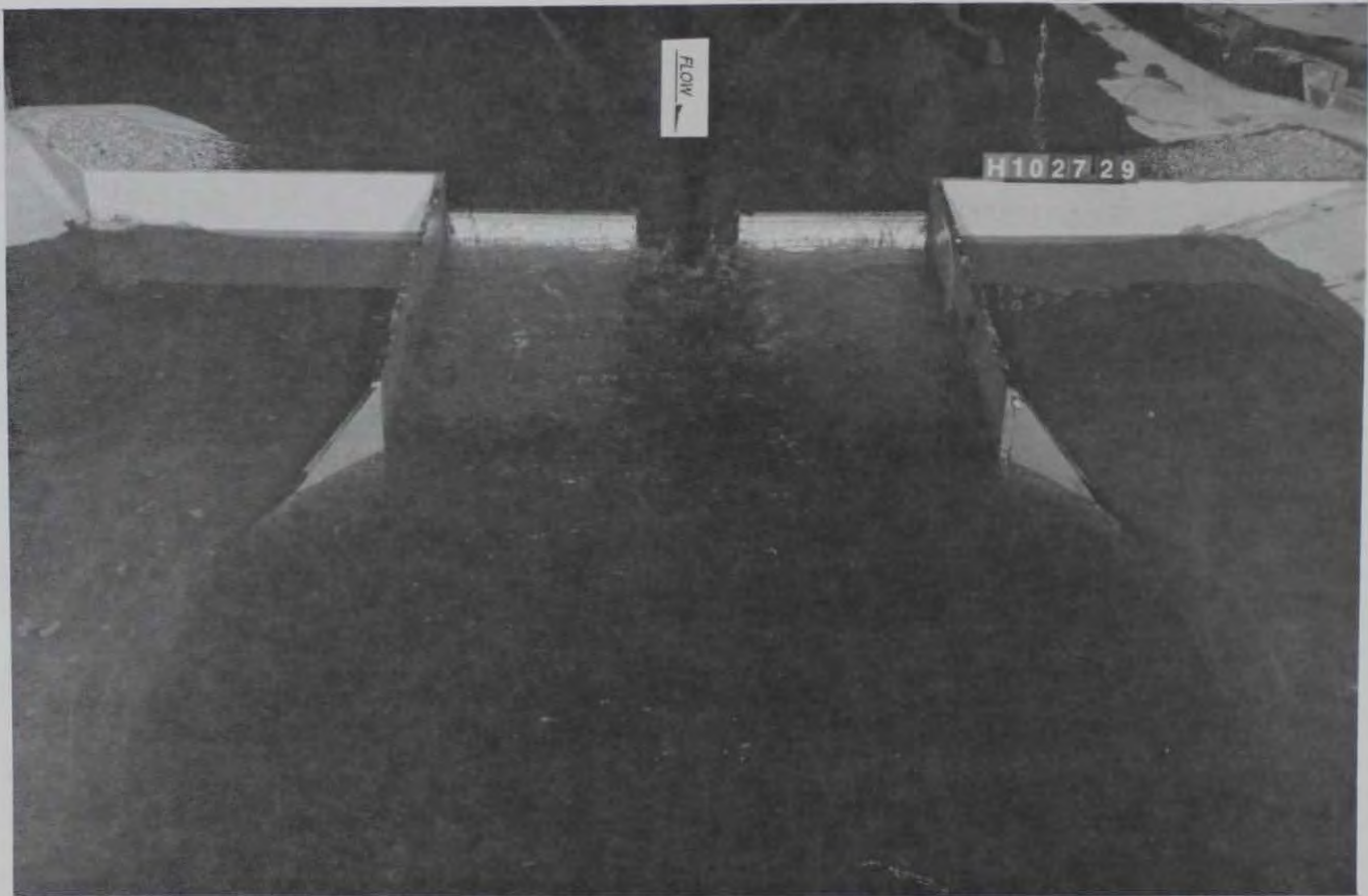

Photo 7. Type 25 weir, weir flow, discharge 991 cu m/sec (35,000 cfs), tailwater el 759.71

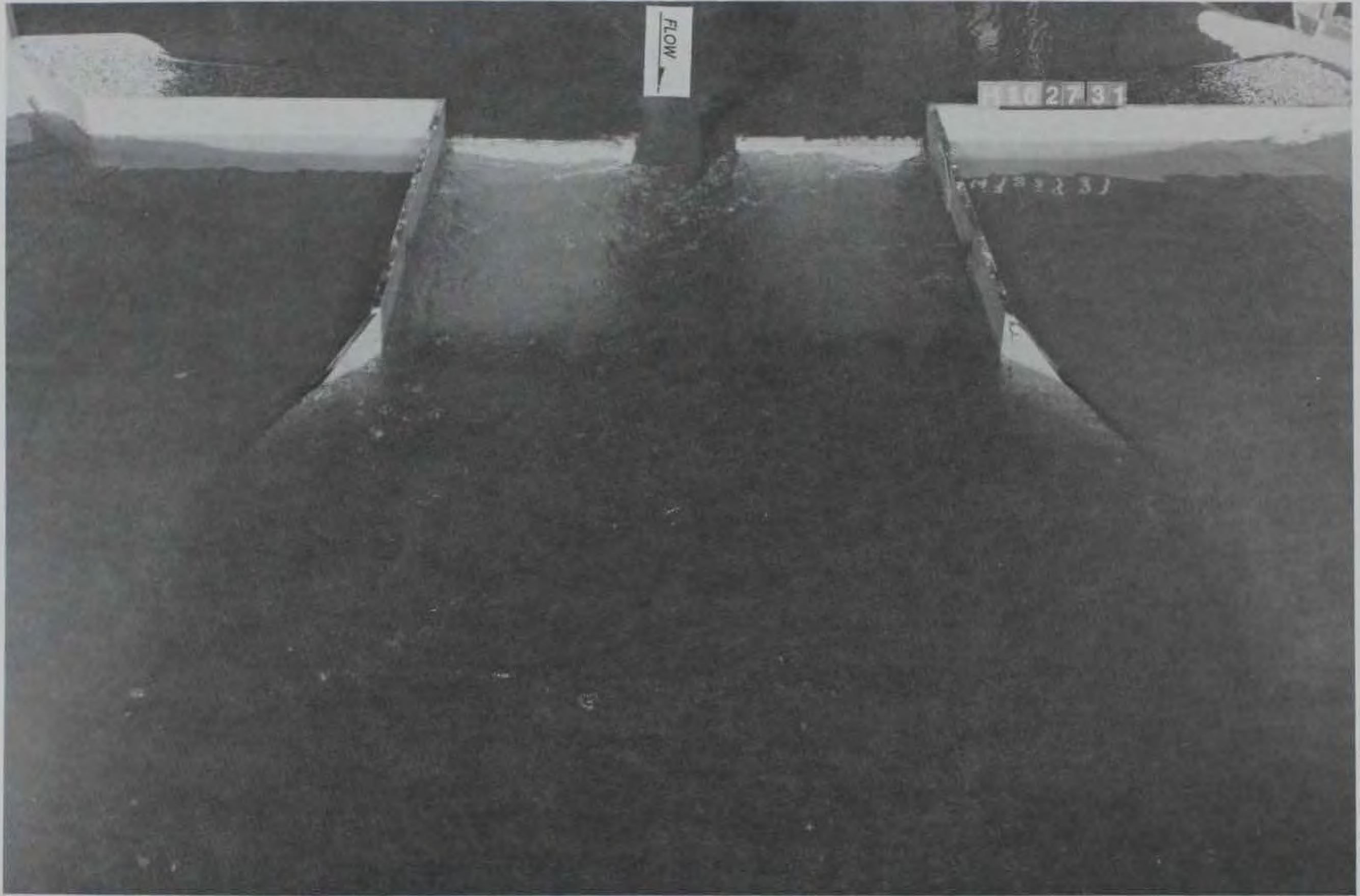

Photo 8. Type 25 weir, weir flow, discharge 991 cu m/sec (55,000 cfs), tailwater el 766.71

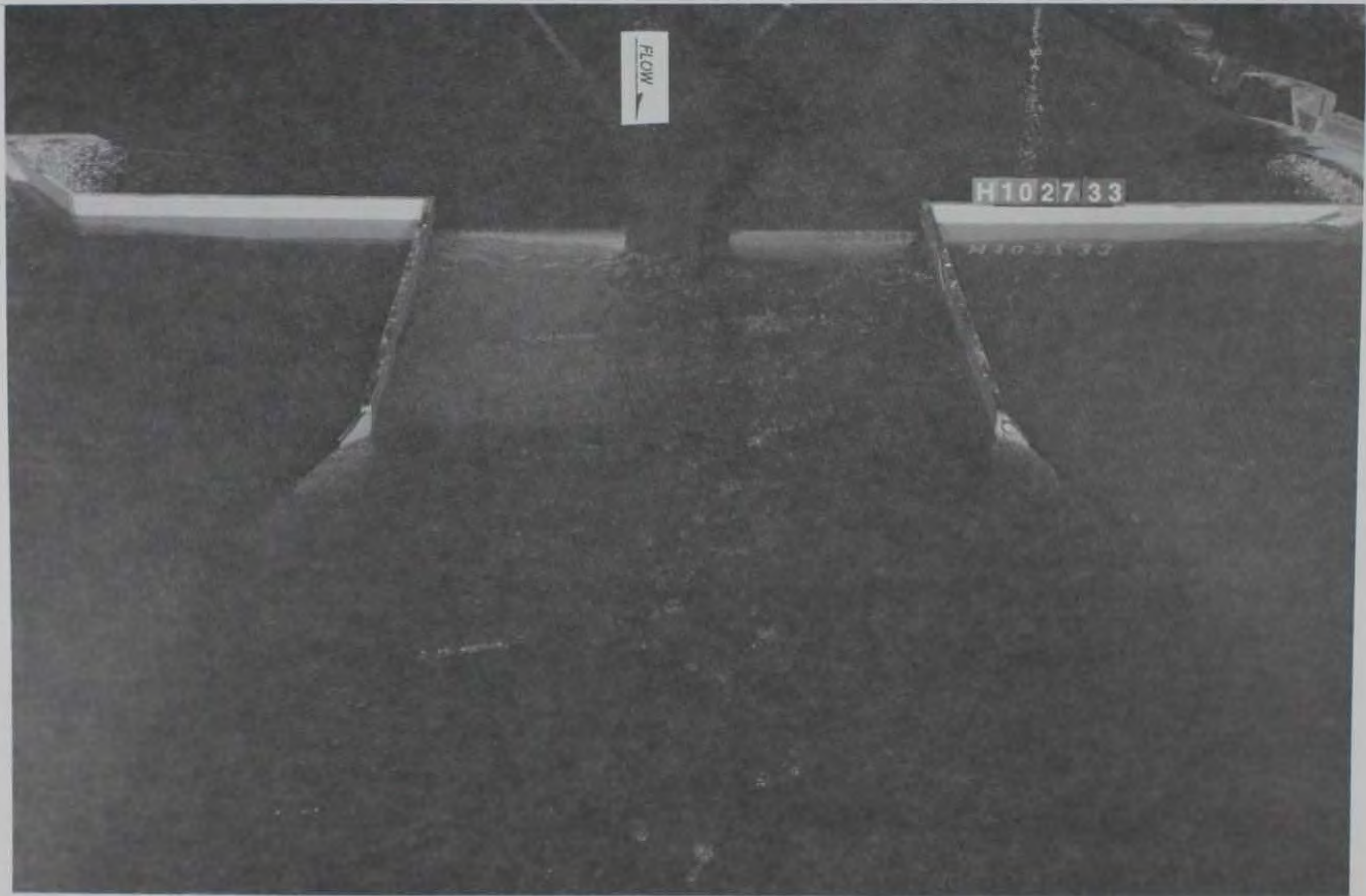

Photo 9. Type 25 weir, weir flow, discharge 2,265 cu m/sec (80,000 cfs), tailwater el 772.28



Photo 10. Type 2 debris deflectors, debris passage looking upstream, discharge 28 cu m/sec (1,000 cfs), tailwater el 735.54

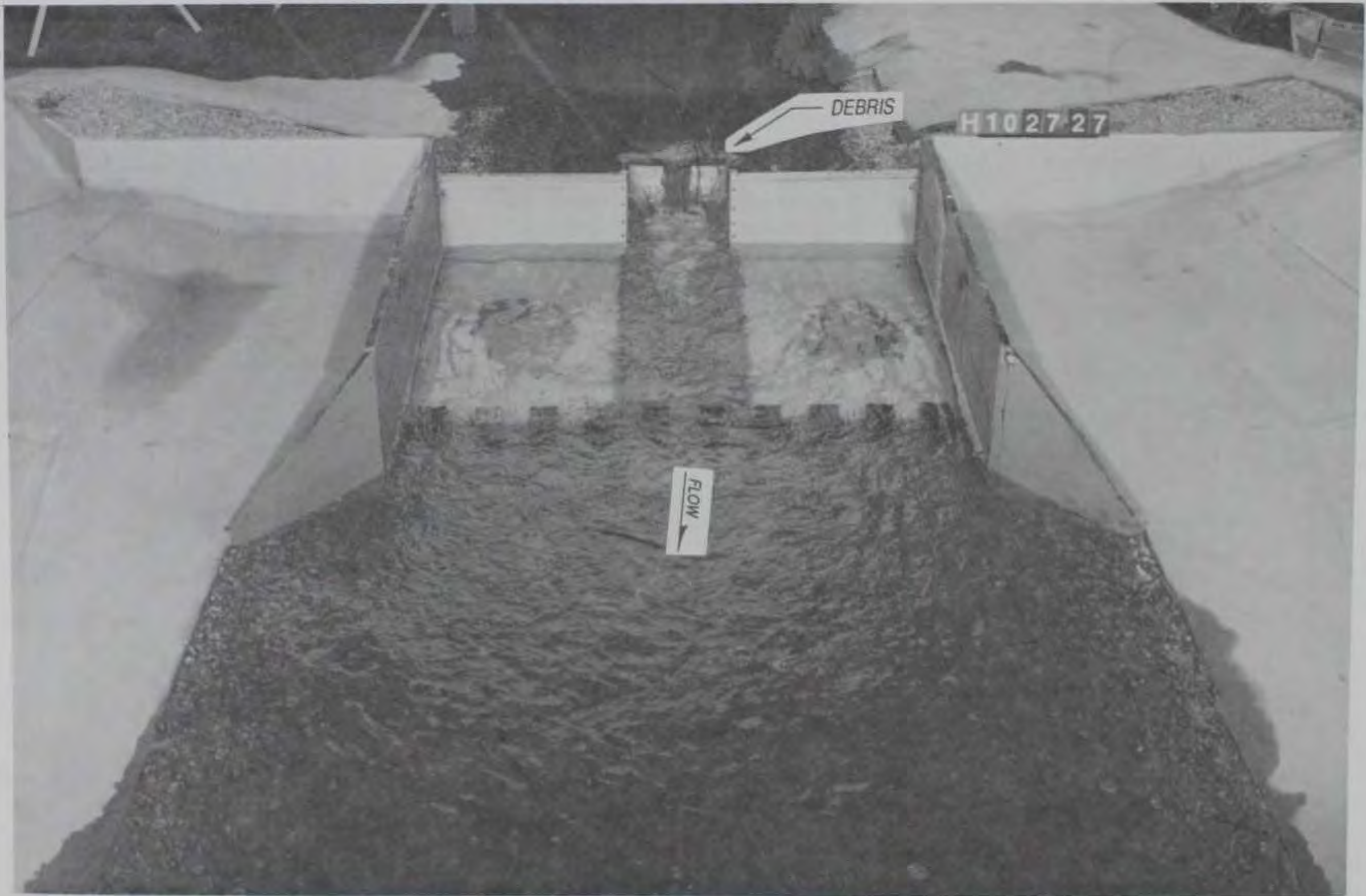

Photo 11. Type 2 debris deflectors, debris passage looking upstream, discharge 142 cu m/sec (5,000 cfs), tailwater el 741.44

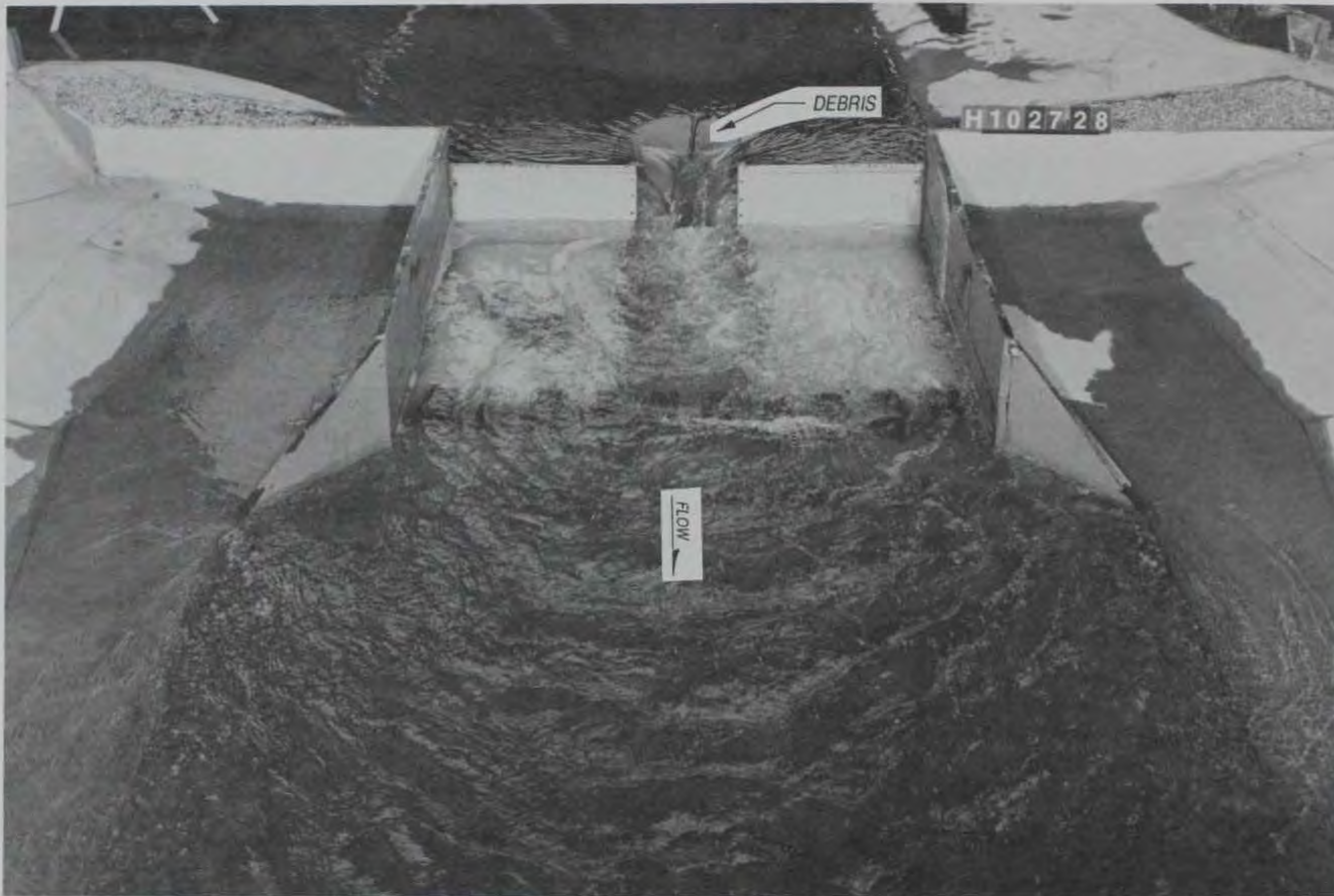

Photo 12. Type 2 debris deflectors, debris passage looking upstream, discharge 283 cu m/sec (10,000 cfs), tailwater el 747.01



Photo 13. Type 2 debris deflectors, debris passage looking downstream, discharge 28 cu m/sec (1,000 cfs), tailwater el 735.54



Photo 14. Type 2 debris deflectors, debris passage looking downstream, discharge 142 cu m/sec (5,000 cfs), tailwater el 741.44



Photo 15. Type 2 debris deflectors, debris passage looking downstream, discharge 283 cu m/sec (10,000 cfs), tailwater el 747.01

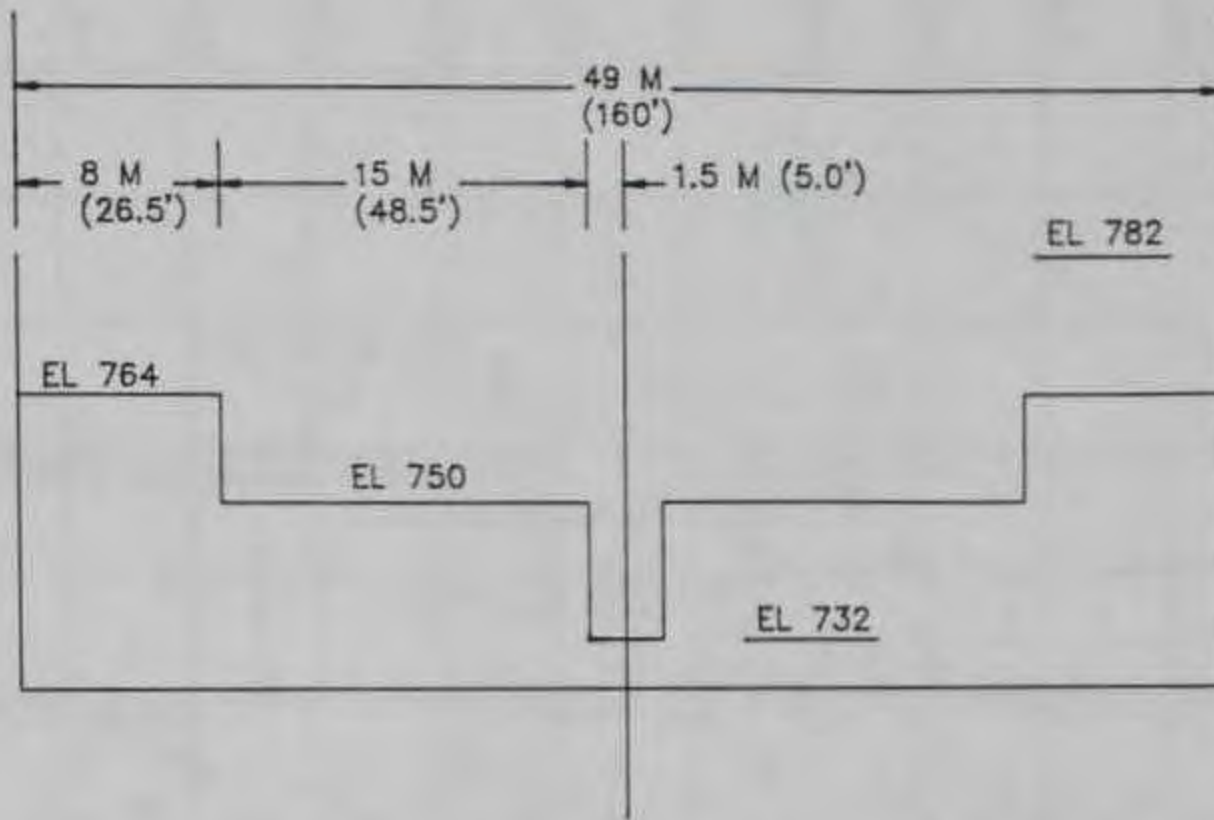

ELEVATION

TYPE 1 (ORIGINAL) DESIGN

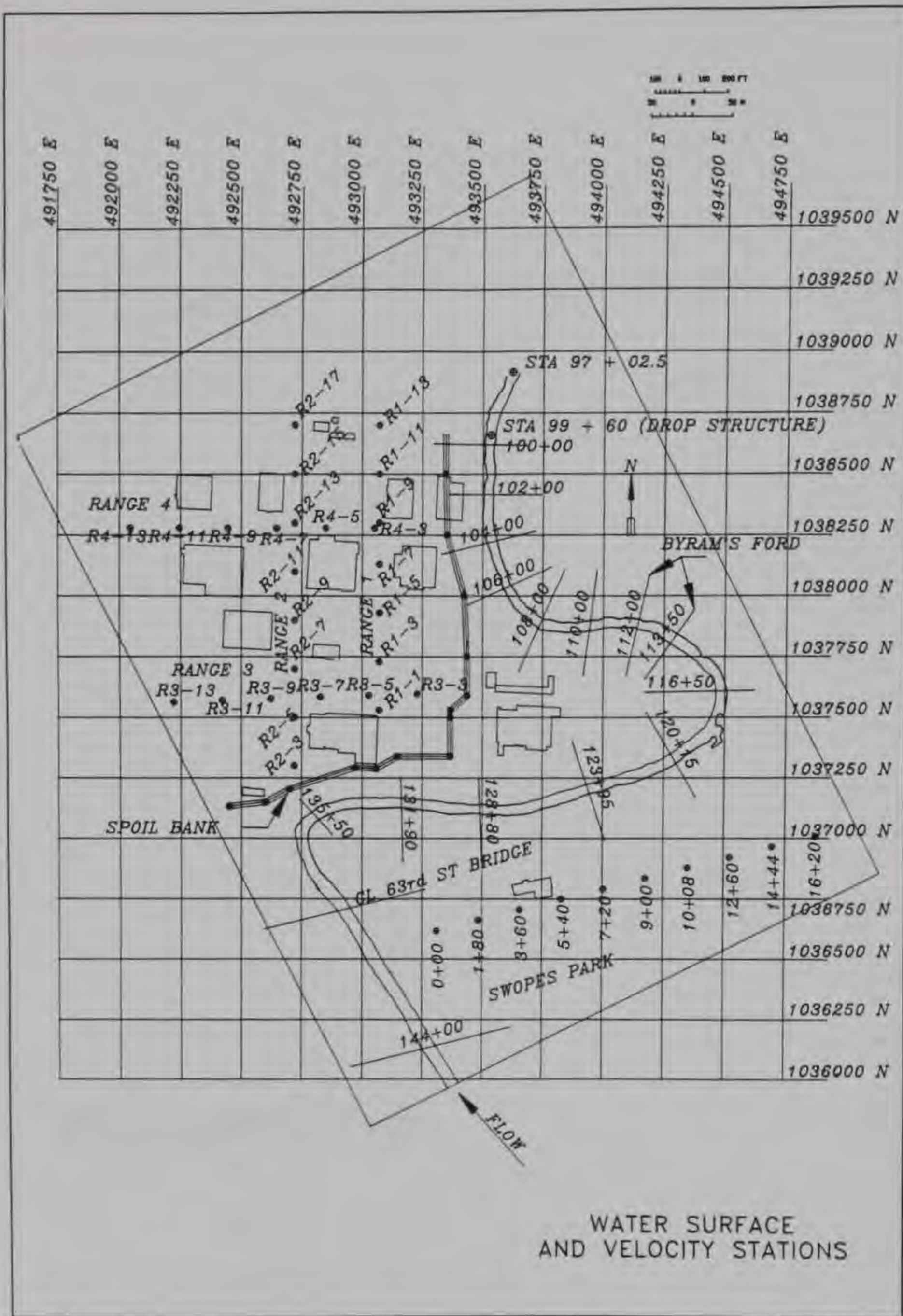
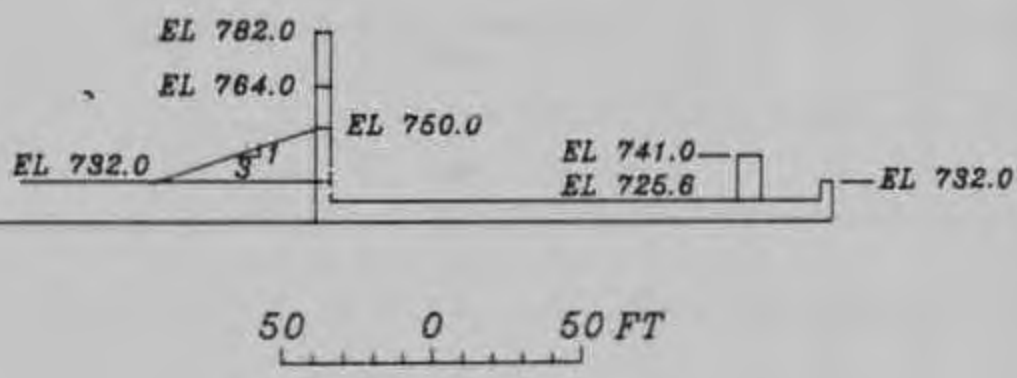
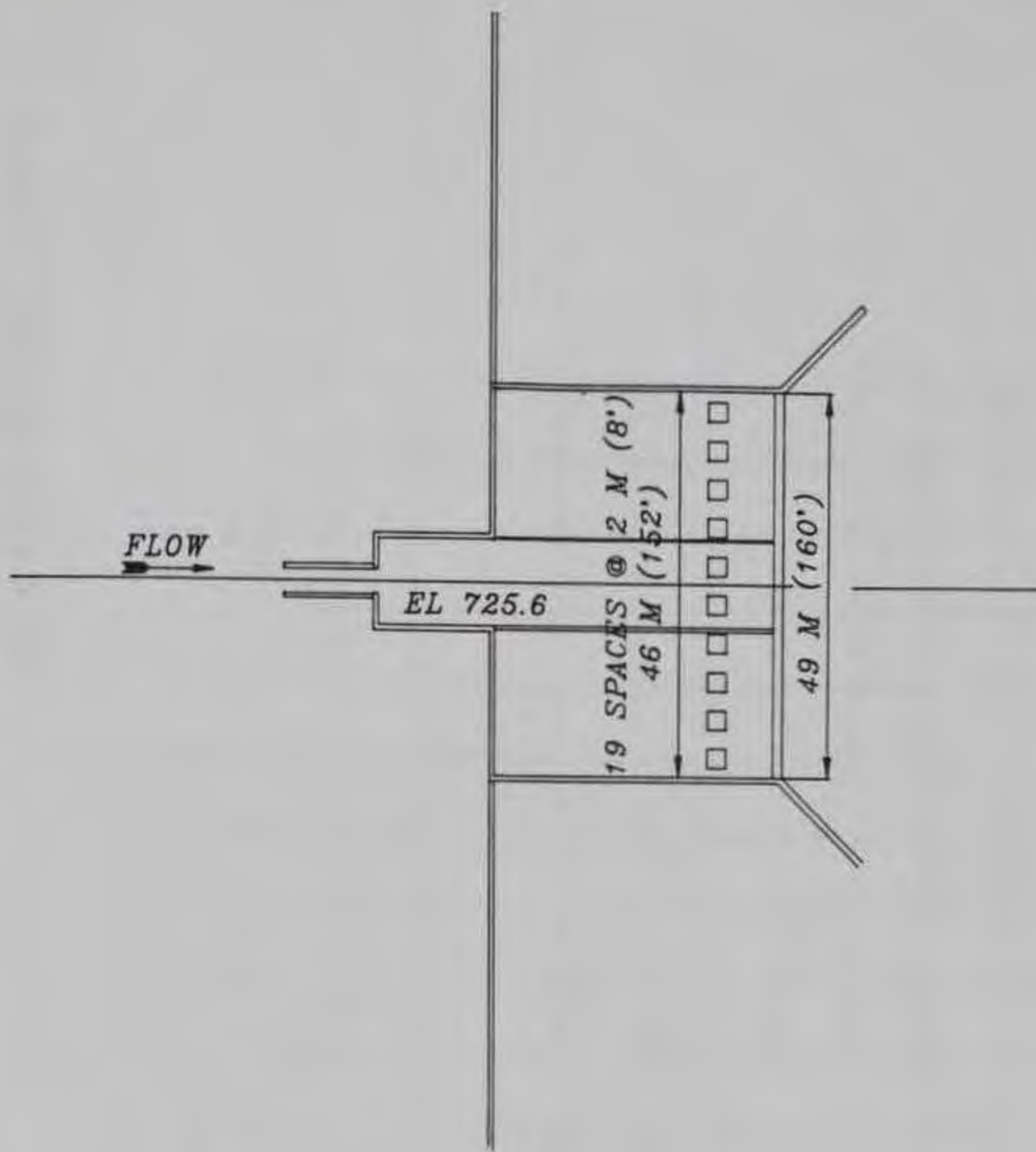
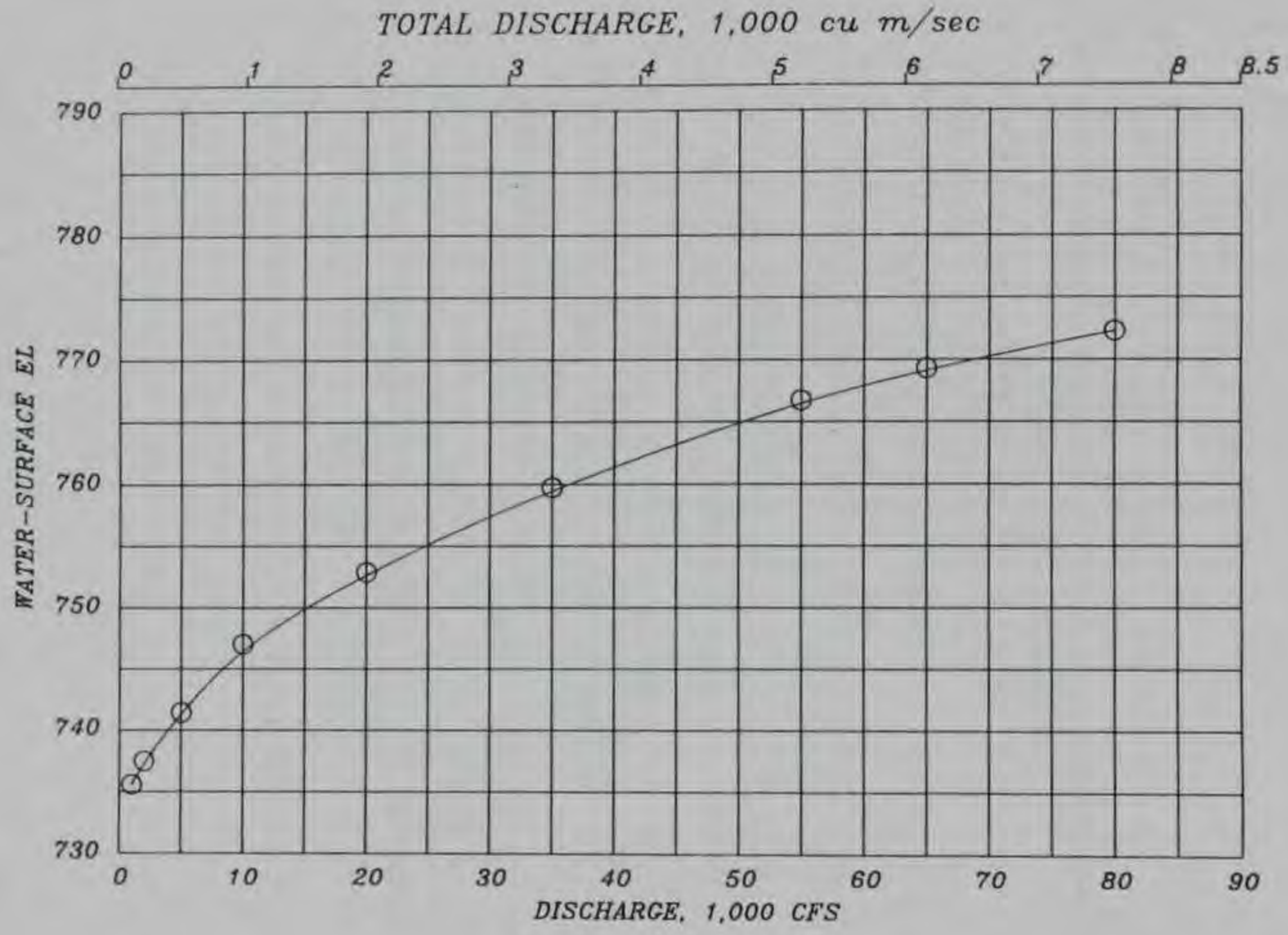

Plate 2



TYPE 1 (ORIGINAL)
STILLING BASIN



TAILWATER RATING CURVE
STA 97+02.5

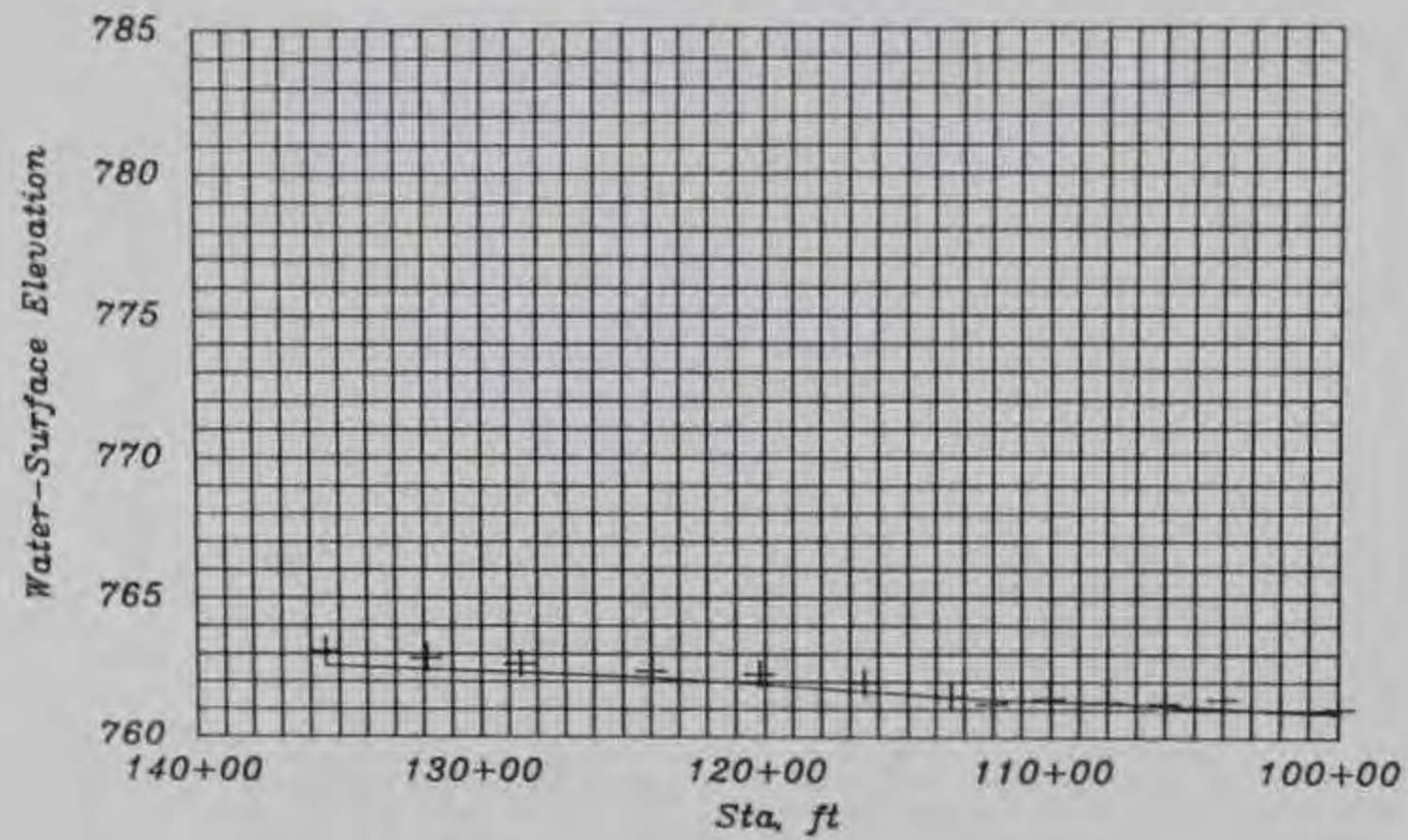

LEGEND
 - Baseline
 + Measured

WATER-SURFACE PROFILE
 EXISTING CONDITIONS
 283 CU M/SEC (10,000 CFS)

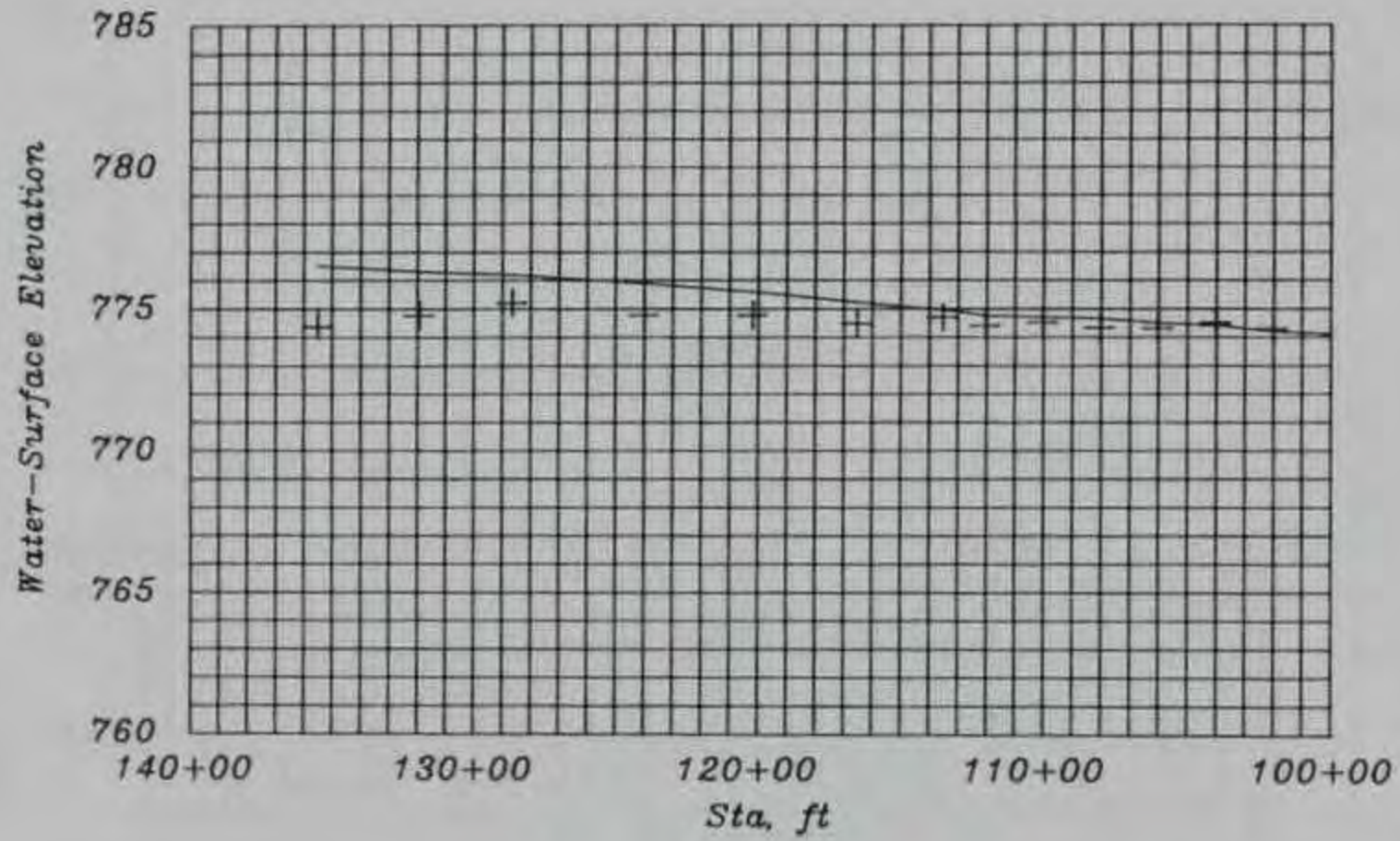

LEGEND
- Baseline
+ Measured

WATER-SURFACE PROFILE
EXISTING CONDITIONS
849 CU M/SEC (30,000 CFS)

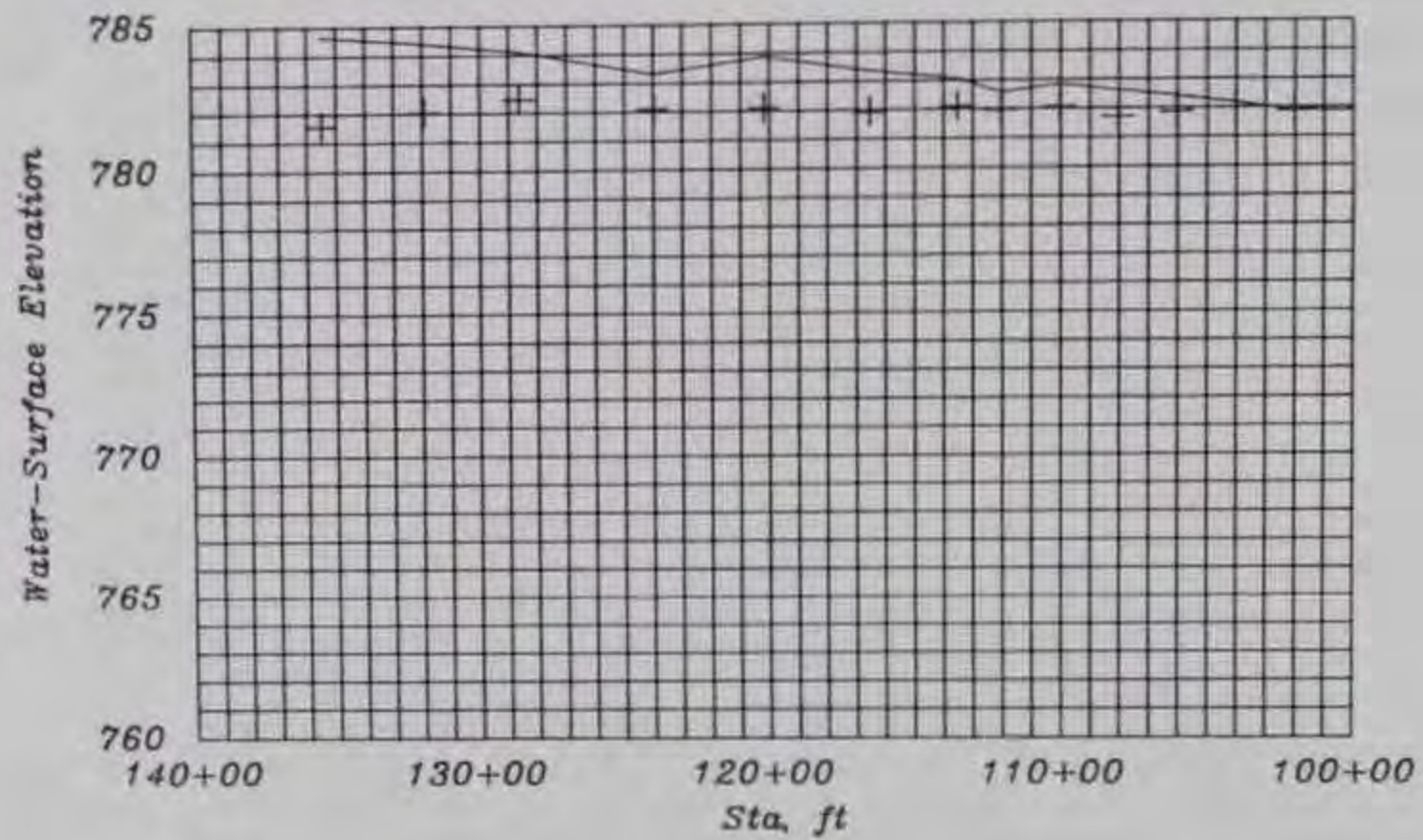

LEGEND
 - Baseline
 + Measured

WATER-SURFACE PROFILE
 EXISTING CONDITIONS
 2,265 CU M/SEC (80,000 CFS)

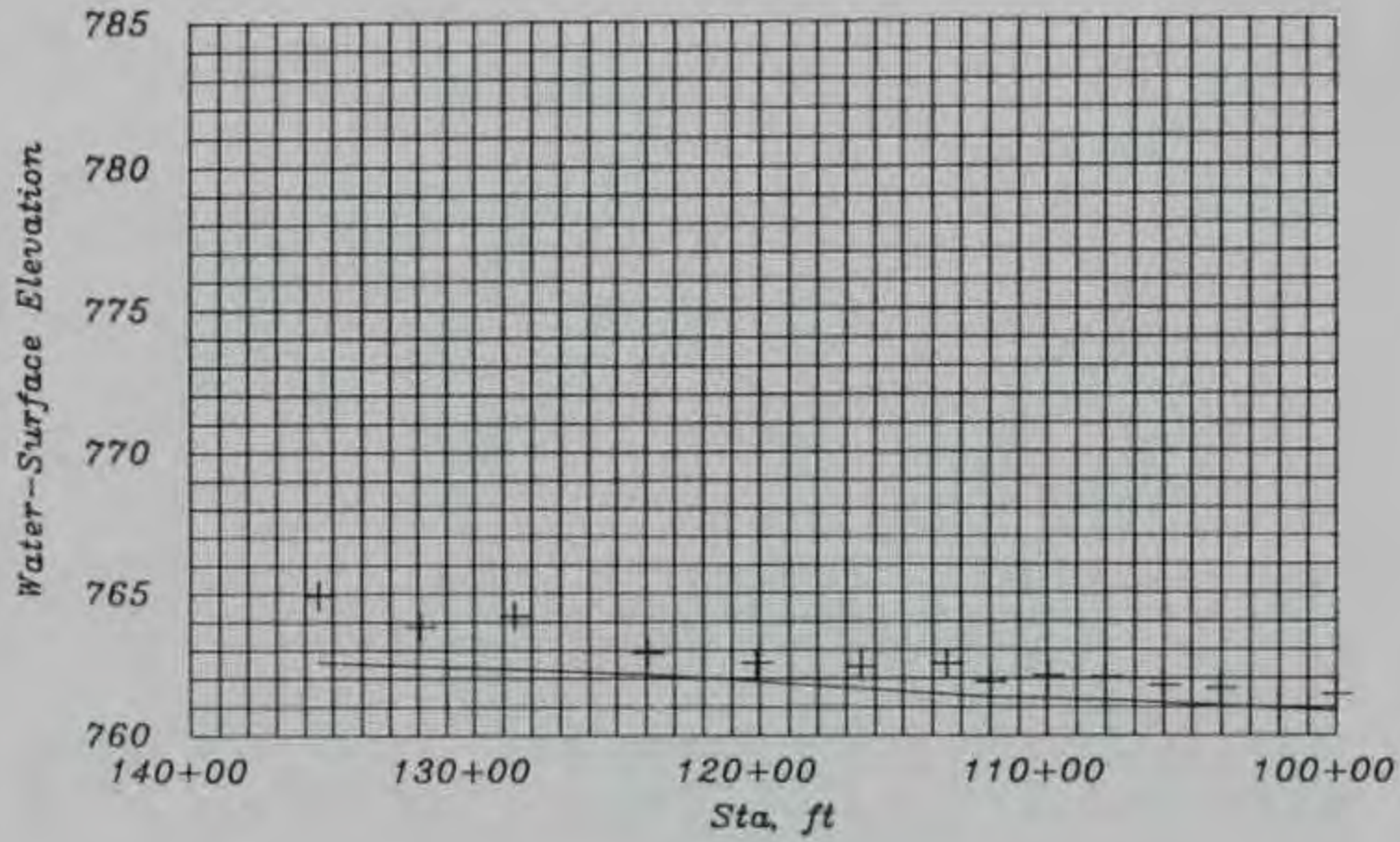

LEGEND
- Baseline
+ Measured

WATER-SURFACE PROFILE
EXISTING CONDITIONS WITH ROUGHNESS
283 CU M/SEC (10,000 CFS)

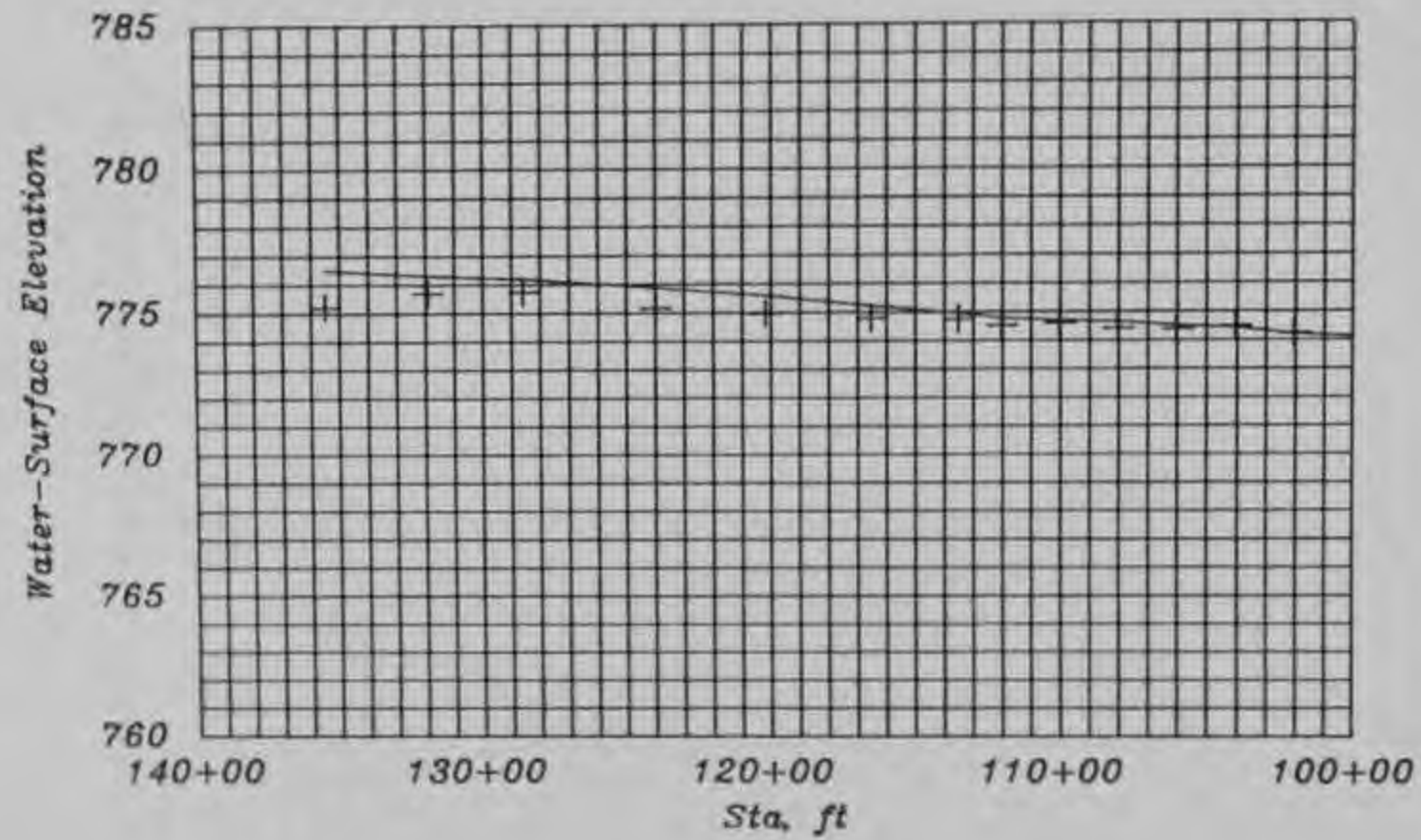

LEGEND
 - Baseline
 + Measured

WATER-SURFACE PROFILE
 EXISTING CONDITIONS WITH ROUGHNESS
 849 CU M/SEC (30,000 CFS)

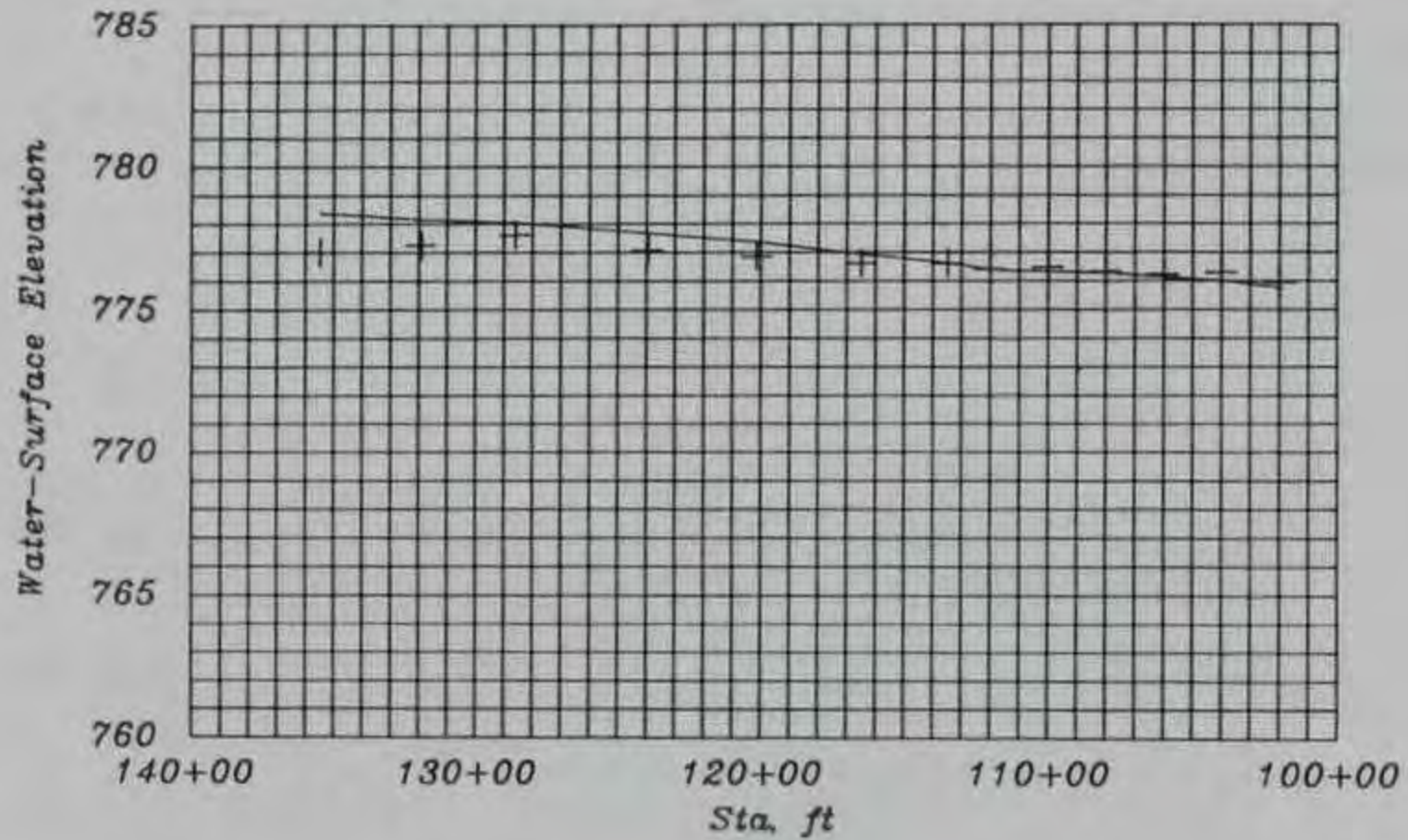

LEGEND
- Baseline
+ Measured

WATER-SURFACE PROFILE
EXISTING CONDITIONS WITH ROUGHNESS
991 CU M/SEC (35,000 CFS)

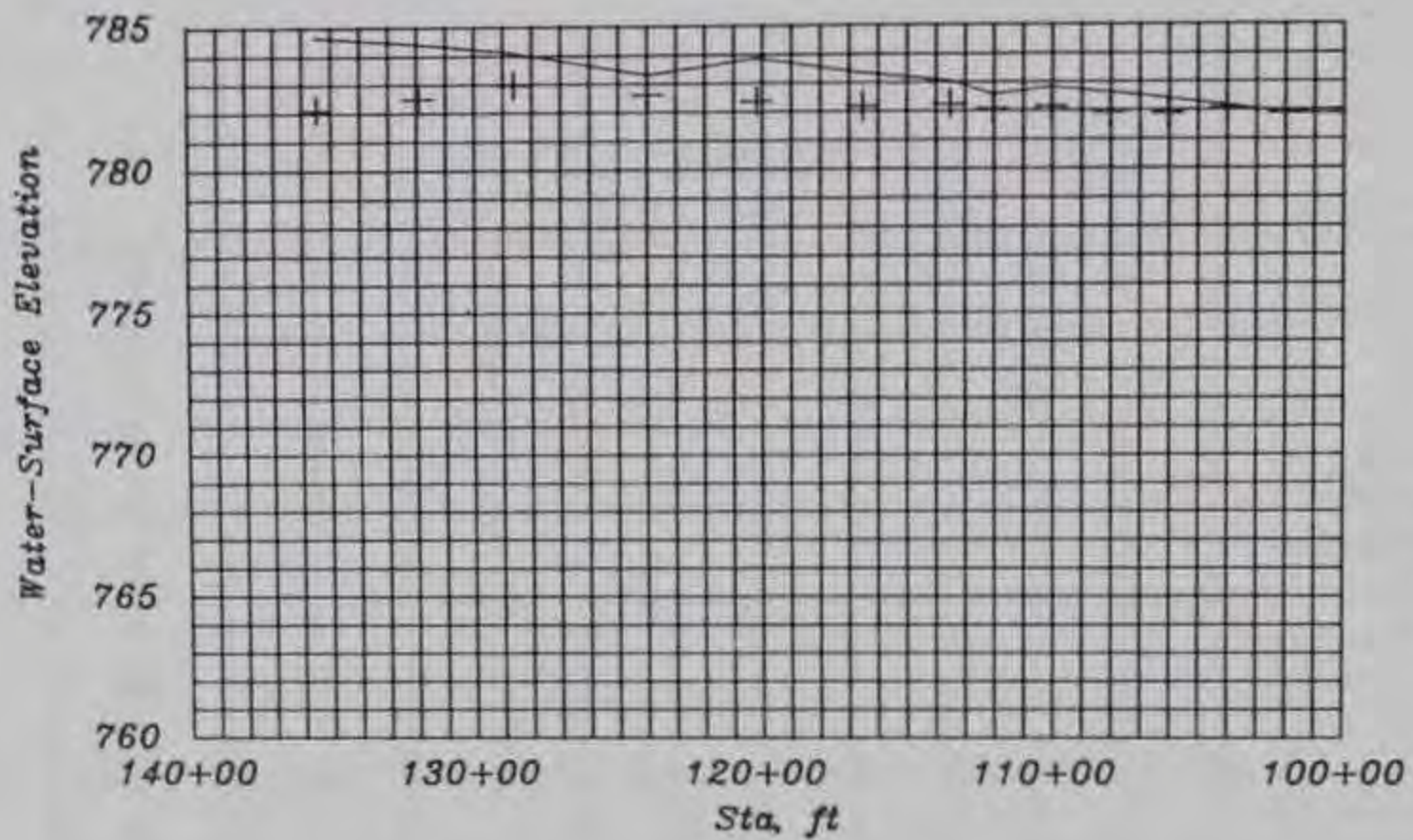

LEGEND
 - Baseline
 + Measured

WATER-SURFACE PROFILE
 EXISTING CONDITIONS WITH ROUGHNESS
 2,265 CU M/SEC (80,000 CFS)

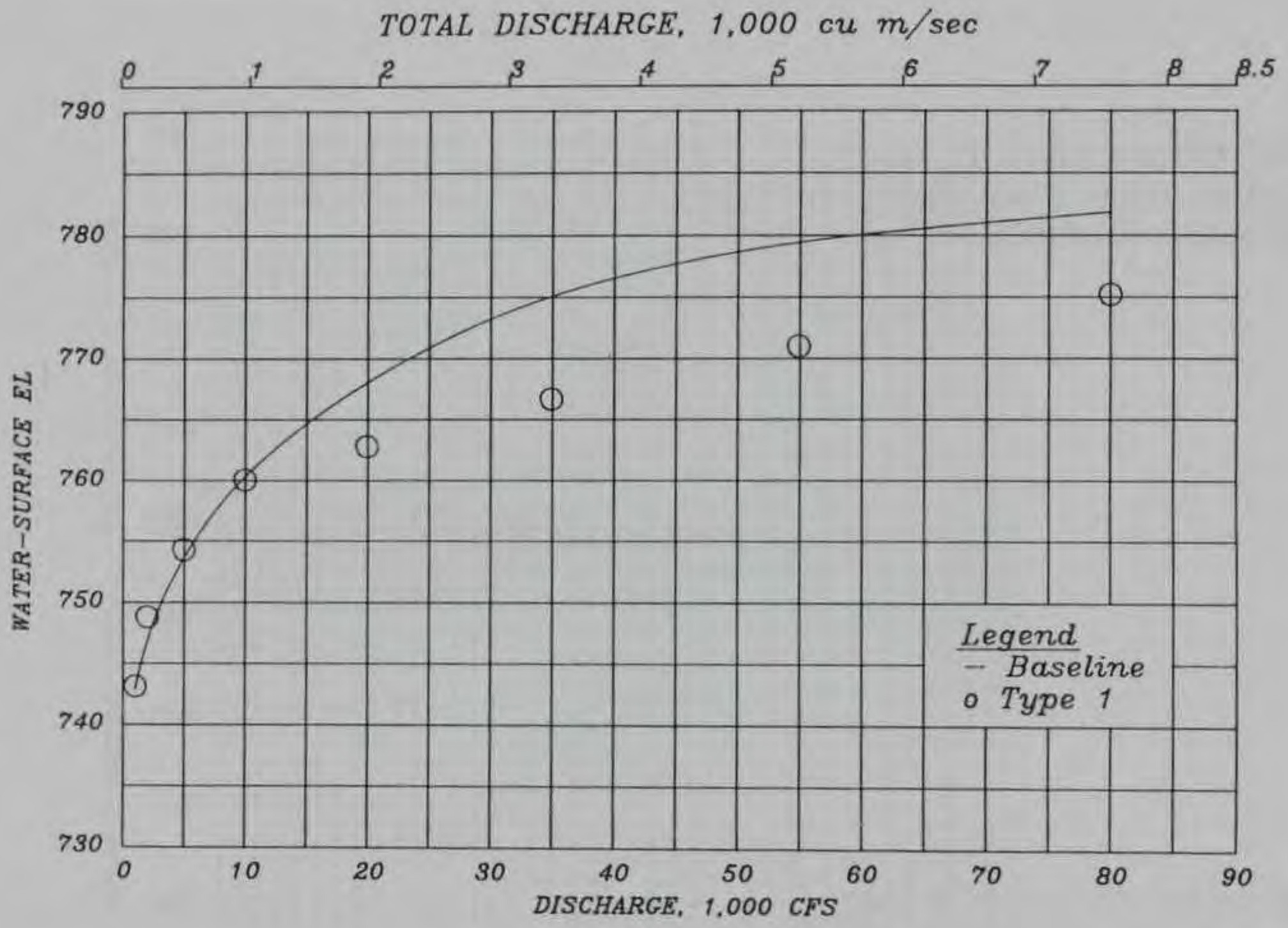

TYPE 1 WEIR
STAGE-DISCHARGE CURVE
STA 102+00

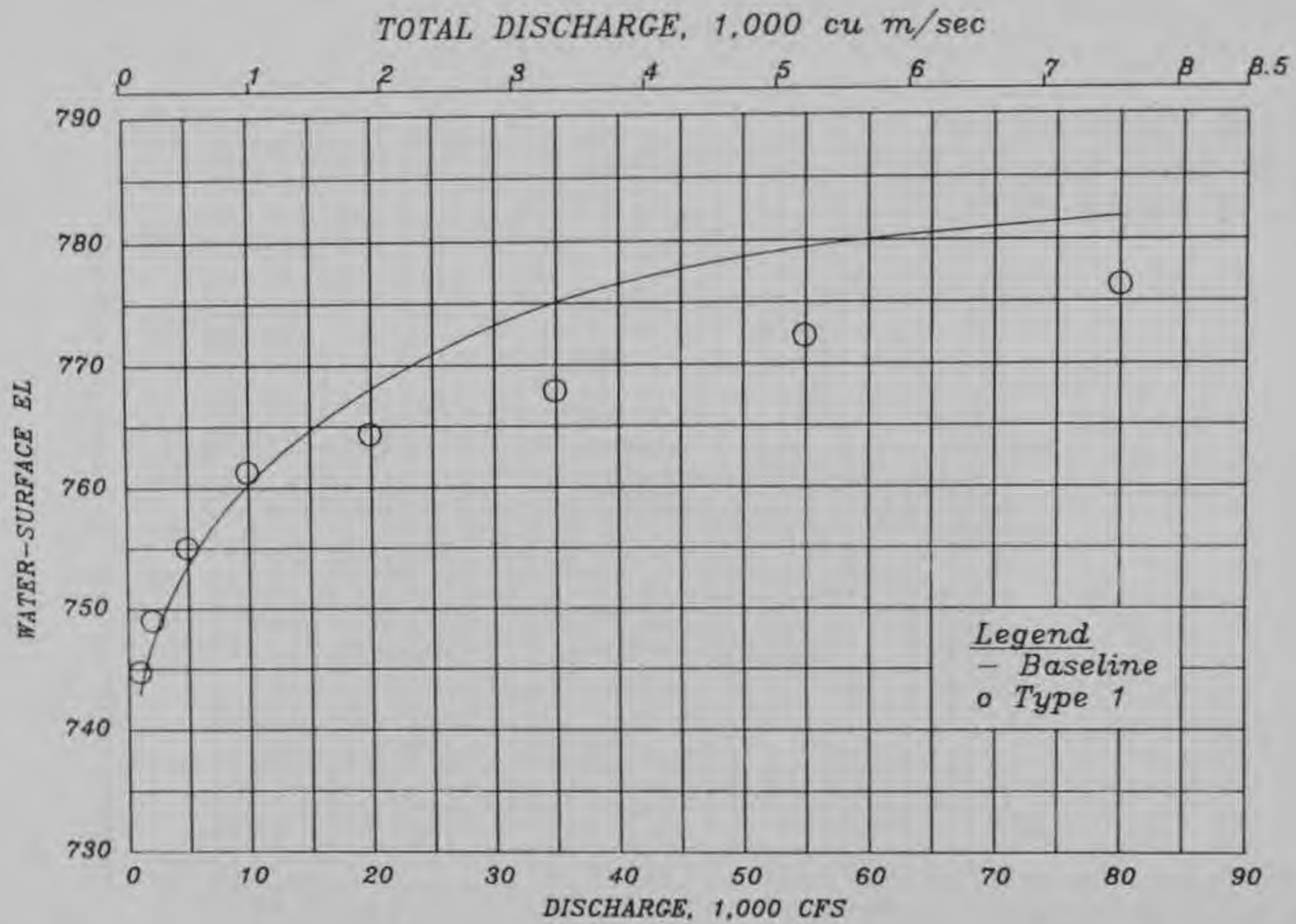

TYPE 1 WEIR
 STAGE-DISCHARGE CURVE
 STA 113+50



LEGEND
- Baseline
+ Measured

WATER-SURFACE PROFILE
TYPE 1 WEIR WITH ROUGHNESS
283 CU M/SEC (10,000 CFS)

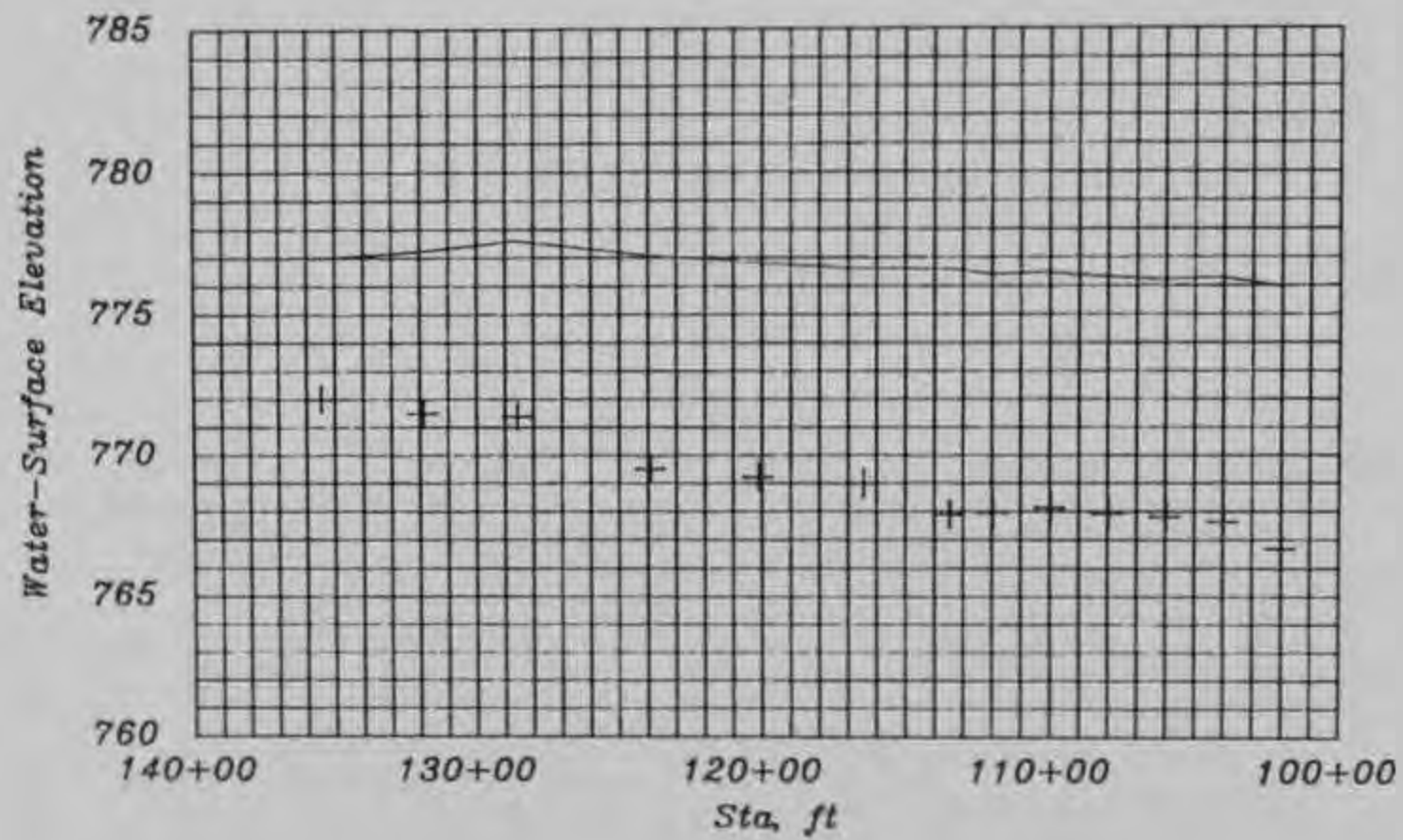

LEGEND
 - Baseline
 + Measured

WATER-SURFACE PROFILE
 TYPE 1 WEIR WITH ROUGHNESS
 991 CU M/SEC (35,000 CFS)

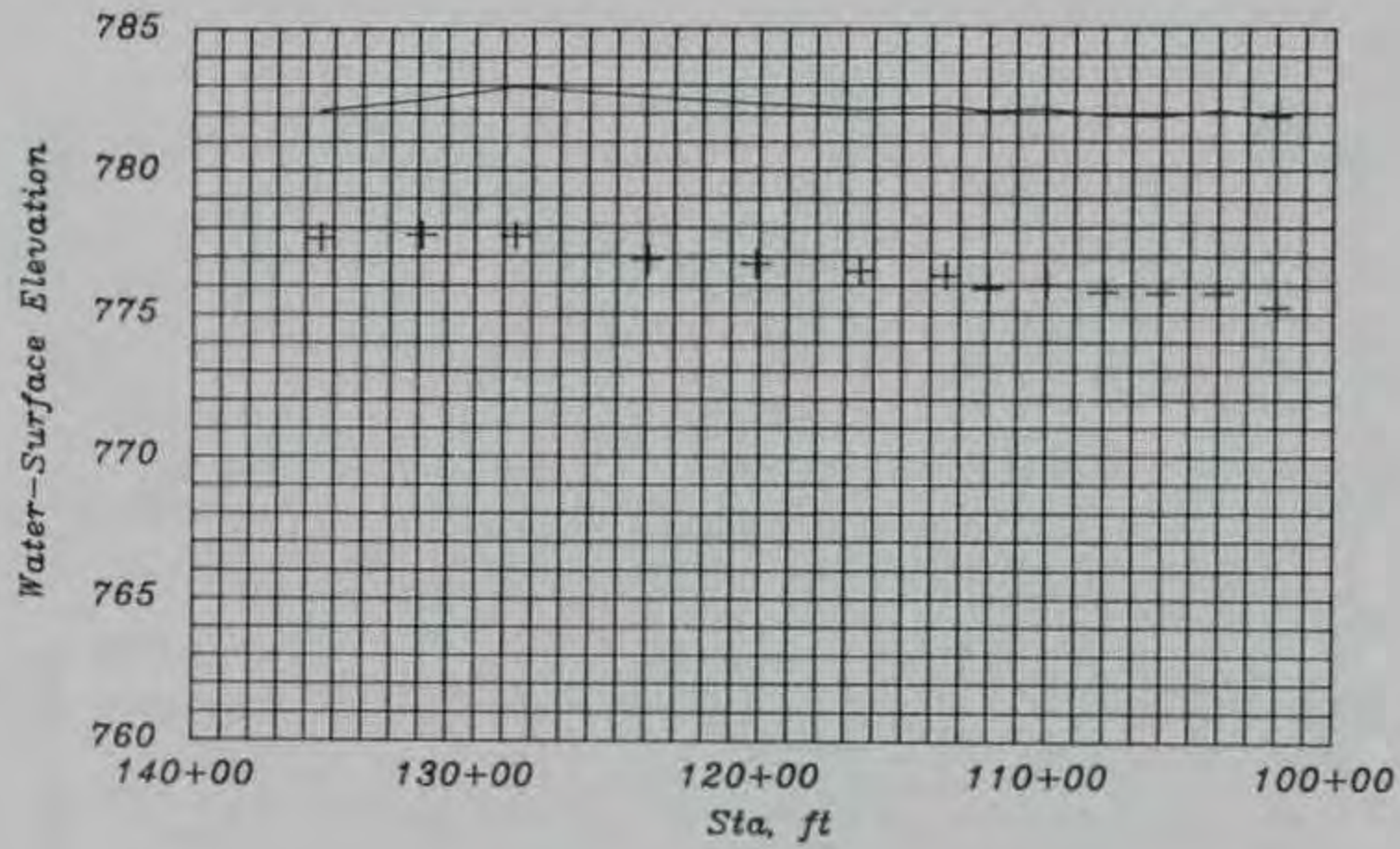

LEGEND
- Baseline
+ Measured

WATER-SURFACE PROFILE
TYPE 1 WEIR WITH ROUGHNESS
2,265 CU M/SEC (80,000 CFS)

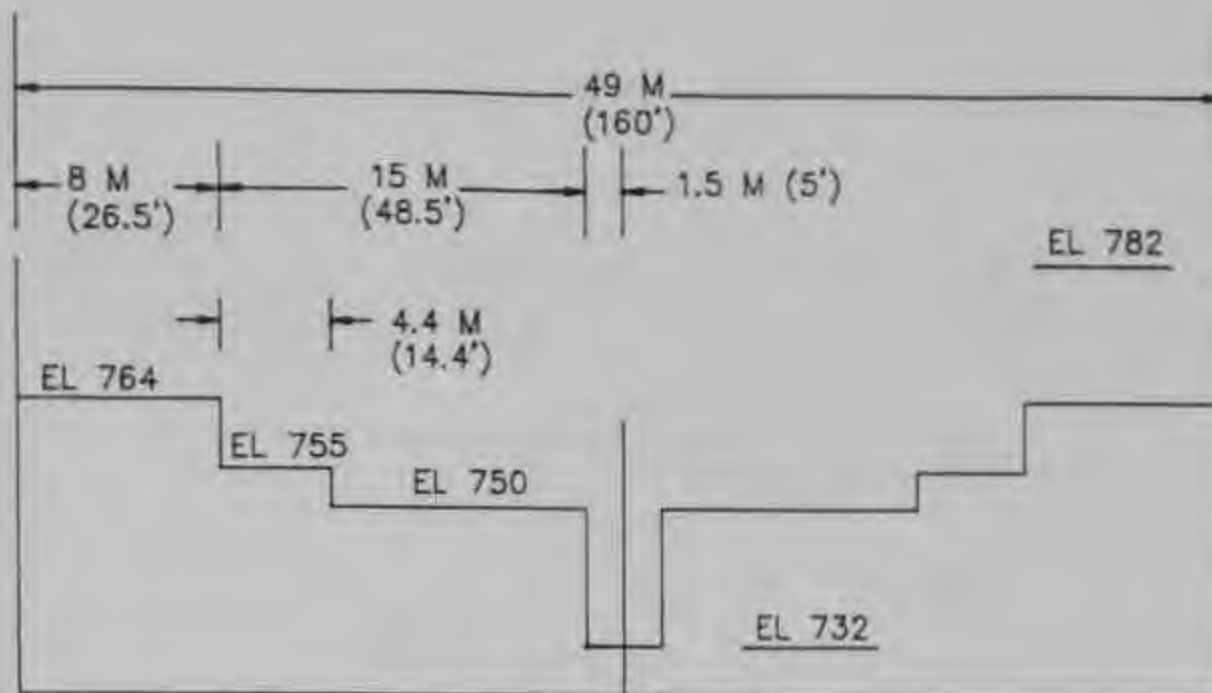

TYPE 2 WEIR - ELEVATION

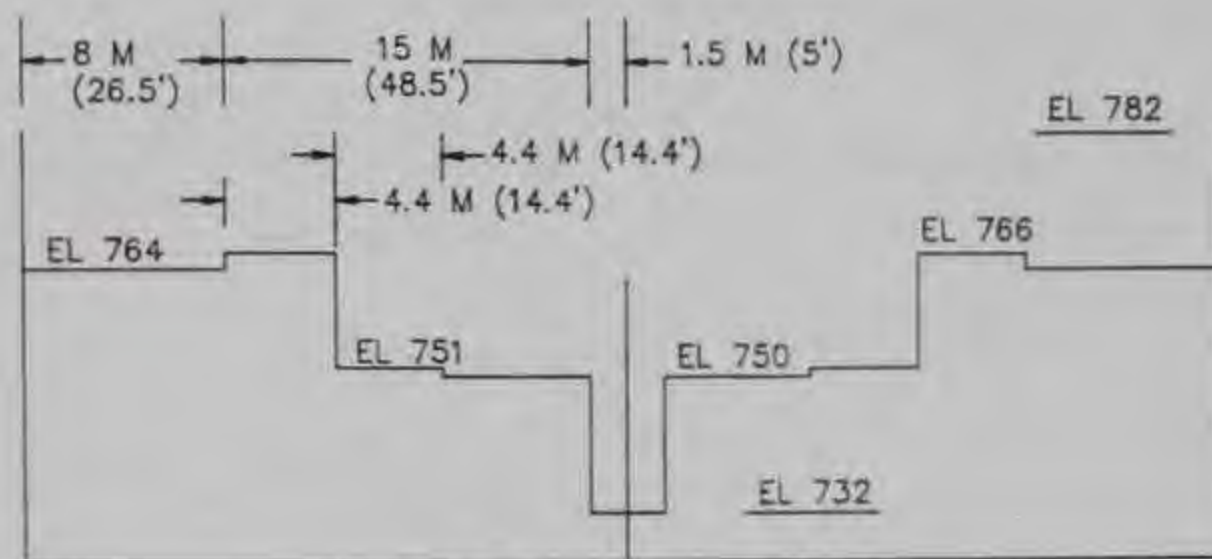

TYPE 3 WEIR - ELEVATION

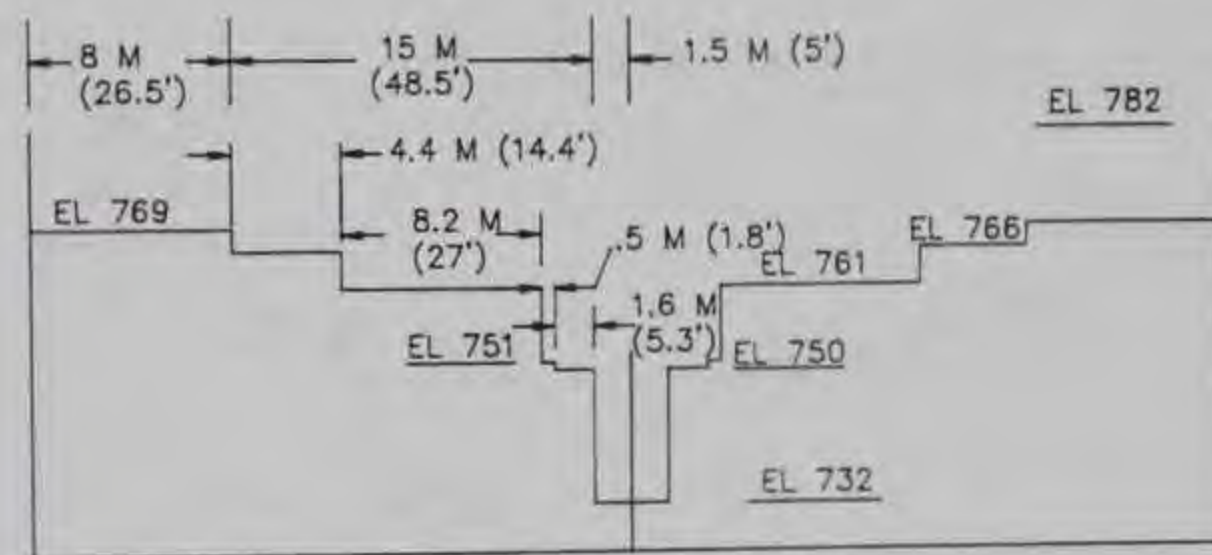

TYPE 4 WEIR - ELEVATION

TYPES 2-4 WEIR DESIGNS

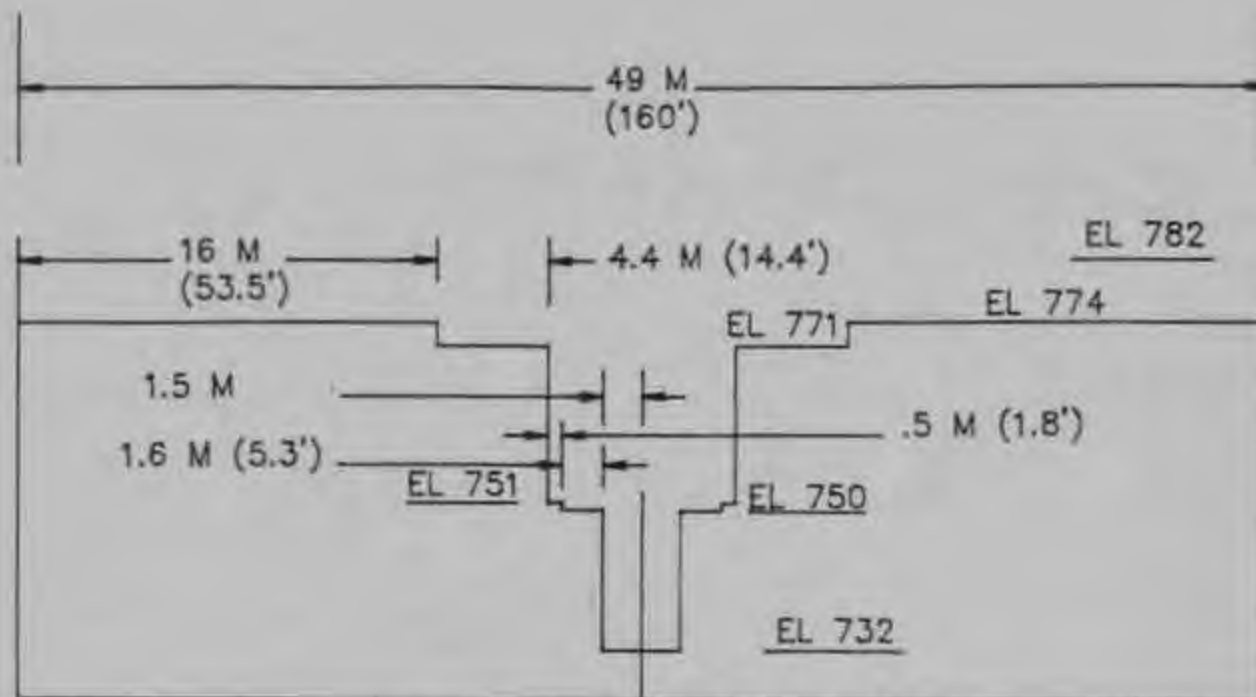

TYPE 5 WEIR - ELEVATION

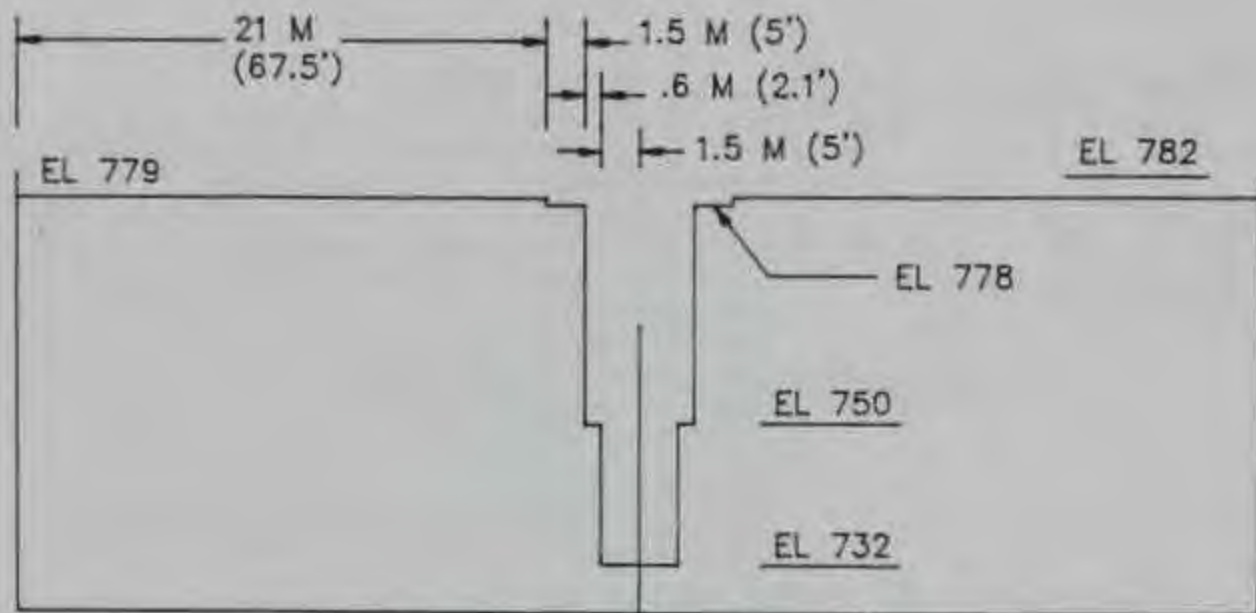

TYPE 6 WEIR - ELEVATION

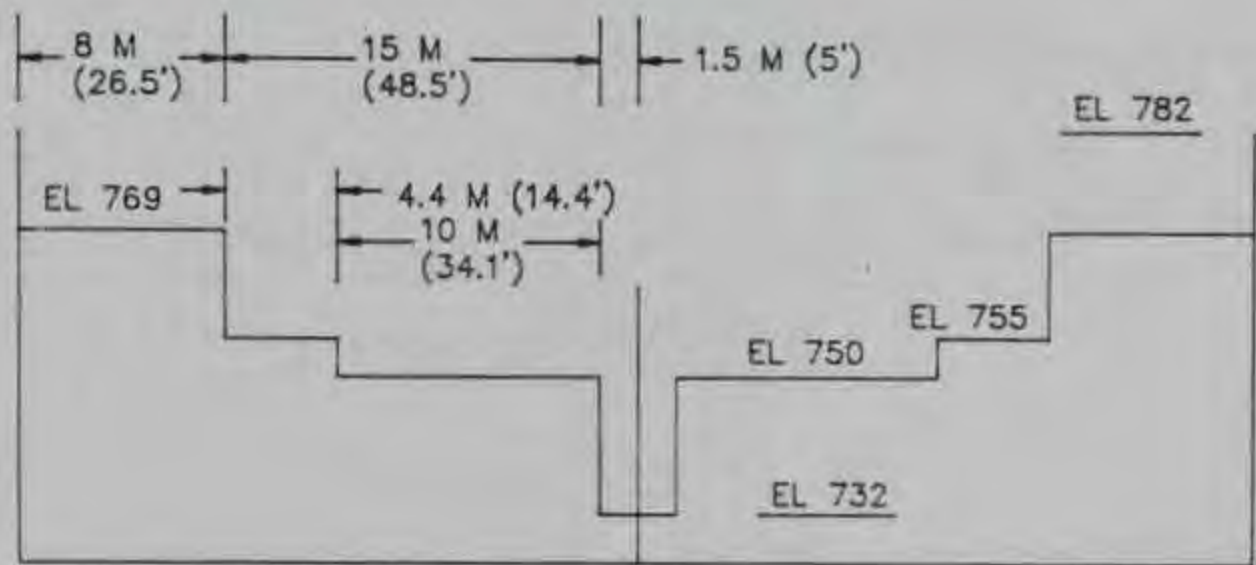

TYPE 7 WEIR - ELEVATION

TYPE 5-7 WEIR DESIGNS

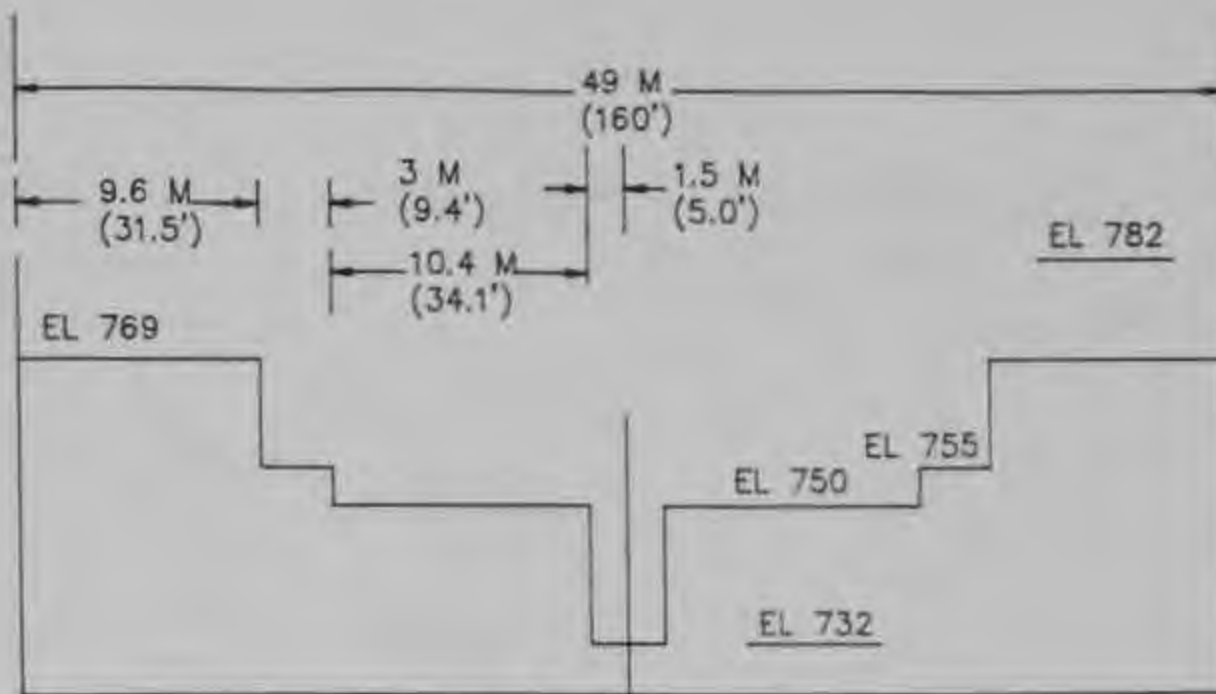

TYPE 8 WEIR - ELEVATION

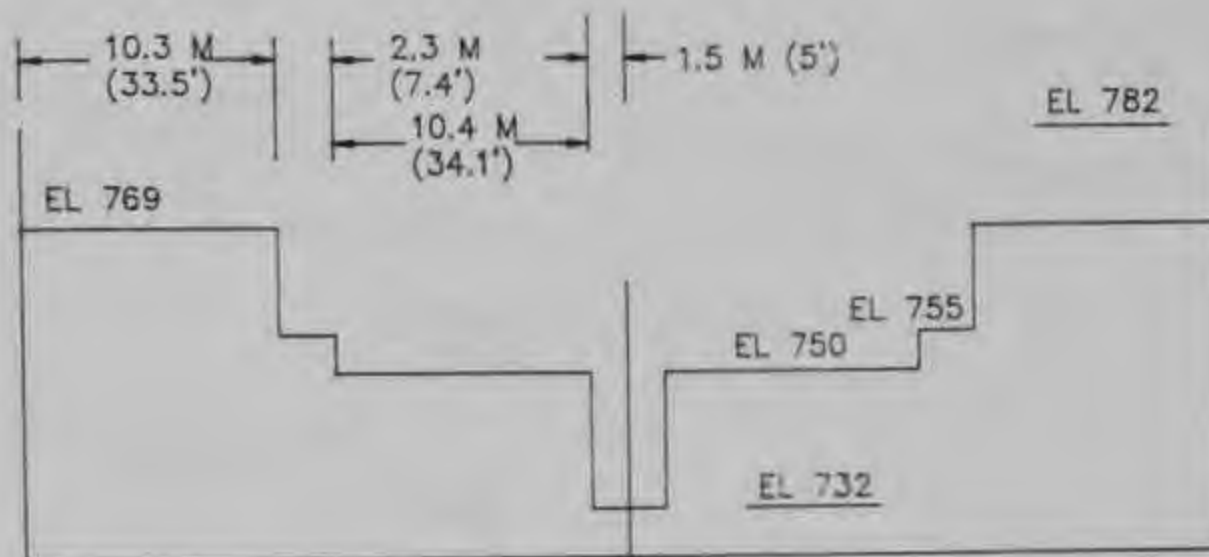

TYPE 9 WEIR - ELEVATION

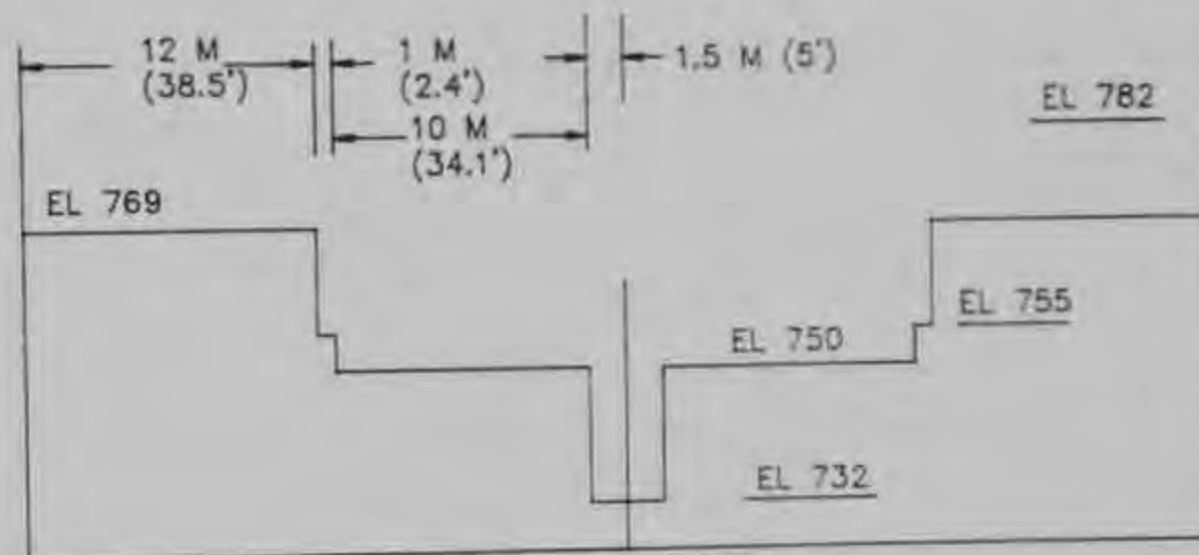

TYPE 10 WEIR - ELEVATION

TYPE 8-10 WEIR DESIGNS

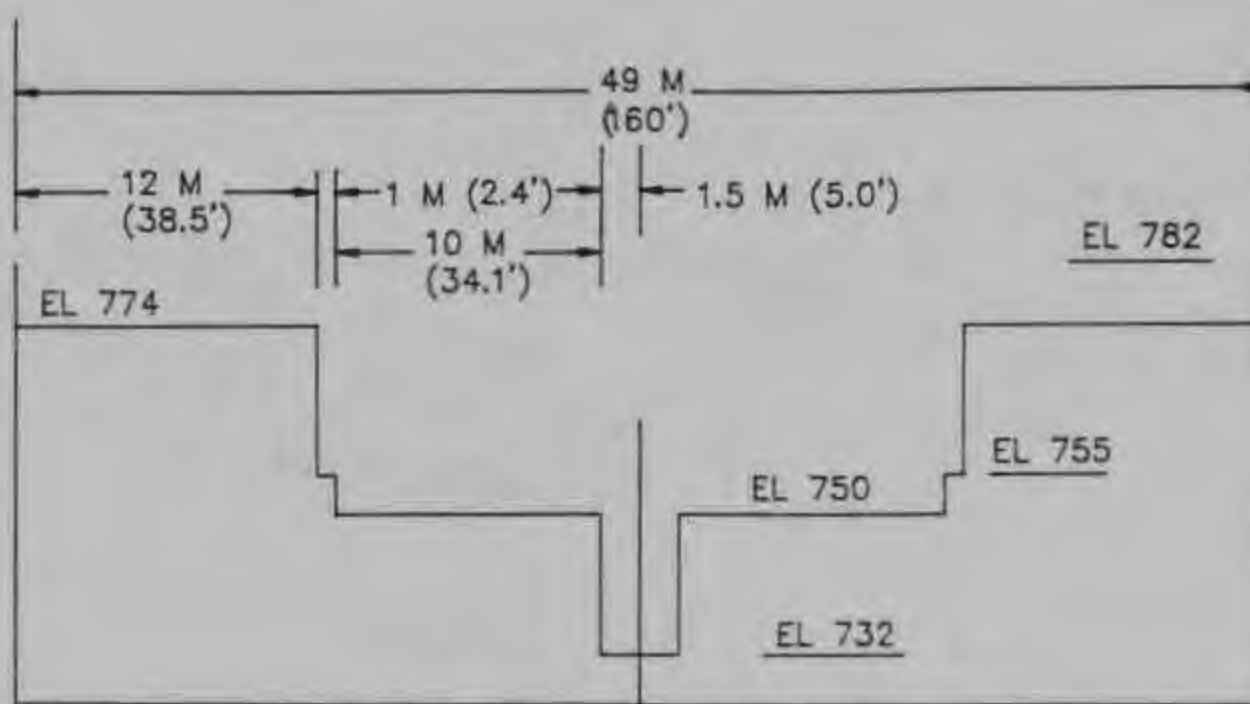

TYPE 11 WEIR - ELEVATION

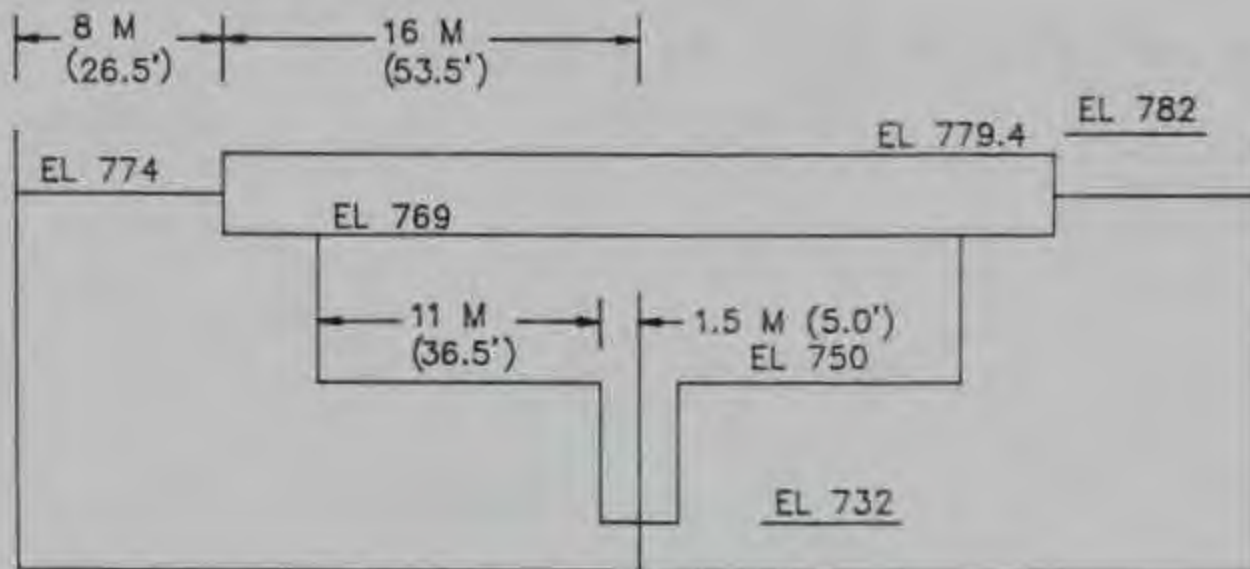

TYPE 12 WEIR - ELEVATION

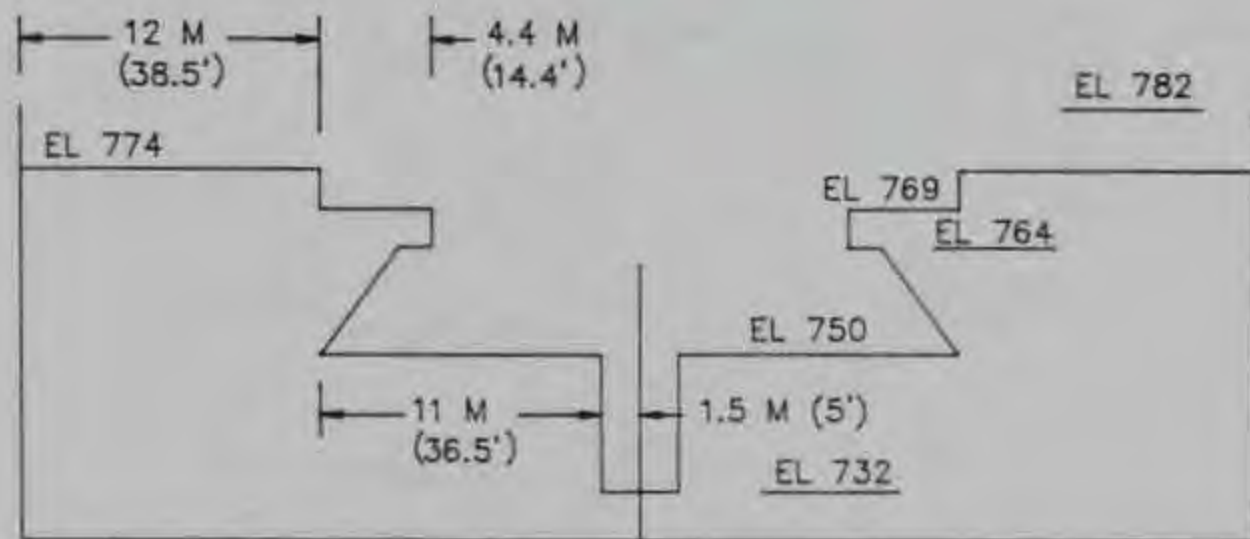

TYPE 13 WEIR - ELEVATION

TYPE 11-13 WEIR DESIGNS

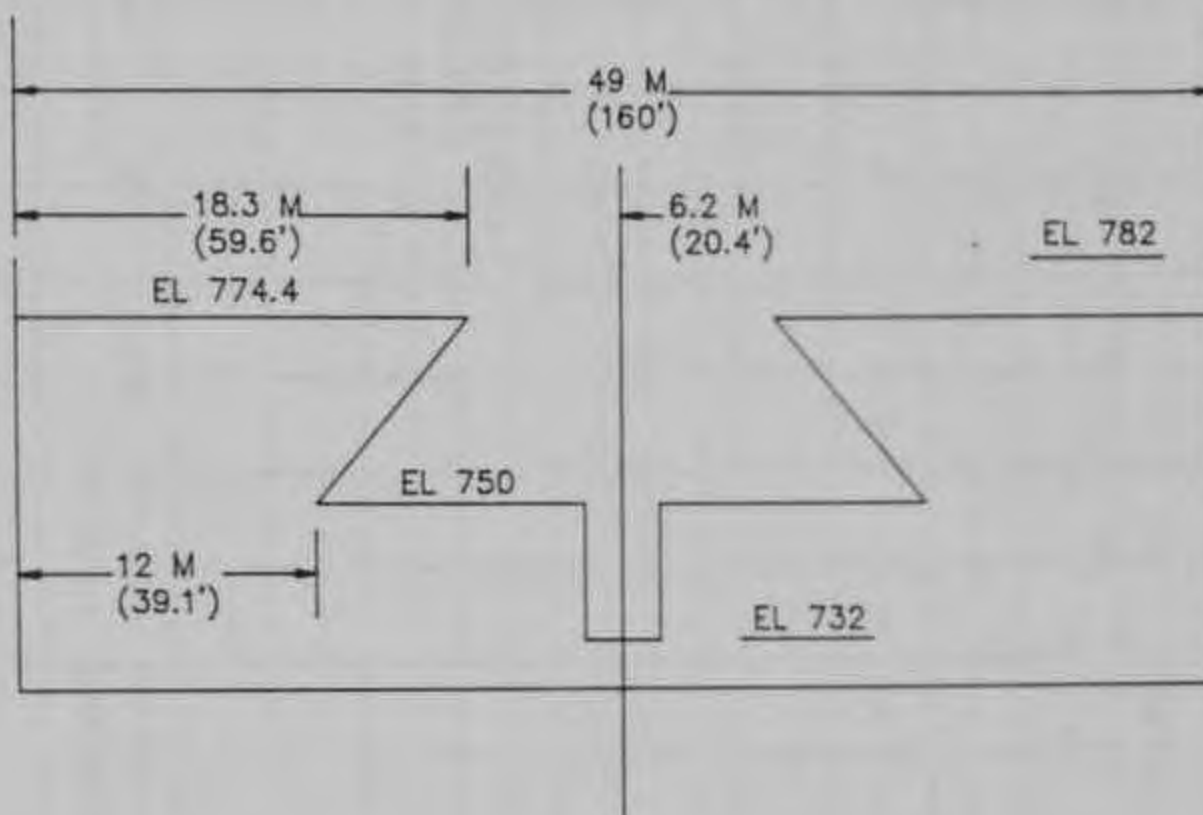

TYPE 14 WEIR - ELEVATION

TYPE 14 WEIR DESIGN

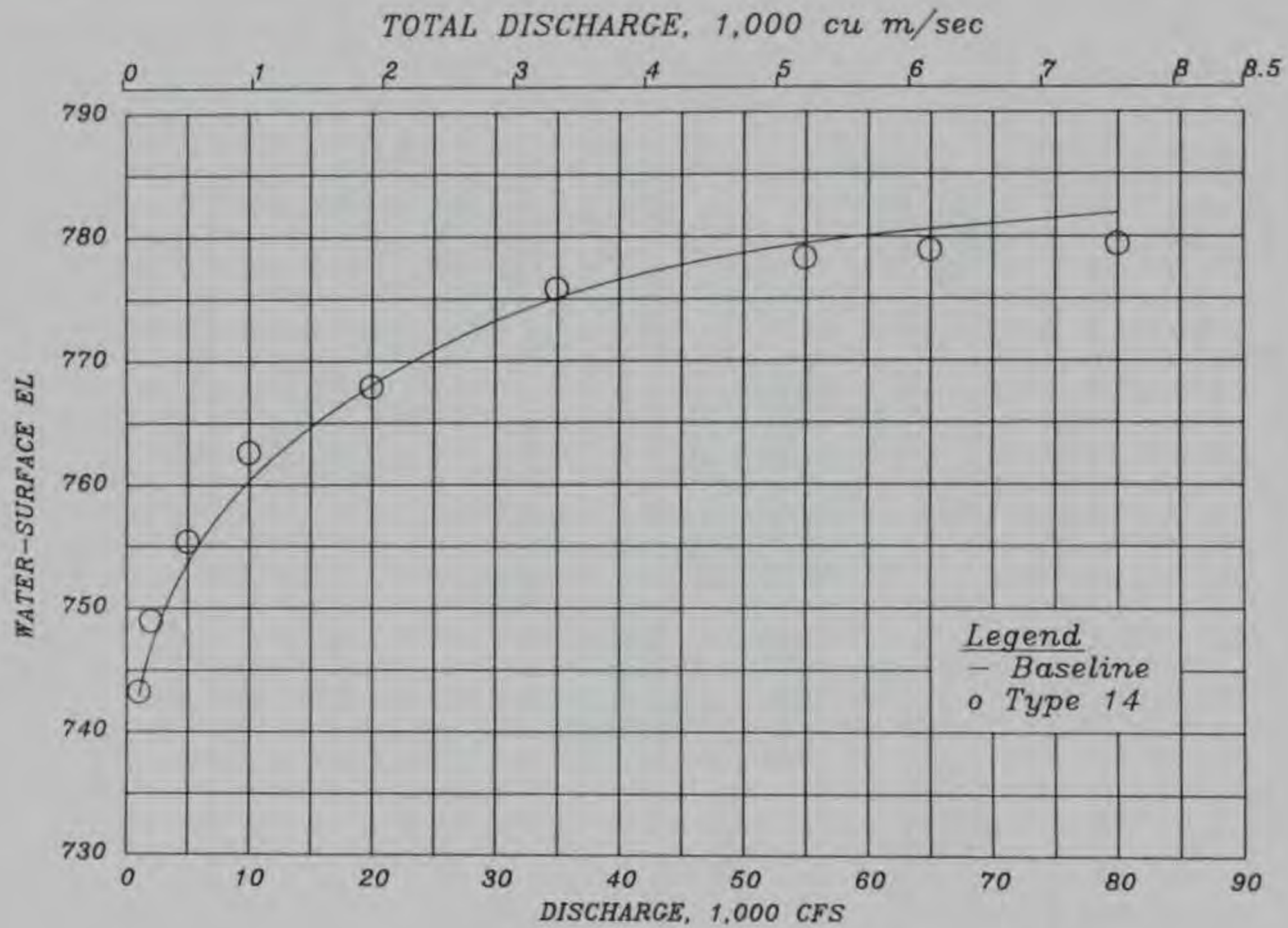

TYPE 14 WEIR
STAGE-DISCHARGE CURVE
STA 102+00

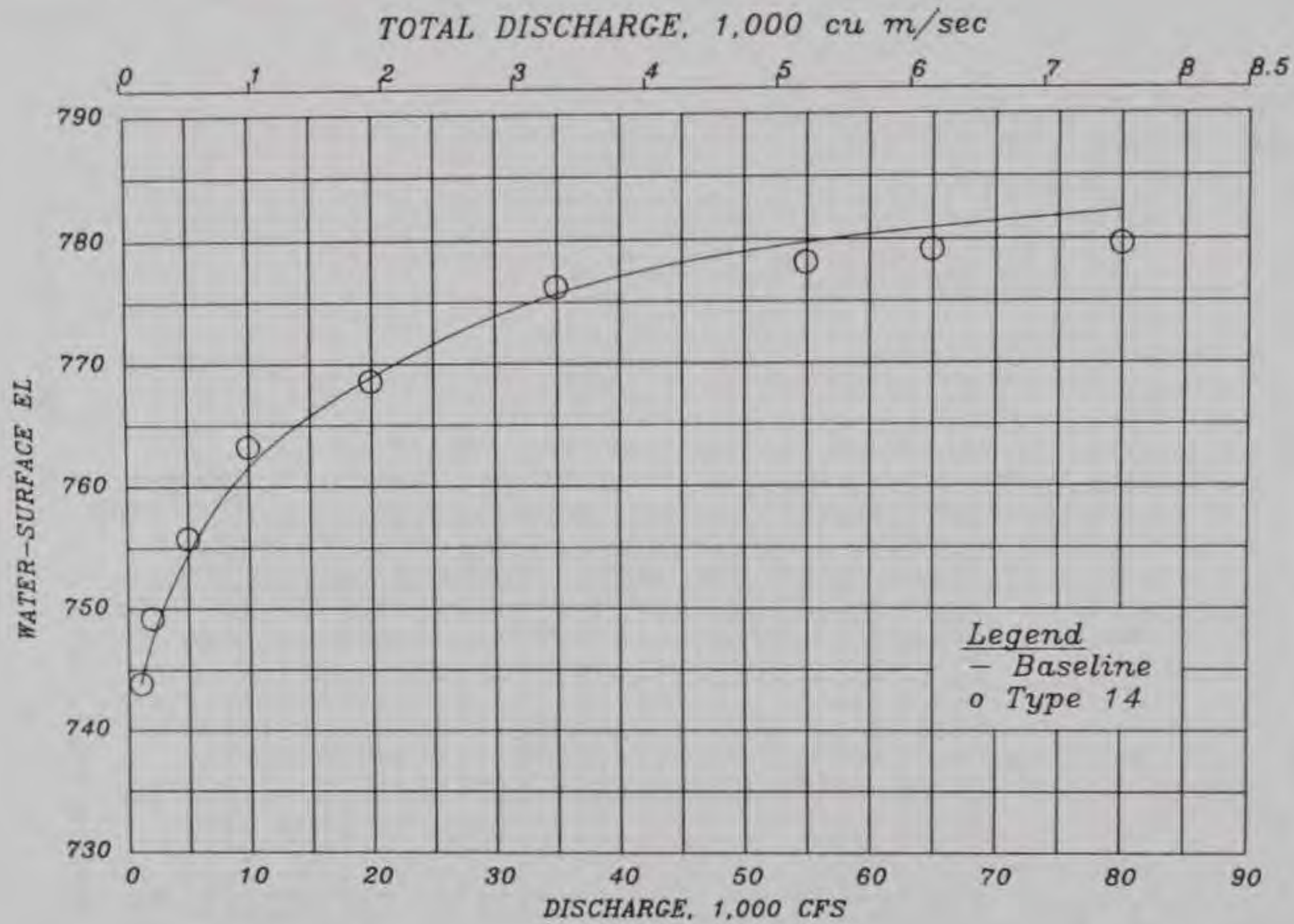

TYPE 14 WEIR
 STAGE-DISCHARGE CURVE
 STA 113+50

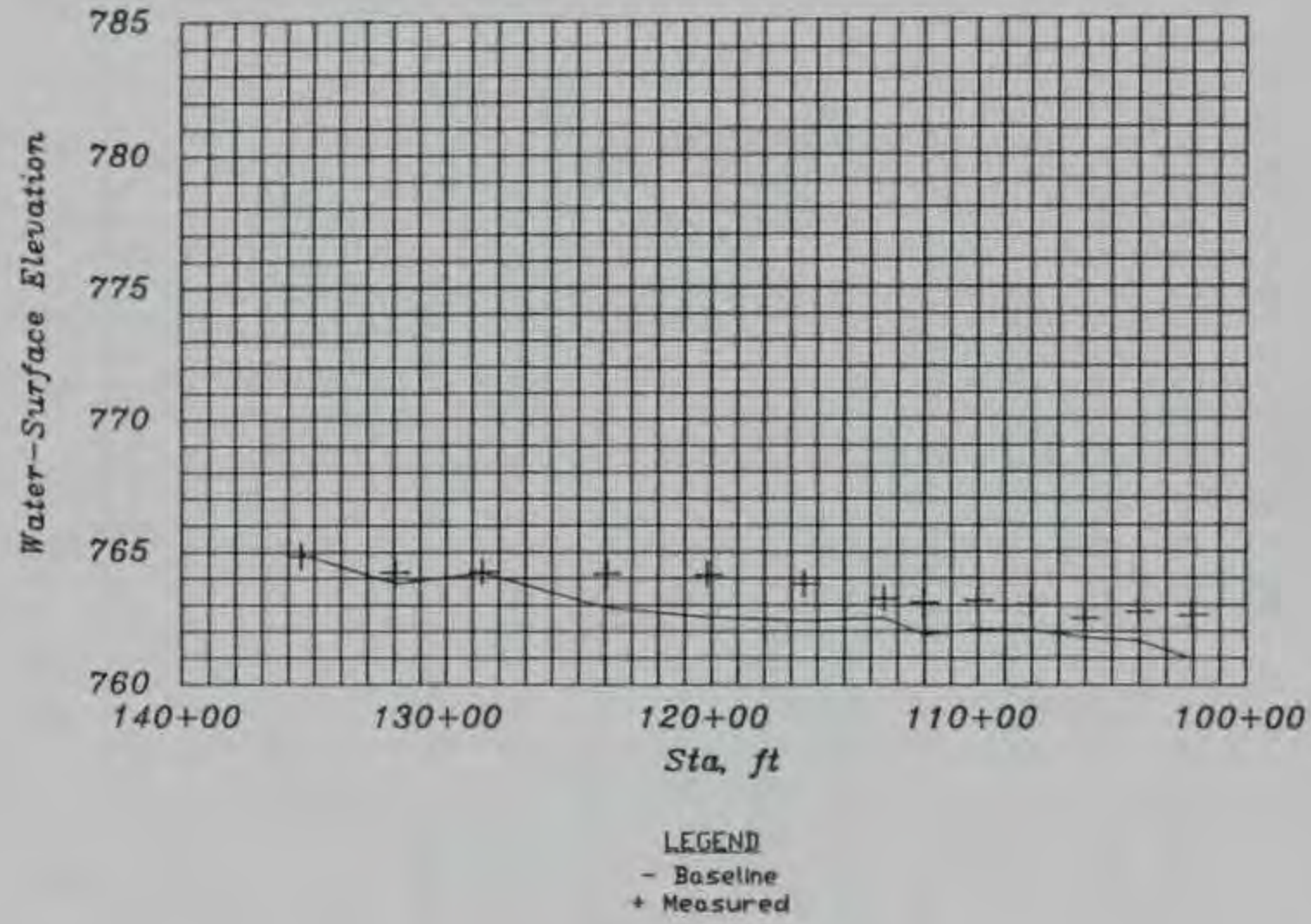

WATER-SURFACE PROFILE
TYPE 14 WEIR
283 CU M/SEC (10,000 CFS)

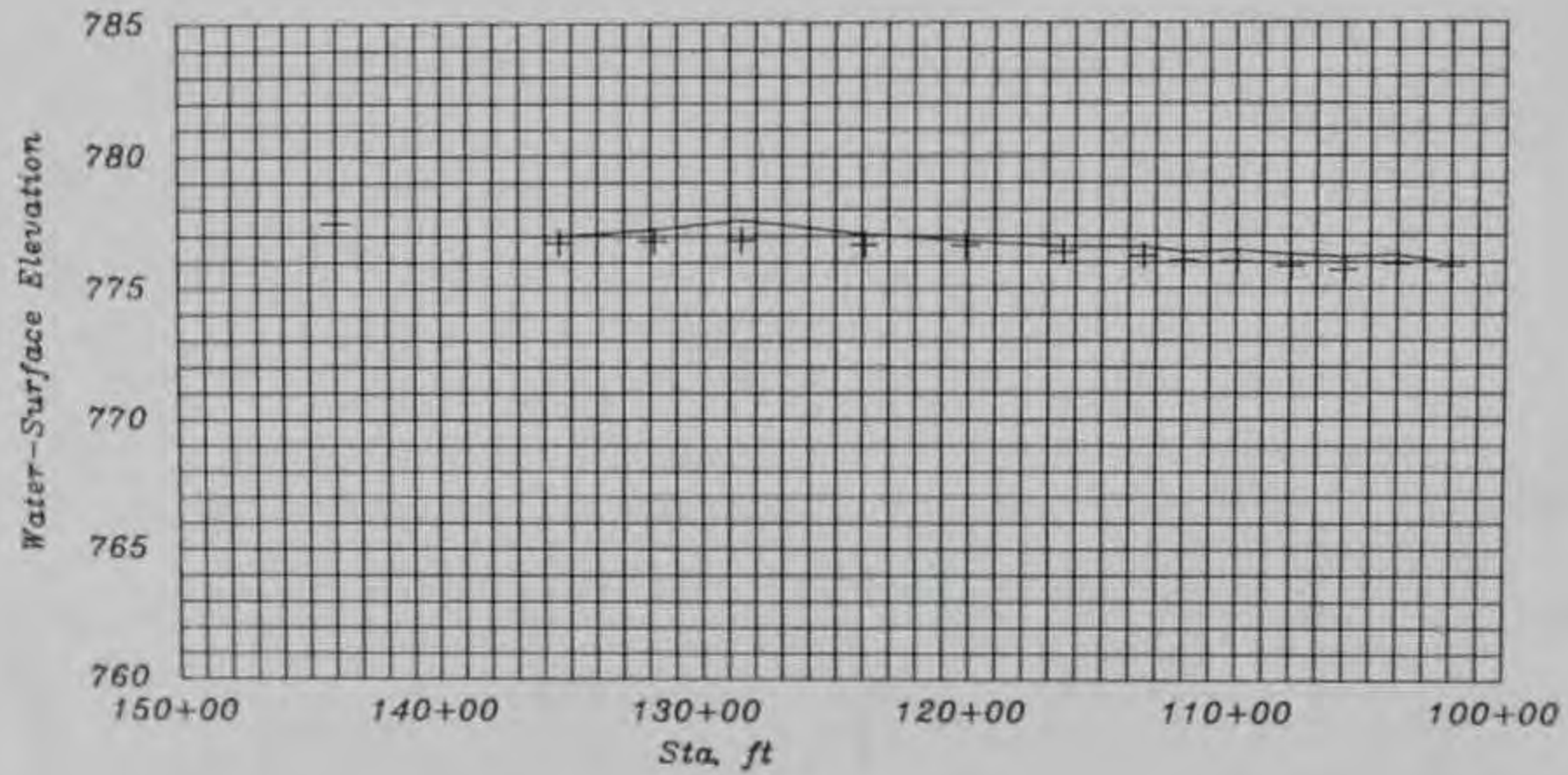

LEGEND
 - Baseline
 + Measured

WATER-SURFACE PROFILE
 TYPE 14 WEIR
 991 CU M/SEC (35,000 CFS)

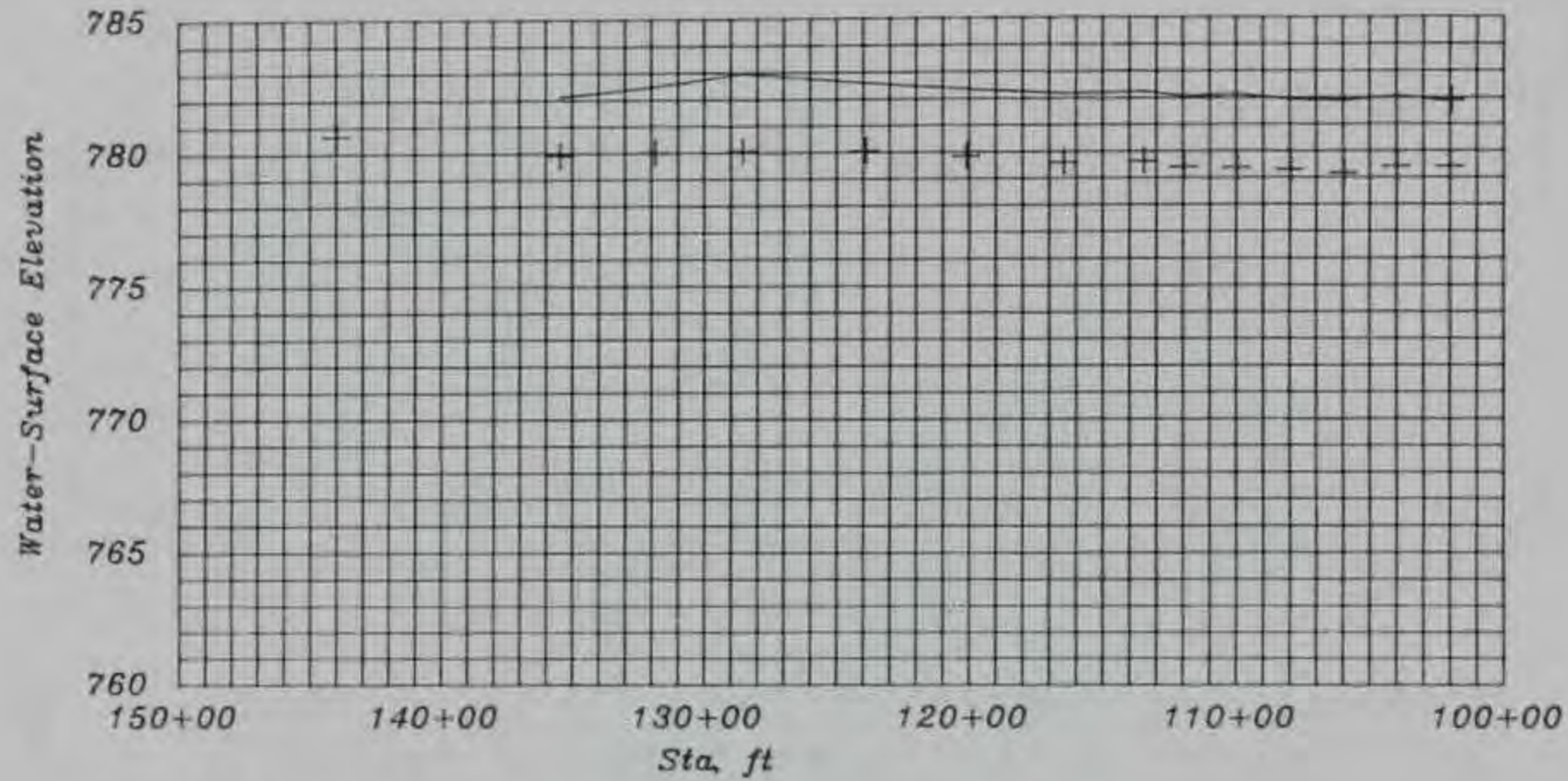

LEGEND
- Baseline
+ Measured

WATER-SURFACE PROFILE
TYPE 14 WEIR
2,265 CU M/SEC (80,000 CFS)

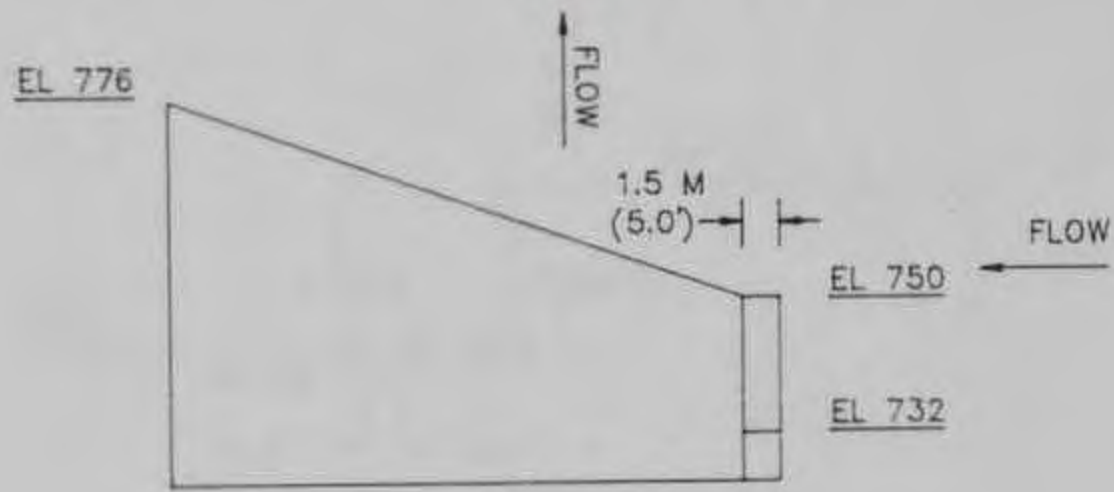
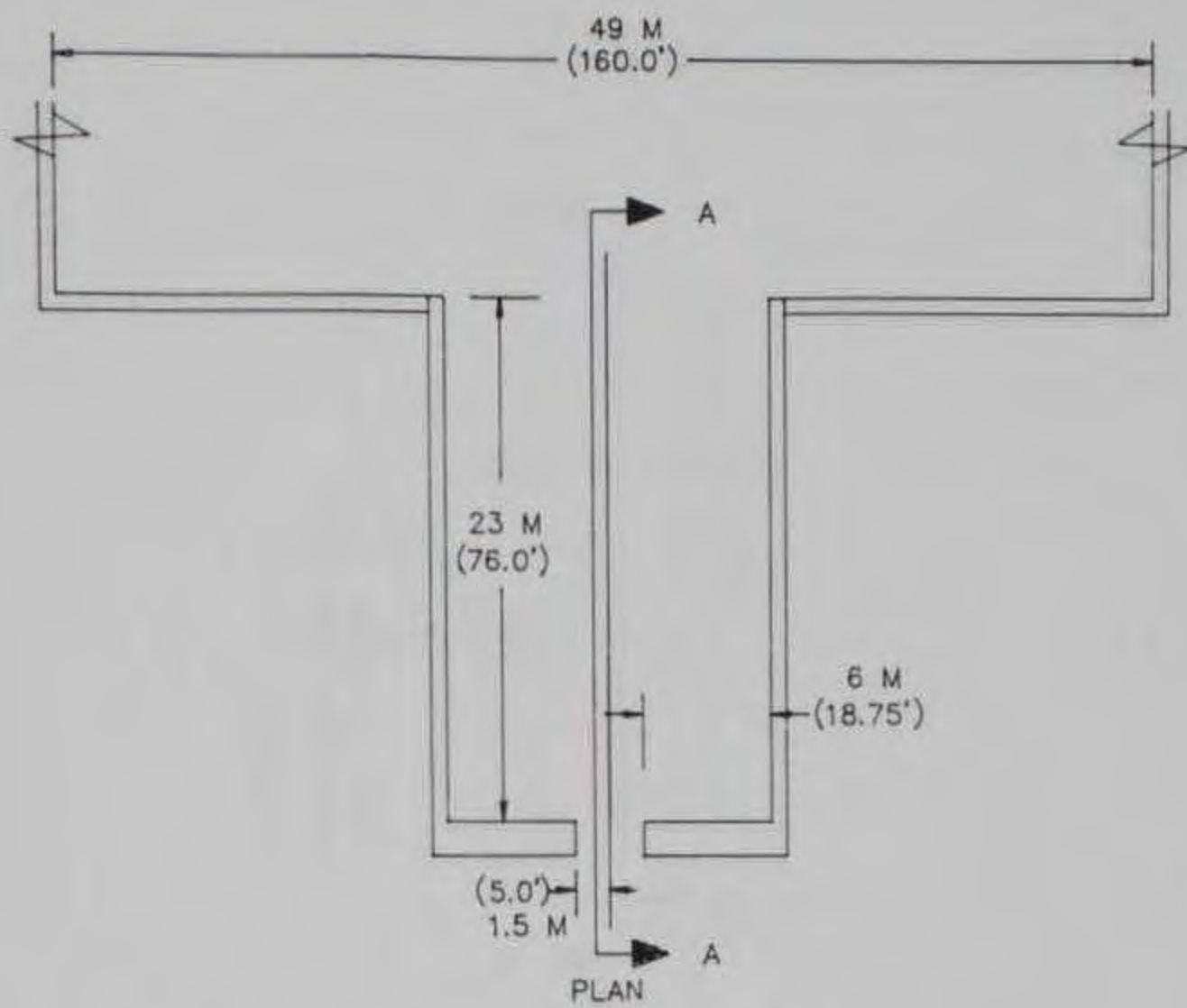

SECTION A-A

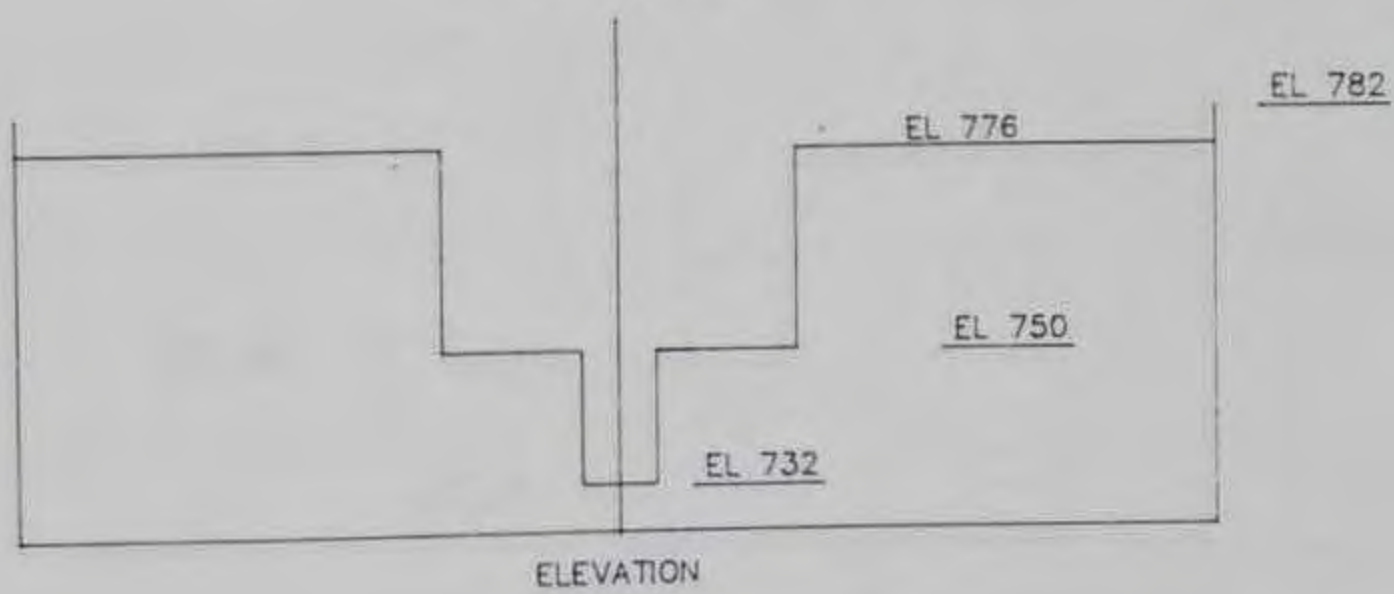

TYPE 15 WEIR DESIGN

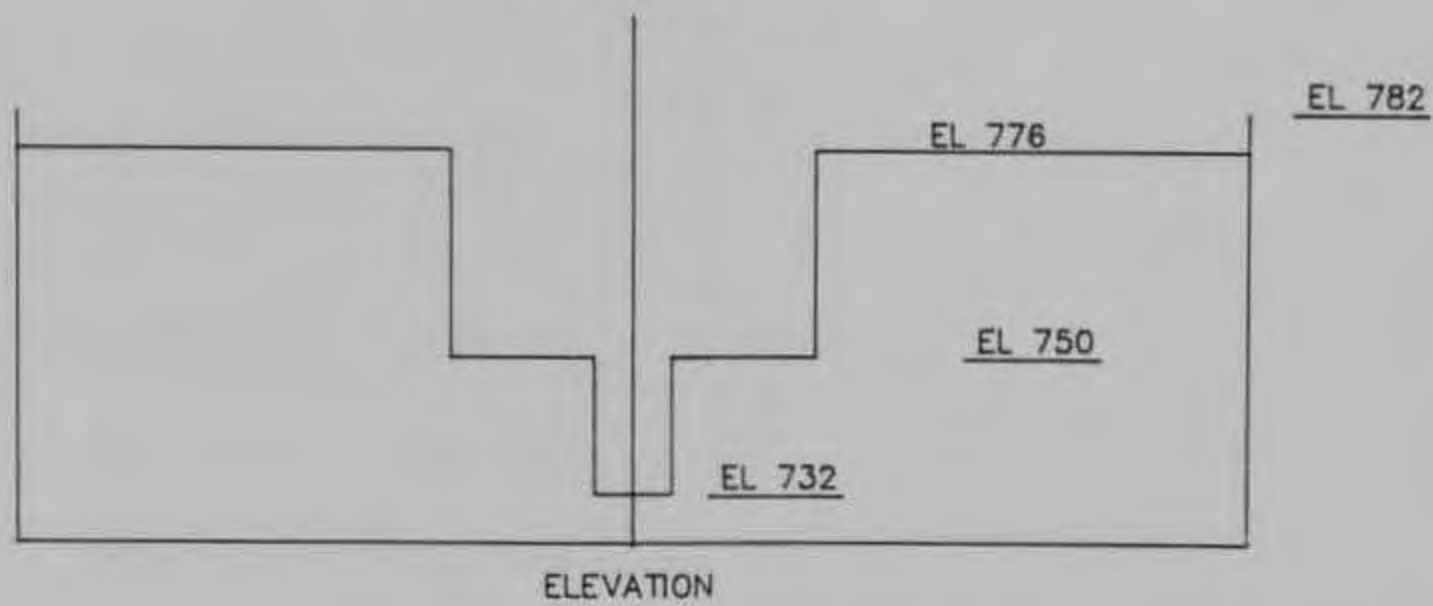
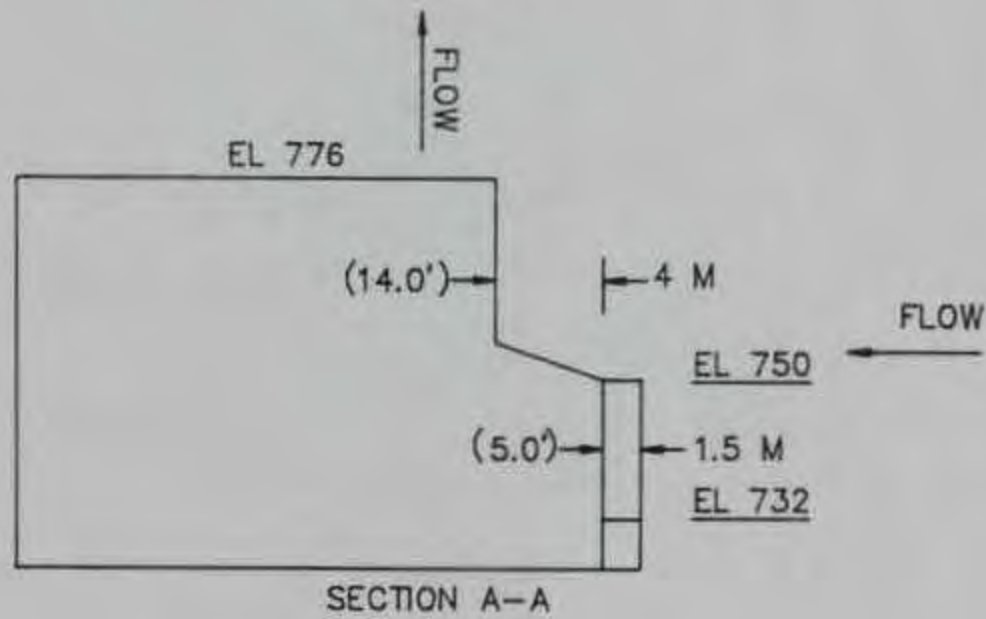
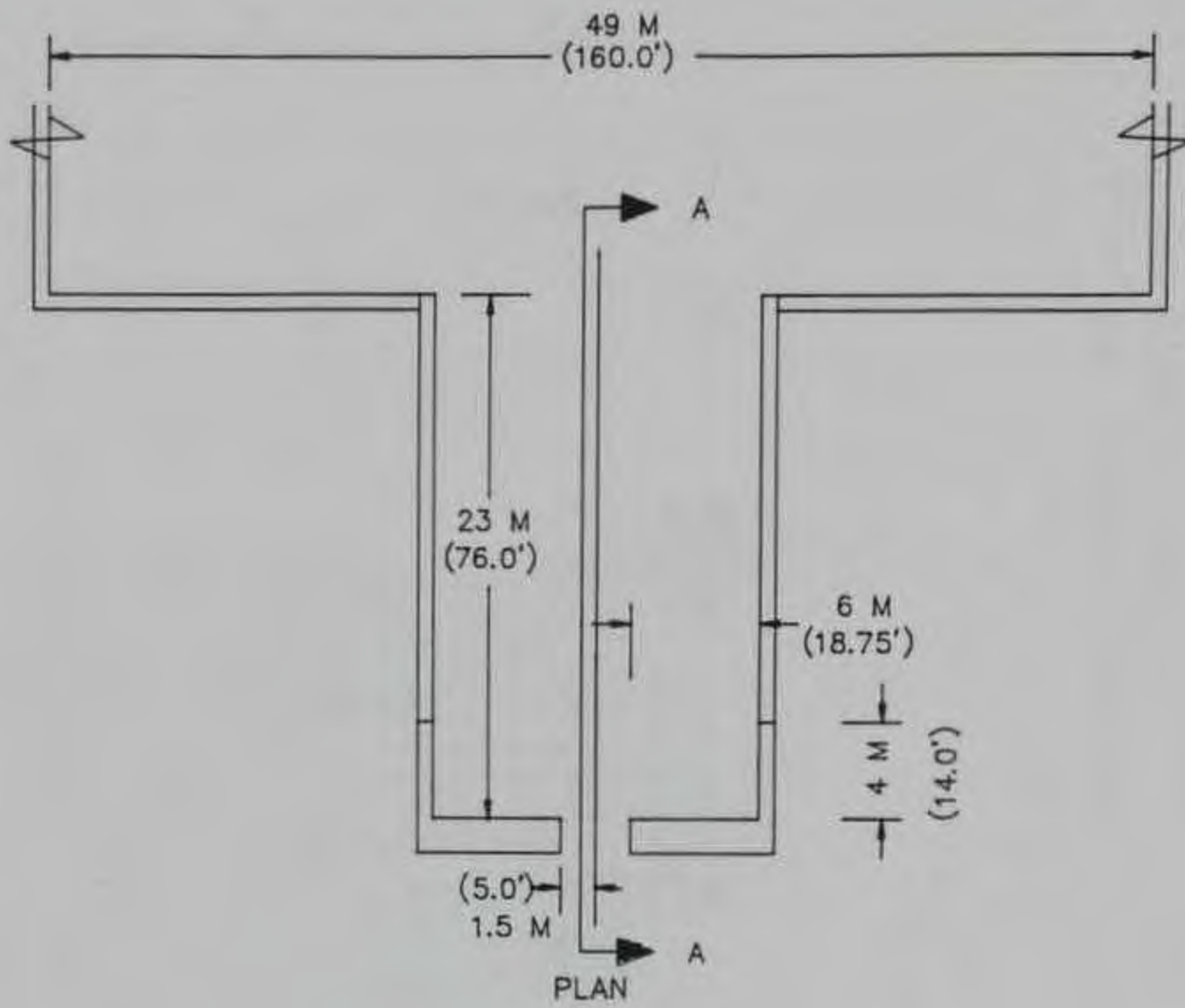

TYPE 16 WEIR DESIGN

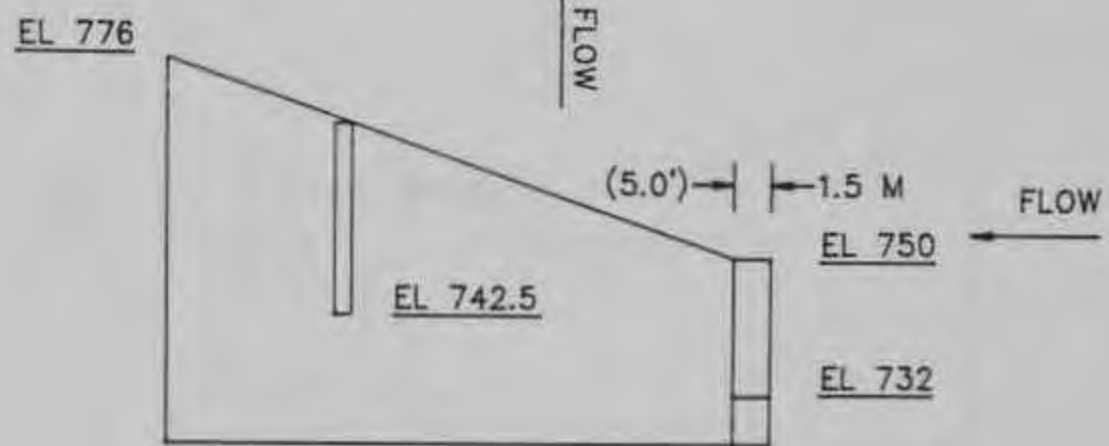
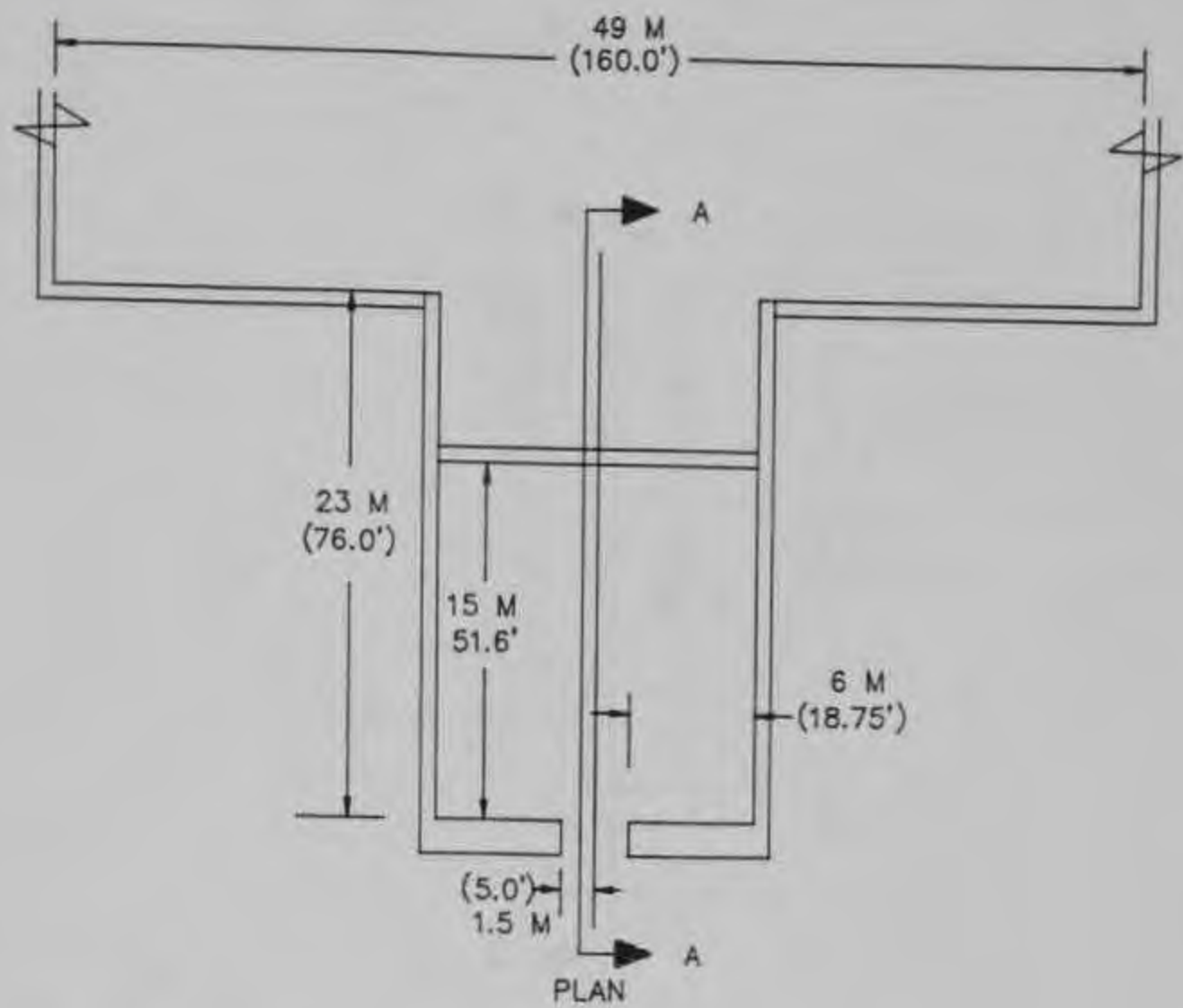

SECTION A-A

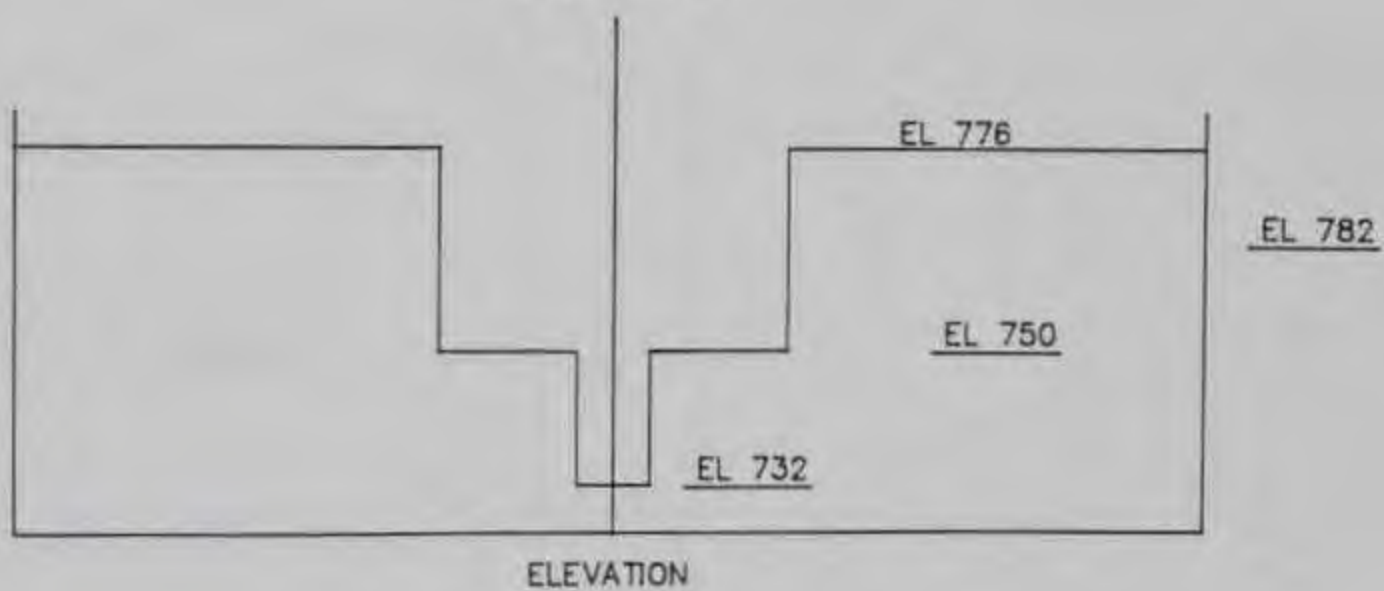

TYPE 17 WEIR DESIGN

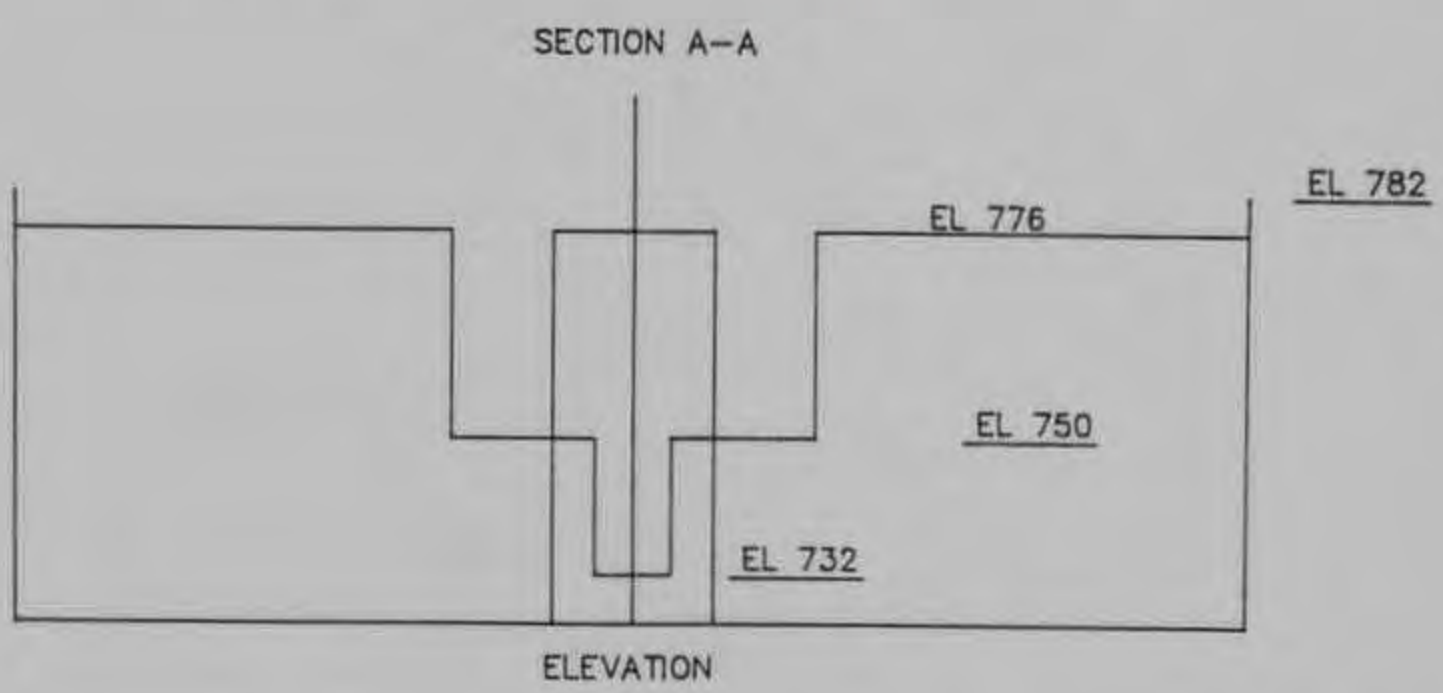
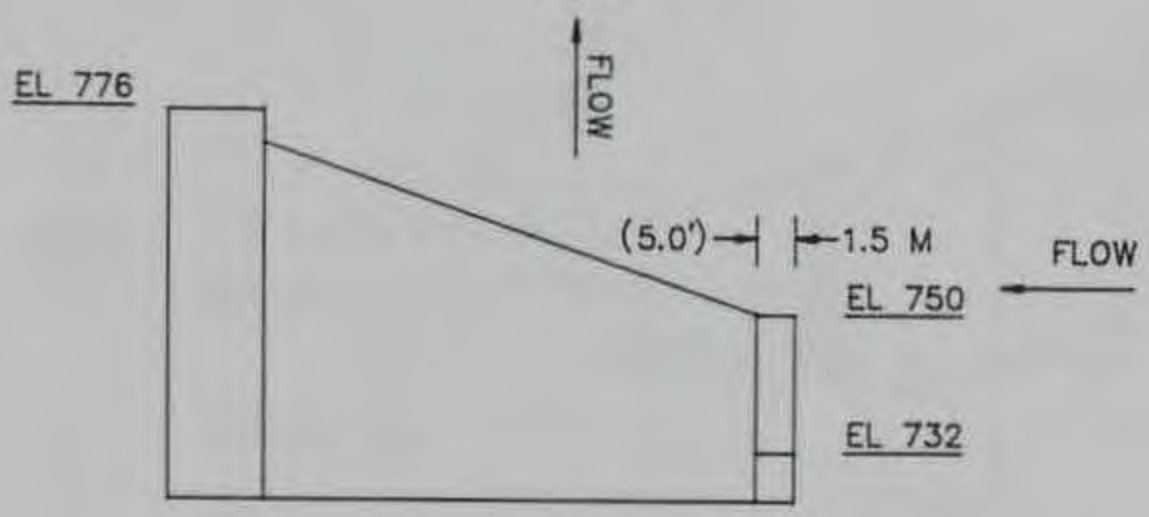
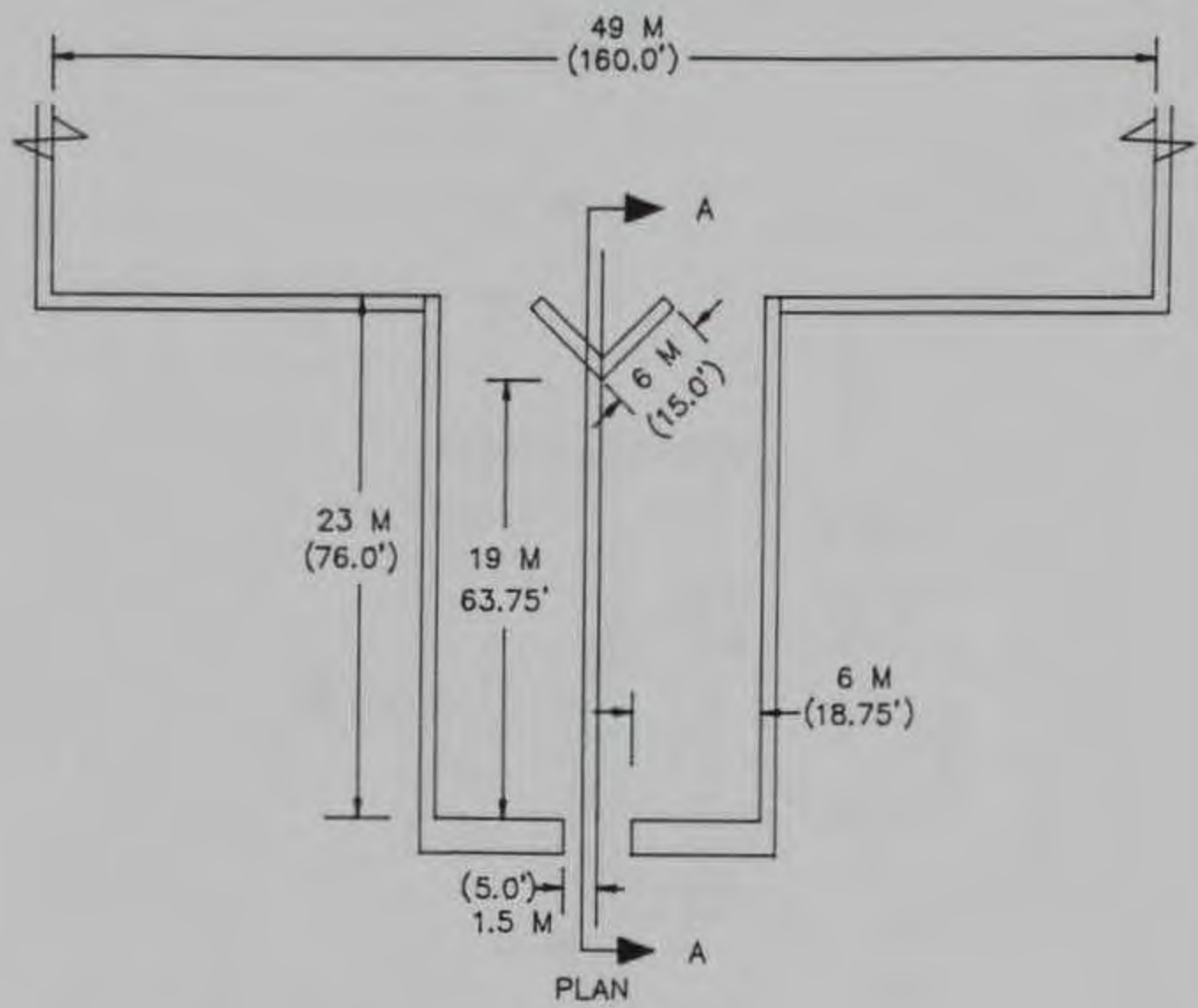

TYPE 18 WEIR DESIGN

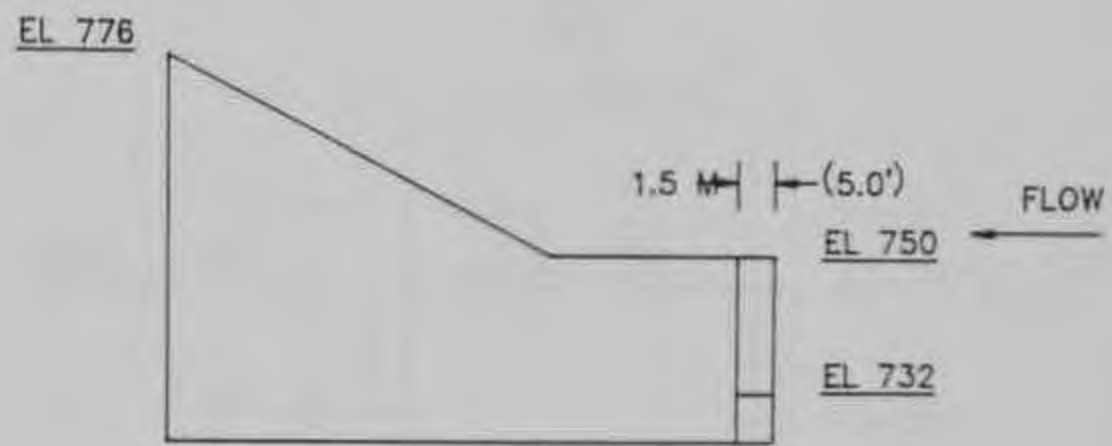
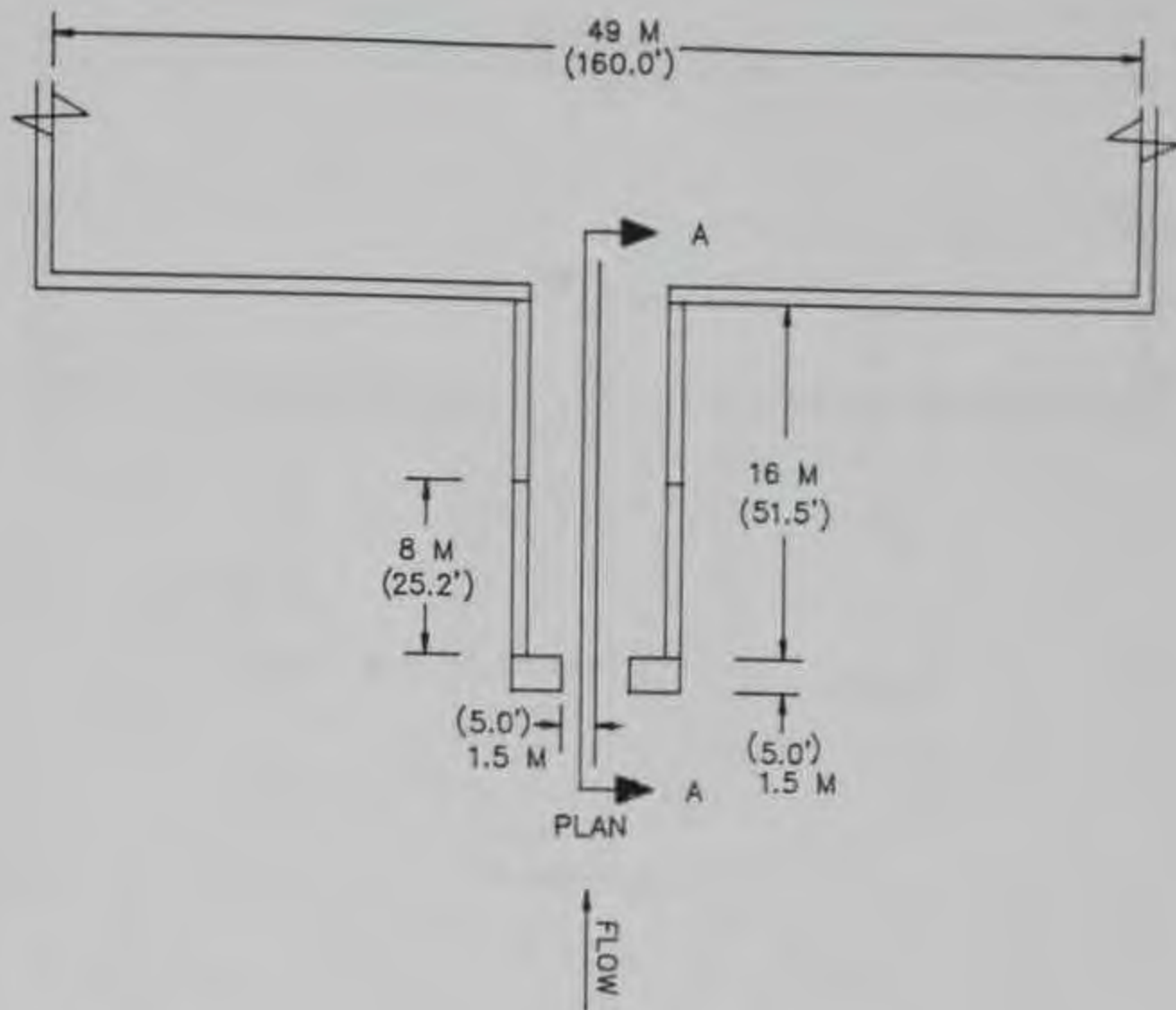

SECTION A-A

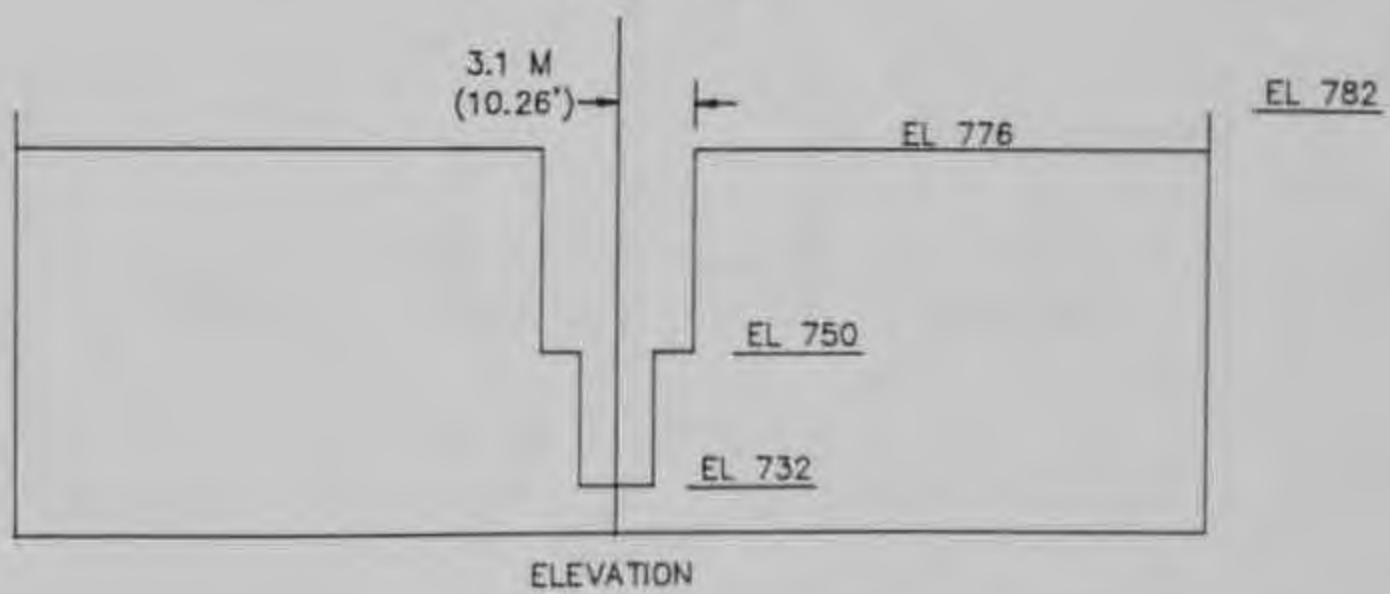

TYPE 19 WEIR DESIGN

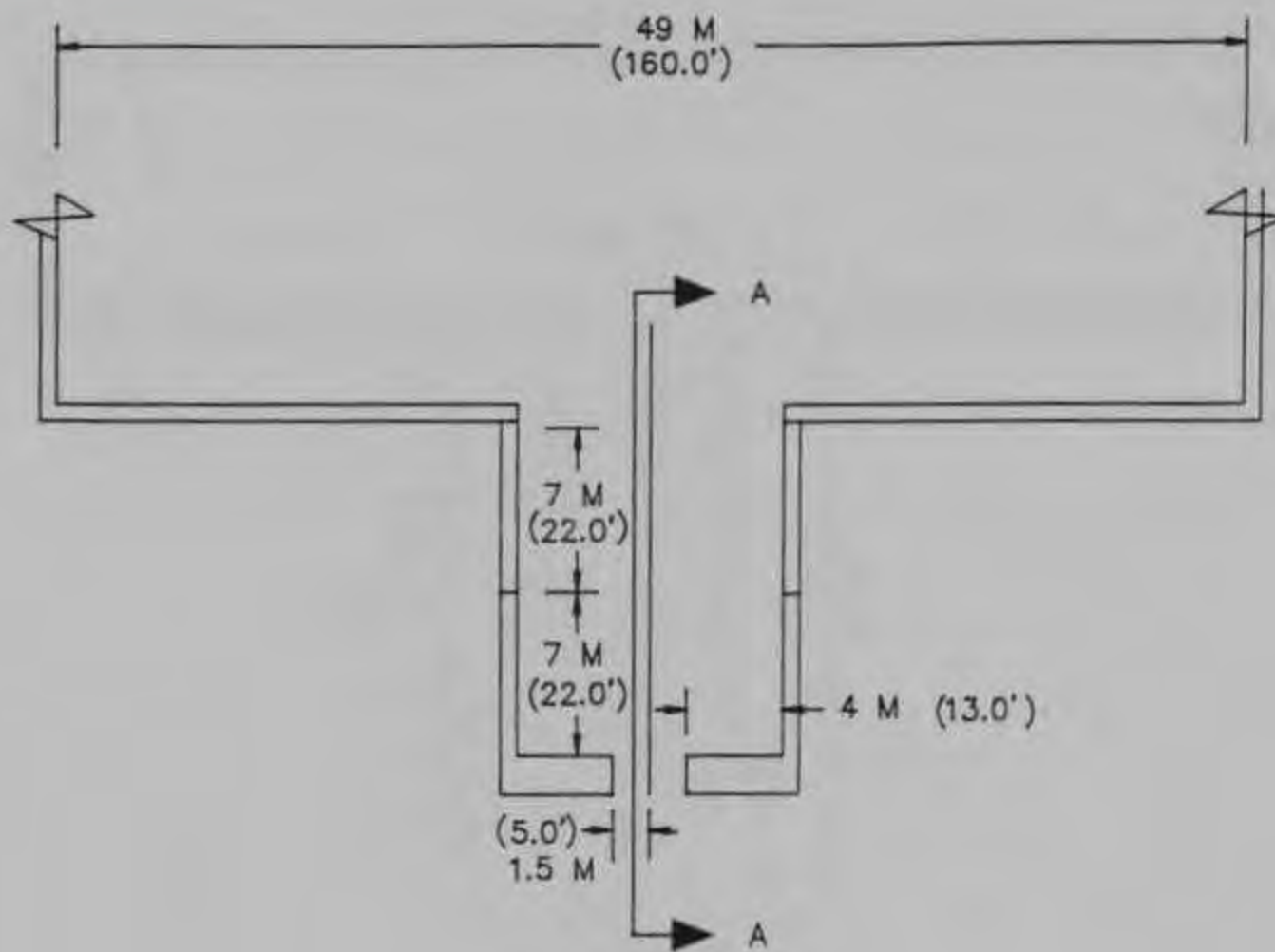

PLAN

↑
FLOW

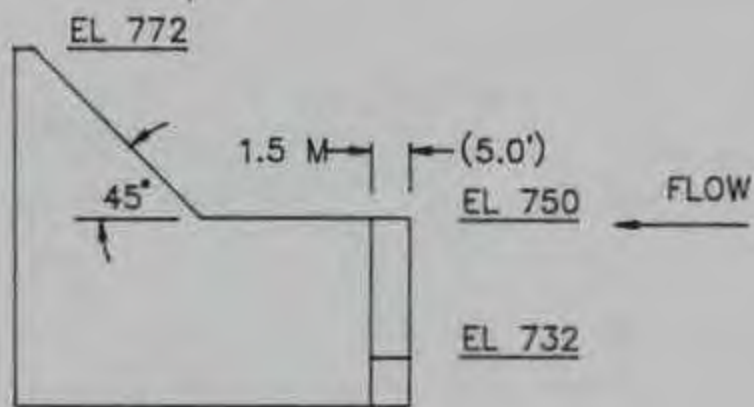

SECTION A-A

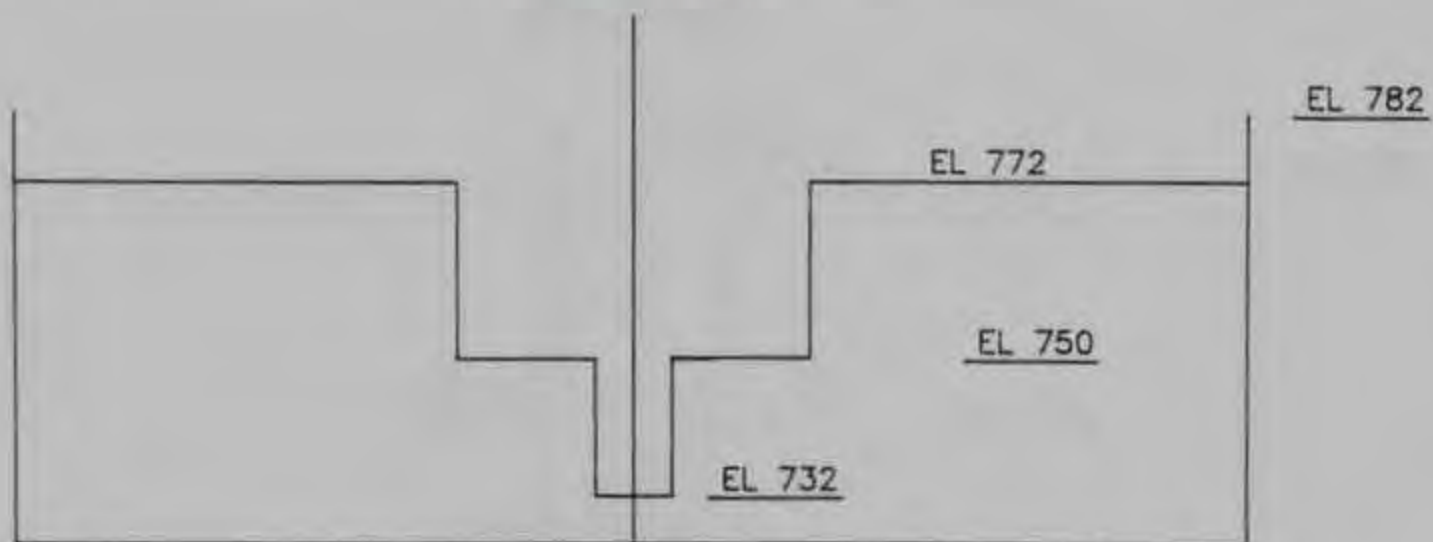

ELEVATION

TYPE 20 WEIR DESIGN

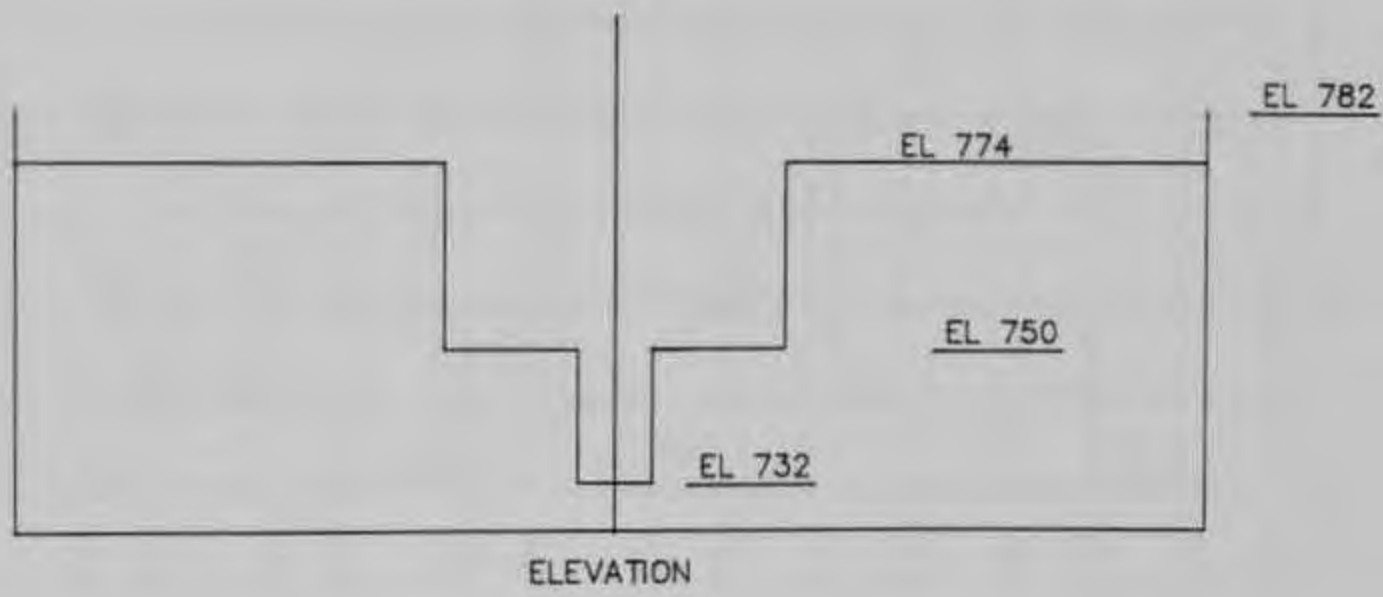
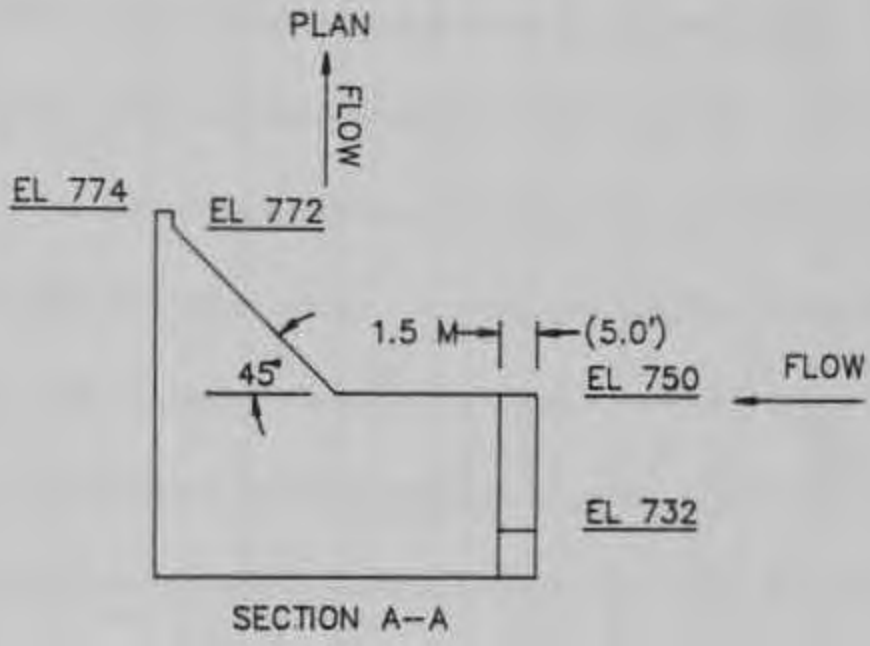
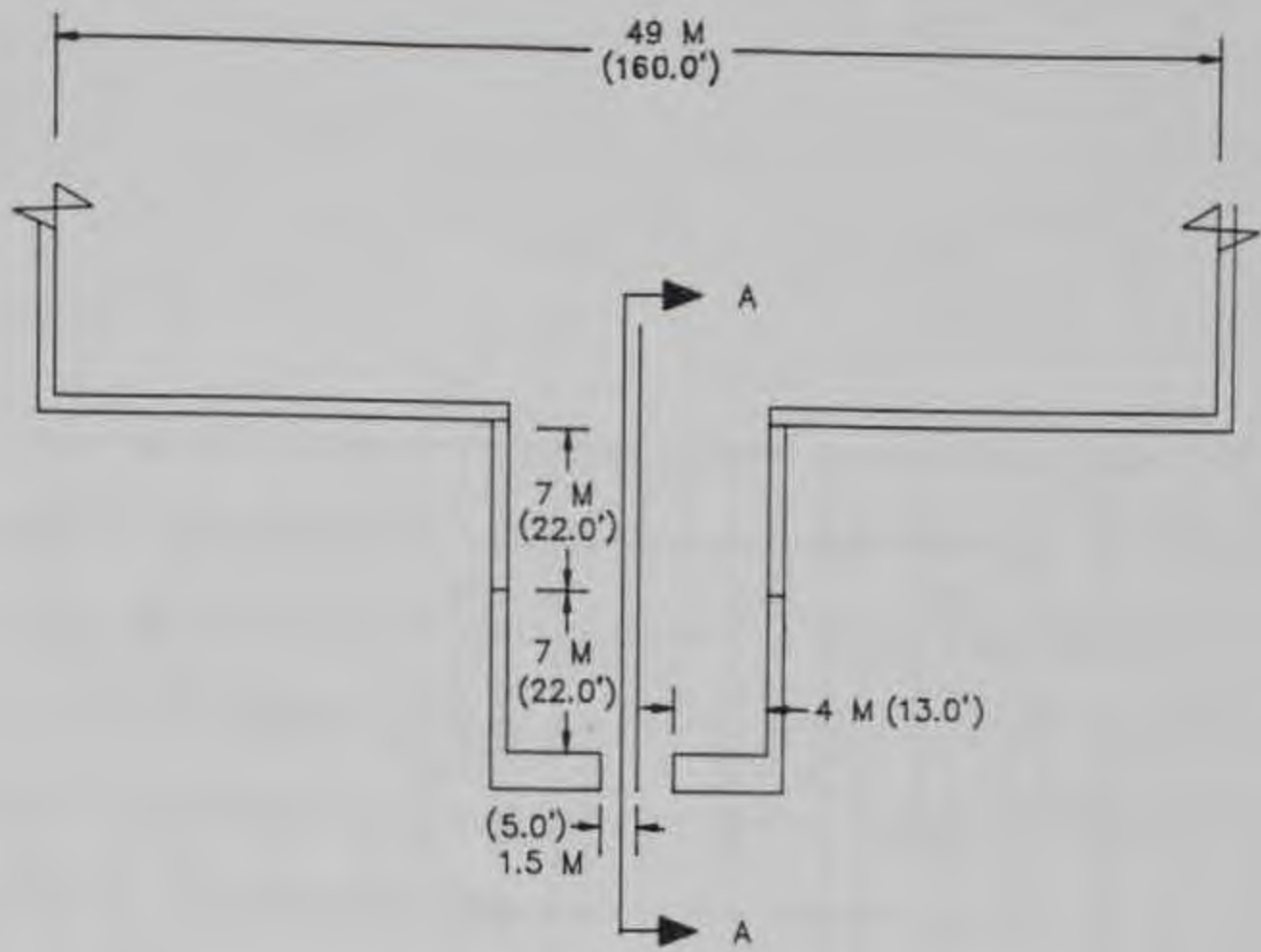

TYPE 21 WEIR DESIGN

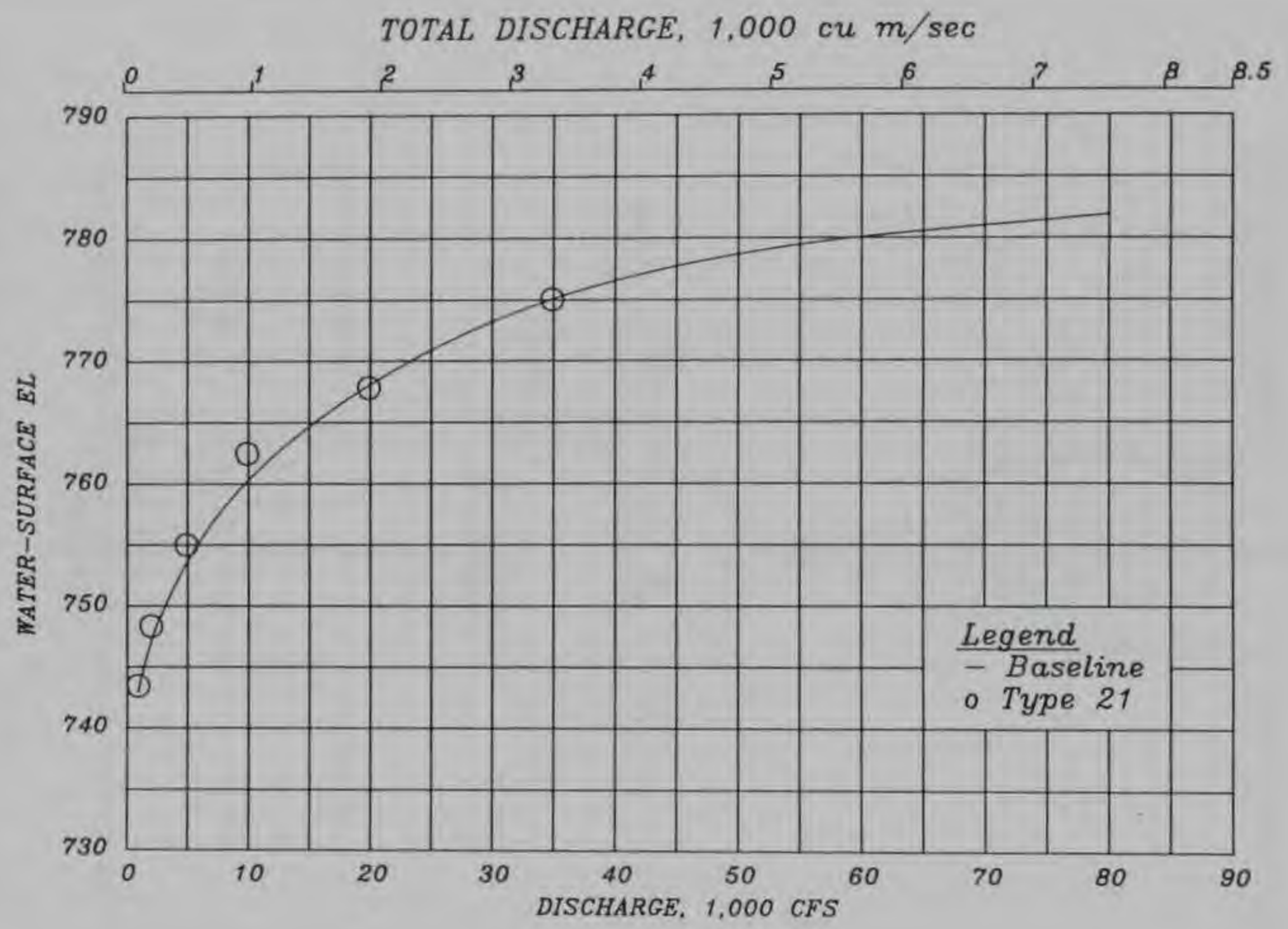

TYPE 21 WEIR
STAGE-DISCHARGE CURVE
STA 102+00

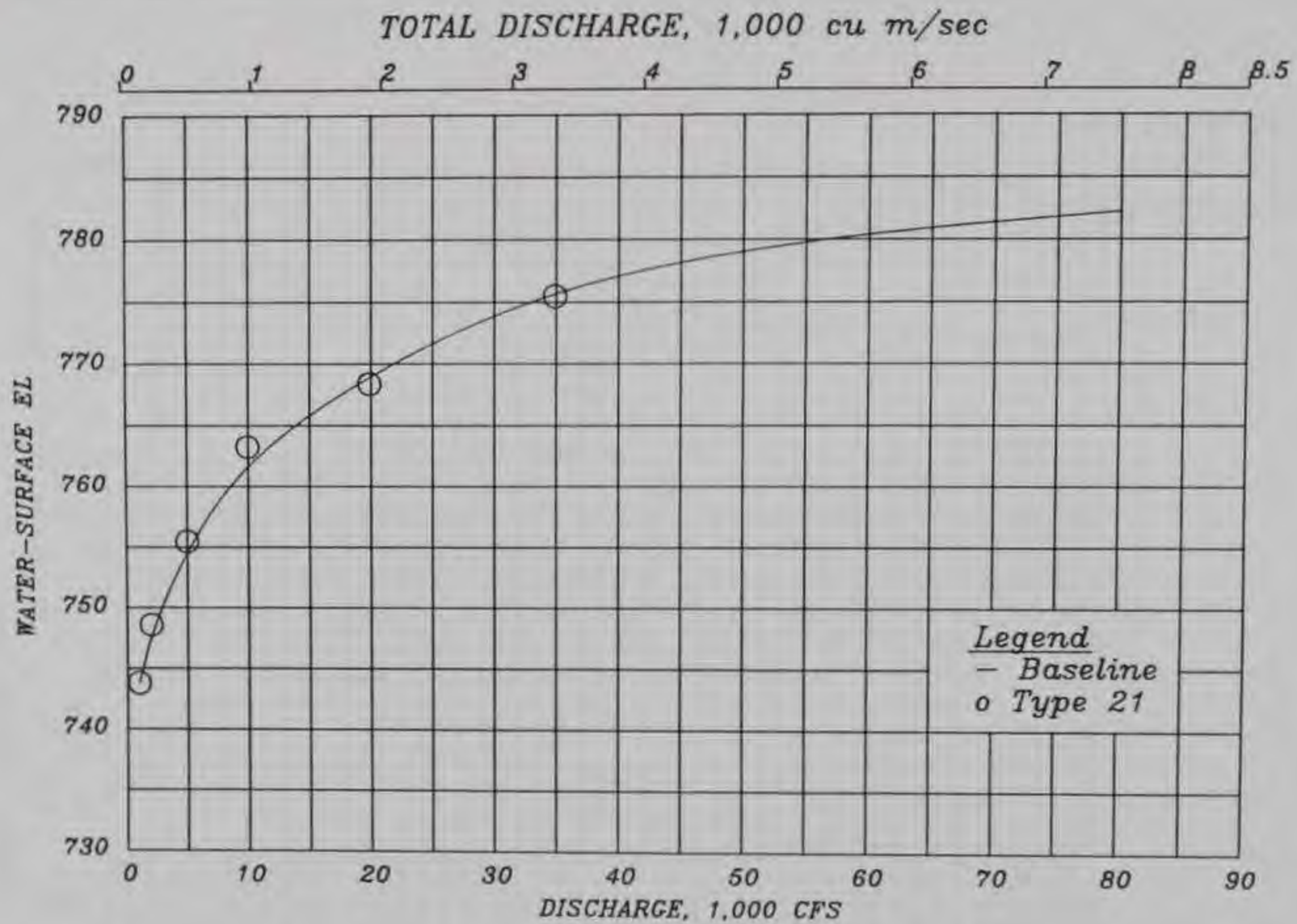

TYPE 21 WEIR
 STAGE-DISCHARGE CURVE
 STA 113+50

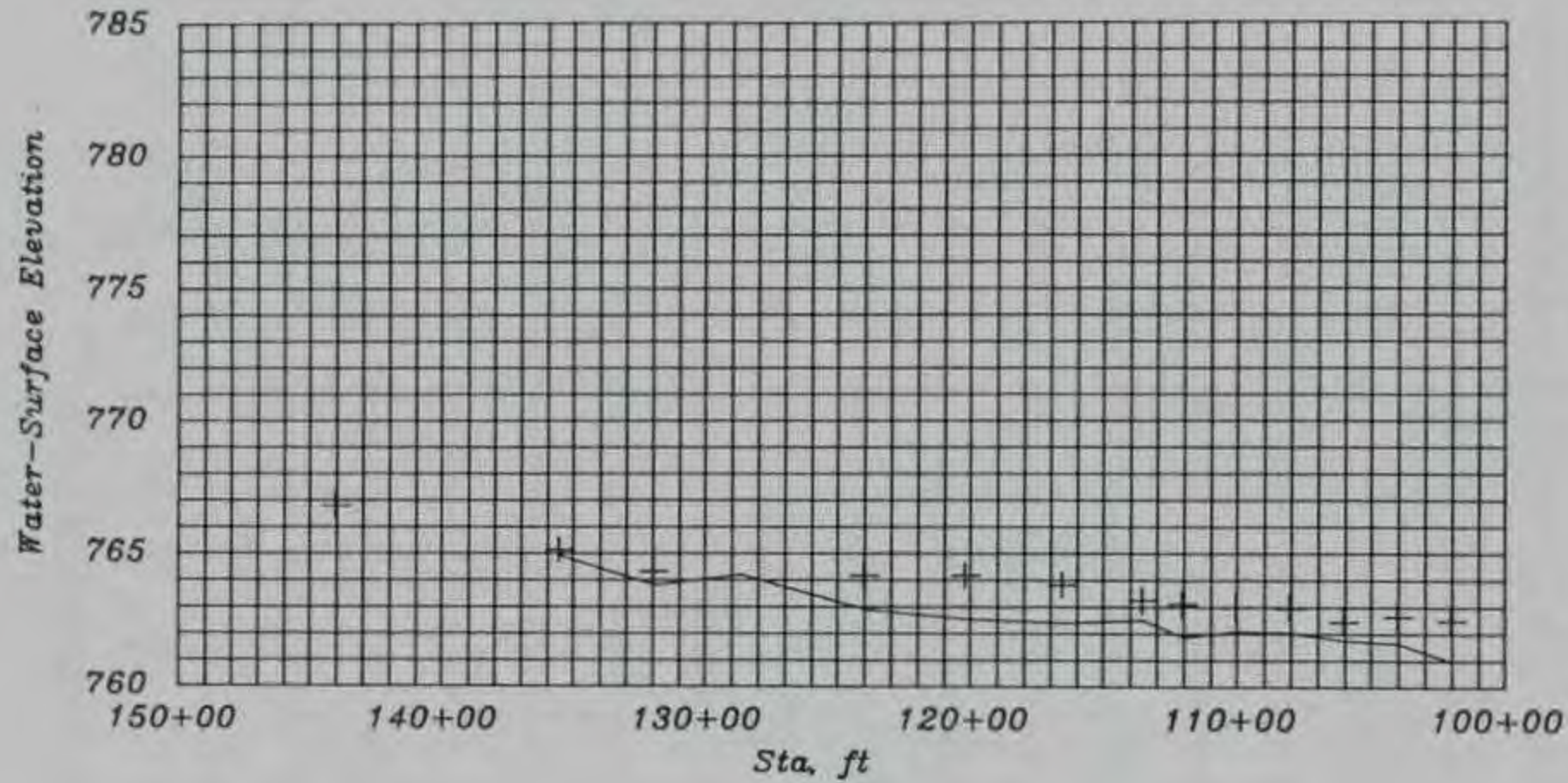

LEGEND
- Baseline
+ Measured

WATER-SURFACE PROFILE
TYPE 21 WEIR
283 CU M/SEC (10,000 CFS)

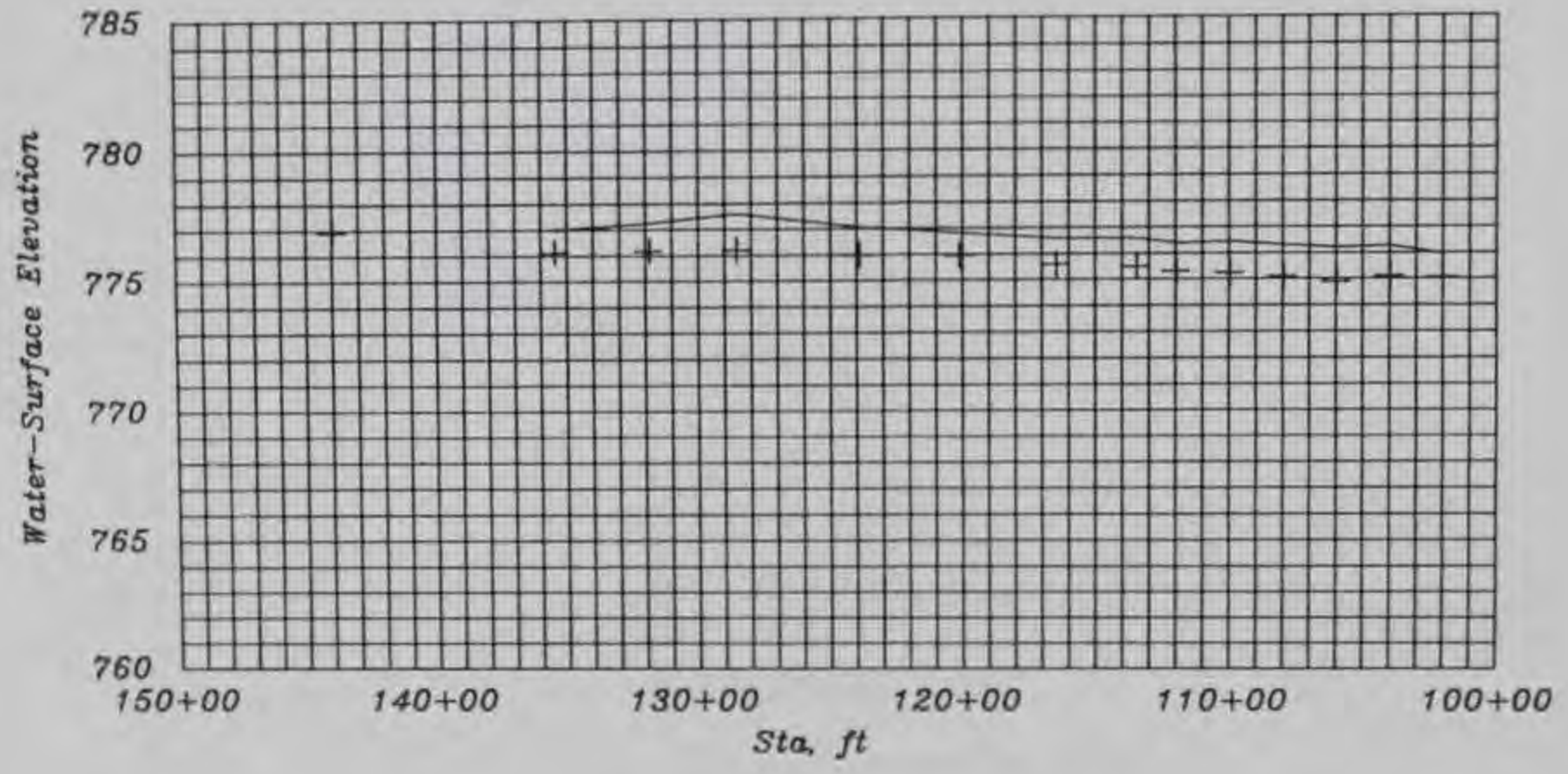

LEGEND
 - Baseline
 + Measured

WATER-SURFACE PROFILE
 TYPE 21 WEIR
 991 CU M/SEC (35,000 CFS)

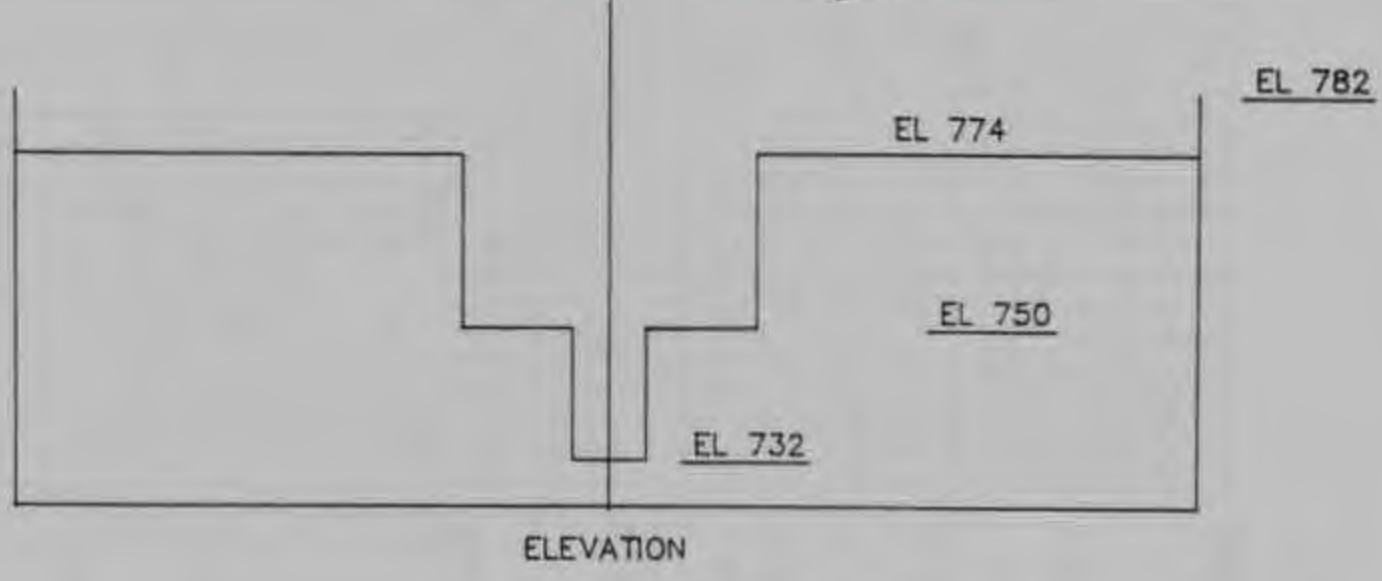
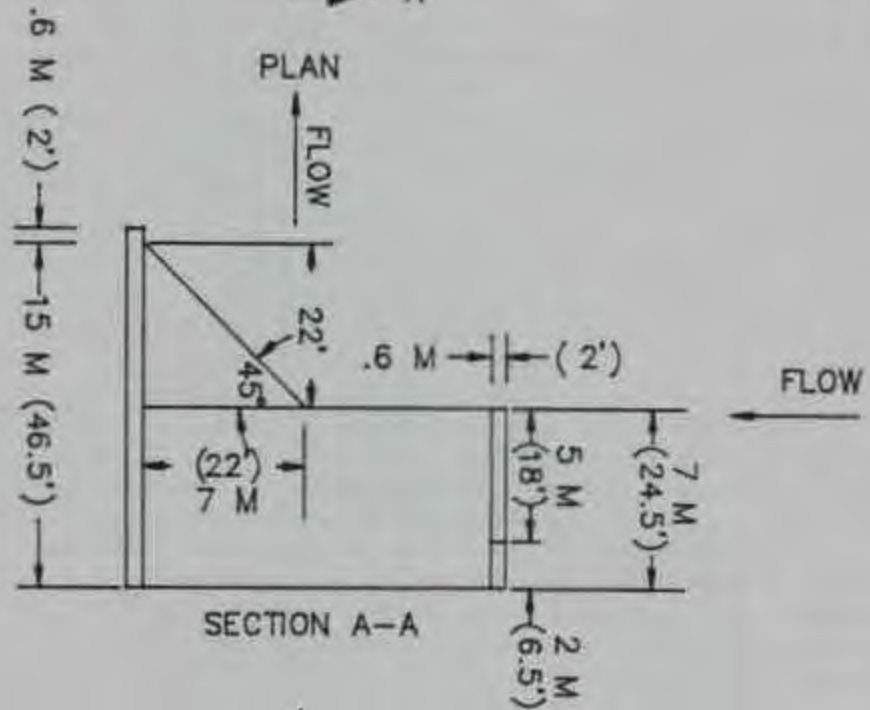
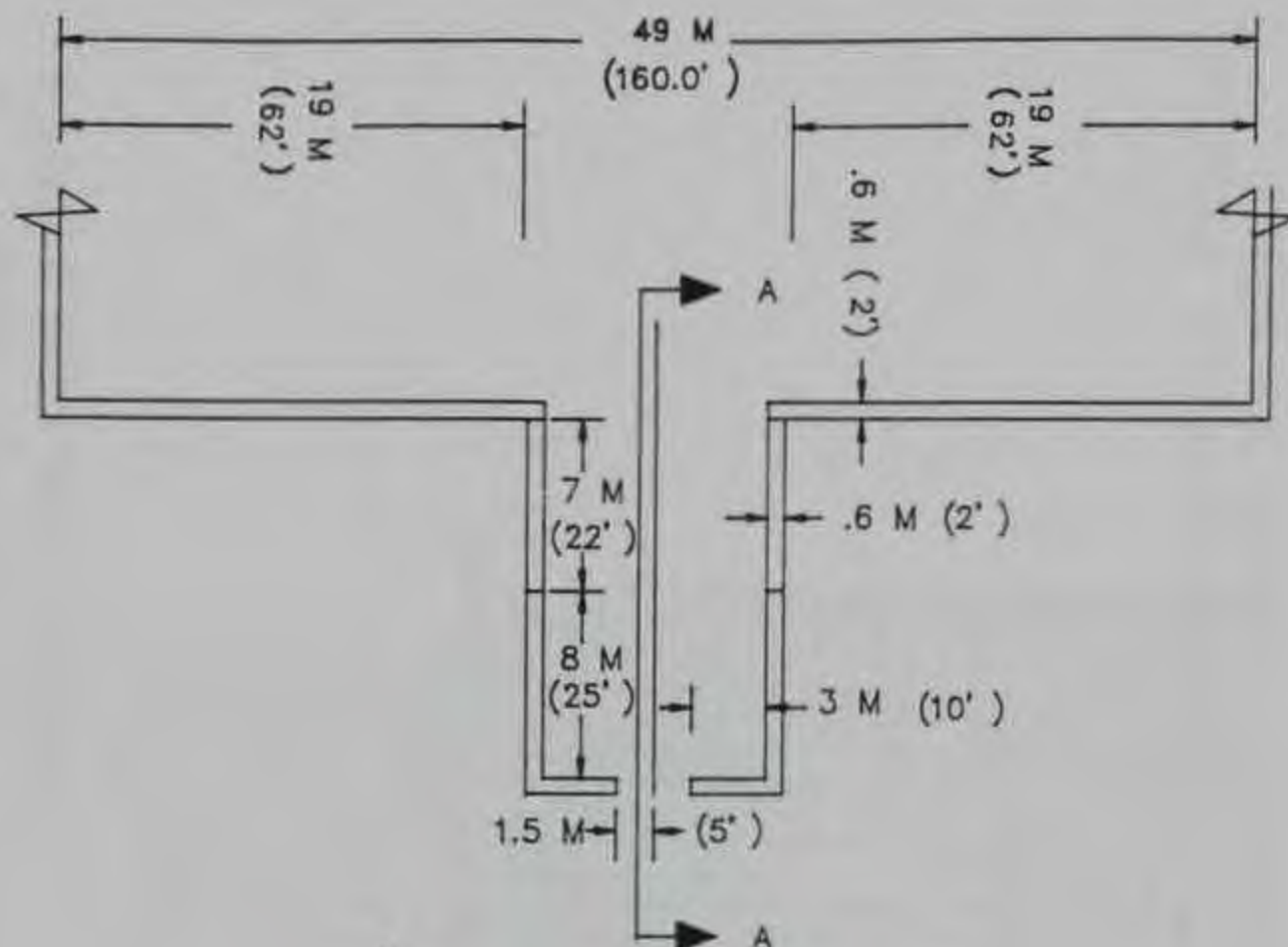

TYPE 22 WEIR DESIGN

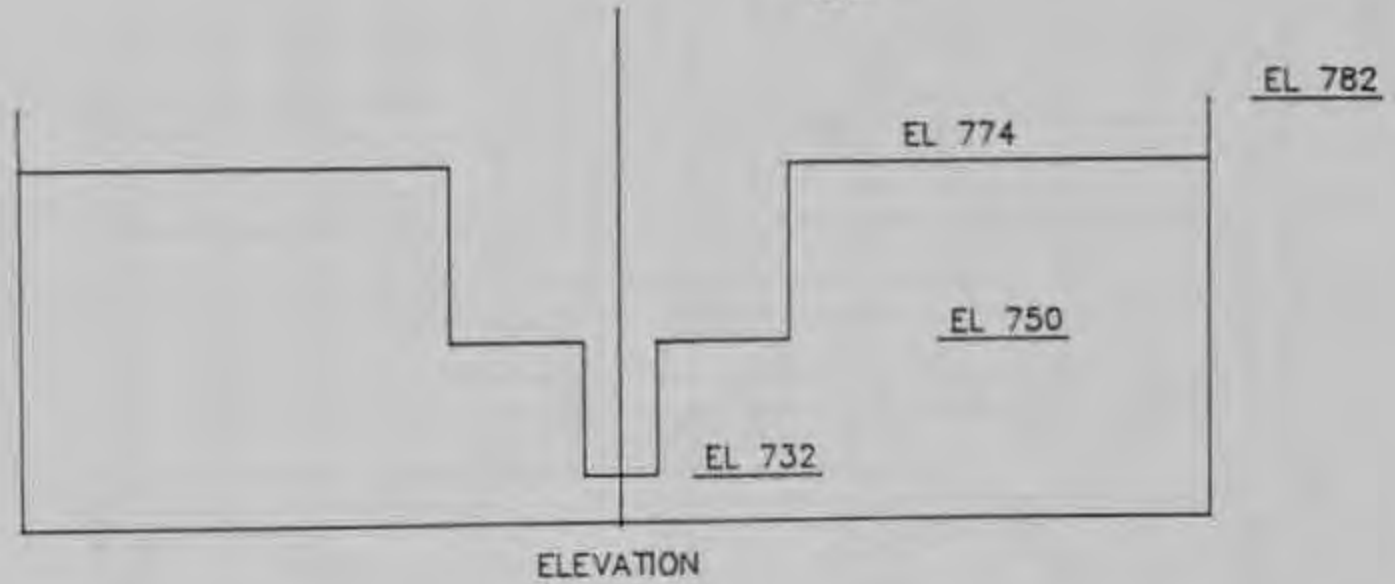
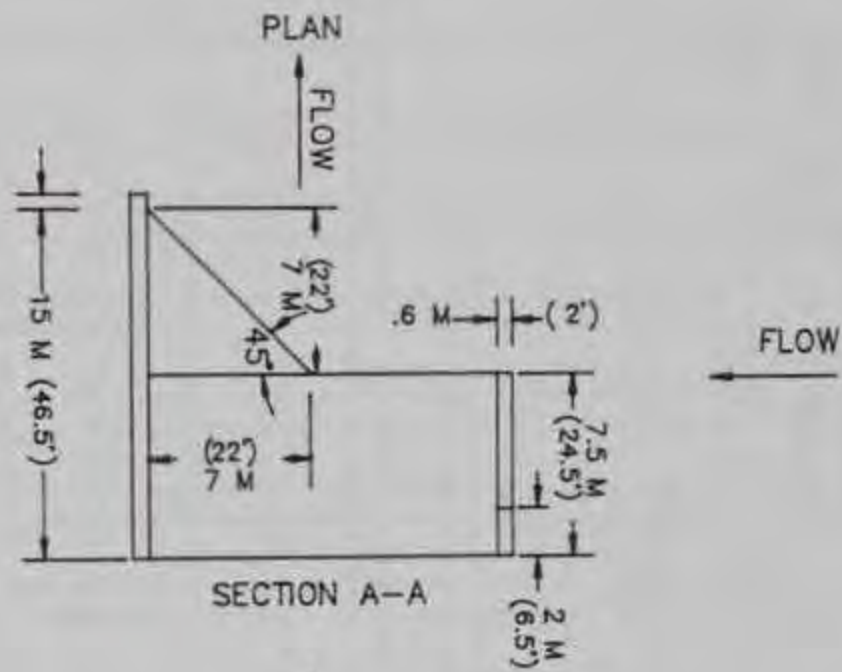
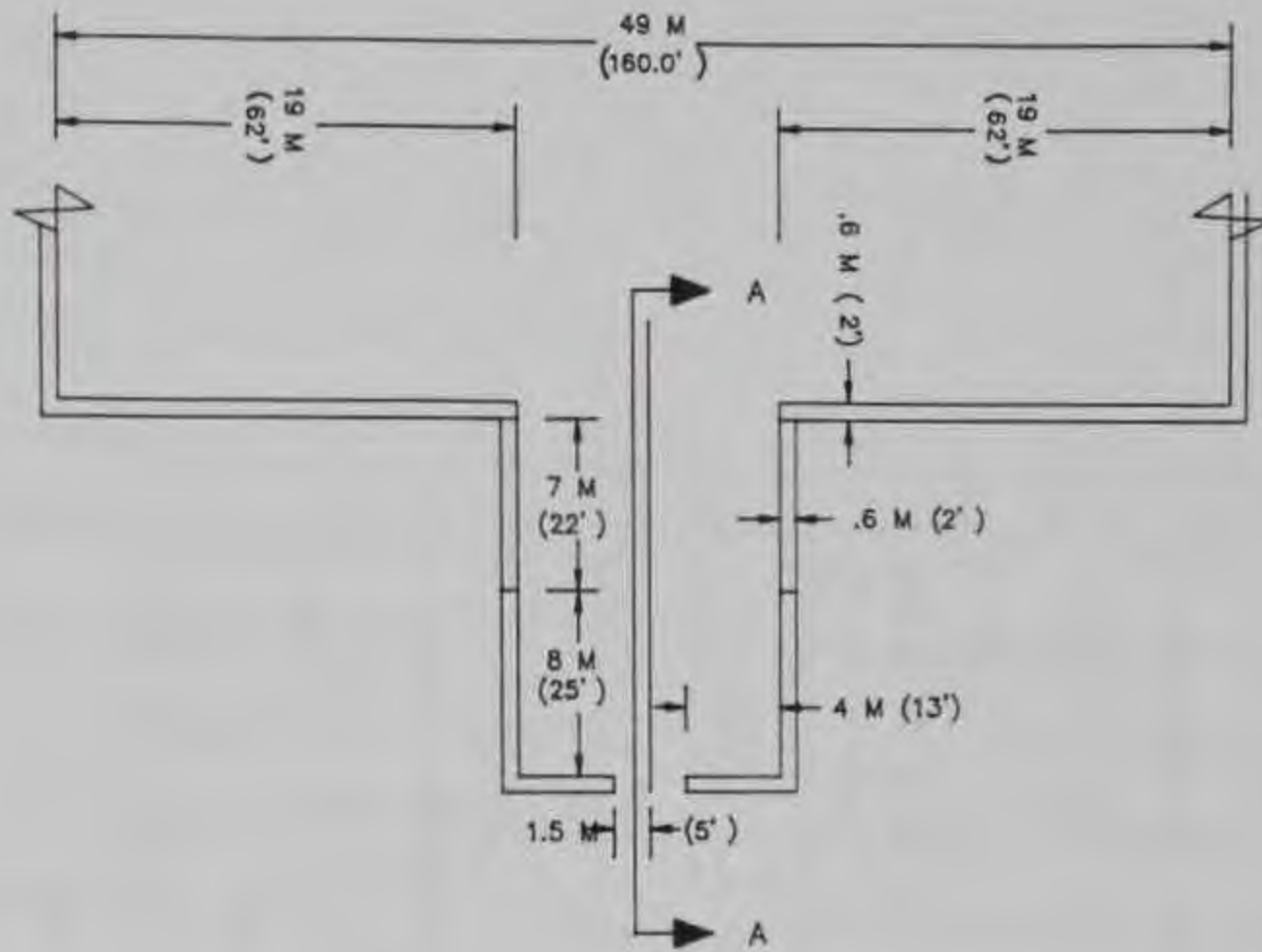

TYPE 23 WEIR DESIGN

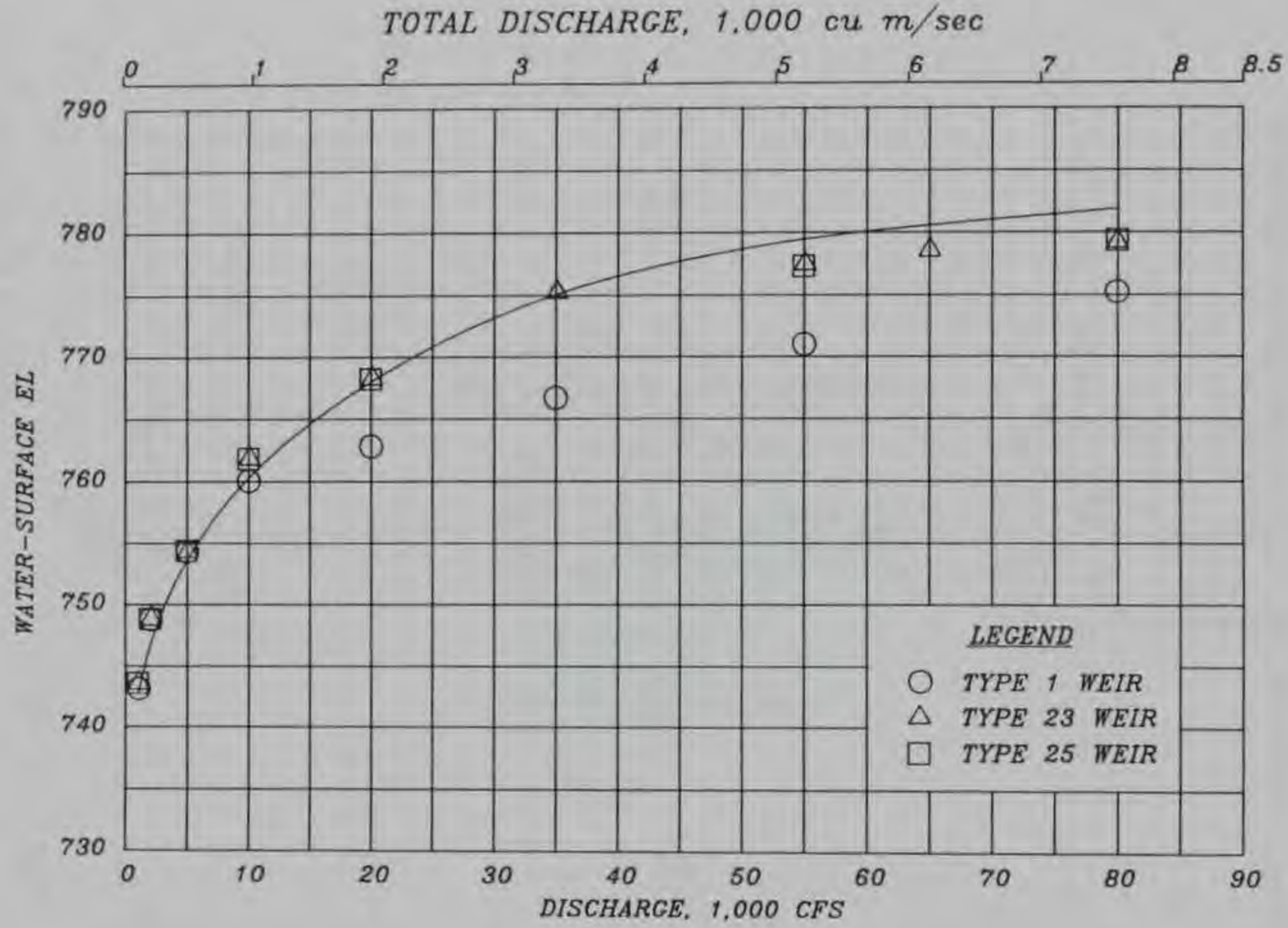

STAGE-DISCHARGE CURVE
STA 102+00

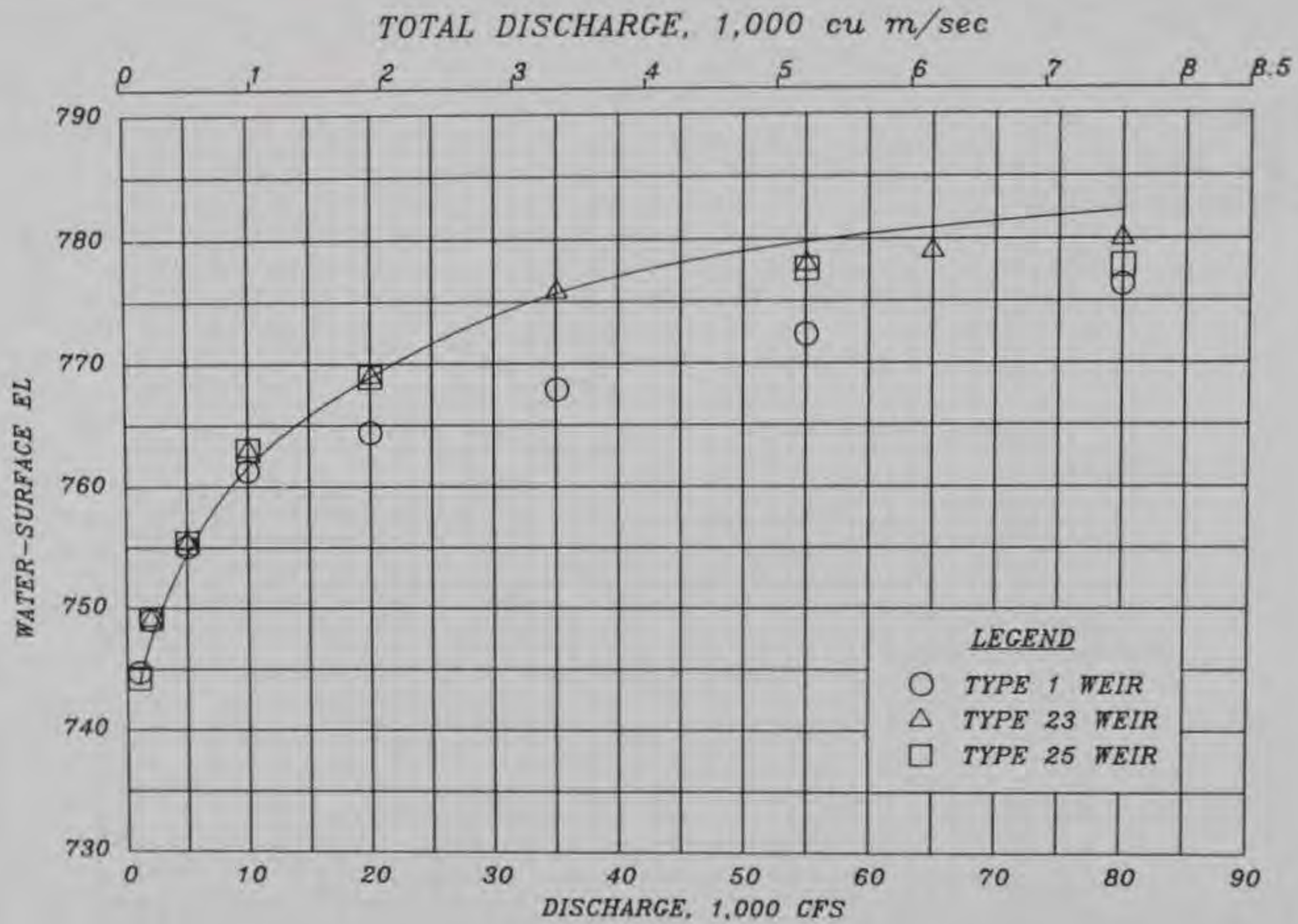

STAGE-DISCHARGE CURVE
STA 113+50

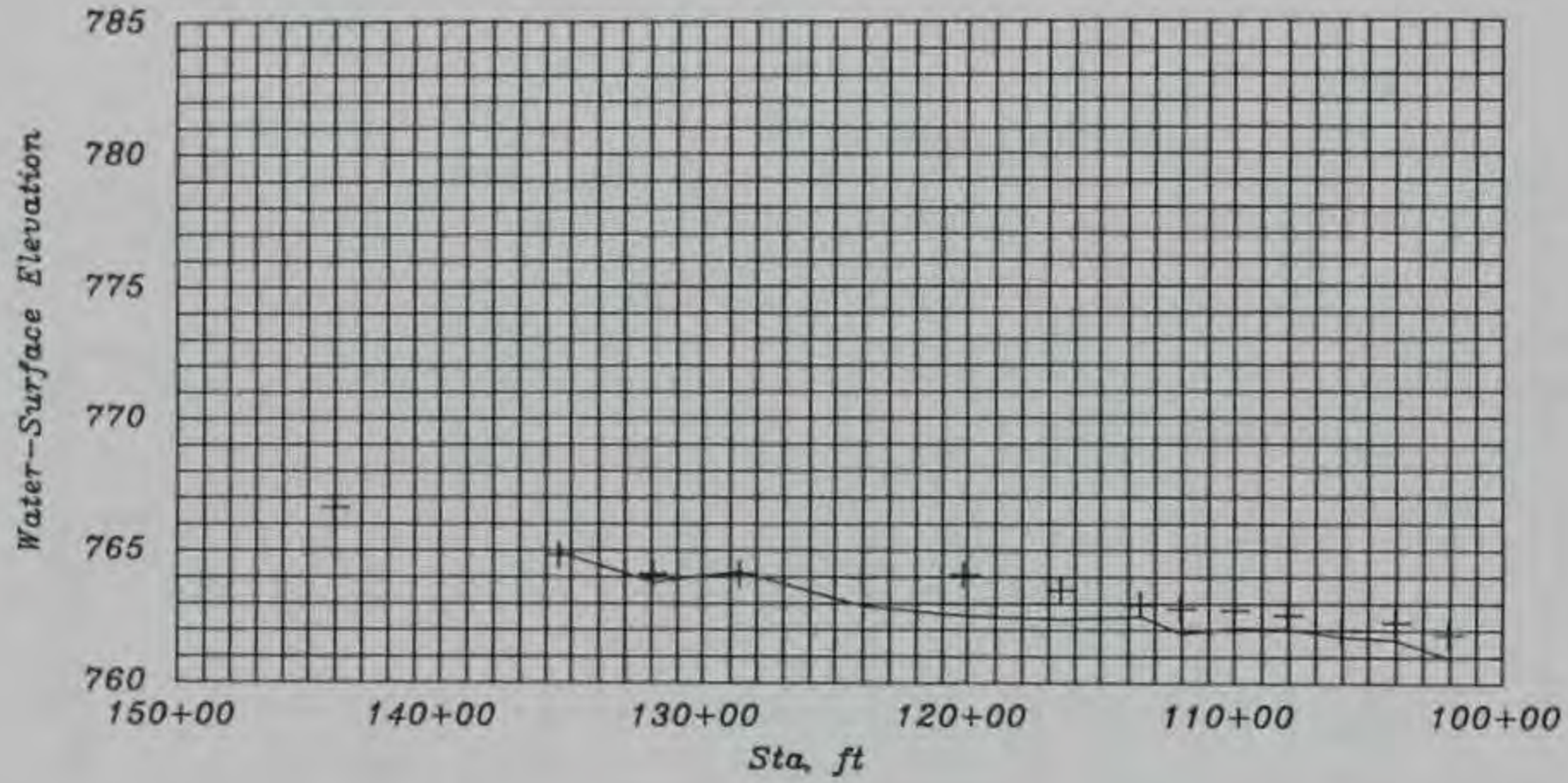

LEGEND
- Baseline
+ Measured

WATER-SURFACE PROFILE
TYPE 23 WEIR
283 CU M/SEC (10,000 CFS)

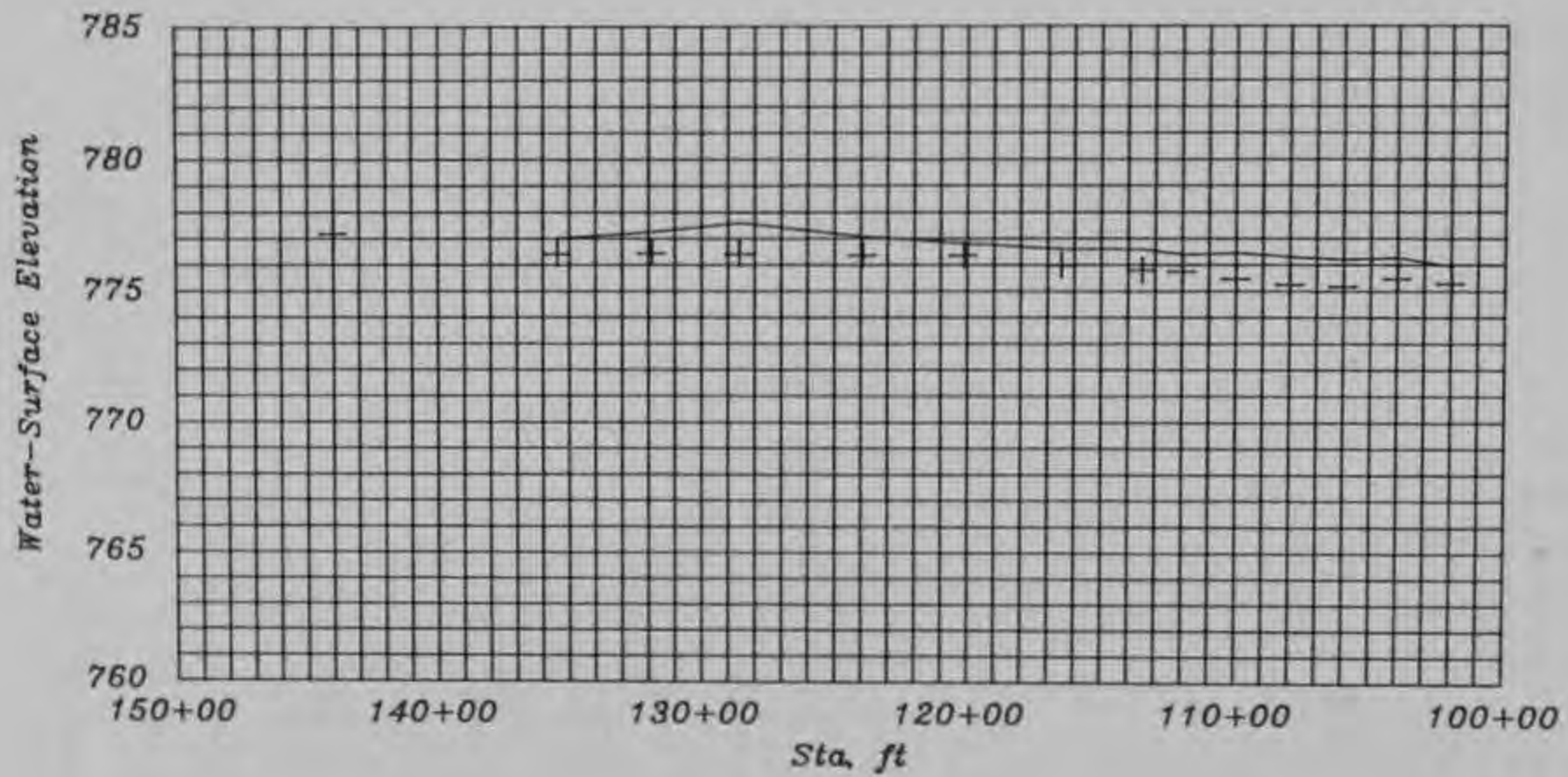

LEGEND
 - Baseline
 + Measured

WATER-SURFACE PROFILE
 TYPE 23 WEIR
 991 CU M/SEC (35,000 CFS)

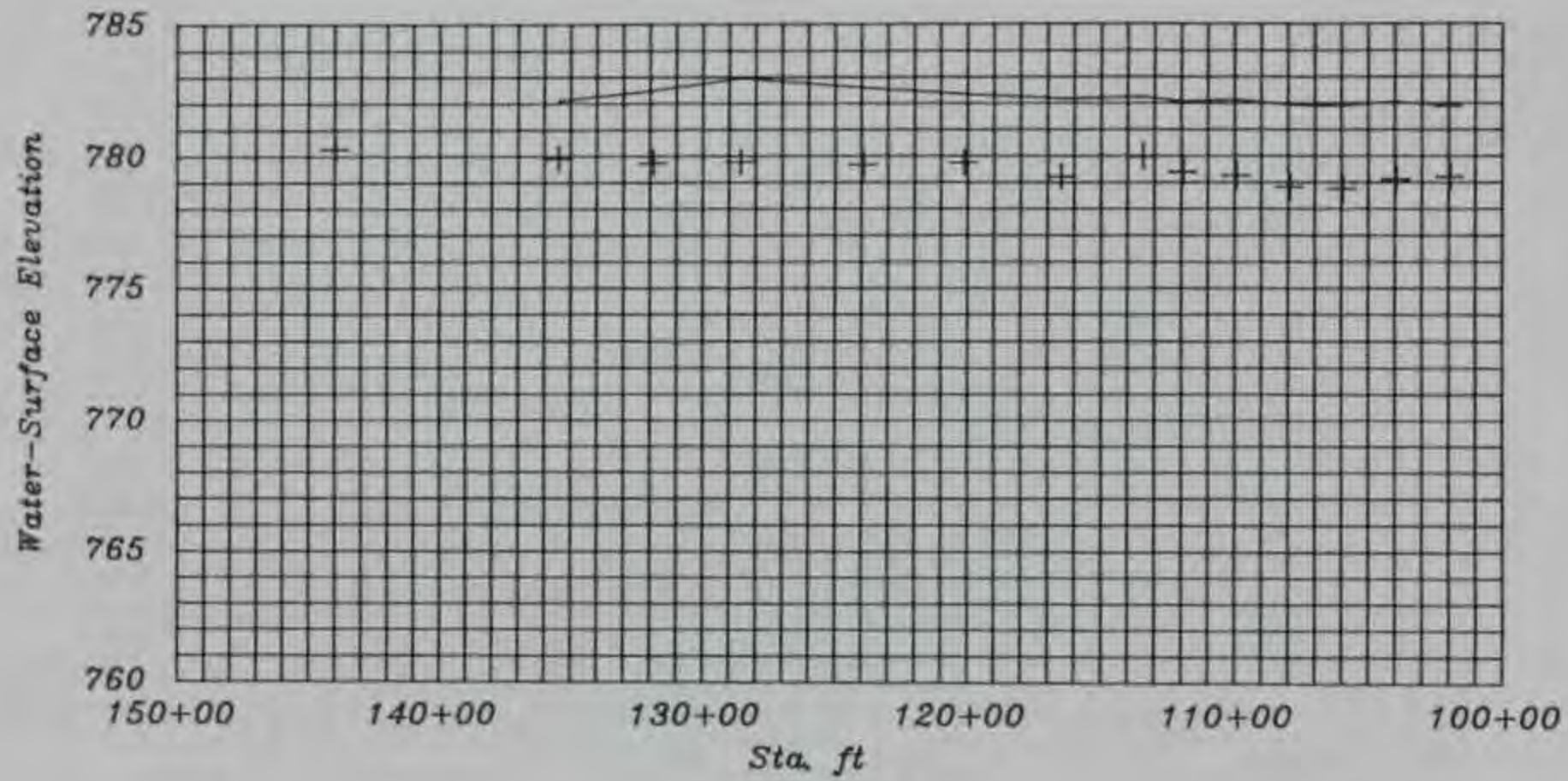

LEGEND
- Baseline
+ Measured

WATER-SURFACE PROFILE
TYPE 23 WEIR
2,265 CU M/SEC (80,000 CFS)

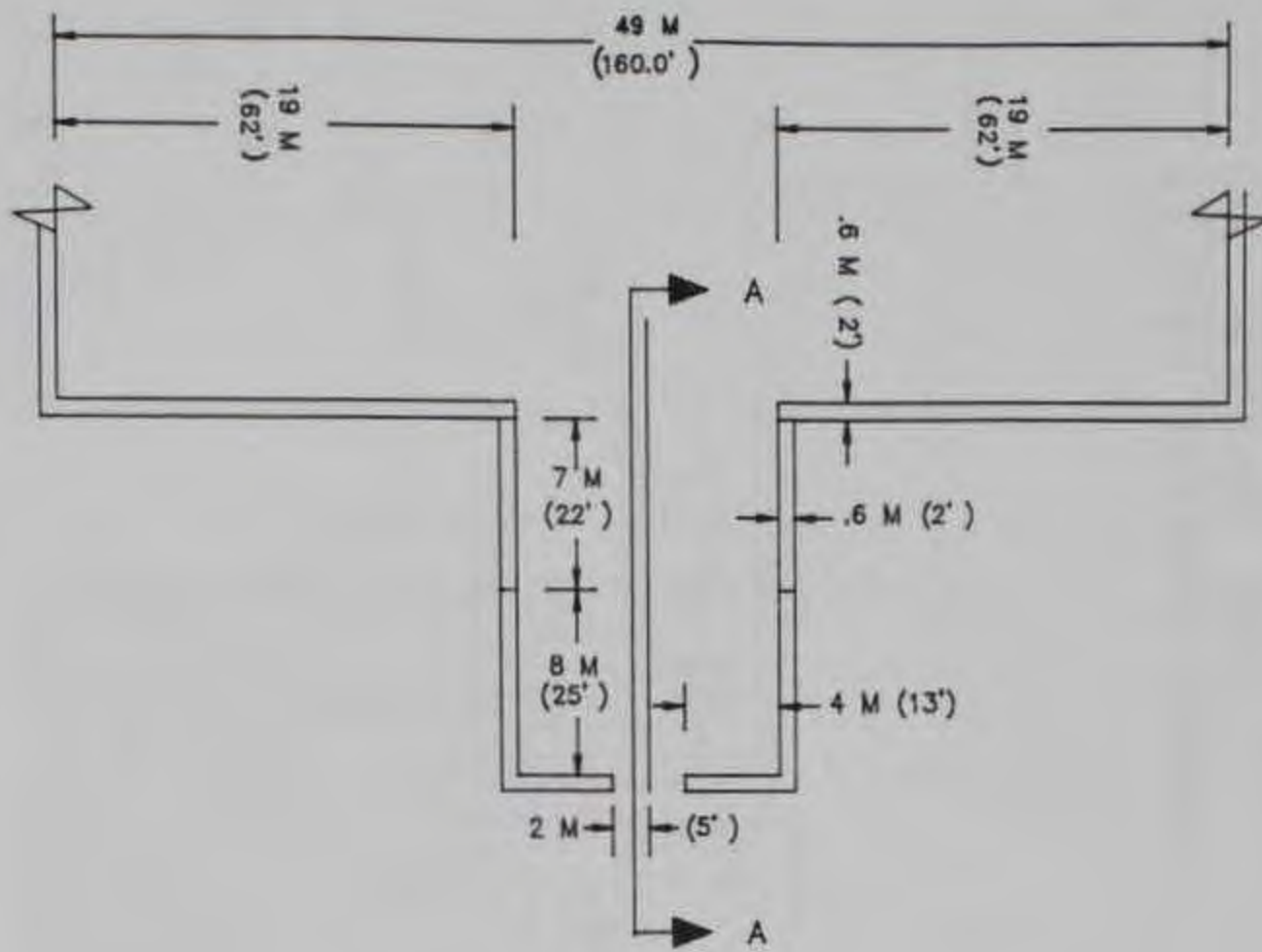

PLAN
FLOW

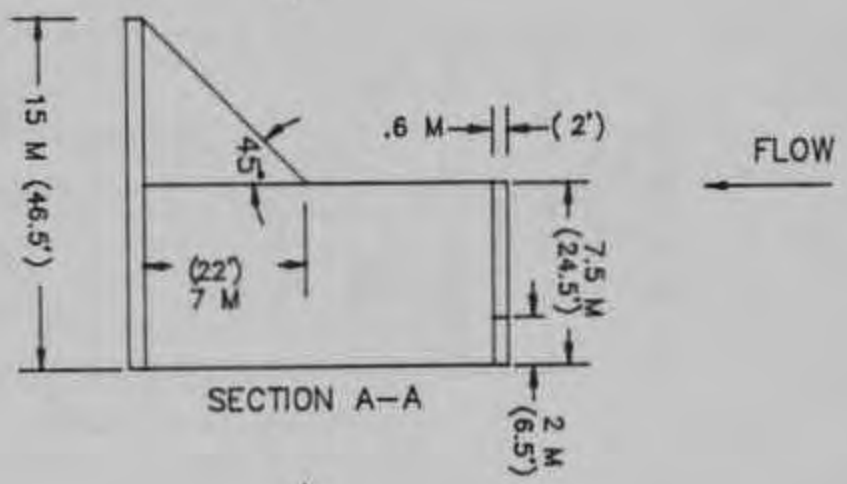

SECTION A-A

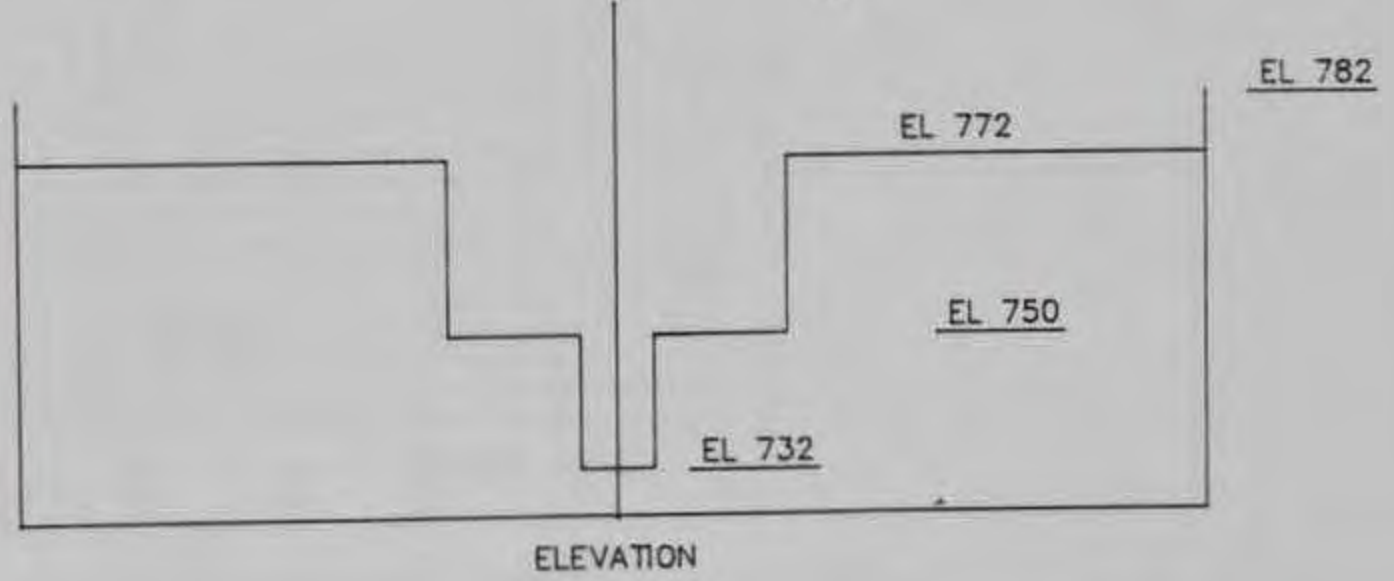

ELEVATION

TYPE 24 WEIR DESIGN

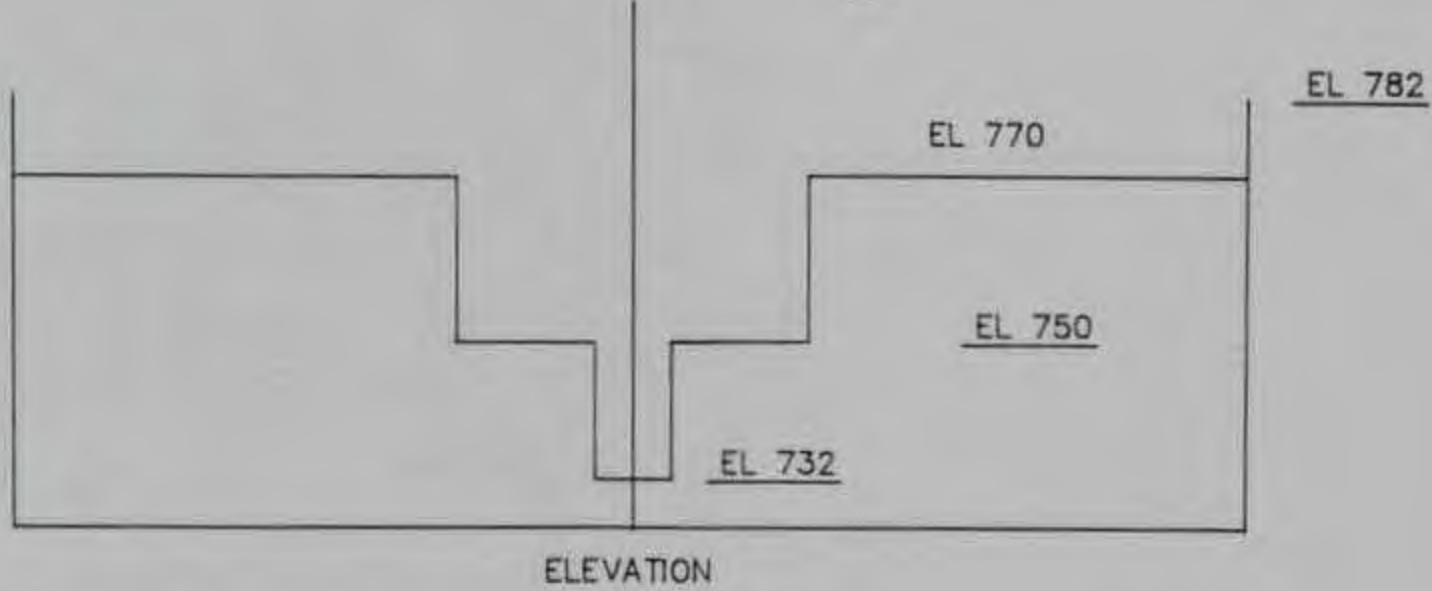
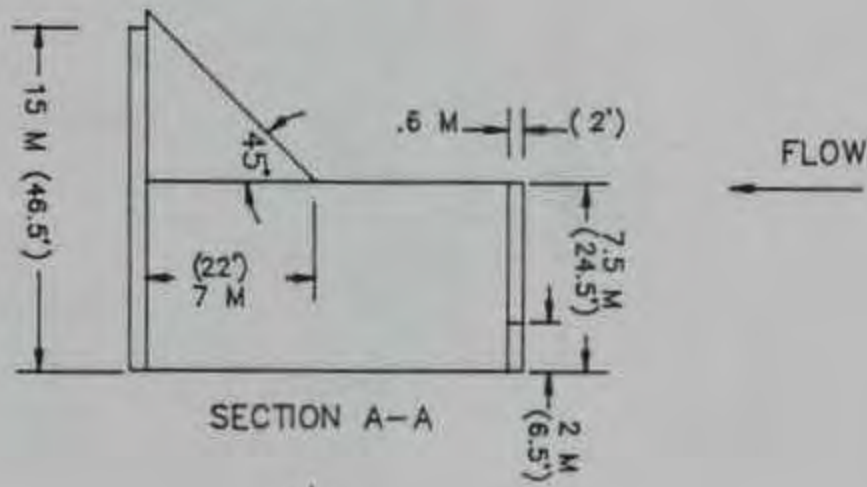
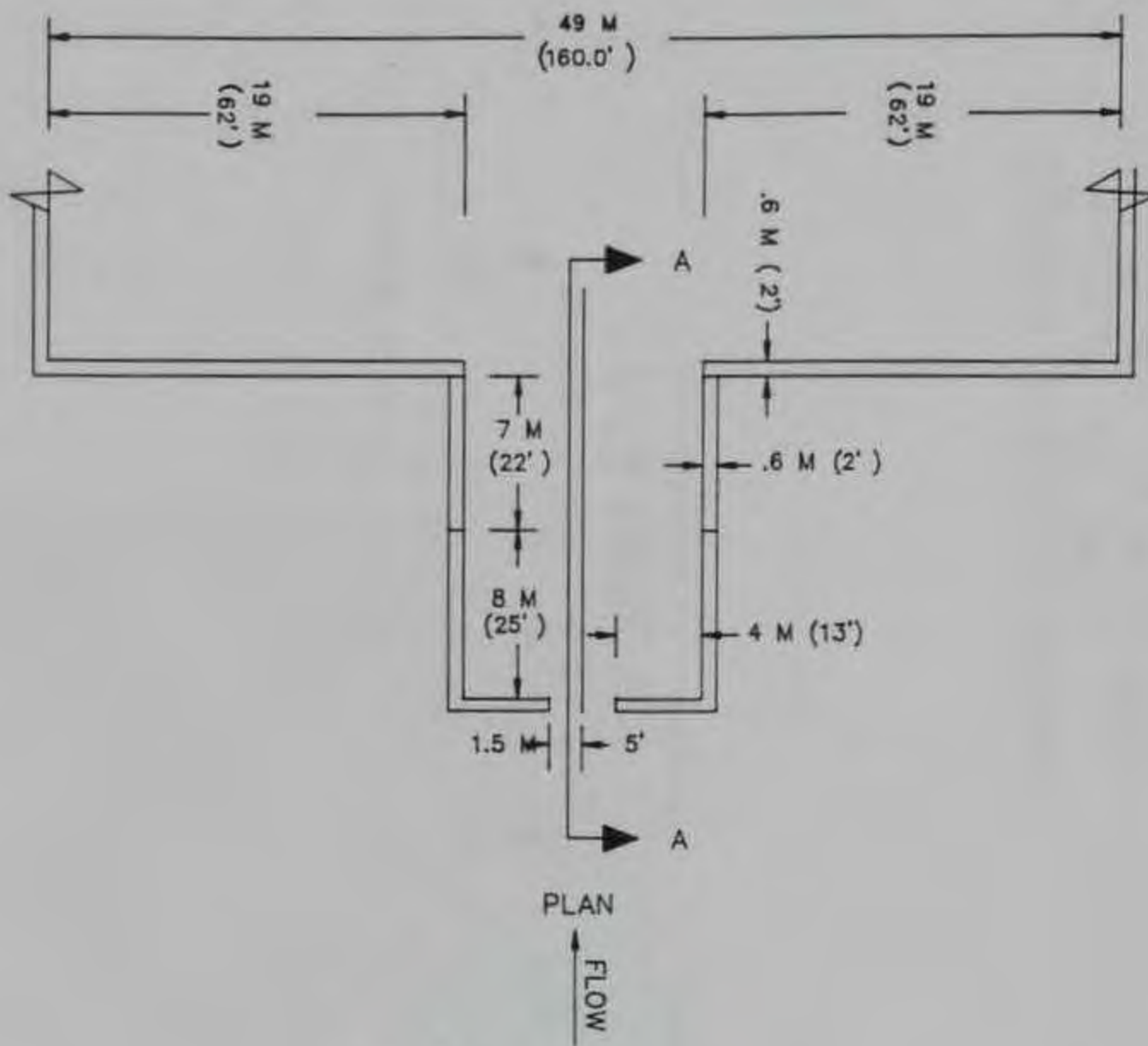

TYPE 25 WEIR DESIGN

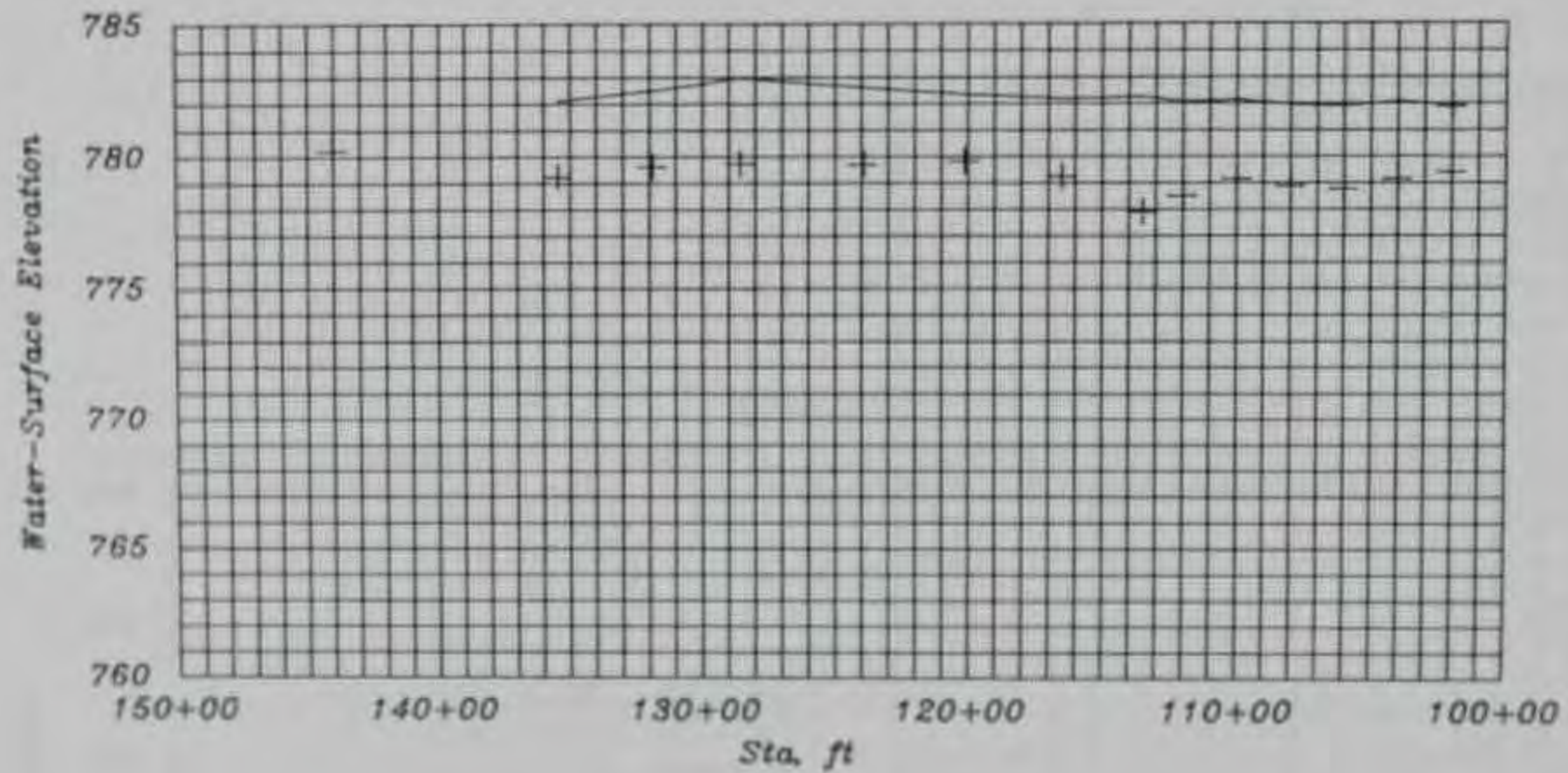

LEGEND
 - Baseline
 + Measured

WATER-SURFACE PROFILE
 TYPE 25 WEIR
 2,265 CU M/SEC (80,000 CFS)

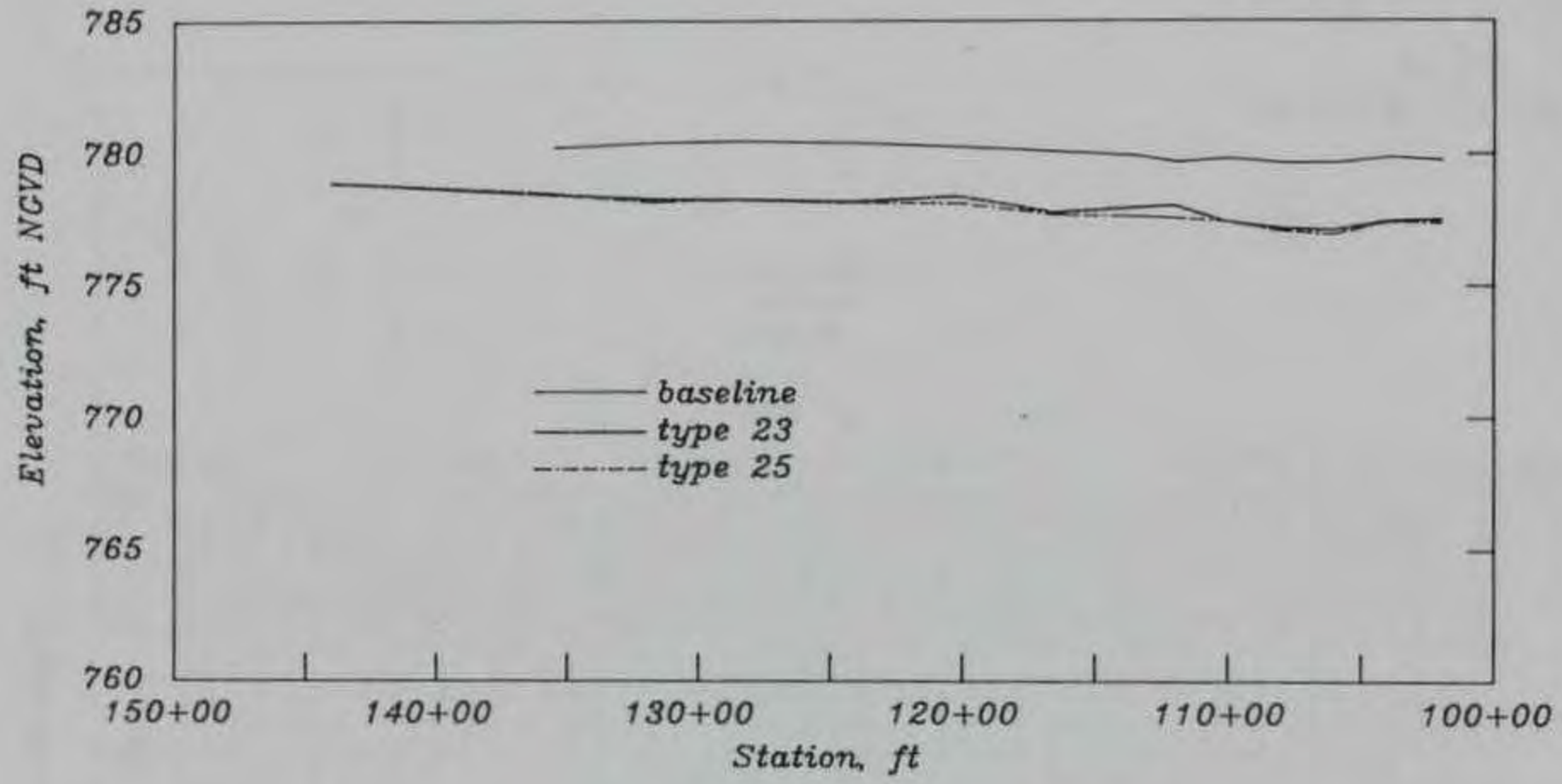

WATER-SURFACE PROFILE
TYPES 23 & 25 WEIRS
1,557 CU M/SEC (55,000 CFS)

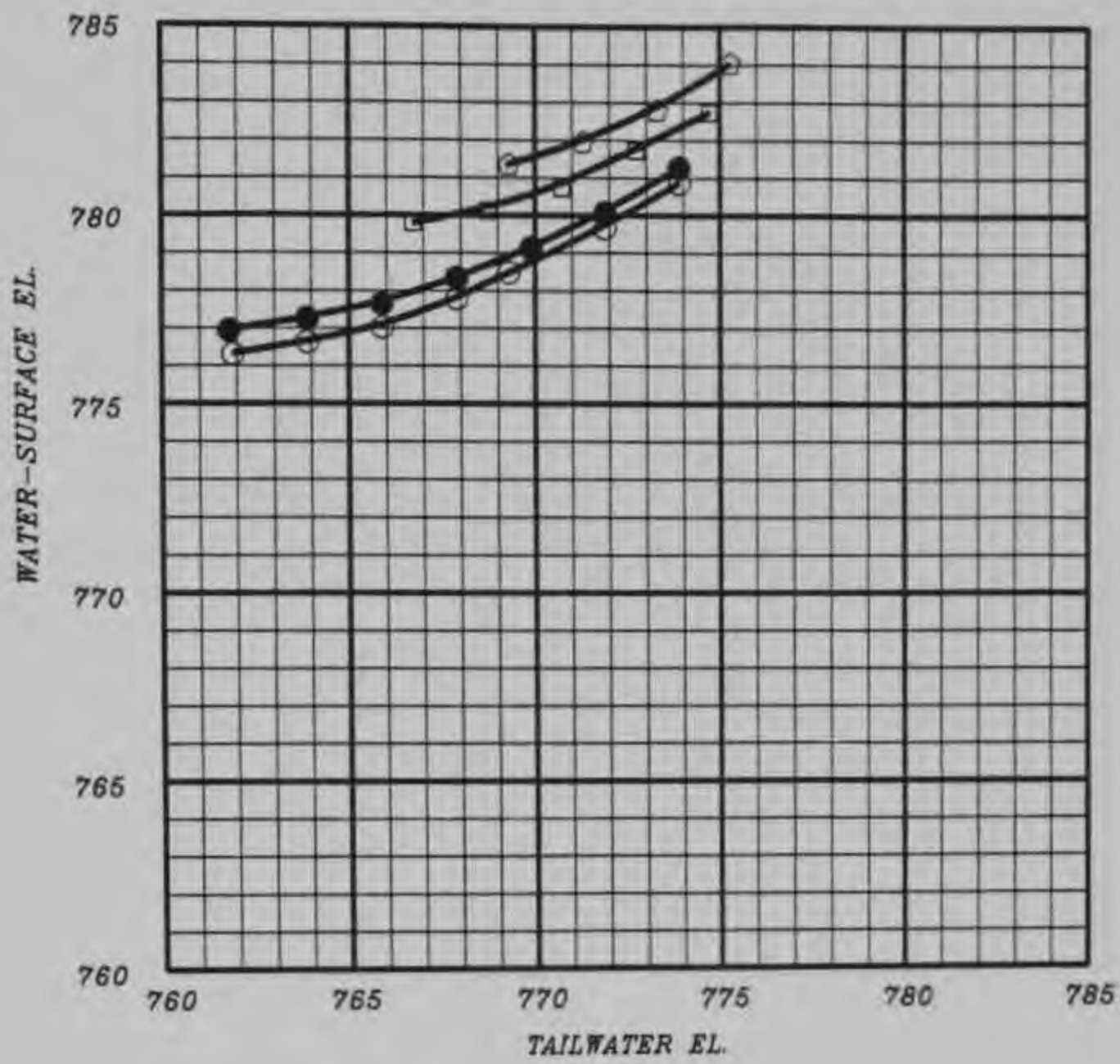

LEGEND

- 991 cu m/sec (35,000 CFS)
- 1,132 cu m/sec (40,000 CFS)
- 1,557 cu m/sec (55,000 CFS)
- ◇ 1,840 cu m/sec (65,000 CFS)

TYPE 23 WEIR
CALIBRATION
STA 102+00

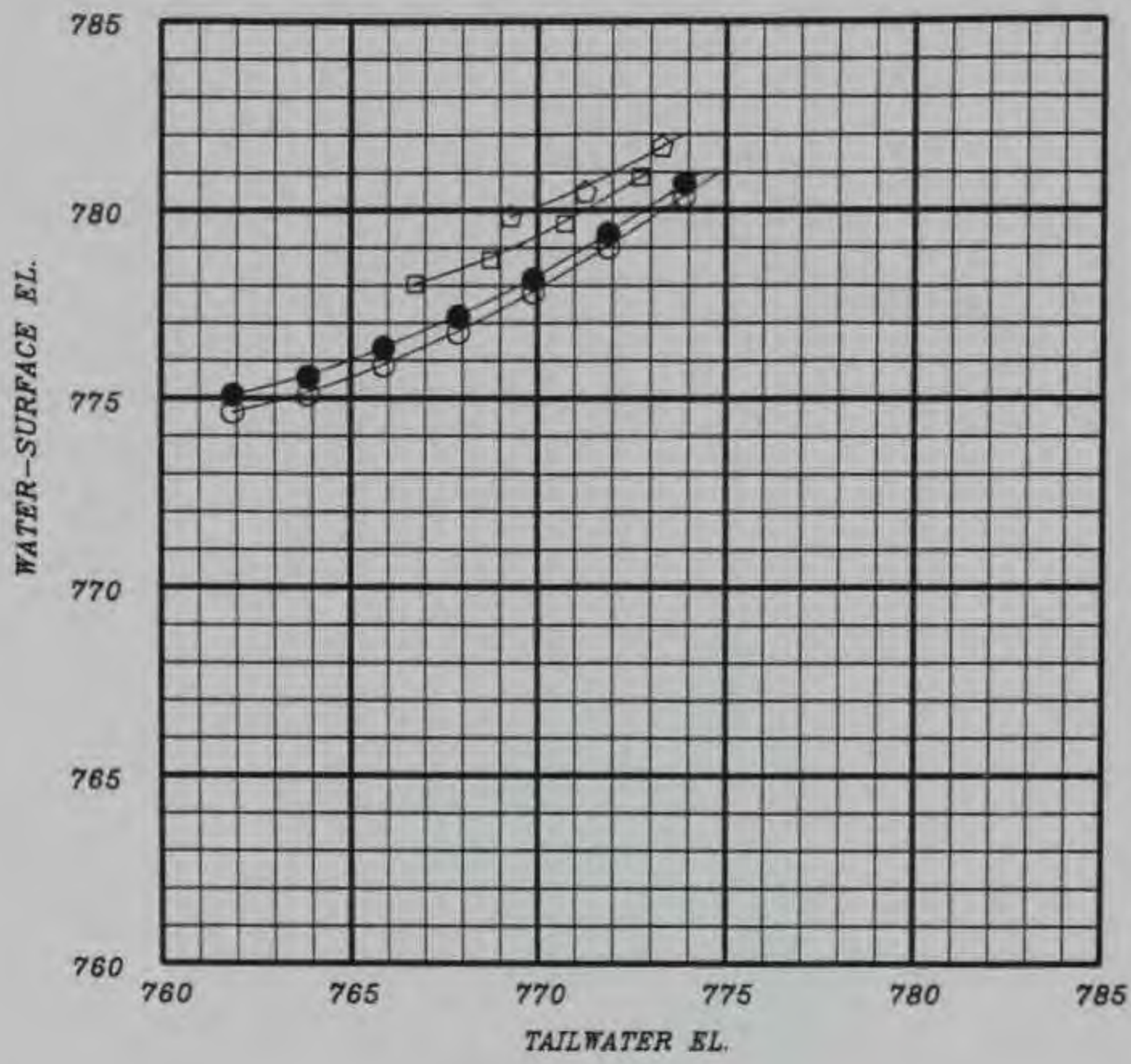

LEGEND

- 991 cu m/sec (35,000 CFS)
- 1,132 cu m/sec (40,000 CFS)
- 1,557 cu m/sec (55,000 CFS)
- ◇ 1,840 cu m/sec (65,000 CFS)

TYPE 25 WEIR
 CALIBRATION
 STA 102+00

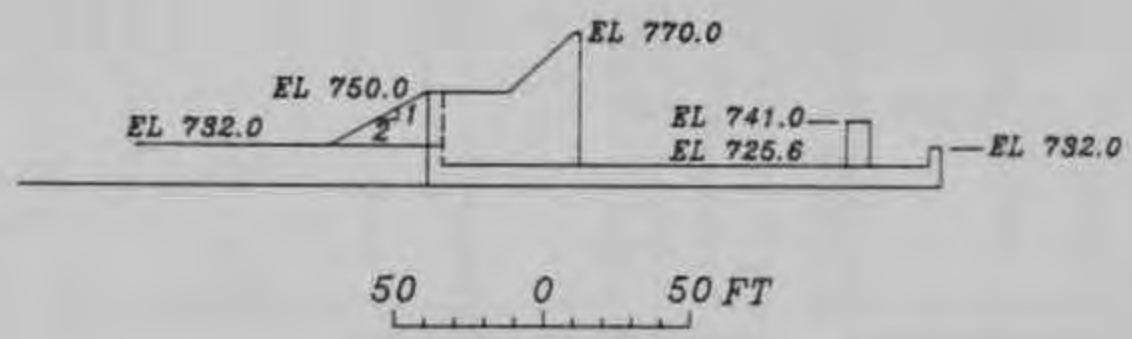
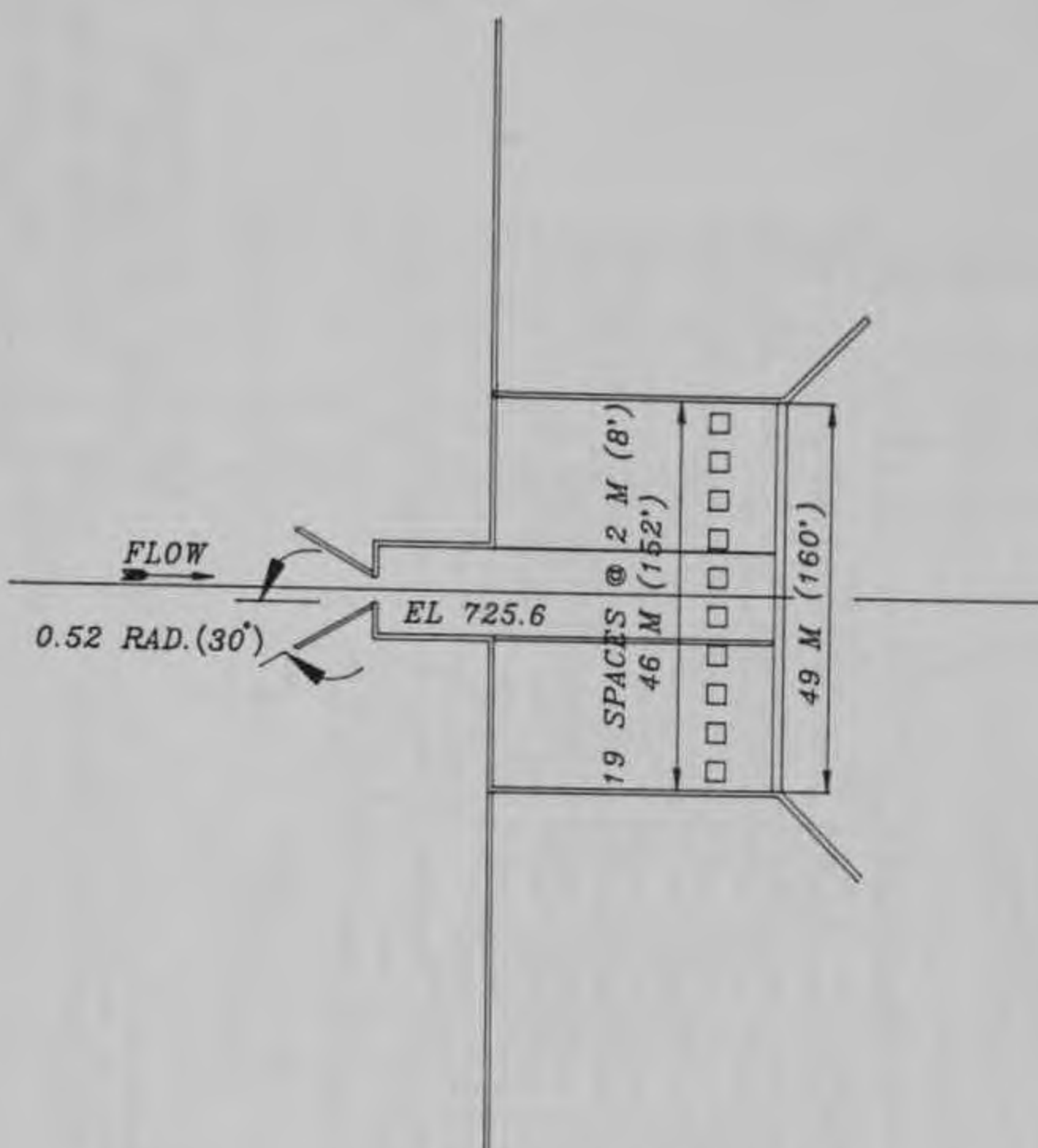

TYPE 1
 STILLING BASIN
 TYPE 2
 DEBRIS DEFLECTOR
 TYPE 25 WEIR

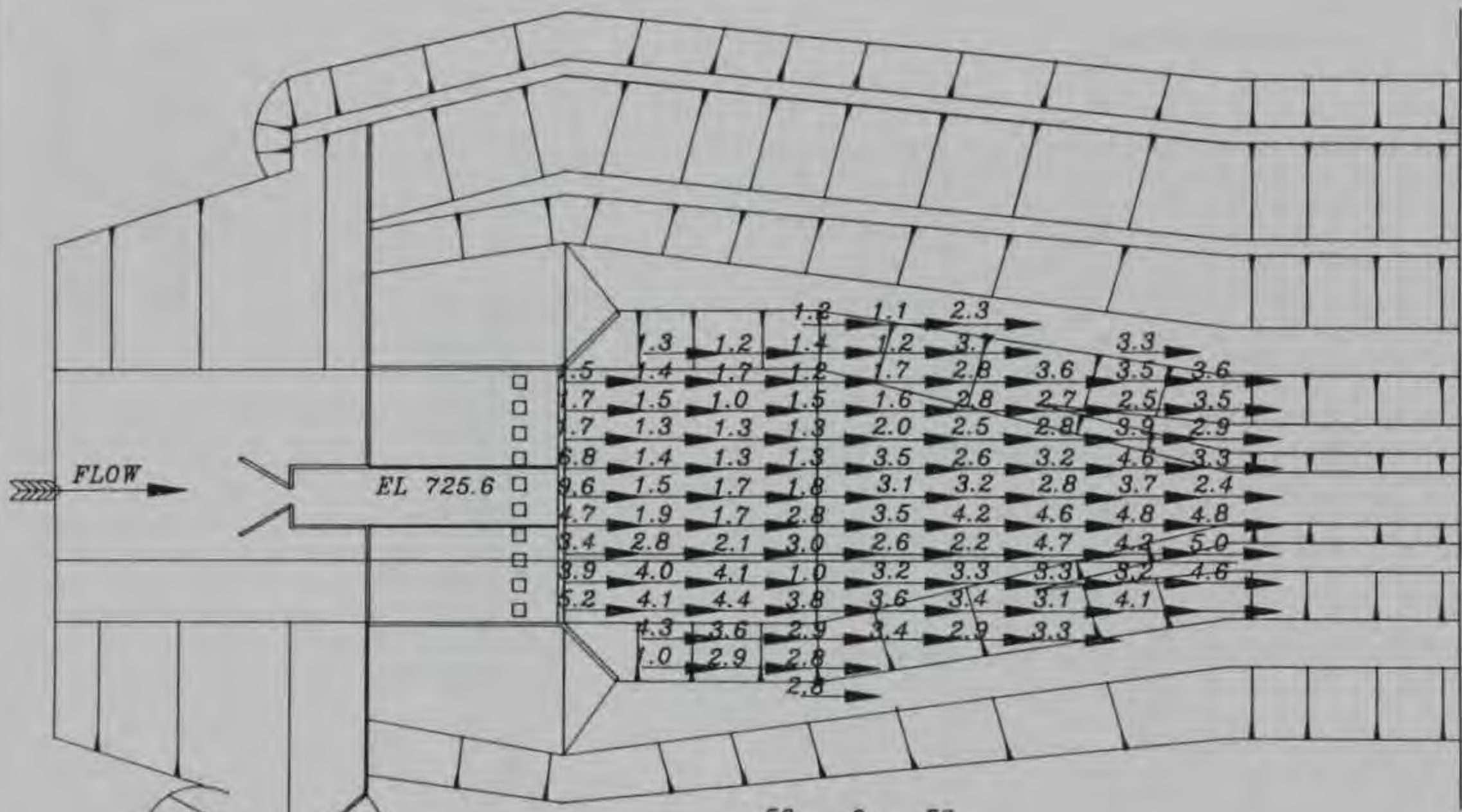

50 0 50
SCALE IN FEET

Note: Velocities measured 2 ft above invert and are given in feet per second. To convert to meters per second, multiply by 0.3048.

BOTTOM VELOCITIES
TYPE 25 WEIR
TYPE 1 STILLING BASIN
 DISCHARGE 991 CU M/SEC (35,000 CFS)
 TAILWATER EL 759.71

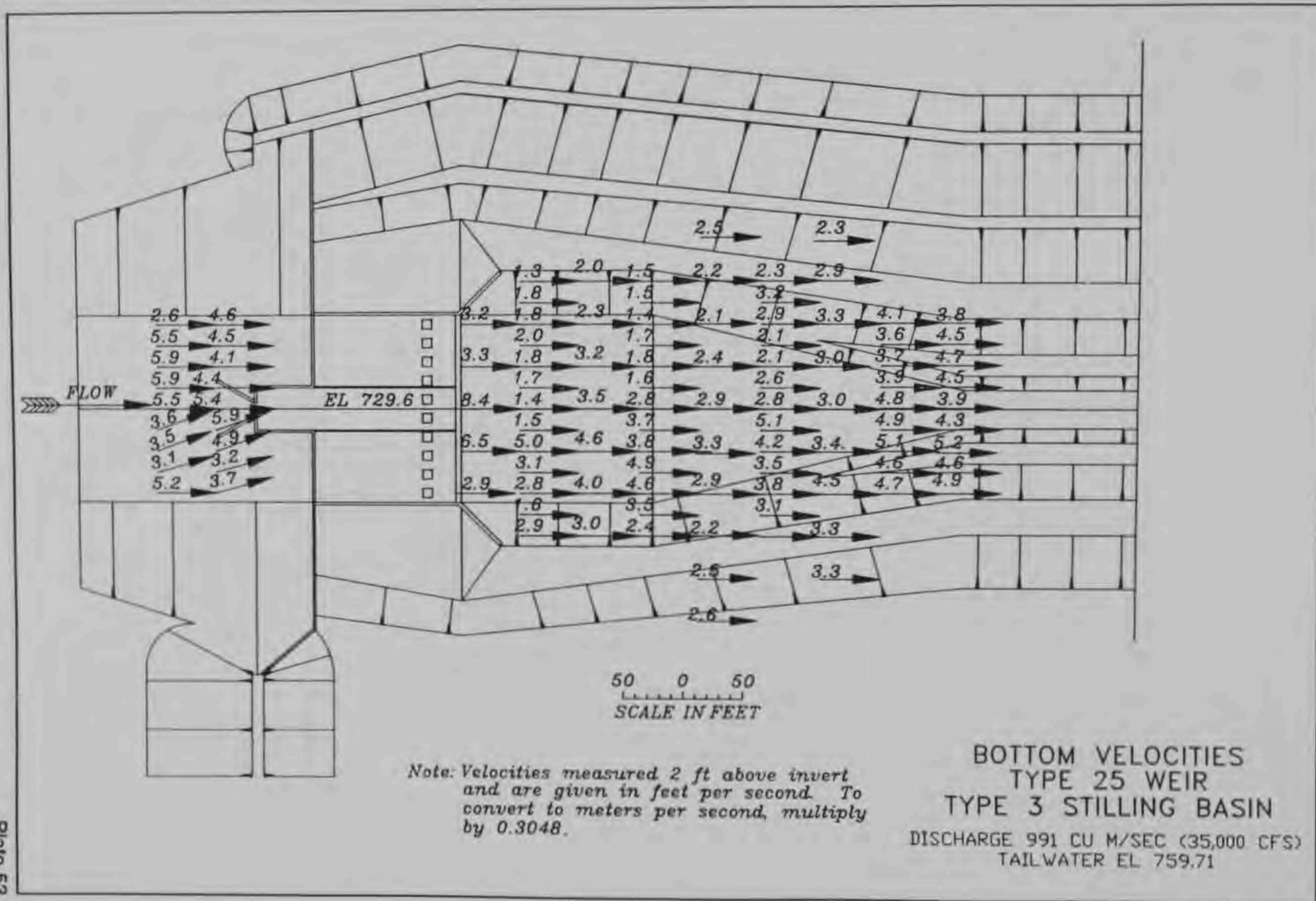

FLOW

EL 729.6

50 0 50
SCALE IN FEET

Note: Velocities measured 2 ft above invert and are given in feet per second. To convert to meters per second, multiply by 0.3048.

BOTTOM VELOCITIES
TYPE 25 WEIR
TYPE 3 STILLING BASIN
DISCHARGE 991 CU M/SEC (35,000 CFS)
TAILWATER EL 759.71

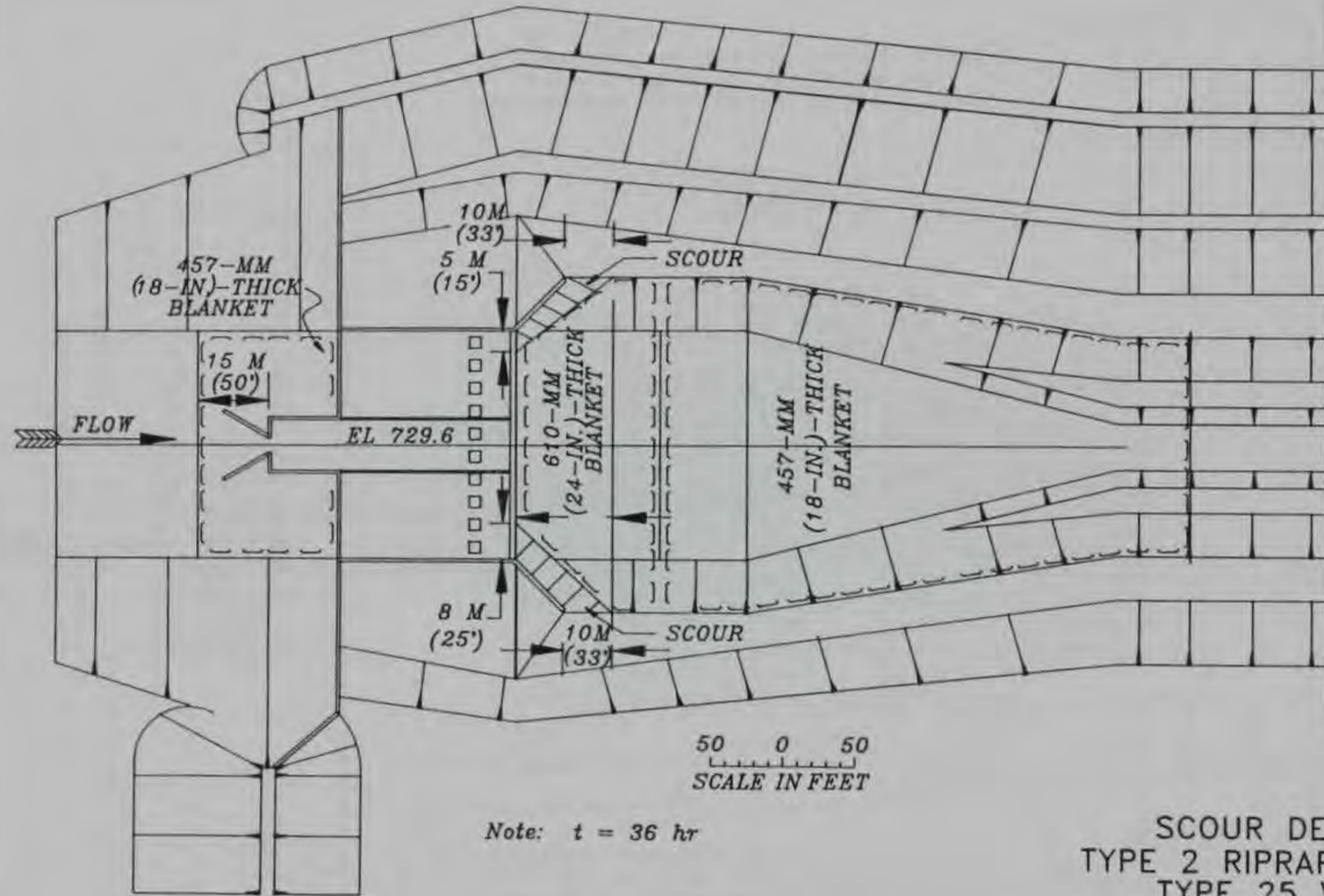

Note: $t = 36 \text{ hr}$

SCOUR DETAIL
TYPE 2 RIPRAP DESIGN
TYPE 25 WEIR
TYPE 3 STILLING BASIN
DISCHARGE 991 CU M/SEC (35,000 CFS)
TAILWATER EL 759.71

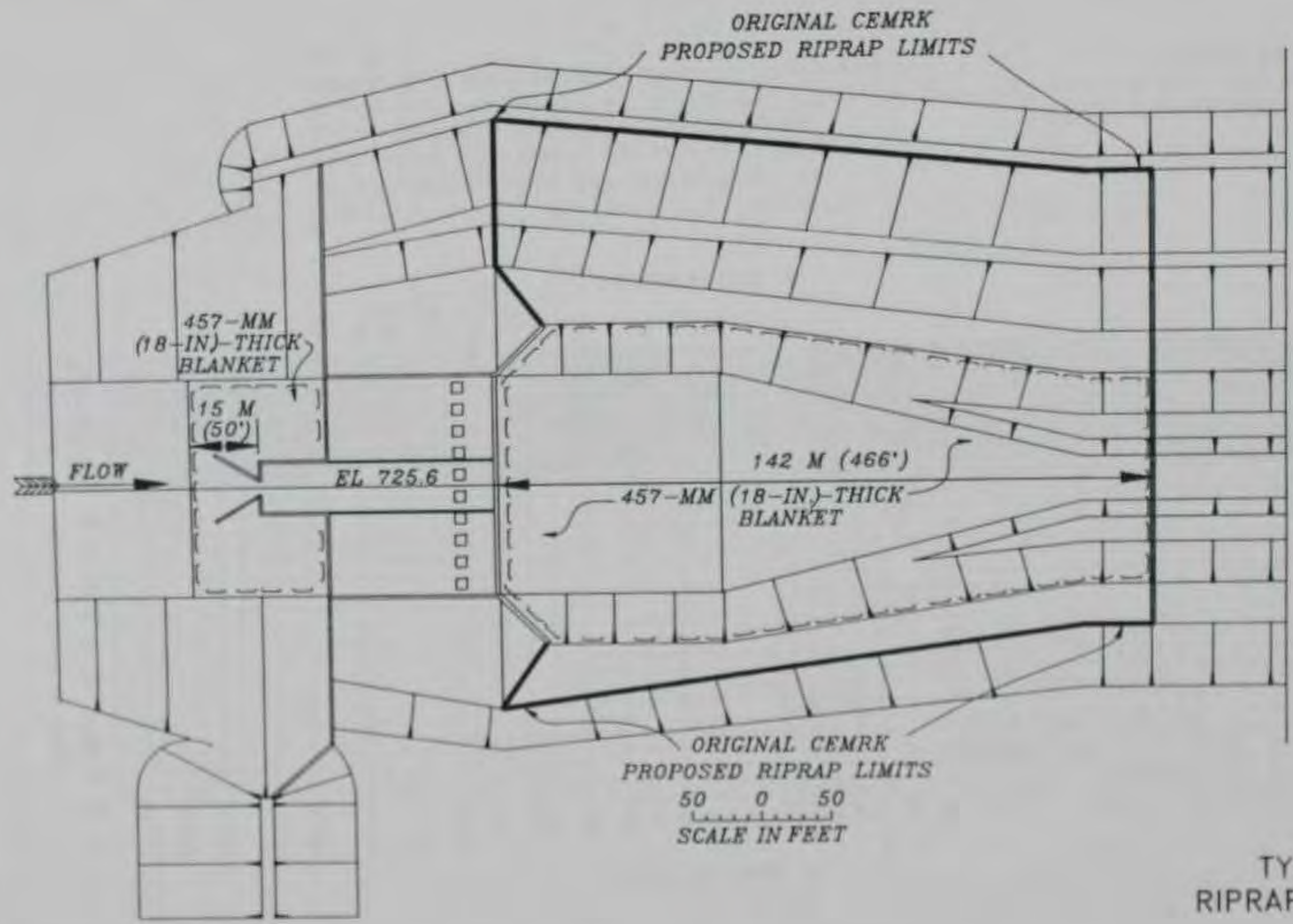

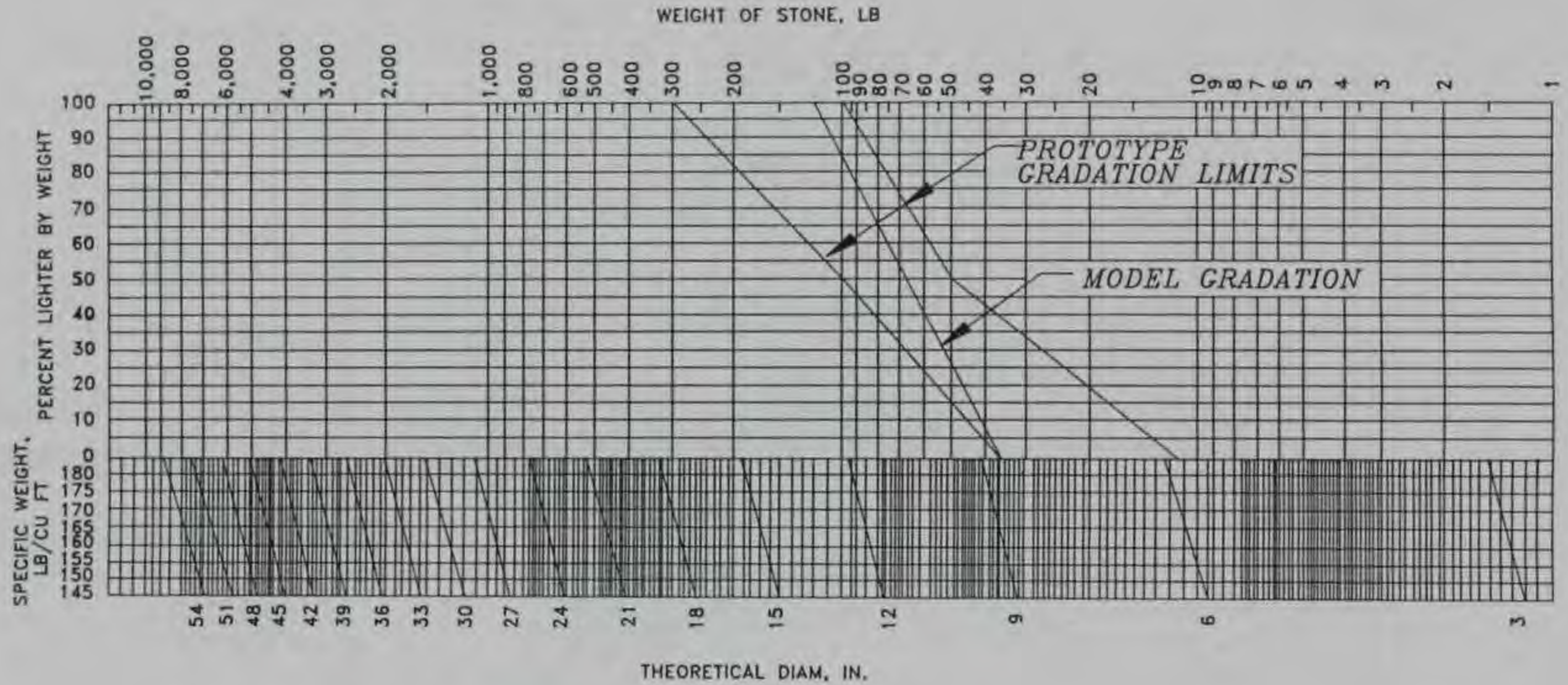

Note: Specific weight of stone 165 lb/cu ft.
 To convert pounds per cubic foot to kilograms per cubic meter, multiply by 16.01846. To convert pounds to kilograms, multiply by 0.453924. To convert inches to millimeters, multiply by 25.4.

RIPRAP GRADATION CURVES
 457-MM-(18-IN.-)THICK BLANKET
 (CLASS A)

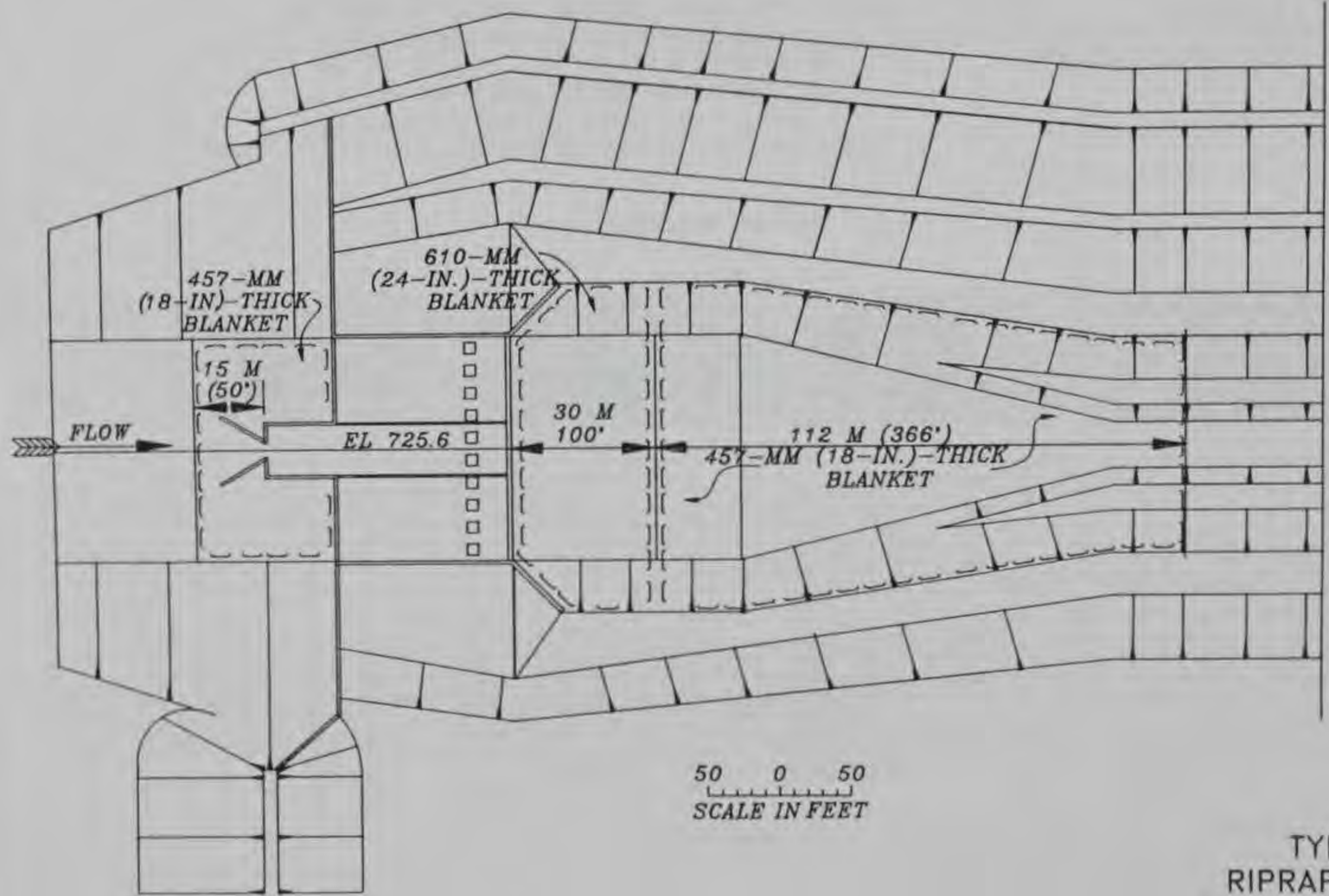

TYPE 2
RIPRAP DETAIL

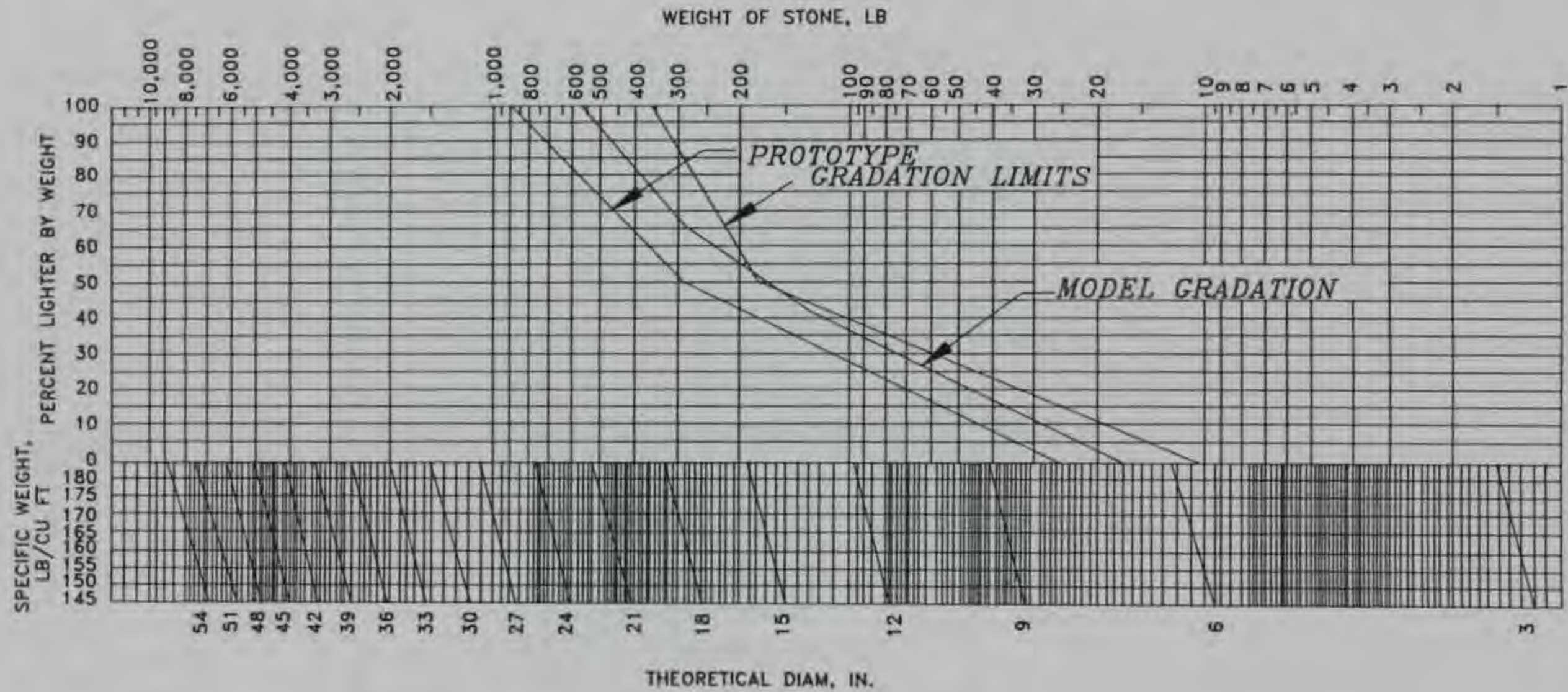

Note: Specific weight of stone 165 lb/cu ft.
 To convert pounds per cubic foot to kilograms per cubic meter, multiply by 16.01846. To convert pounds to kilograms, multiply by 0.453924. To convert inches to millimeters, multiply by 25.4

RIPRAP GRADATION CURVES
 610-MM-(24-IN.-)THICK BLANKET
 (CLASS B)

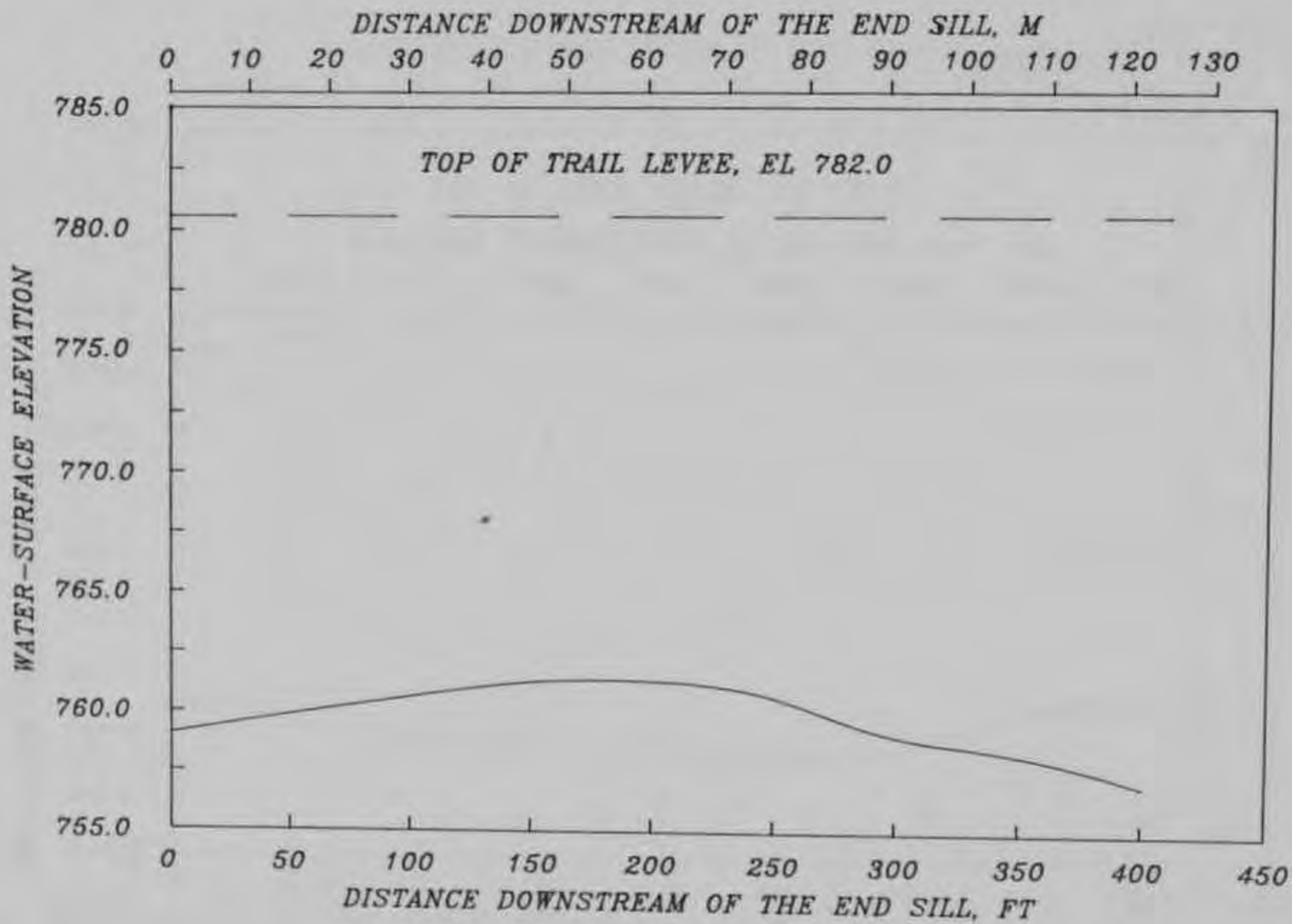

TRAIL LEVEE
 WATER-SURFACE PROFILE
 DISCHARGE 991 CU M/SEC (35,000 CFS)
 TAILWATER EL 759.71

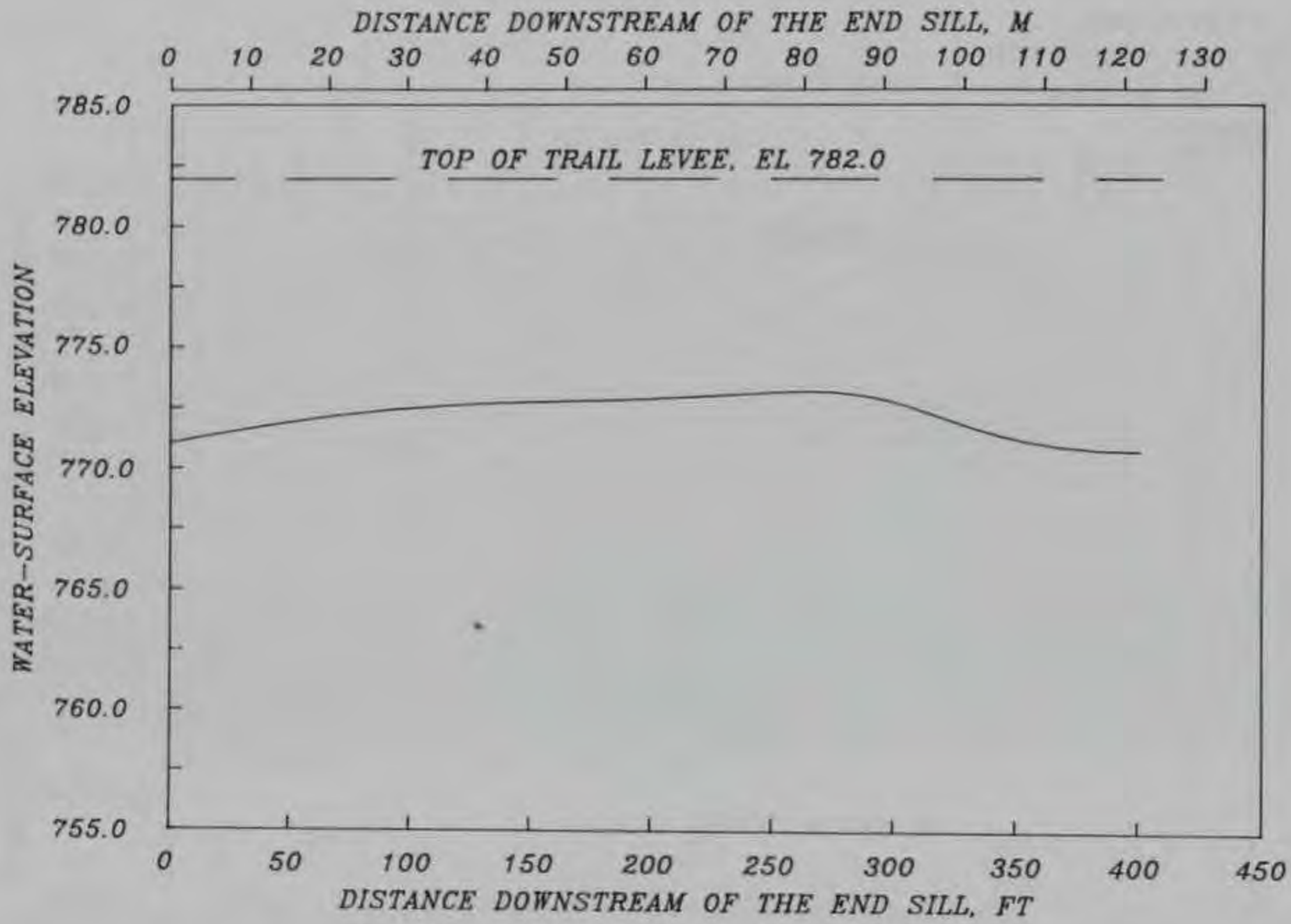

TRAIL LEVEE
- WATER-SURFACE PROFILE
DISCHARGE 1,557 CU M/SEC (55,000 CFS)
TAILWATER EL 766.71

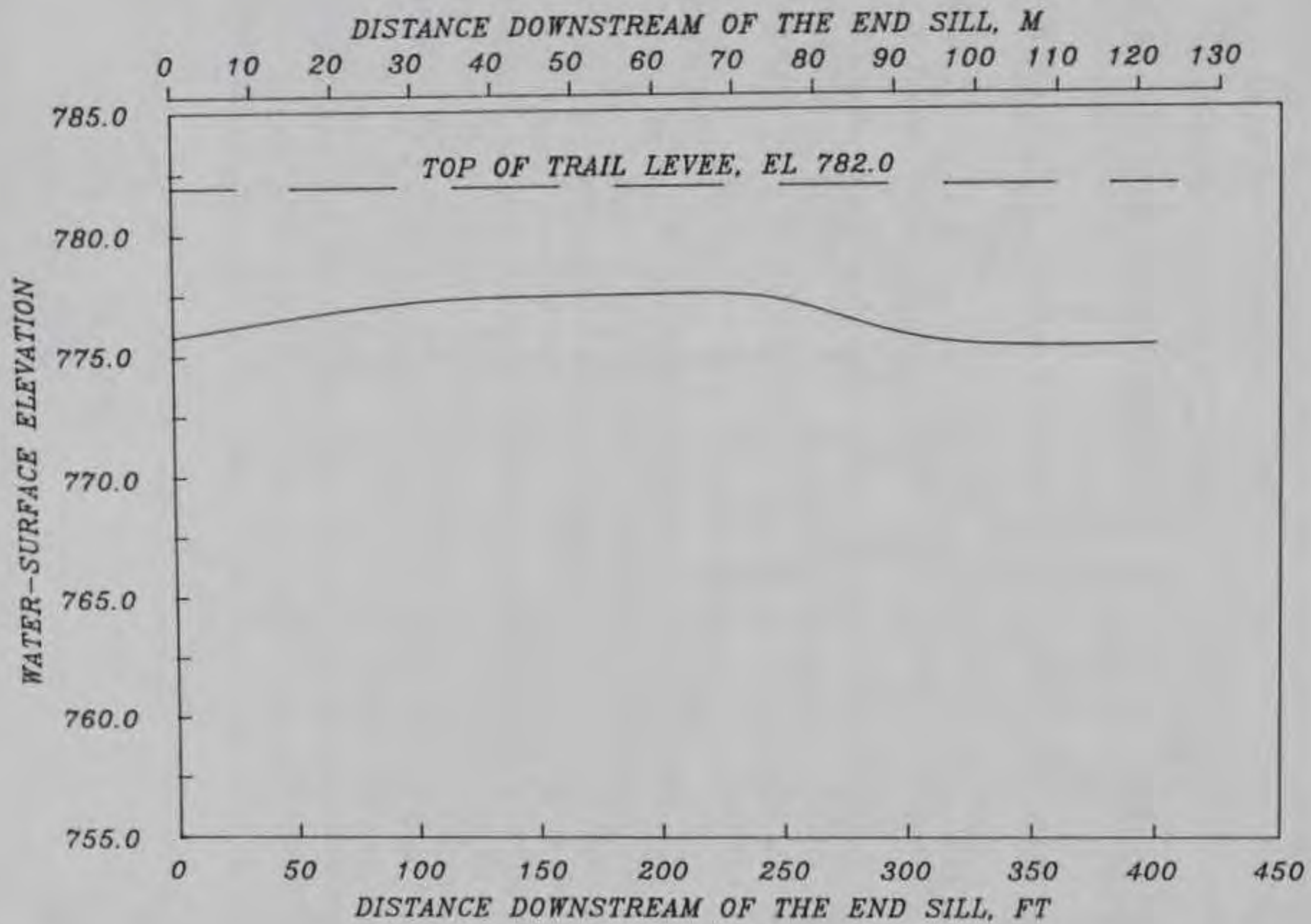

TRAIL LEVEE
 WATER-SURFACE PROFILE
 DISCHARGE 2,265 CU M/SEC (80,000 CFS)
 TAILWATER EL 772.28

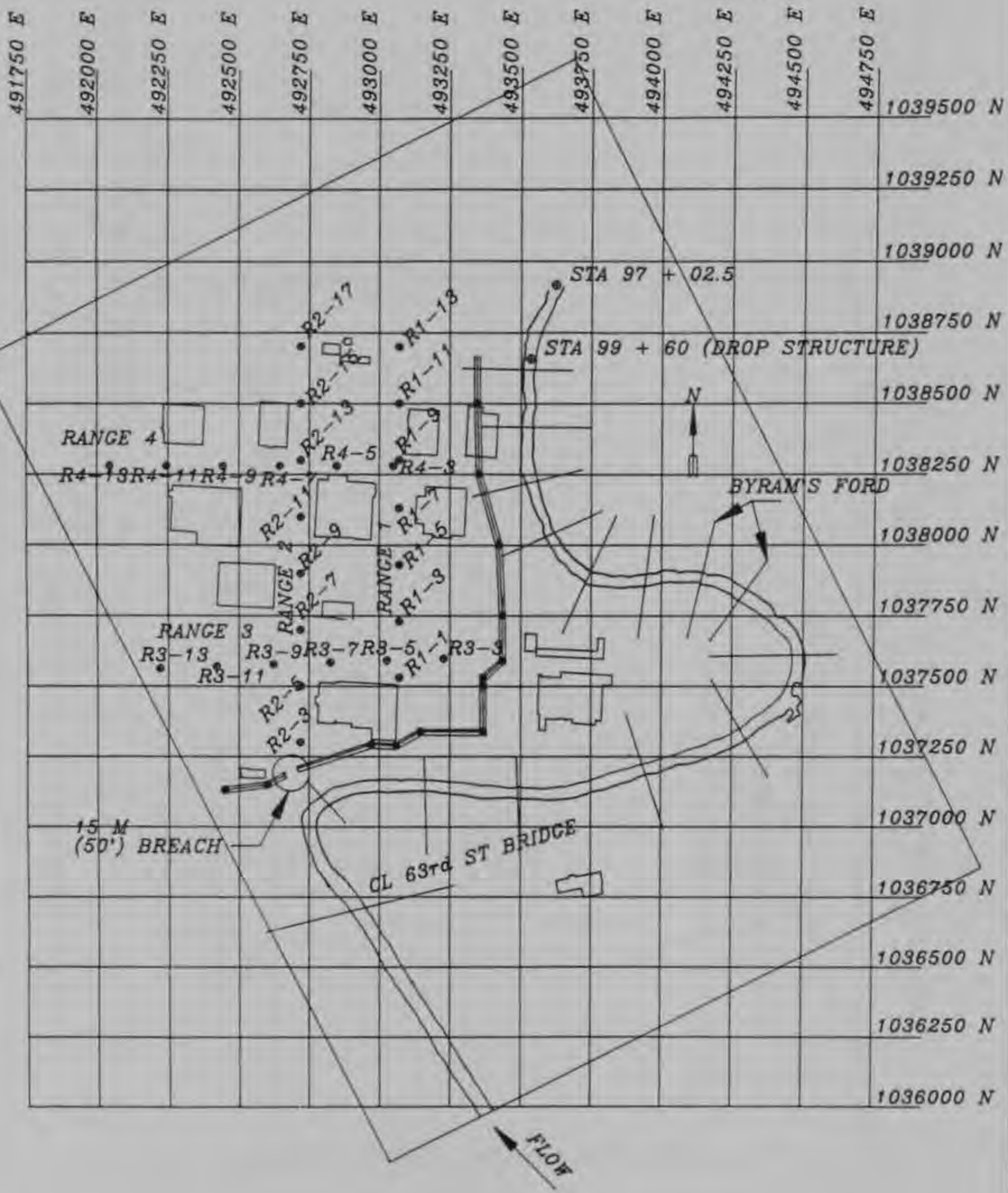
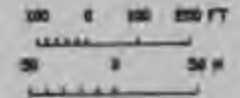

LOCATION OF
15-M (50-FT) BREACHED SECTION

REPORT DOCUMENTATION PAGE

Form Approved
OMB No. 0704-0188

Public reporting burden for this collection of information is estimated to average 1 hour per response, including the time for reviewing instructions, searching existing data sources, gathering and maintaining the data needed, and completing and reviewing the collection of information. Send comments regarding this burden estimate or any other aspect of this collection of information, including suggestions for reducing this burden, to Washington Headquarters Services, Directorate for Information Operations and Reports, 1215 Jefferson Davis Highway, Suite 1204, Arlington, VA 22202-4302, and to the Office of Management and Budget, Paperwork Reduction Project (0704-0188), Washington, DC 20503.

1. AGENCY USE ONLY (Leave blank)		2. REPORT DATE April 1996	3. REPORT TYPE AND DATES COVERED Final report	
4. TITLE AND SUBTITLE Grade Control Structure for Blue River, Kansas City, Missouri			5. FUNDING NUMBERS	
6. AUTHOR(S) Deborah R. Cooper				
7. PERFORMING ORGANIZATION NAME(S) AND ADDRESS(ES) U.S. Army Engineer Waterways Experiment Station 3909 Halls Ferry Road, Vicksburg, MS 39180-6199			8. PERFORMING ORGANIZATION REPORT NUMBER Technical Report HL-96-15	
9. SPONSORING/MONITORING AGENCY NAME(S) AND ADDRESS(ES) U.S. Army Engineer District, Kansas City 700 Federal Building Kansas City, MO 64106-2896			10. SPONSORING/MONITORING AGENCY REPORT NUMBER	
11. SUPPLEMENTARY NOTES Available from National Technical Information Service, 5285 Port Royal Road, Springfield, VA 22161.				
12a. DISTRIBUTION/AVAILABILITY STATEMENT Approved for public release; distribution is unlimited.			12b. DISTRIBUTION CODE	
13. ABSTRACT (Maximum 200 words) Channel improvements of the Blue River, a right-bank tributary of the Missouri River, extend from its confluence with the Missouri River upstream for approximately 12 river miles. These improvements were designed to contain a discharge of 991 cu m/sec (35,000 cfs) (a 30-year-frequency flood) with a coincident 10-year-frequency flood on the Missouri River. A grade control structure was designed as a three-stage weir. This structure was required to minimize erosion resulting from high velocities at the upstream end of the improved channel and the confluence with the unmodified channel and was located downstream of Byram's Ford and the Big Blue Battleground, a Civil War historic area nominated to the National Register of Historic Places in October 1989. A horizontal apron with baffle blocks and an end sill dissipated energy. The model study was conducted to determine how much flood protection could be provided in the Byram's Ford Industrial Park without adversely affecting cultural values of the historic site, reproduce the natural channel rating curve, examine energy dissipation problems expected downstream of the grade control structure, and determine the impact of the grade control structure on velocities and flow conditions at the Byram's Ford Civil War Crossing and riprap requirements for protection upstream and downstream of the structure.				
14. SUBJECT TERMS Blue River Hydraulics Velocities Byram's Ford Rating curves Weir Drop structure Riprap Grade control structure Stilling basin			15. NUMBER OF PAGES 220	
			16. PRICE CODE	
17. SECURITY CLASSIFICATION OF REPORT UNCLASSIFIED	18. SECURITY CLASSIFICATION OF THIS PAGE UNCLASSIFIED	19. SECURITY CLASSIFICATION OF ABSTRACT	20. LIMITATION OF ABSTRACT	