

SHIP SIMULATION STUDY OF JOHN F. BALDWIN (PHASE II) NAVIGATION CHANNEL SAN FRANCISCO BAY, CALIFORNIA

by

Carl Huval, Bradley Comes, Robert T. Garner III

Hydraulics Laboratory

DEPARTMENT OF THE ARMY
Waterways Experiment Station, Corps of Engineers
PO Box 631, Vicksburg, Mississippi 39180-0631

**BOOKS ARE ACCOUNTABLE PROPERTY CHARGED
TO AN INDIVIDUAL BY NAME. PLEASE DO
NOT LEND TO OTHERS WITHOUT CLEARING
YOURSELF.**



June 1985
Final Report

Approved For Public Release; Distribution Unlimited

LIBRARY BRANCH
TECHNICAL INFORMATION CENTER
US ARMY ENGINEER WATERWAYS EXPERIMENT STATION
VICKSBURG, MISSISSIPPI

Prepared for

US Army Engineer District, San Francisco
San Francisco, California 94105

TA7
W34
no. HL-
85-4

ny Corps
ineers

REFERENCE

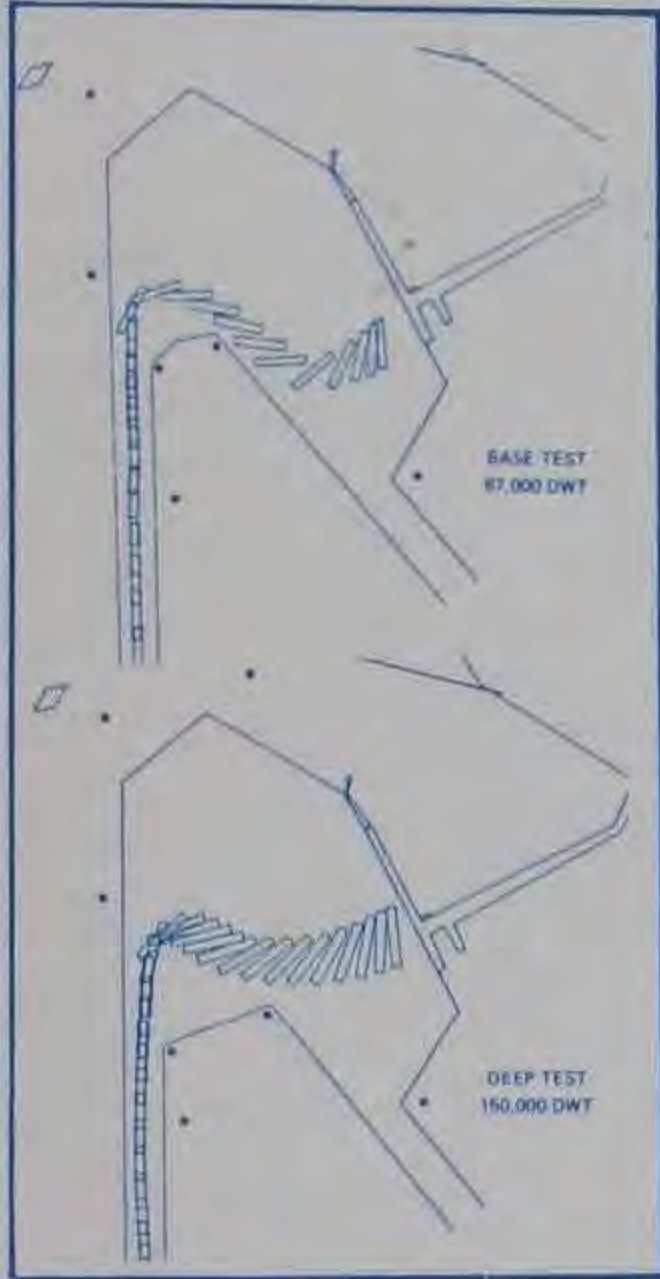

REPORT DOCUMENTATION PAGE		READ INSTRUCTIONS BEFORE COMPLETING FORM
1. REPORT NUMBER Technical Report HL-85-4	2. GOVT ACCESSION NO.	3. RECIPIENT'S CATALOG NUMBER
4. TITLE (and Subtitle) SHIP SIMULATION STUDY OF JOHN F. BALDWIN (PHASE II) NAVIGATION CHANNEL, SAN FRANCISCO BAY, CALIFORNIA		5. TYPE OF REPORT & PERIOD COVERED Final report
7. AUTHOR(s) Carl Huval Bradley Comes Robert T. Garner III		6. PERFORMING ORG. REPORT NUMBER
9. PERFORMING ORGANIZATION NAME AND ADDRESS US Army Engineer Waterways Experiment Station Hydraulics Laboratory PO Box 631, Vicksburg, Mississippi 39180-0631		8. CONTRACT OR GRANT NUMBER(s)
11. CONTROLLING OFFICE NAME AND ADDRESS US Army Engineer District, San Francisco 211 Main Street San Francisco, California 94105		10. PROGRAM ELEMENT, PROJECT, TASK AREA & WORK UNIT NUMBERS
14. MONITORING AGENCY NAME & ADDRESS (If different from Controlling Office)		12. REPORT DATE June 1985
		13. NUMBER OF PAGES 119
		15. SECURITY CLASS. (of this report) Unclassified
		15a. DECLASSIFICATION/DOWNGRADING SCHEDULE
16. DISTRIBUTION STATEMENT (of this Report) Approved for public release; distribution unlimited.		
17. DISTRIBUTION STATEMENT (of the abstract entered in Block 20, if different from Report)		
18. SUPPLEMENTARY NOTES Available from National Technical Information Service, 5285 Port Royal Road, Springfield, Virginia 22161		
19. KEY WORDS (Continue on reverse side if necessary and identify by block number) Channels (Hydraulic engineering) (LC) Harbors--California--San Francisco (LC) John F. Baldwin Navigation Channel (Calif.) (LC) Ships--Maneuverability--Simulation methods (LC) Tankers (LC)		
20. ABSTRACT (Continue on reverse side if necessary and identify by block number) The WES Research Ship Simulator was used to evaluate the design of Phase II of the John F. Baldwin Ship Channel and to study the impact of the deepened channel on the navigability of large tankers inbound to the Long Wharf docking facility near Richmond Harbor. The present channel and maneu- vering area is 35 ft deep and is inadequate for the larger tankers bringing crude oil from the Alaskan North Slope. The San Francisco District (Continued)		

20. ABSTRACT (Continued).

has proposed to deepen the channel to 45 ft deep. The authorized 35-ft-deep channel was simulated to verify the ship simulator setup as well as establish the base maneuvering strategies, and the proposed 45-ft-deep channel was simulated to study the proposed conditions. In addition to the tankers, container-ships navigating into Richmond Harbor entrance channel were also simulated to investigate the impact of channel deepening on other ships using the maneuvering area.

The proposed project will allow fully laden 87,000-dwt and partially laden 150,000-dwt tankers to unload at the Long Wharf. Present tanker operations require all but the smallest tankers to anchor in the main bay and off-load a substantial part of the cargo into shallower draft tankers that can be accommodated with the 35-ft-deep channel. The proposed channel will reduce transportation costs as well as reduce the possibility of oil spills in San Francisco Bay.

As a part of the project, a reconnaissance trip was made to observe ship and pilot operations and to record the inbound trip into the Long Wharf maneuvering area on a typical tanker presently using the channel. The channel geometry, the overbank depths, and the visual scene were then developed for the simulator using maps and photographs of the project area. All important visual information was included so as to provide the proper visual cues to the pilot conning the ship. Special tests were conducted on the San Francisco Bay-Delta Model to gather realistic tidal current data for input into the ship simulator. All simulations were run with a 20-knot wind blowing from the southwest.

Tests for the base and proposed channel conditions were conducted using 87,000-dwt partially laden (30-ft draft) and 150,000-dwt partially laden (40-ft draft) tankers, respectively. Both flood and ebb current conditions were simulated. In addition to ship track plots, several other critical parameters were plotted and studied, such as ship speed and docking posture as it approaches the Long Wharf. The main containership used to simulate future size ships calling at Richmond Harbor was 810 ft long and 106-ft beam loaded to a 32-ft draft. A smaller containership with 638-ft length and 100-ft beam was also used to simulate present-day ship sizes.

Test results indicate that it is very important to reduce tanker speed in Southampton Channel for inbound transits to about 5 knots before starting the large right turn into the maneuvering area. Acceptable docking postures can be achieved for both existing and proposed channel conditions under both ebb and flood tide so as to allow safe tanker docking into the Long Wharf. The containership tests indicate that it is reasonably safe to maneuver around the point and line up with the Richmond Harbor entrance channel on flood tide. Ebb tide conditions require very careful control of ship speed and position to execute a safe turn in the maneuvering area when piloting the 810-ft containership. The 638-ft containership was much easier to maneuver around the point.

PREFACE

This investigation was performed by the Hydraulics Laboratory of the U. S. Army Engineer Waterways Experiment Station (WES) for the U. S. Army Engineer District, San Francisco (SPN). The study was conducted with the WES research ship simulator. Authority for the investigation was given by SPN in SPNPE-TE letter of 20 May 1983. SPN provided the essential field and model data required. The study was conducted during the period June 1983-March 1984. The main study results were presented at a general design/checkpoint conference at San Francisco on 19 January 1984 and repeated at the project public meeting on 16 February 1984.

The investigation was conducted by Messrs. Carl Huval, Bradley Comes, and Robert T. Garner III of the Mathematical Modeling Group, under the general supervision of Messrs. H. B. Simmons and Frank A. Herrmann, Jr., former and successive Chiefs of the Hydraulics Laboratory, and M. B. Boyd, Chief of the Hydraulic Analysis Division.

Acknowledgment is made to Messrs. Jay Soper and Rod Chisholm, Planning/Engineering Division, SPN, for their cooperation and assistance at various times throughout the investigation. Special thanks should go to the tanker operations officials and pilots of the Chevron Richmond Refinery for access to an inbound tanker into the Long Wharf and for furnishing a professional pilot to conduct ship simulator tests on the WES ship simulator.

Commanders and Directors of WES during the conduct of this investigation and the preparation and publication of this report were COL Tilford C. Creel, CE, and COL Robert C. Lee, CE. Technical Director was Mr. F. R. Brown.

CONTENTS

	<u>Page</u>
PREFACE	1
CONVERSION FACTORS, NON-SI TO SI (METRIC) UNITS OF MEASUREMENT	2
PART I: INTRODUCTION	5
PART II: THE SCENARIO SETUP	7
PART III: TEST PROCEDURES	18
PART IV: TEST RESULTS	21
PART V: CONCLUSIONS AND RECOMMENDATIONS	48
Conclusions	48
Recommendations	49
APPENDIX A: SHIP SIMULATION TEST RESULTS FOR ALL TRIALS	A1
FIGURES A1-A68	

CONVERSION FACTORS, NON-SI TO SI (METRIC)
UNITS OF MEASUREMENT

Non-SI units of measurement used in this report can be converted to SI
(metric) units as follows:

<u>Multiply</u>	<u>By</u>	<u>To Obtain</u>
feet	0.3048	metres
feet per second	0.3048	metres per second
knots (international)	0.514444	metres per second
miles (US statute)	1.609344	kilometres
deadweight tons (English or long)	1.01605	tonnes (kilograms)

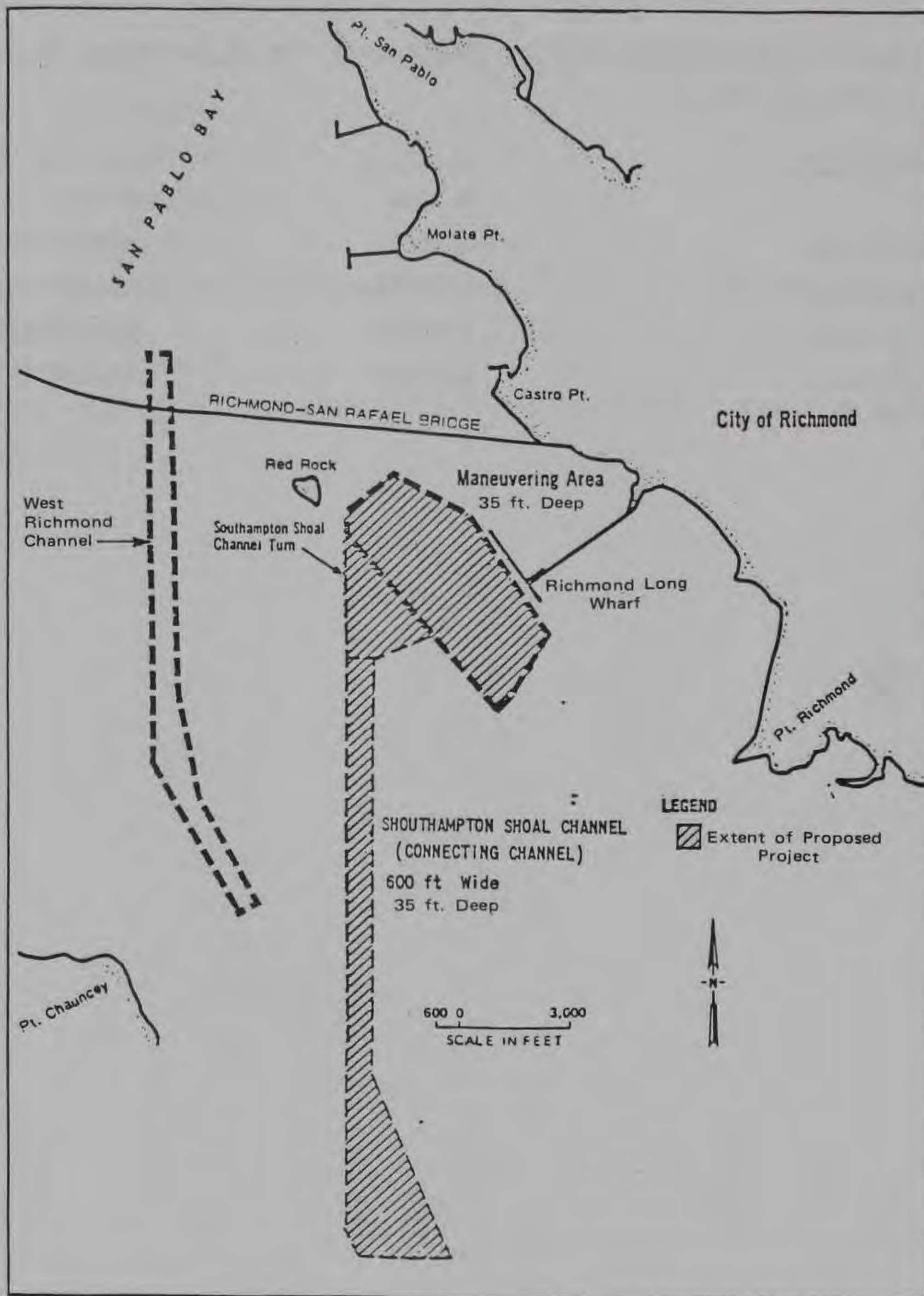

Figure 1. Study area

SHIP SIMULATION STUDY OF JOHN F. BALDWIN (PHASE II)
NAVIGATION CHANNEL, SAN FRANCISCO BAY, CALIFORNIA

PART I: INTRODUCTION

1. The Central San Francisco Bay Segment of the John F. Baldwin Ship Channel (Phase II) Project consists of the Richmond Long Wharf maneuvering area and the 1.1-mile*-long Southampton Shoal Channel, both located west of Richmond, California. The purpose of the project is to provide a direct and safe route for large tankers transporting crude petroleum stocks to the Richmond Long Wharf loading-unloading facility. The existing channel available to the tankers (Southampton Shoal and the Long Wharf maneuvering area, Figure 1) has an authorized depth of 35 ft mean lower low water (mllw). This restriction requires many of the more modern tankers with larger capacities and deeper drafts to be lightered or to wait for a high tide in order to use the channel. Both of these operational alternatives have economic and environmental costs as follows:

- a. Waiting for the proper tide conditions in combination with the required lightering time increases the operating costs of the refinery facility and decreases the number of tankers that can call at the Richmond Long Wharf.
- b. The off-loading of crude oil while anchored in San Francisco Bay increases the possibility of an oil spill.

2. The US Army Engineer District, San Francisco (SPN), is evaluating a proposal to deepen the existing channel and maneuvering area to a depth of 45 ft mllw. The existing project is presently being used by partially laden 87-kdwt tankers (loaded to 30-ft draft or more, depending on the tide) and the proposed deepening would allow fully laden 87-kdwt tankers (40-ft draft) or partially laden 150-kdwt tankers (loaded to 40-ft draft or more, depending on the tide). The District Office has asked the US Army Engineer Waterways Experiment Station (WES) to conduct a study using the ship simulator facility to answer several questions with respect to navigation of vessels in the

* A table of factors for converting non-SI units of measurement to SI (metric) units is presented on page 3.

proposed channel. The following questions were investigated as part of the study on the WES ship simulator:

- a. Is it possible for the large 150-kdwt tankers loaded to 40-ft draft to make the required maneuver from the north end of Southampton Shoal Channel into a proper docking posture at the Richmond Long Wharf?
- b. What possible changes in the geometry of the channel or the maneuvering area should be made to improve safety in the area with respect to navigation?
- c. Would the proposed project require any new or unexpected maneuvering strategies that should be brought to the vessel pilot's attention?
- d. Would deepening the channel and the maneuvering area affect the maneuverability of any existing vessels, i.e. containerships, using the study area en route to Richmond Harbor?

3. The channel scenario documentation, simulator methodology, and test results for this study are presented in the following report.

PART II: THE SCENARIO SETUP

4. Two scenarios were created for the project: one for the existing (authorized) navigation condition and one for the proposed conditions. The following information is required for the scenario setup:

- a. The geometry of the navigation channels in the study area.
 - (1) The width.
 - (2) The depth.
 - (3) The side slopes.
 - (4) The overbank depths on each side of the channel.
- b. The magnitudes and directions (azimuths) of the currents in the area.
- c. The magnitude and direction (azimuth) of the wind in the area.
- d. The wave height in the study area.
- e. The visual scene and radar image.

5. To define the geometry of the navigation area, cross-section definitions were placed as shown in Figures 2 and 3 for the existing and proposed maneuvering areas, respectively. The ship simulator model allows eight equally spaced points to be defined on each cross section. At each of these points a depth, current magnitude, and current direction are required. Also, for each cross section, the width, right and left side slopes, and overbank depth are required. Table 1 gives the values that were assigned for these parameters with the exception of the current magnitudes and directions which are discussed later in this part. Figure 4 shows a typical existing (as measured) cross

Table 1
Cross-Section Parameters

<u>Parameter</u>	<u>Authorized Channel</u>	<u>Proposed Channel</u>
Width of Southampton Channel	600 ft	600 ft
Width of maneuvering and turning areas	Varies	Varies or no change
Water depth (mllw)	35 ft	45 ft
Overbank depth (mllw)	28 ft	28 ft
Side slopes	1V on 2H	1V on 3H

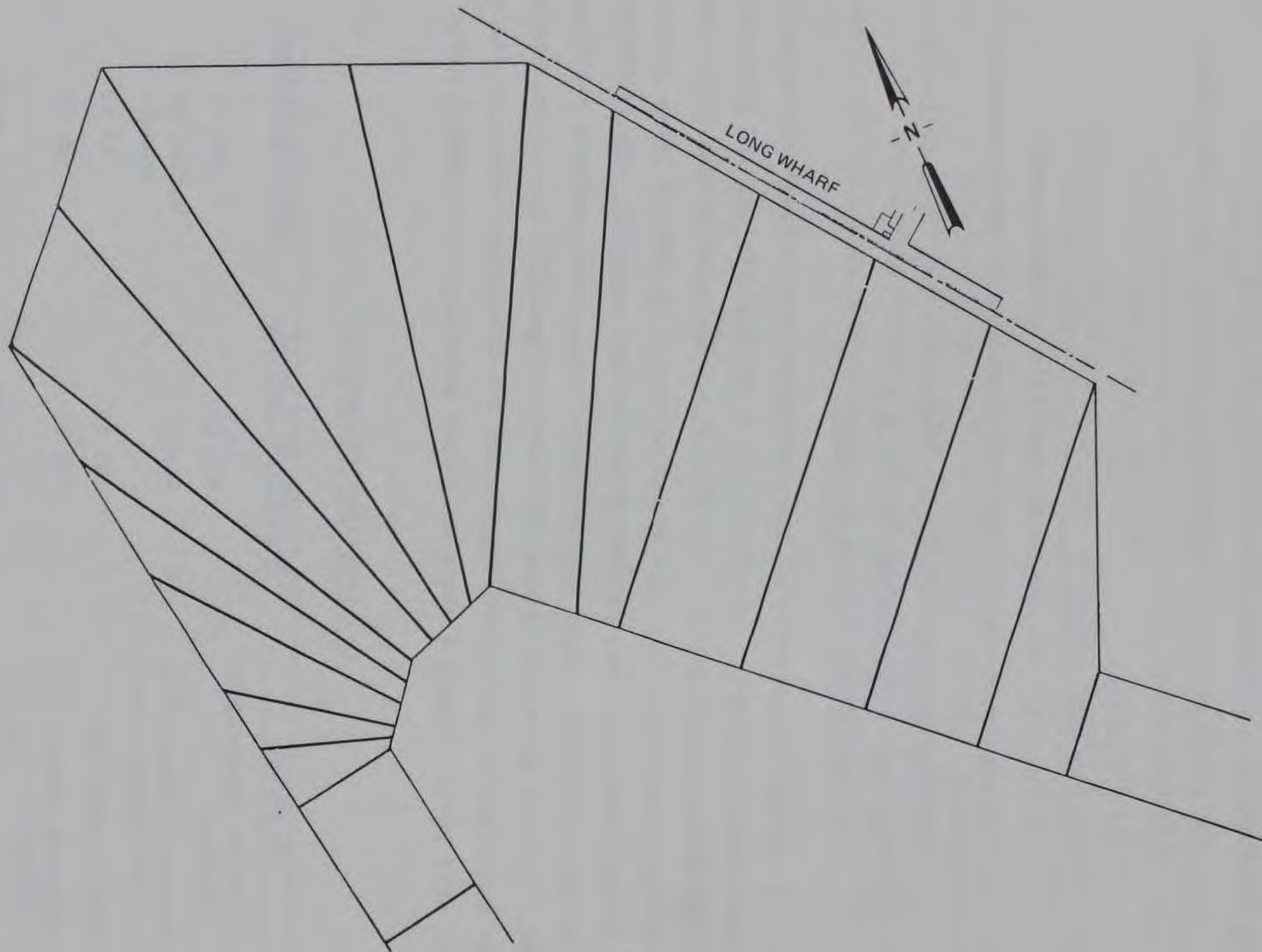

Figure 2. Cross-section layout, existing geometry

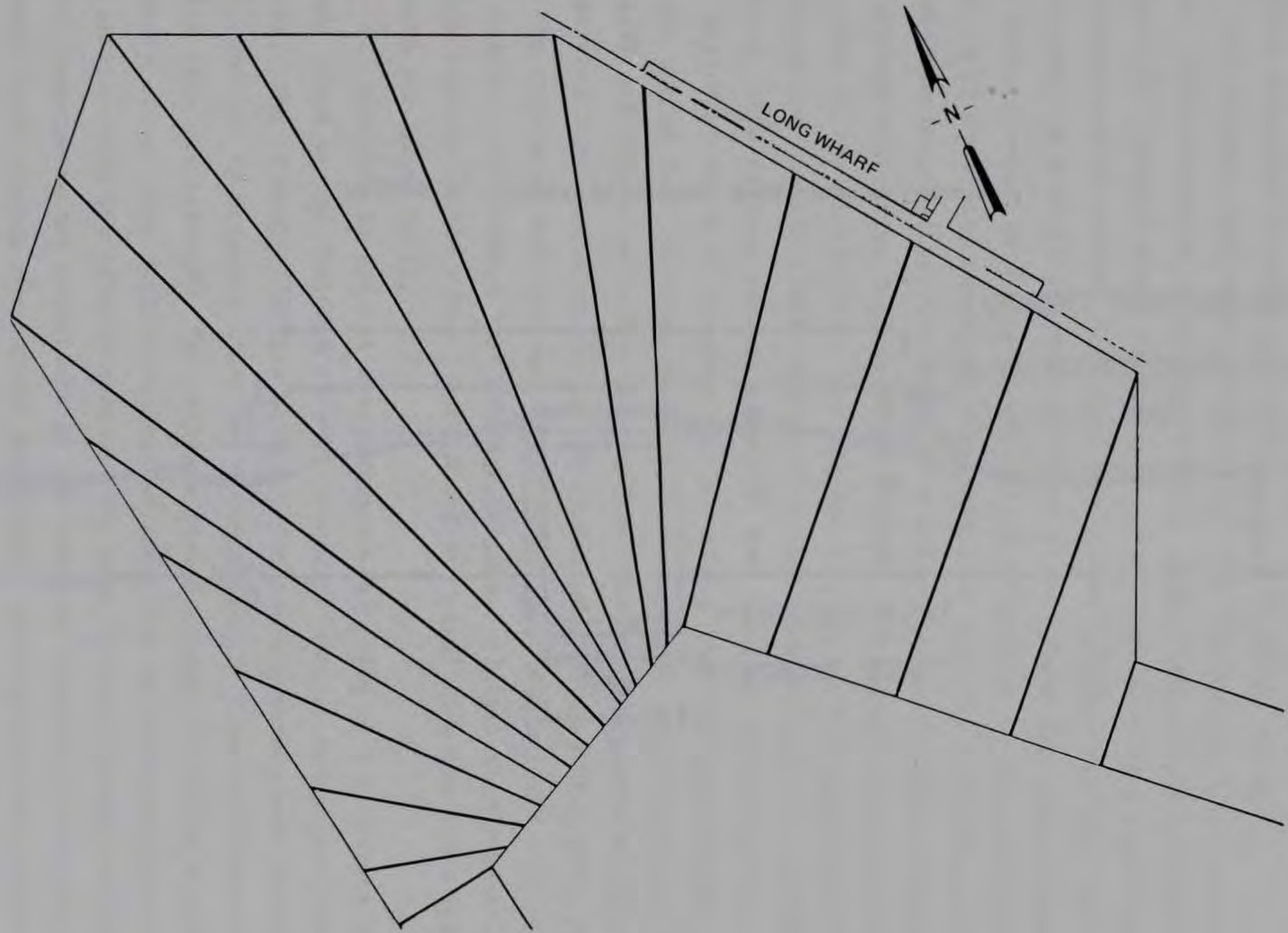

Figure 3. Cross-section layout, proposed geometry

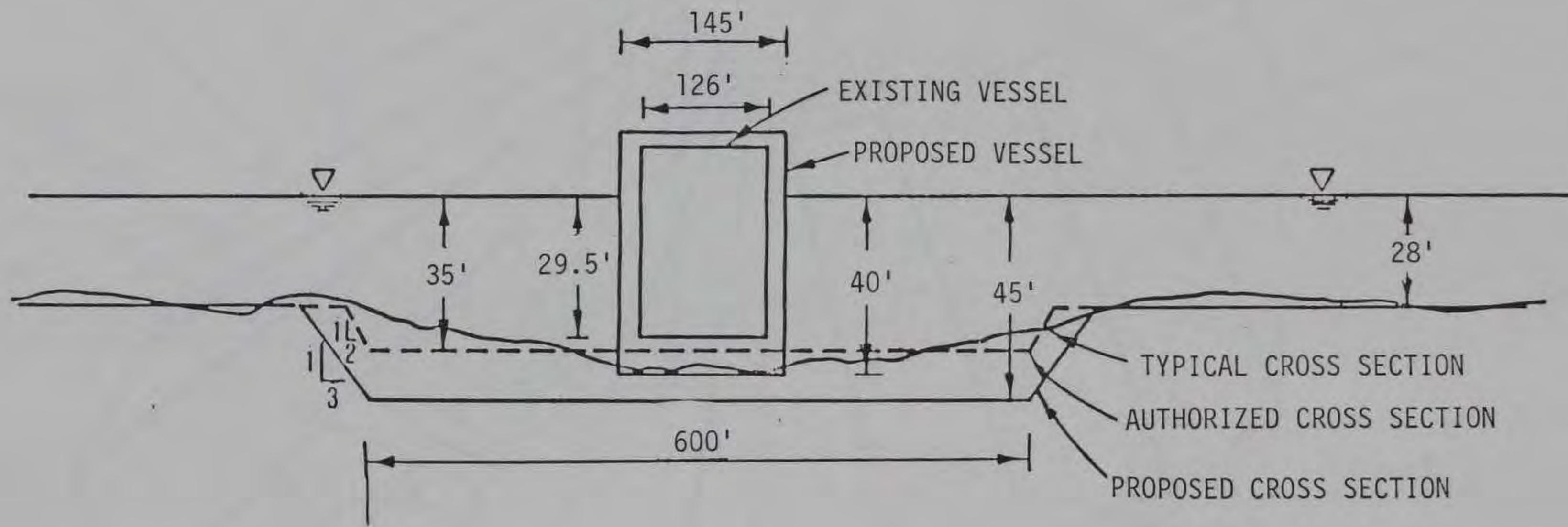

Figure 4. Cross sections, Southampton Channel

section, the presently authorized cross section, and the proposed cross section for Southampton Channel. Note also the representation of the respective vessel sizes. It was determined that the difference between ship draft and overbank depth was so small that the bank forces on the vessel would be negligible; therefore a constant overbank depth of 28 ft was used.

6. Current data were obtained from the San Francisco Bay physical model. Nine miniature Price-type current meters were placed in the study area (Figure 5). Several tidal cycles (mean tide) were simulated and 40 current magnitudes and directions from each meter were recorded for each full tidal cycle near the surface and bottom of the flow. These data were recorded for each current meter on a time-history graph (Figure 6) as well as in tabular form. A study of the tabulated data indicated that the differences between the maximum measured surface and bottom velocities were within 10 percent with the surface velocities tending to be larger. The measured surface velocities were used in the simulation. The maximum surface current magnitudes (one each for flood and ebb tide) were chosen from each current graph. For each meter location, this maximum current magnitude was found in the tabular data and the time period at which it occurred was recorded. The time periods were analyzed and the period that occurred the most often for each tidal condition (flood and ebb) was chosen to be the time at which the maximum currents occurred. It was at this time period that a current magnitude and direction were chosen from the tabulated data for each meter location. This results in a conservative design. The maximum currents are the most critical with respect to maintaining control of the vessel. These current magnitudes and their respective azimuths are shown in Figure 7.

7. A method of spatial averaging and smoothing of the current data was devised based on the Thiessen Network procedure used in hydrologic rainfall studies. The adjacent stations at which the current meters were positioned were connected by straight lines and a perpendicular bisector to each connecting line was erected. The polygons formed (Figure 7) by the perpendicular bisectors around each station enclose an area that is everywhere closer to that station than any other station. This area is best represented by the current magnitudes and directions at the enclosed station. A smoothing process was used in allocating the current magnitudes and directions to each of the eight points on each channel cross section (Figures 8 and 9). This was done to avoid abrupt changes in currents which would not be representative of

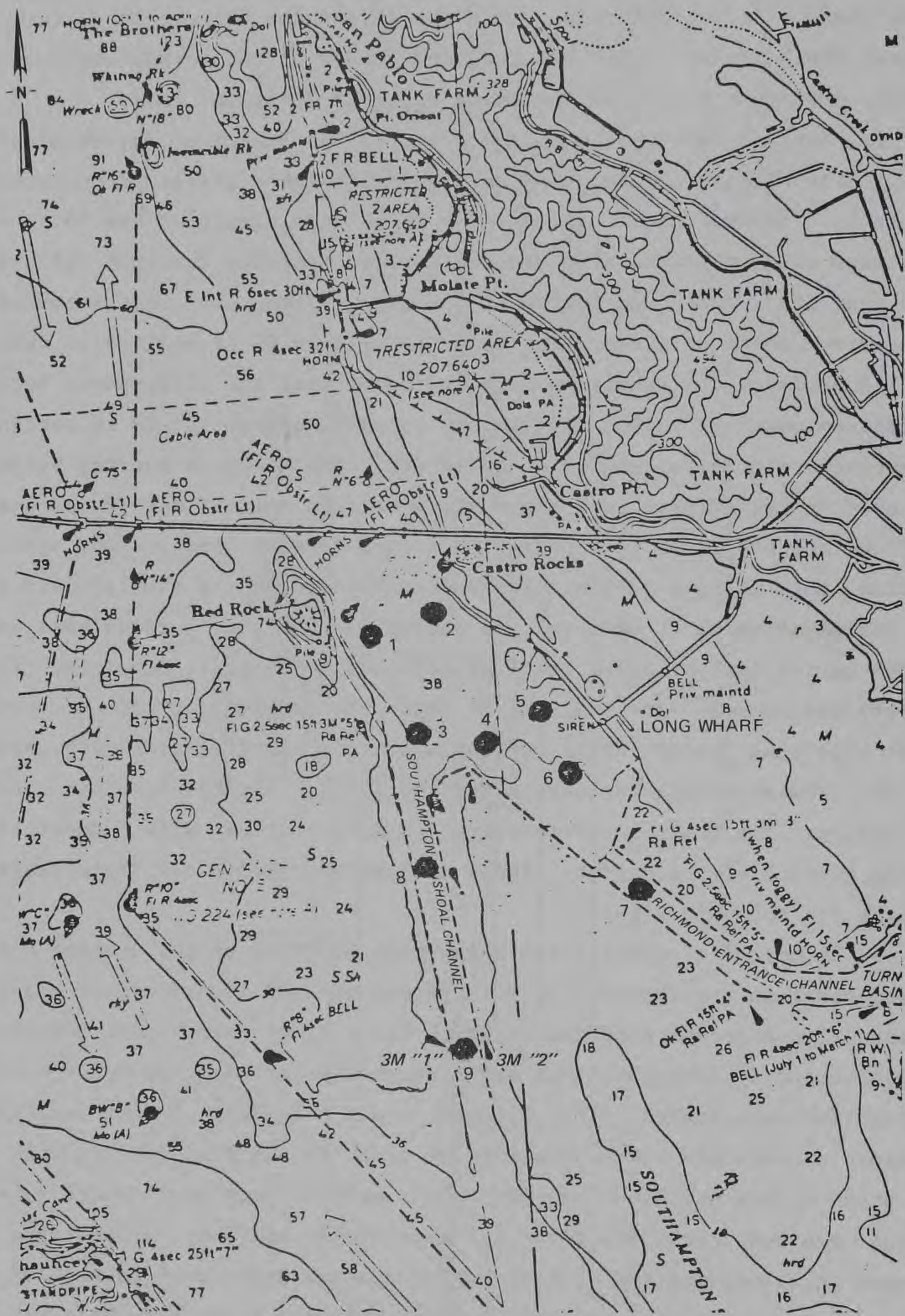

Figure 5. Current meter locations

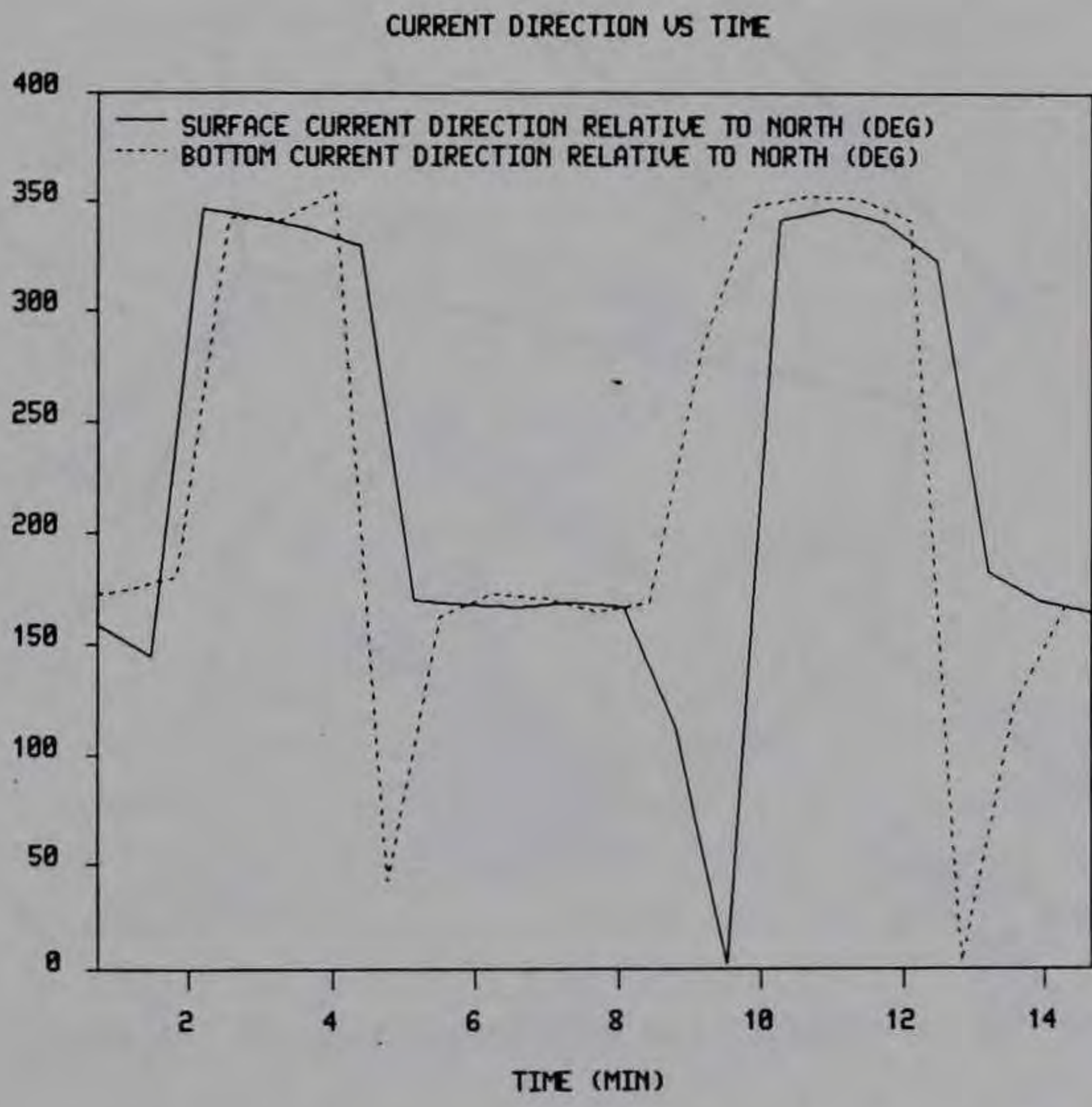
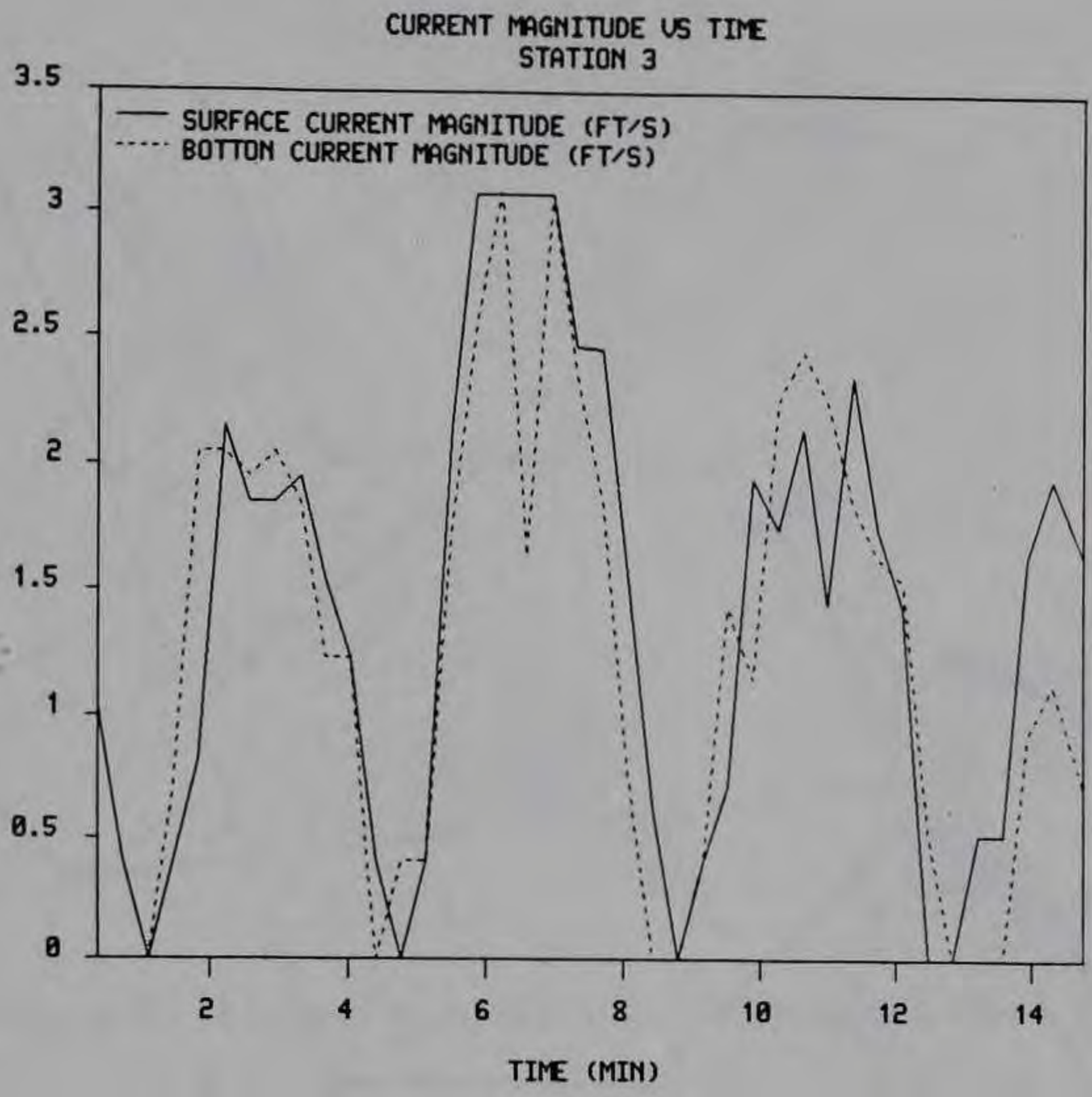

Figure 6. Physical model currents at Station No. 3

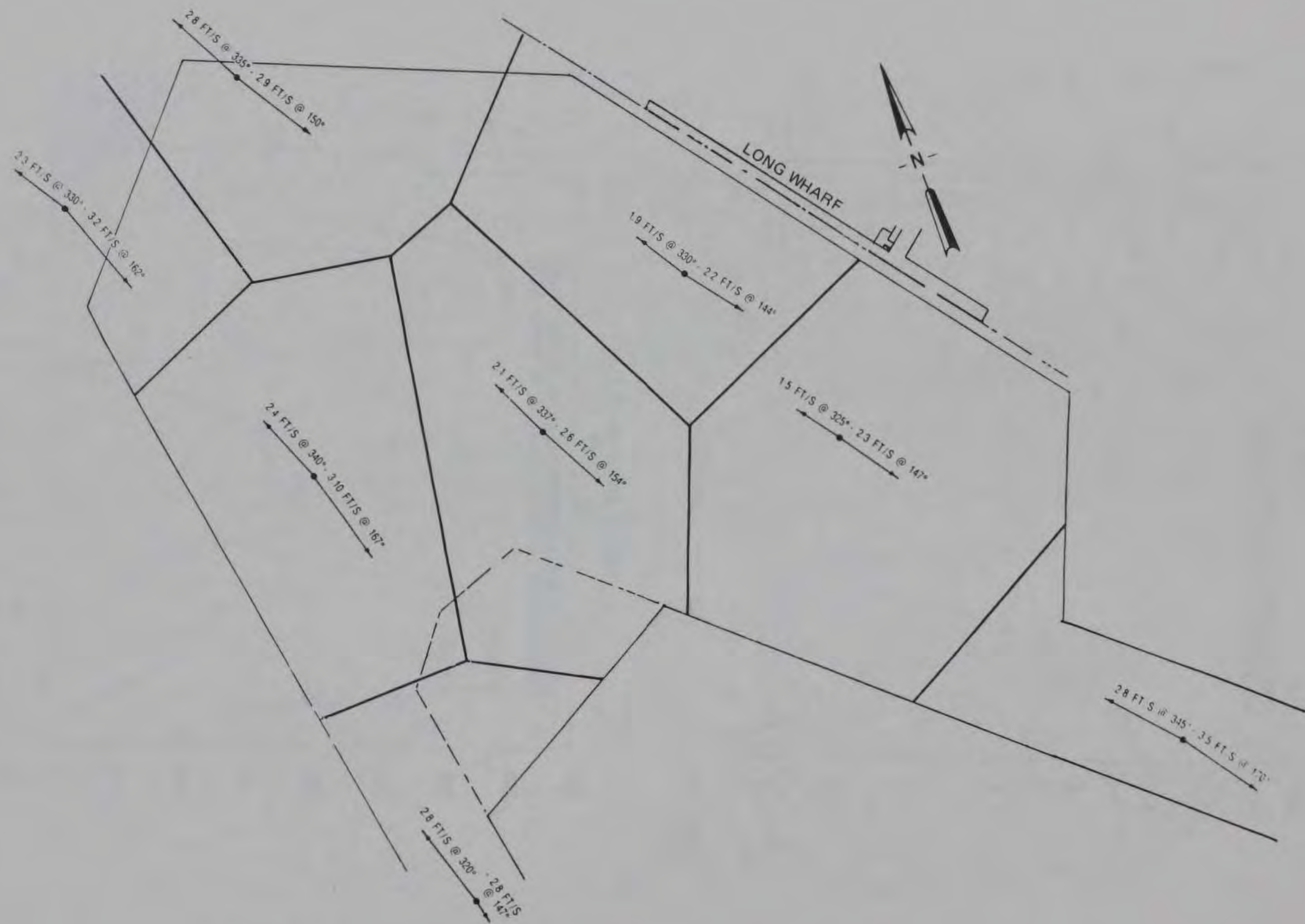

Figure 7. Maximum currents (flood and ebb tide) for mean tide

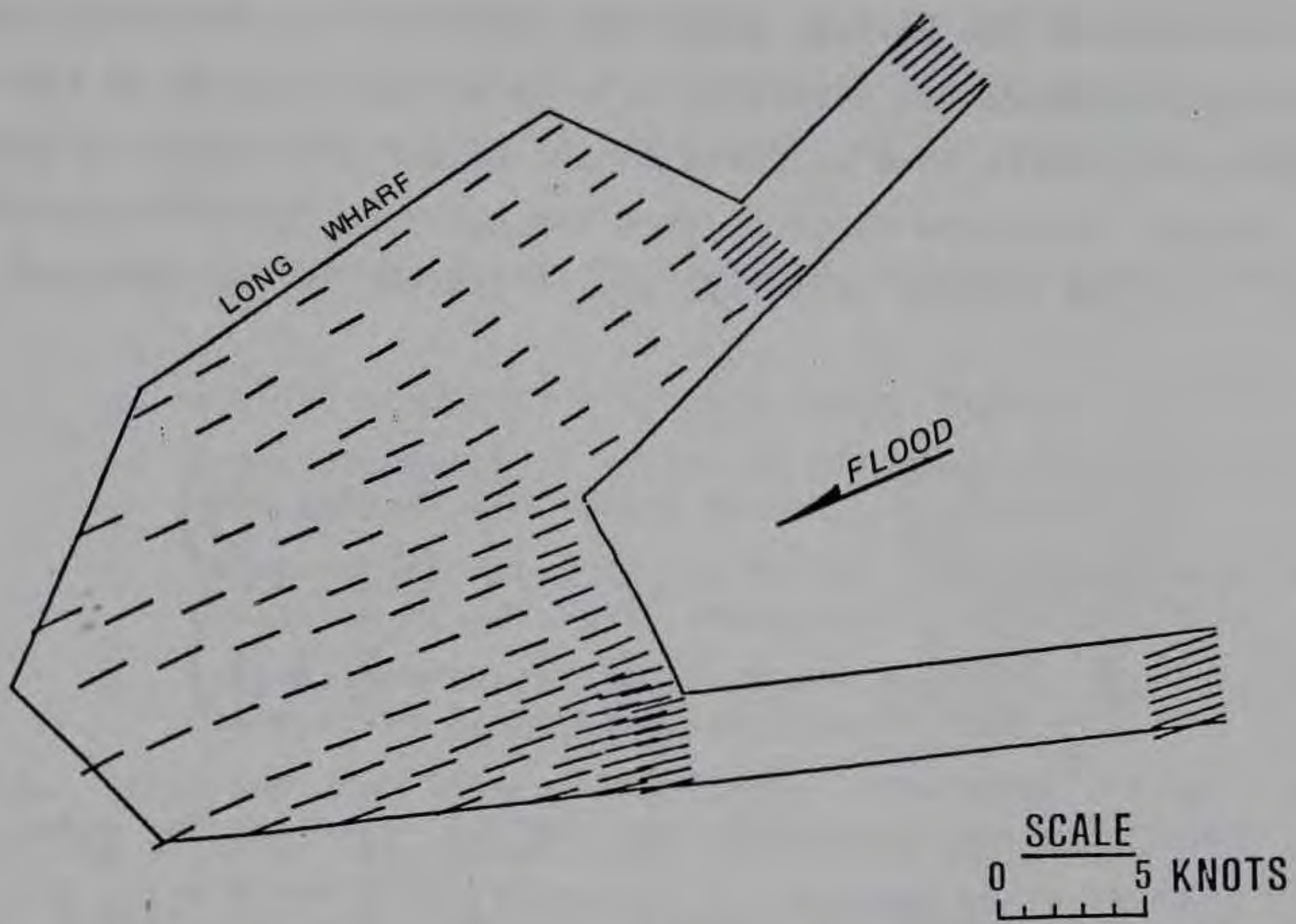

Figure 8. Current magnitudes and directions, flood tide

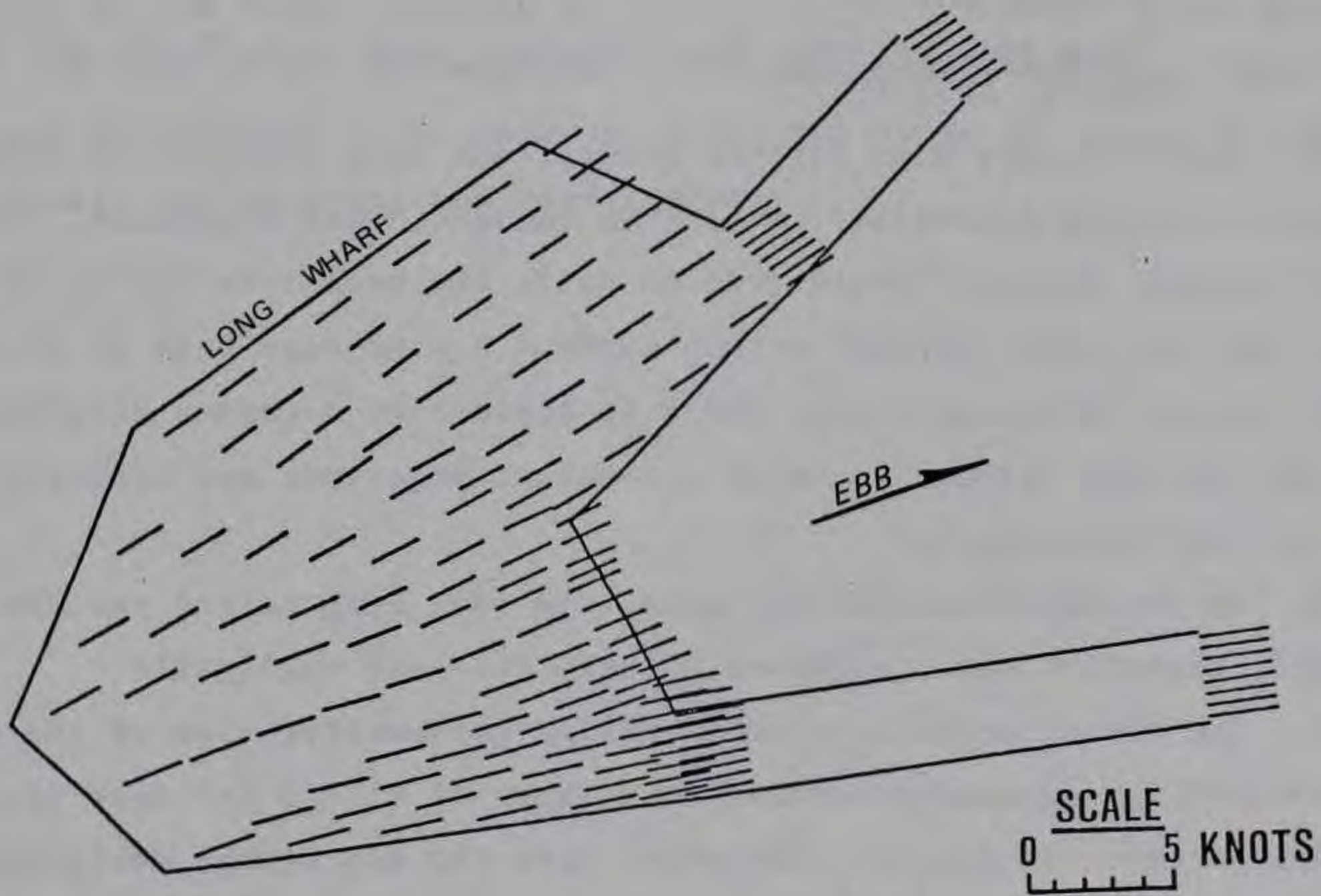

Figure 9. Current magnitudes and directions, ebb tide

real-world conditions. The smoothing method involved assigning to each point on each cross section the current magnitude and direction of the occupied area as well as the magnitude and direction from each area adjacent to the occupied area. These values were then weighted to the point in question by the use of Equation 1 where R is the distance from the point to the i^{th} current meter position, V is the current velocity, and A is the current azimuth.

$$\frac{\sum_{i=1}^n (V_i) \left(\frac{1}{R_i^2}\right)}{\sum_{i=1}^n \left(\frac{1}{R_i^2}\right)} \quad \text{and} \quad \frac{\sum_{i=1}^n (A_i) \left(\frac{1}{R_i^2}\right)}{\sum_{i=1}^n \left(\frac{1}{R_i^2}\right)} \quad (1)$$

8. The current data obtained from the San Francisco Bay model were checked using three other sources. A reasonably good correlation between the four was found. The other sources are listed below:

- a. Tidal Current Charts for The San Francisco Bay; U. S. Department of Commerce, National Oceanic and Atmospheric Administration and The National Ocean Survey, July 1973.
- b. 1983 Tide & Current Tables with Current Charts; Crowley Maritime Corporation, 1983.
- c. Tides and Currents, San Francisco Bay; U. S. Coast and Geodetic Survey, 1873-1923.

9. The wind data used for the simulations were supplied by SPN. The predominant wind was determined to be from the southwest direction. For the maneuvers tested, the wind would tend to drift the vessel to the north making the turn more difficult in very strong winds. A wind magnitude of 20 knots was used for all navigation tests which is typical of a summer afternoon bay wind. The wind was assumed to be at a constant magnitude and direction throughout the study area.

10. In the San Francisco Bay area, the wave heights and periods are very small; therefore wave forces on a large ship are negligible.

11. The visual scene is a color-filled perspective view of the navigation area that is computer-generated on a large (4 ft x 3 ft) rear projection television screen. It provides the pilot with the key visual navigation aids (buoys, channel markers, buildings, bridges, etc.) that are used in the real world situation. The information required to generate the visual scene must

be encoded for the model in three dimensions: north-south, east-west, and vertical elevation. As the ship is moving, the three-dimensional picture is constantly being transformed into a two-dimensional perspective graphic image representing the relative size of the objects in the scene as a function of the vessel's position.

12. Data sources used for the development of the visual scene are given below:

- a. A video taping of a typical vessel transit.
- b. Still photographic slides of the area taken from the land as well as from the vessel transit.
- c. Topographic maps produced by the U. S. Geological Survey and published by the U. S. Department of the Interior.
- d. Nautical charts produced by the National Ocean Survey, National Oceanic and Atmospheric Administration; chart No. 18649.

13. Items included in the visual scene consisted of buoys, channel markers, the Richmond Long Wharf, some of the key buildings, the San Rafael-Richmond Bridge, the gas tank, oil pumpers, Red Rock Island, west land masses near San Quentin, east land masses extending from Pt. San Pablo south to Brooks Island, and all significant topography.

14. The radar image is a continuously updating plan view of the vessel's position relative to the surrounding area. The information supplied to the pilot by the radar consists of the radius of the image being generated, a visual location of the vessel, and all objects coded into the visual scene. The information required to generate the radar image is common to the information required to generate the visual scene.

PART III: TEST PROCEDURES

15. The study consisted of two test cases. The first case was the base condition and tested the ability of 87-kdwt tankers to maneuver in the presently authorized 35-ft-deep Southampton Shoal Channel, the Long Wharf maneuvering area, and to approach the Long Wharf in a correct docking posture (to be described later) without tugboat assistance. The second case was the proposed or deepened channel, and tested the ability of 150-kdwt tankers to maneuver from the Southampton Shoal Channel, through the Long Wharf maneuvering area, and into a correct docking posture at the Long Wharf (also without tugboat assistance). The impact of channel deepening on Richmond Harbor navigation was also investigated by testing the ability of two different containerships to maneuver from the Southampton Channel, through the Long Wharf maneuvering area, and into the Richmond Harbor entrance channel.

16. Three pilots were used in the testing program; their respective backgrounds are given below.

- a. Pilot A is an experienced WES engineer familiar with the hydrodynamics of ship behavior on the simulator but is naive from a ship piloting standpoint.
- b. Pilot B is a new WES engineer who has some familiarity with the hydrodynamics of the simulator but has no ship piloting experience.
- c. Pilot C is an experienced Chevron tanker master and an active pilot familiar with tanker response and piloting into the Long Wharf.

17. The investigations consisted of testing the following channel-tanker-tide conditions:

- a. The authorized 35-ft-deep channel with an 87-kdwt partially loaded tanker to nearly 30-ft draft (see Table 2 for ship particulars).
- b. The proposed 45-ft-deep channel with a 150-kdwt partially loaded tanker to 40-ft draft (see Table 2 for ship particulars).
- c. Conditions (a) and (b) were tested with both flood and ebb tide currents as shown in Figures 8 and 9.
- d. All tests were for inbound transits and for ships loaded to the maximum draft that the channel design would allow.

18. The base tests were conducted in such a manner as to reproduce existing conditions (with the exception of tugboat assistance) to verify the scenario setup as well as the ship simulator model response. Once existing

Table 2
Ship Particulars, Typical Tankers

<u>Ship</u>	<u>Load Condition</u>	<u>Capacity kdwt</u>	<u>Length ft</u>	<u>Beam ft</u>	<u>Draft, ft</u>	
					<u>Partial Load</u>	<u>Full Load</u>
Chevron <u>California</u>	Partial	70	801	105	28.5	42.8
Simulated base ship	Partial	87	763	125	29.5	40.0
Chevron <u>H. J. Haynes</u>	Partial	150	899	160	40.0	52.8
Simulated design ship	Partial	150	915	145	40.0	52.0

conditions were verified, the proposed channel and tanker configurations were tested. Table 5 (page 23) gives a complete outline of tanker tests completed.

19. Prior to collecting the data from the actual test runs, approximately six familiarization trials were required for Pilots A and B and two for Pilot C.

20. In addition to testing the tankers, tests were conducted with the proposed 45-ft-deep channel with a 638-ft and an 810-ft containership (see Table 3 for ship particulars). The tide and current conditions (Figures 8 and 9) were the same as those tested with the tankers. Only Pilots A and B

Table 3
Ship Particulars, Typical Containerships

<u>Ship</u>	<u>Capacity kdwt</u>	<u>Capacity TEU*</u>	<u>Length ft</u>	<u>Beam ft</u>	<u>Draft ft</u>
Sea Land SL-7	20-35	1220-1230	725-944	95-105	33-38
APL <u>President Lincoln</u>	30	1750	821	106	29.6
MARAD design	40	2500	810	106	29.6
Simulated large containership	44	2600	810	106	32.0
Simulated small containership	15	882	638	100	32.8

* Twenty-foot equivalent units.

performed testing of the containerships and only inbound transits were tested.

21. All tests began with the vessel located at the center of Southampton Channel near channel markers 3M"1" and 3M"2" (the south end of Southampton Channel near current meter number 9 (Figure 5, page 12)) with the heading being the same as the channel itself (353 deg). The initial speed of the 87-kdwt and 150-kdwt tankers was 5 and 2 knots, respectively; the initial speed of the containerships was 5 knots. All speeds listed are with respect to the bottom of the channel.

PART IV: TEST RESULTS

22. When analyzing the test results presented here and in Appendix A, it should be kept in mind that all of the vessel transits were completed without the assistance of tugboats. With the assistance of tugboat simulation it would have been possible to totally simulate the procedures used in the real world; however, it is believed that if the vessels can perform the required maneuvers without the assistance of tugboats, then having the assistance provides an optional safety factor. The rationale of the study is that by comparing the behavior of the existing vessel in the present channel with the proposed vessel in the proposed channel, it is possible to answer the questions being posed by this project.

23. The navigation maneuvers required to dock the tankers at the Chevron Long Wharf or to turn the containerships into the Richmond Harbor entrance channel allow many variations in pilot strategies. While the strategies may vary, different maneuvering commands can still result in a safe and successful transit of the ship.

24. Before presenting the analysis of the test results, it is necessary to explain the nomenclature used in presenting the results. The following abbreviations are used in this chapter as well as in Appendix A.

- a. Existing conditions - base test - BT
- b. Proposed conditions - deep test - DT
- c. Flood tide - FT
- d. Ebb tide - ET
- e. 87-kdwt tanker, partial ballast - 87PB
- f. 150-kdwt tanker, partial ballast - 150K
- g. Pilot X, repetition N - XN

25. Results with respect to the tankers were analyzed by comparing the base tests and the deep tests for any one pilot. Although an analysis between pilots is possible, it is felt that a comparison (BT to DT) of each pilot's strategies was a better comparison of the test results and defines the relative impact of the proposed channel.

26. Test results of the containership tests were analyzed as one group of tests. This procedure was used instead of the "within pilot" comparisons for the following reasons:

- a. No base test trials were simulated.
- b. Only two pilots were used in the testing.
- c. Not more than three repetitions were made for each test condition.

27. Table 4 gives the inbound navigation requirements for a successful ship transit; i.e. ship course, crosscurrent set, and required change of course. This information is presented so the reader can refer to the various values of these parameters when analyzing the data presented later in the report. It should be pointed out that the combination of current sets of 40 deg, required turns of 150 deg, and right then left turns in an area as limited as the Long Wharf maneuvering area requires special consideration when piloting these large vessels.

Table 4
Inbound Navigation Requirements

Navigation Area	Flood Tide				Ebb Tide			
	Ship Course deg	Current Direction, deg	Current Set deg	Change of Course	Ship Course deg	Current Direction, deg	Current Set deg	Change of Course
Southampton Shoal Channel	352	320	32-L	--	352	175	3-L	--
Long Wharf Dock	144	320	4-R	152-R	324	175	31-L	62-R 90-L
Richmond Harbor Entrance Channel	132	320	8-L	140-R	132	175	43-R	140-R

28. Selected test results are presented and discussed to illustrate the type of information generated and the methodology used in analyzing the data. The discussions presented consist of comparisons of the 87-kdwt tanker tests with the 150-kdwt tanker tests as well as three sets of results from the containership tests. The configurations of the tests presented in this part are:

- a. Tankers - flood tide - Pilot A
- b. Tankers - ebb tide - Pilot B
- c. Tankers - flood tide - Pilot C
- d. Tankers - ebb tide - Pilot C
- e. 638-ft containership - ebb tide - Pilot B

f. 810-ft containership - flood tide - Pilot B

g. 810-ft containership - ebb tide - Pilot B

Table 5 provides a complete list of all tests run during the study. Full data sets for each of these tests are presented in Appendix A in the same order as the tests are listed in Table 5. The study conclusions (based on a detailed analysis of all of the tests) are presented in PART V.

Table 5
Successful Trials Used for Analysis

<u>Pilot</u>	<u>Ship</u>	<u>Base Test</u>	<u>Deep Test</u>	<u>Flood Tide</u>	<u>Ebb Tide</u>	<u>No. of Trials</u>
A	87PB	X		X		4
A	150K		X	X		4
B	87PB	X		X		4
B	150K		X	X		4
C	87PB	X		X		2
C	150K		X	X		2
B	87PB	X			X	4
B	150K		X		X	4
C	87PB	X			X	1
C	150K		X		X	1
A	810-ft containership		X	X		2
B	810-ft containership		X	X		2
A	810-ft containership		X		X	3
B	810-ft containership		X		X	3
B	638-ft containership		X		X	1

Figure 10 shows the general paths the pilots follow in order to dock the tankers at the Chevron Long Wharf. It is emphasized that these are only typical paths and deviations may be readily accepted if the ships remain in the maneuvering area. The paths will vary as a function of the ship size; the

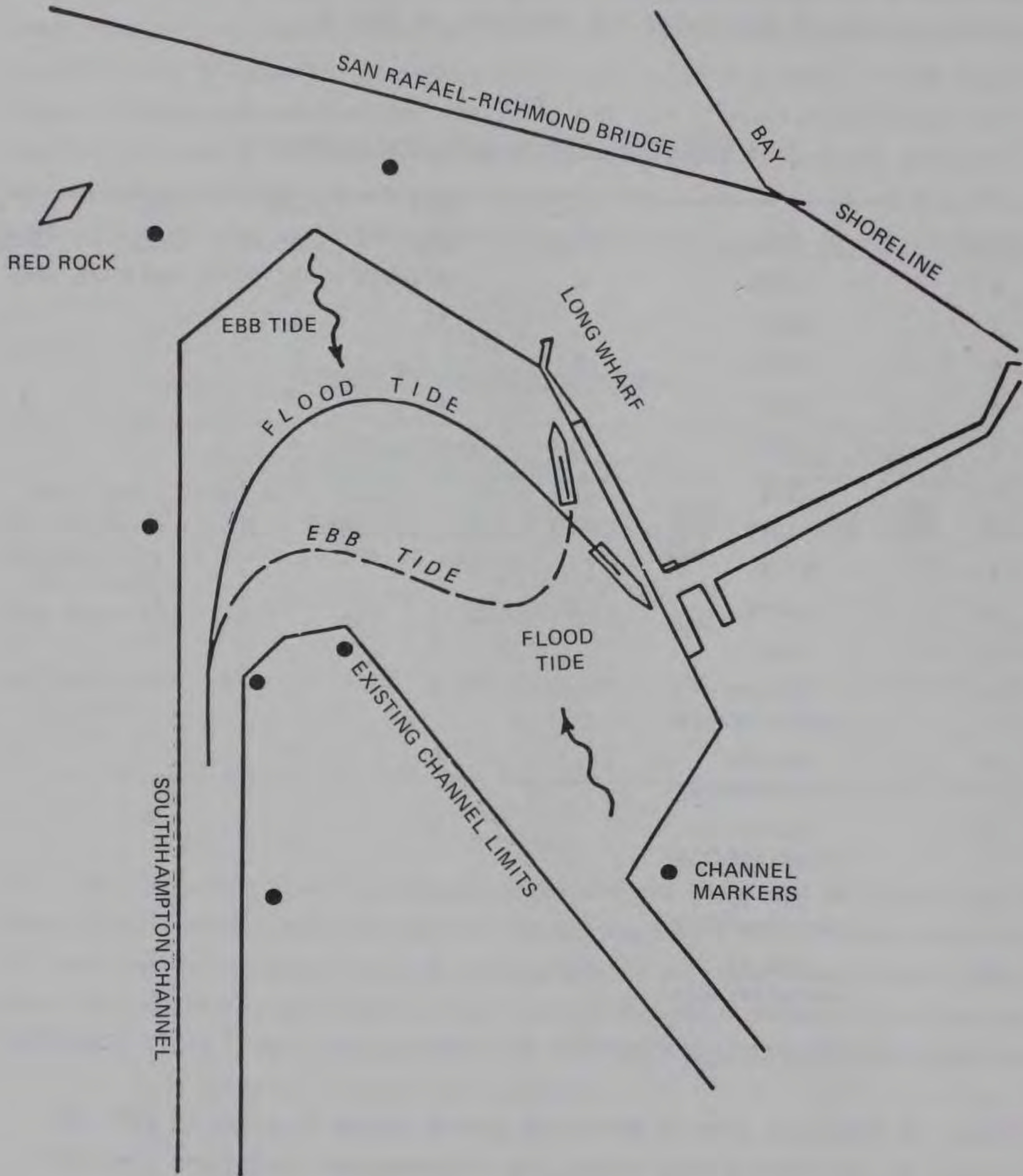

Figure 10. Pilot inbound, maneuvering strategy

test runs showed that the bow of the 150-kdwt tanker in the ebb tide situation could not be pointed as far south as the bow of the 87-kdwt tanker and still reach an acceptable docking posture. It was also found that the tanker's forward speed had to be reduced to 5 knots or less before starting a "kick-turn" (see paragraph 34 for definition), otherwise control of a safe vessel speed could not be maintained.

30. Figures 11-14 are a complete set of ship data comparisons for a tanker base test and deep test with flood tide conditions and Pilot A in control. Figure 11 shows plan views of the tankers' swept paths with respect to time: the greater the distance between the vessel outlines, the faster the vessel is traveling. A comparison of the two diagrams shows the 87-kdwt vessel traveling very high (i.e. farther north) in the maneuvering area, making the turn quite rapidly, and approaching the Long Wharf with very little lateral motion. Conversely, results from the 150-kdwt tanker simulation show that the turn is initiated much sooner and that the larger tanker is unable to make as sharp a turn. As a result, the larger tanker approaches the Long Wharf at a smaller angle so that the tanker is "crabbing" or having a large "drift angle" attitude (approximately equal axial and lateral ship motions). This maneuver is quite safe and is considered to be an acceptable procedure.

31. Figure 11 also shows both vessels crabbing to the right in the Southampton Channel. This crabbing compensates for the flood tide current angle to the channel. The crabbing angle experienced in this reach of the channel (15 deg with the 87-kdwt tanker) resulted in a maximum swept path of approximately 320 ft. This result will have an impact on the width of the Southampton Channel required for safe tanker navigation.

32. Figure 12 (for the same test) presents plots of distance along ship track plotted against rudder setting, engine rpm, distance off track, and ship speed for the two different vessels. The distance along track and distance off track represent values relative to the average track lines shown in Figure 15 (page 32). The path which each individual pilot will make may deviate from these average paths; therefore the plotted distance off-track values should only be used as a relative locator from the average track lines.

33. Each plot has a horizontal line representing zero on the vertical axis. This line has a small circle on it representing the position at which the vessel would reach the end of Southampton Channel and begin entering the Long Wharf maneuvering area. The circle for the deep tests is located about

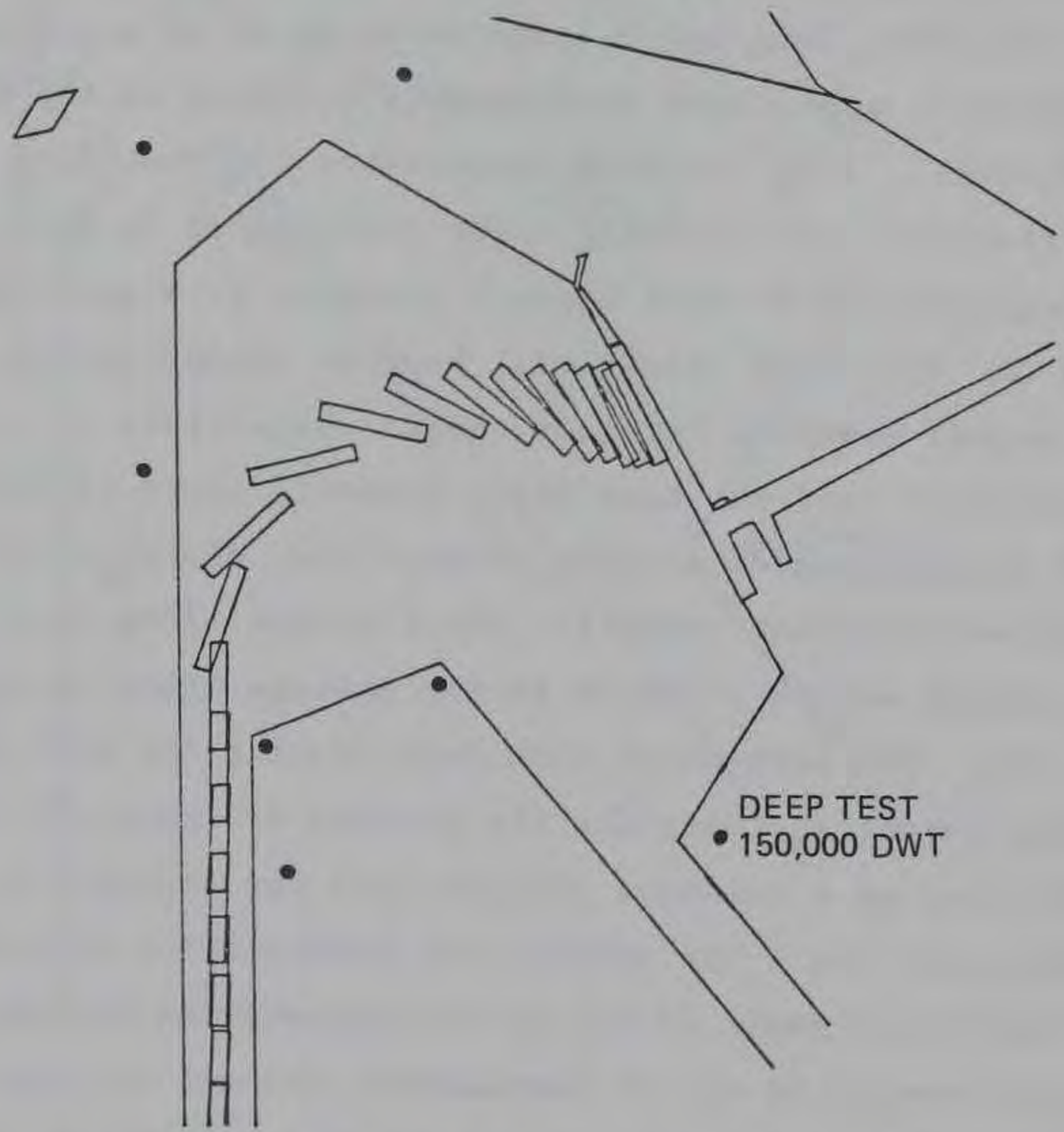
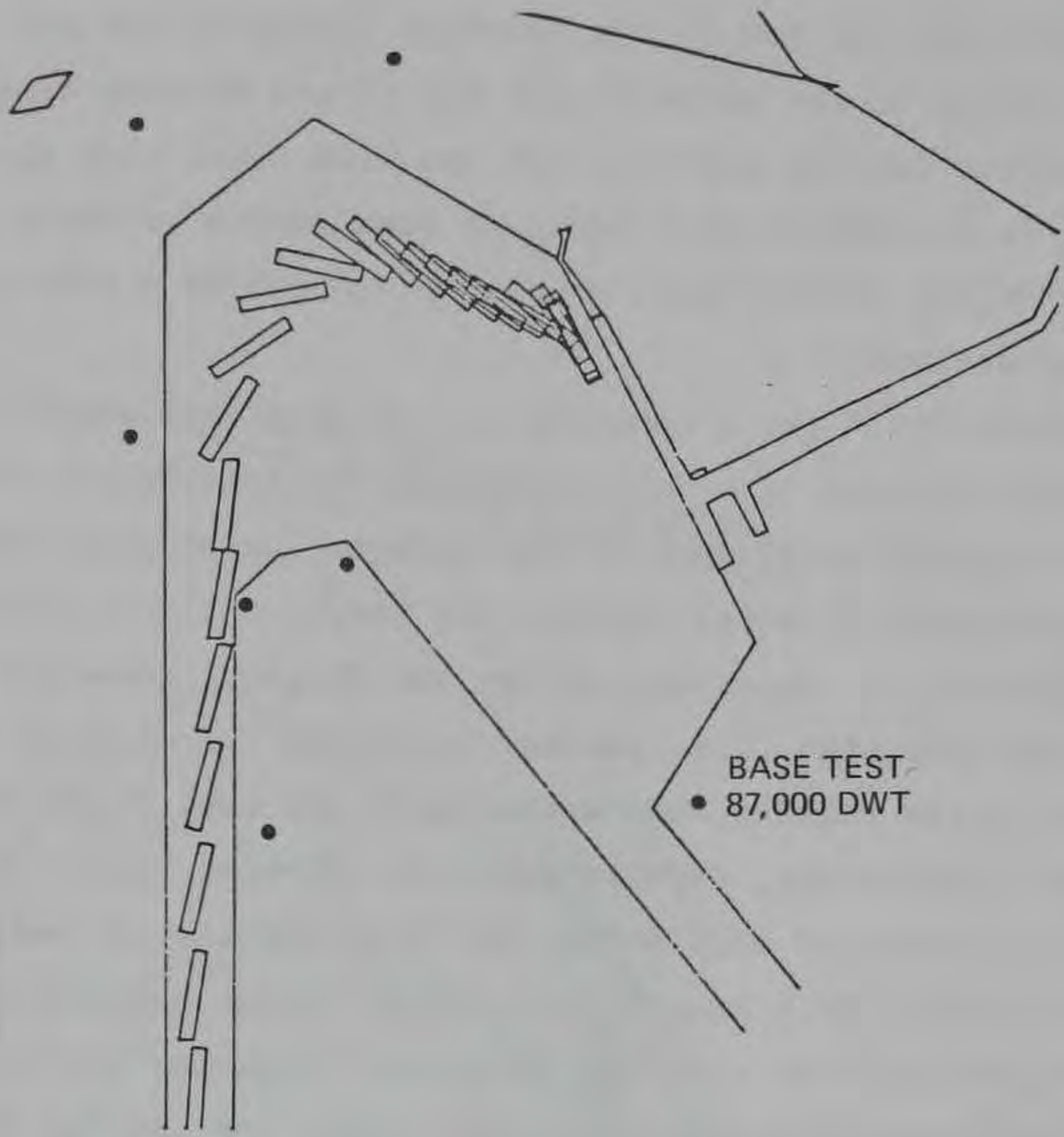

Figure 11. Ship tracks, flood tide, Pilot A

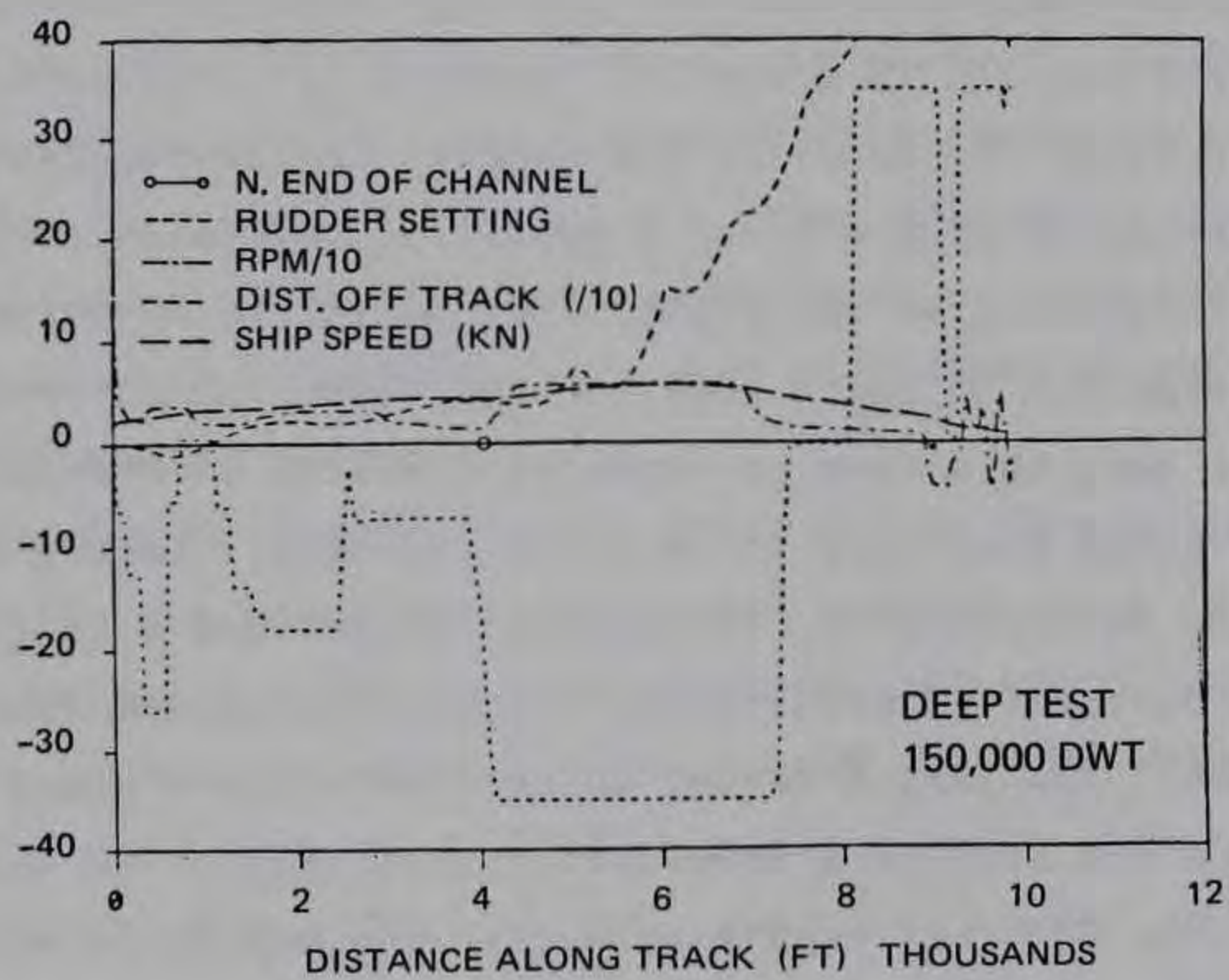
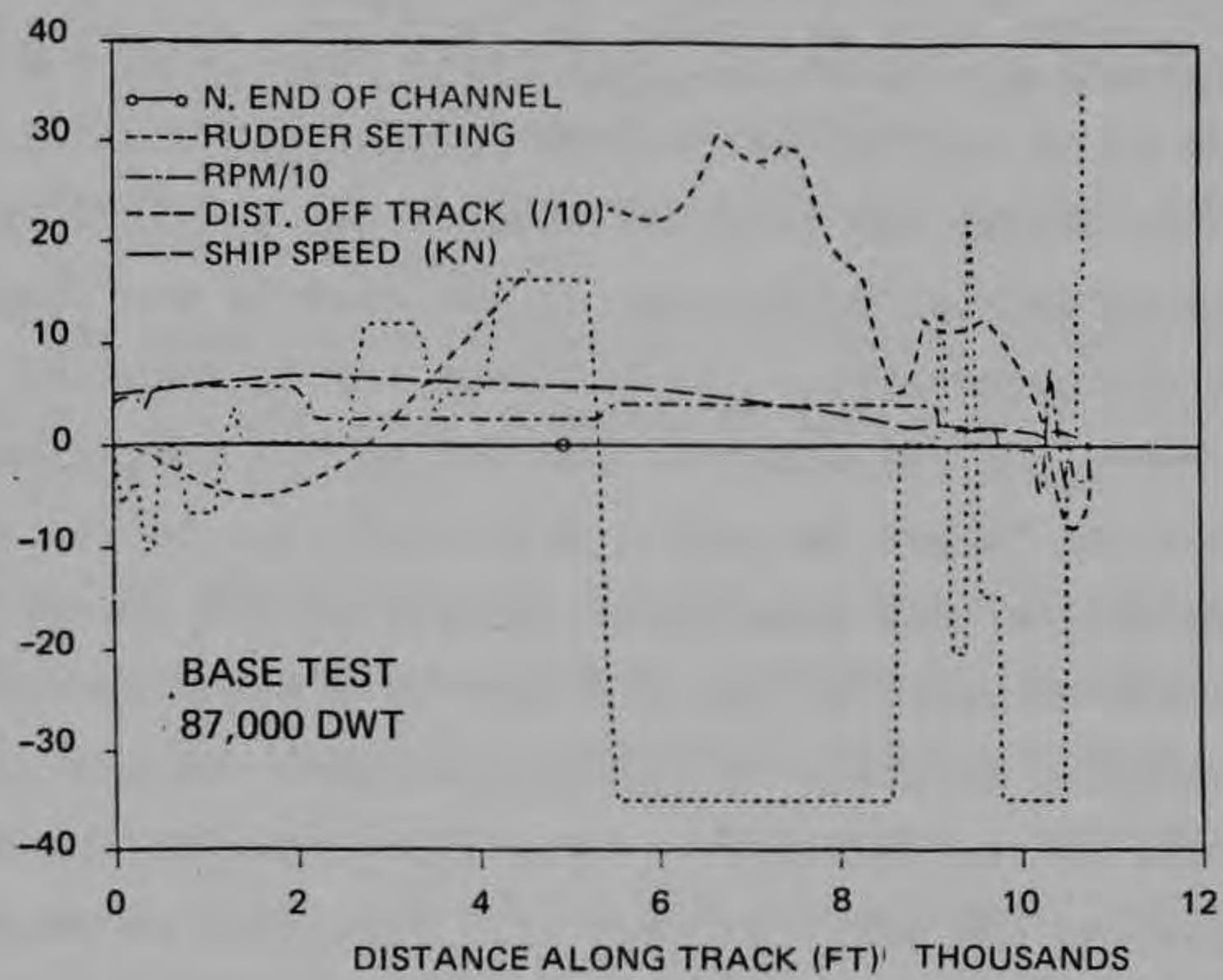

Figure 12. Maneuvering data, flood tide, Pilot A

1,000 ft prior to that of the base tests due to the proposed change in the geometry (plan view) of the channel/turning basin. As an example, notice the change in the "nose" of the turning area in Figure 15 (page 32).

34. Referring to Figure 12, both tests have large rudder settings for the first 1,000 ft of the transit in the Southampton Channel. This is due to the fact that the vessel was initially positioned parallel to the heading of the channel and an initial adjustment of the heading was required to compensate for the crosscurrents. The 150-kdwt tanker required larger rudder settings to achieve the compensation because of its larger mass, lower initial rpm setting, and its larger projected area available to the currents. Near the entrance to the turning area (small circle on the graph), notice the combination of the increase in rpm with the full right rudder. It is useful to analyze the rudder settings in combination with the rpm settings because the effectiveness of the rudder is a strong function of how much water the propeller is pushing (or pulling) past it. This type of maneuver is referred to as a "kick-turn" by pilots. Its purpose is to achieve a quick increase in the rate of rotation of the vessel without a great deal of increase in speed. The larger rudder angle provides the turning action as well as acting as a significant drag force. This type of maneuver is repeated near the track distance of about 9,000 ft; however, the concept is the reverse. A full left rudder in combination with a reverse propeller will also result in an increase in the rate of rotation to the right. One advantage of this method is that the reverse propeller helps in lowering the vessel speed; however, it should be pointed out that this type of maneuver (reverse kick-turn) is not as effective as an ahead kick-turn in rotating the ship. Lastly in Figure 12, the ship speeds can be evaluated. The smaller vessel had a larger ship speed until a track distance of about 9,000 ft where it slowed down to about 2 knots and then 1 knot. The larger vessel maintained a lower speed throughout the entire test and was much less responsive (with respect to speed) to the kick-turn. The reason for this behavior is that the vessel is much more difficult to accelerate and decelerate due to its larger mass.

35. The plots on the last 2,000 ft of Figure 12 were invariably very difficult to interpret. Because this was an important area to analyze the behavior of the vessel, the "docking posture" of the vessels was analyzed in more detail. Figure 16 (page 33) is a definition sketch of the docking parameters which were believed to be of significant importance. Criteria with

respect to the proper docking posture were developed to be used as a guide and are listed below:

- a. The distance from the vessel to the wharf should not be less than one length of the ship. At this point, the vessel is no longer under its own power and the tugboats would perform the remainder of the docking procedures.
- b. The angle between the wharf and the vessel should be no greater than about 15 deg.
- c. The axial speed of the vessel should be less than 1 knot.
- d. The bow and stern transverse speeds of the vessel should be less than 1 fps.

36. Figure 13 represents the docking speeds (for the same test as analyzed above) of the two ships as they approached the Long Wharf. Due to the large drift angles experienced with the 150-kdwt tanker, the speeds were broken down into three components; i.e. axial speed, transverse bow speed, and transverse stern speed. Negative transverse speeds represent movement of that portion of the vessel to the left (with respect to the vessel) and positive to the right. Negative axial speeds represent the movement of the vessel backward and positive speeds represent forward motion. When analyzing the transverse speeds, the rate of rotation of the vessel is represented by one transverse speed being greater than the other. A change in the direction of the rate of rotation occurs where the two lines intersect. If both transverse speeds (bow and stern) have the same algebraic sign, then both ends of the vessel are approaching or leaving the wharf regardless of the difference between the two speeds.

37. Referring to Figure 13, the pilot of the 87-kdwt tanker did a fine job of approaching the wharf with the tanker located about 400 ft away from the wharf when he began a turn. In a prototype situation, the tugs would have taken over here regardless of the distance away from the wharf. In this case, the test results show that the pilot commanded a quick kick-turn and moved the vessel closer to the dock under its own power. In comparison, the 150-kdwt vessel's axial speed was quite high (2.3 knots) approximately 750 ft away from the wharf. At this point the pilot applied the reverse kick-turn and one can see the decrease in axial speed along with some increase in rotation. This was followed by an overcompensation for the reverse kick-turn which reversed the rotation; however, the speeds are sufficiently low and the docking posture is considered to be adequate.

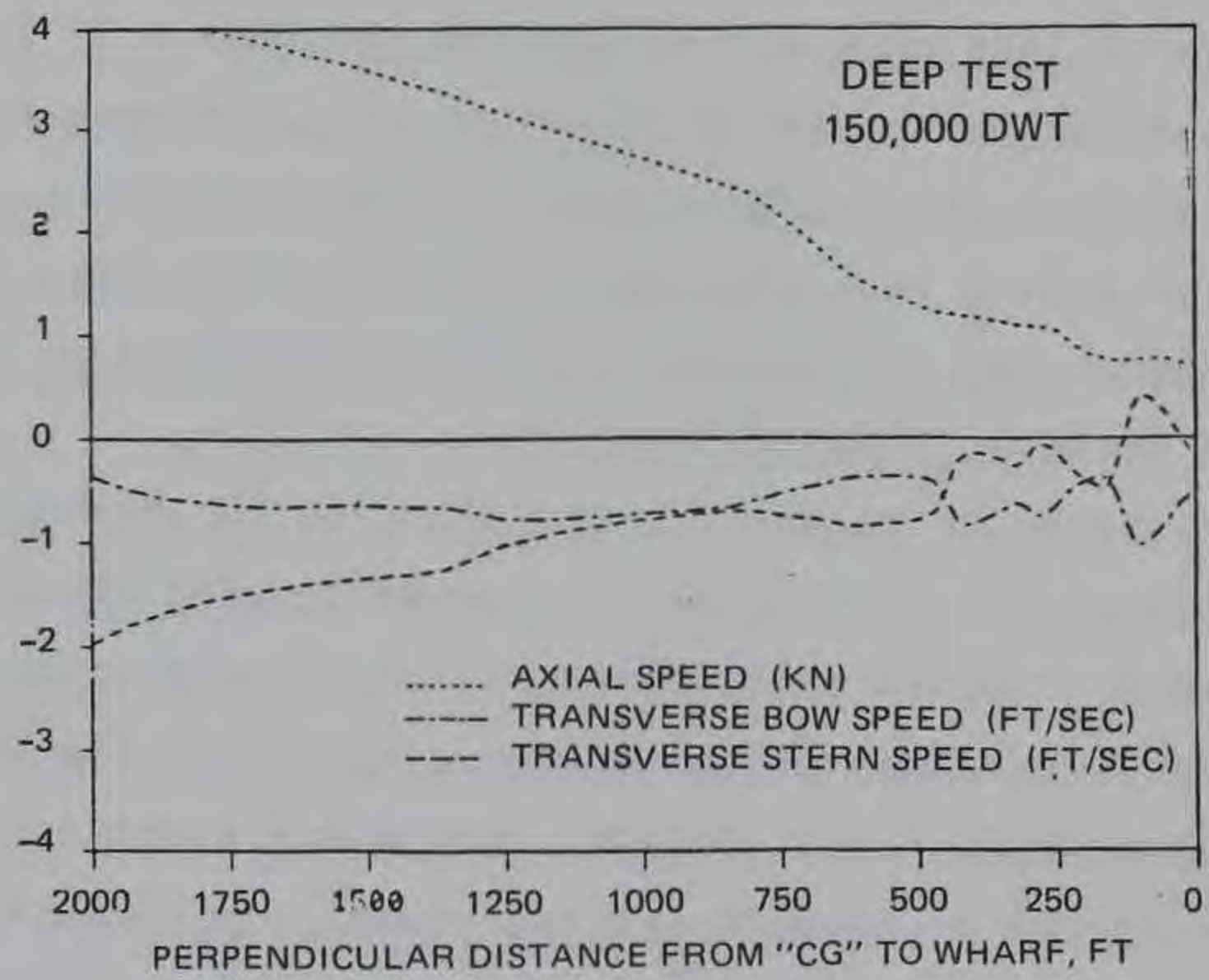
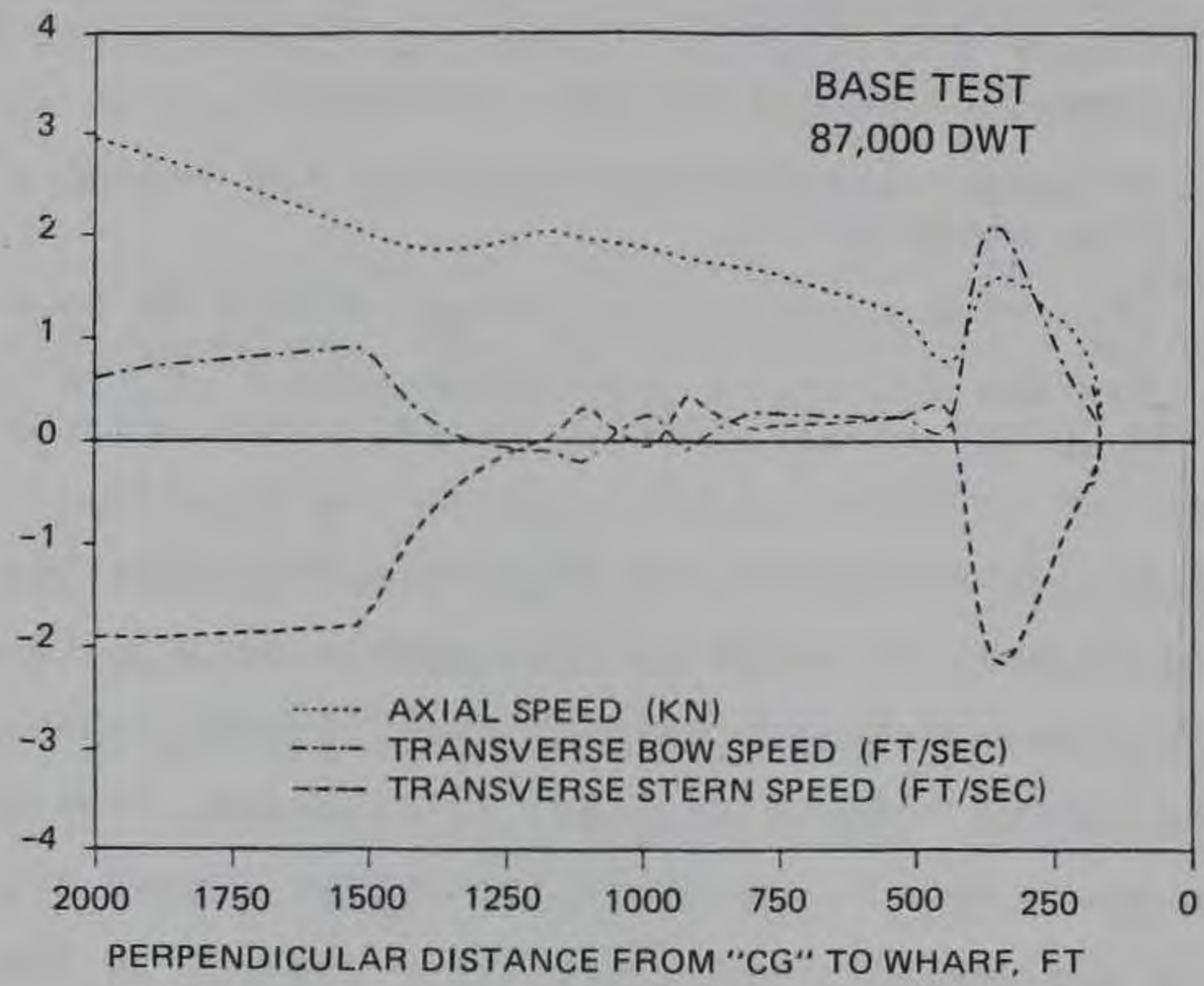

Figure 13. Docking speed, flood tide, Pilot A

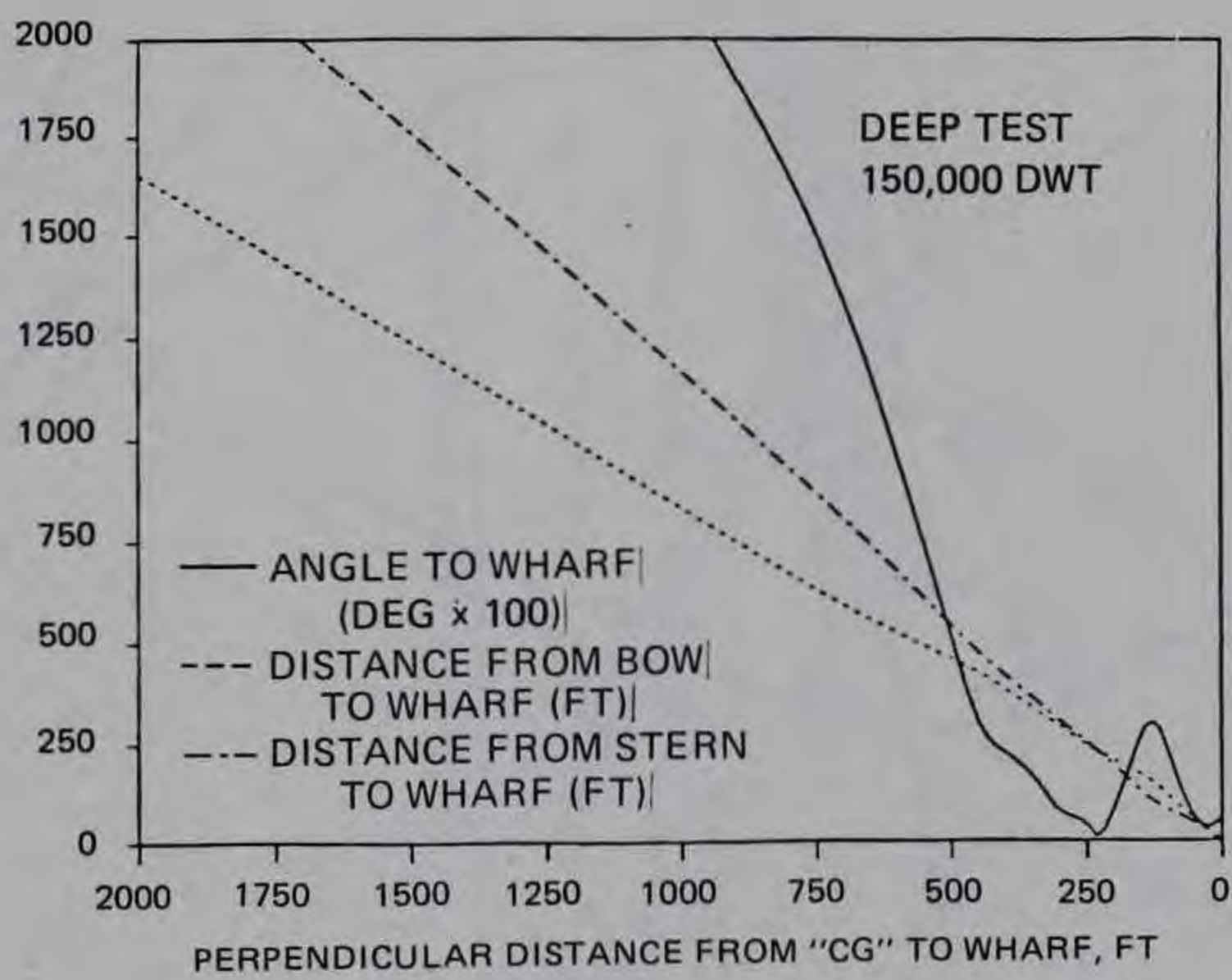
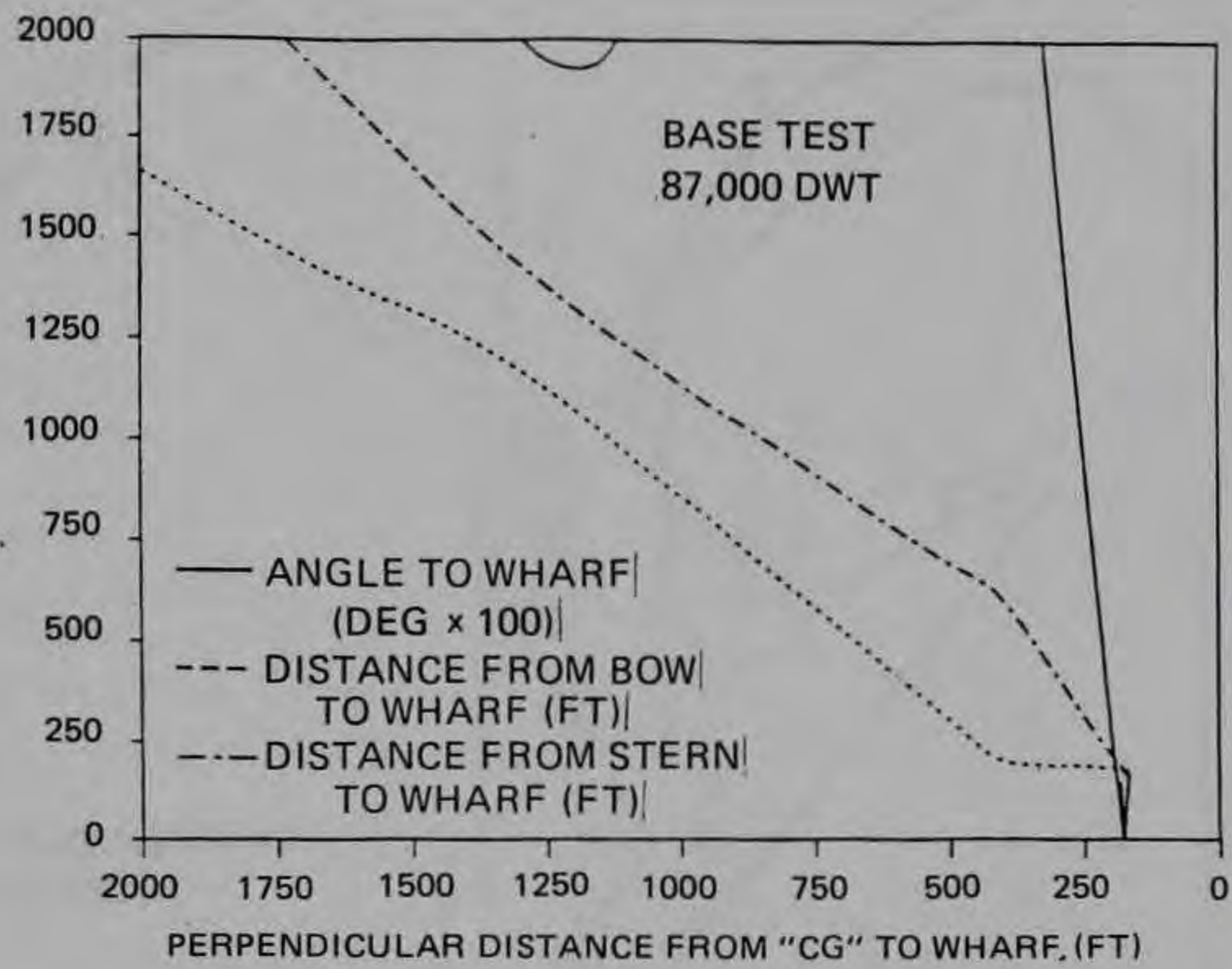

Figure 14. Docking posture, flood tide, Pilot A

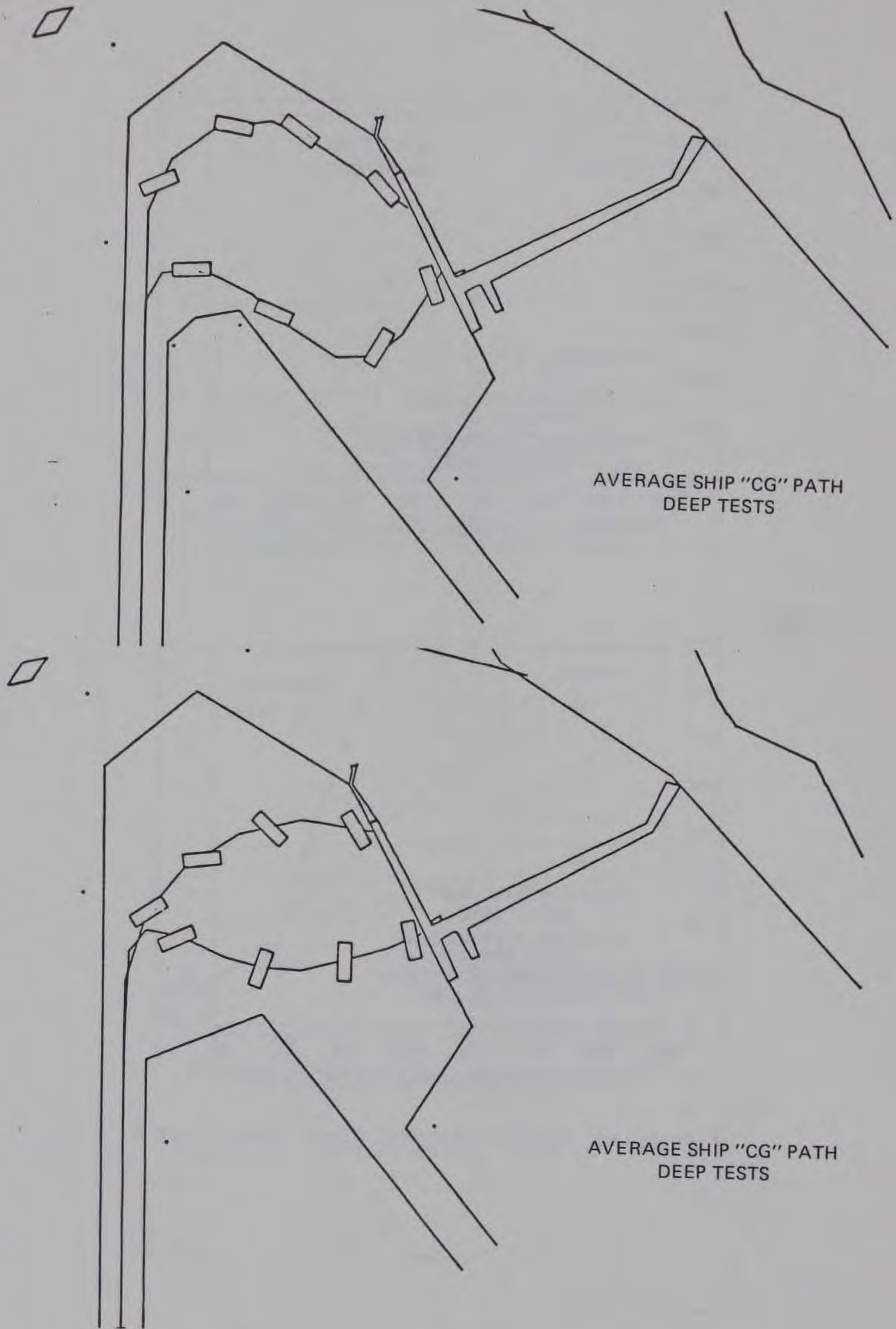

Figure 15. Average tanker paths

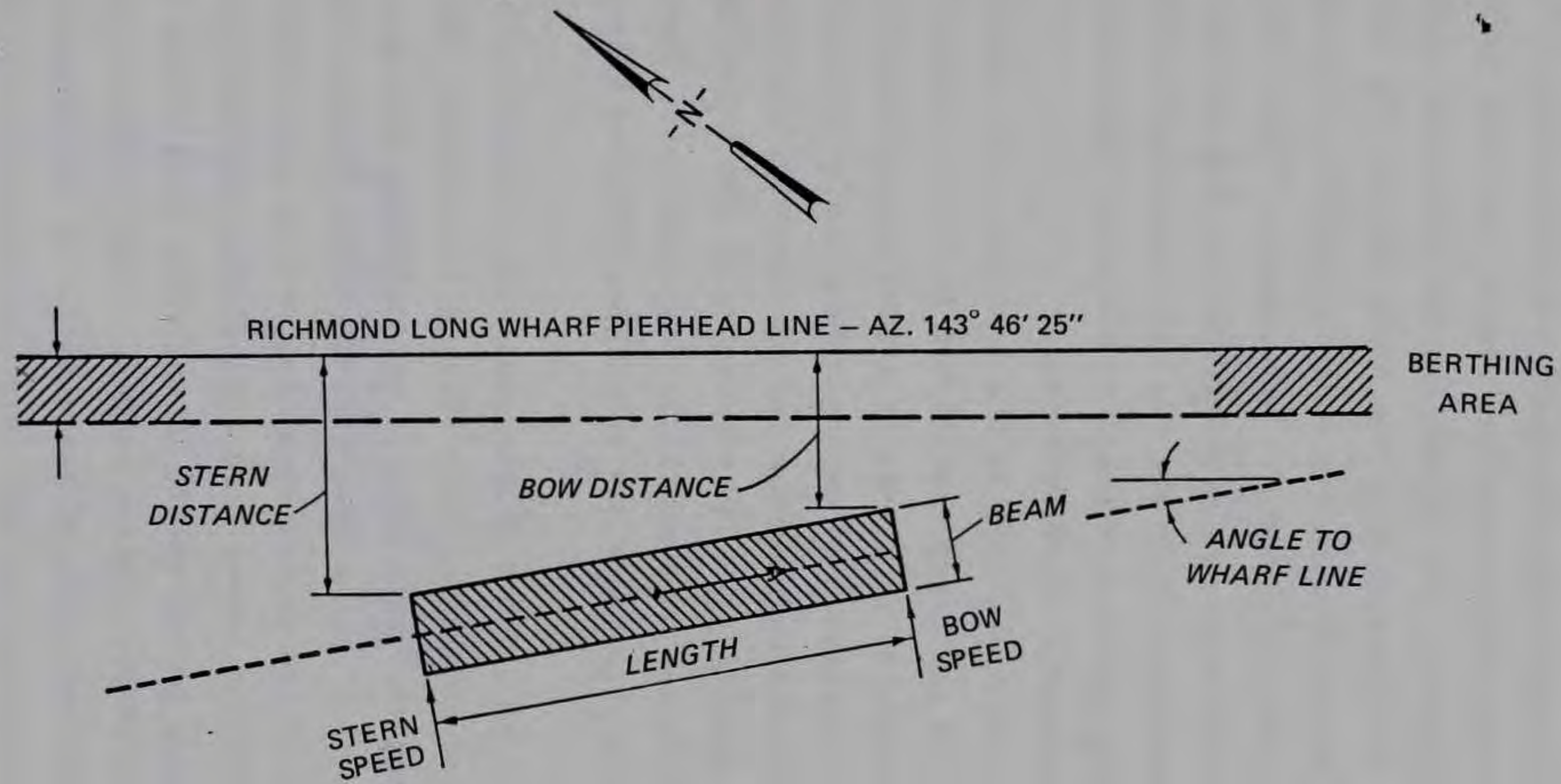

Figure 16. Ship docking posture, definition sketch

38. Figure 14 is used to analyze the physical posture of the vessel as it approaches the wharf. For these plots, the position and orientation of the vessel (relative to the wharf) are presented. These graphs are to the same scale for the horizontal axis as the graphs in Figure 13 so the overall speed/position at any point approaching the wharf can be analyzed. The more nearly parallel the bow and stern distance lines remain, the more uniform the vessel is in approaching the wharf. The closer the two lines are together, the more parallel the vessel is to the wharf. The angle between the vessel and the wharf will never be less than zero for when this occurs, the angle is measured from the back side of the wharf. Referring to Figure 14, Pilot A has done an excellent job of achieving a proper docking posture for both vessels. The 87-kdwt vessel managed to keep the approach angle more uniform than the 150-kdwt vessel. This can be attributed to the axial approach instead of the crabbed approach used by the 150-kdwt vessel.

39. Graphs of the types used in the previous four comparisons are available in Appendix A for every test listed in Table 5 (page 23). The previous explanation for the four sets of graphs described was used to show the results from one comparison of base and deep tests (flood tide), as well as to provide the reader a methodology for interpreting the other sets of graphs presented in Appendix A. The discussion of the following tanker tests does not include a full set of comparisons for each test. Instead, selected plots are presented to illustrate how strategies differed with pilots or test conditions.

40. Figures 17 and 18 are graphs comparing a set of tests for the two tankers under ebb tide conditions with Pilot B in control. Figure 17 shows both tankers beginning the right turn at approximately the same position in the maneuvering area. It can be seen that the larger tanker does less turning, resulting in the bow of the vessel remaining pointed more toward the wharf. If the bow of the 150-kdwt tanker were to move down farther than a position which was perpendicular to the wharf, it was found that it was impossible to bring it back up to a proper docking posture. This is due to the ebb tide currents acting on the left side of the vessel. It is obvious that the 87-kdwt tanker had no problem making the left turn into the currents and obtaining a proper docking posture. Figure 17 shows that both vessels' sterns came close to the bank near the nose of the maneuvering area. It was not necessary for the smaller vessel to hug the starboard bank in this area; however, the

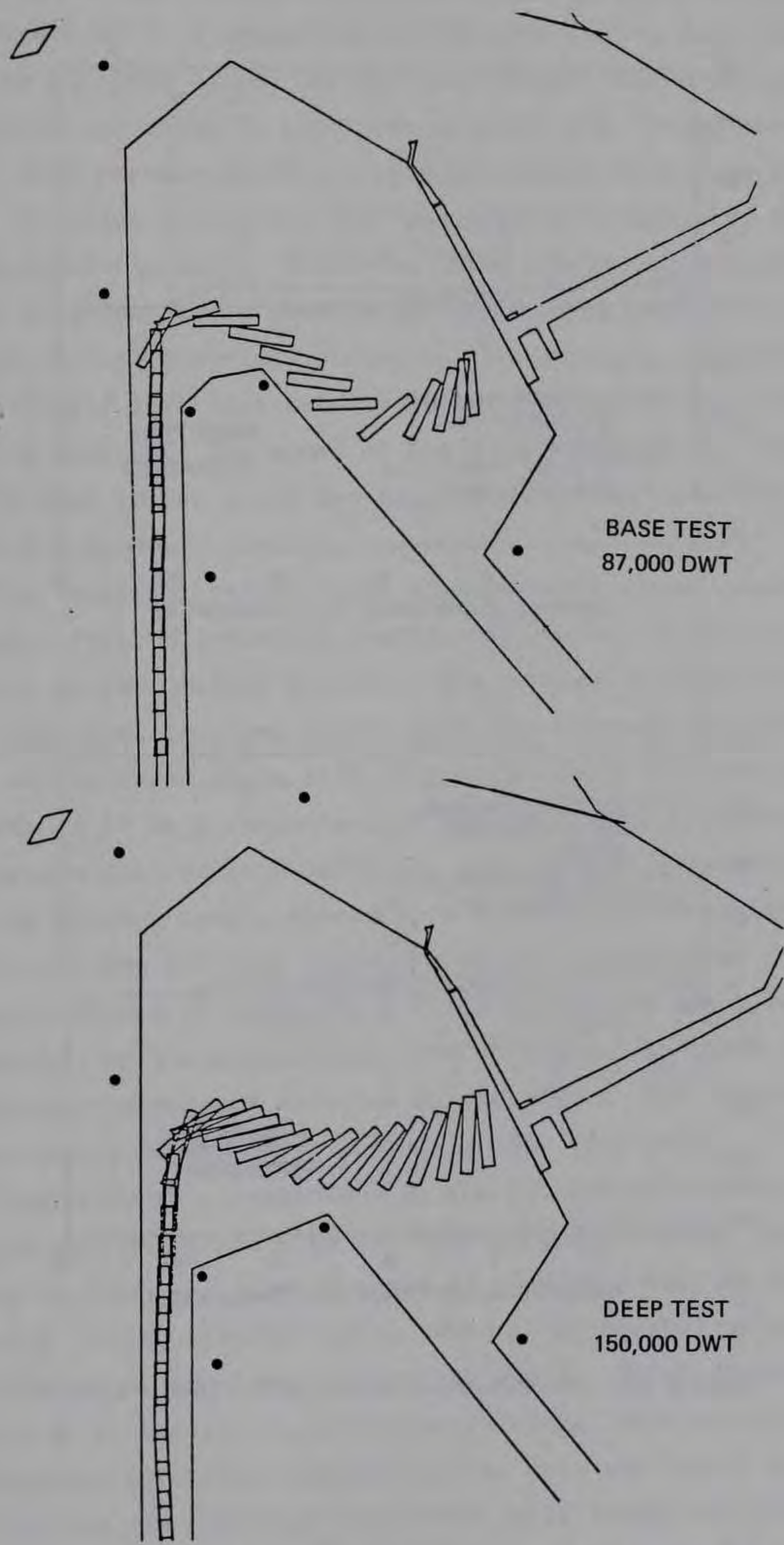

Figure 17. Ship tracks, ebb tide, Pilot B

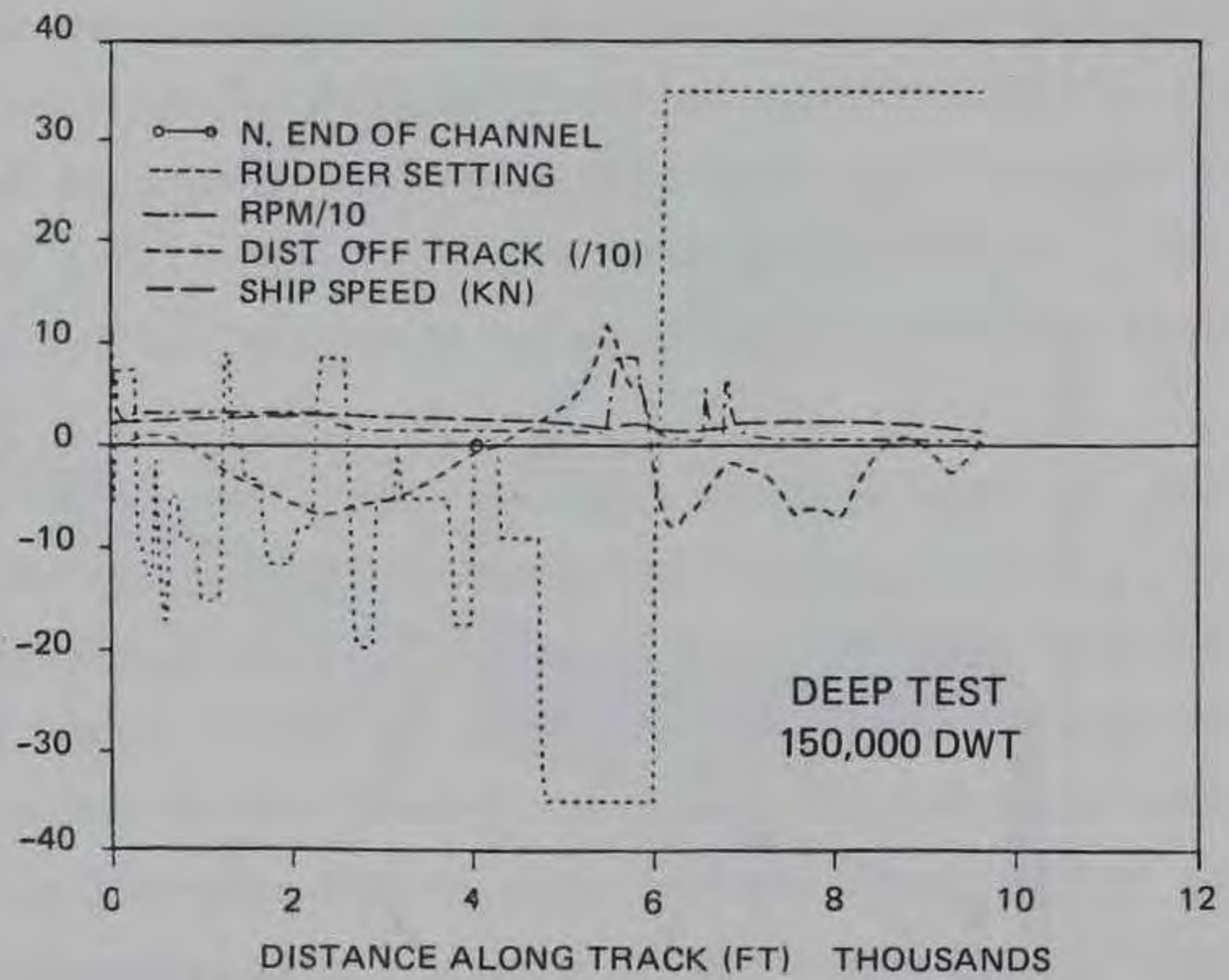
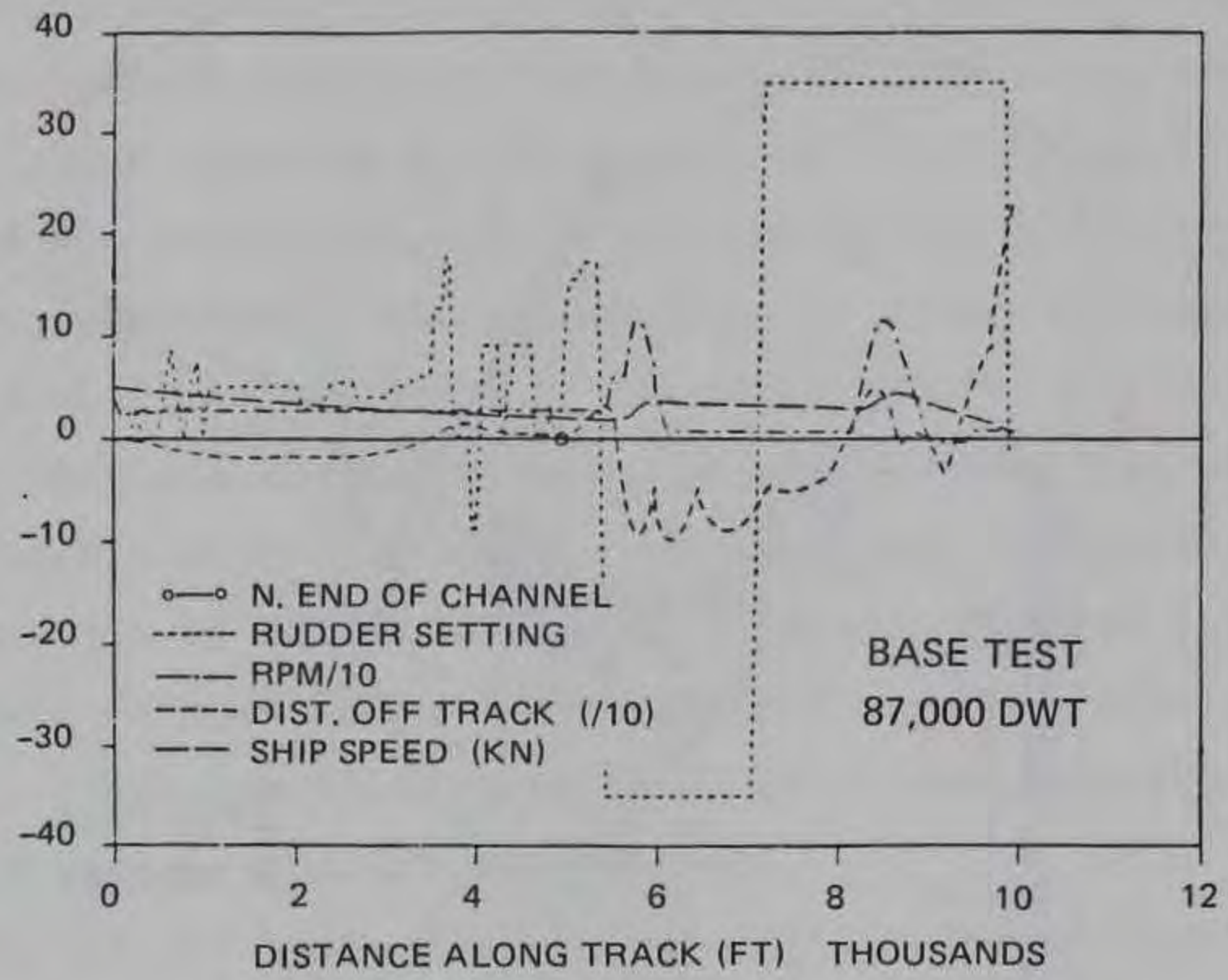

Figure 18. Maneuvering data, ebb tide, Pilot B

larger vessel needed some of the nose removed. It can be seen that some of the space is needed but not all of the recommended cutoff is required.

41. Figure 18 is a comparison of the maneuvering data for the same test as above. The 150-kdwt tanker has more and larger rudder activity in the reach of the channel prior to the turn; however, the 20-deg values are still acceptable. Both vessels perform a very pronounced kick-turn to initiate rotation to the right just after the opening from Southampton Channel into the Long Wharf maneuvering area. Following this, the 150-kdwt tanker has two very short bursts of propeller in combination with a left rudder to keep the bow of the vessel in an "up" position. Later in the sequence, the 87-kdwt tanker performs a stronger left kick-turn to rotate the bow of the vessel into a proper docking posture. The speed of the 87-kdwt tanker is about 4 or 5 knots while the 150-kdwt tanker makes the transit at a much slower and constant speed of about 2 knots.

42. The remaining tanker tests presented here were completed by a Chevron pilot. Pilot C tended to position the vessel a greater distance from the Long Wharf at the docking posture. His comment at that time was, "With the ship in this position, you can do anything you want with her." This represents one of the cases where different pilots have different strategies.

43. Figure 19 is a comparison of the two tanker transits with flood tide. It appears that Pilot C makes the same general maneuvers as Pilots A and B with the 87-kdwt tanker except with a more uniform radius turn; however, the maneuver with the 150-kdwt tanker shows no crabbing over to the wharf as Pilot A does in Figure 11 (page 26). Pilot C chose to use a reverse kick-turn near the entrance to the maneuvering area to reduce the speed of the vessel while increasing the rate of rotation to the right. The simulation test results show that this procedure proved to work very well.

44. Figure 20 is a comparison of the two tanker transits with ebb tide. Both transits were performed with the same general strategy in mind as that used by Pilot B; however, Pilot C tends to keep both vessels located higher (farther north) in the turning basin. This is acceptable unless it is desired to dock the vessel at the lower end of the wharf. Pilot B's strategy (Figure 17) would be considered to be the maneuvering limit to Pilot C's strategy. Pilot C's strategy (with both vessels) is to keep the bow of the vessel pointed upward and let the ebb tide push the vessel over toward the wharf. In time, the 87-kdwt tanker would have drifted closer to the wharf due to the ebb tide.

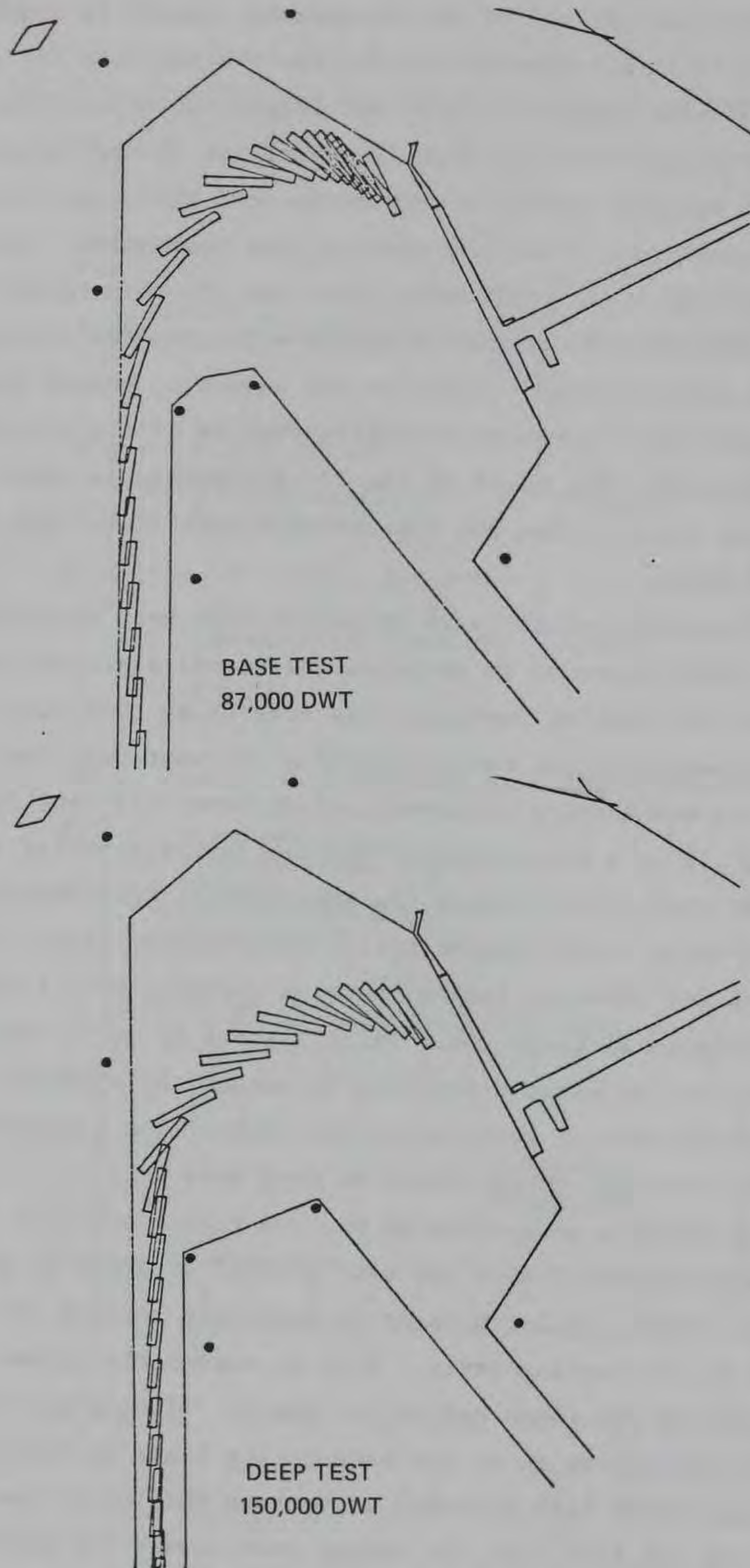

Figure 19. Ship tracks, flood tide, Pilot C

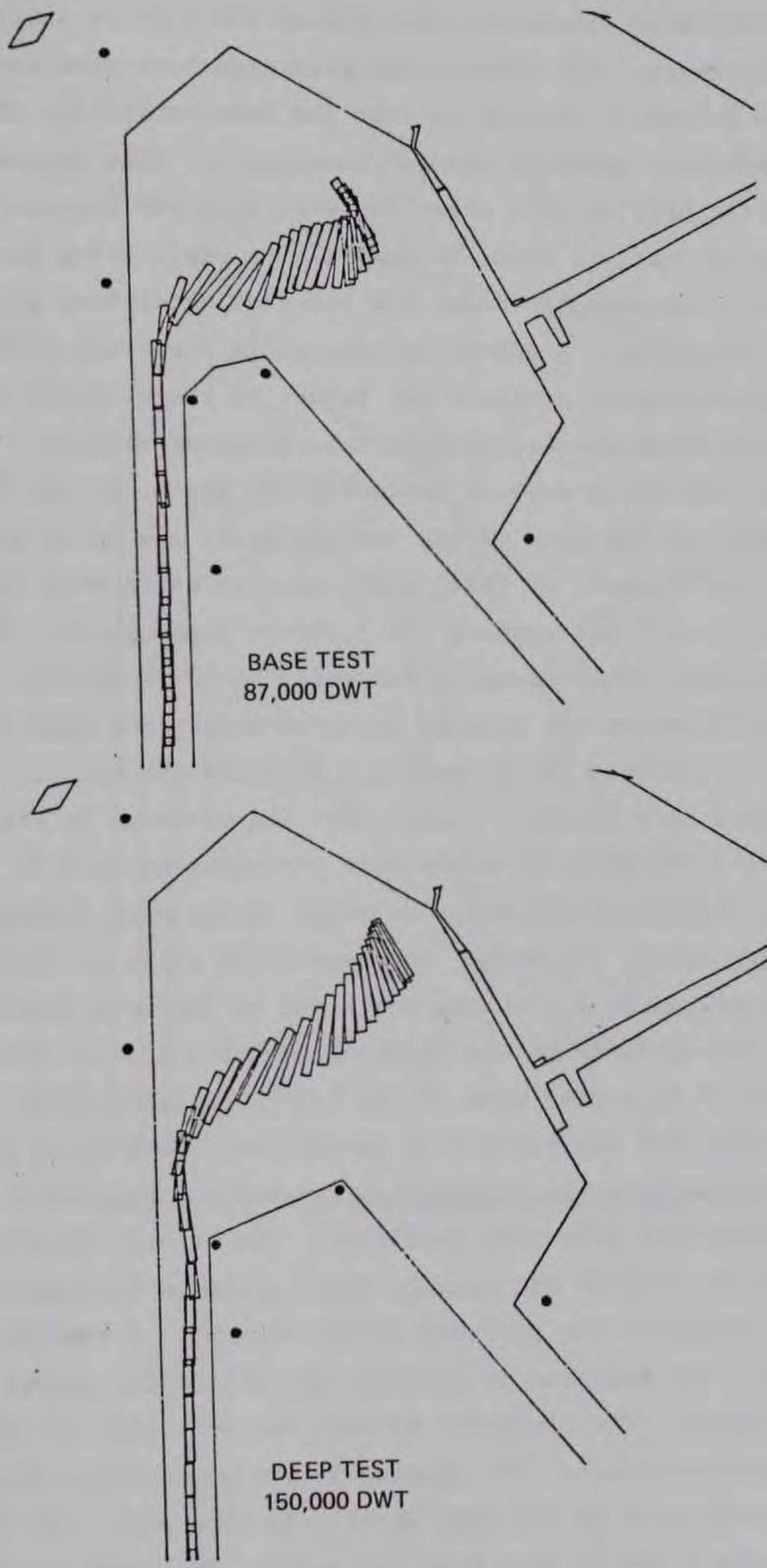

Figure 20. Ship tracks, ebb tide, Pilot C

Both tests shown in Figure 20 would be considered successful transits.

45. The following discussion illustrates the type of analysis used for the containership tests. All three tests presented here were conducted by Pilot B. It was initially decided to test the maneuverability of an 810-ft containership under the proposed project conditions. This containership is not presently being used in this area; however, with the proposed Richmond Harbor deepening project, it would be feasible to begin using such a vessel. The larger 810-ft containership under the ebb tide conditions proved to be very difficult to control. A 638-ft containership presently being used in the area was also tested to evaluate the impact of the proposed channel deepening on present-day containership traffic into Richmond Harbor.

46. After completing several containership tests, it was found that the proposed cutoff of the nose of the turning basin was of no benefit to the containerships. As a result of this, containership tests were run for the deep test depths (45 ft) but without the 1,000-ft nose cutoff. Therefore both the base test and deep test nomenclatures refer to 45-ft depths.

47. Figure 21 shows the general containership paths that were used to plot the values of distance along track and distance off track. The paths should only be used as a relative locator for the vessel. In Figure 22, three small circles are plotted on the line representing zero on the vertical axis. The first represents the point at which Southampton Channel meets the Long Wharf turning basin, the second represents the point at which the vessel would be located perpendicular to the north end of the Long Wharf, and the last represents the entrance to the Richmond Harbor entrance channel.

48. Figure 22 is a plan view of the 810-ft containership's transit with the maneuvering data for the flood tide conditions. Once again a large crabbing angle is necessary in the Southampton Channel to compensate for the cross-currents experienced for this tide condition. The transit required a right kick-turn around the nose of the turning basin followed by a smaller left kick-turn to line up and enter the Richmond Harbor channel. A considerable amount of rudder activity was required to maintain control of the vessel during the flood tide conditions. The clearance between the left side of the vessel and the left bank (port clearance) was plotted in the maneuvering data to analyze how close the vessel came to the Long Wharf. In this case, the vessel was always greater than 1,000 ft away from the wharf. The speed of the vessel was very much influenced by the kick-turns (reaching a maximum of 8 knots);

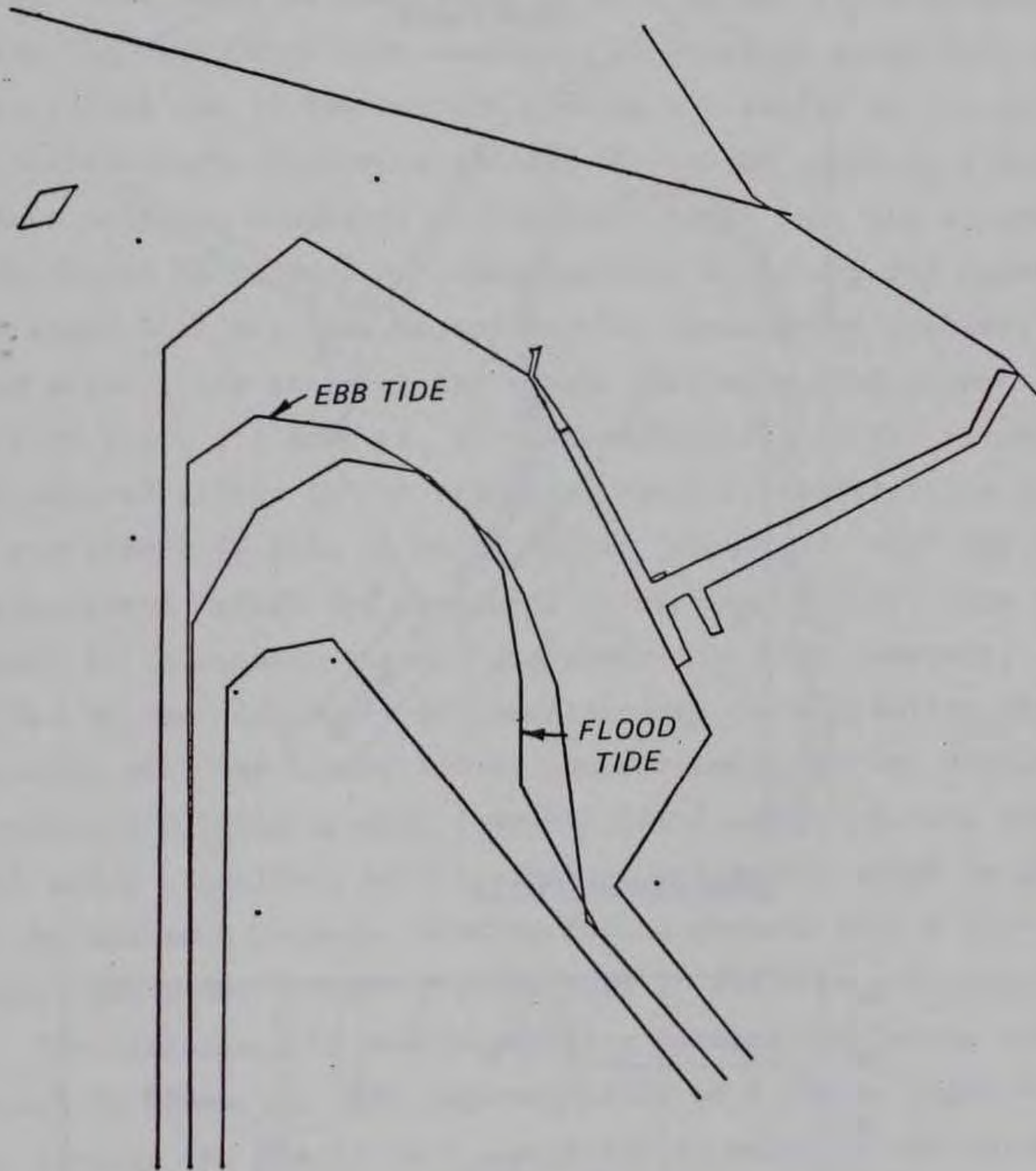
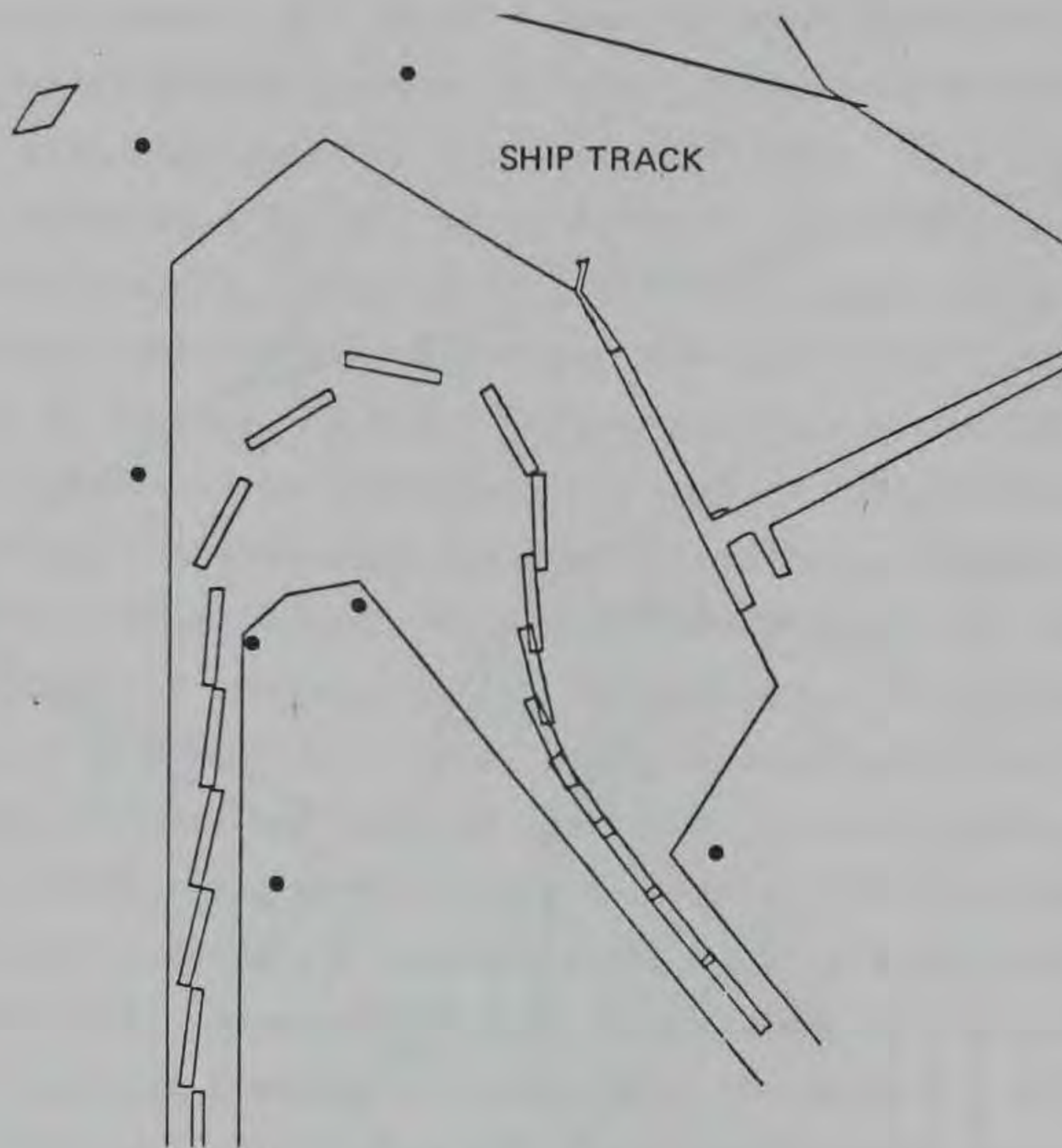

Figure 21. General containership paths



MANEUVERING DATA

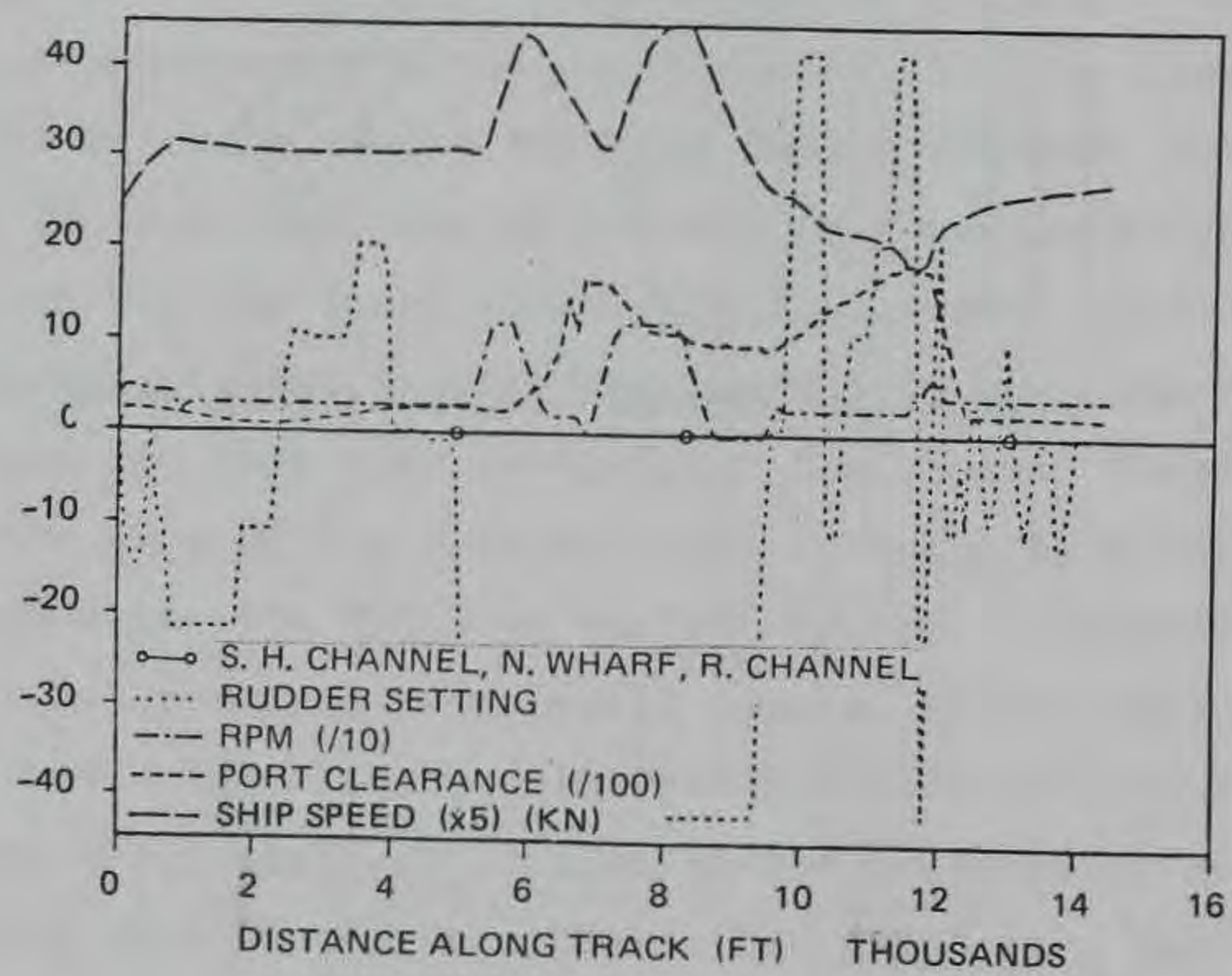

Figure 22. 810-ft containership test, flood tide, Pilot B

however, the speed did decrease and stabilize following the kick-turns as the vessel headed into the currents. This would be considered to be a safe maneuver.

49. Figure 23 is the best test with the 810-ft containership with ebb tide, and even this would be considered to be a marginally safe maneuver. The response from the right kick-turn caused an increase in speed that was very difficult to reduce due to the current pushing the vessel in the direction of travel. A reverse right kick-turn reduced the vessel speed to a point where a left kick-turn could be completed to line the vessel into the Richmond Harbor channel. It should be pointed out that the left kick-turn did cause another increase in speed that may have caused further maneuvering problems outside of the study area. This maneuver did result in a safe minimum port clearance at the wharf of 1,000 ft; however, the controllability of the vessel is in question at several points in the transit. Further investigation into bringing the 810-ft containership into Richmond Harbor (especially with the ebb tide) should be considered before the deepening of Richmond Harbor. One other possibility would be to require tugboat assistance for this maneuver.

50. Due to the difficulty of containership control during ebb tide inbound transits with the larger 810-ft containership, it was decided to study the proposed Baldwin project (essentially a deeper channel and maneuvering area) using a smaller, more typical containership which is presently calling at the Richmond Harbor. Results from a transit with a 638-ft containership (ebb tide) presently being used in the area are plotted in Figure 24. The difference in maneuverability between the larger and this smaller vessel is dramatic. The implementation of a simple right kick-turn resulted in turning the vessel into a position in which it was perfectly lined up to enter the Richmond Harbor channel with an excess of time and distance to slow the vessel to a safe entrance speed. At the same time, the minimum port clearance at the wharf was approximately 2,000 ft.

51. The following comments are an overview of all the tests with saved data on the computer discs and as presented in Appendix A. The order in which the tests are given in Appendix A is the order in which they are listed in Table 5 (page 23).

52. During flood tide transits, the larger 150-kdwt tanker always required more crabbing near the wharf than did the smaller 87-kdwt tanker which tended to approach the wharf from the north in a direction along the wharf

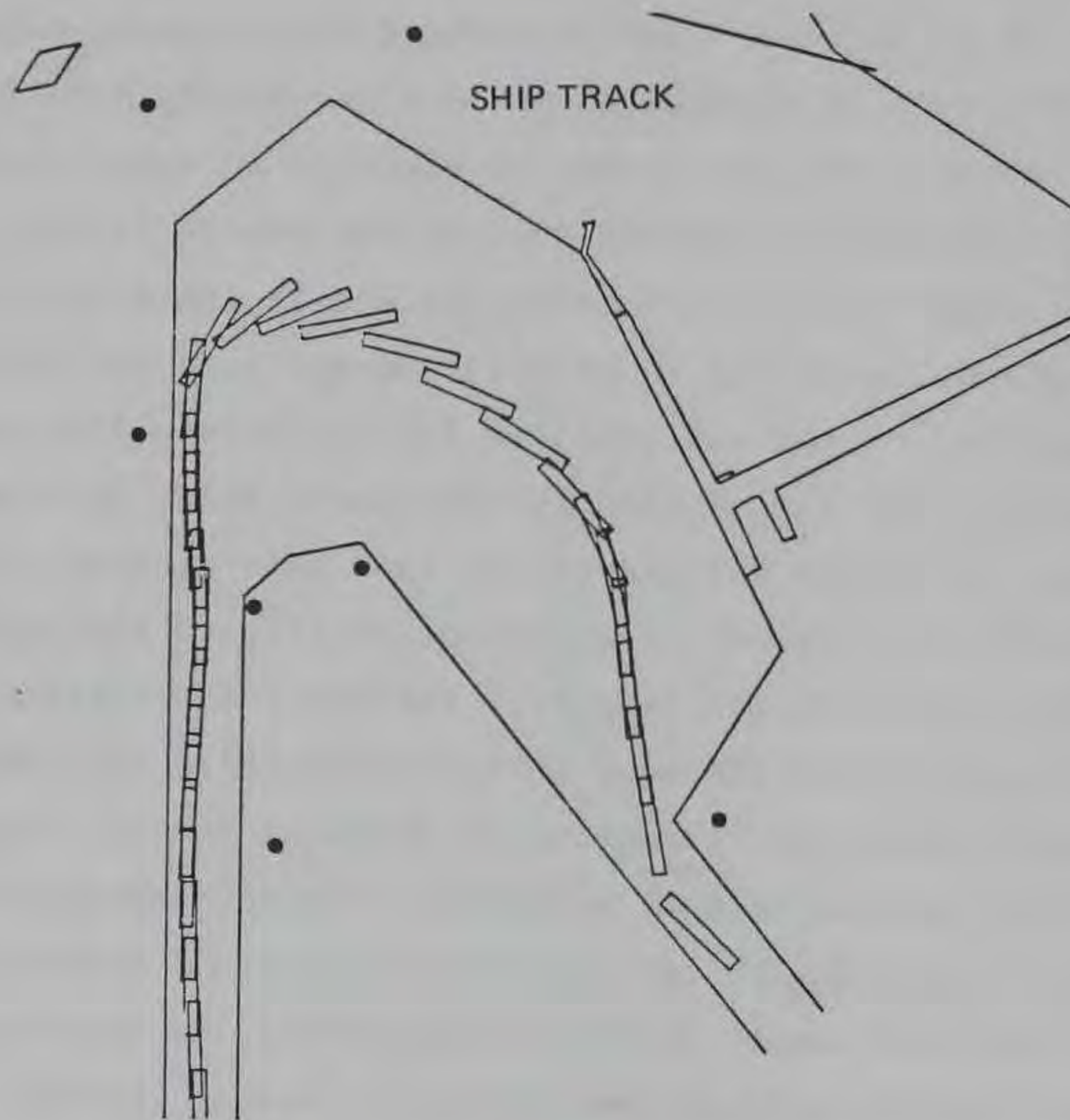

MANEUVERING
DATA

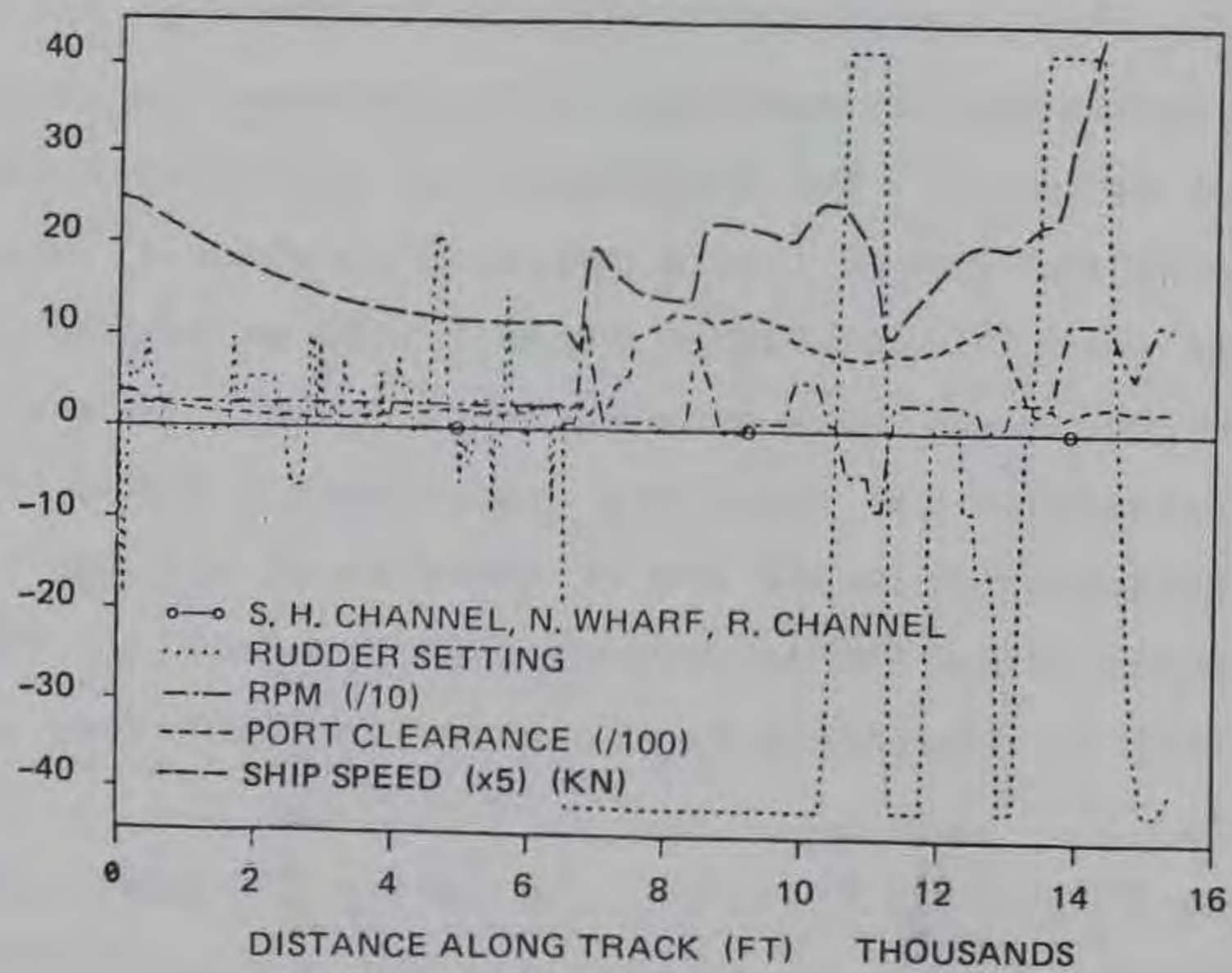

Figure 23. 810-ft containership test, ebb tide, Pilot B

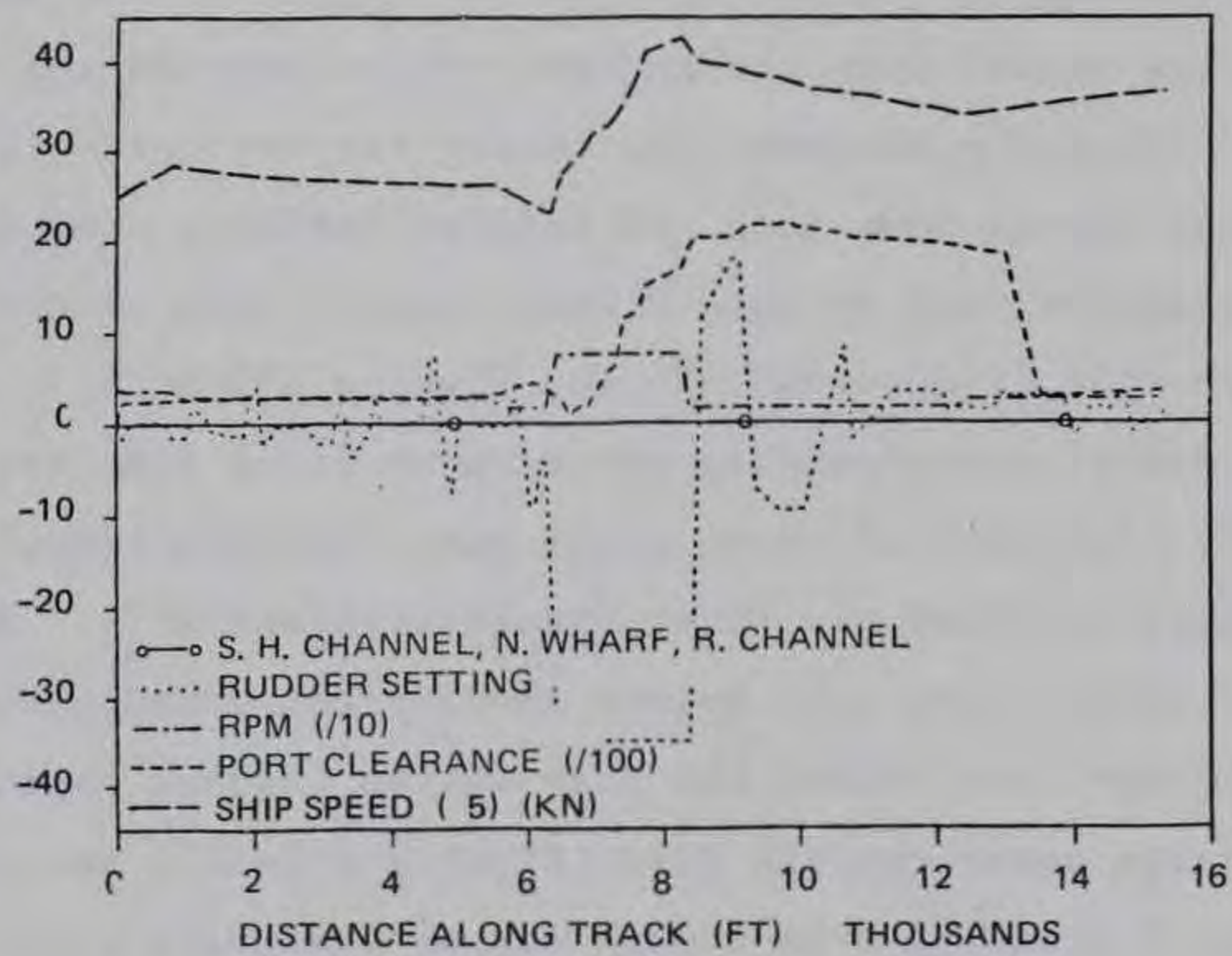
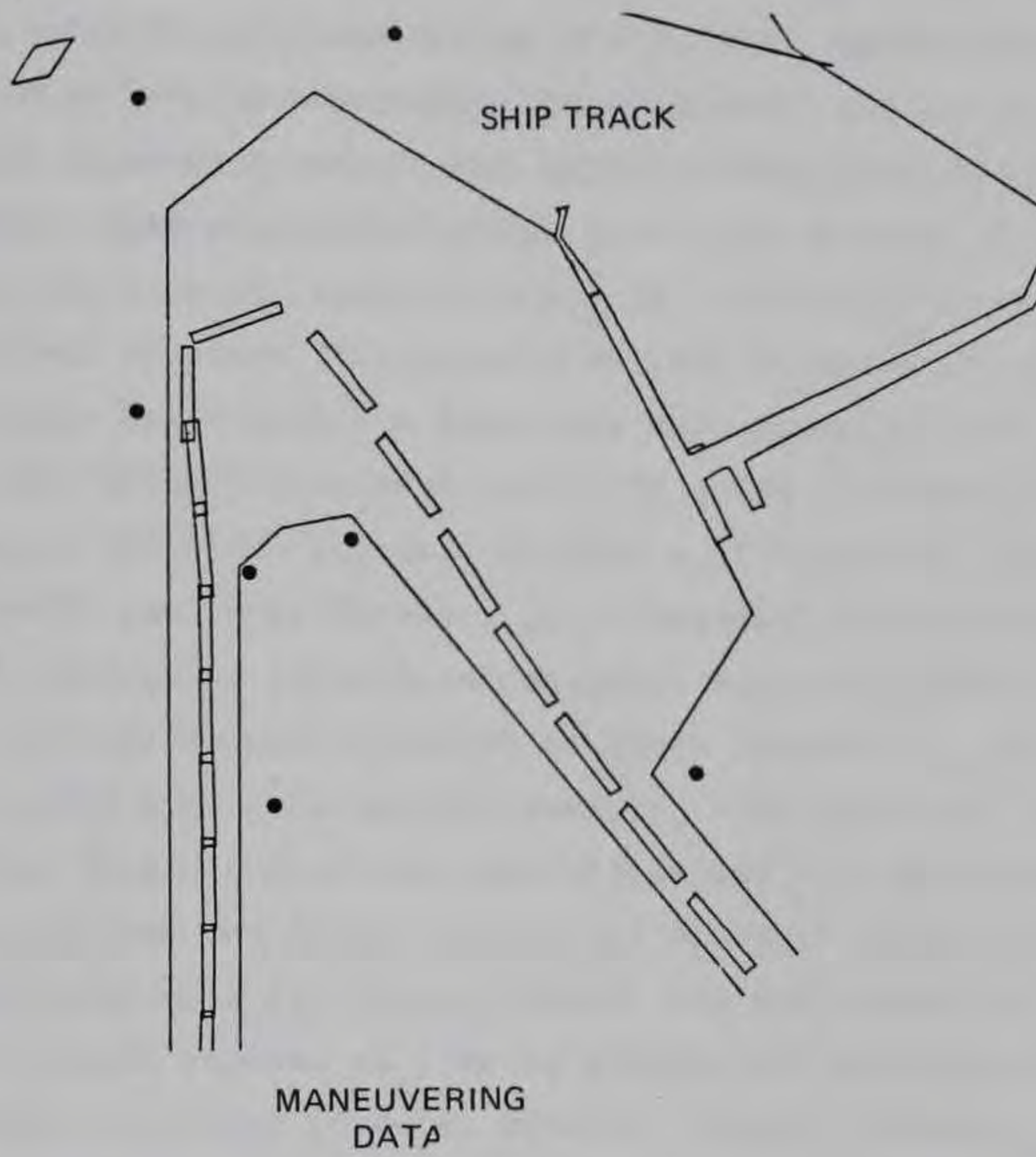

Figure 24. 638-ft containership test, ebb tide, Pilot B

(Figures A1-A40). Pilot A docked the larger tanker very high (farther north) on the first two tests (Figures A9 and A11) but was able to make a tighter turn in the next two tests (Figures A13 and A15). This is also true of Pilot A's base tests (Figures A1-A8). Pilot B's second base test (Figure A19) was the best base test due to the uniformity throughout the turn as well as obtaining the desired final docking posture. The other three base tests show only small variations on both sides of this test which indicates a high degree of consistency with succeeding tests. In the deep tests, Pilot B was fairly consistent with the exception of DTFT B4 (Figure A31) where he docked the tanker too far north. This happened when the pilot was distracted while performing this particular maneuver. Pilot C's first base test (Figure A33) shows the tanker approaching the wharf in a uniform pattern, while his second test (Figure A35) shows the implementation of a second very long kick-turn that resulted in the docking posture being achieved quite a distance from the wharf. From this position, the vessel could be docked at any of the four berthing areas. The next two deep tests (Figures A37 and A39) show Pilot C crabbing across the maneuvering area and positioning the vessel closer to the wharf but still leaving enough distance to dock at any of the berthing areas.

53. The strategies for the transits under ebb tide conditions vary significantly between the two tankers as well as between pilots. Pilot B's transits with the smaller tanker (Figures A41-A48) involve a right-then-left kick-turn, positioning the tanker near the south end of the wharf so the pilot could maneuver the vessel into the currents while approaching the desired berthing area. Pilot C positioned the vessel farther north, letting the current drift the vessel down into the desired berthing area (Figure A57). The latter strategy is used by both Pilots B and C when maneuvering the larger tanker under ebb tide (Figure A49-A56 and Figures A59-A60).

54. The 810-ft containership tests under flood tide are presented in Figures A61-A64. All four of these tests were very successful transits. The only inconsistency is Pilot B's first transit (Figure A63). The vessel was set into the required right turn before leaving the Southampton Channel resulting in a tighter turn around the nose of the turning basin. The 810-ft containership tests under the ebb tide (Figures A65-A67) were all considered to be unsuccessful transits even though one of the track plots indicated that the vessel could be kept within the maneuvering area and channel boundaries (Figure A67). However, vessel speed was too high to be considered a safe

operation, e.g., above 8 knots. The controllability of the vessel decreases when it is traveling in the direction of the current due to a decrease in relative speed of the water with respect to the rudder. Also the use of a kick-turn in this situation causes an unacceptable increase in speed.

55. The 638-ft containership transit (Figure A68) under the ebb tide conditions was discussed earlier and it was pointed out that it was a very easy maneuver to complete with success.

PART V: CONCLUSIONS AND RECOMMENDATIONS

Conclusions

56. Results of the simulations show that a 150,000-dwt tanker loaded to 10-ft greater draft than is now possible can be maneuvered with acceptable margins of safety in the proposed channel; experienced pilots familiar with the project should provide additional safety factors, as would the availability of tug assist.

57. Acceptable tanker docking postures can be achieved on flood tide for the existing and deepened channels using the 87-kdwt and the 150-kdwt tankers, respectively. The larger tanker tended to drift farther north in the maneuvering area.

58. Maneuvering inbound with ebb tide is somewhat easier than with flood tide. The larger tanker, however, requires special care to keep the ship bow well into the ebbing current. Successful docking postures can also be obtained for ebb tide.

59. All tests indicate that it is critically important to reduce forward speed in Southampton Channel to 5 knots or less before starting the large right kick-turn into the maneuvering area.

60. The 810-ft containership tests on flood tide indicate that maneuvering around the point and lining up with the Richmond Harbor entrance channel can be done but required considerable rudder activity.

61. None of the transits of the 810-ft containership under ebb tide conditions were considered to be safe maneuvers since, even with the best transit, the control of the vessel was in question at several points. Because of the astern currents, it was difficult to keep the speed of the ship within safe limits and the use of a kick-turn made control of the speed even more difficult. The simulation results indicate that the containership must be well into the maneuvering area before the start of the turn in order to have enough space for lining up with the entrance channel.

62. Cutting off the nose at the turning point as proposed by the San Francisco District does not seem to be beneficial except perhaps to the large tankers during ebb tide conditions.

63. The combination of crosscurrents and wind and the necessity of reducing ship speed in Southampton Channel result in a crab angle that increases

ship maneuvering lane width above the normal design allowance.

64. A training period of about six simulations was required for pilots having no ship handling experience in order to produce consistently successful inbound docking posture maneuvers with the loaded tankers. A similar training period was required for the containership runs. A shorter training period was required for the experienced pilot.

65. A comparison of simulation results indicates that the proposed dredging project will not degrade the safety margin of tanker navigation into Long Wharf, especially if the present practice of using two 2,000-hp tugs is continued.

66. The 638-ft containership tests indicate that the proposed deepening project will not have a significant detrimental impact on the safety of present-day containerships maneuvering around the point and into the Richmond Harbor entrance channel.

Recommendations

67. A smaller cut of the turning point nose is recommended as being adequate, based on the simulation results. Two small dredging cuts at the north and south ends of the maneuvering area are recommended to improve the safety margin (Figure 25).

68. Some channel marker relocations are recommended as a result of the simulation tests. The recommended relocations are shown in Figure 25.

69. A reduction in width of the Southampton Channel from the present 600 ft is not recommended.

70. It is recommended that additional containership simulations of the large right turn and maneuvering into the Richmond Harbor entrance channel be conducted before Richmond Harbor deepening to allow the newer, larger containerships access.

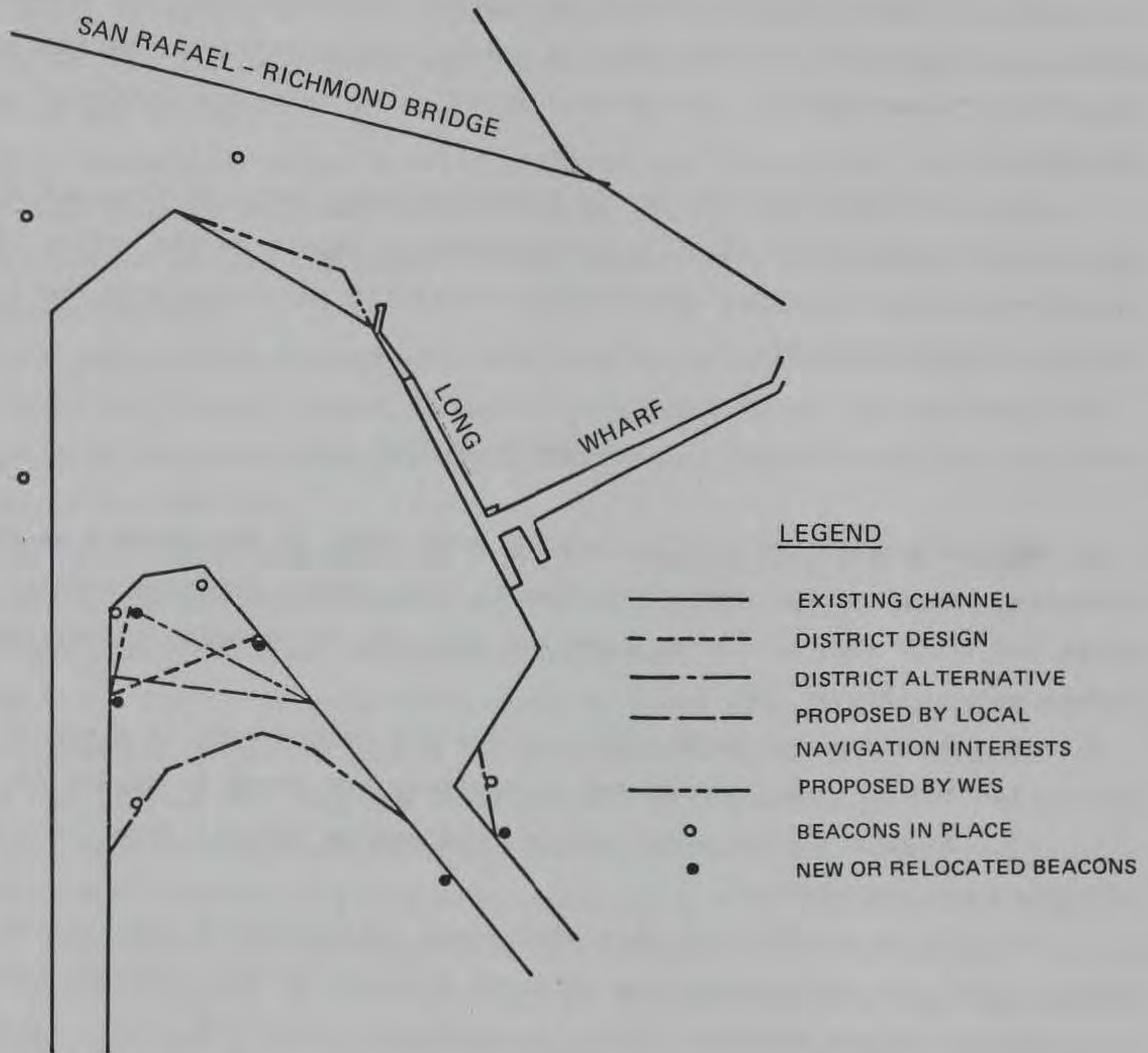

Figure 25. Alternative designs, maneuvering area

APPENDIX A
SHIP SIMULATION TEST RESULTS FOR ALL TRIALS



SHIP MANEUVERING
87PB BTFT A1

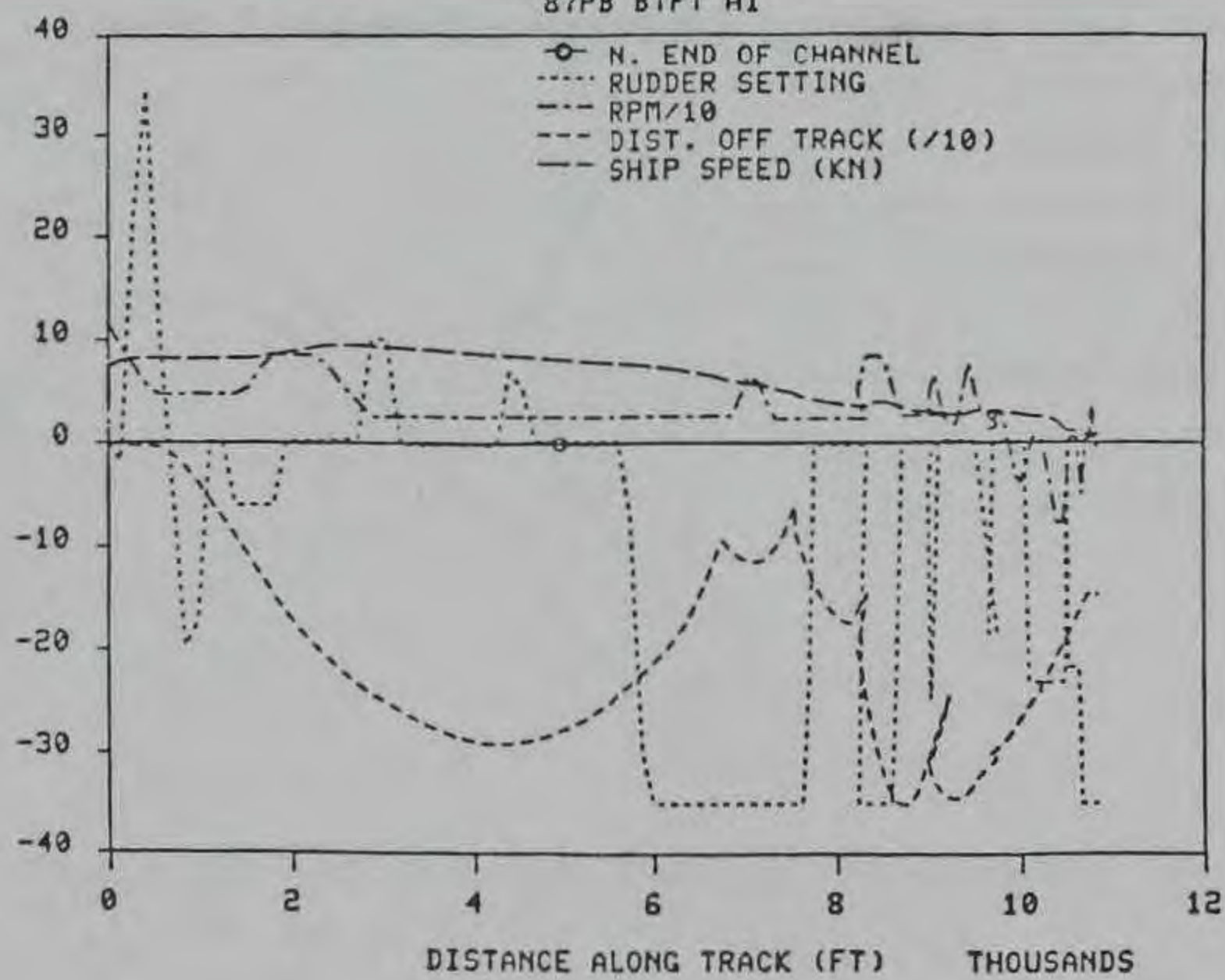

Figure A1. Ship maneuvering, 87PB BTFT A1

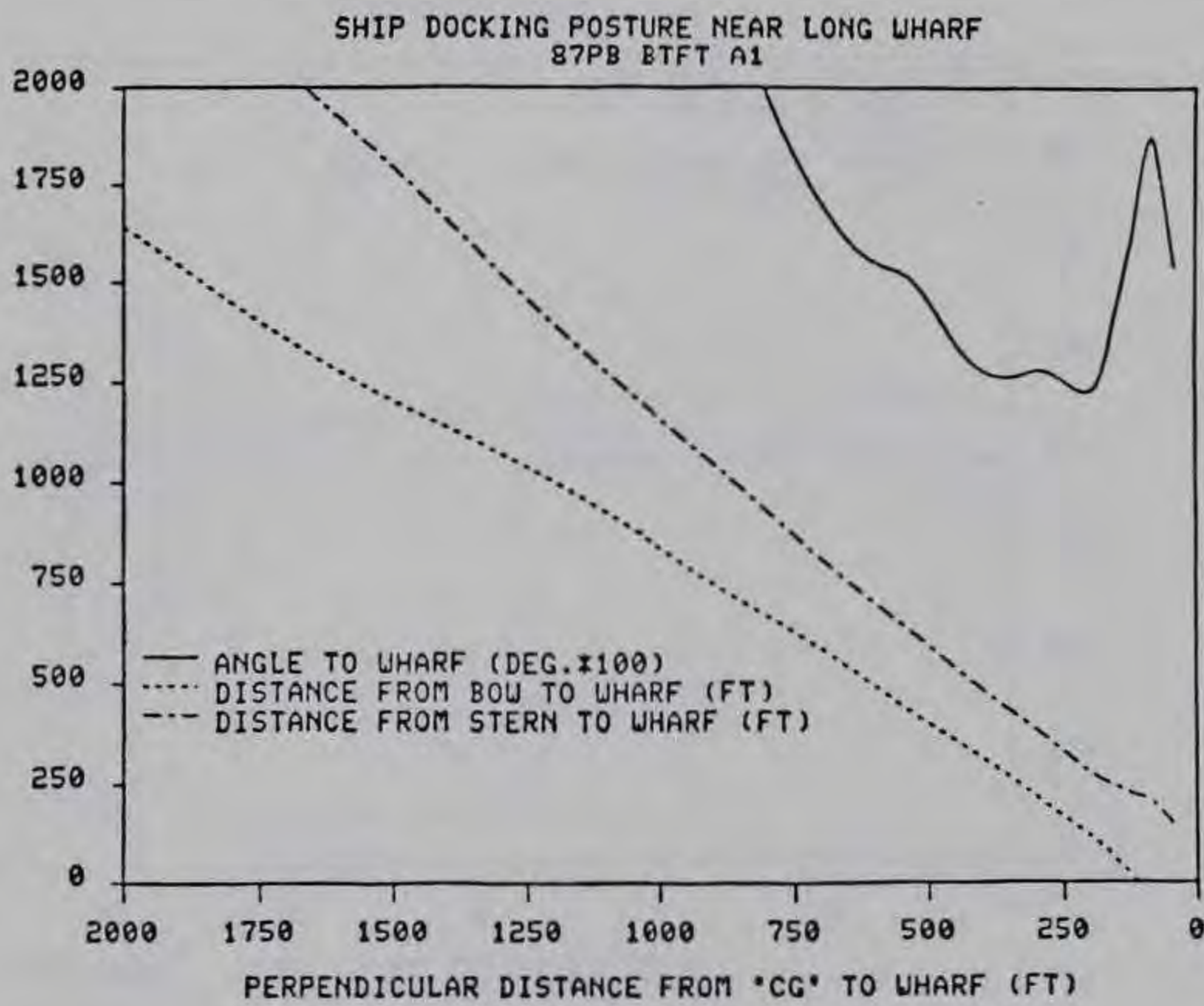
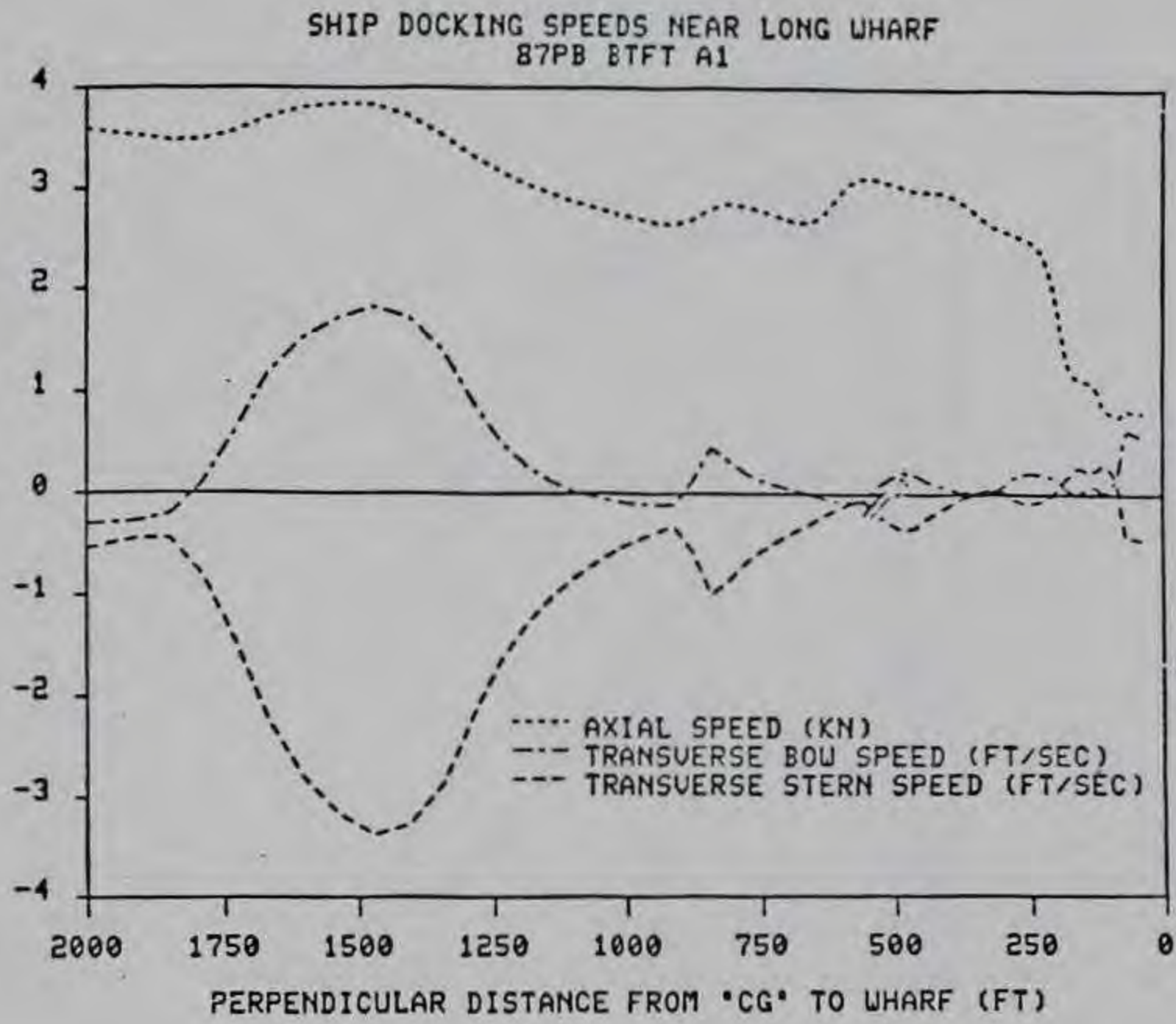
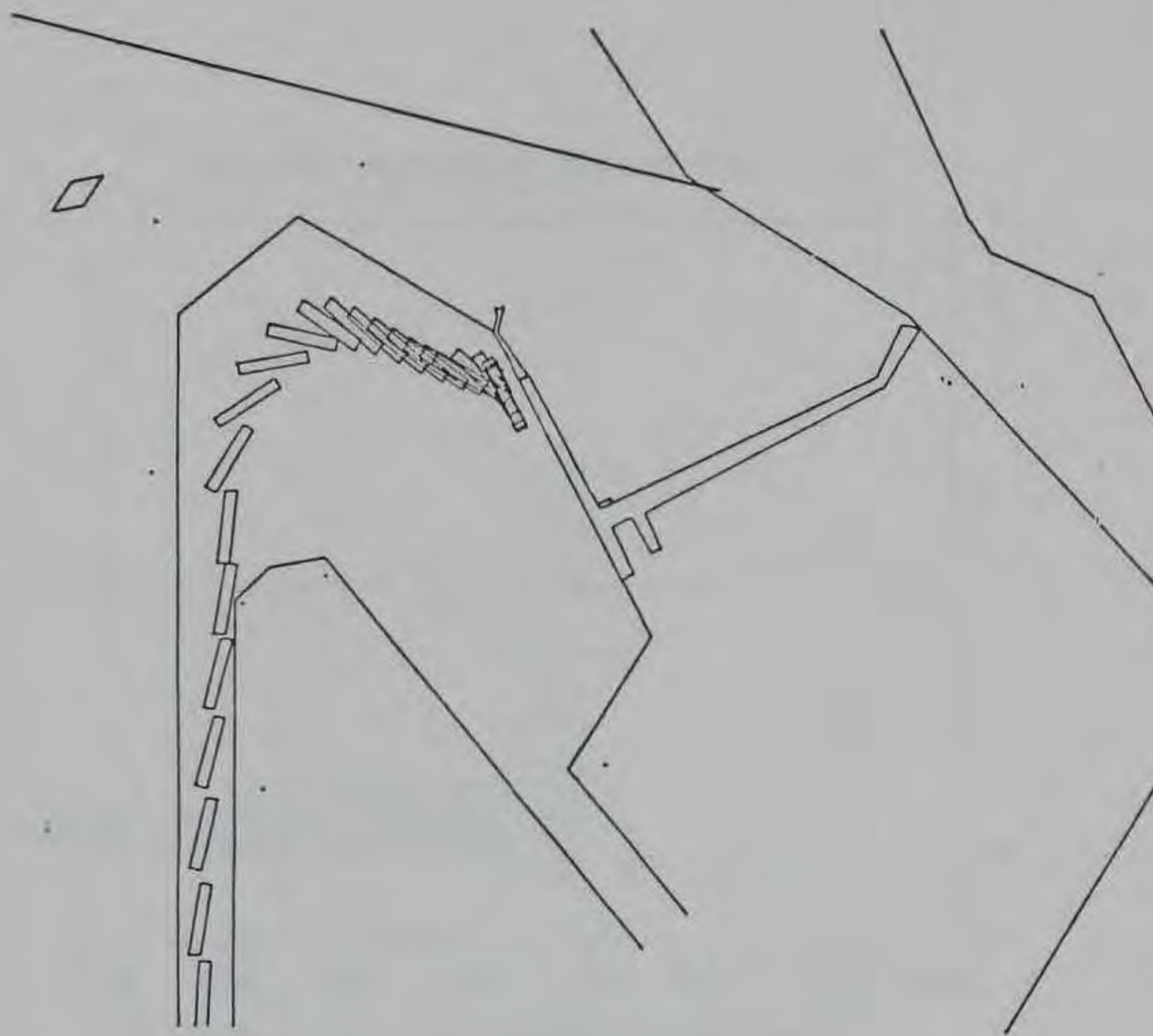

Figure A2. Ship docking speed and posture, 87PB BTFT A1



SHIP MANEUVERING
87PB BTFT A2

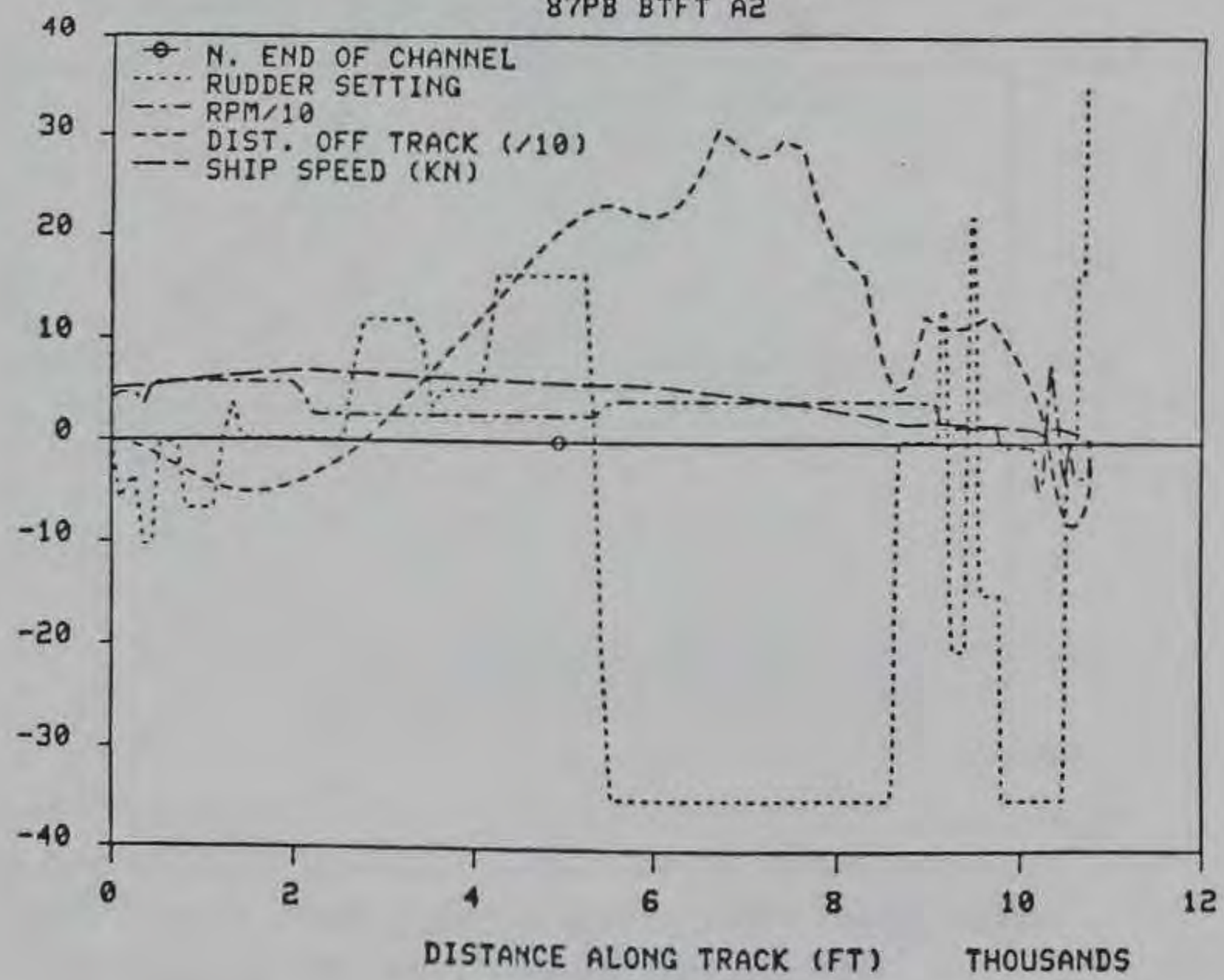

Figure A3. Ship maneuvering, 87PB BTFT A2

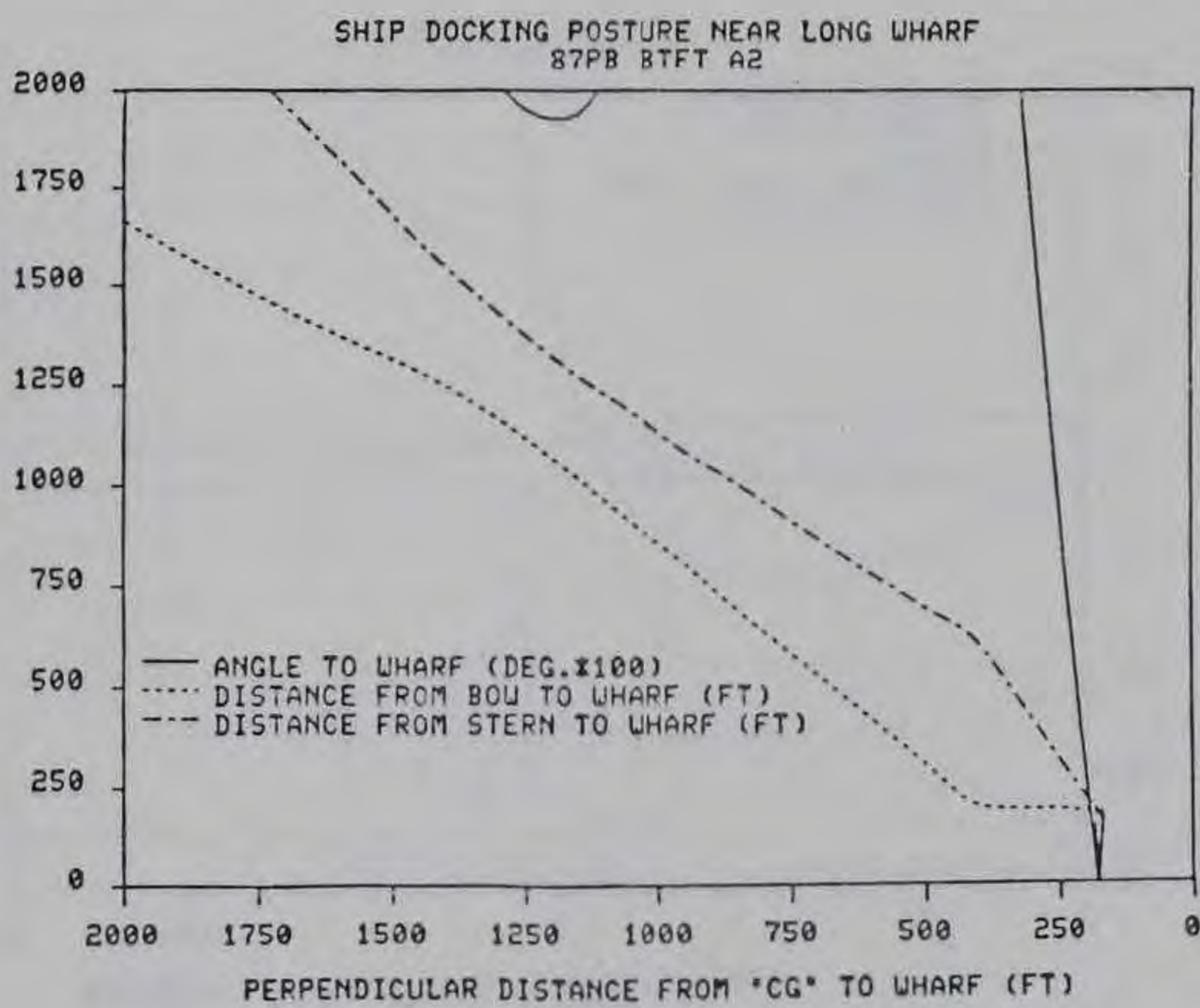
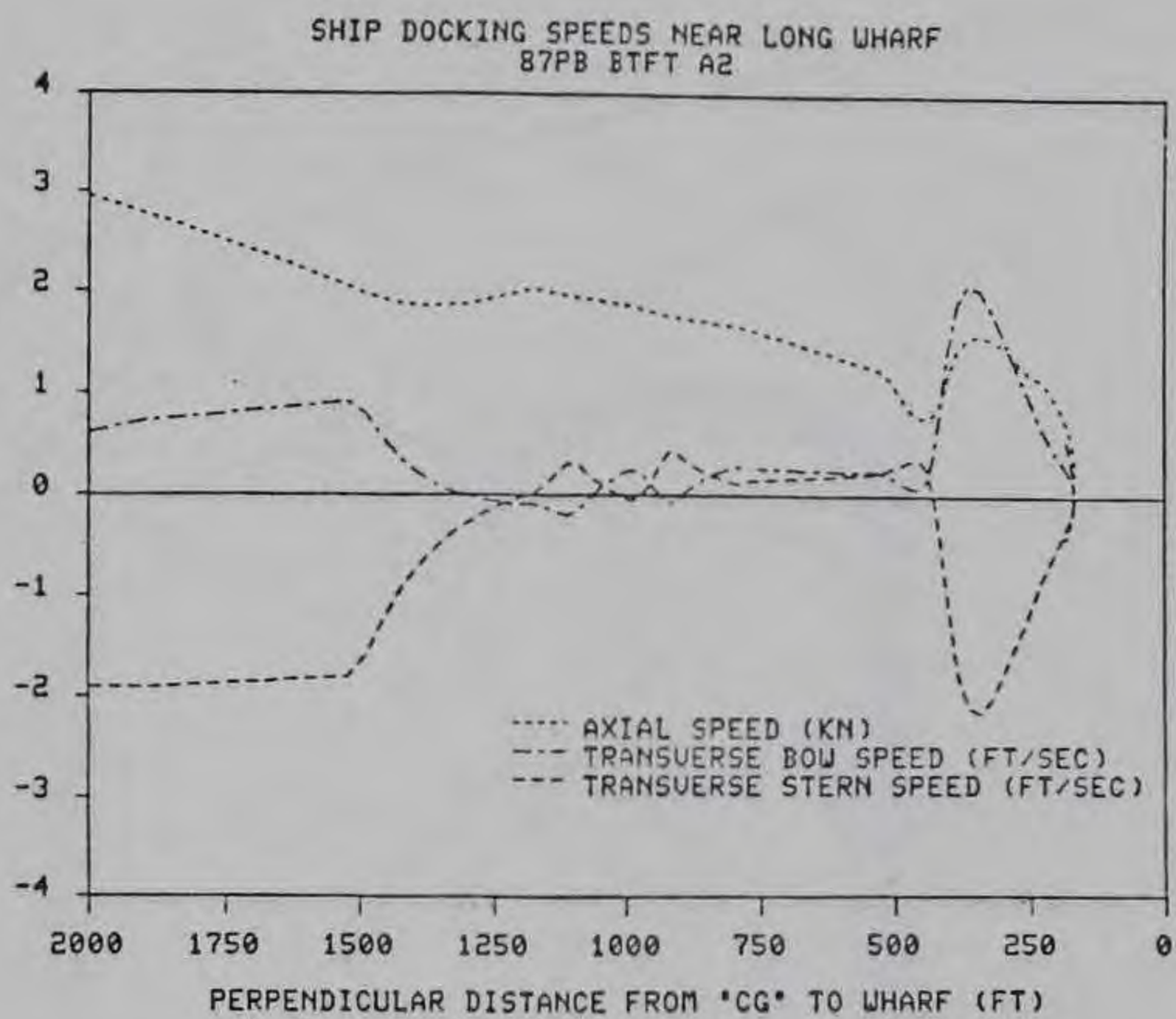

Figure A4. Ship docking speed and posture, 87PB BTFT A2

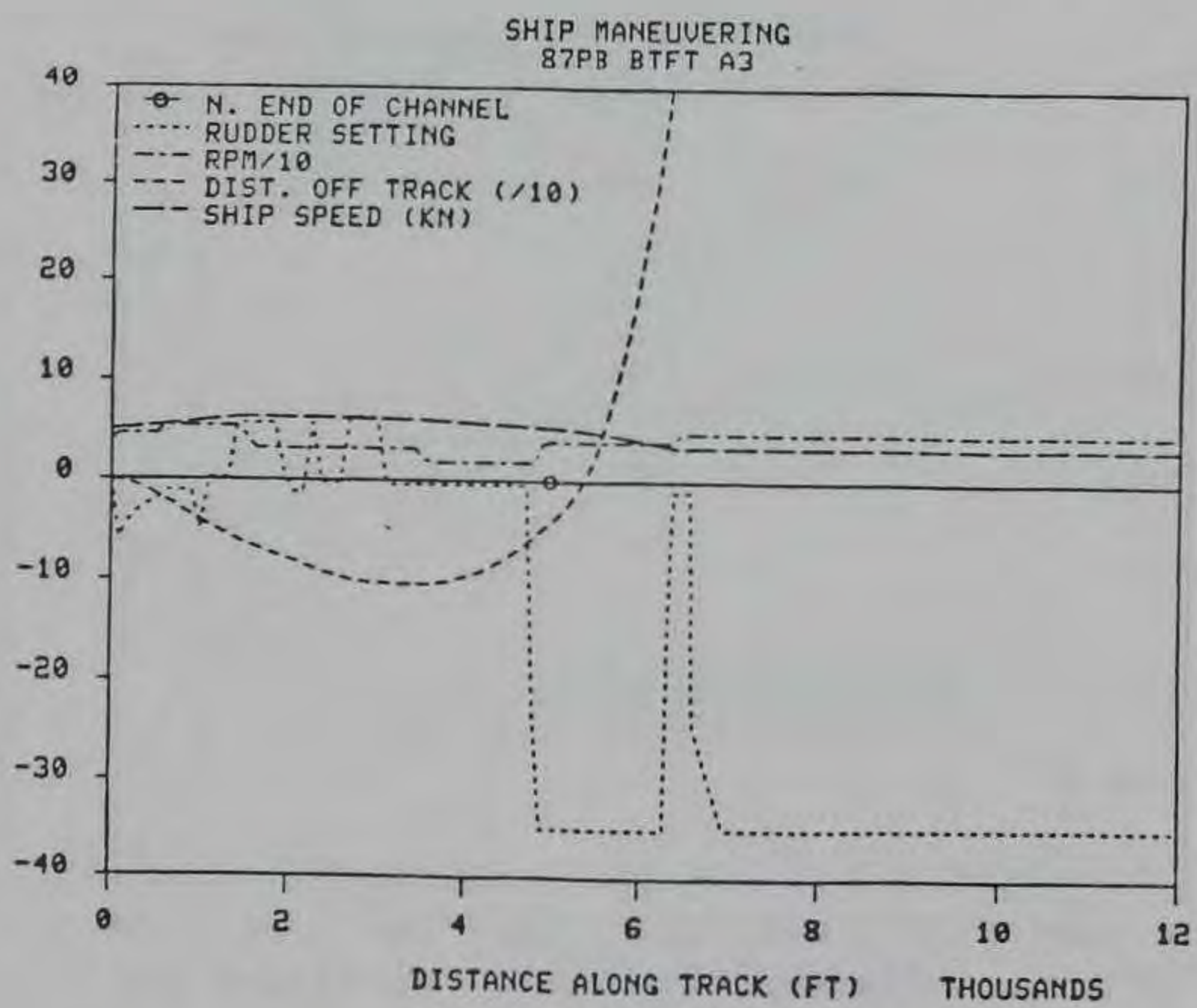
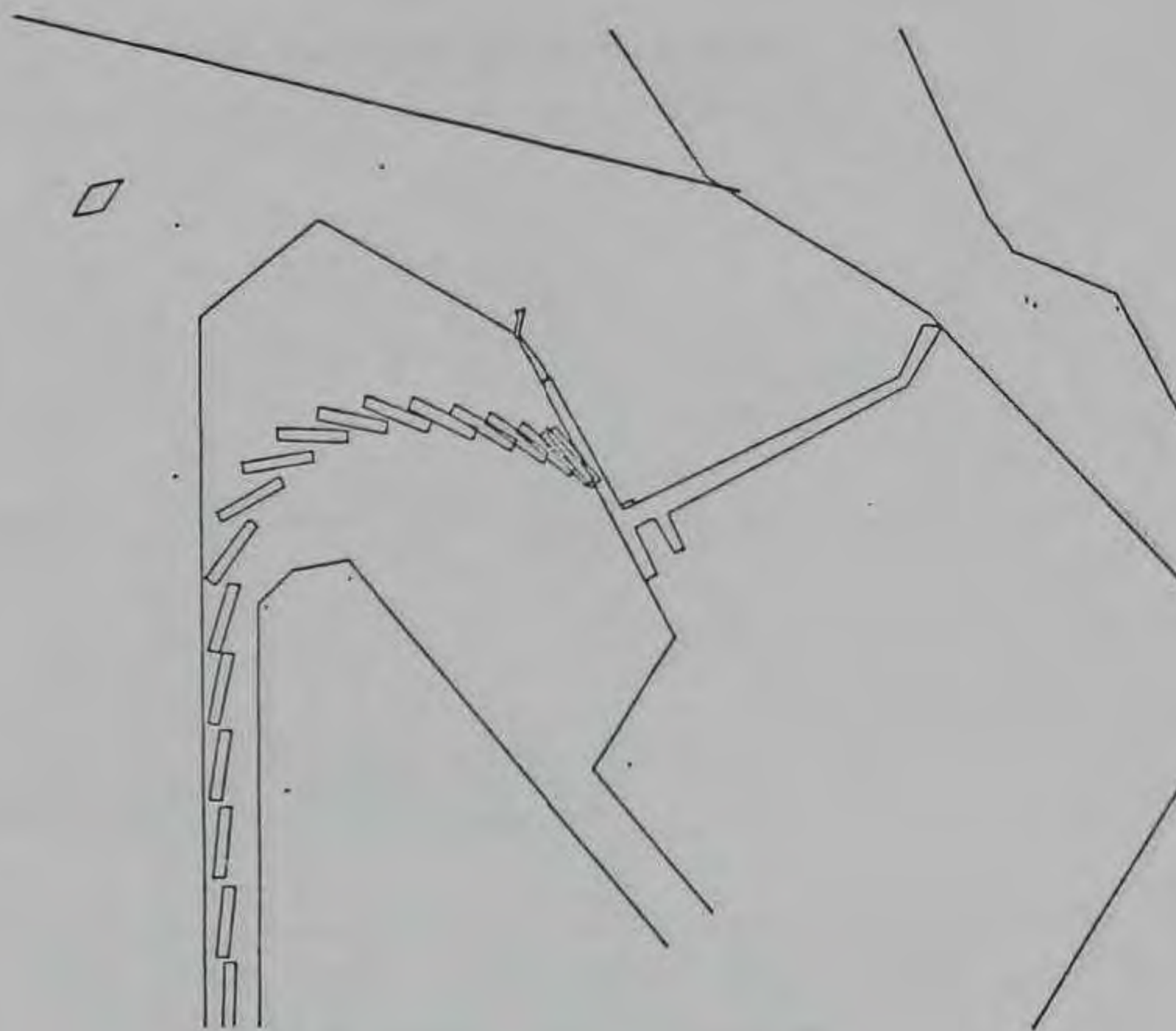

Figure A5. Ship maneuvering, 87PB BTFT A3

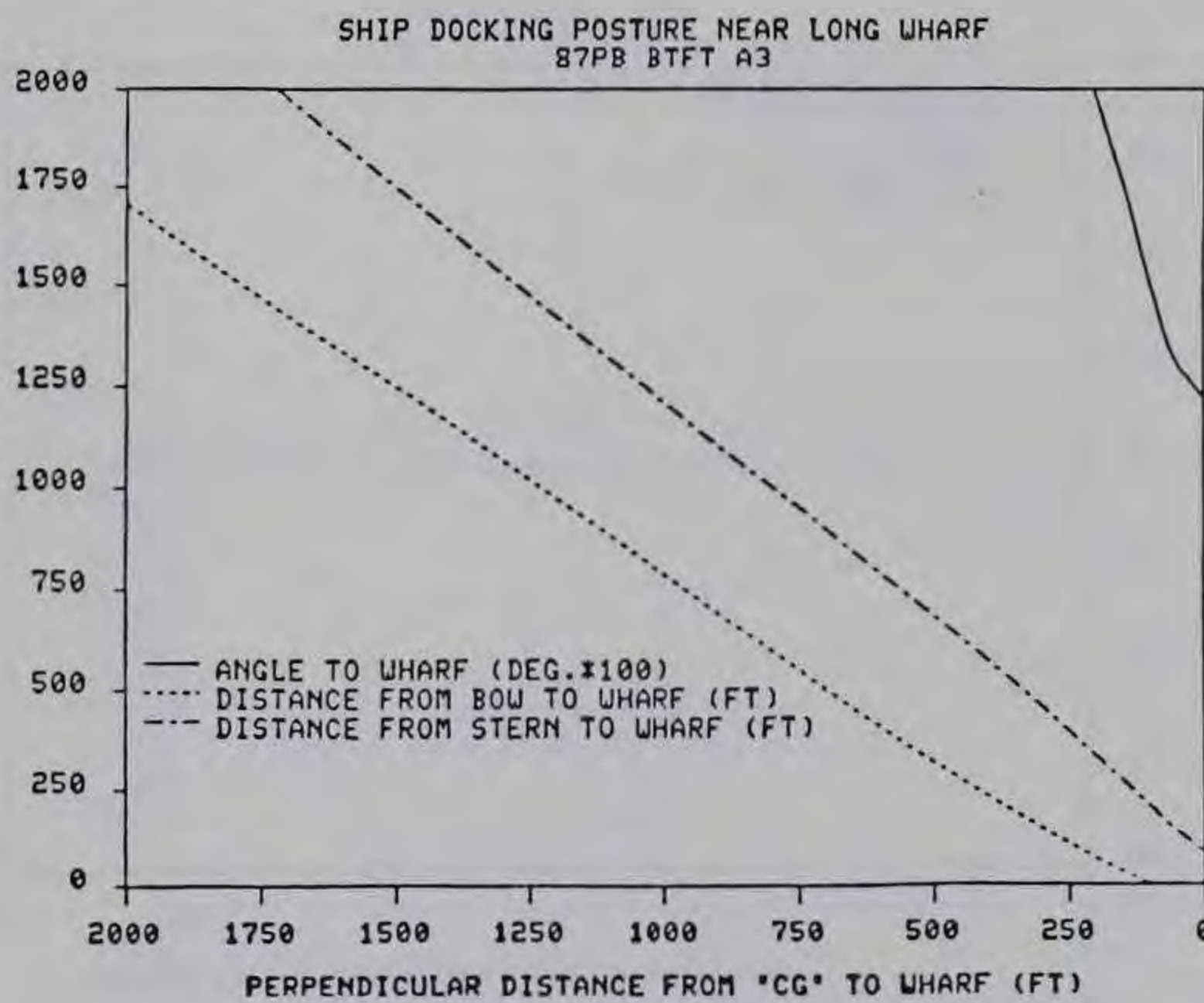
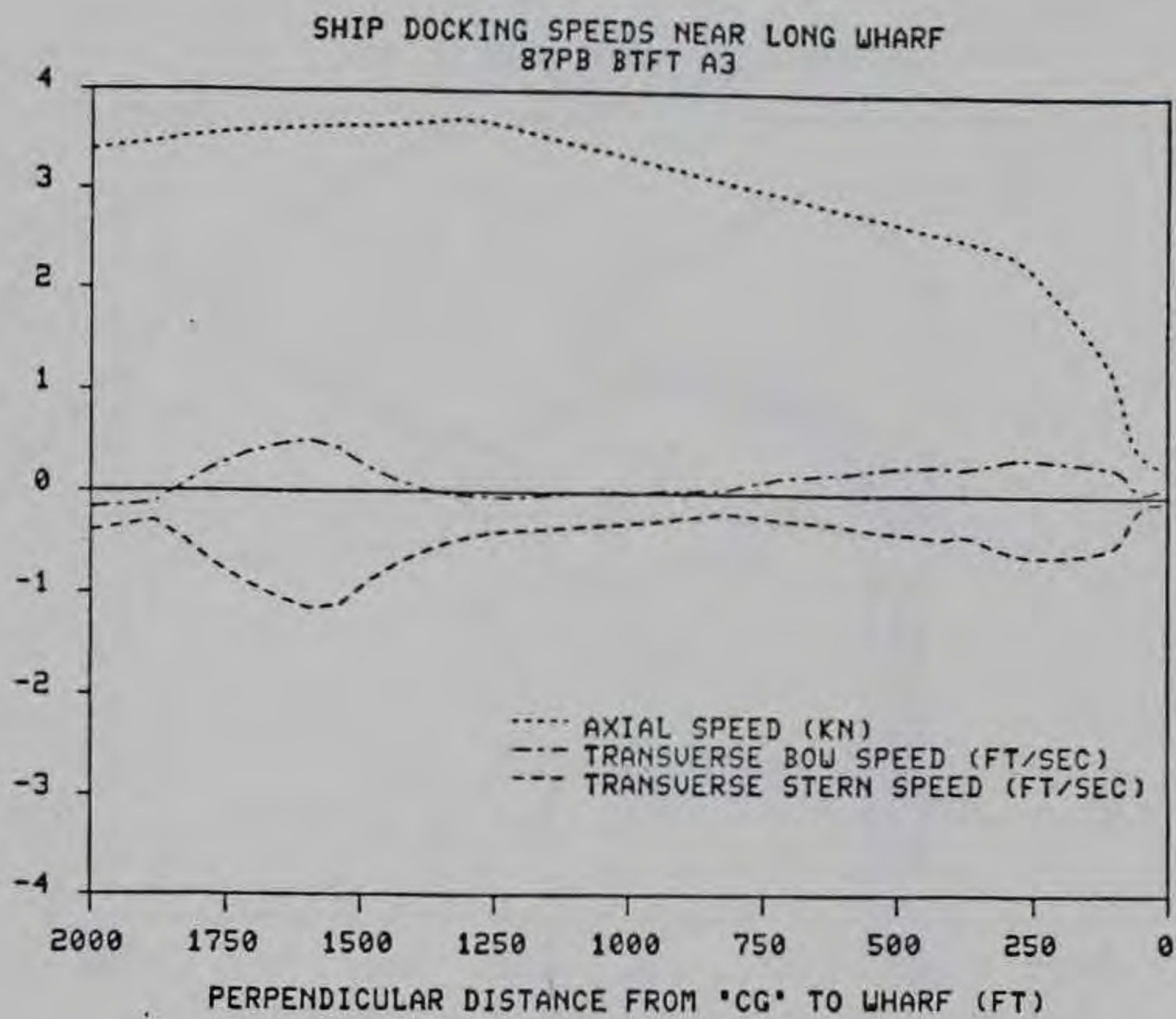

Figure A6. Ship docking speed and posture, 87PB BTFT A3

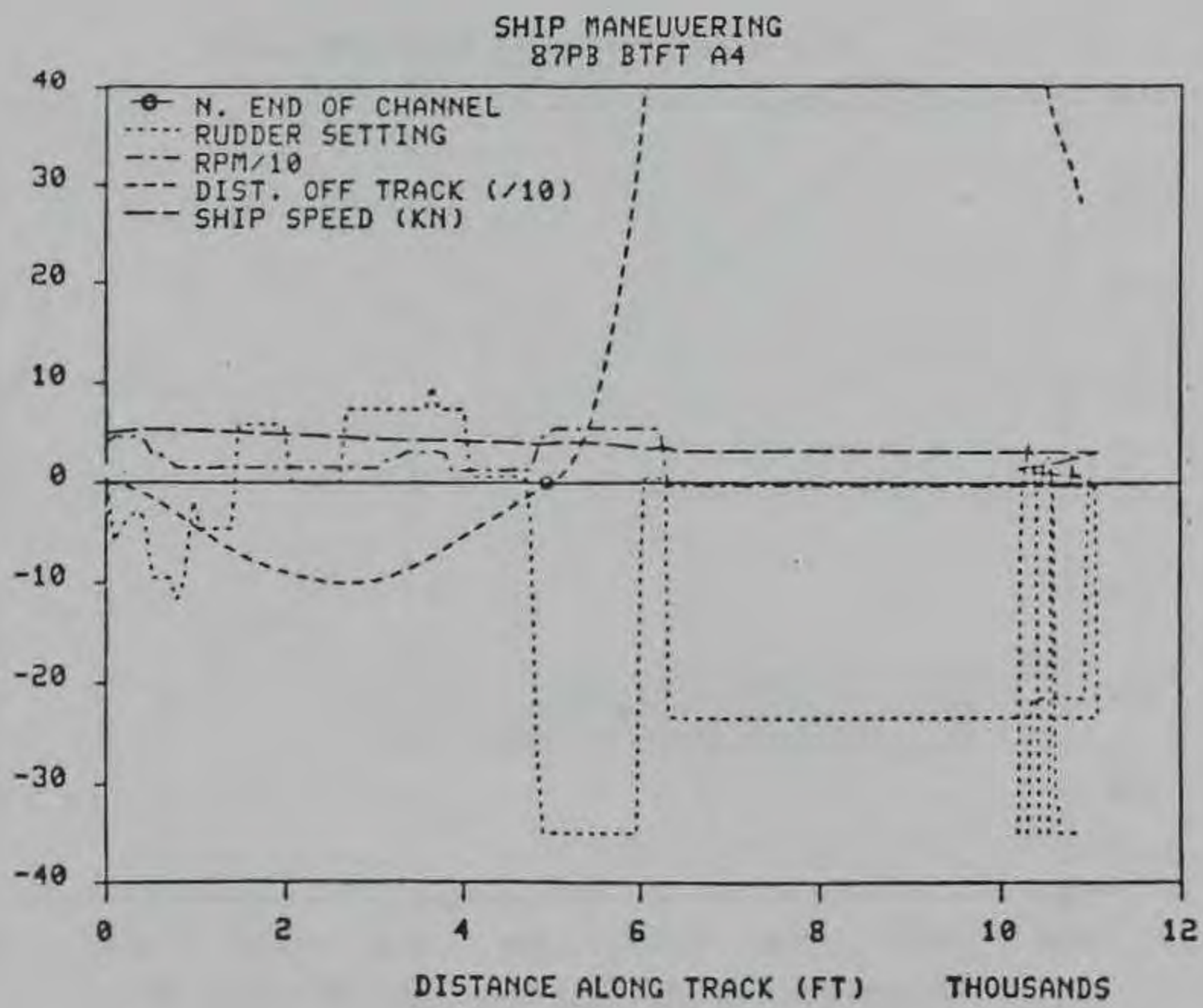
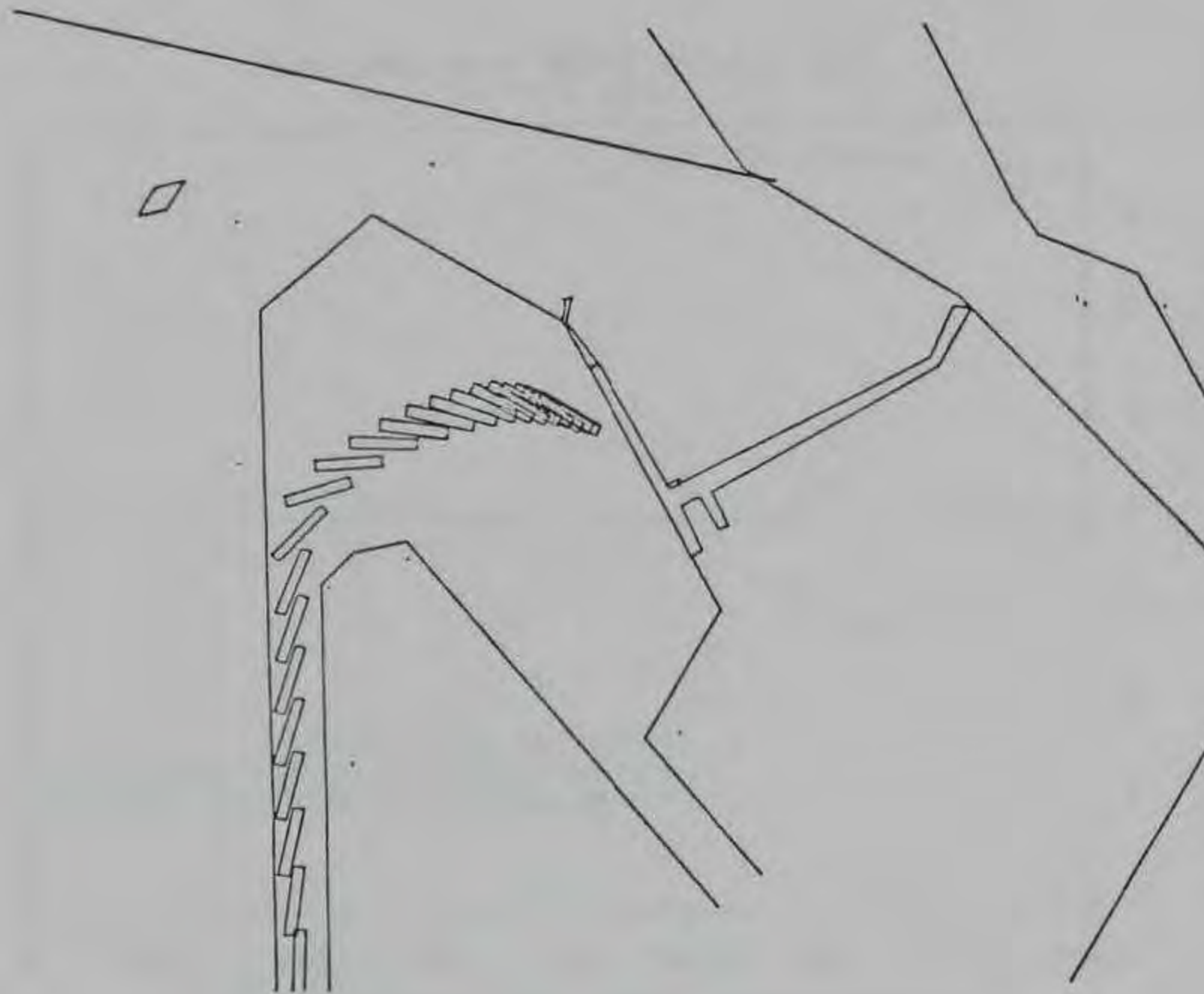

Figure A7. Ship maneuvering, 87PB BTFT A4

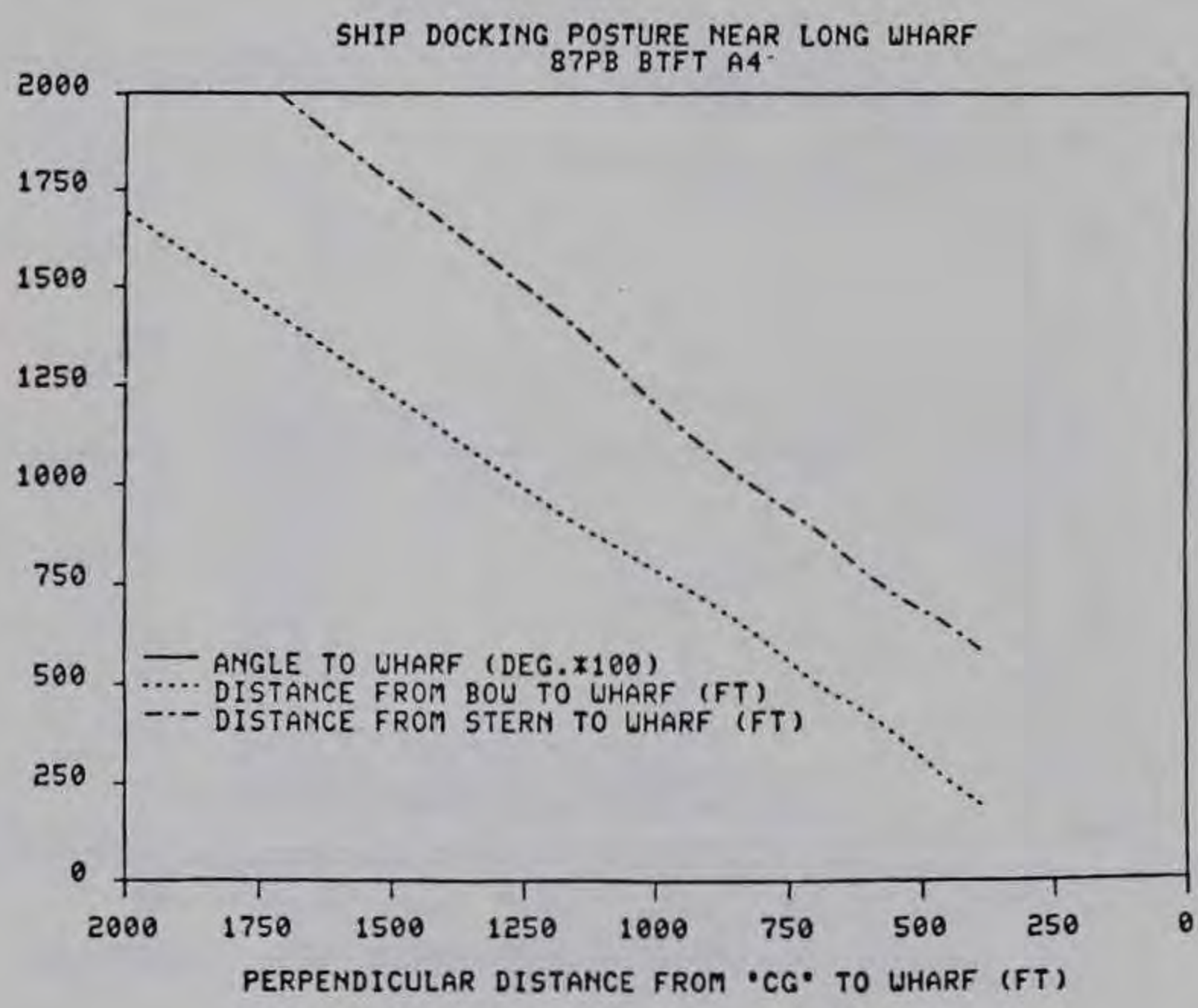
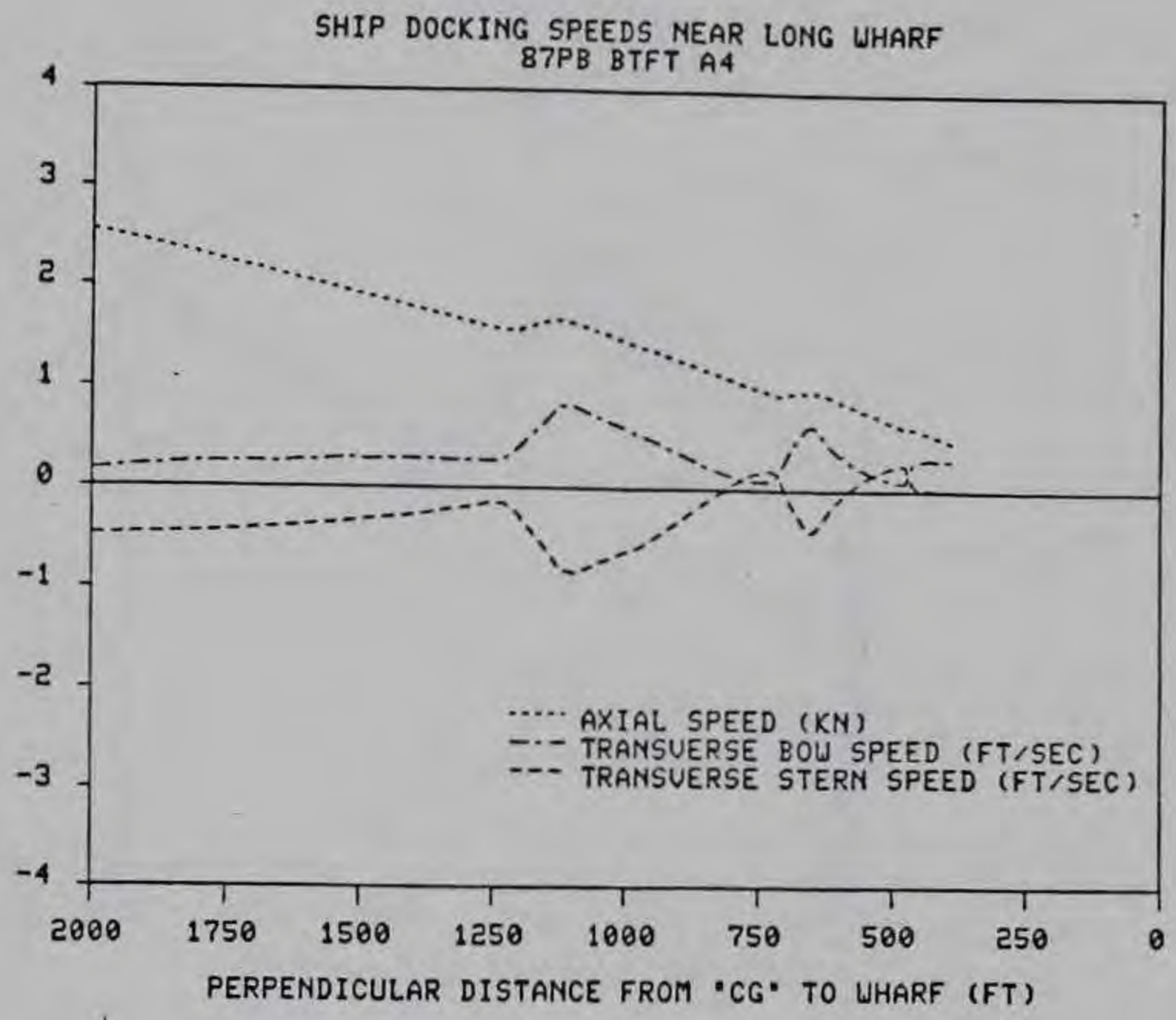

Figure A8. Ship docking speed and posture, 87PB BTFT A4

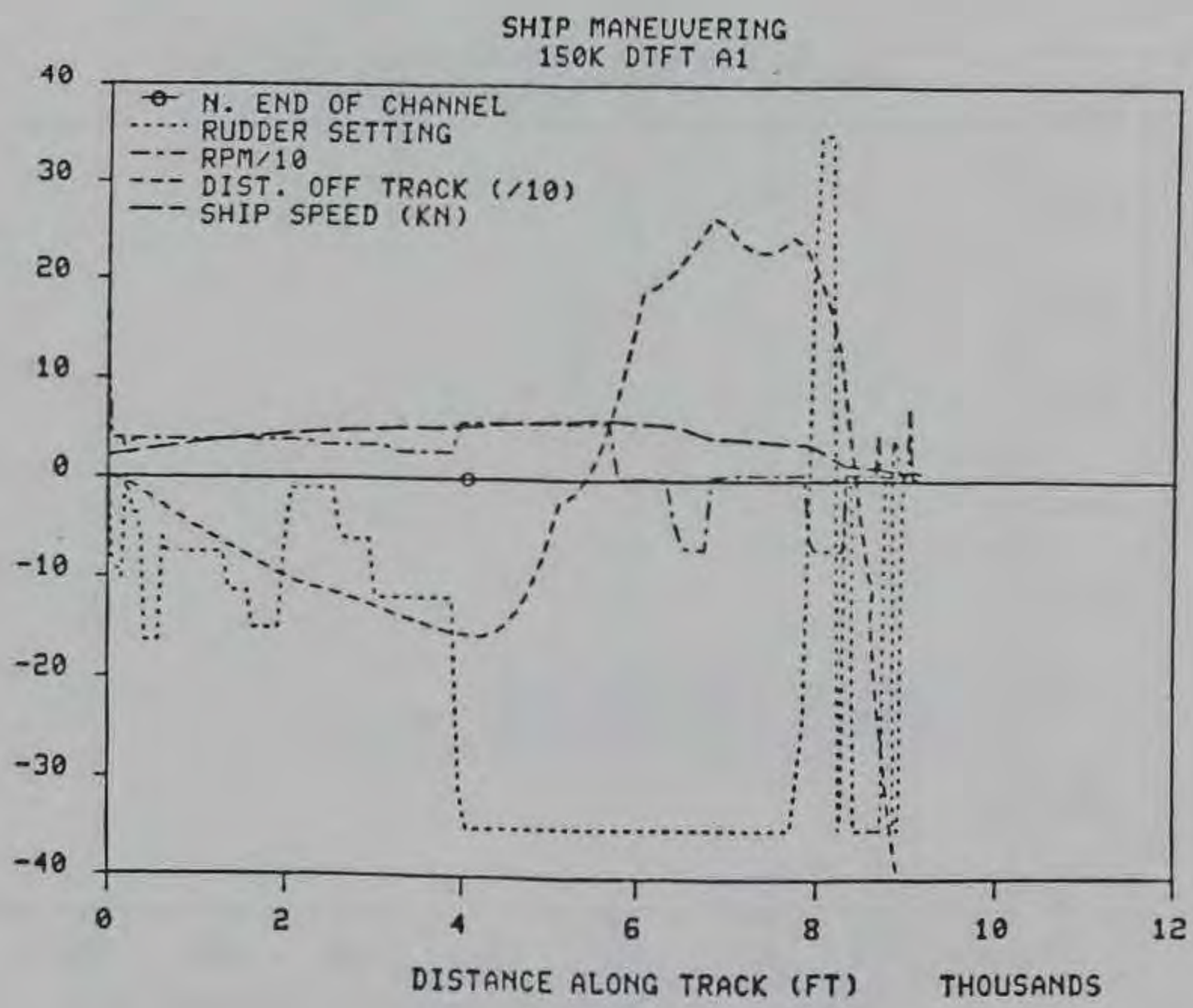
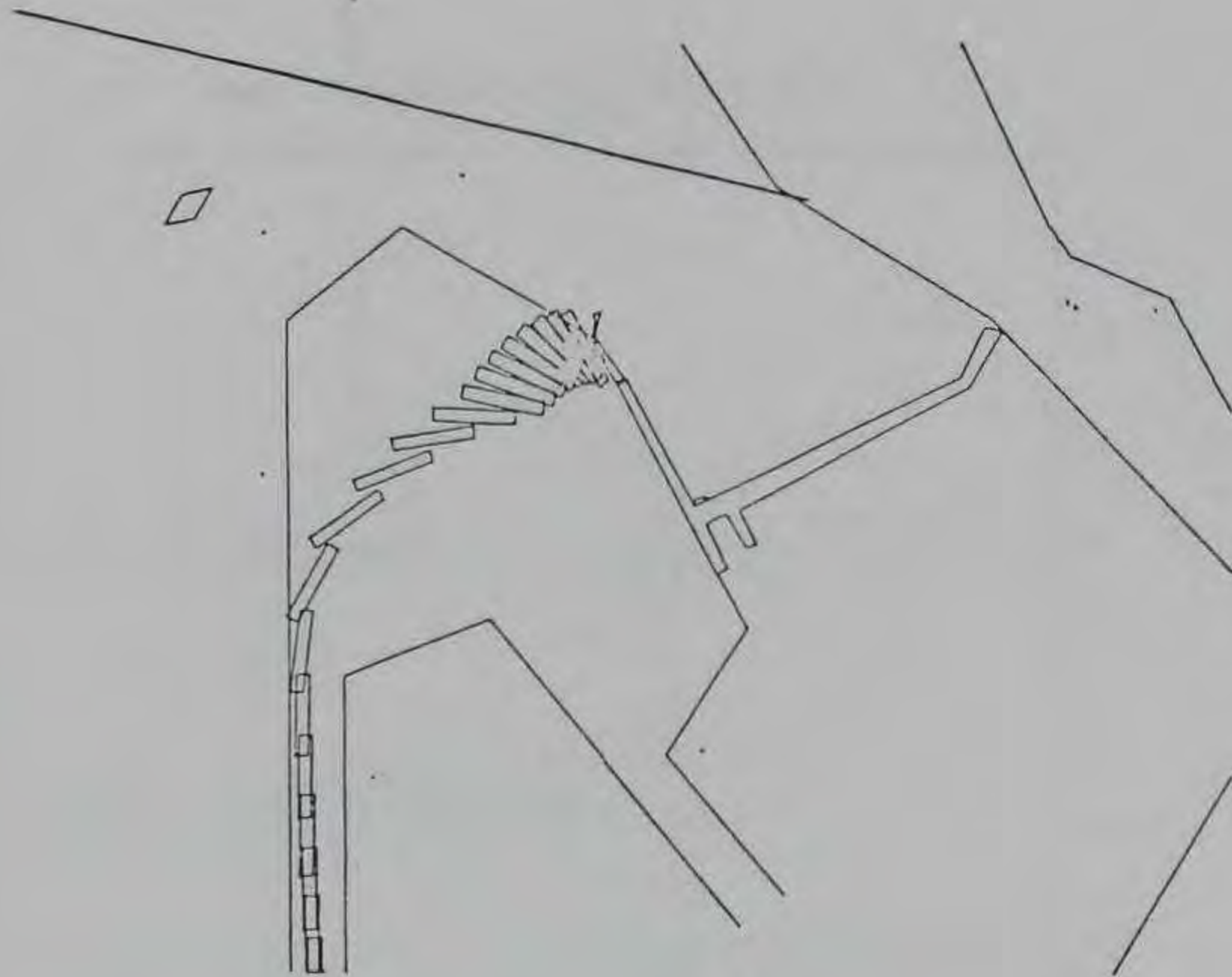

Figure A9. Ship maneuvering, 150K DTFT A1

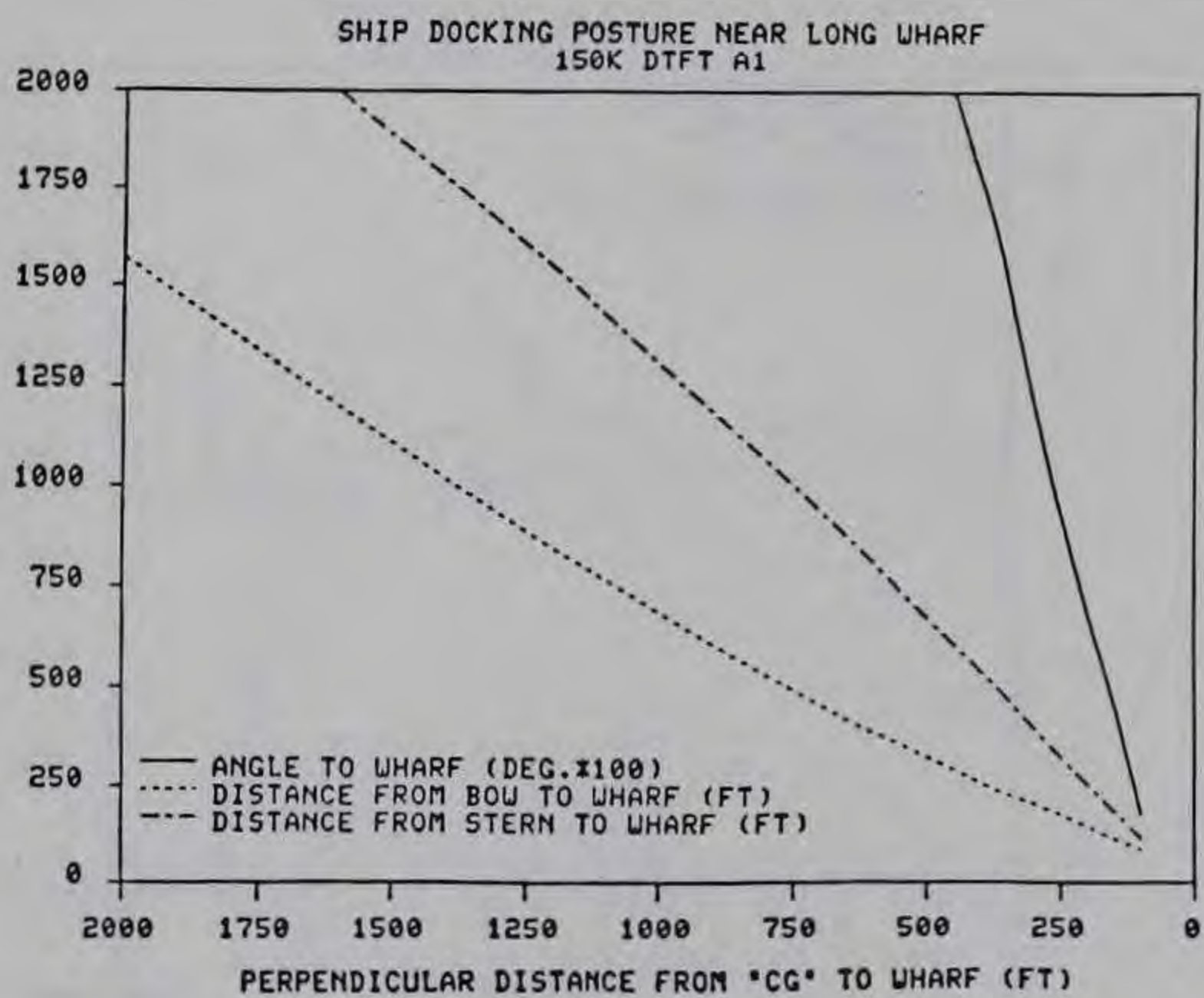
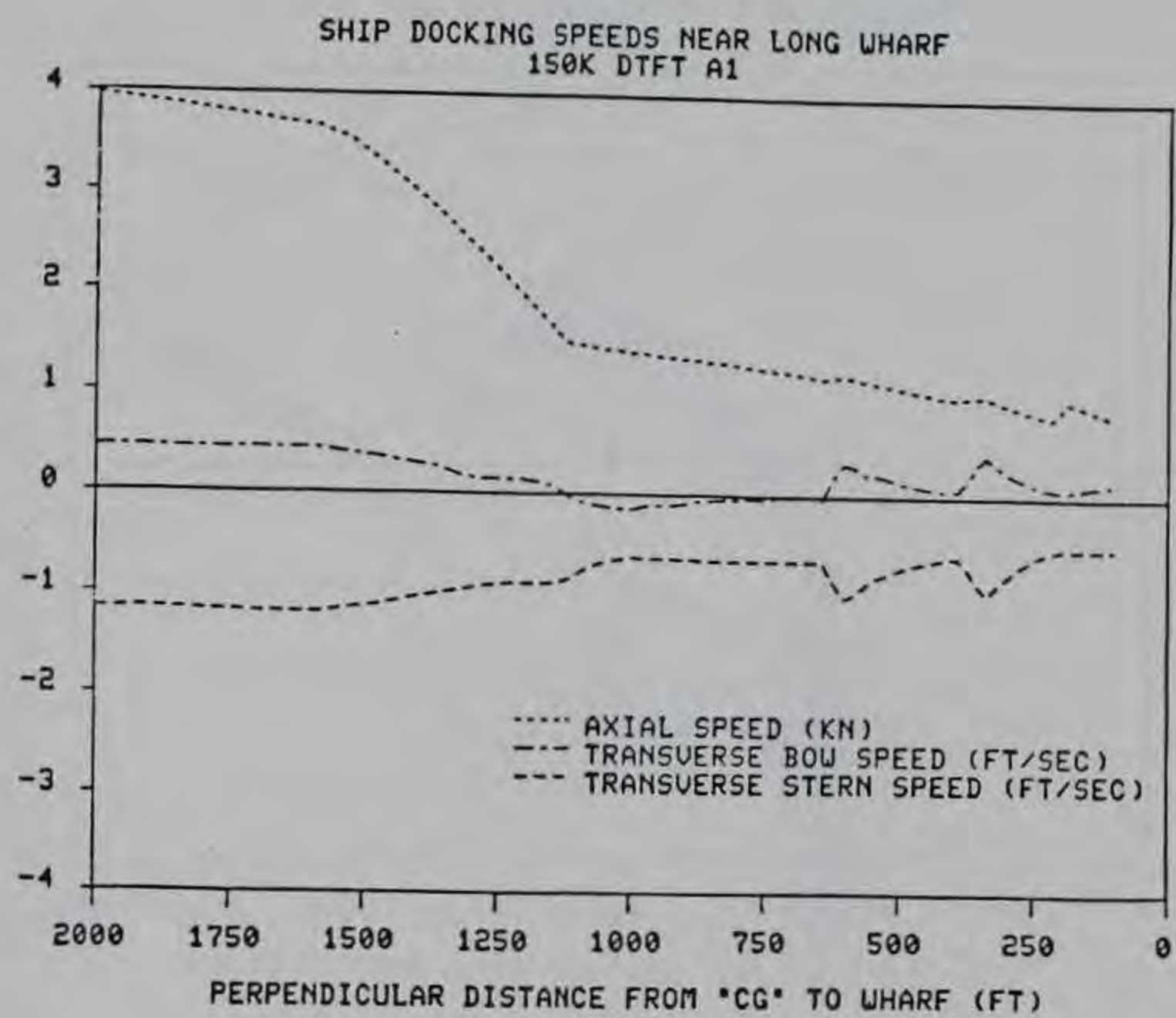

Figure A10. Ship docking speed and posture, 150K DTFT A1

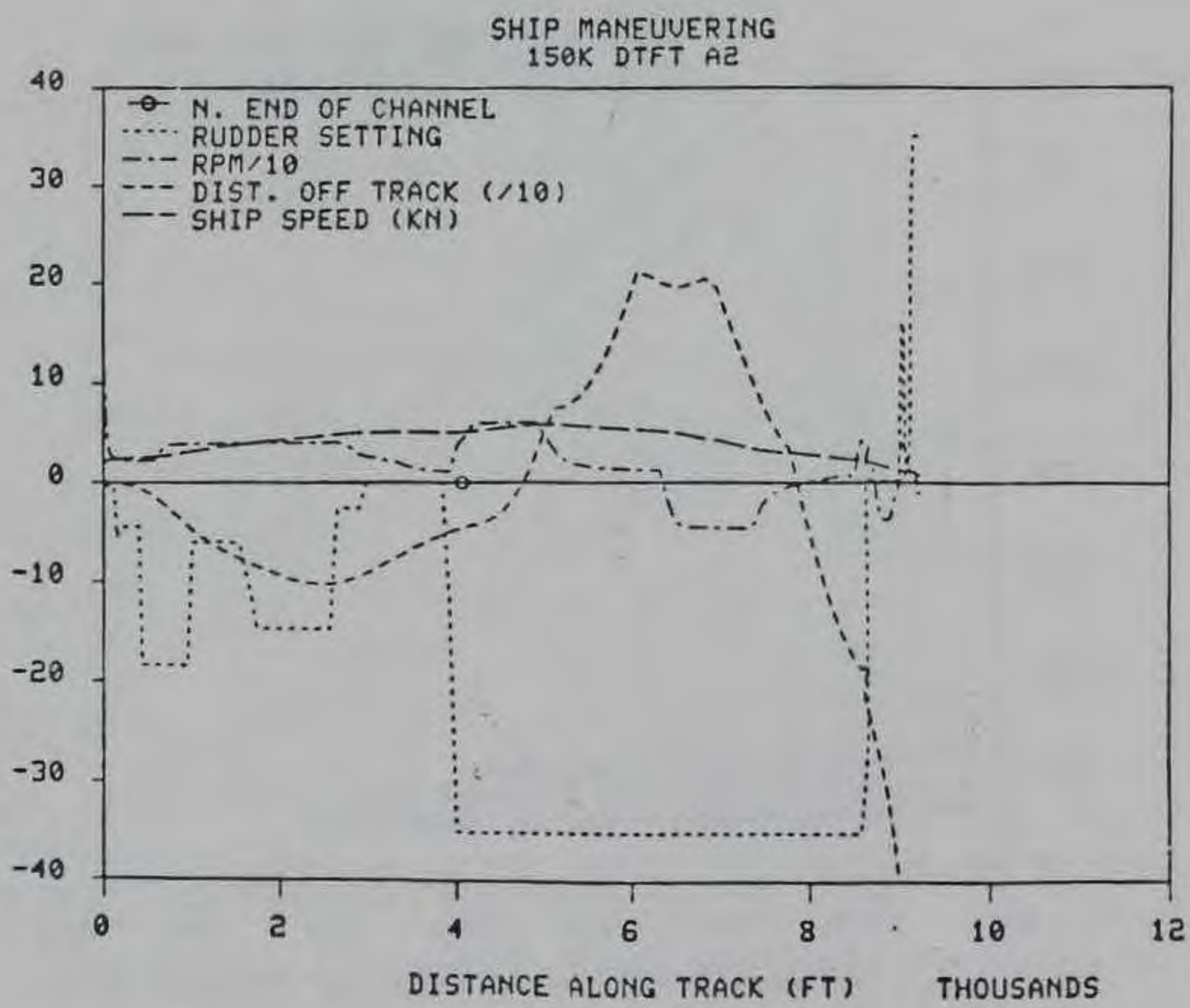
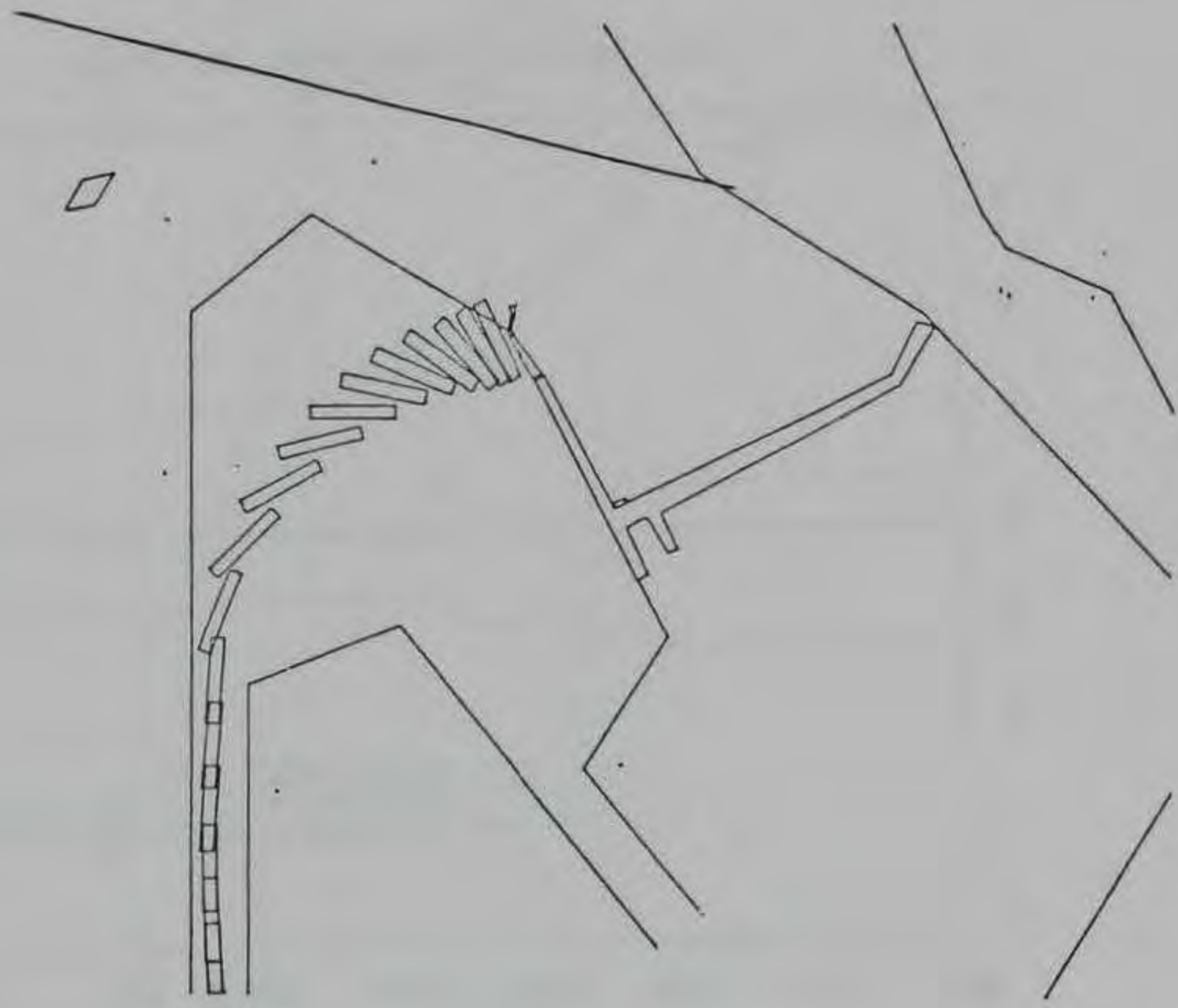

Figure A11. Ship maneuvering, 150K DTFT A2

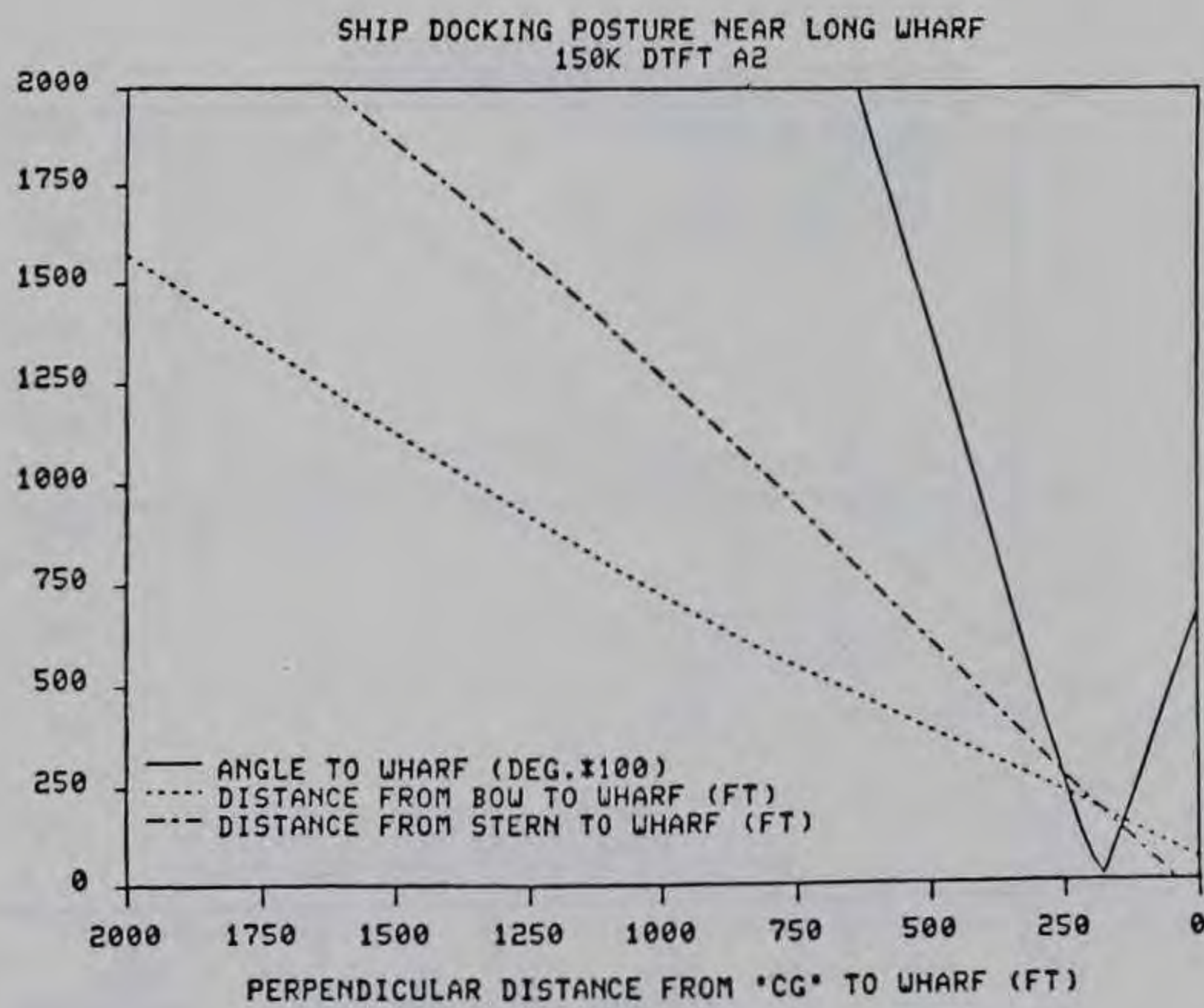
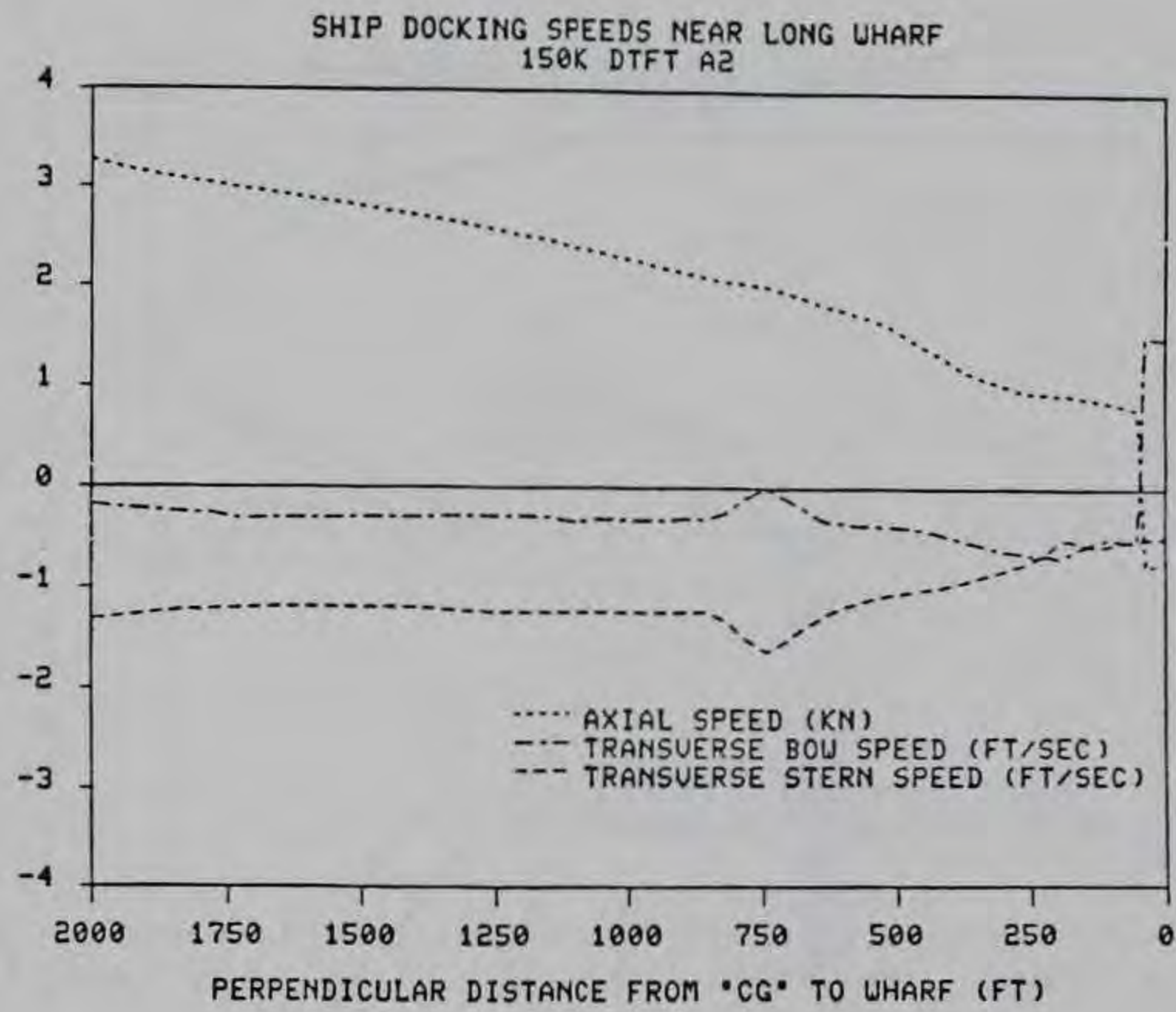

Figure A12. Ship docking speed and posture, 150K DTFT A2

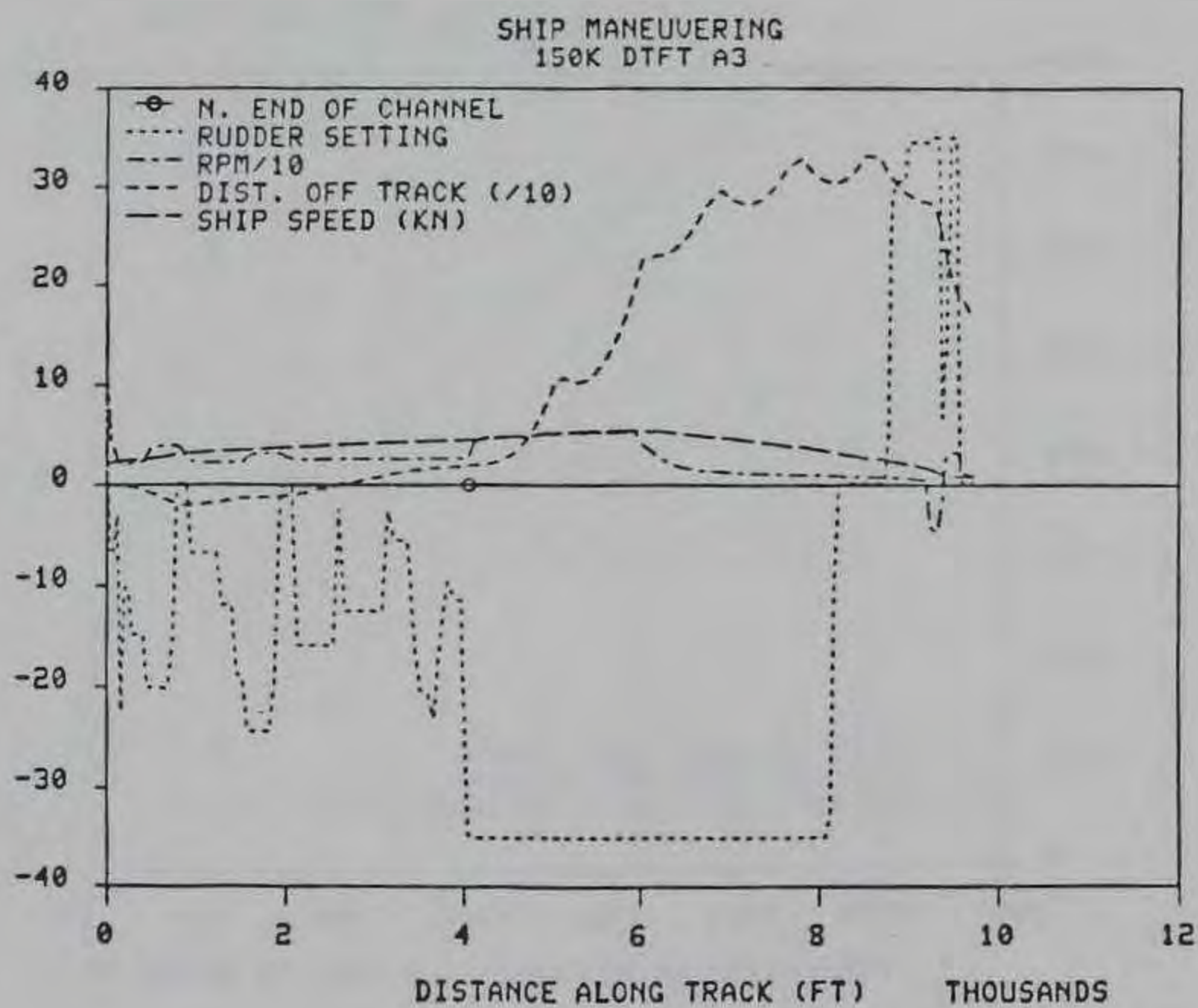
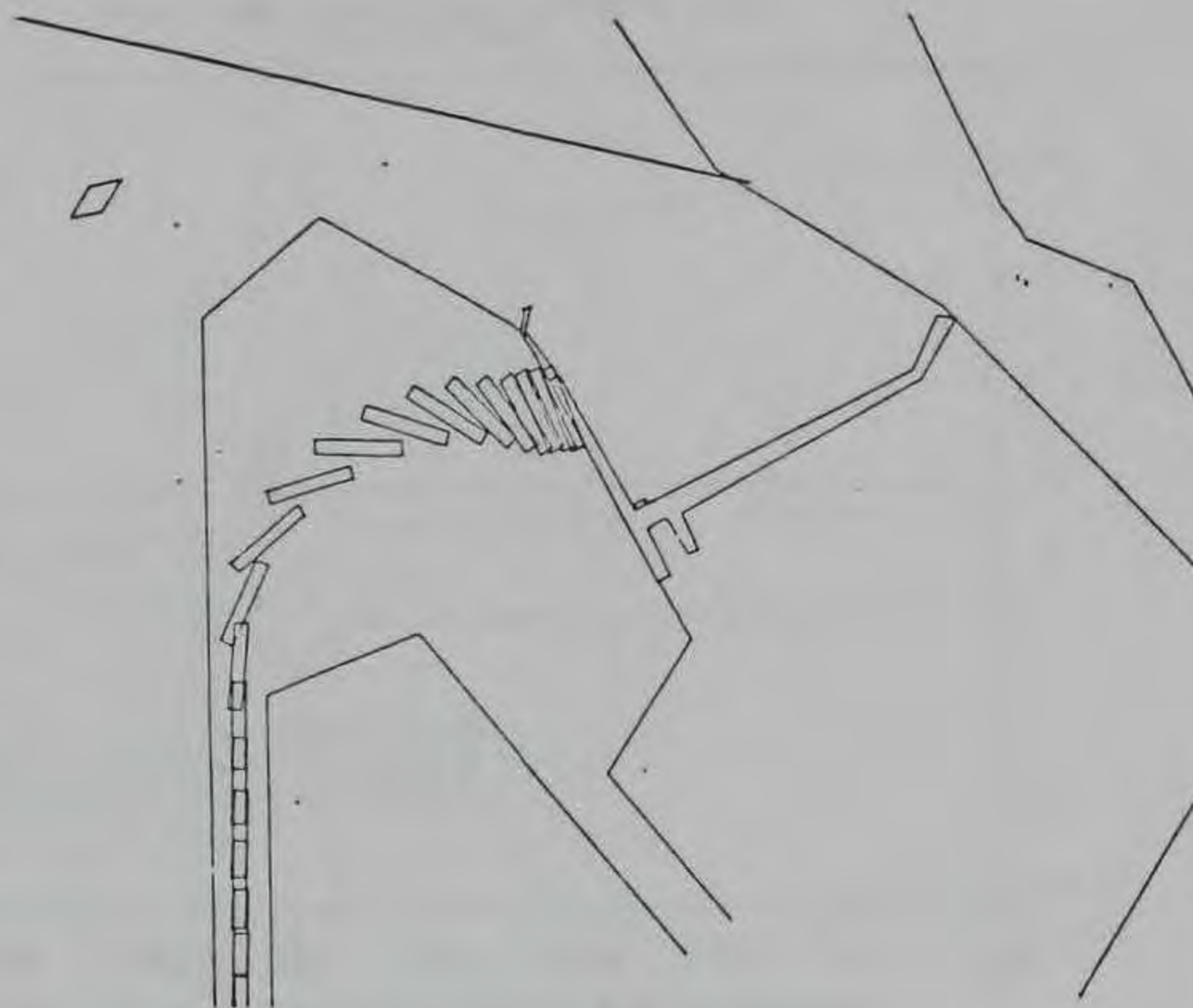

Figure A13. Ship maneuvering, 150K DTFT A3

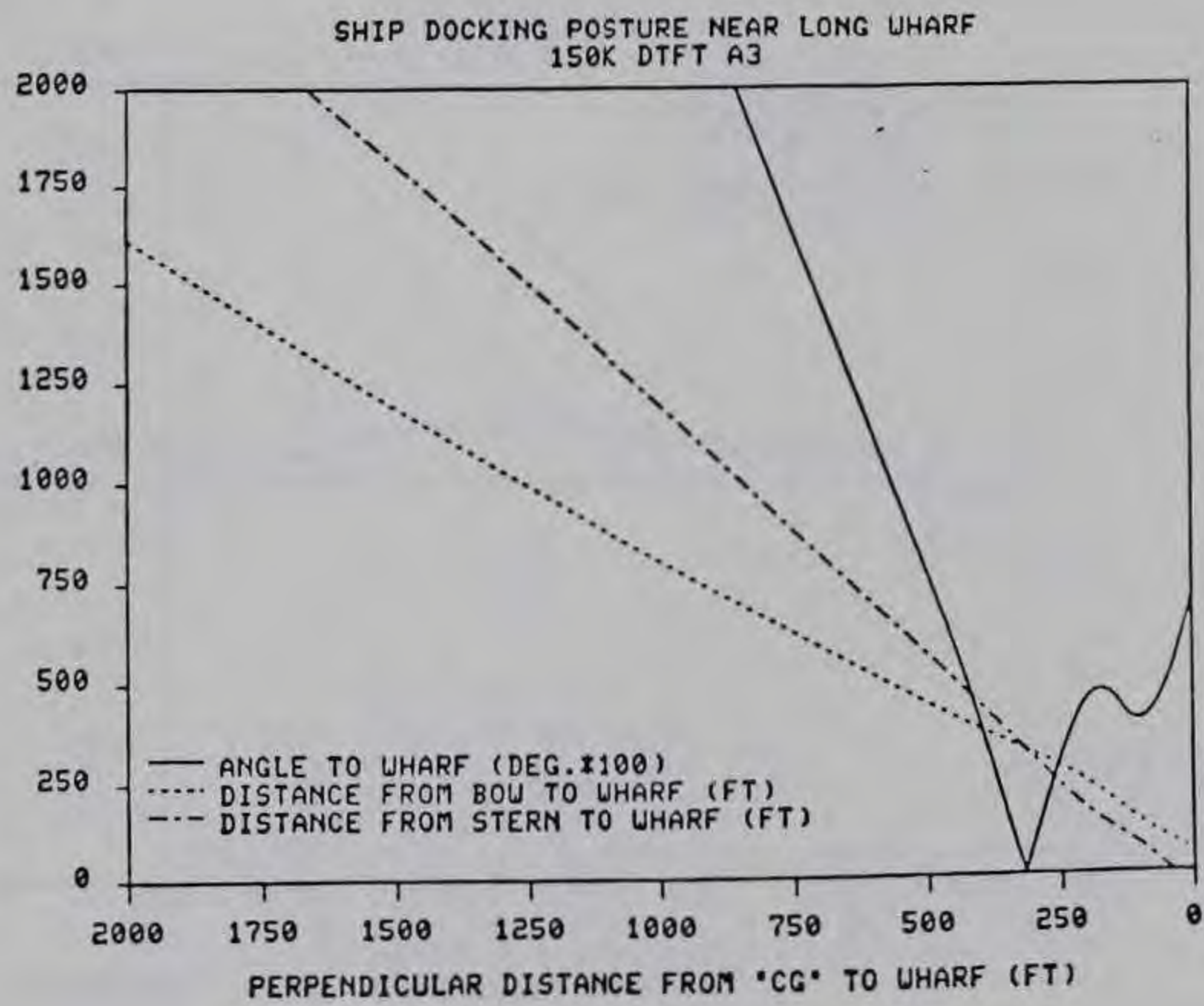
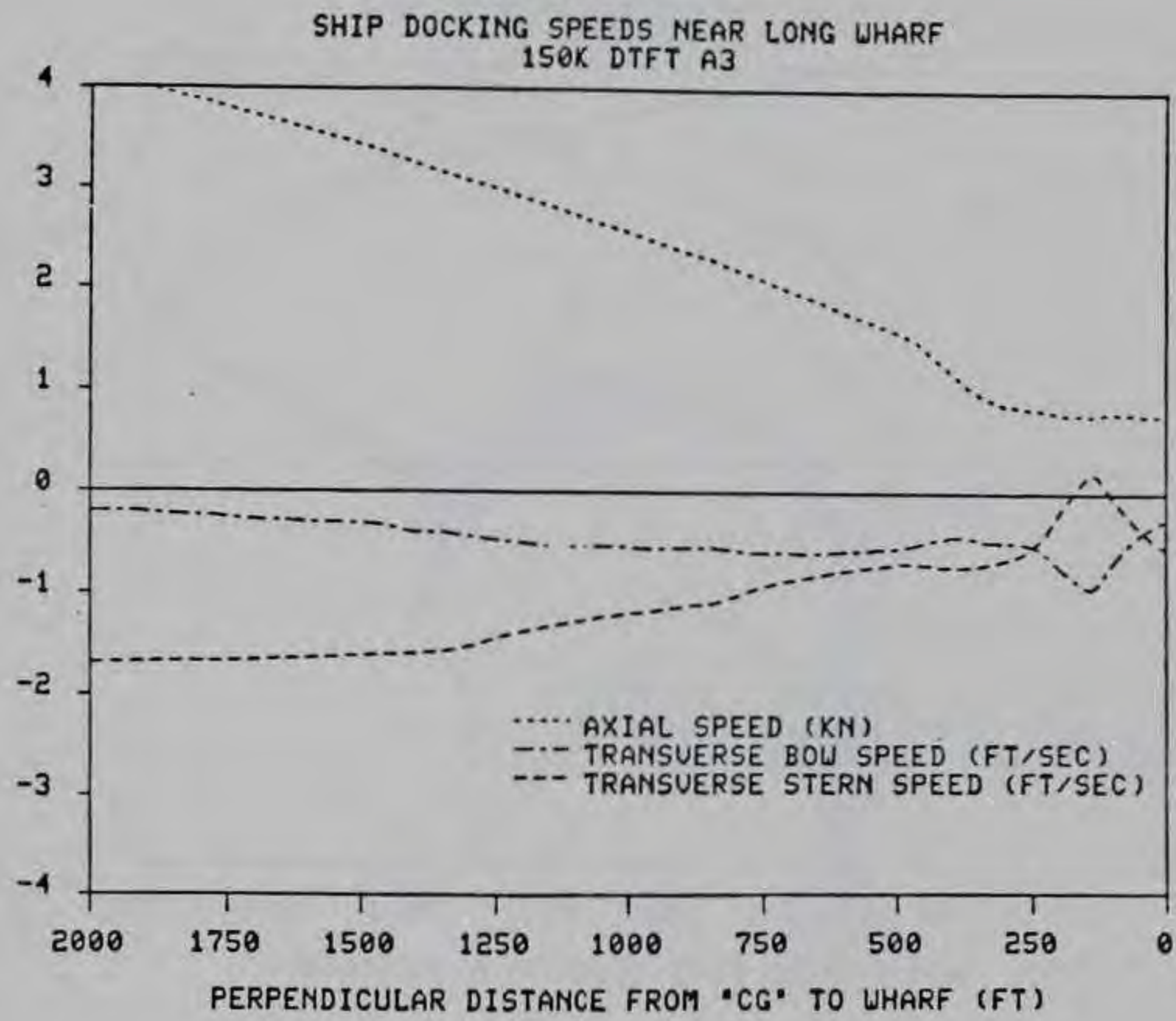

Figure A14. Ship docking speed and posture, 150K DTFT A3

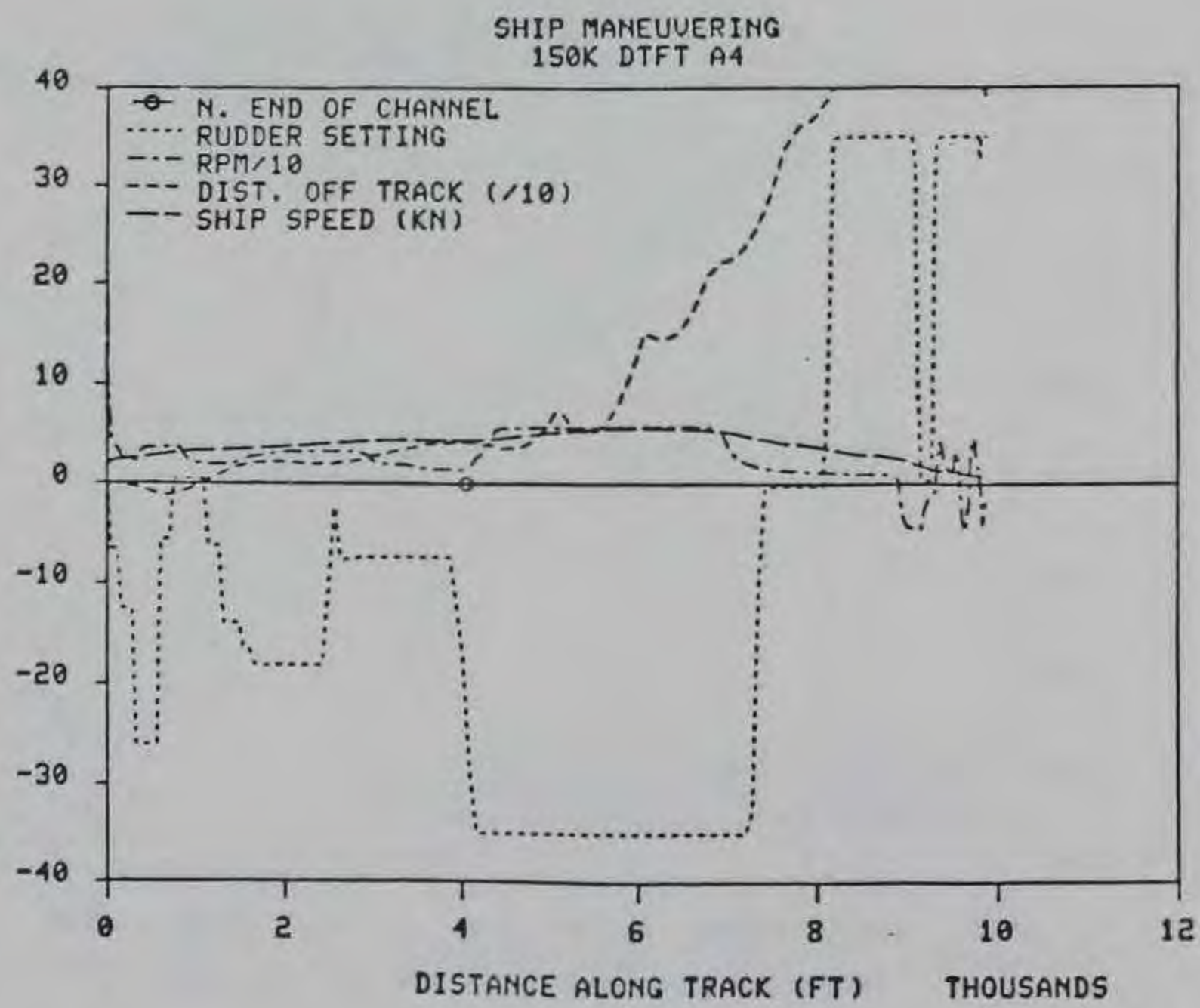
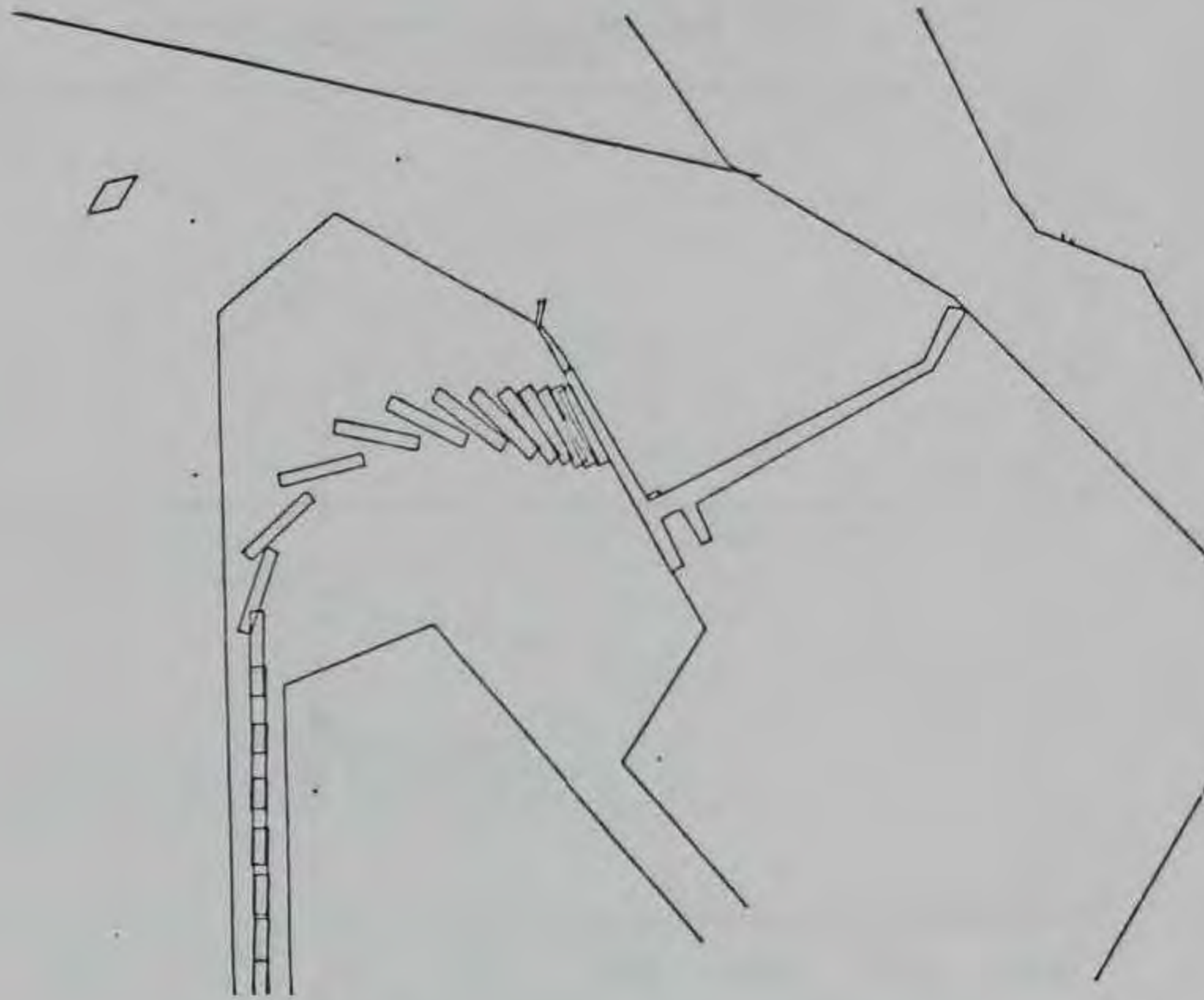

Figure A15. Ship maneuvering, 150K DTFT A4

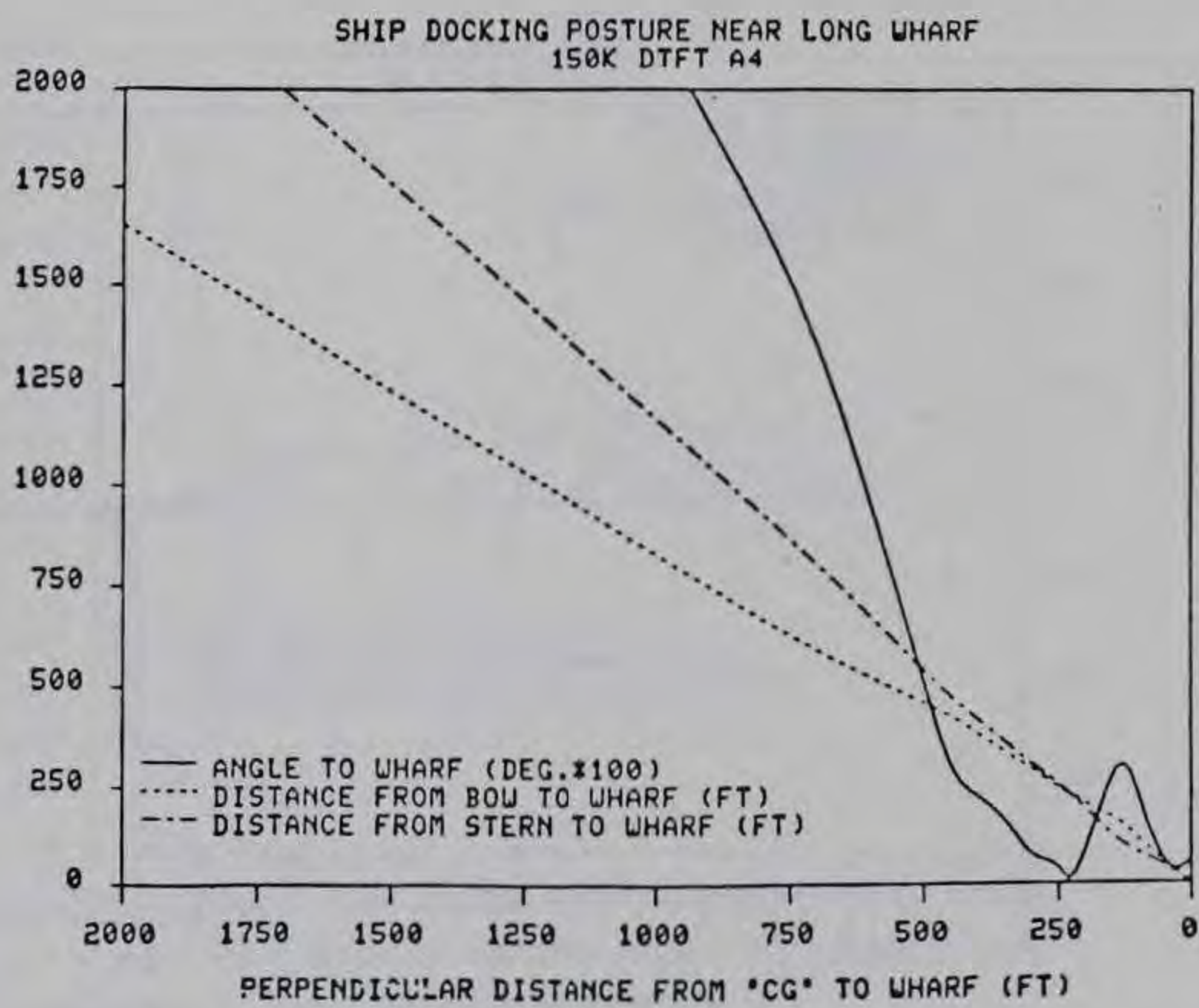
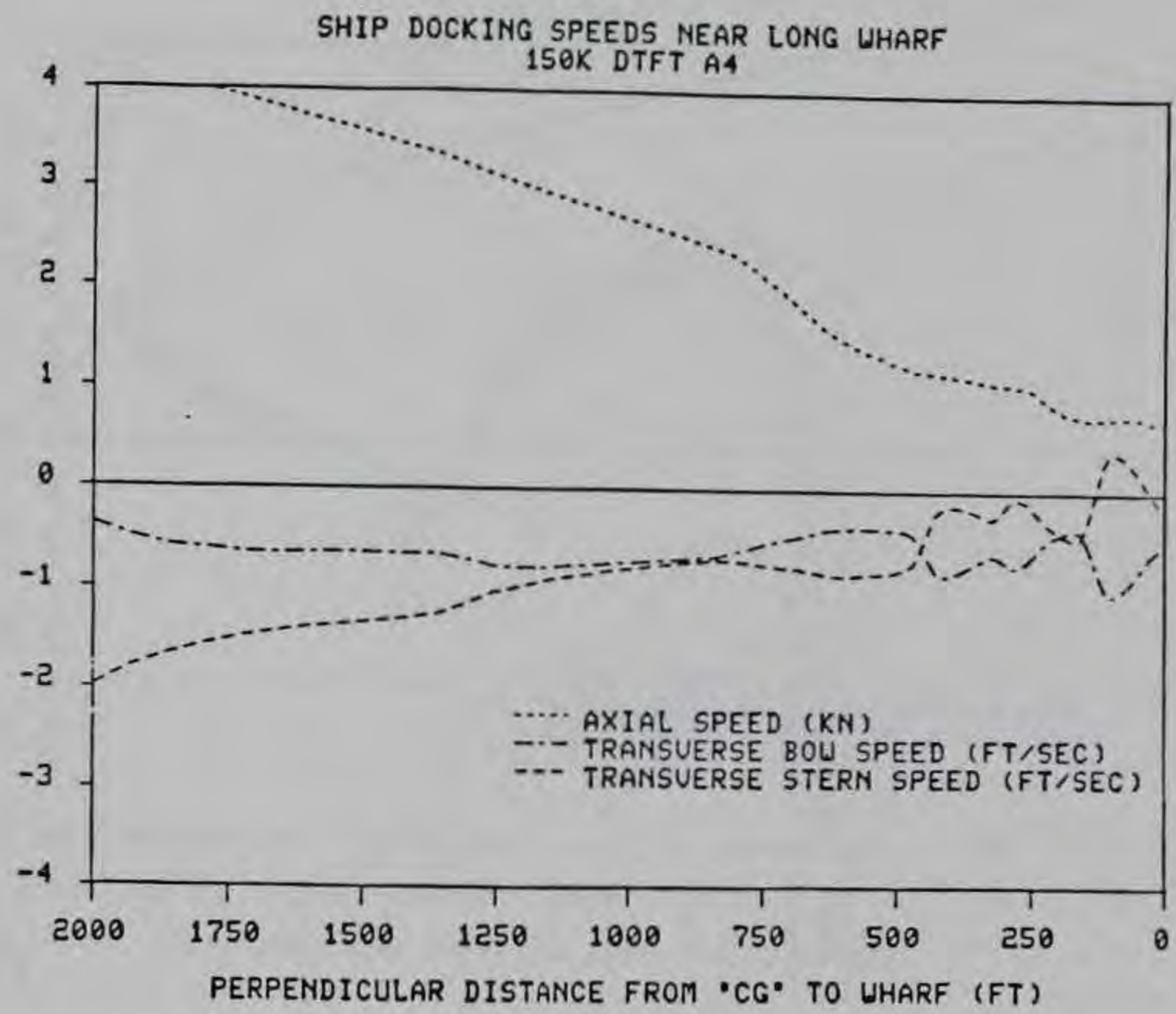

Figure A16. Ship docking speed and posture, 150K DTFT A4

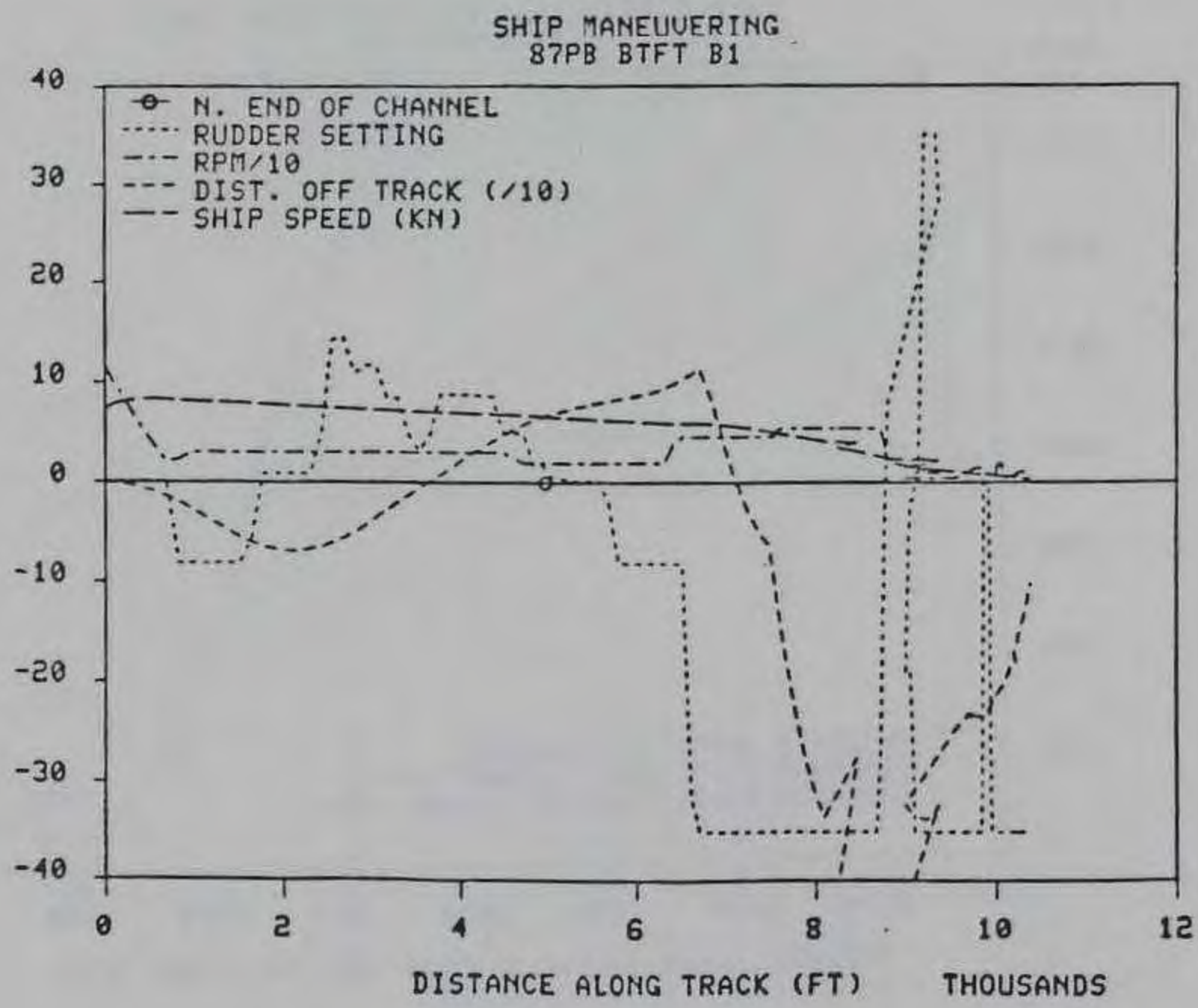
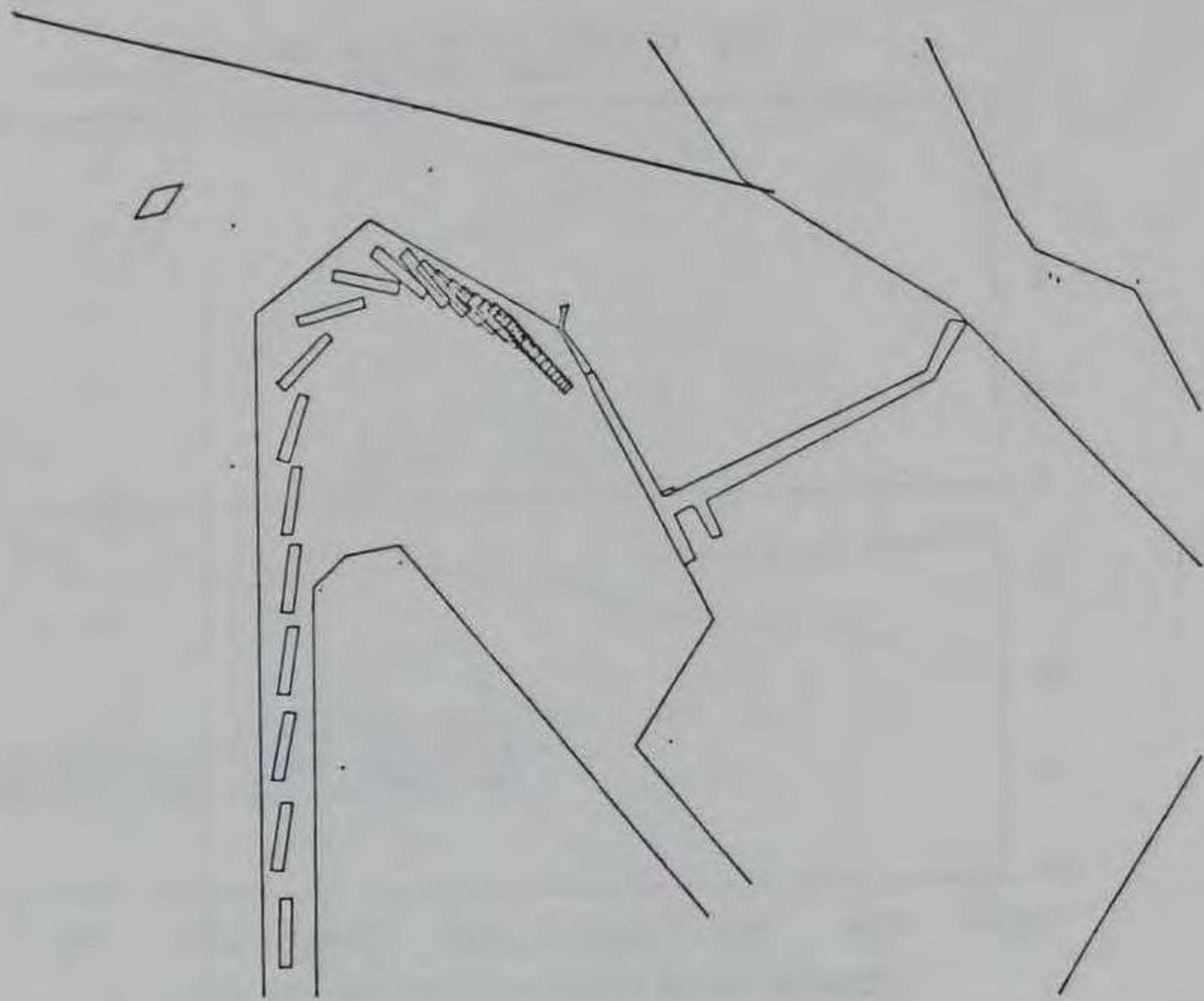

Figure A17. Ship maneuvering, 87PB BTFT B1

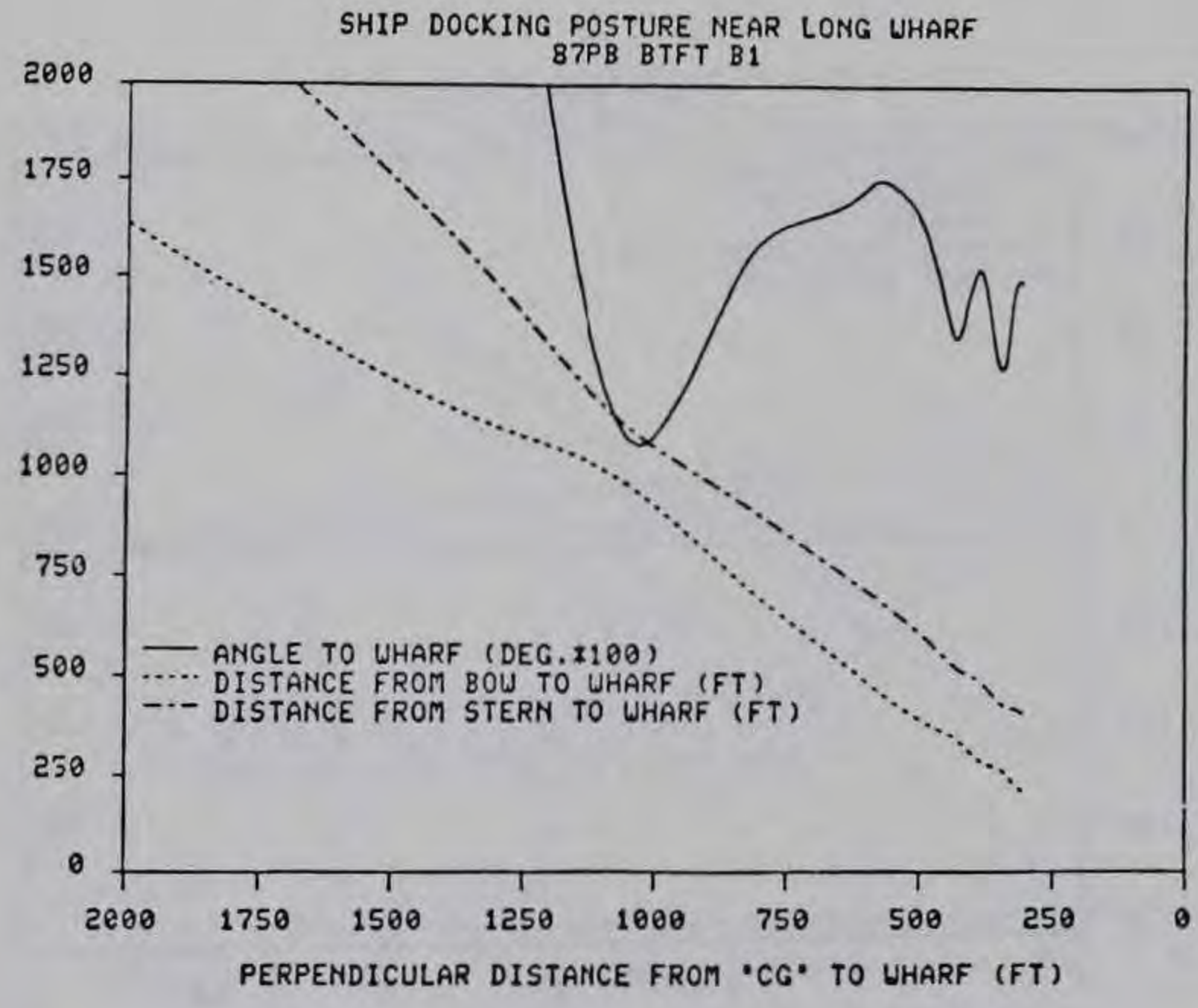
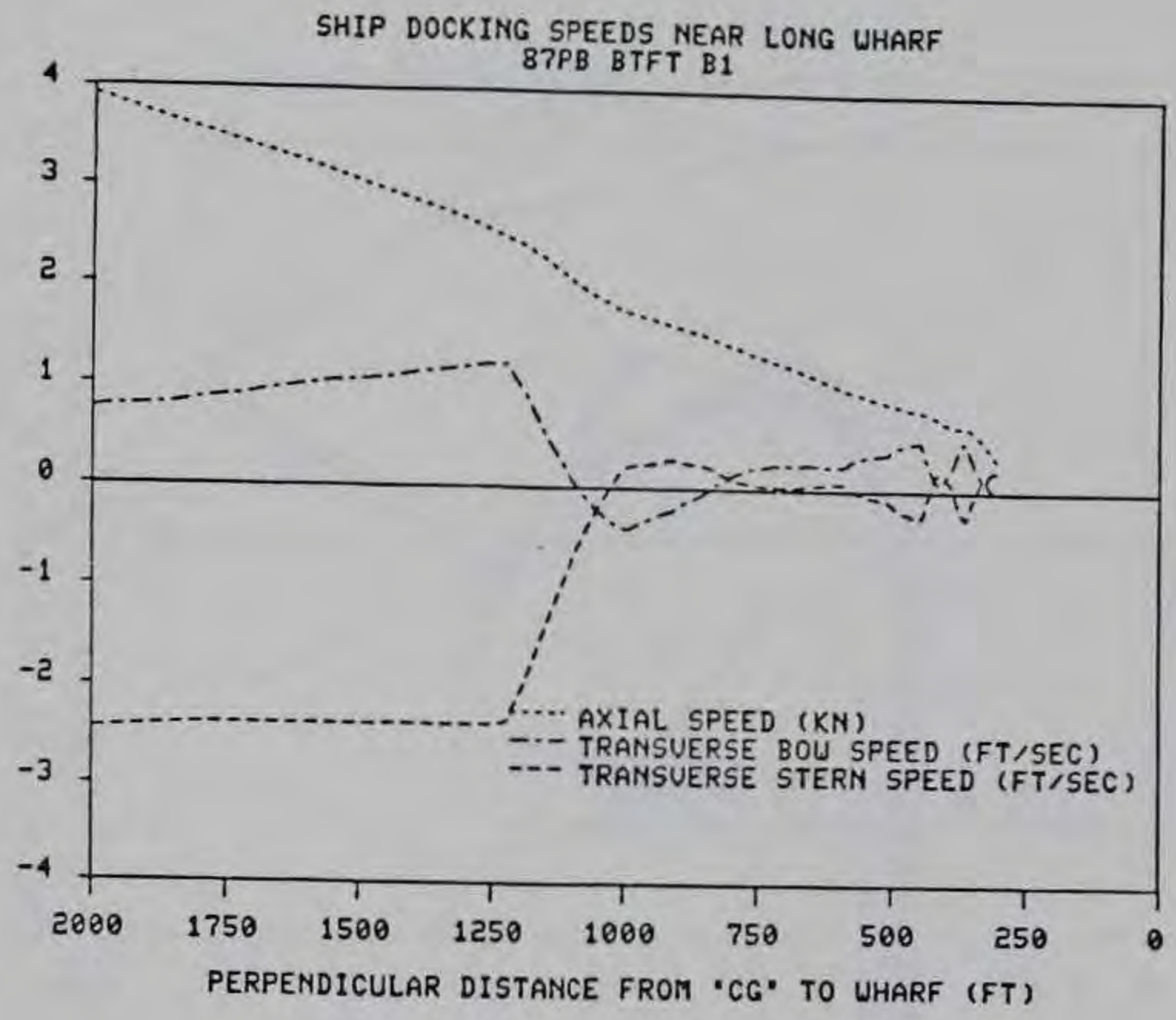

Figure A18. Ship docking speed and posture, 87PB BTFT B1

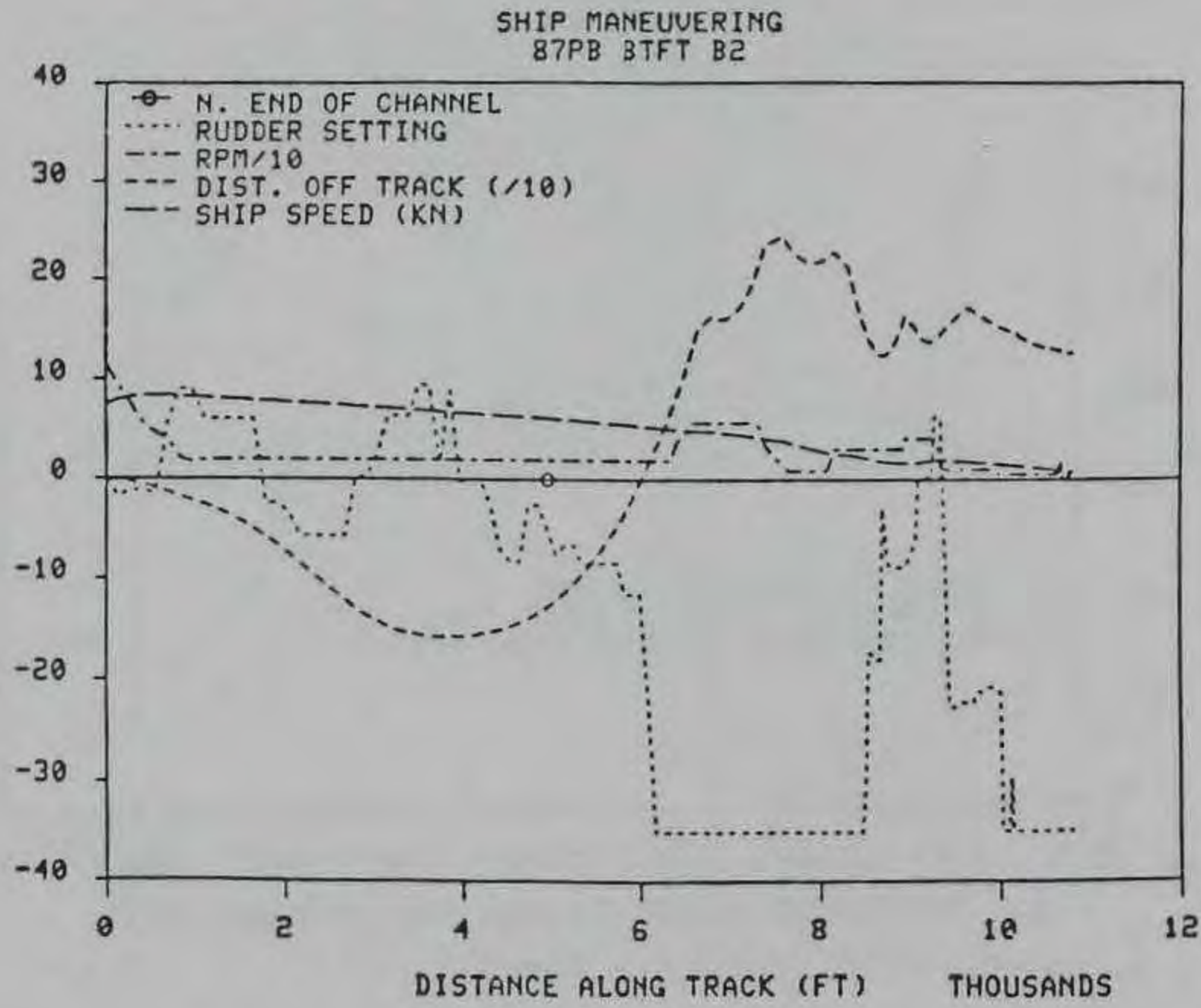

Figure A19. Ship maneuvering, 87PB BTFT B2

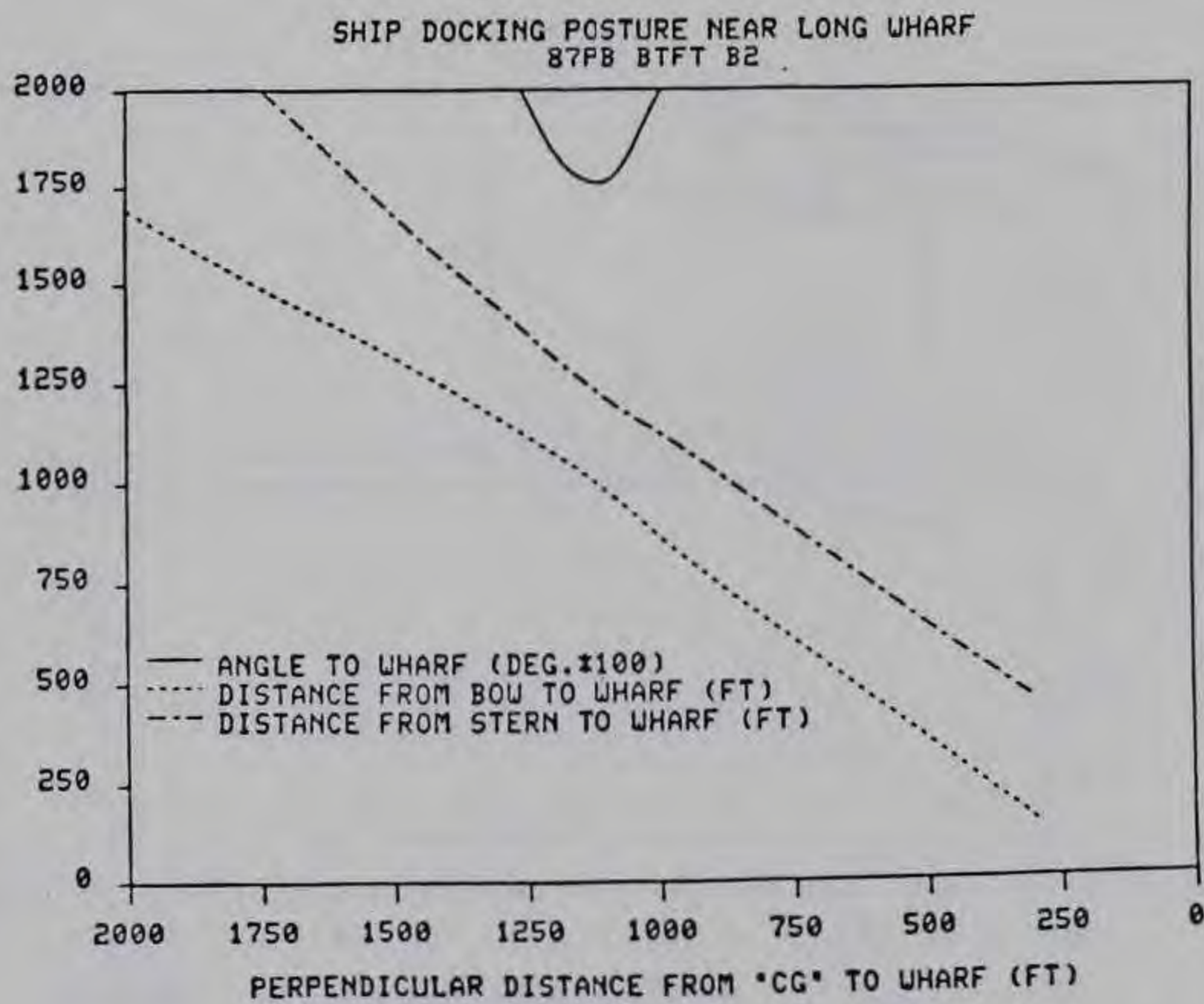
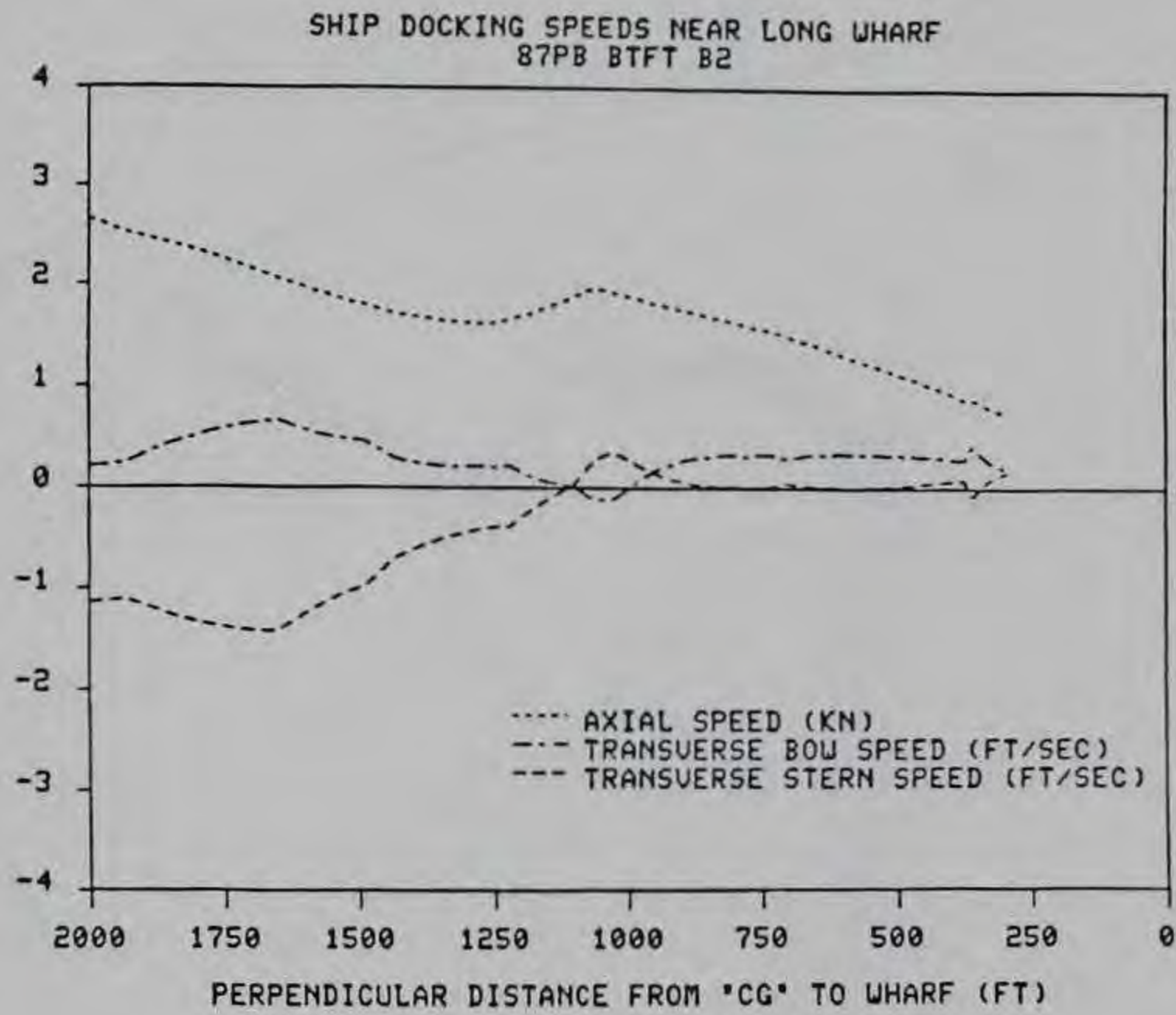

Figure A20. Ship docking speed and posture, 87PB BTFT B2

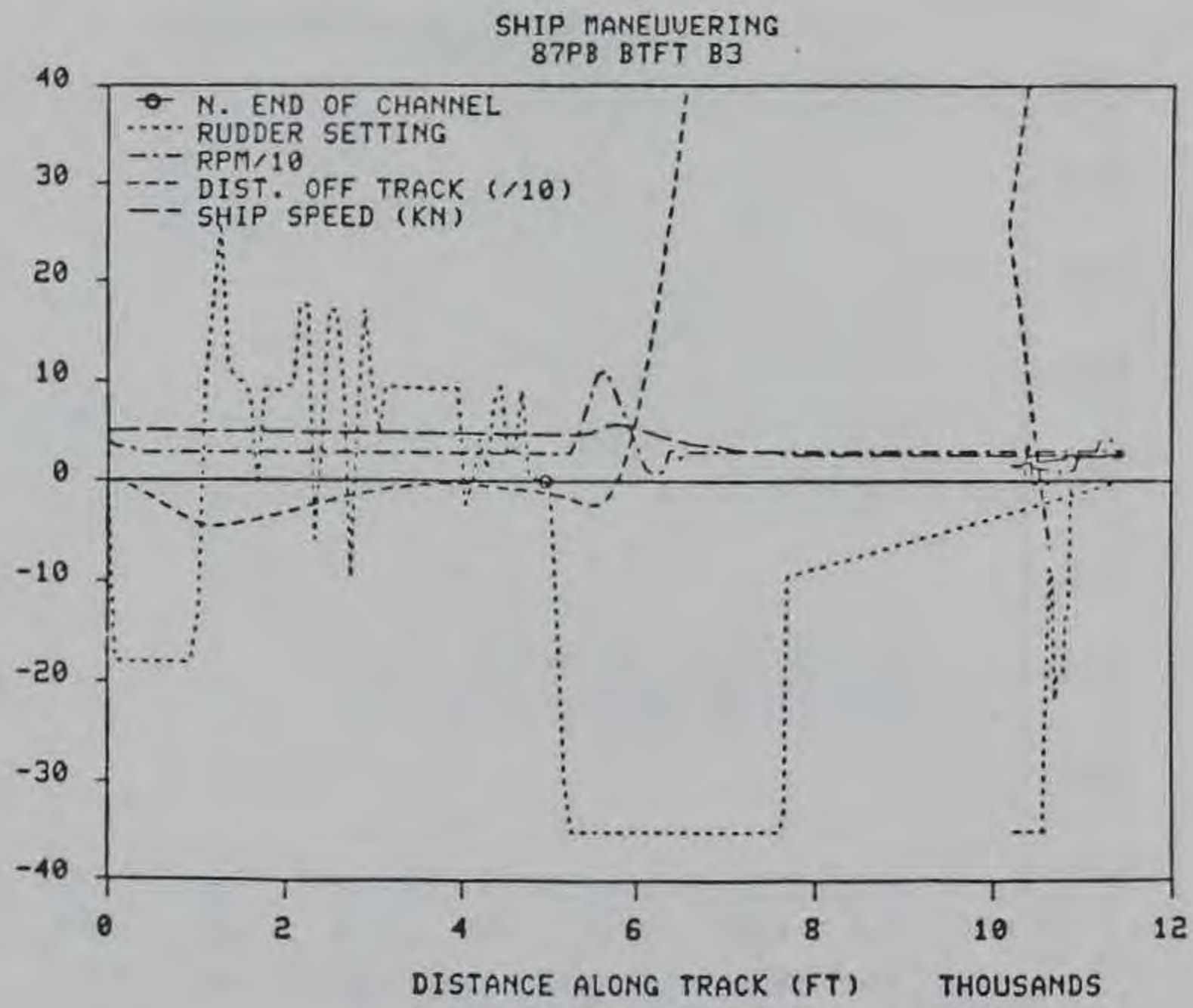
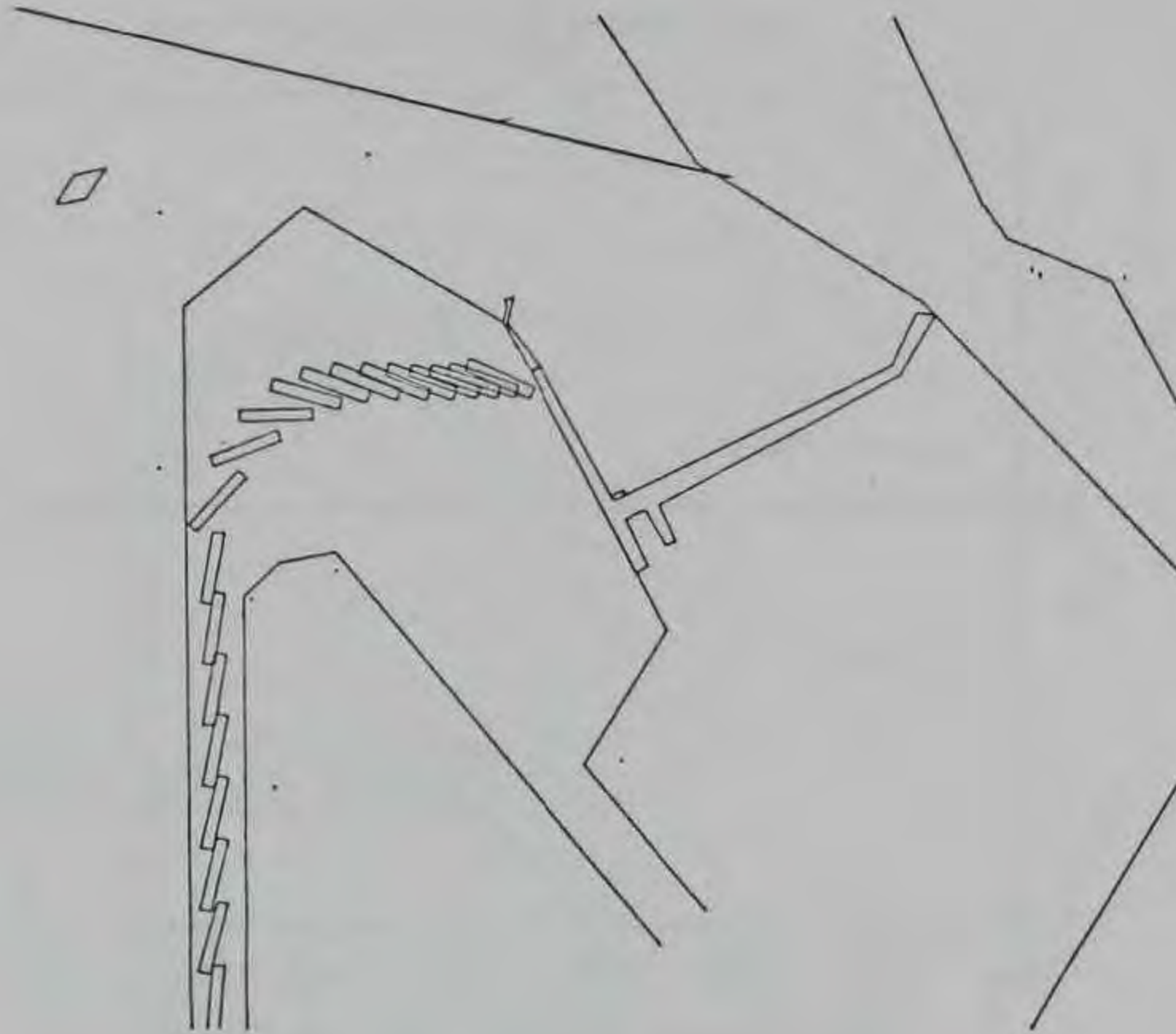

Figure A21. Ship maneuvering, 87PB BTFT B3

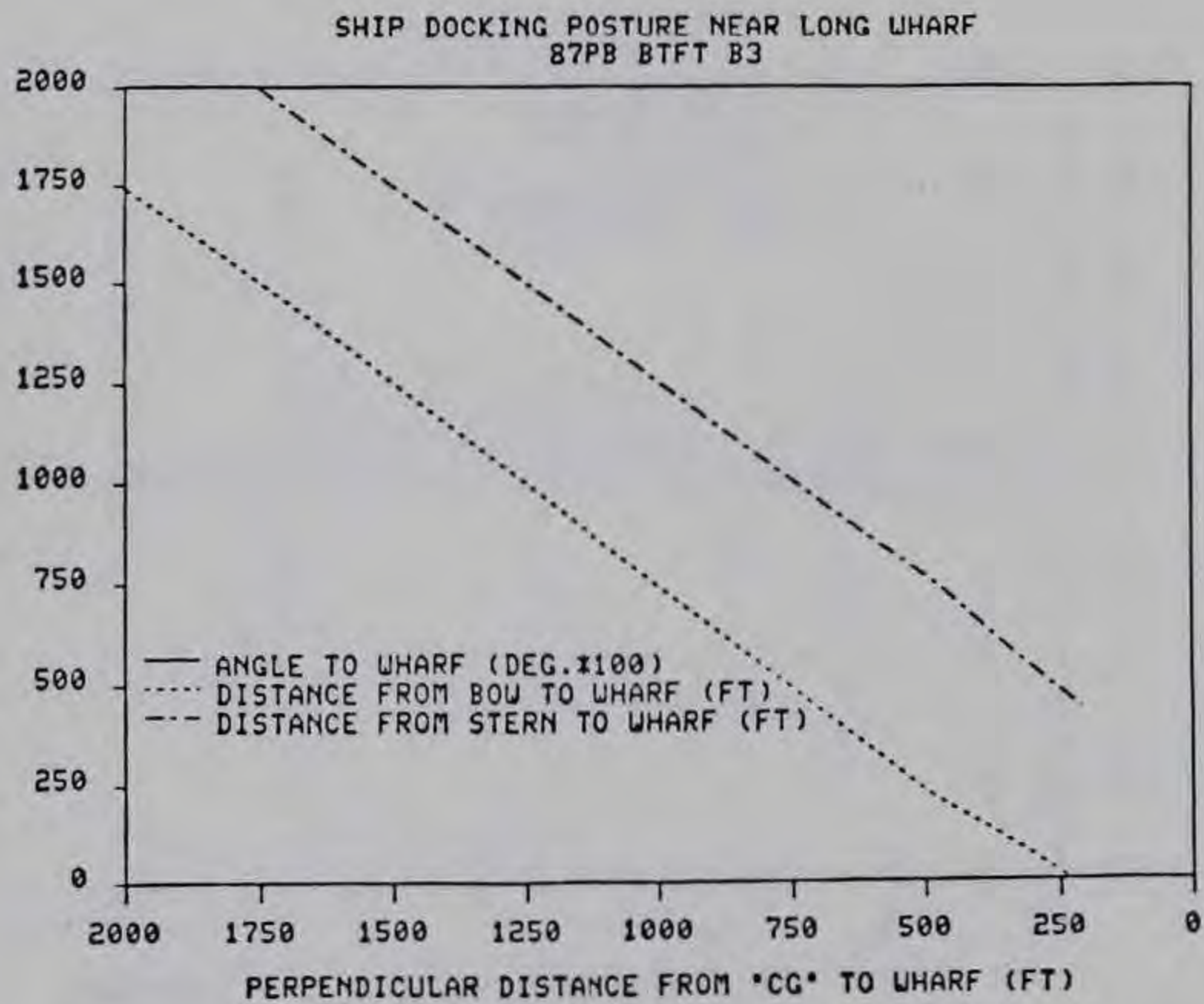
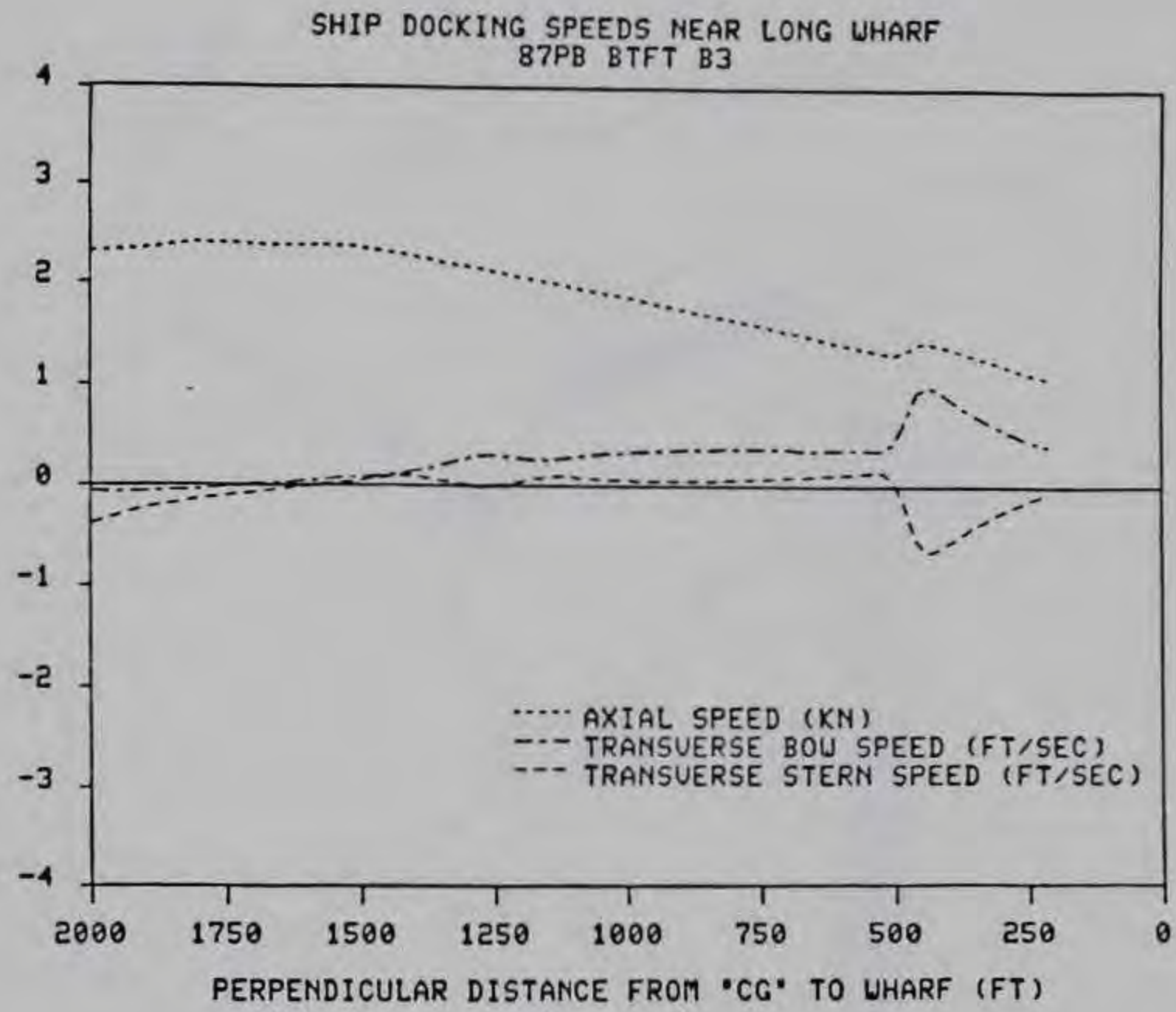

Figure A22. Ship docking speed and posture, 87PB BTFT B3

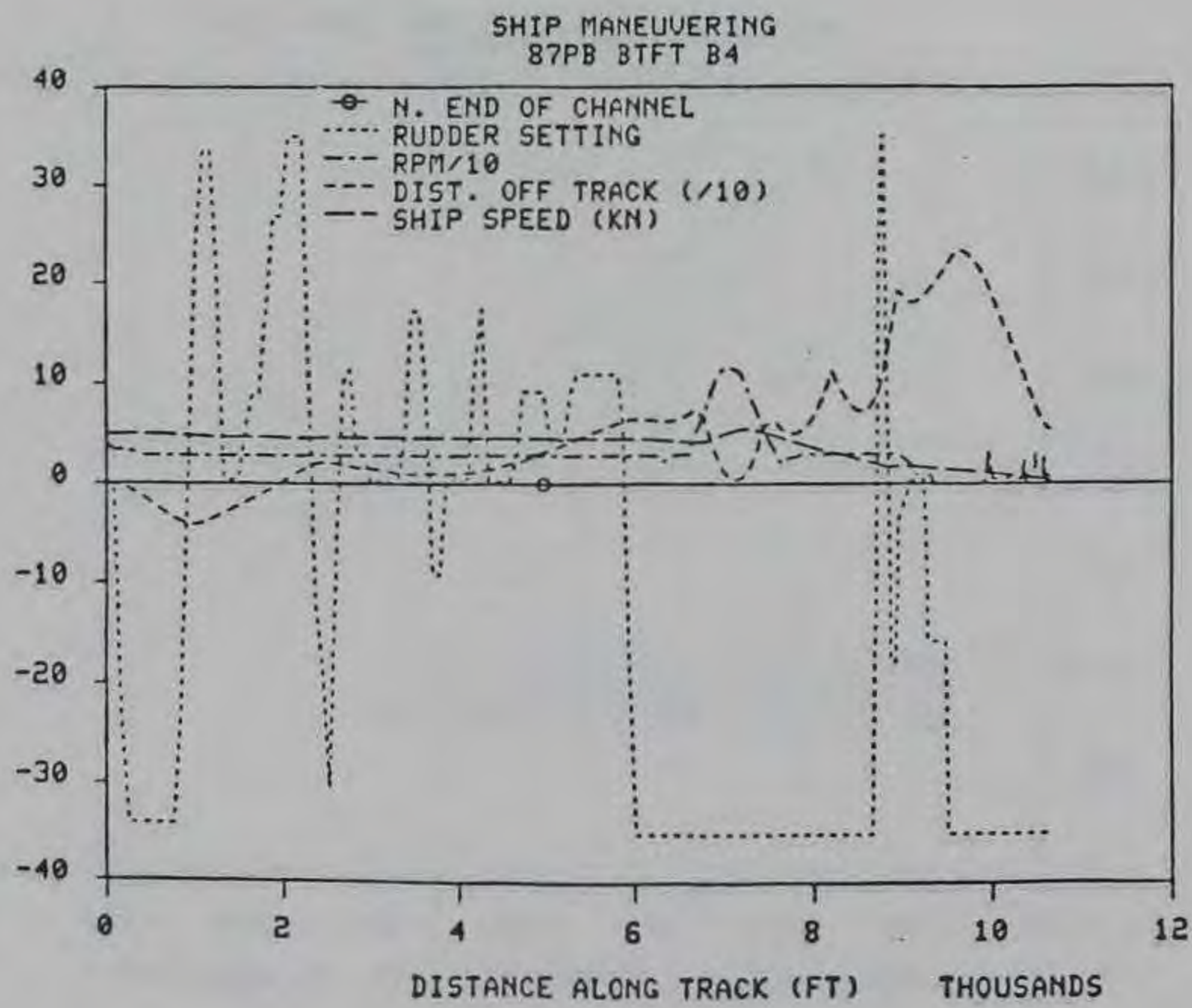

Figure A23. Ship maneuvering, 87PB BTFT B4

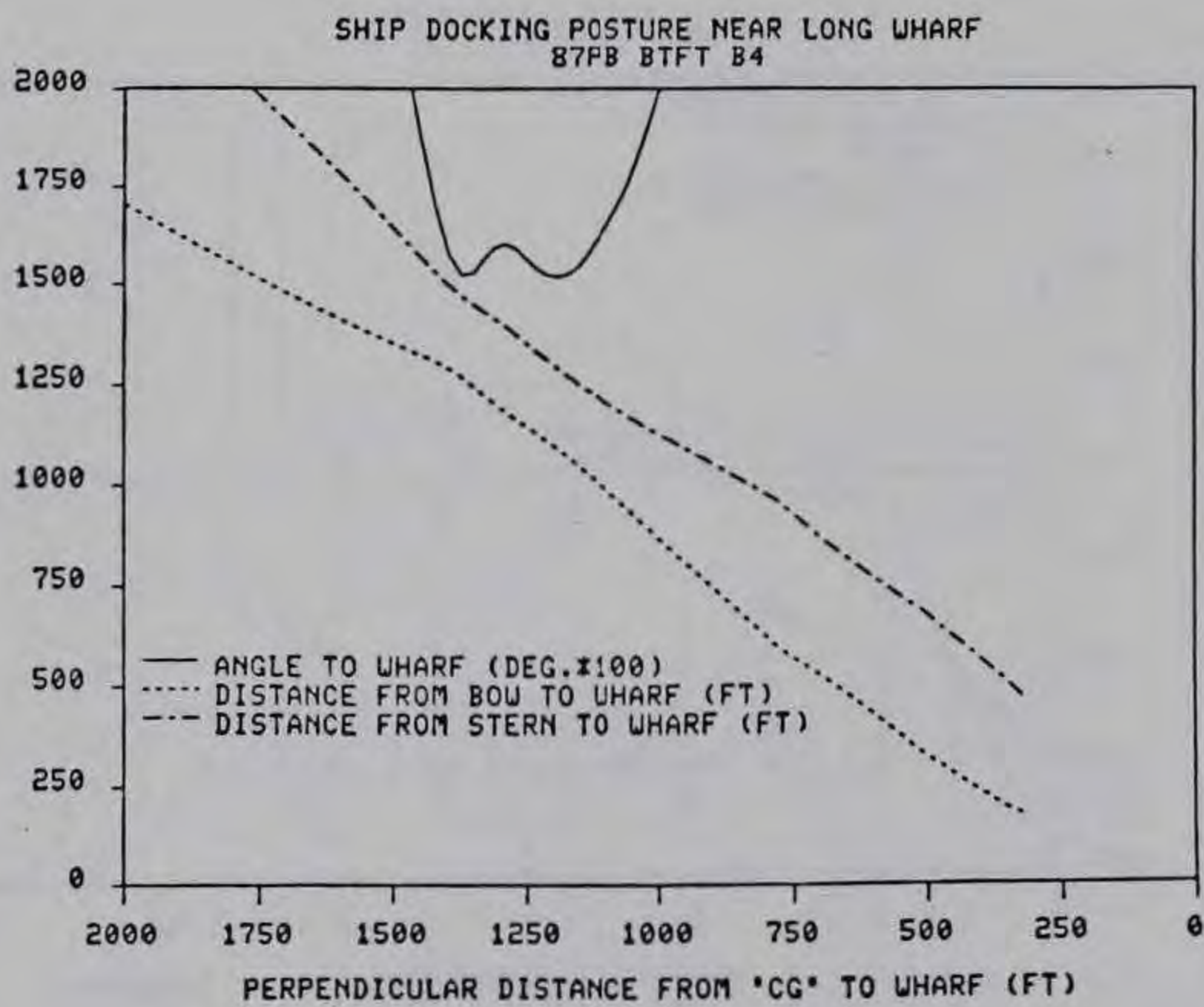
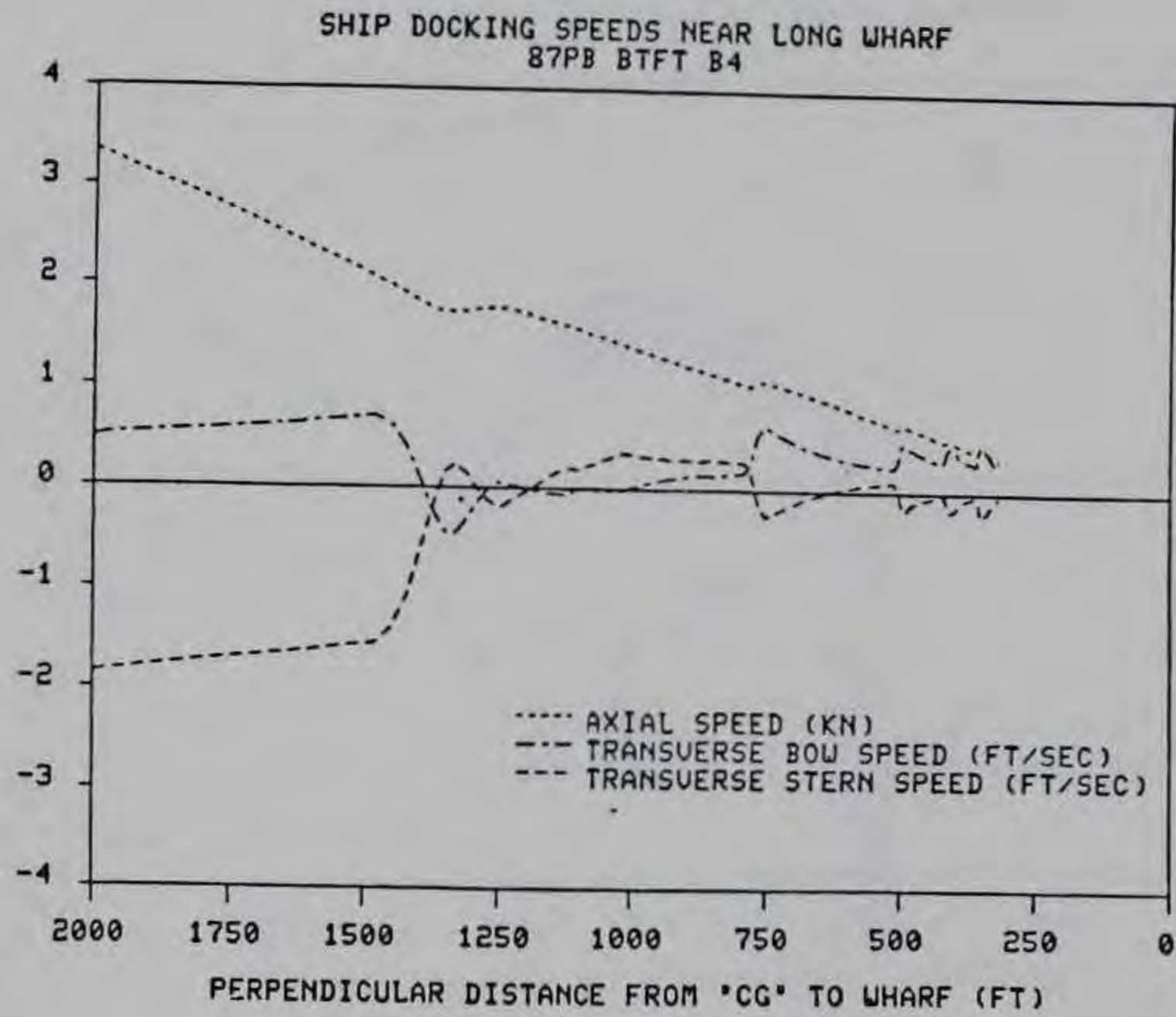

Figure A24. Ship docking speed and posture, 87PB BTFT B4

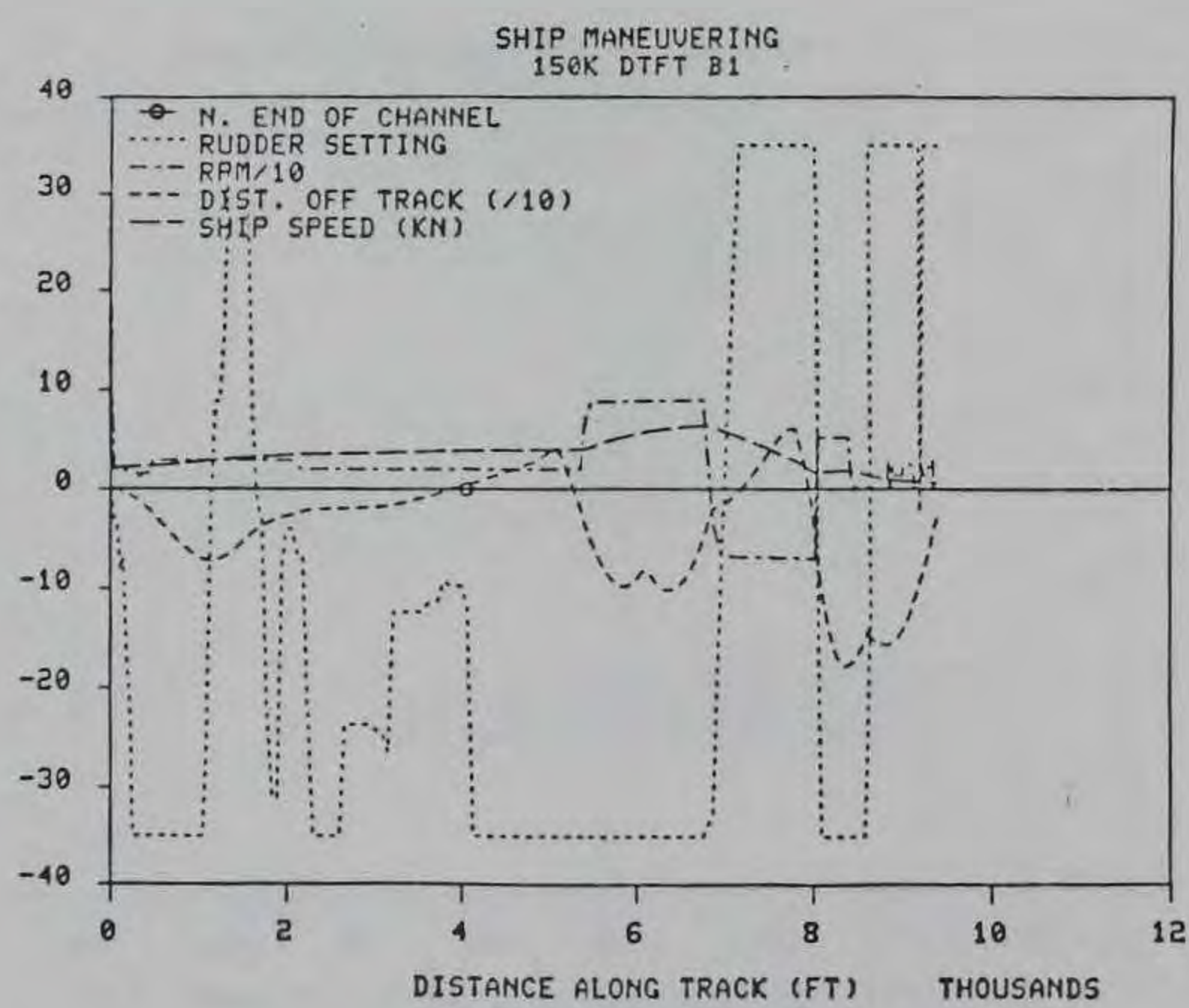
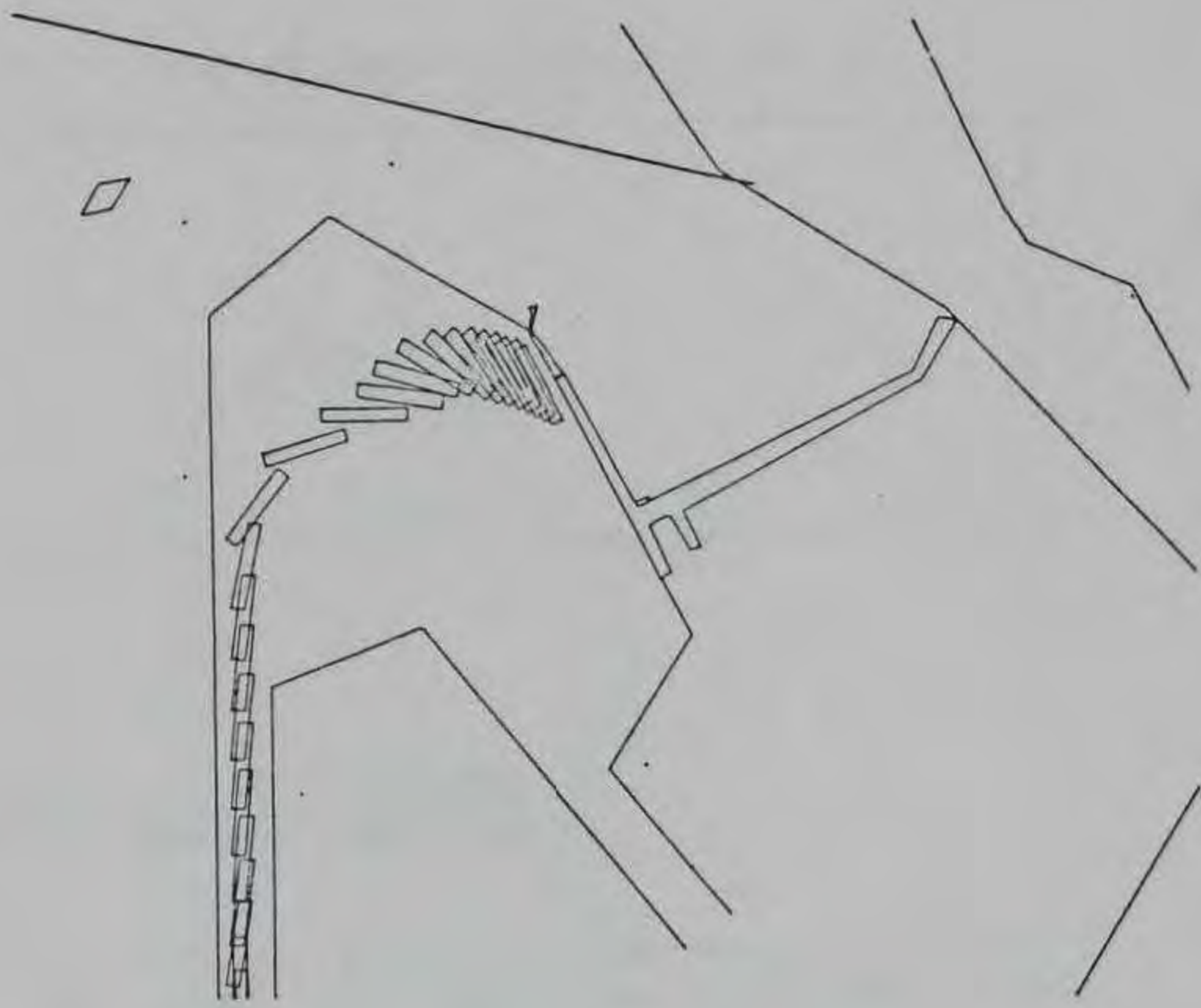

Figure A25. Ship maneuvering, 150K DTFT B1

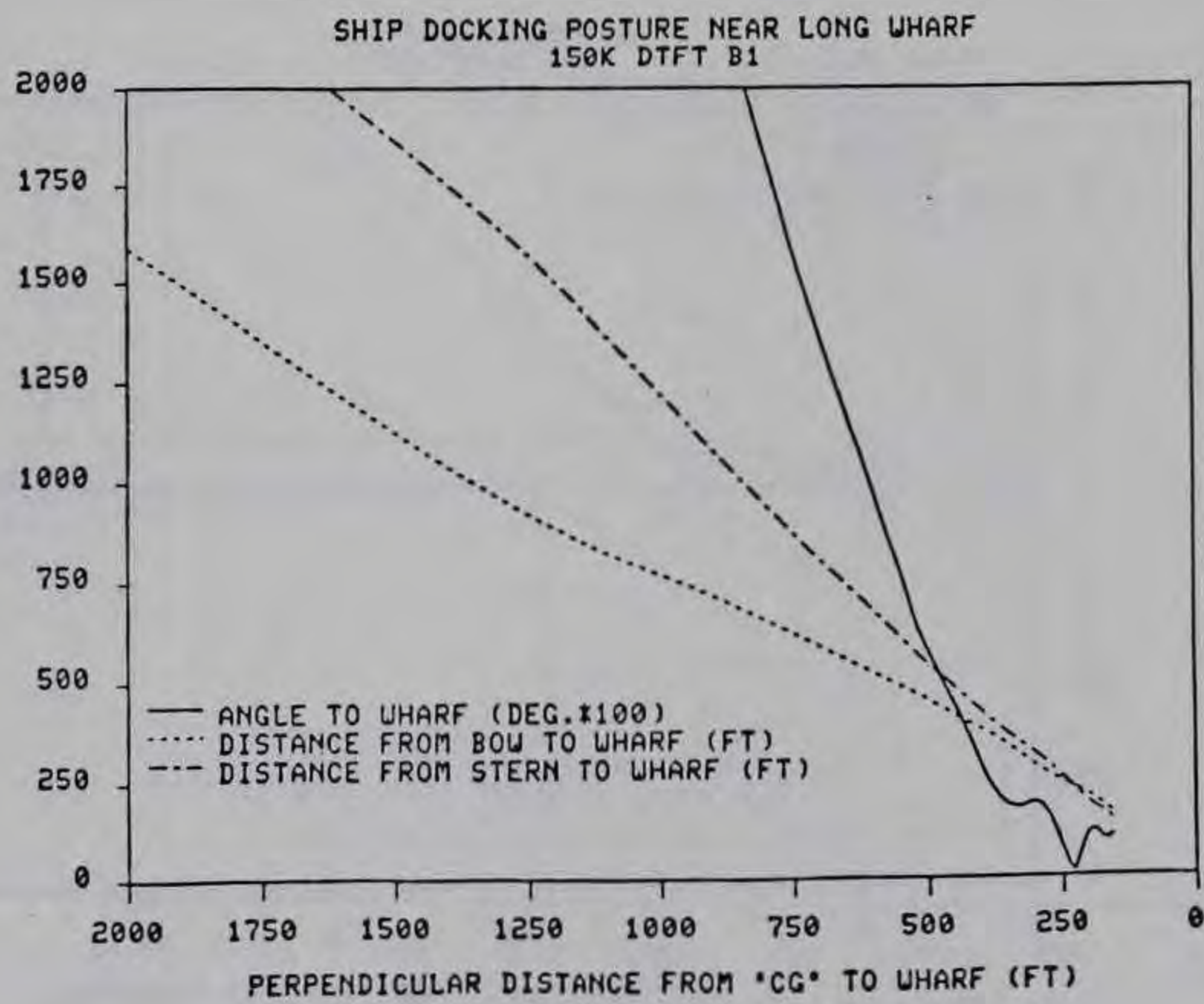
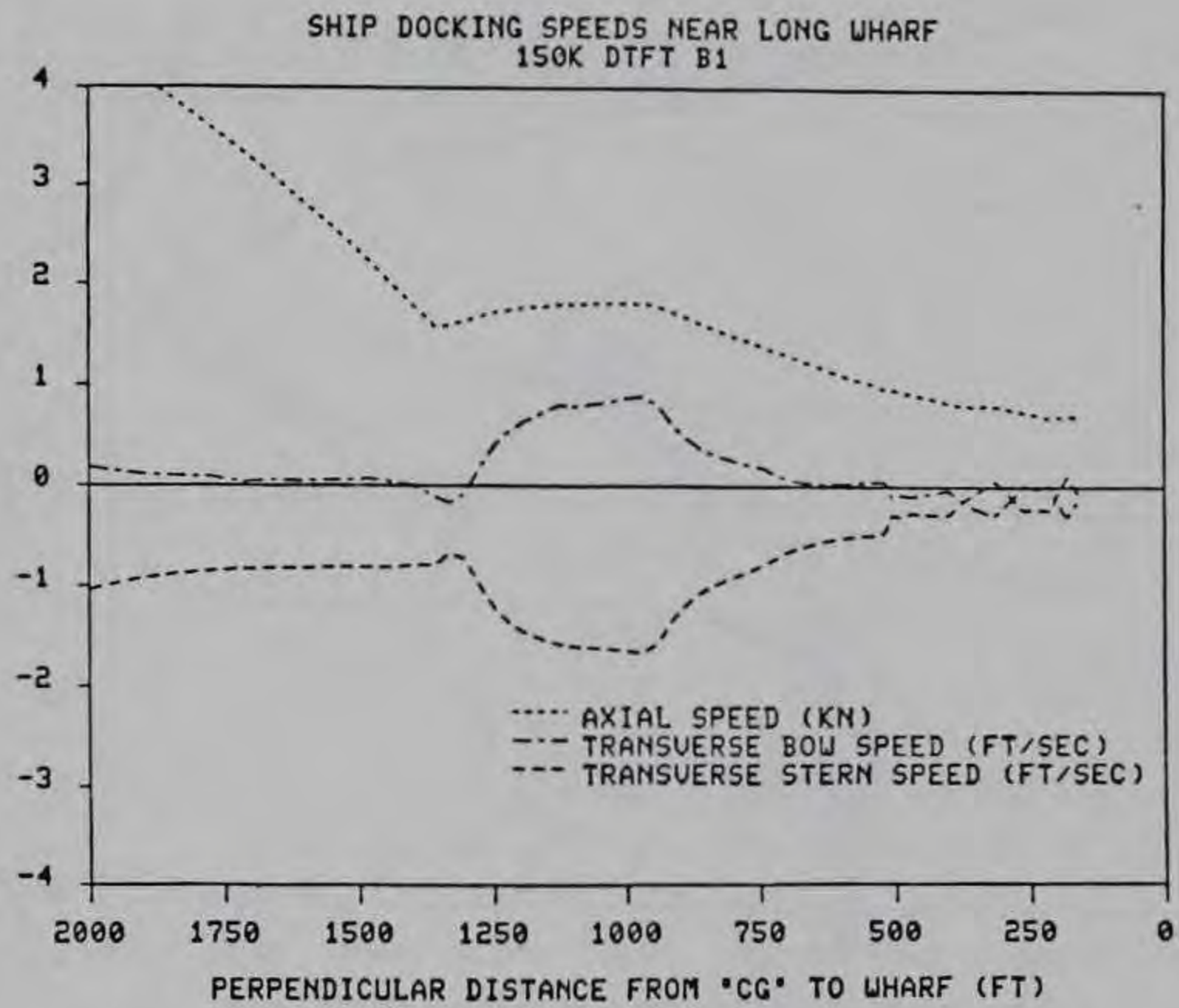

Figure A26. Ship docking speed and posture, 150K DTFT B1

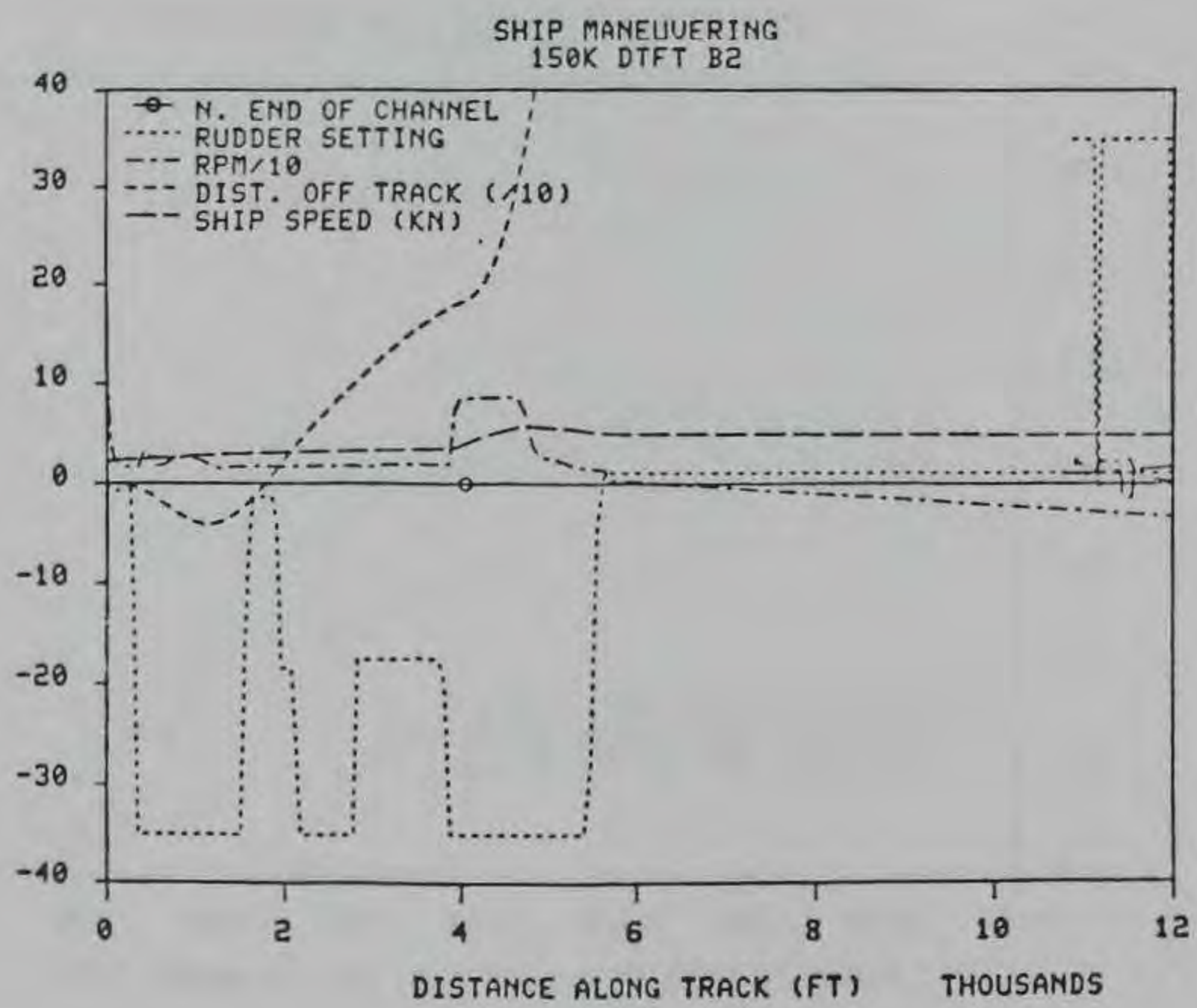
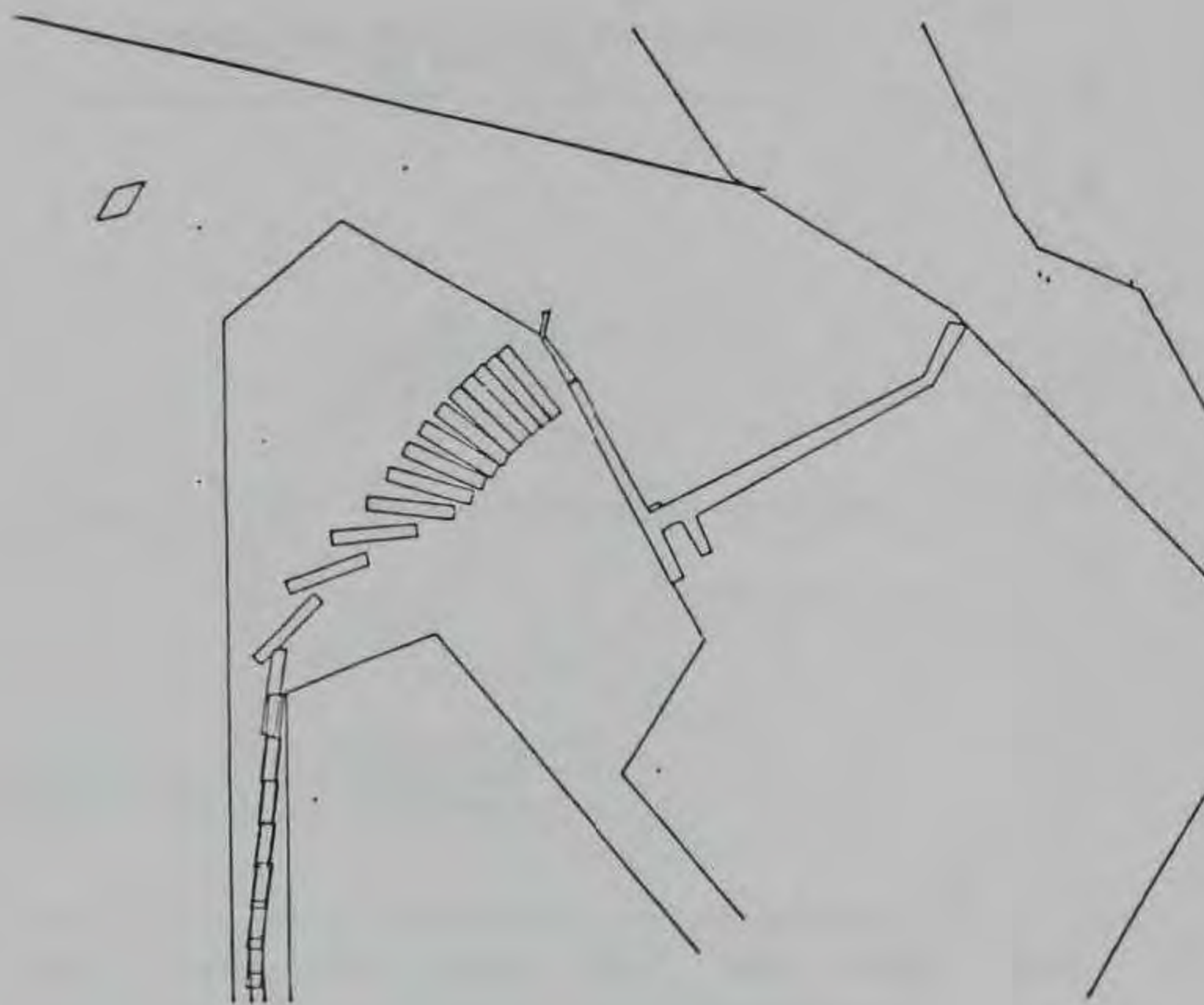

Figure A27. Ship maneuvering, 150K DTFT B2

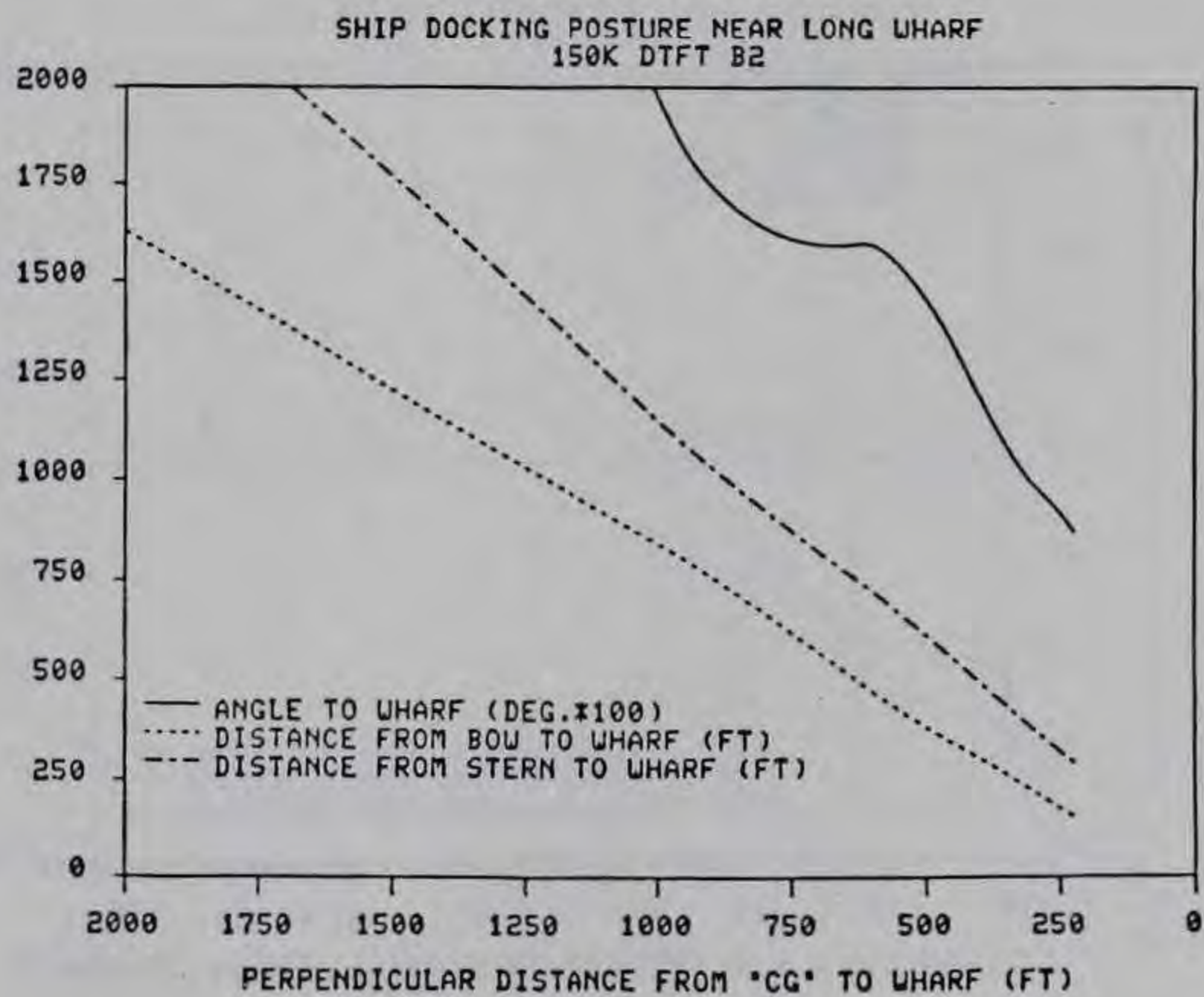
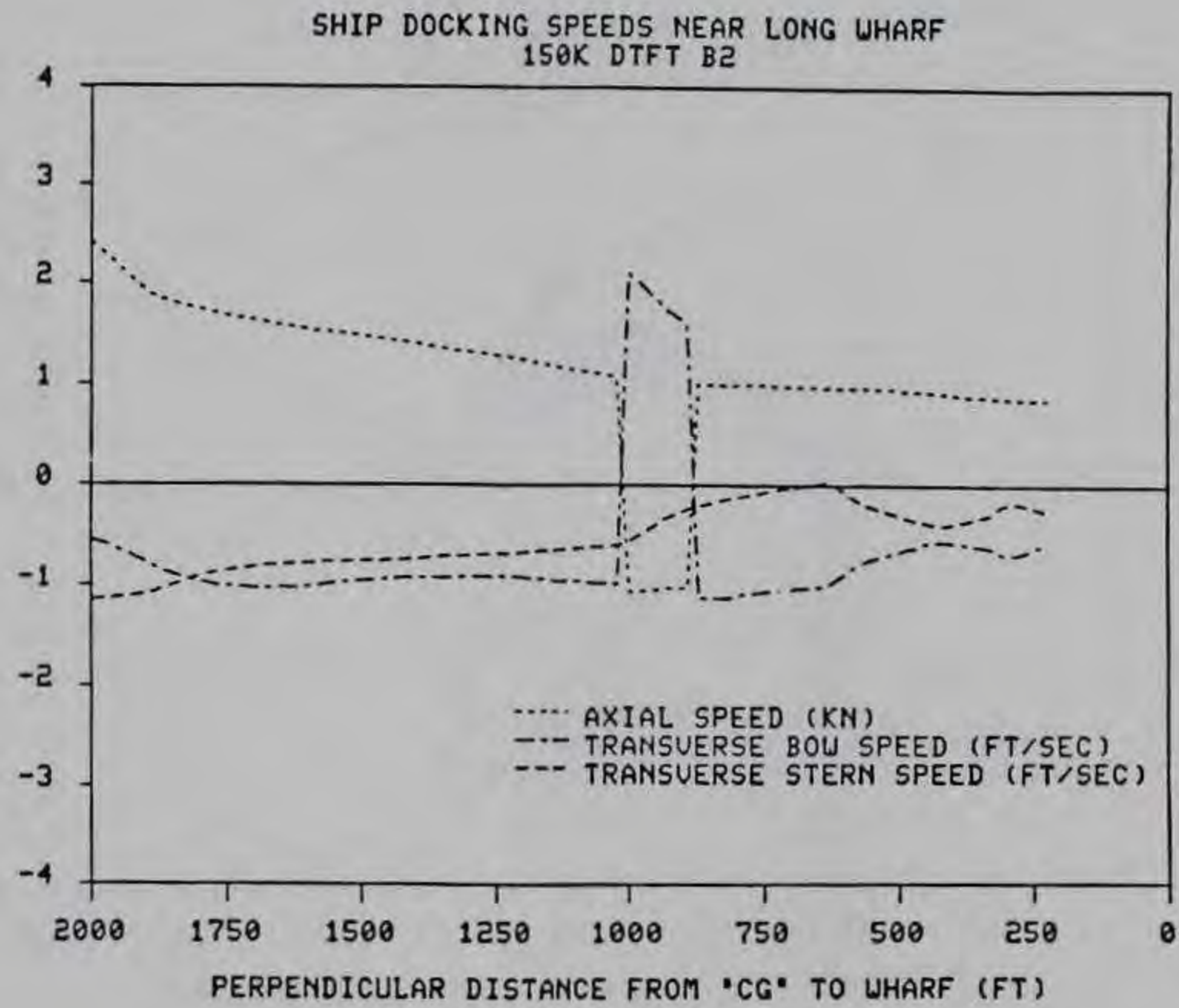

Figure A28. Ship docking speed and posture, 150K DTFT B2

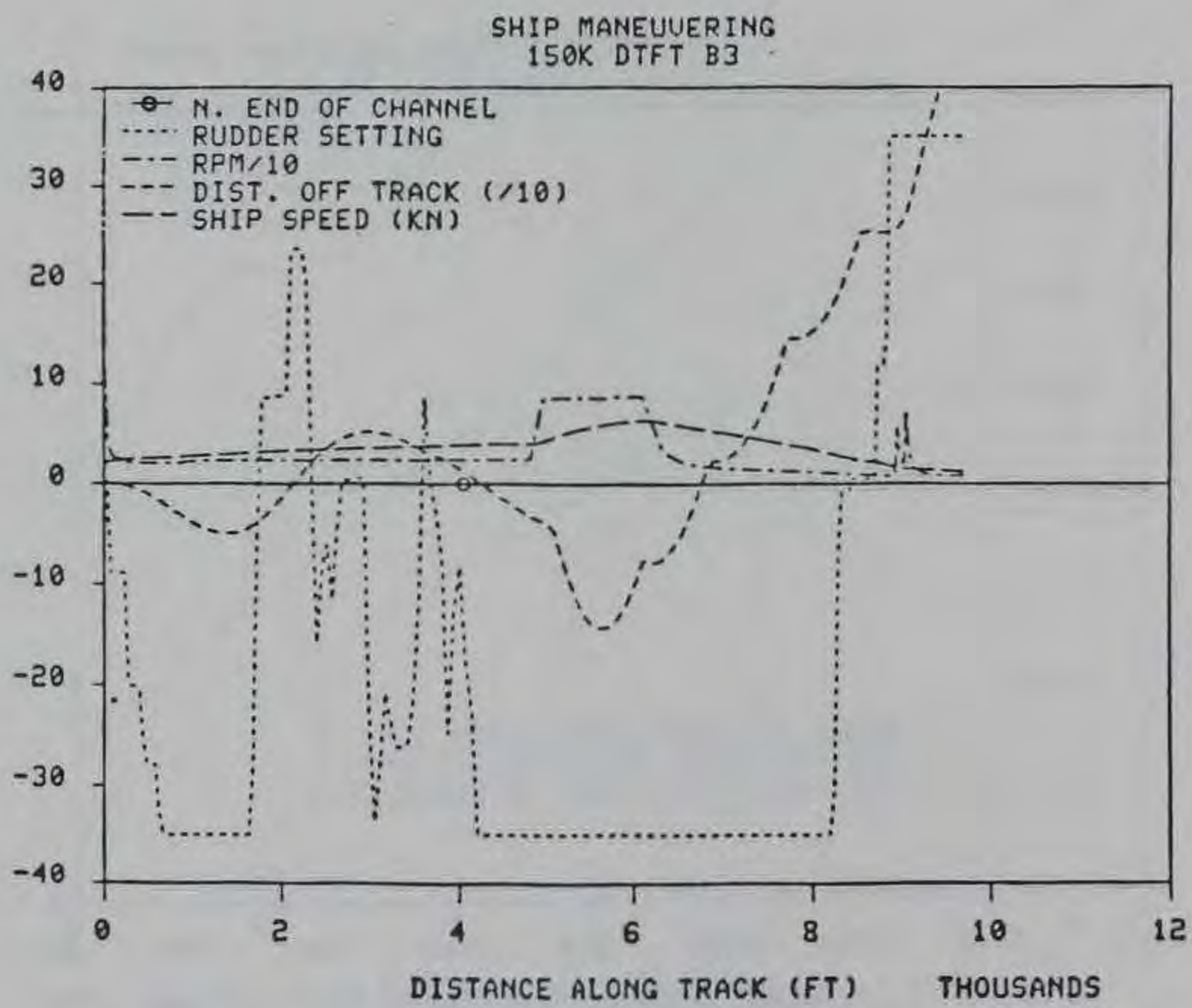
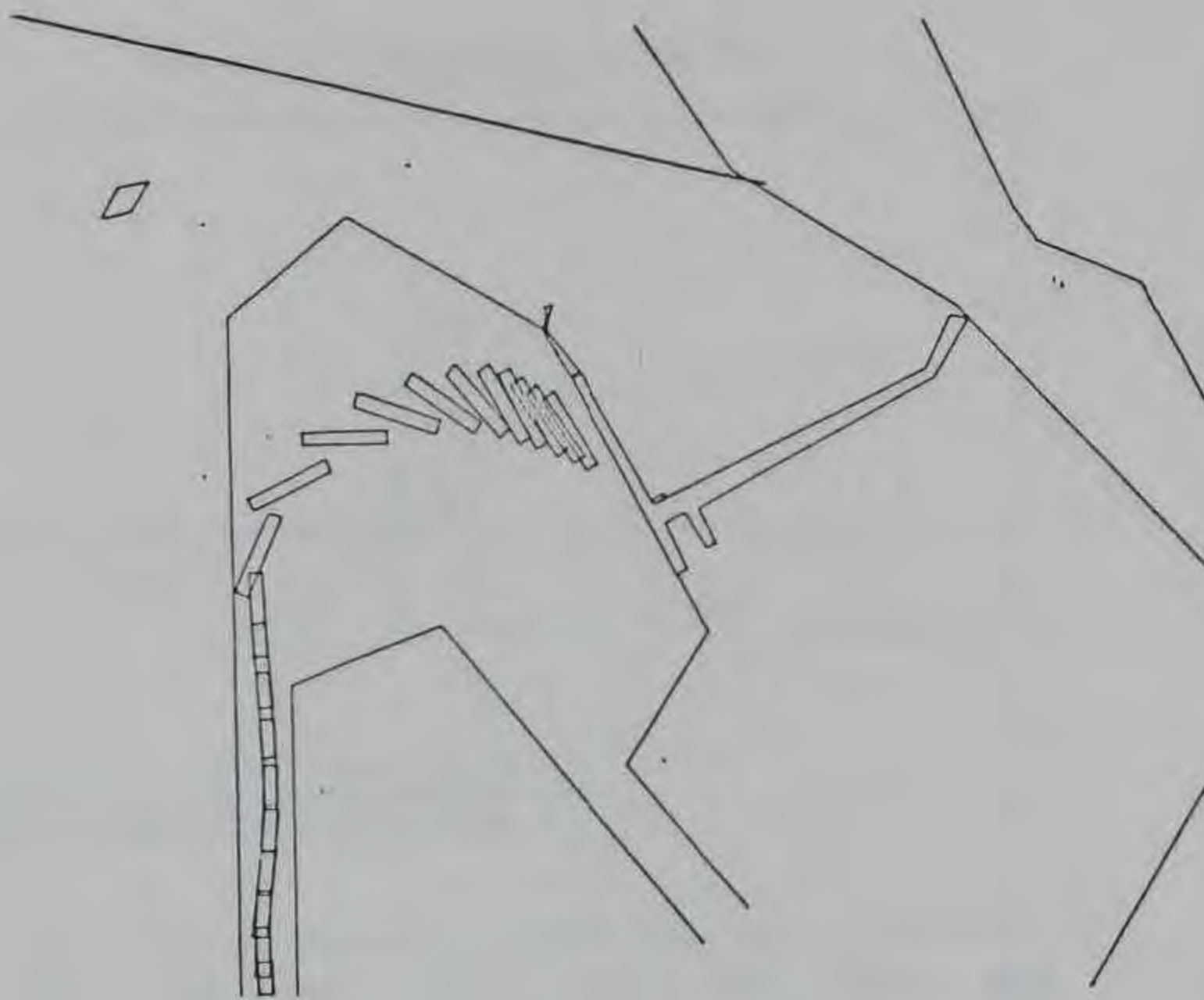

Figure A29. Ship maneuvering, 150K DTFT B3

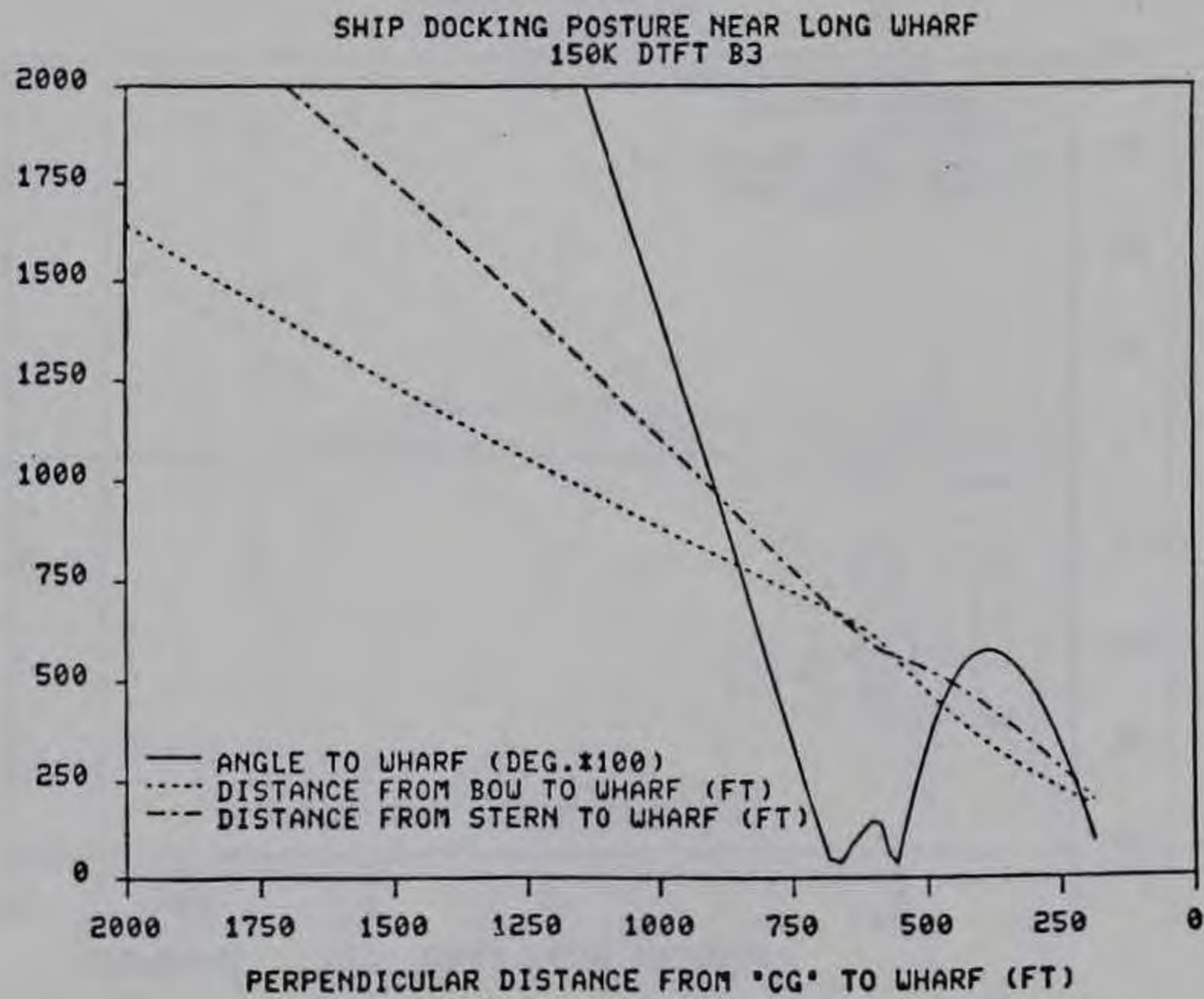
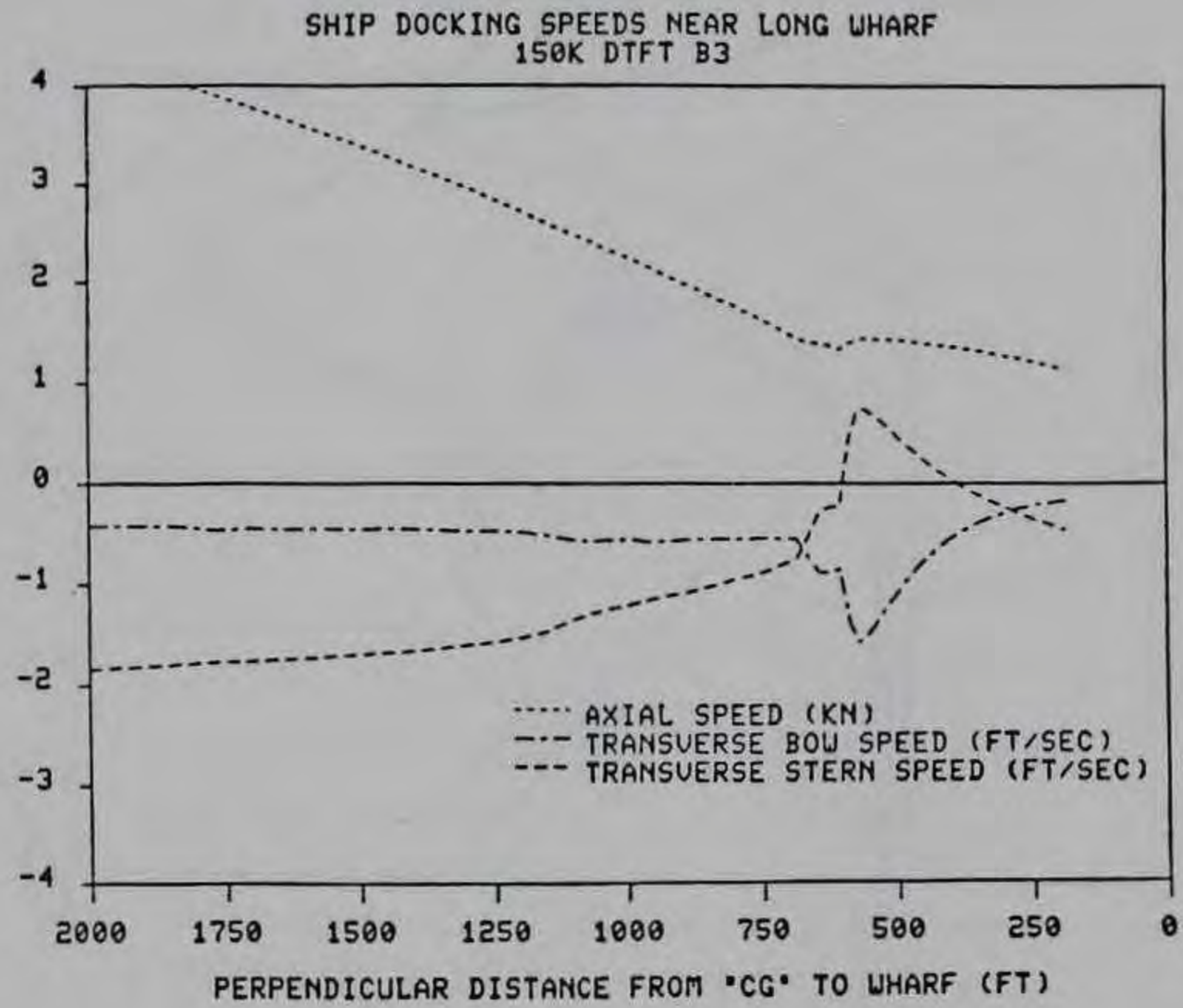

Figure A30. Ship docking speed and posture, 150K DTFT B3

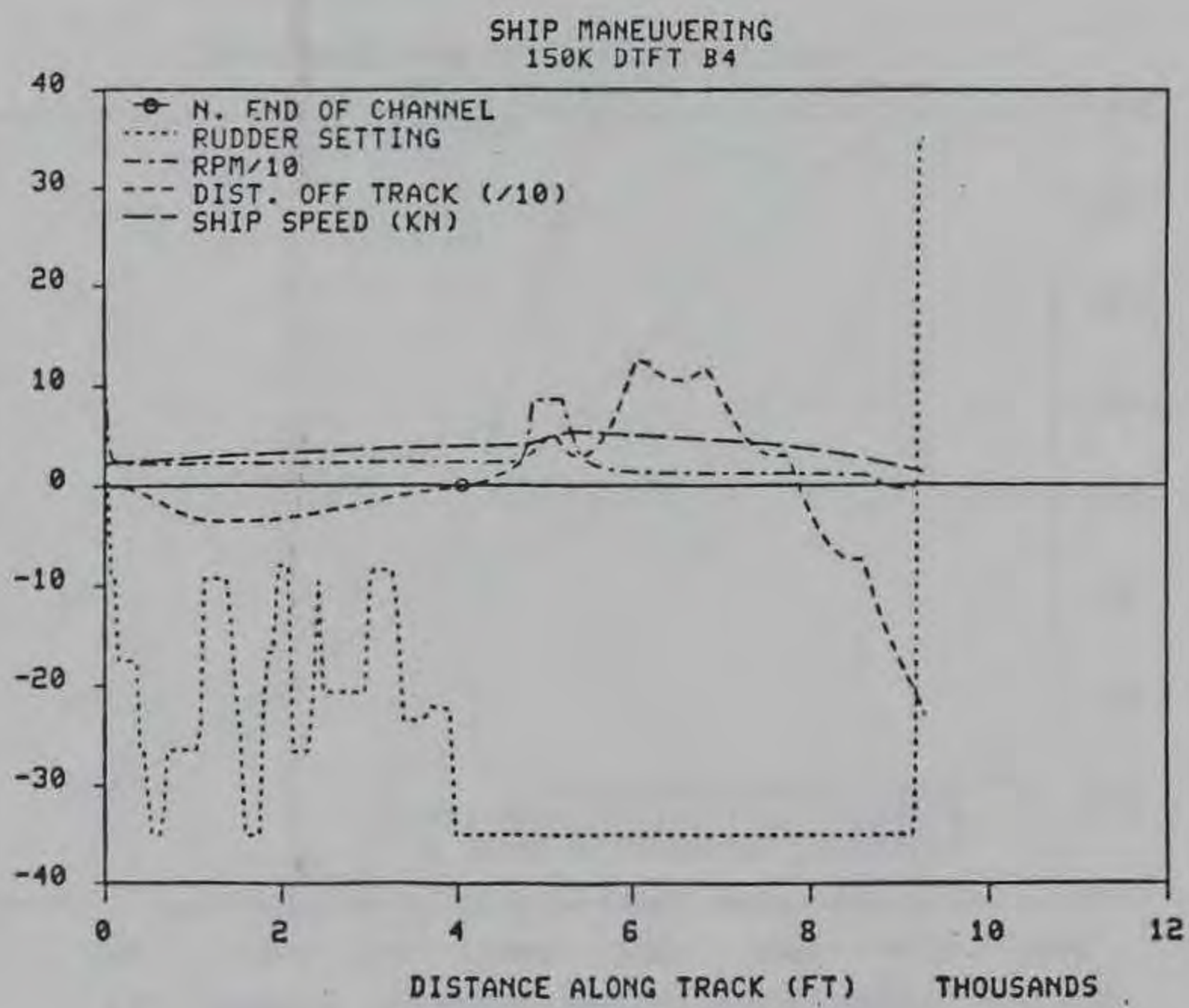
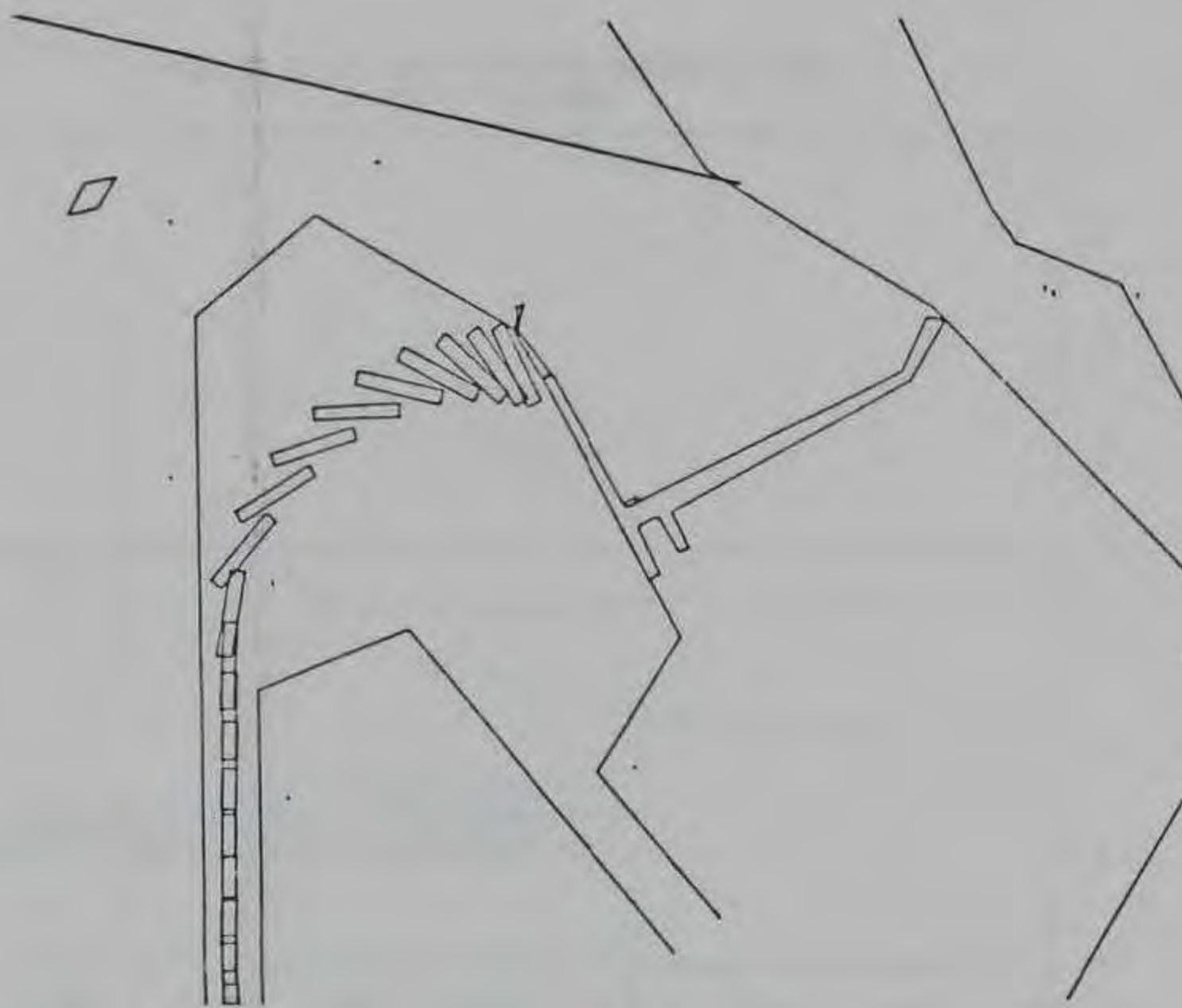

Figure A31. Ship maneuvering, 150K DTFT B4

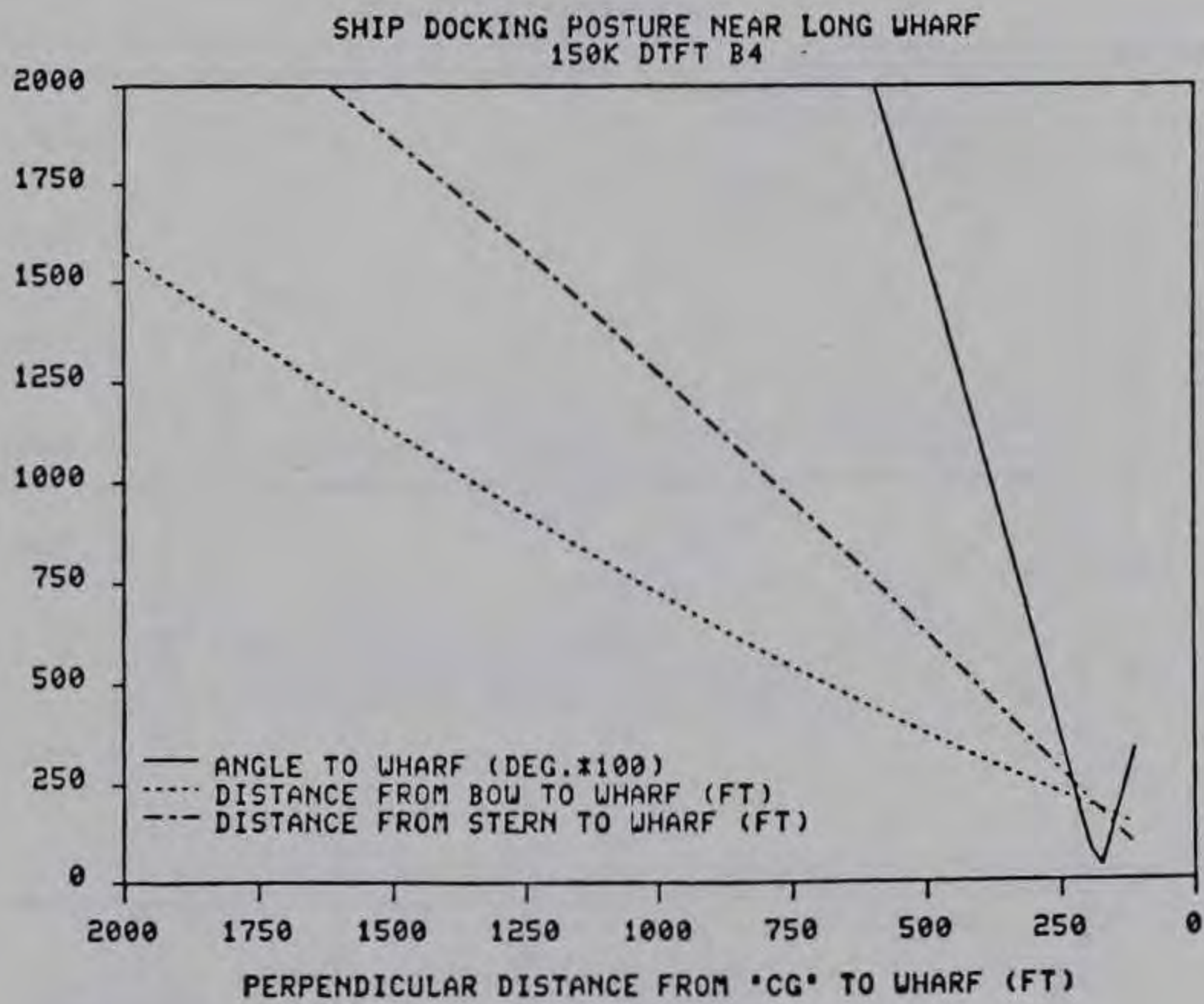
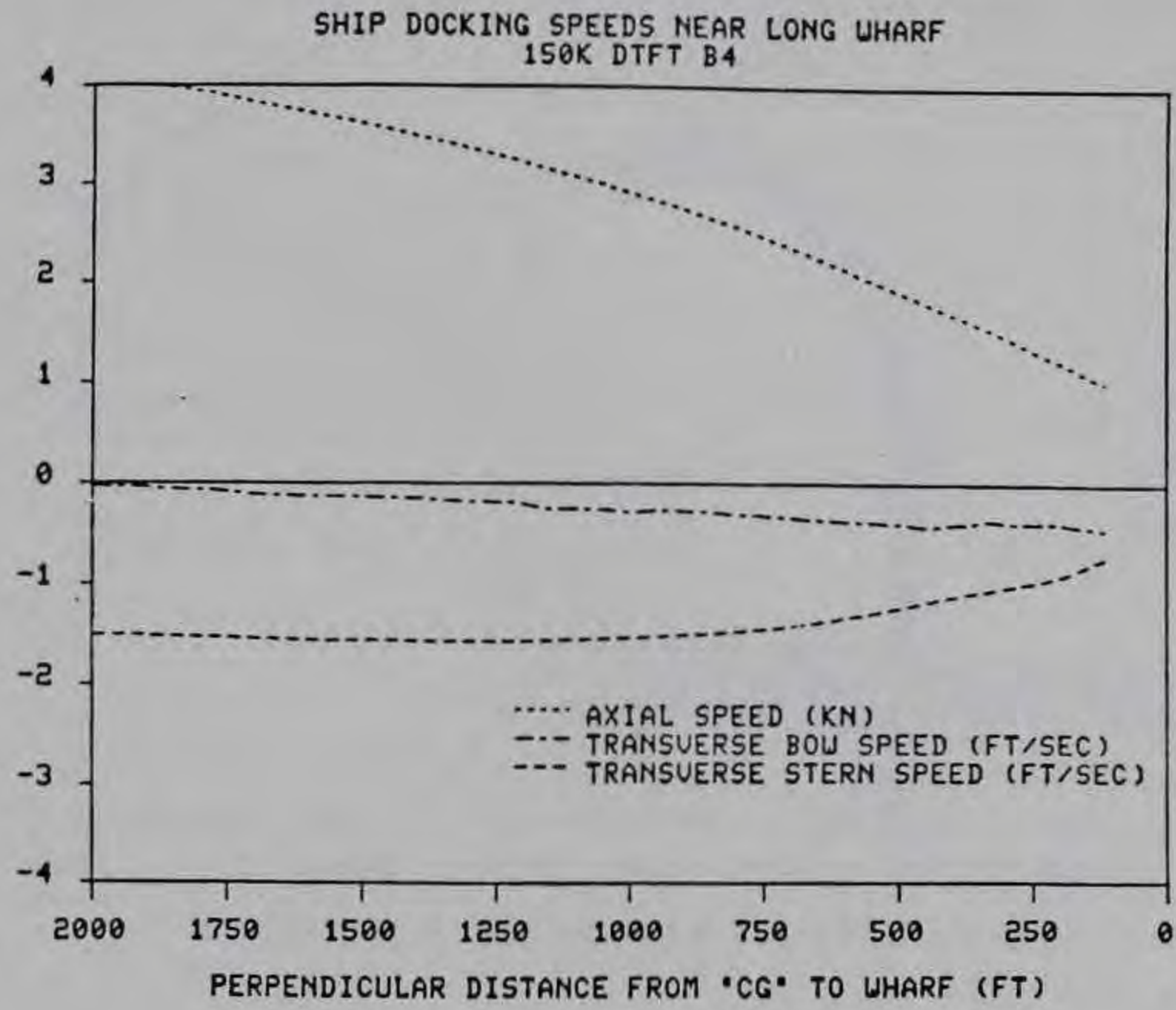

Figure A32. Ship docking speed and posture, 150K DTFT B4

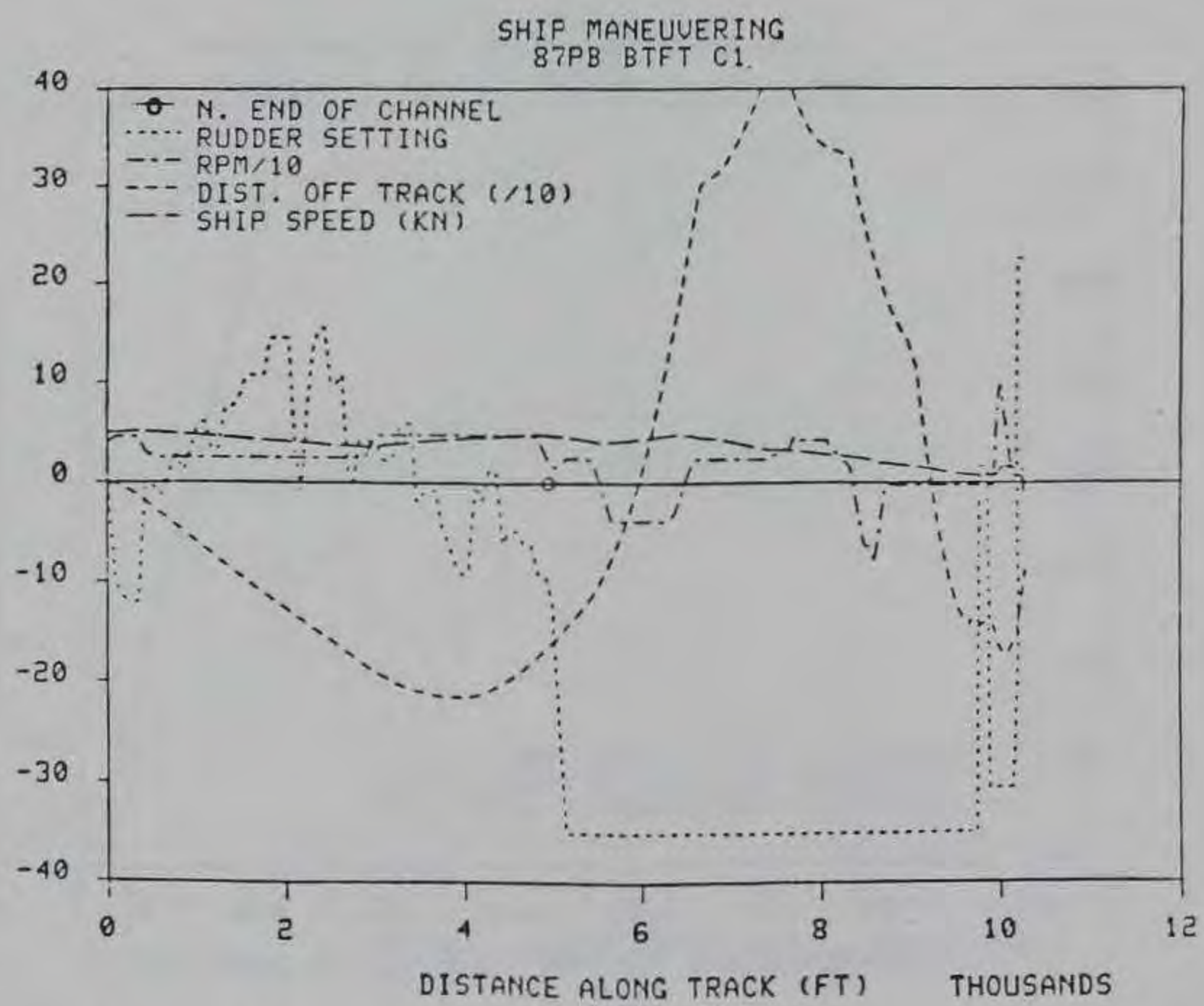
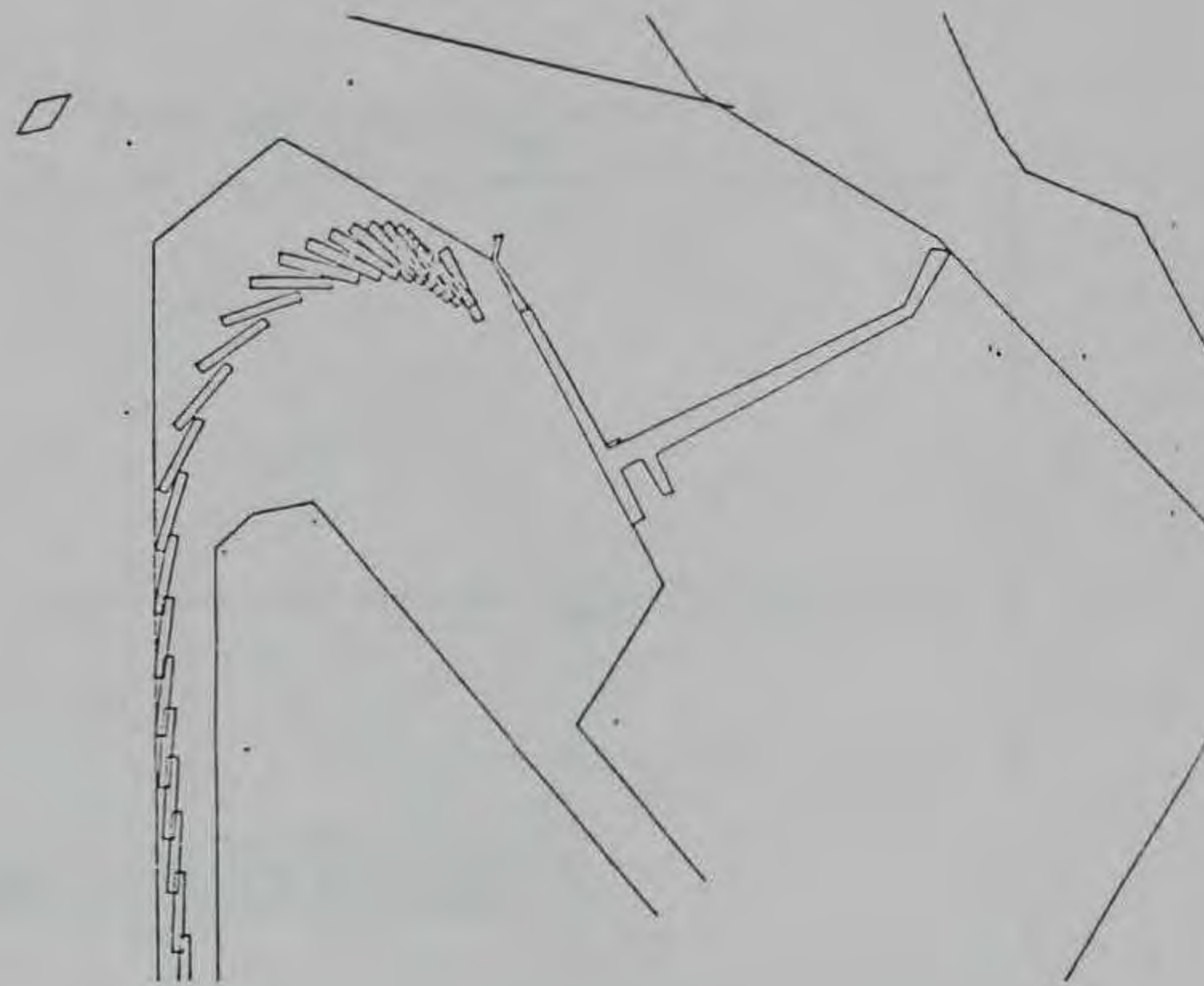

Figure A33. Ship maneuvering, 87PB BTFT C1

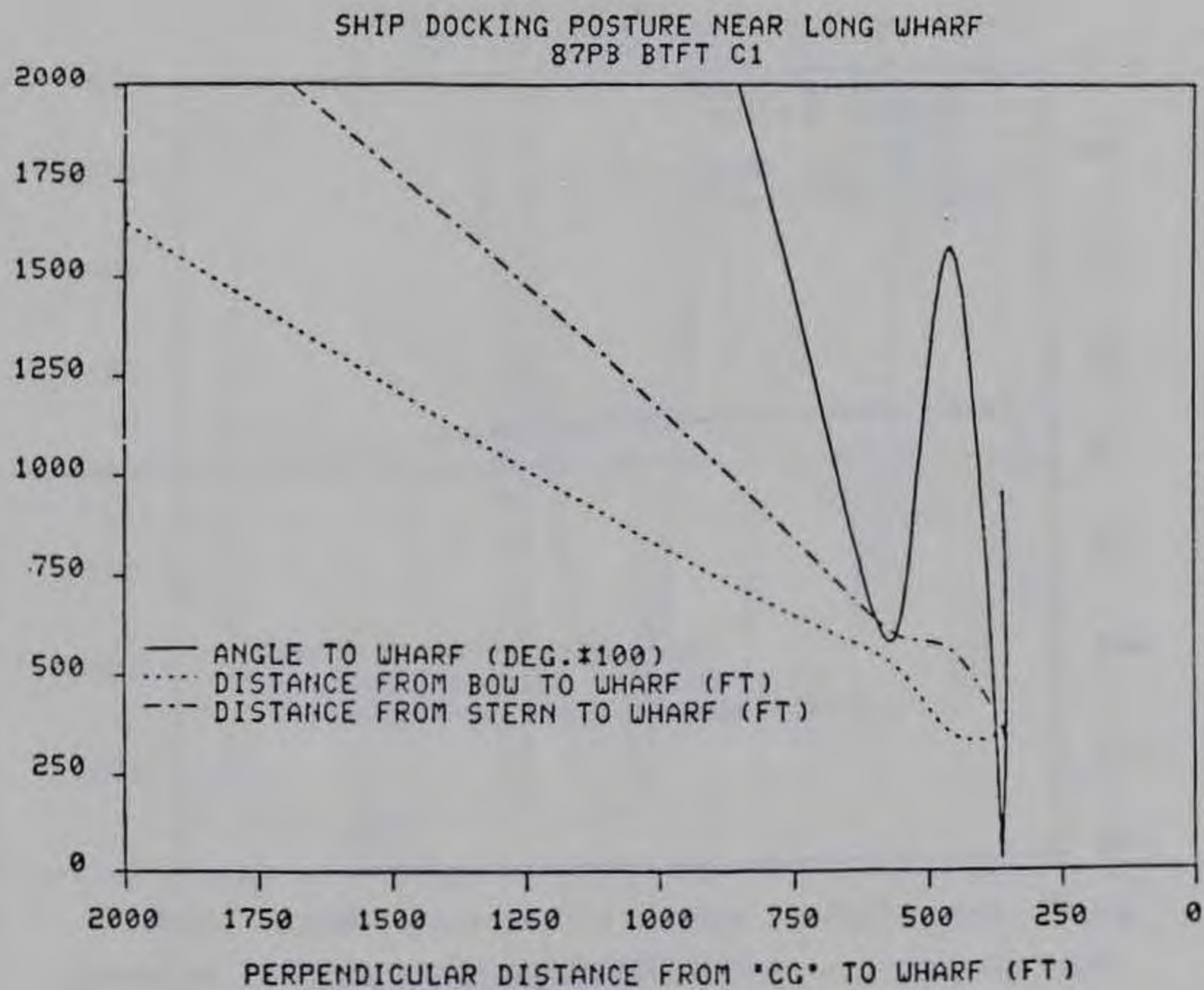
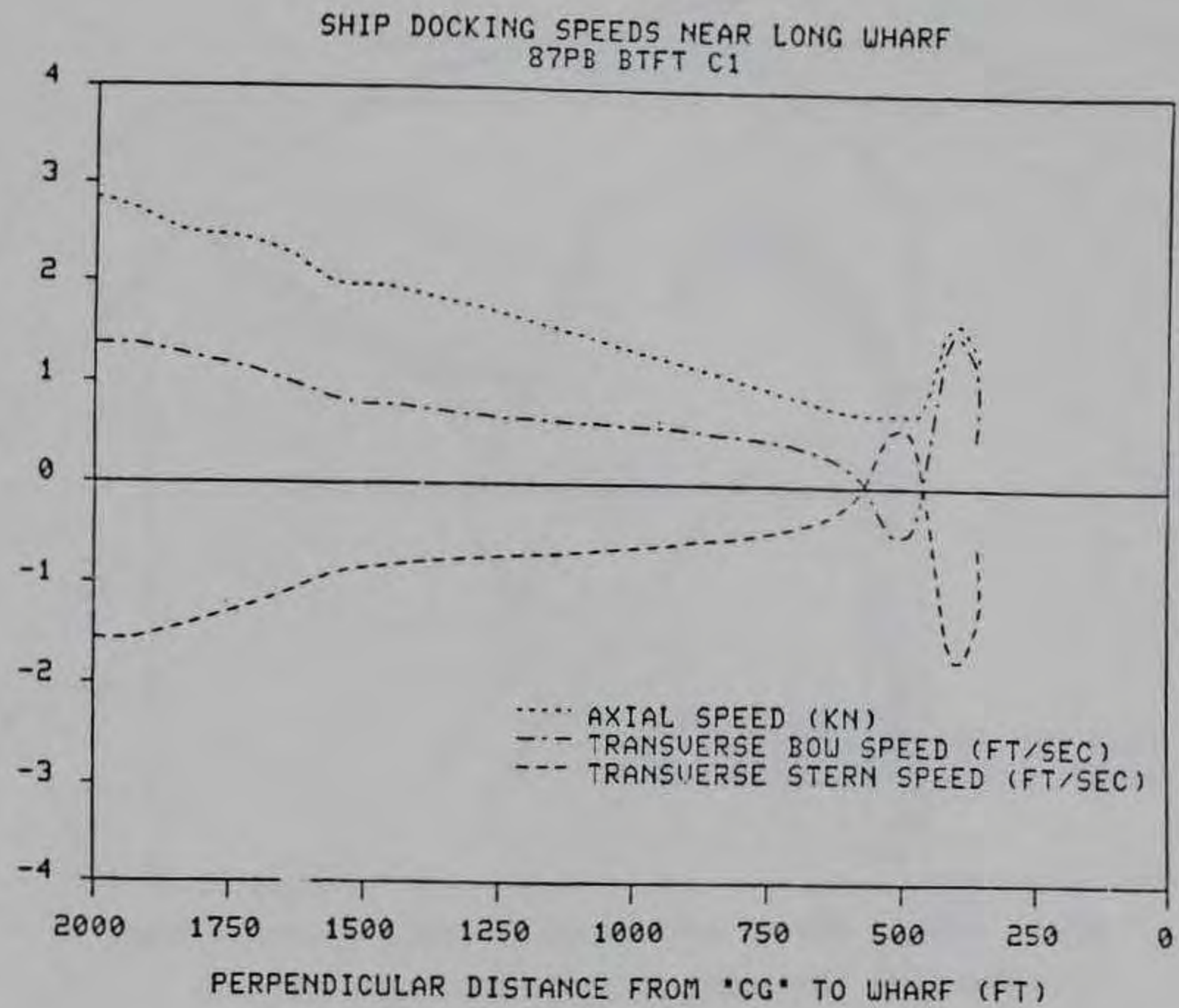

Figure A34. Ship docking speed and posture, 87PB BTFT C1

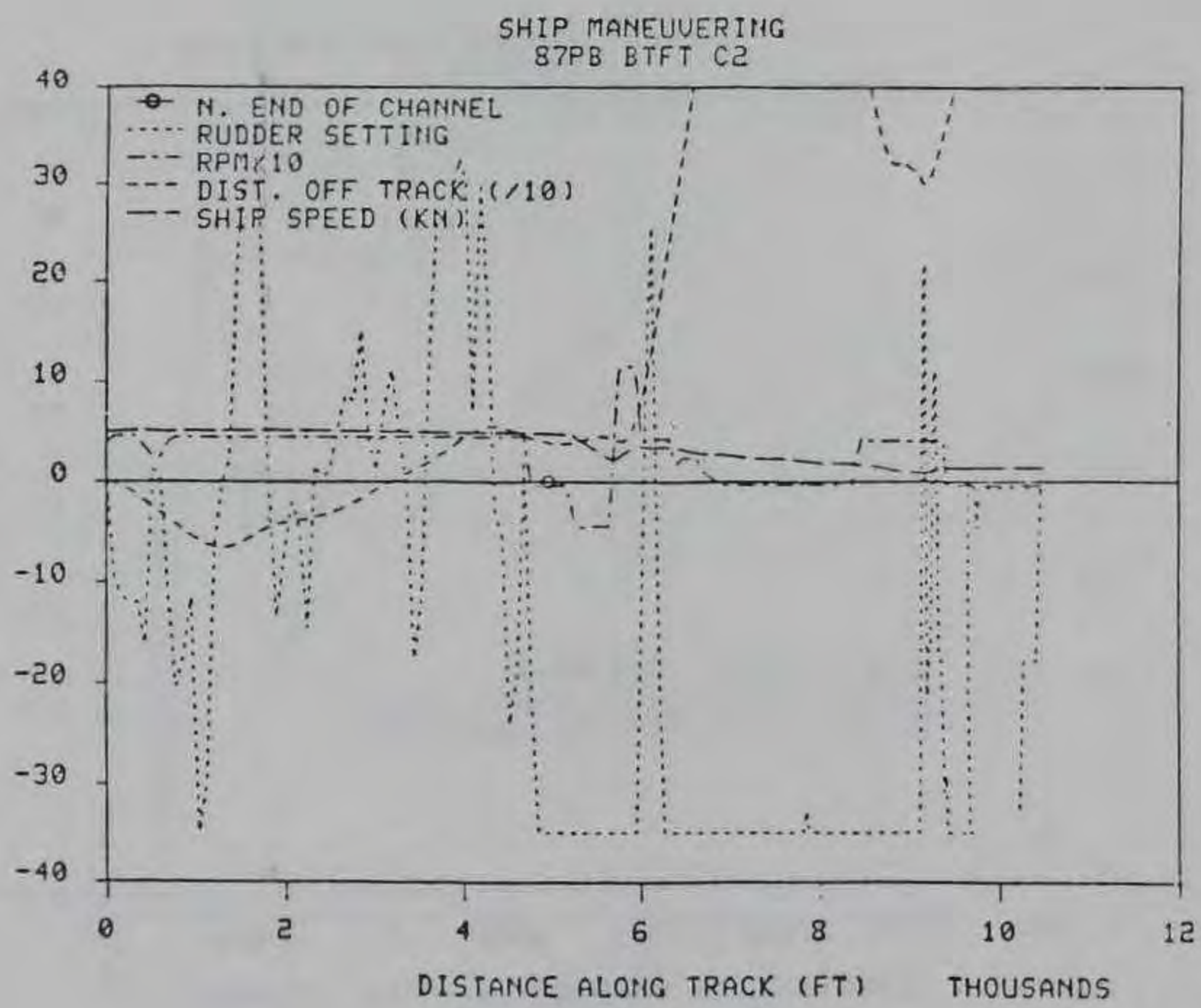
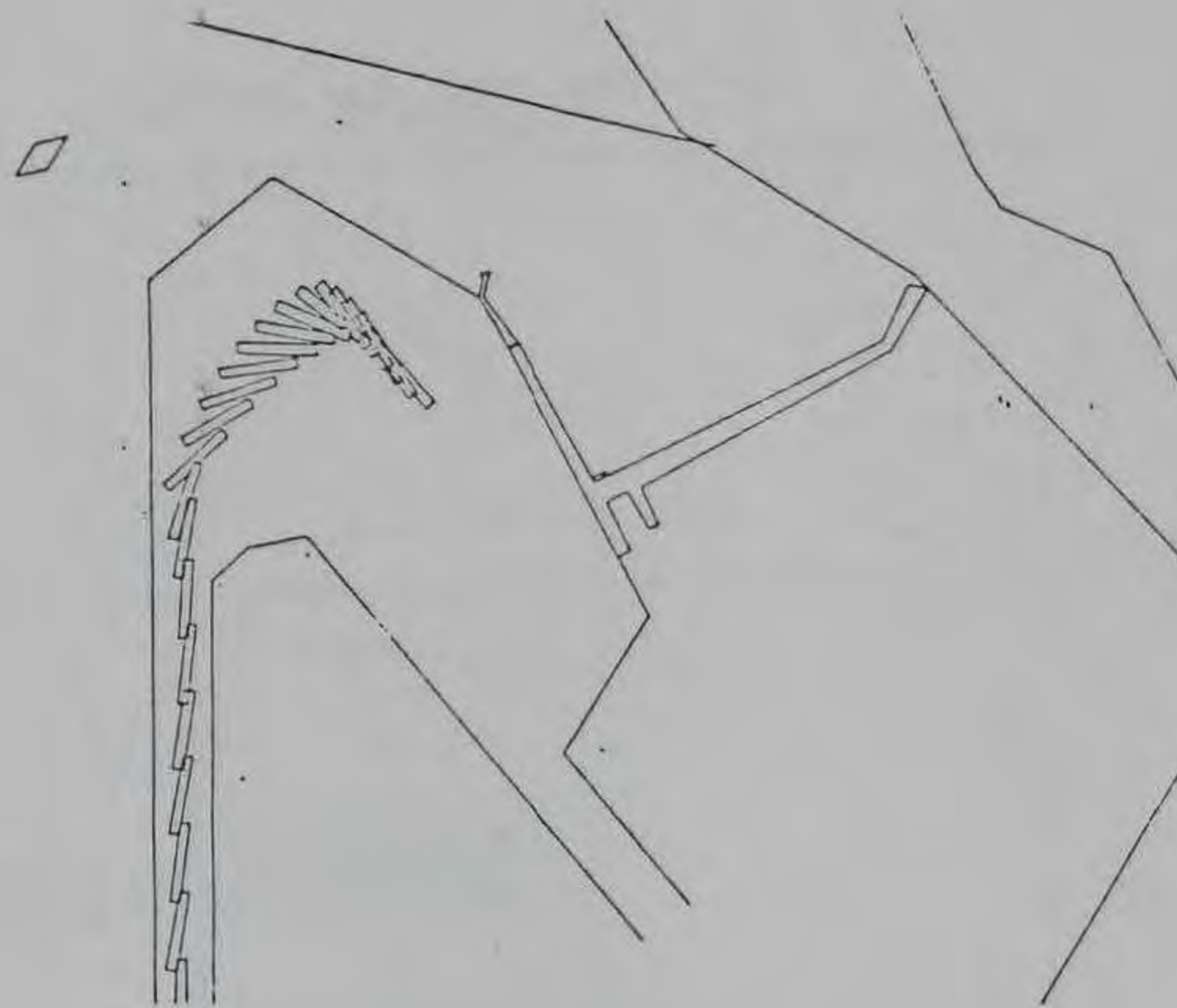

Figure A35. Ship maneuvering, 87PB BTFT C2

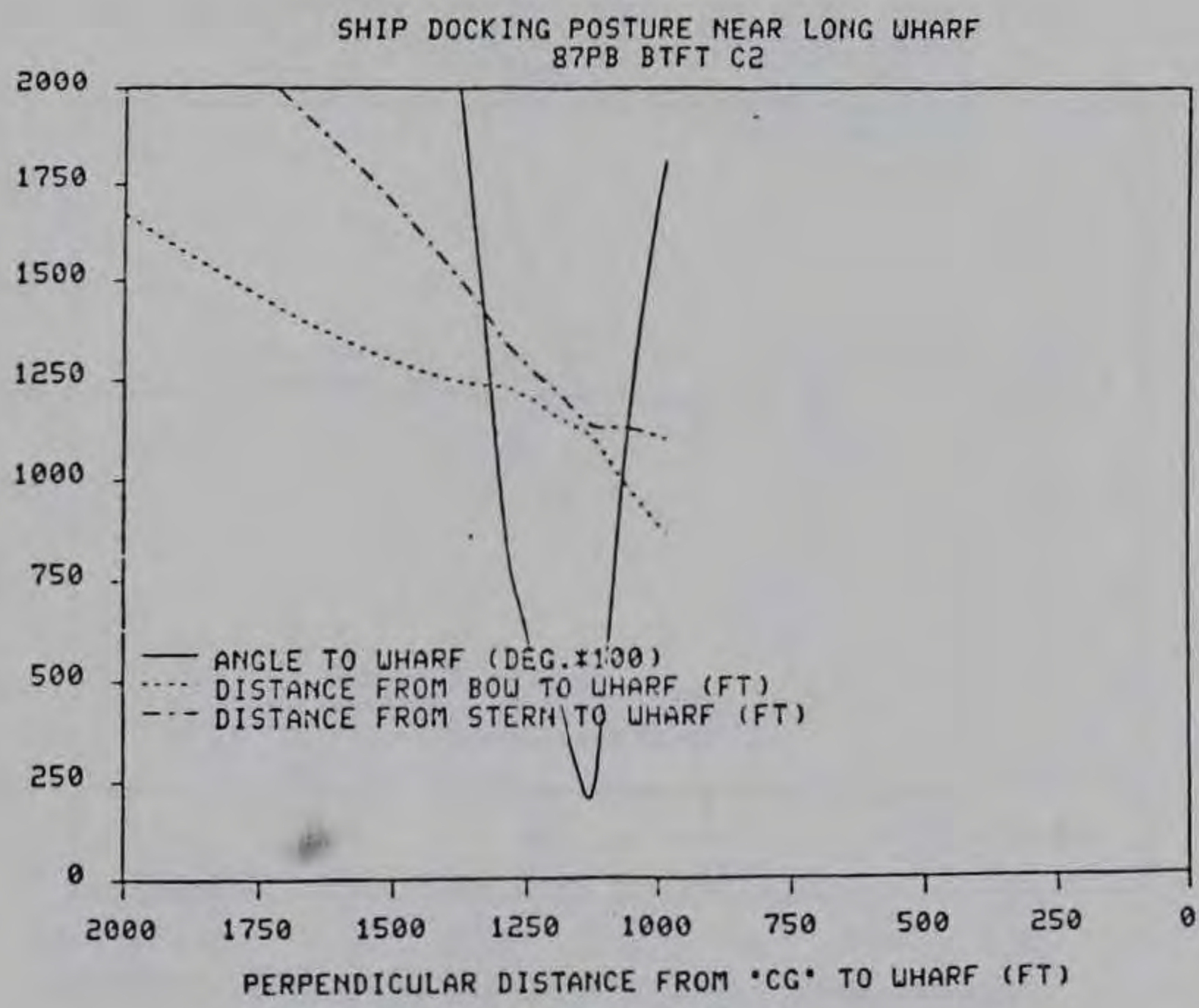
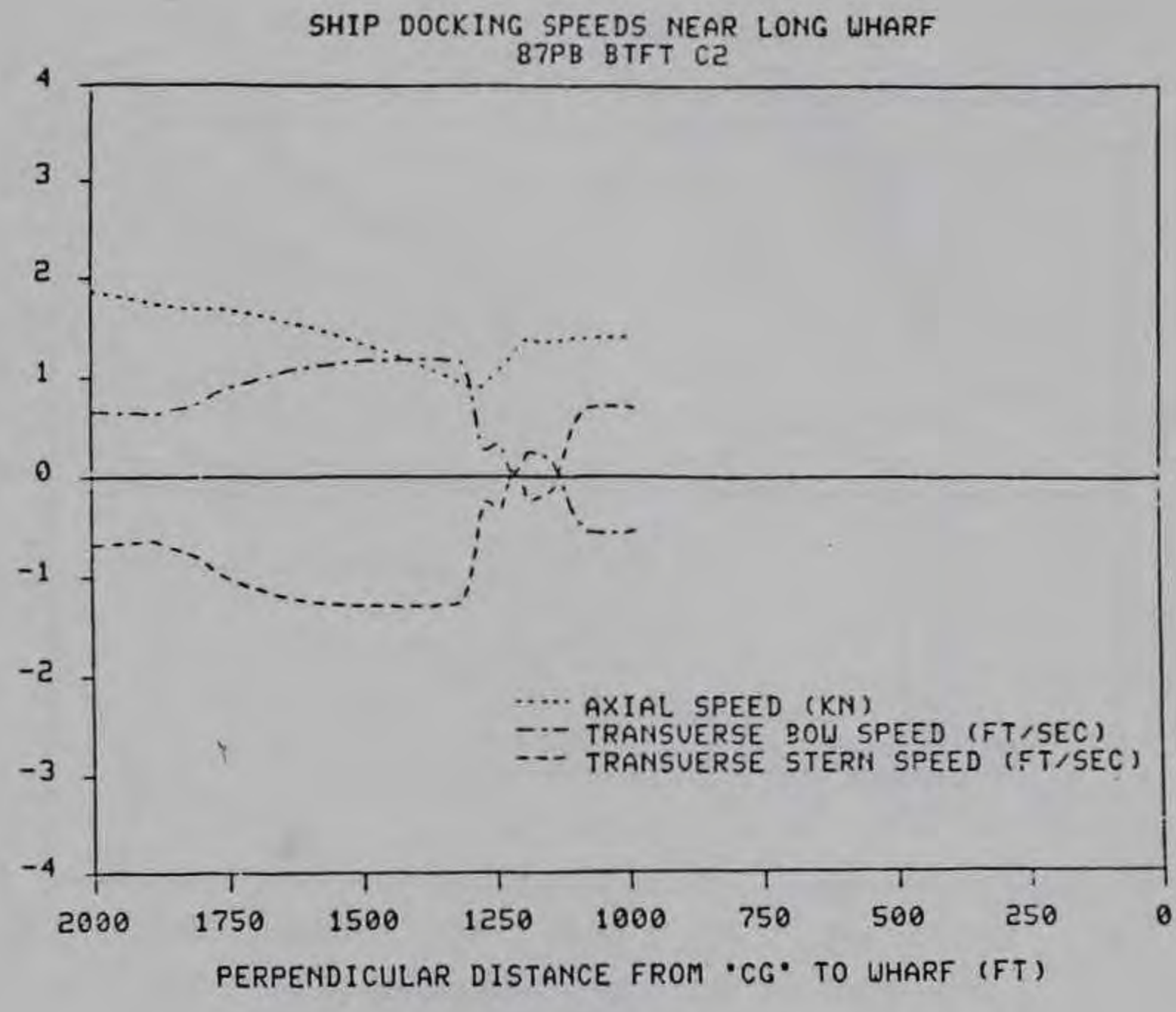

Figure A36. Ship docking speed and posture, 87PB BTFT C2

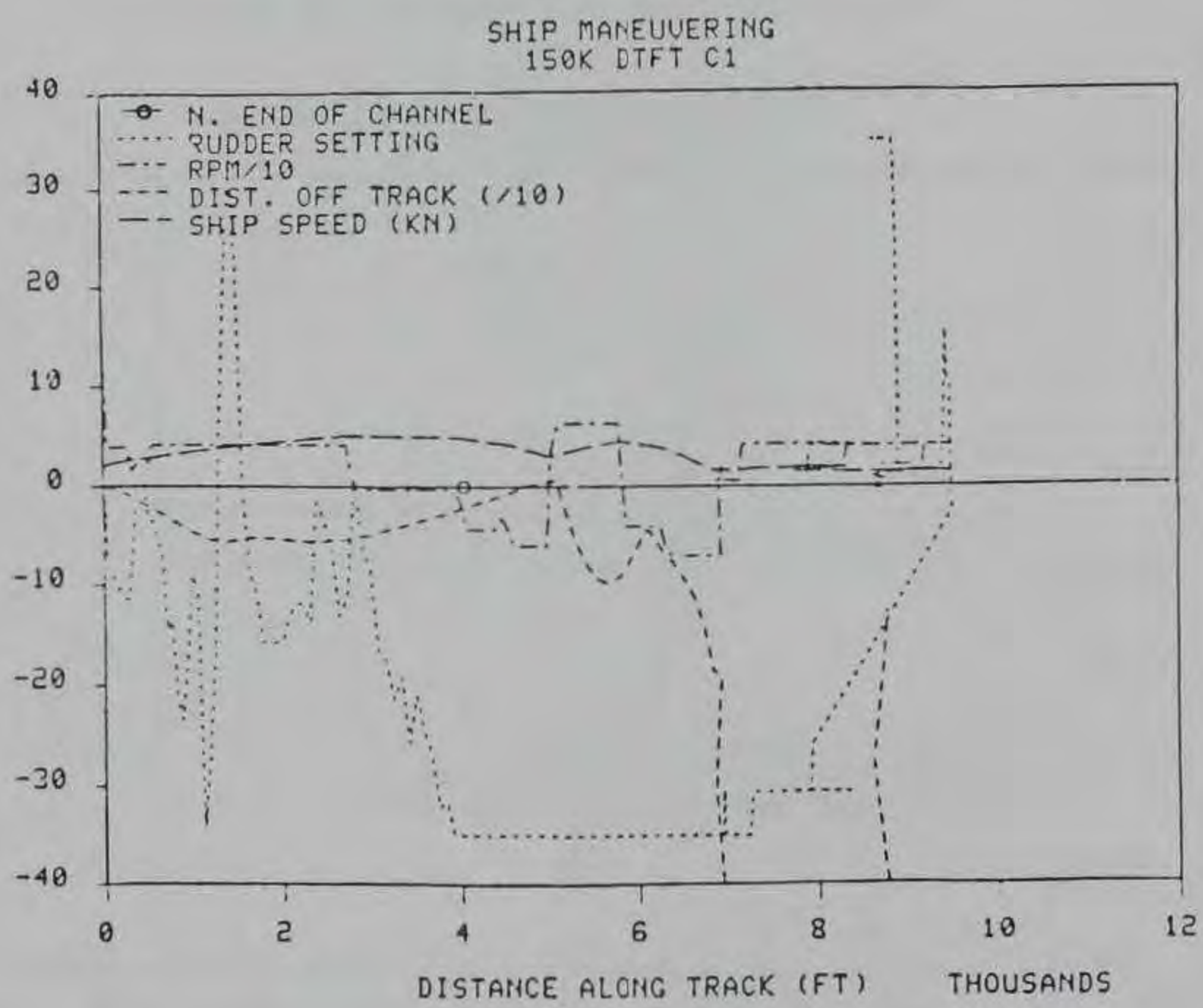
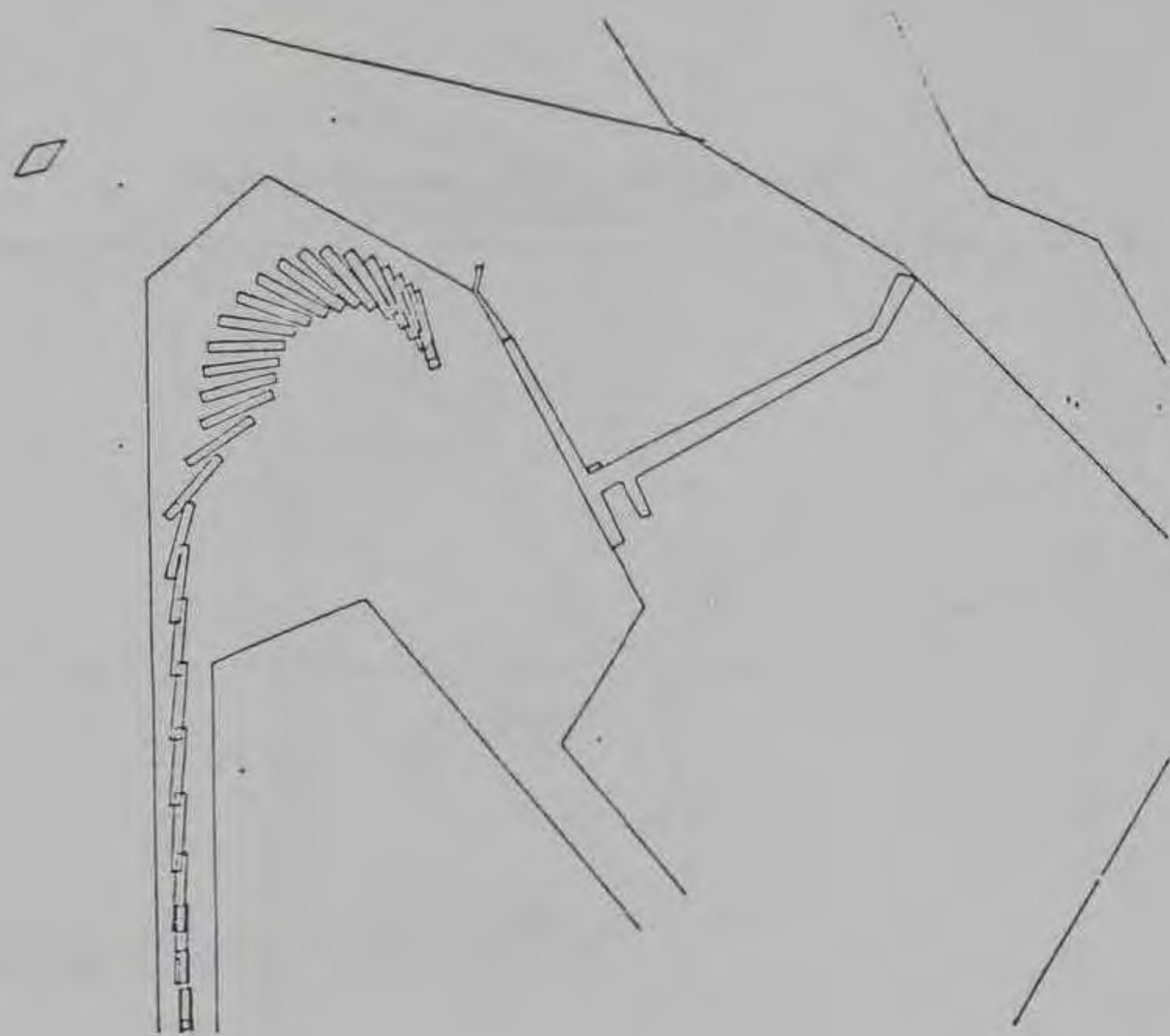

Figure A37. Ship maneuvering, 150K DTFT C1

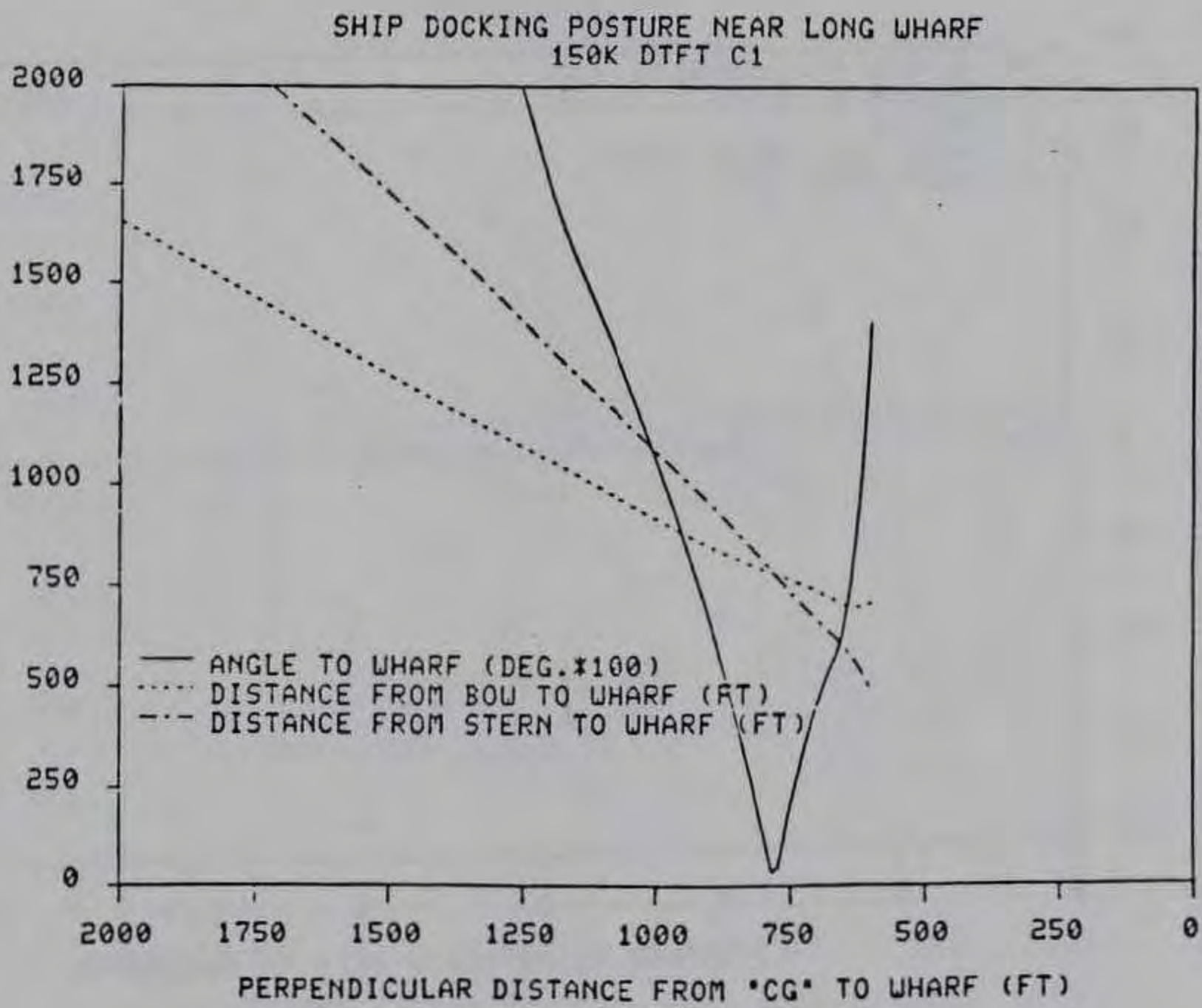
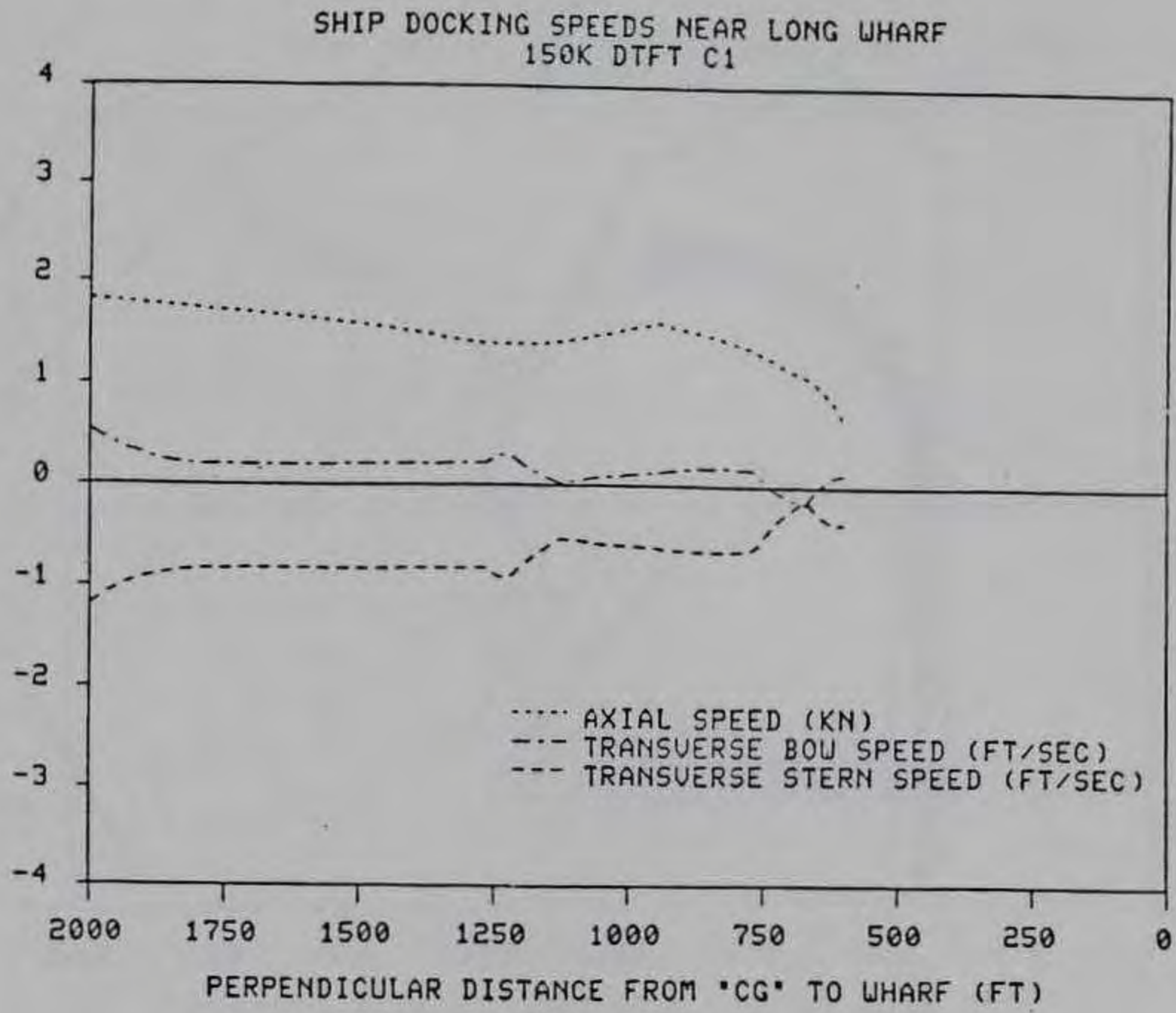

Figure A38. Ship docking speed and posture, 150K DTFT C1

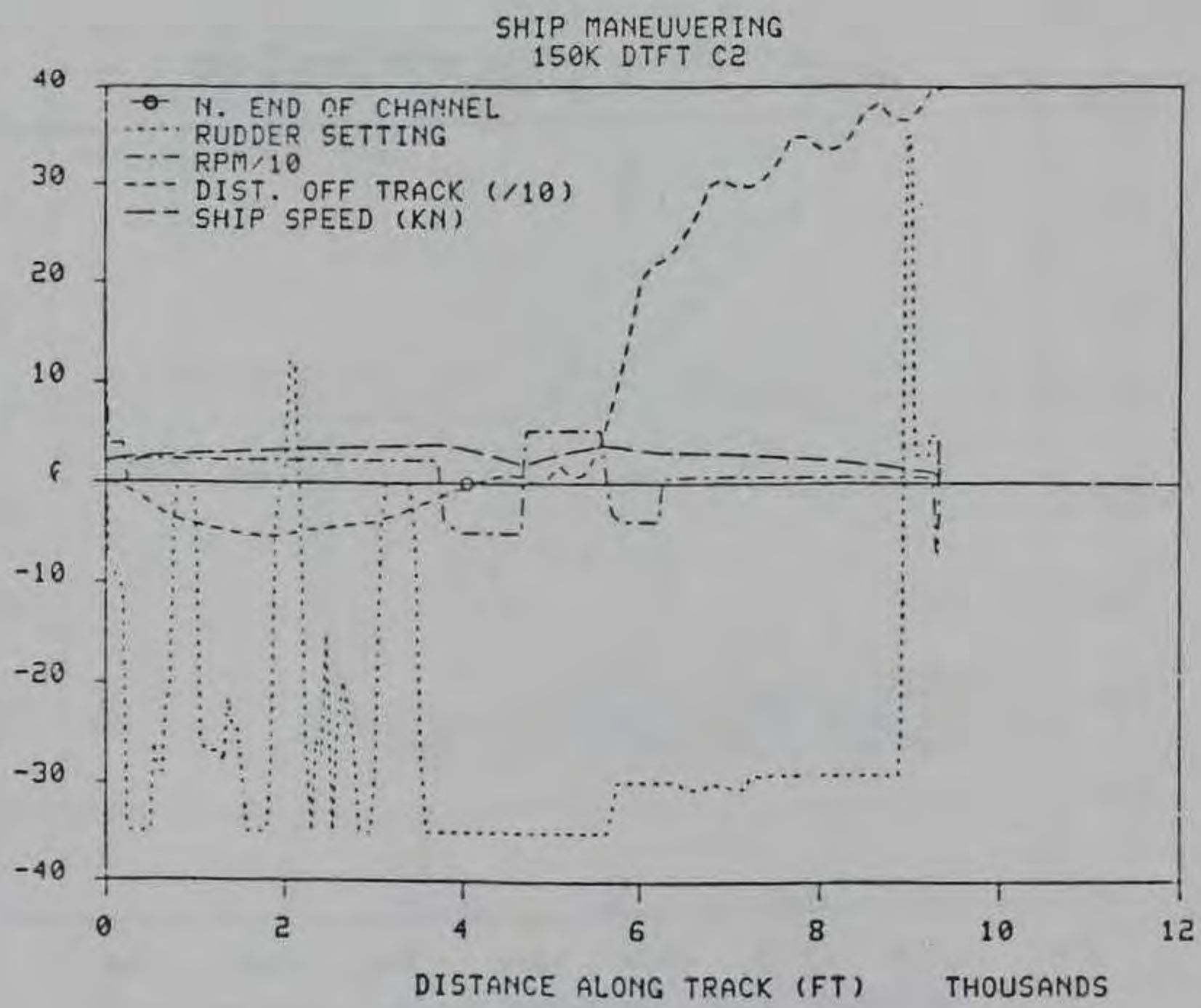
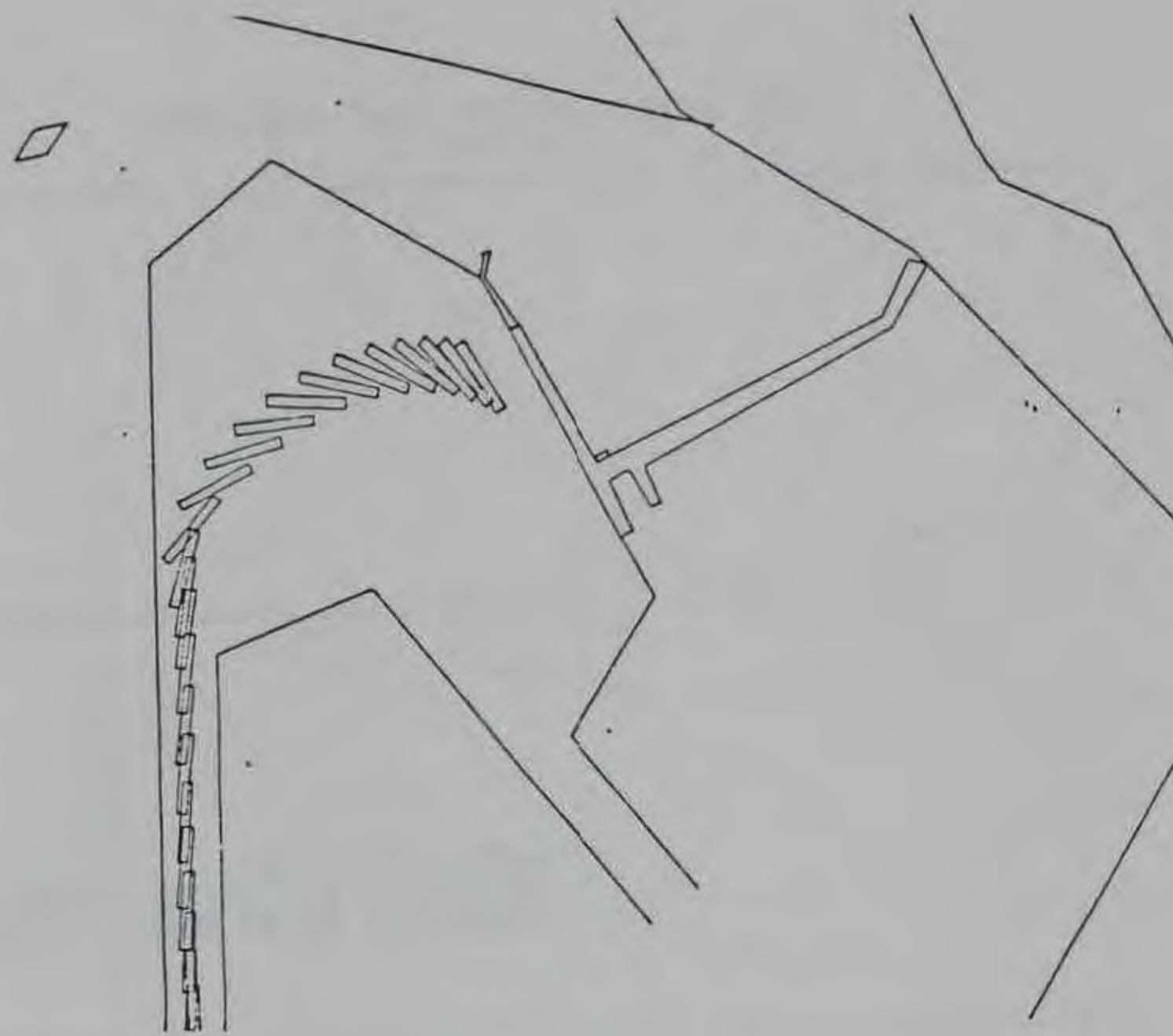

Figure A39. Ship maneuvering, 150K DTFT C2

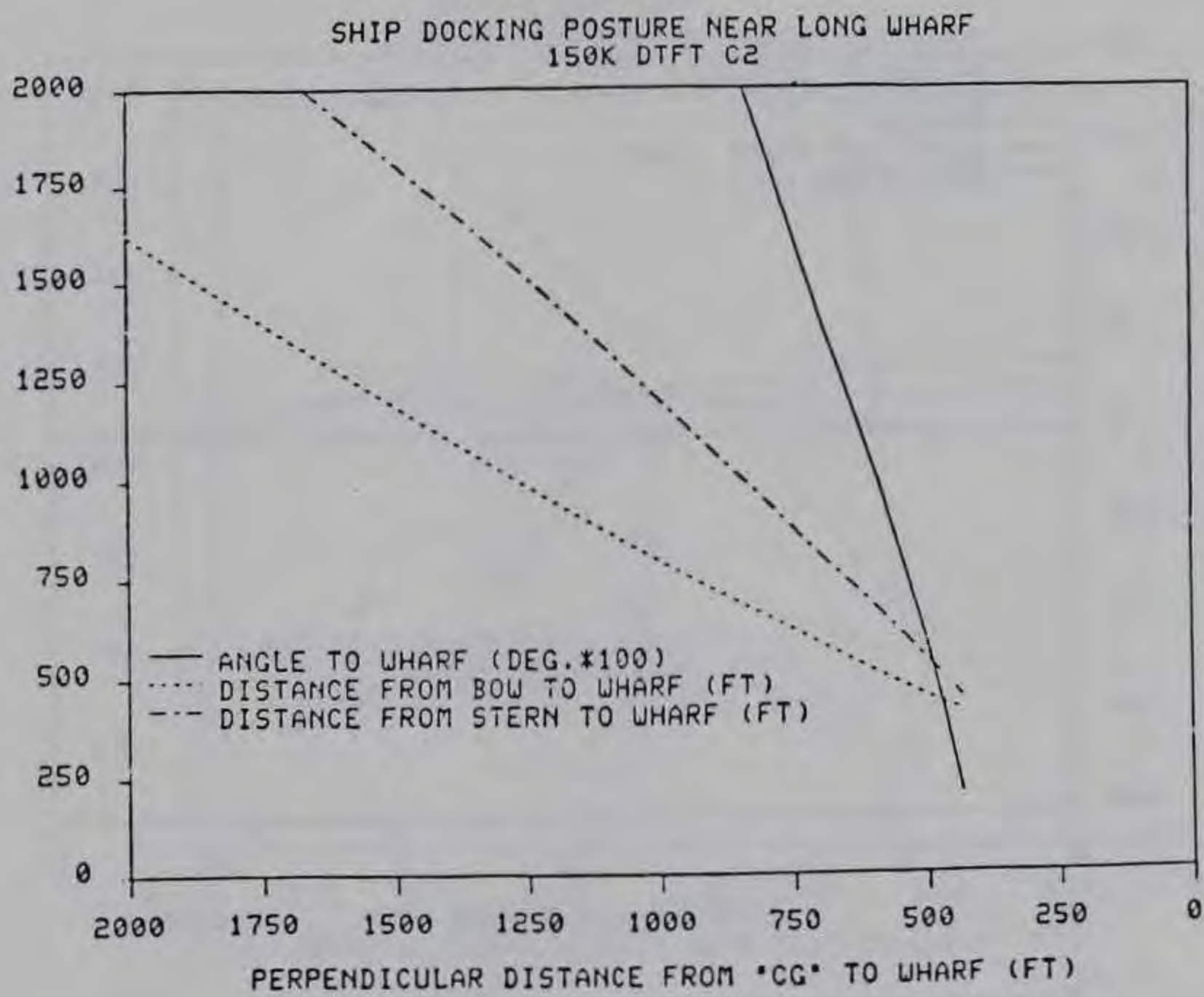
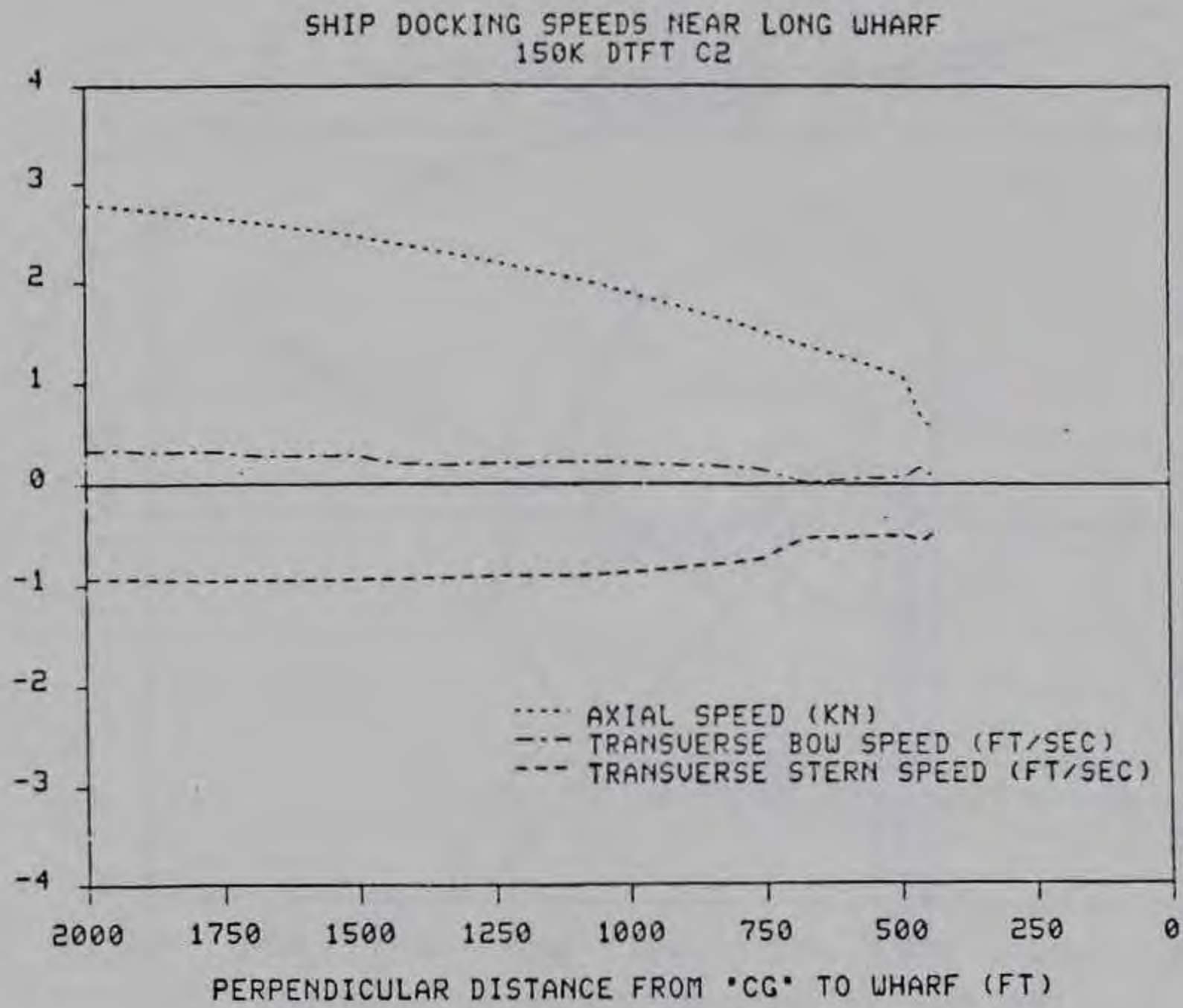

Figure A40. Ship docking speed and posture, 150K DTFT C2

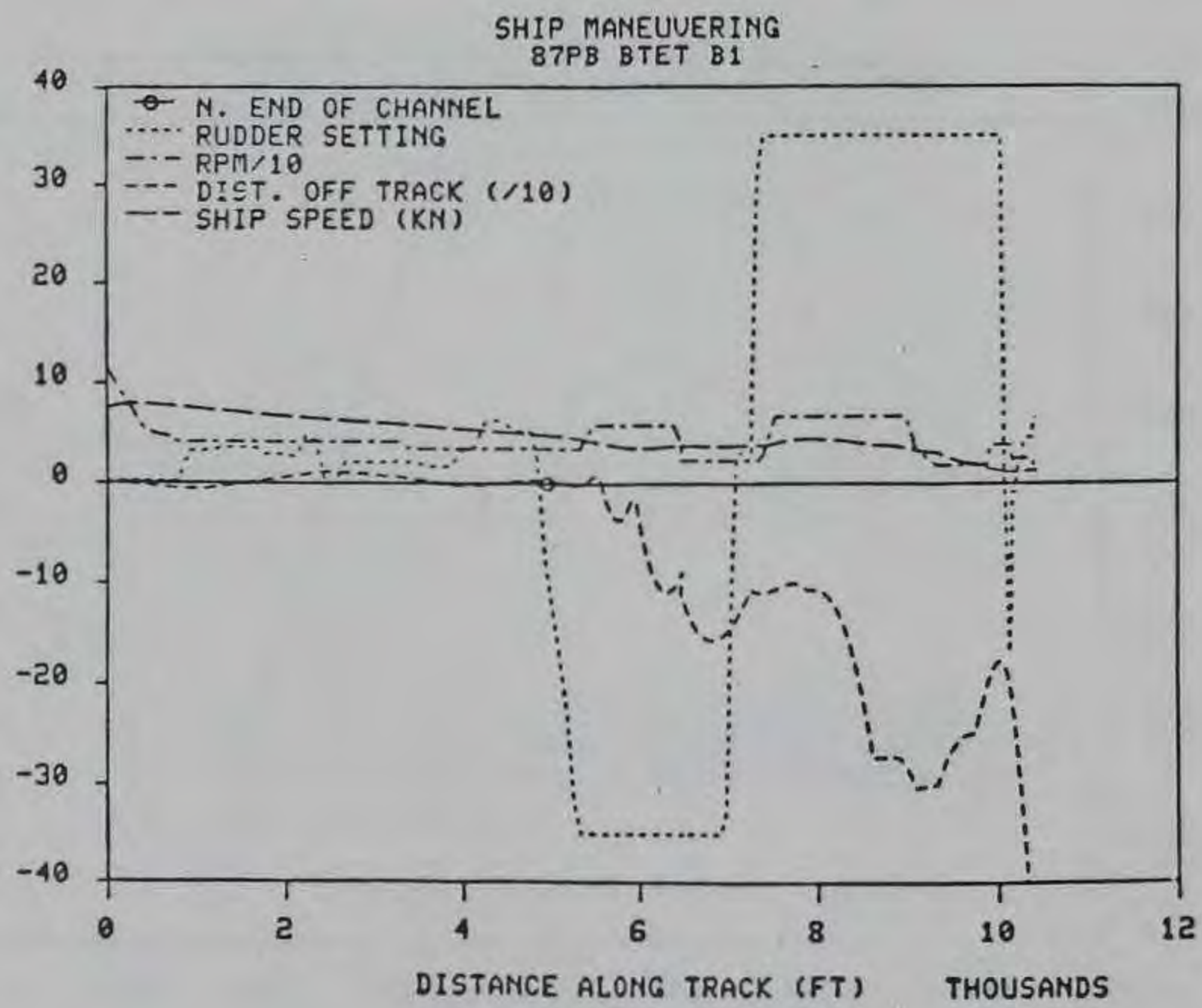

Figure A41. Ship maneuvering, 87PB BTET B1

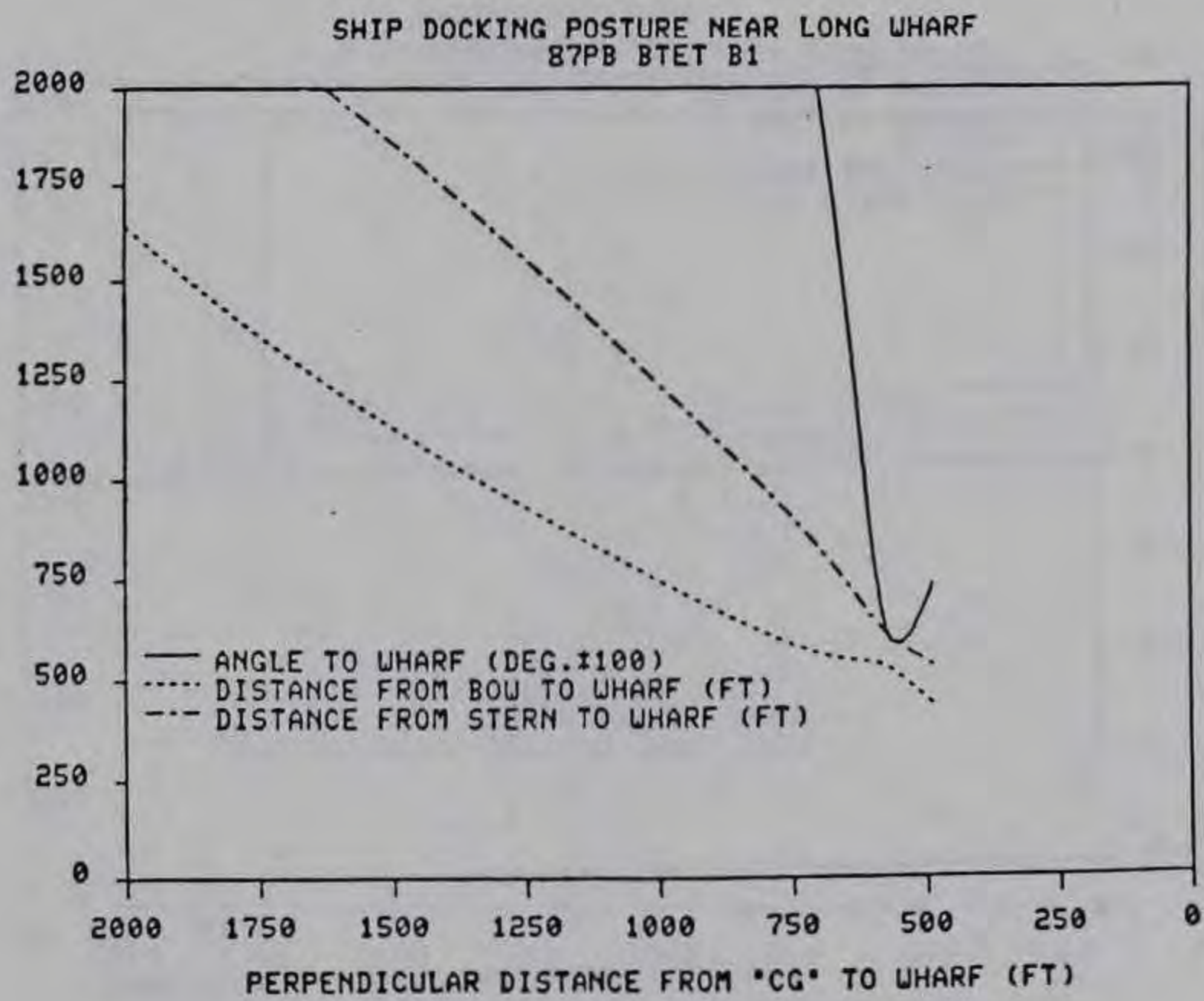
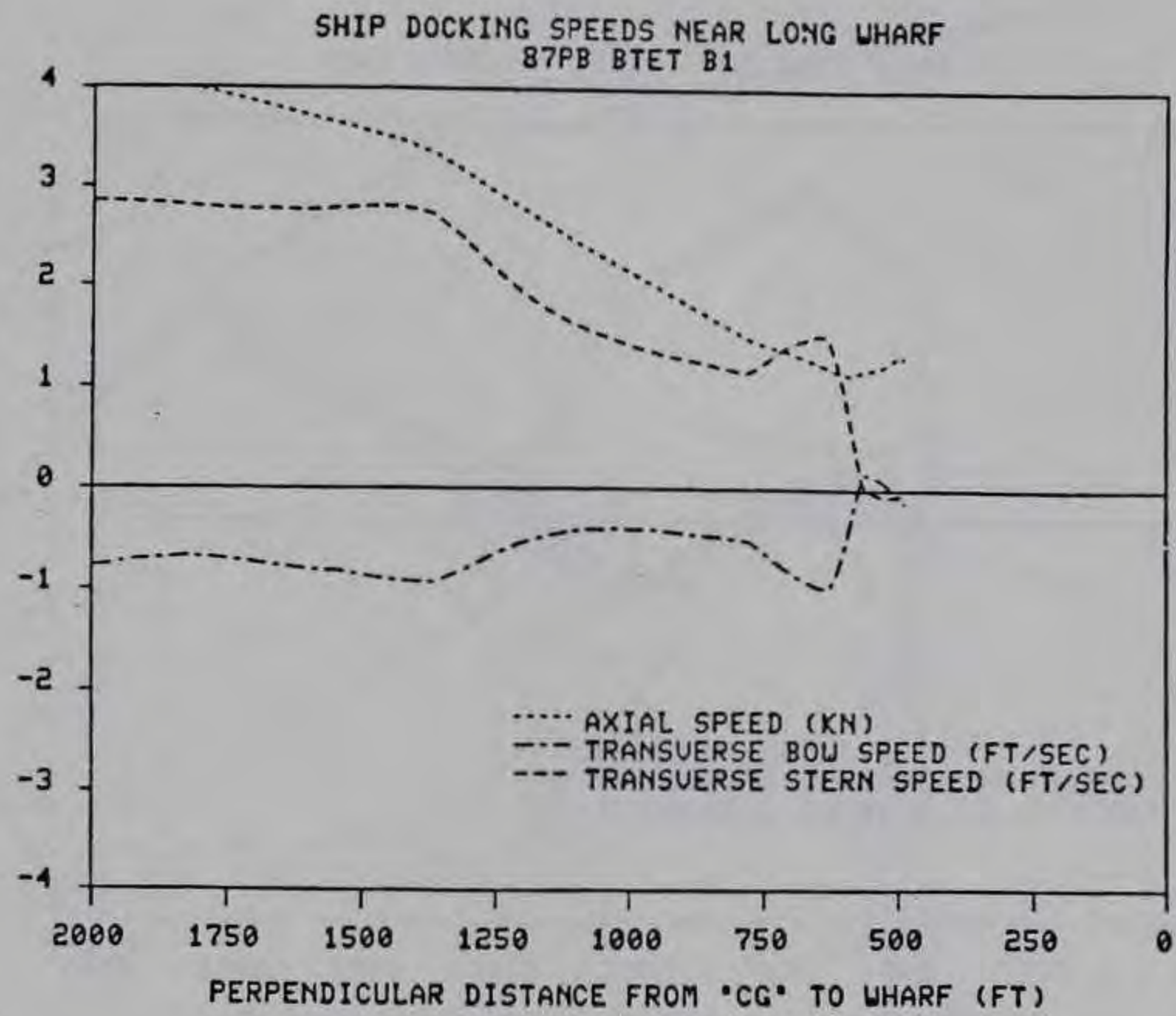

Figure A42. Ship docking speed and posture, 87PB BTET B1

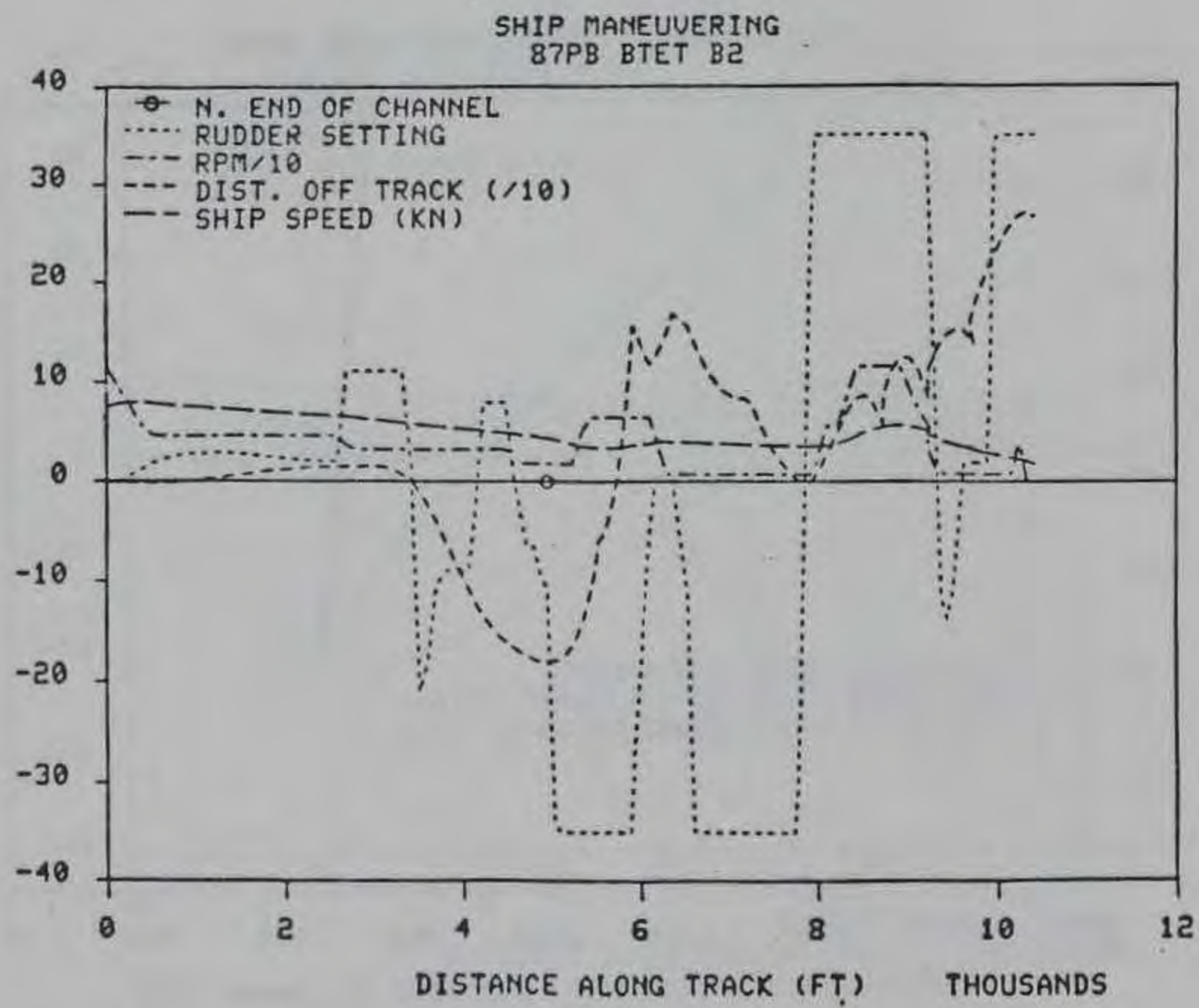
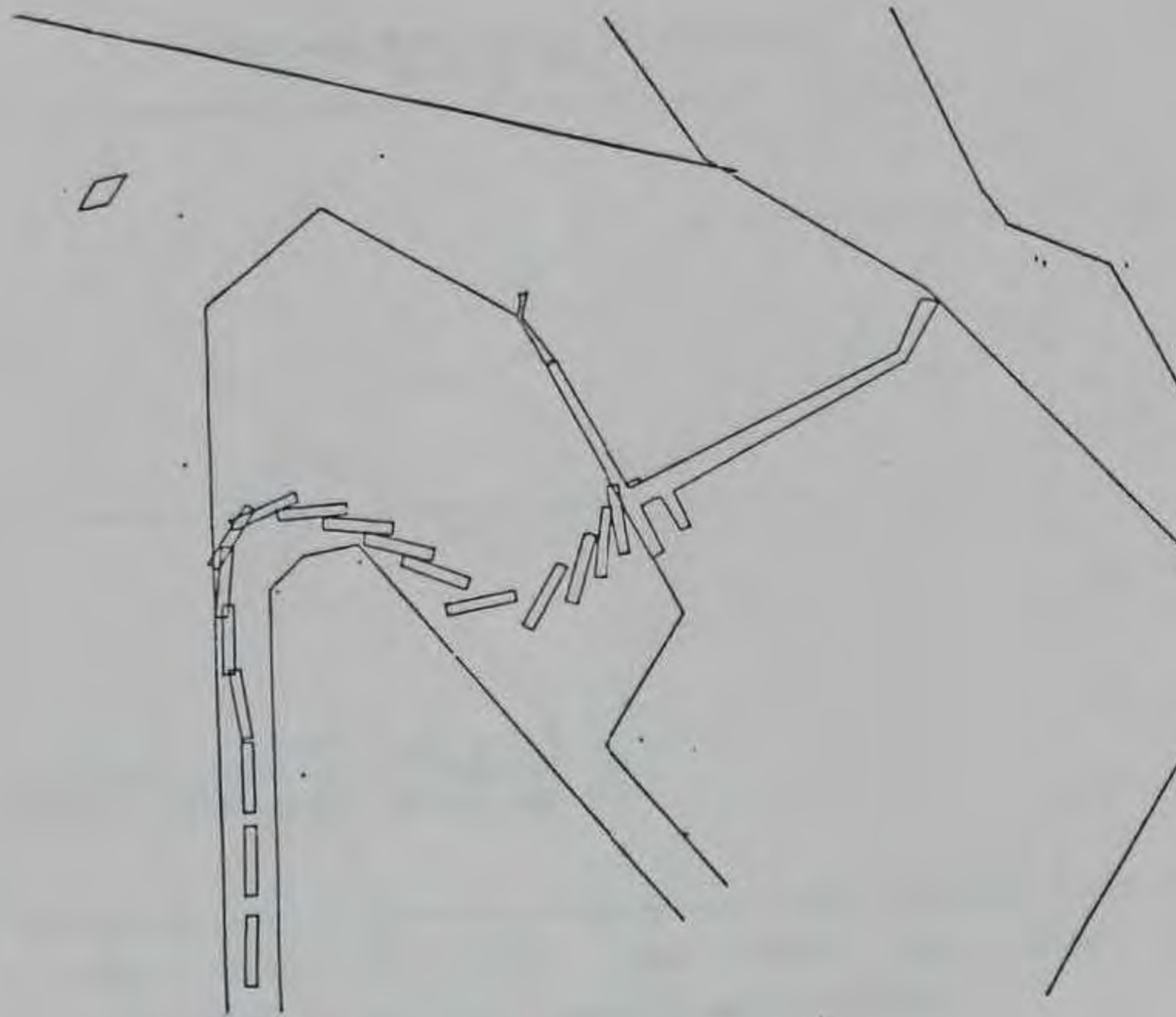

Figure A43. Ship maneuvering, 87PB BTET B2

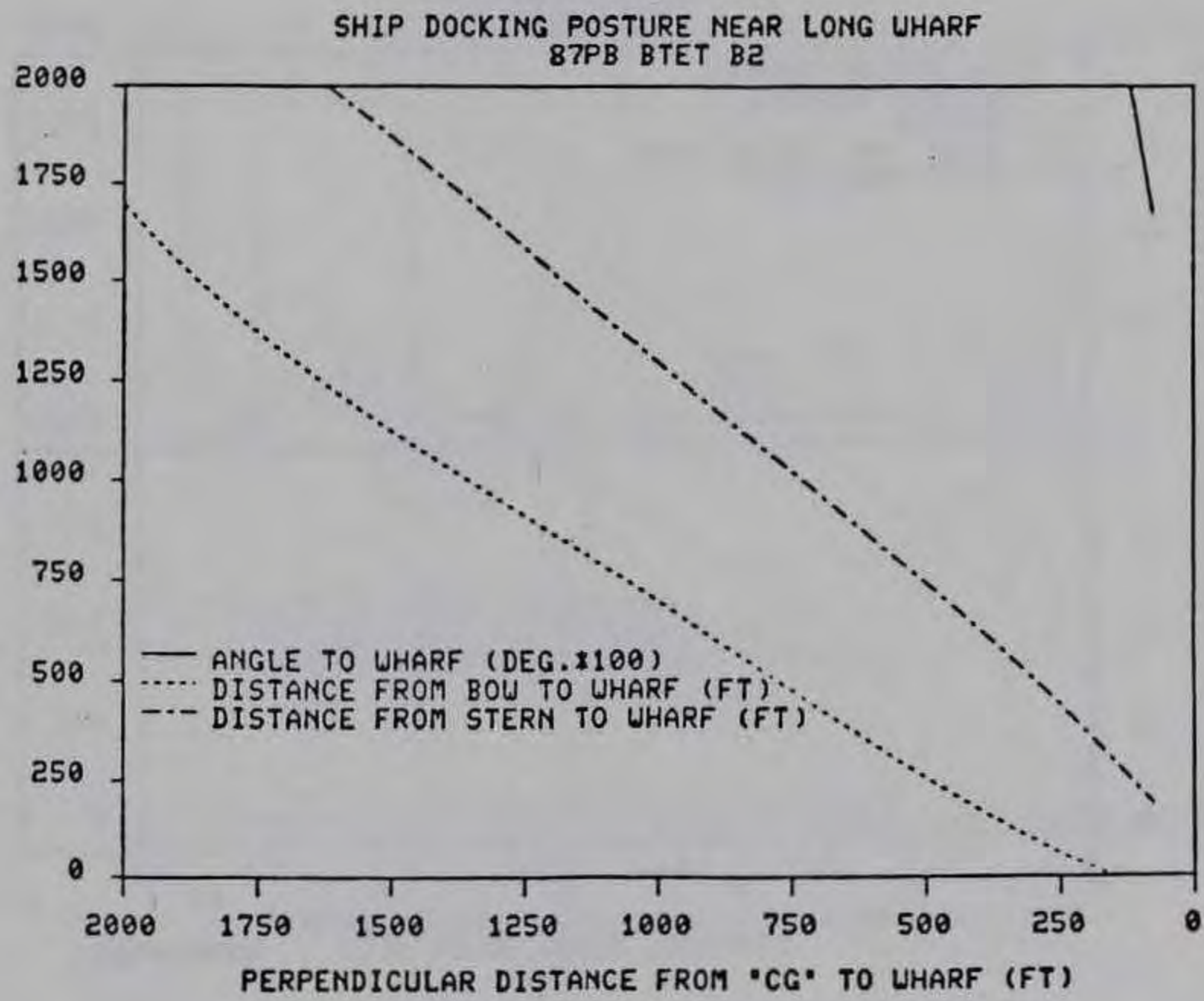
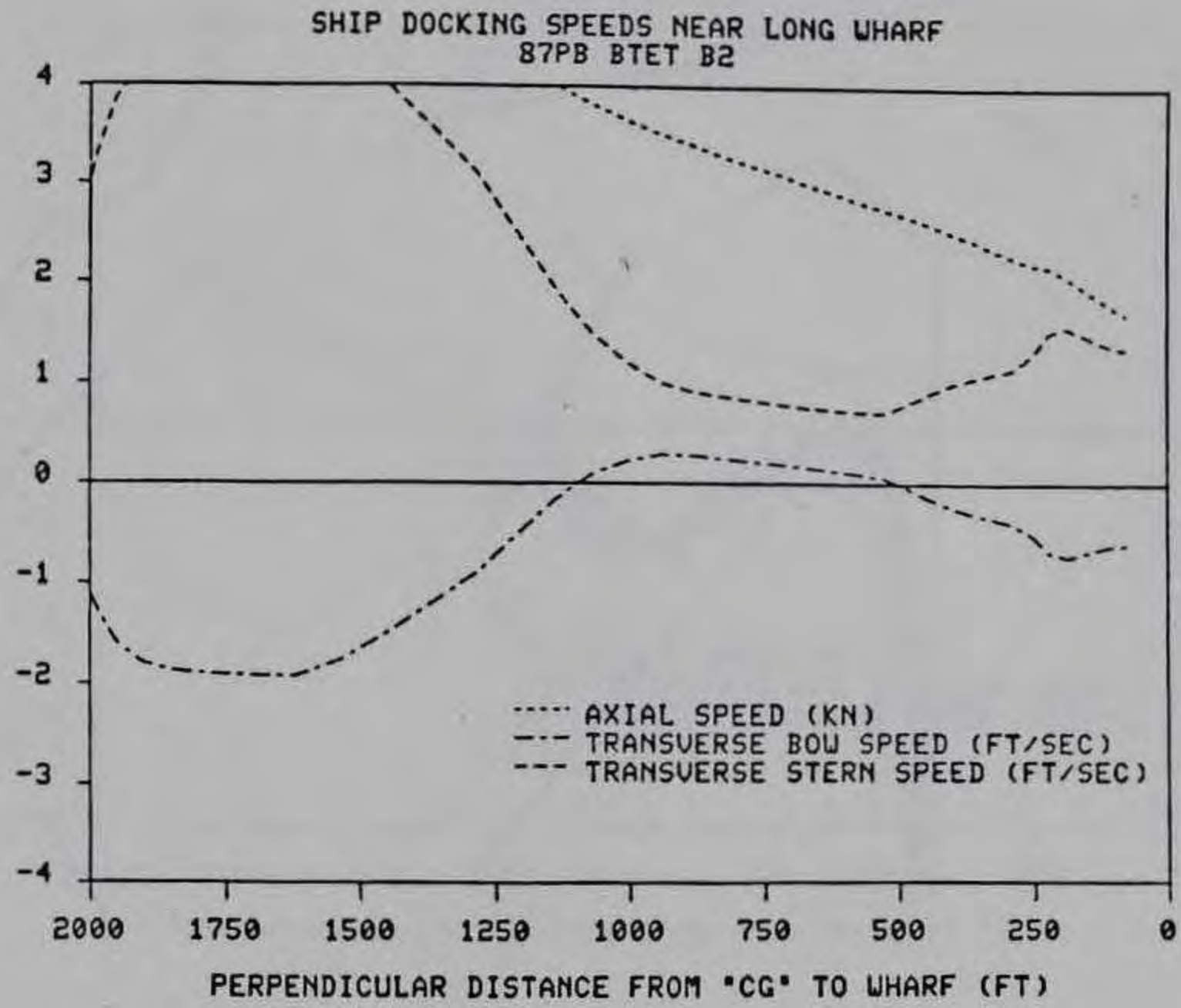

Figure A44. Ship docking speed and posture, 87PB BTET B2

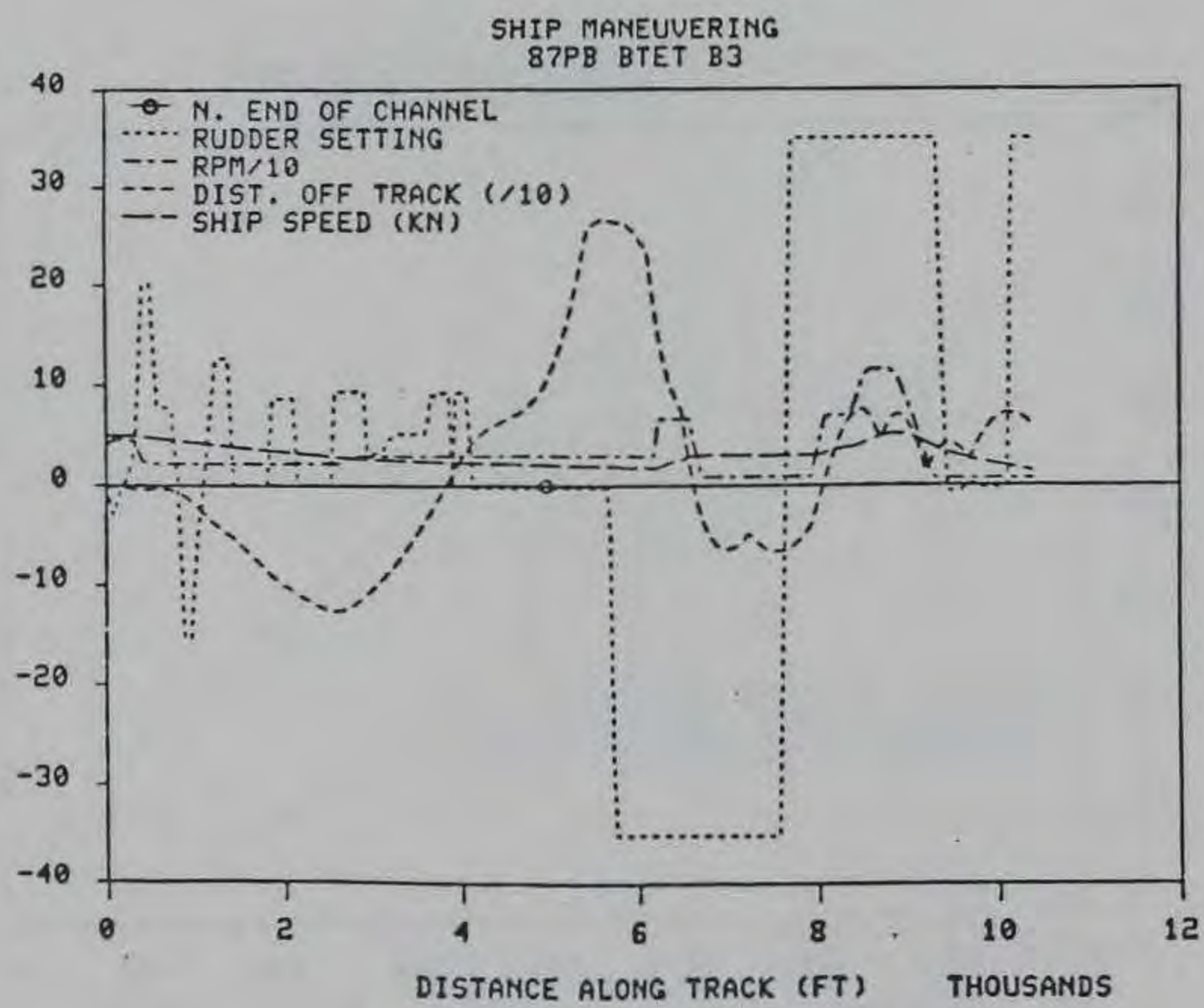
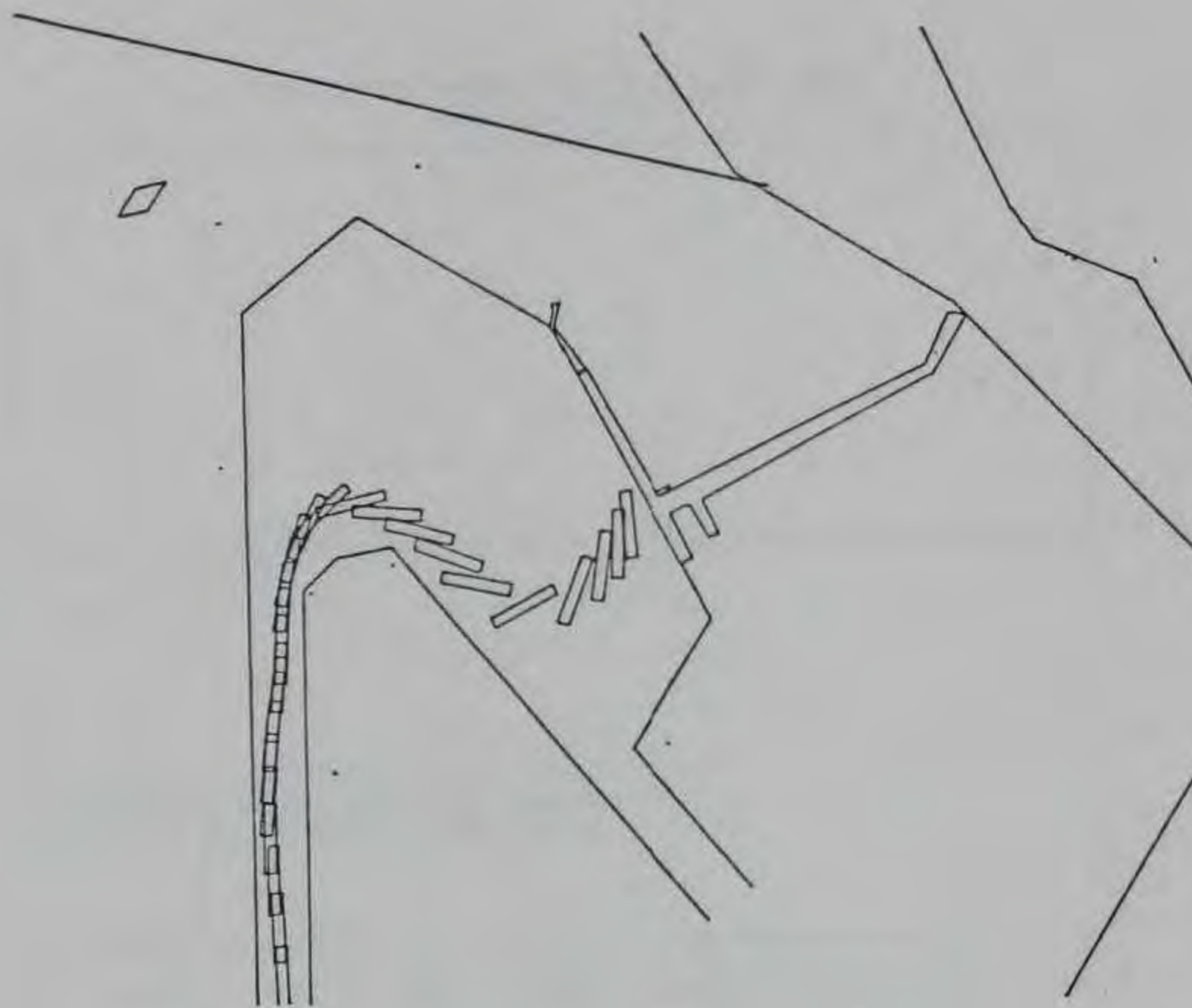

Figure A45. Ship maneuvering, 87PB BTET B3

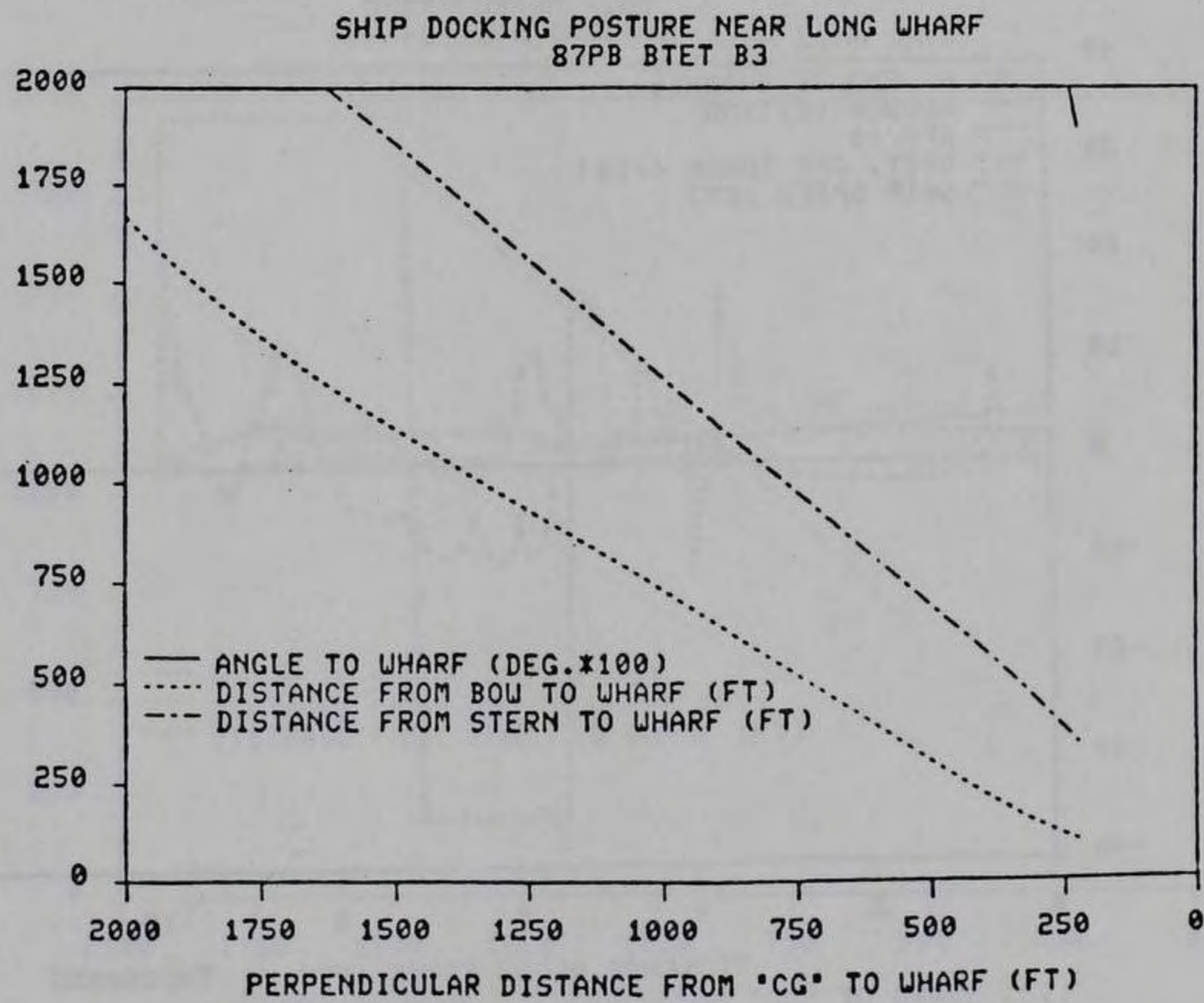
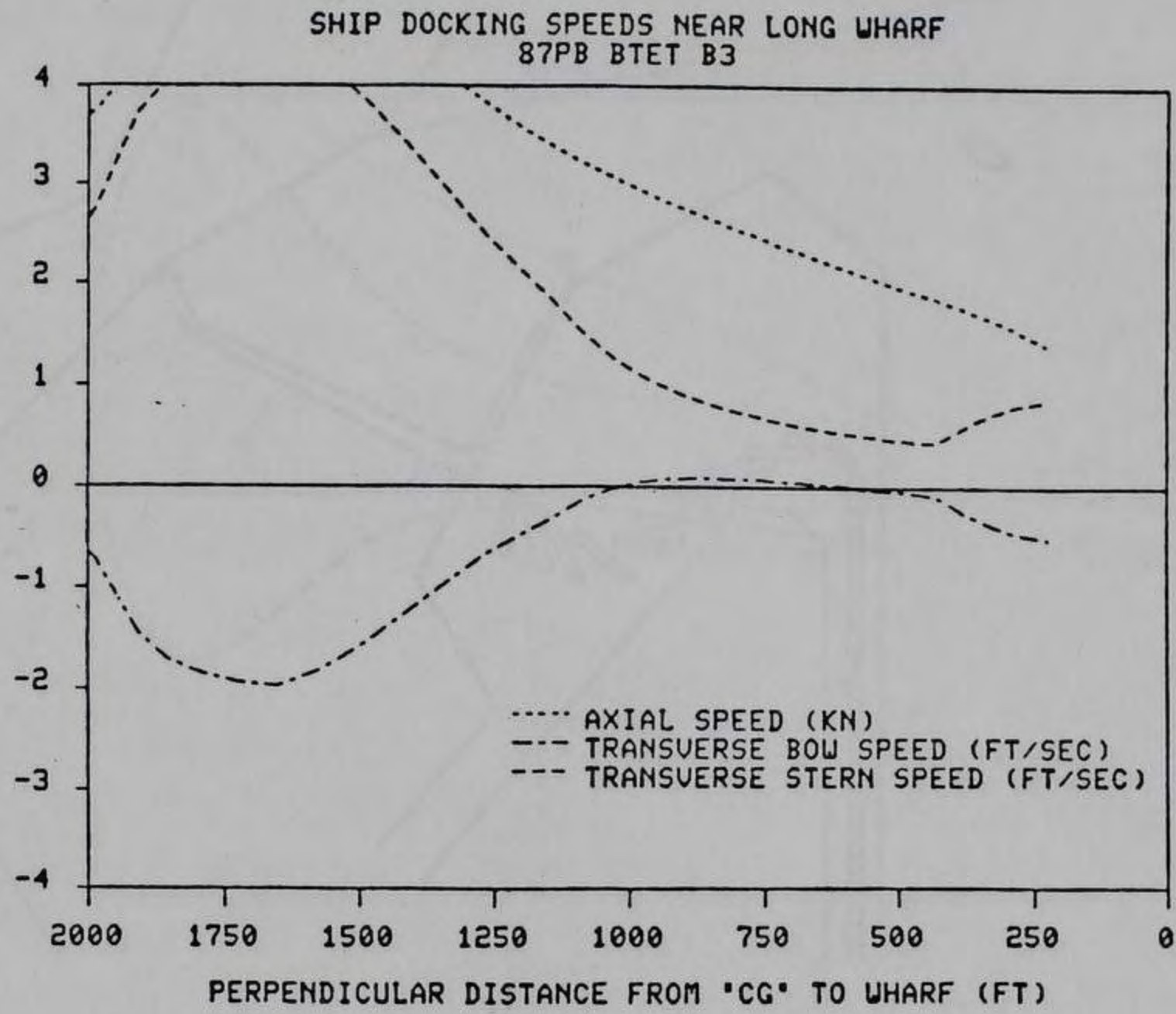

Figure A46. Ship docking speed and posture, 87PB BTET B3

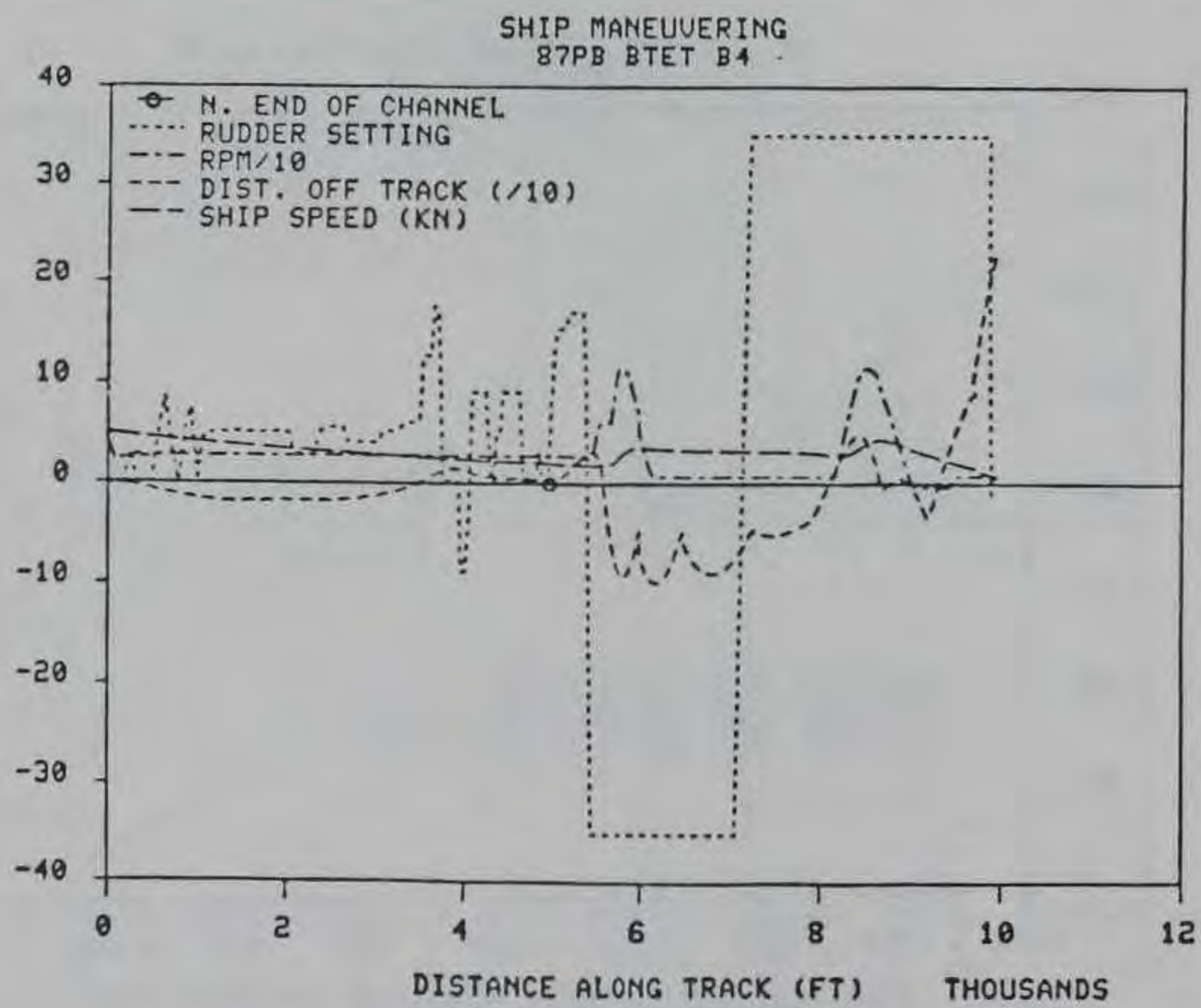
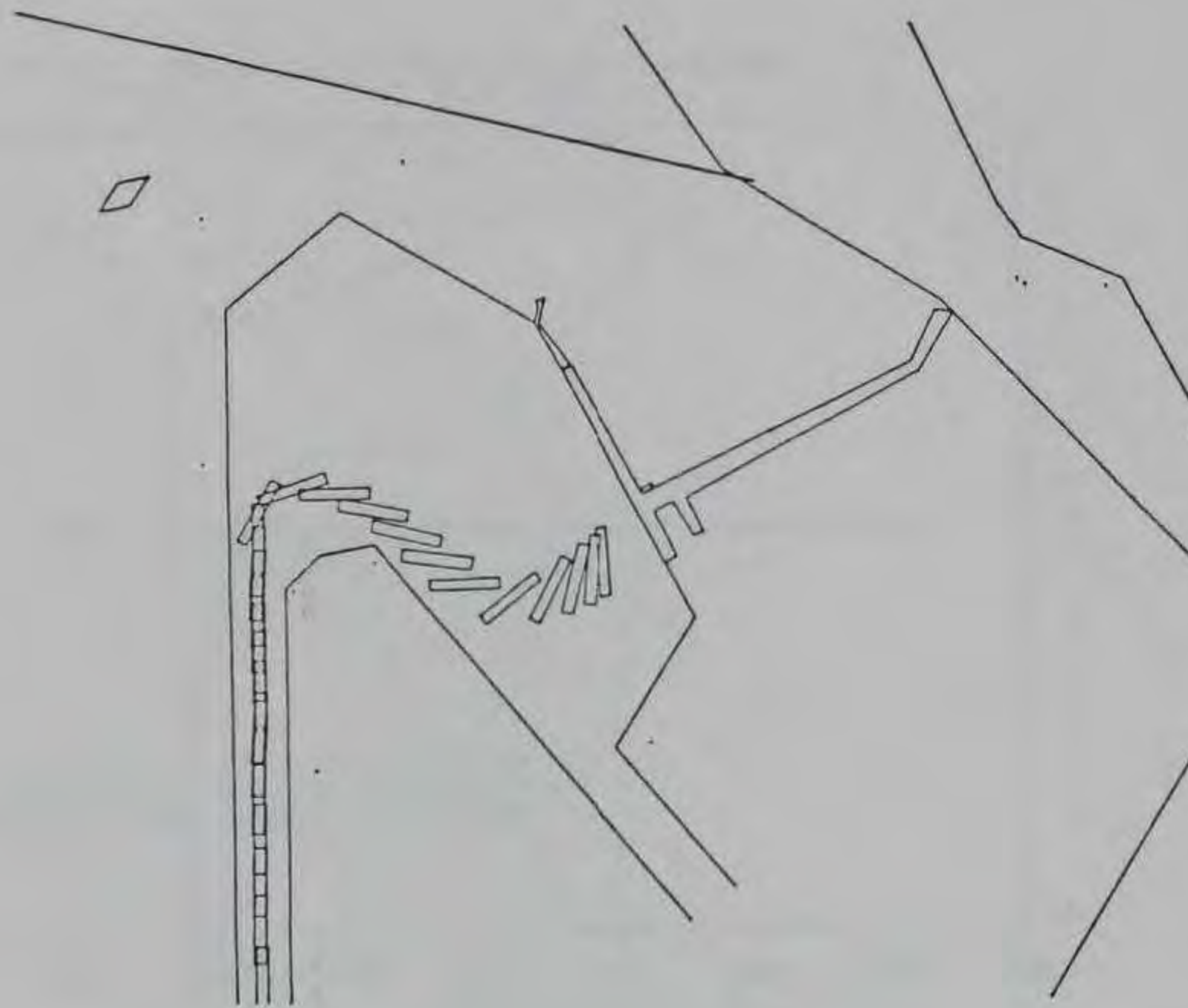

Figure A47. Ship maneuvering, 87PB BTET B4

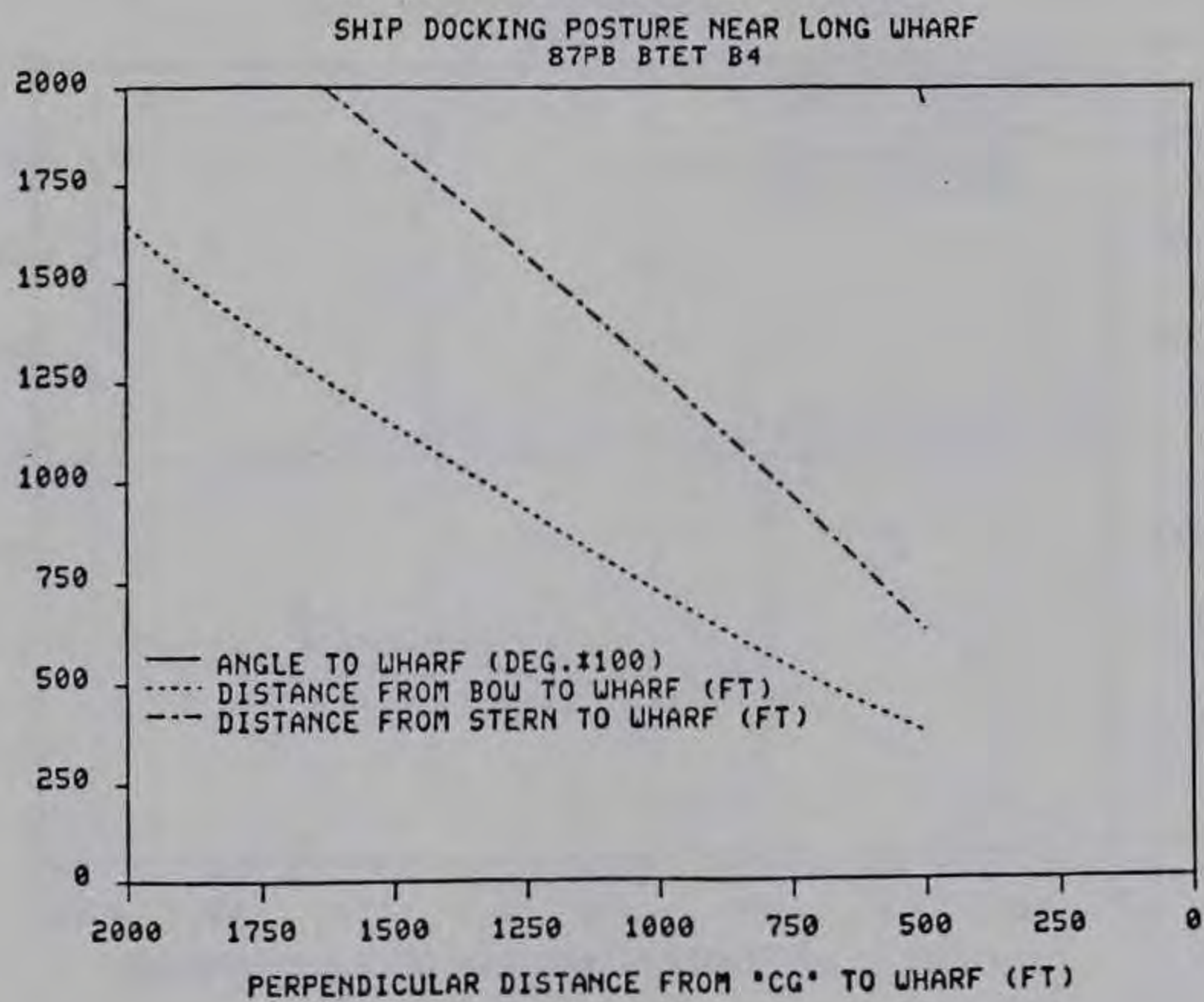
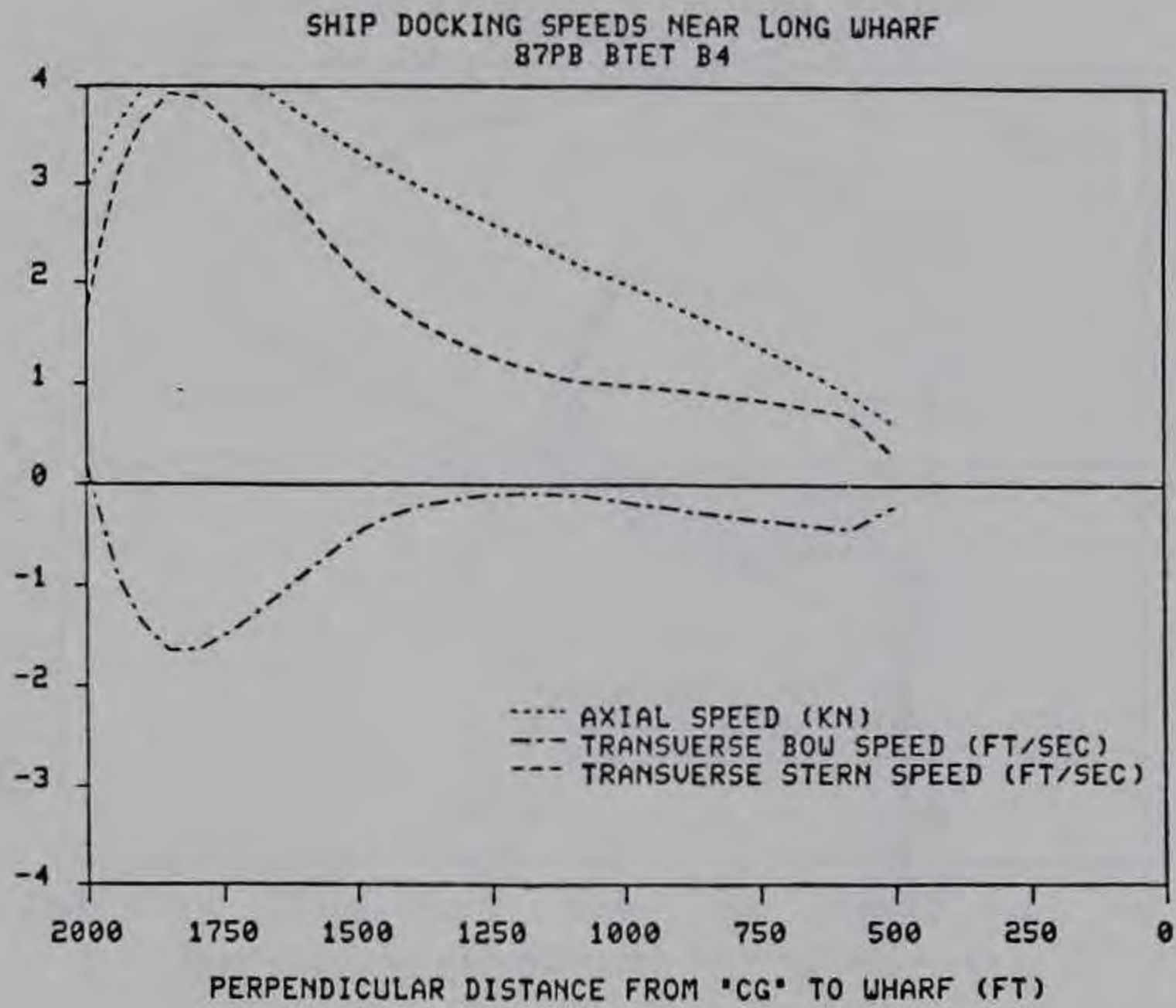

Figure A48. Ship docking speed and posture, 87PB BTET B4

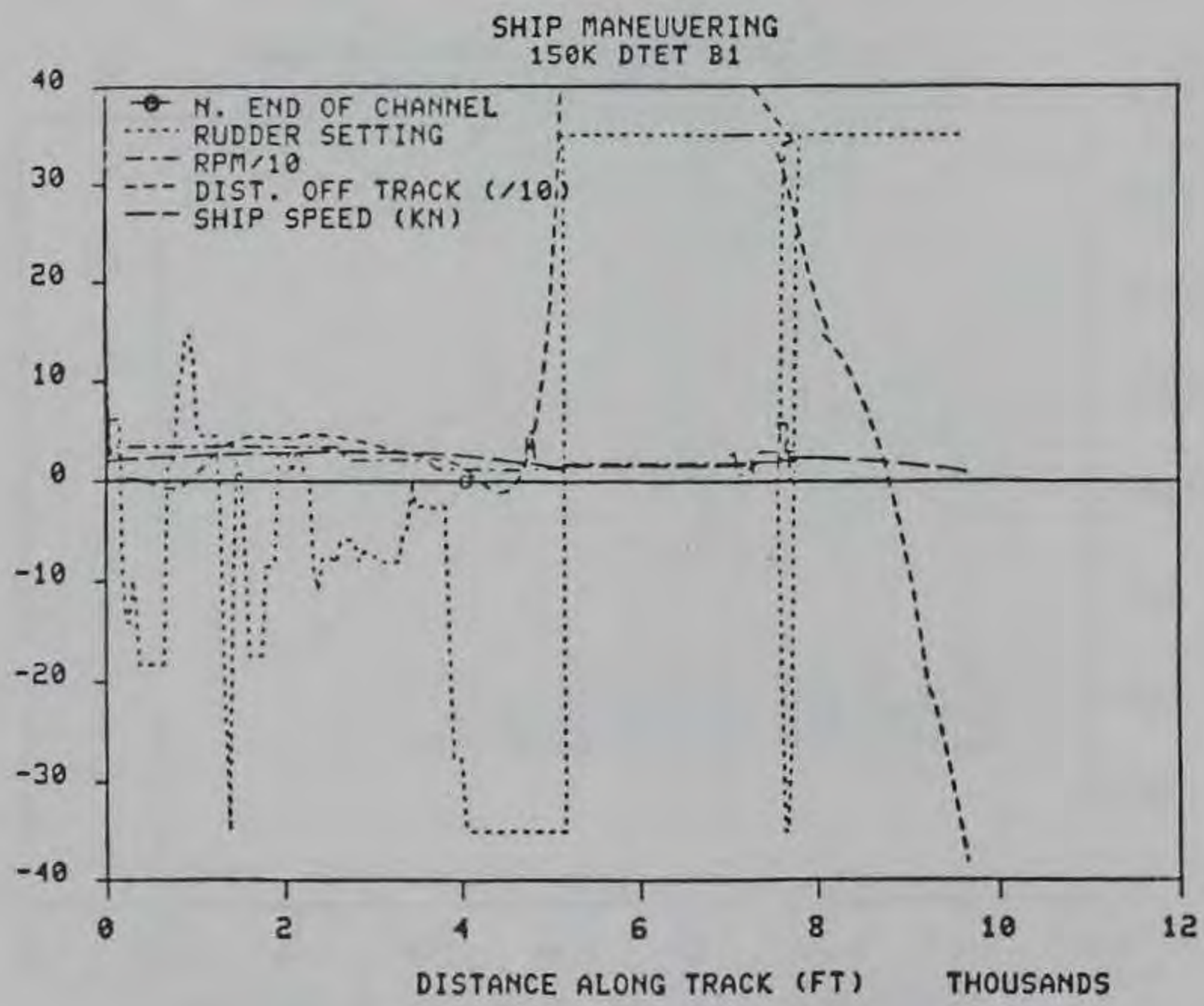
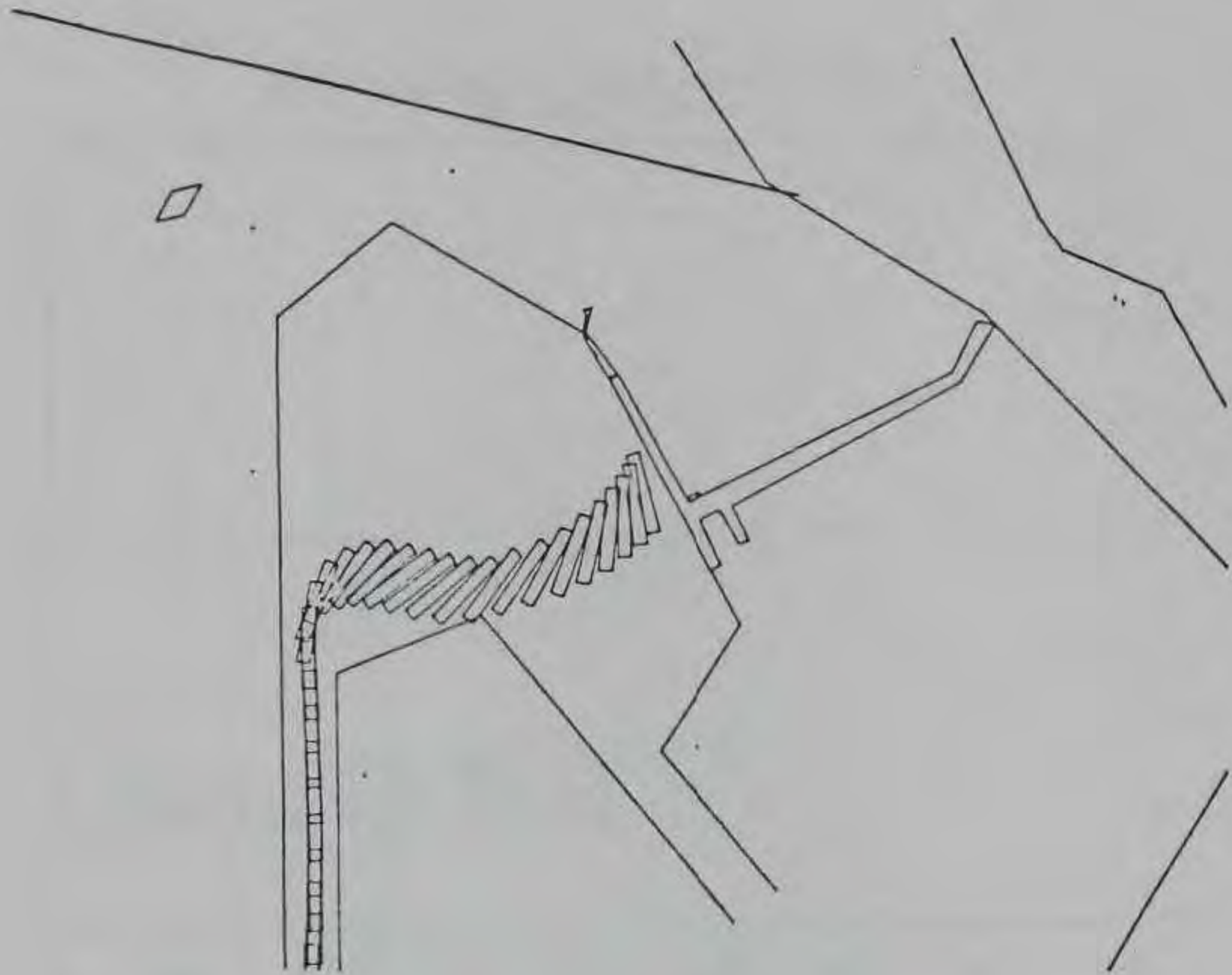

Figure A49. Ship maneuvering, 150K DTET B1

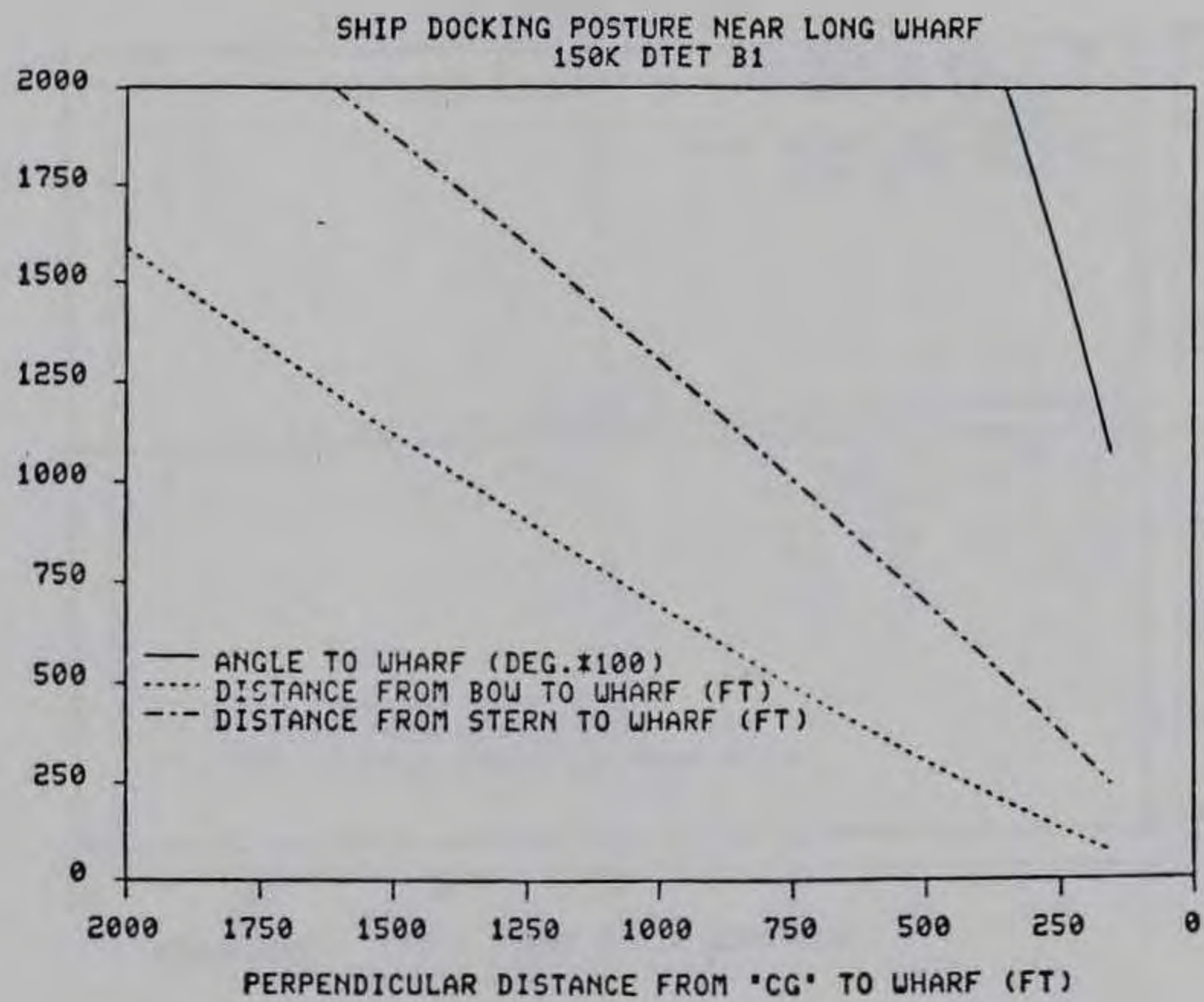
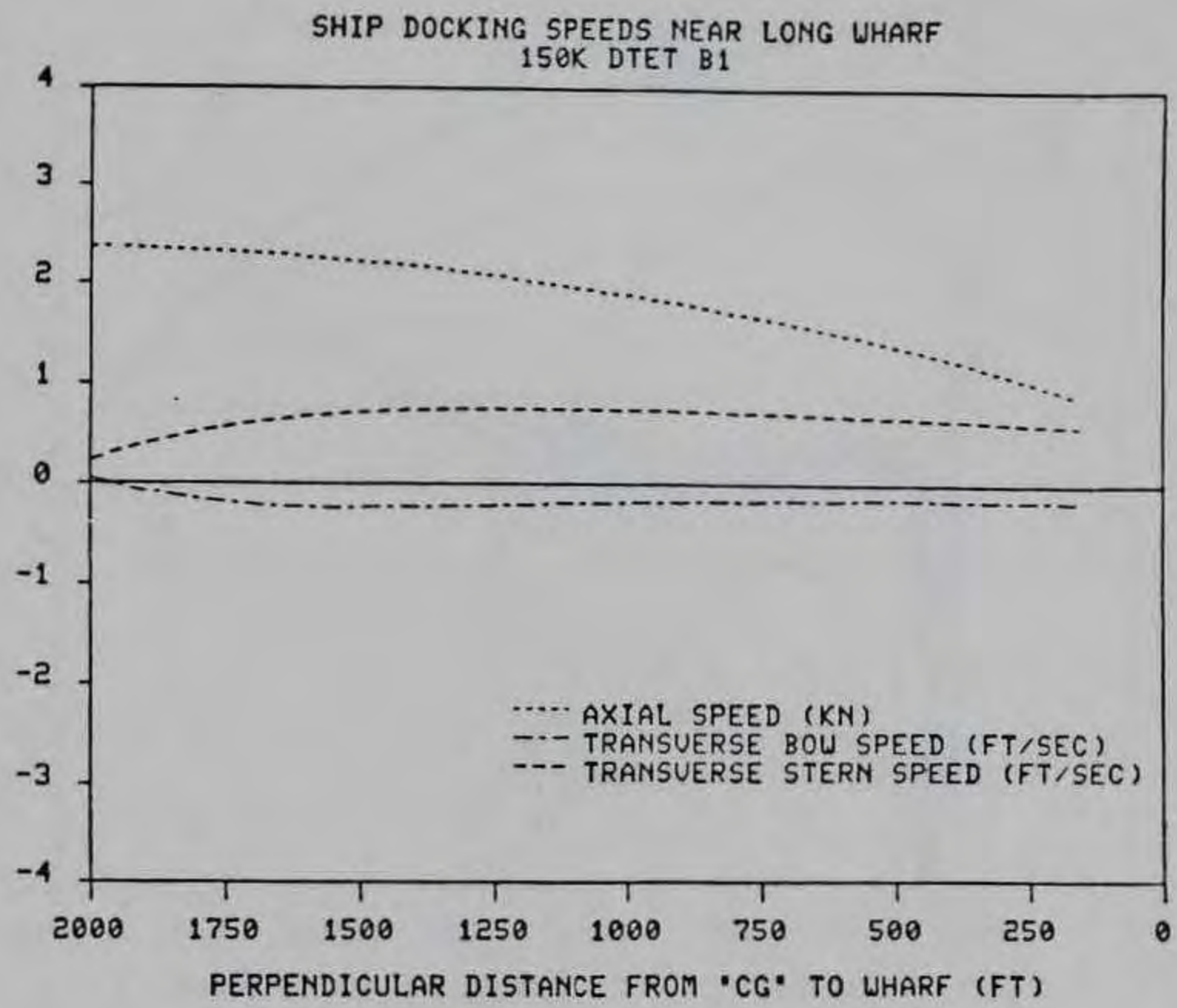

Figure A50. Ship docking speed and posture, 150K DTET B1

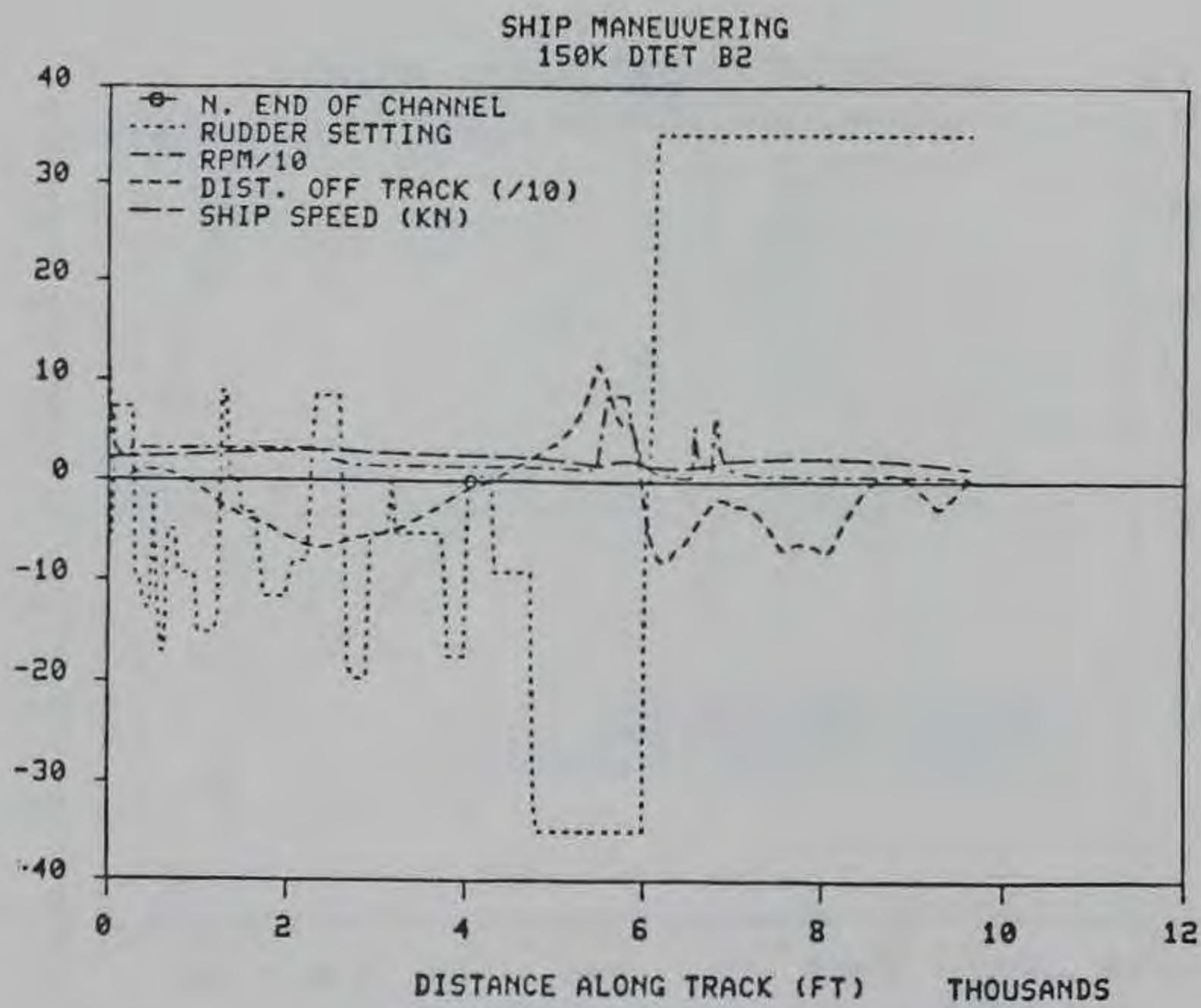
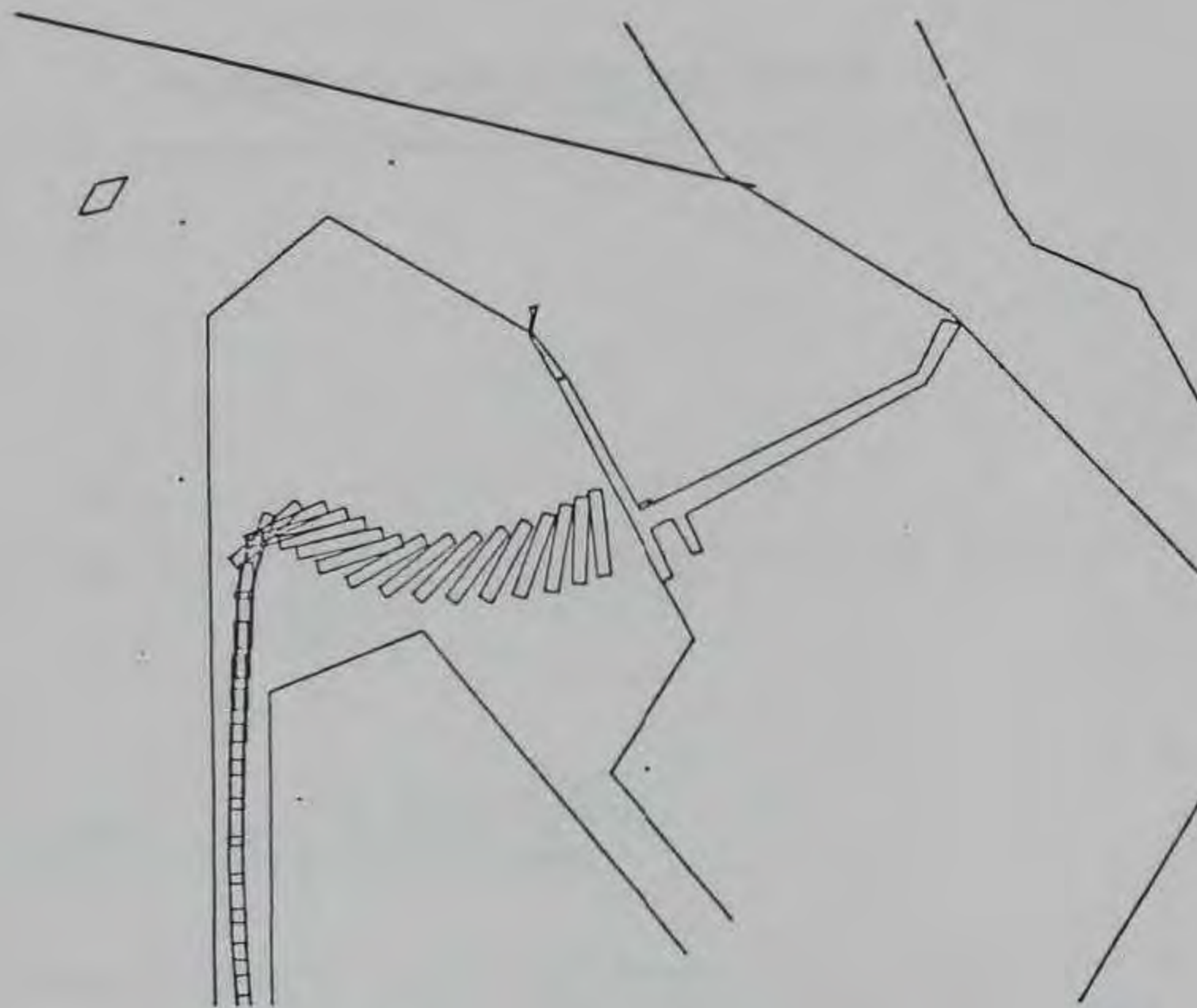

Figure A51. Ship maneuvering, 150K DTET B2

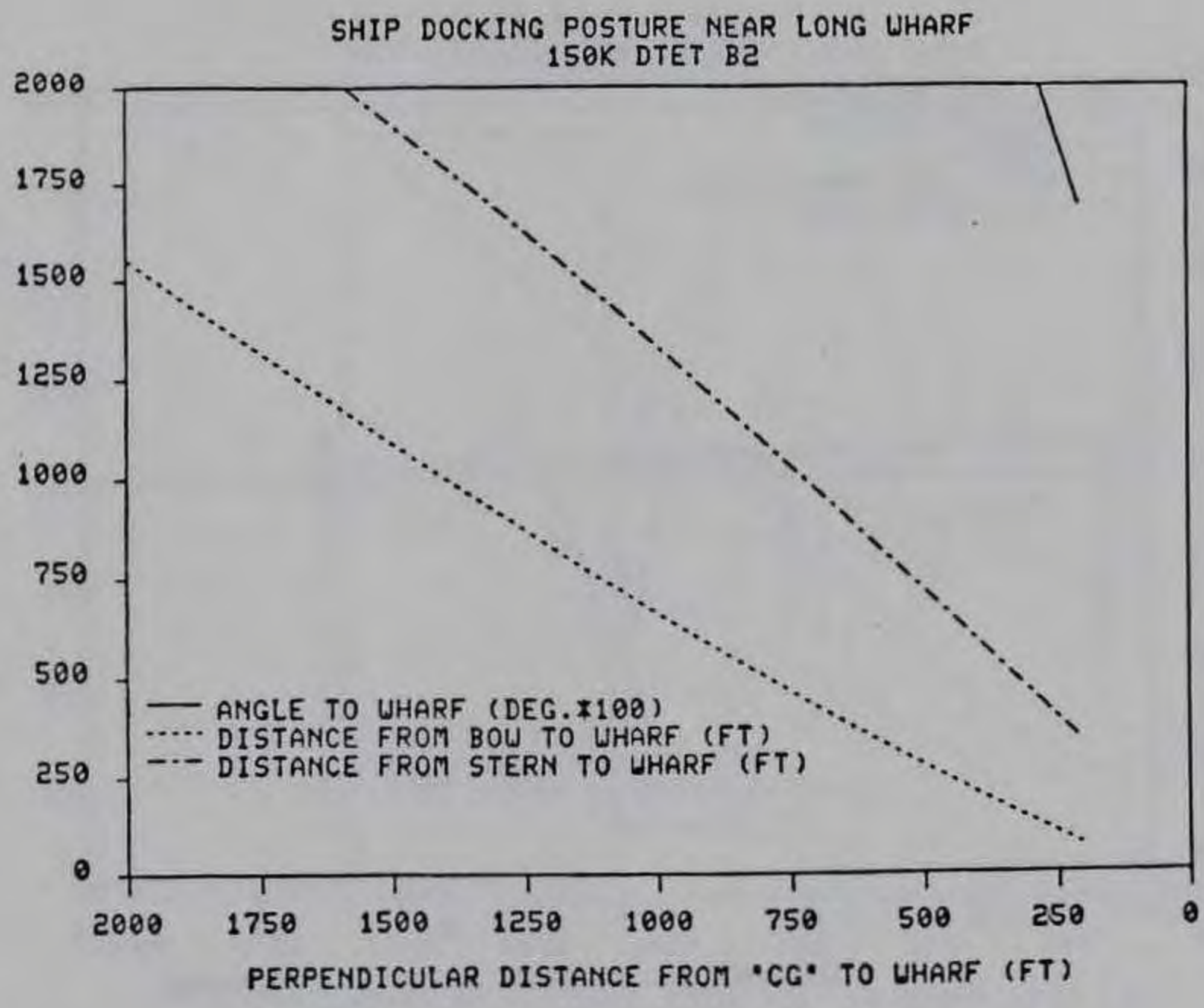
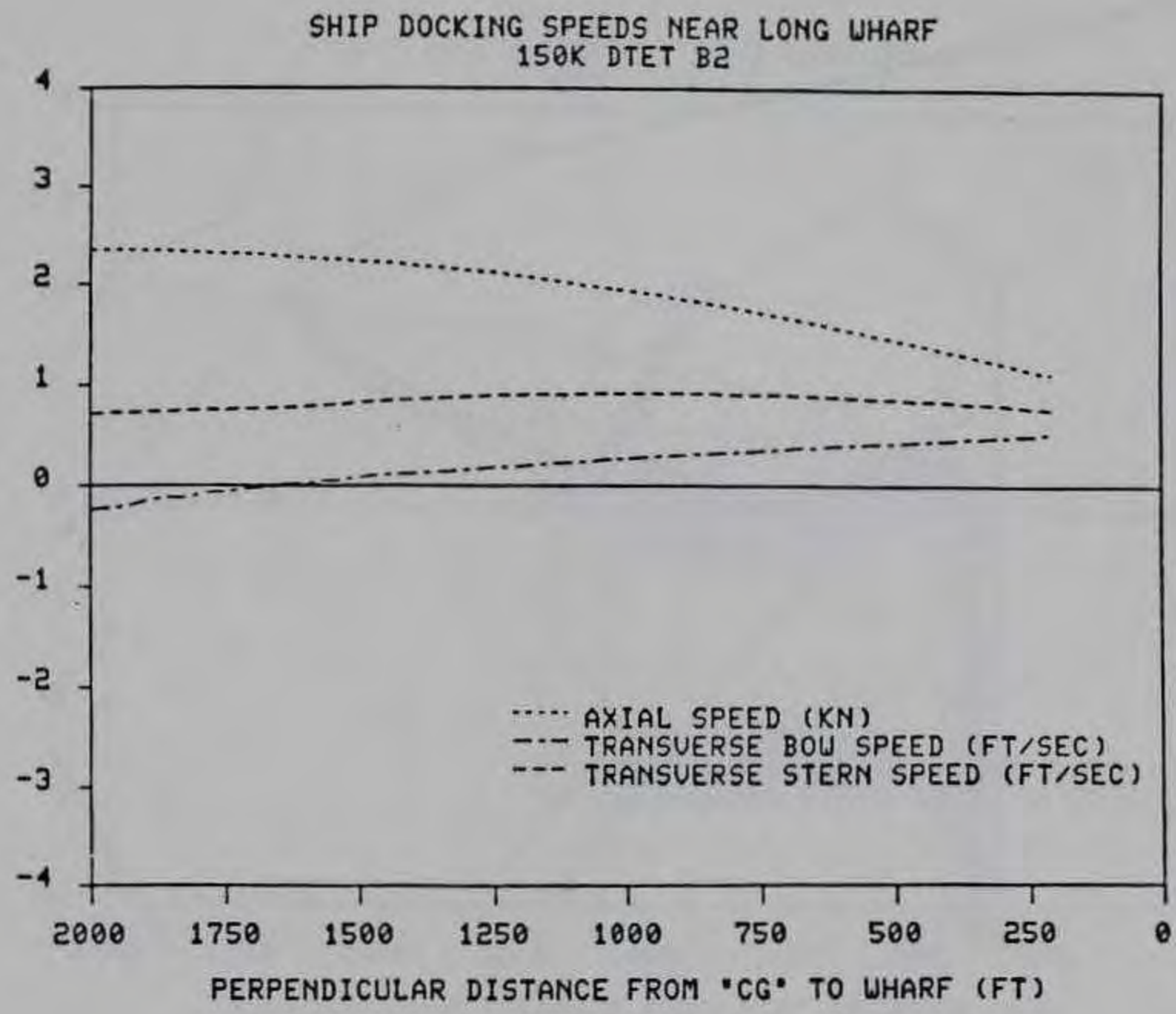

Figure A52. Ship docking speed and posture, 150K DTET B2

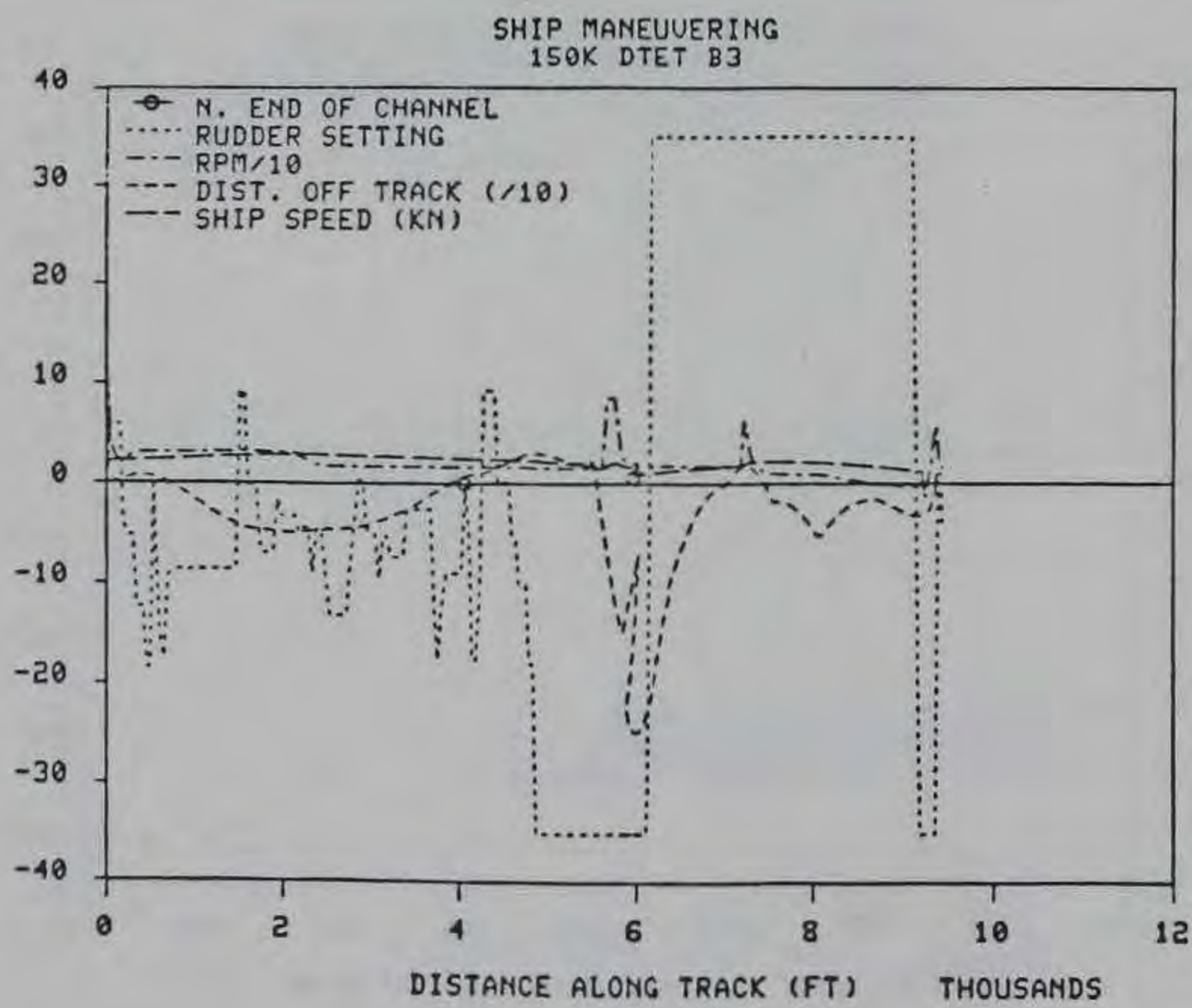
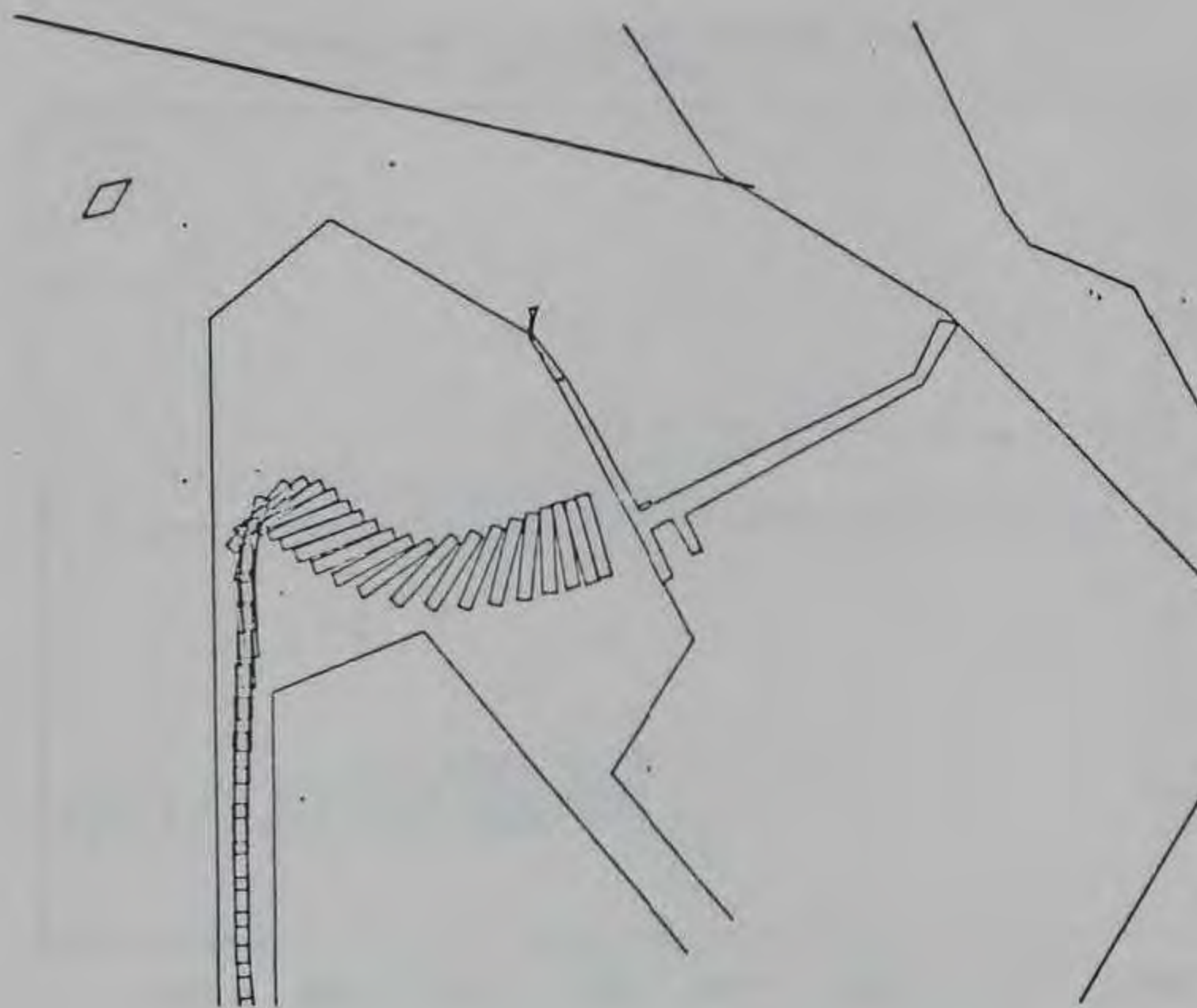

Figure A53. Ship maneuvering, 150K DTET B3

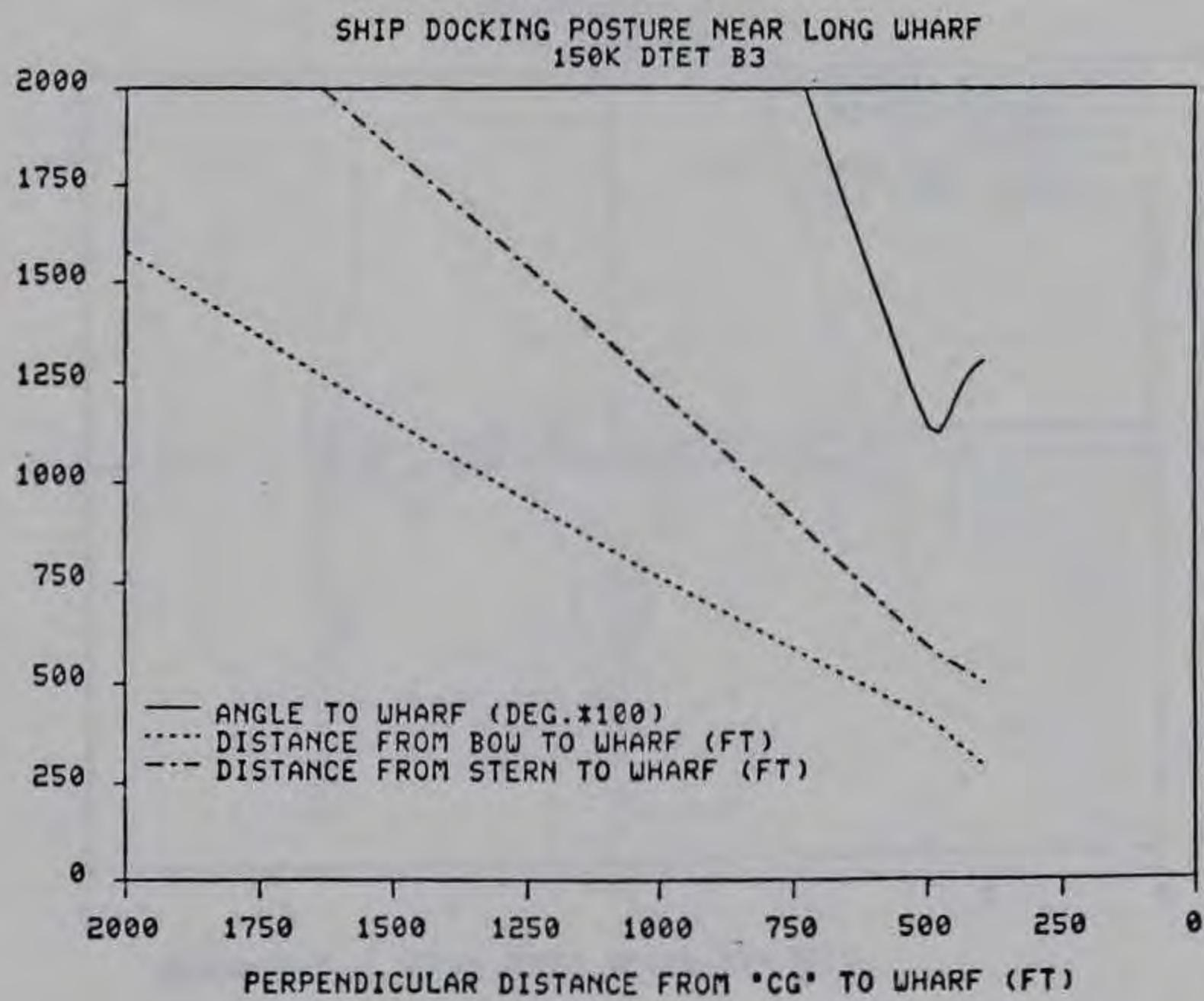
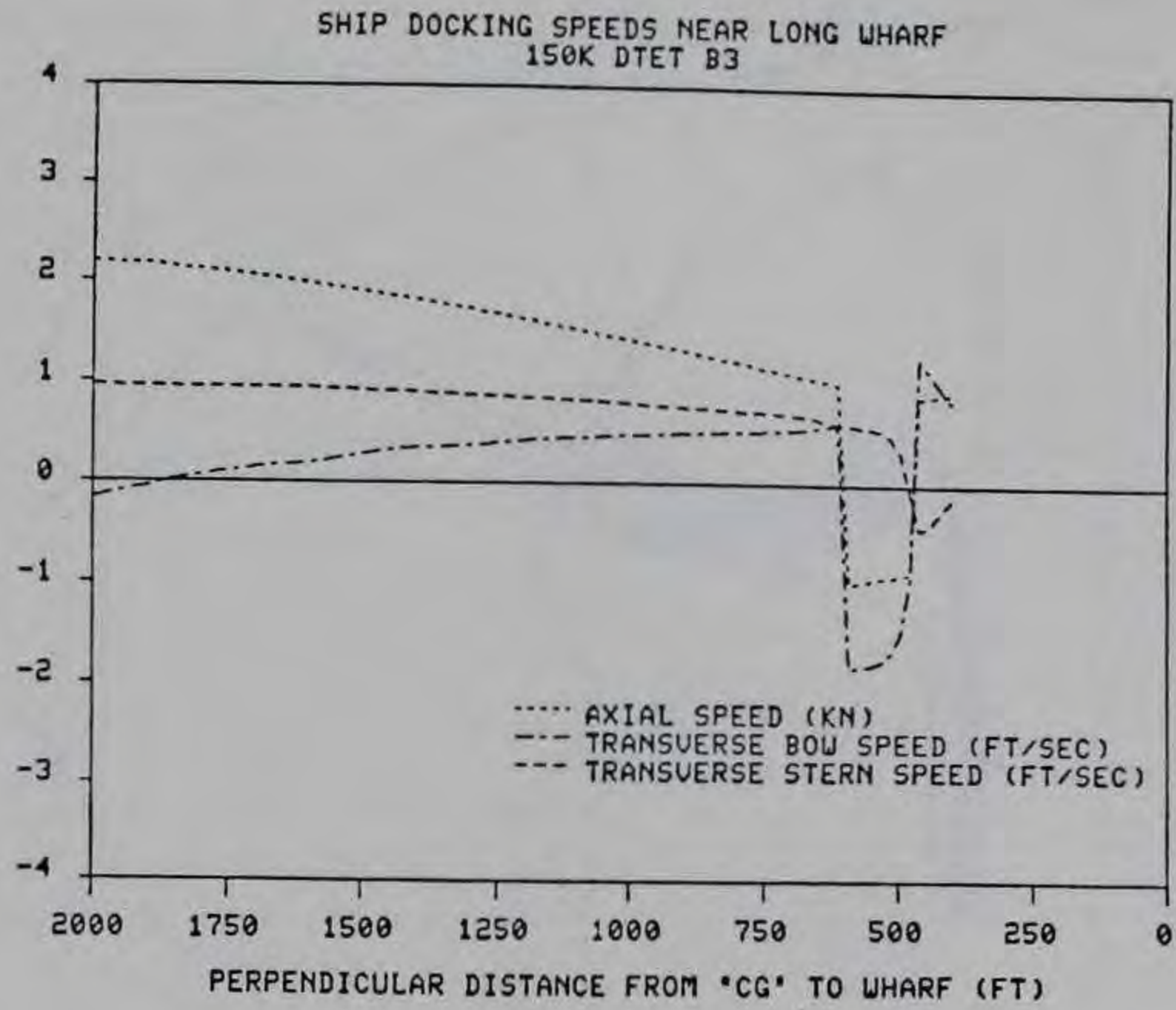

Figure A54. Ship docking speed and posture, 150K DTET B3

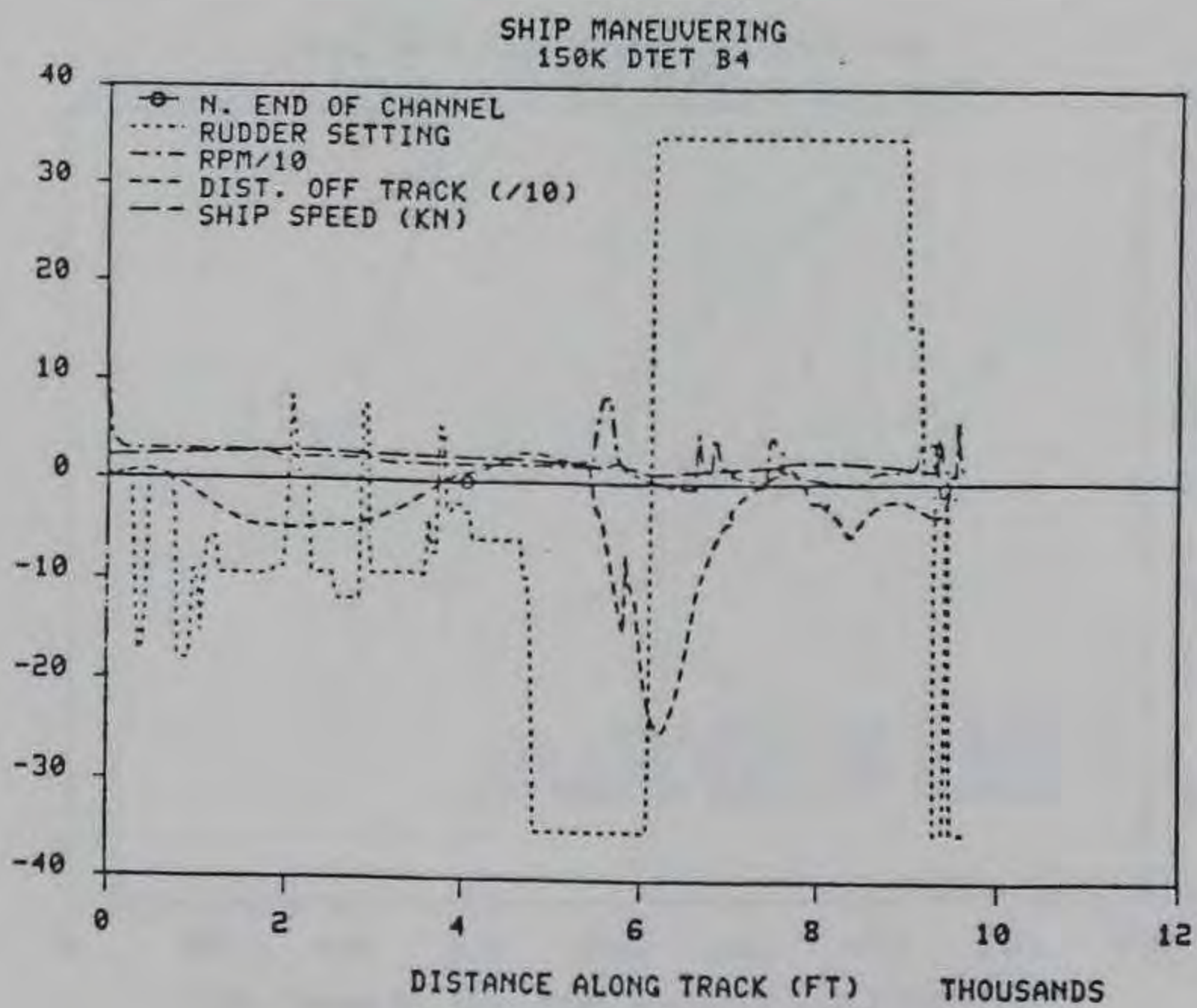
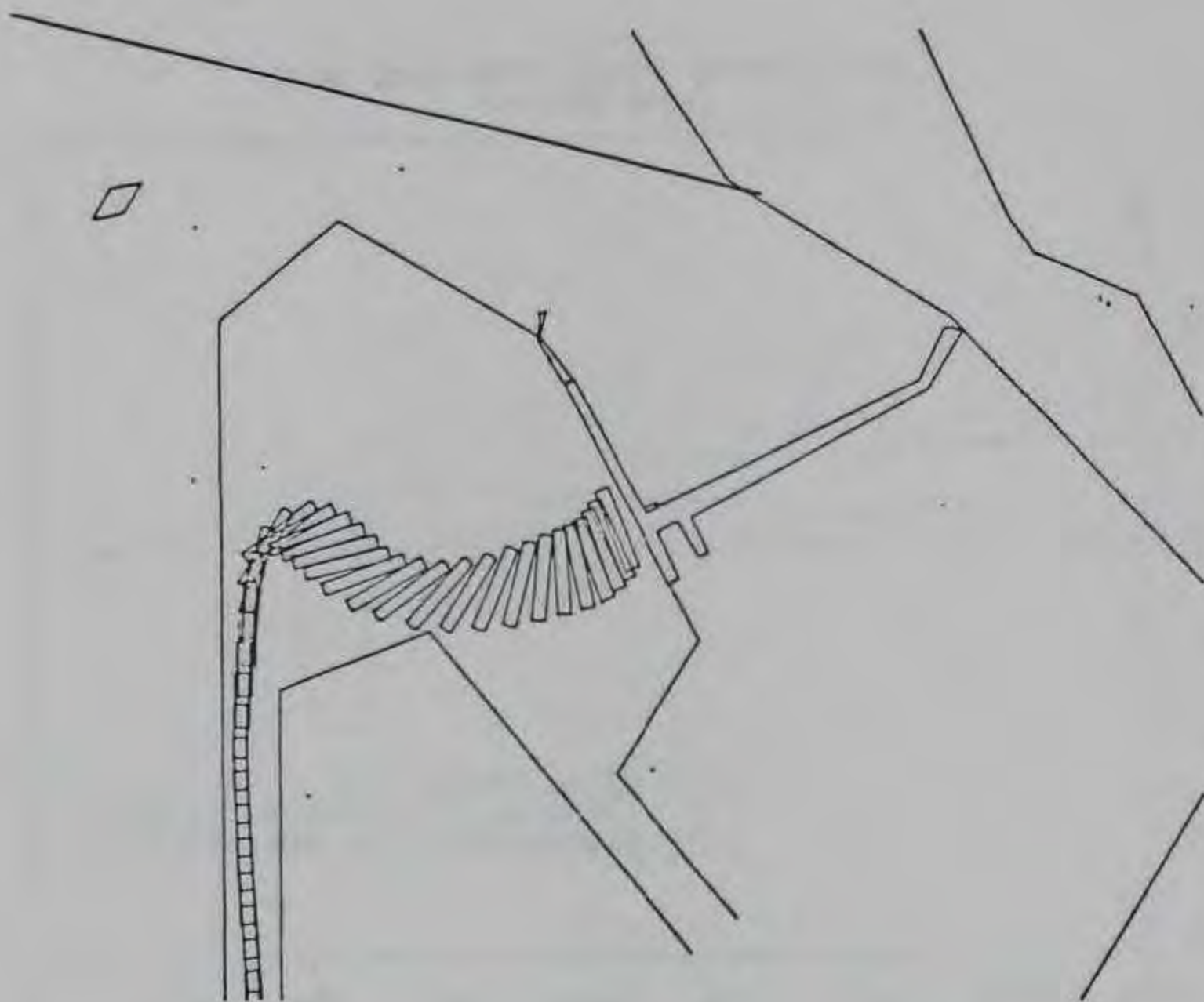

Figure A55. Ship maneuvering, 150K DTET B4

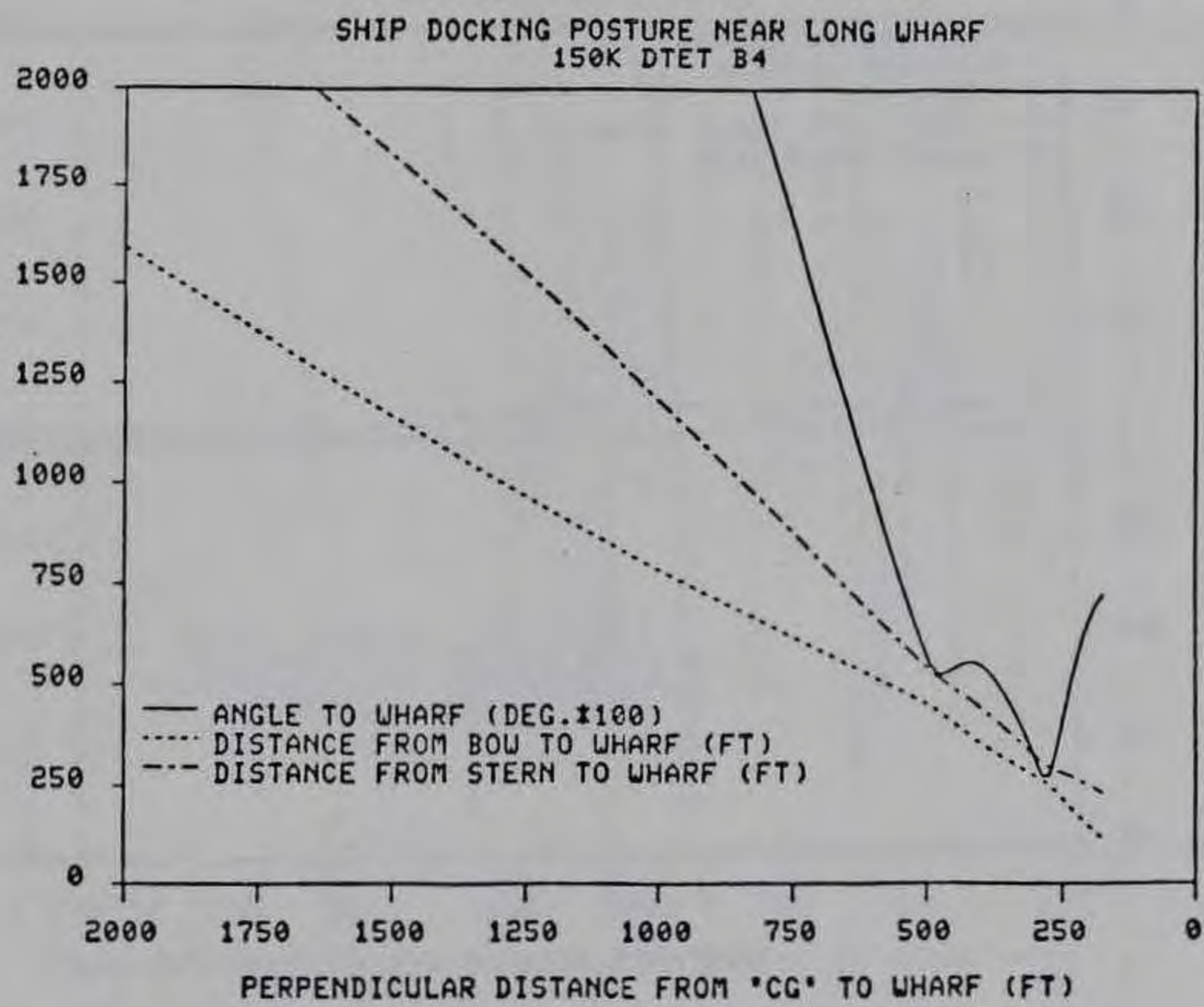
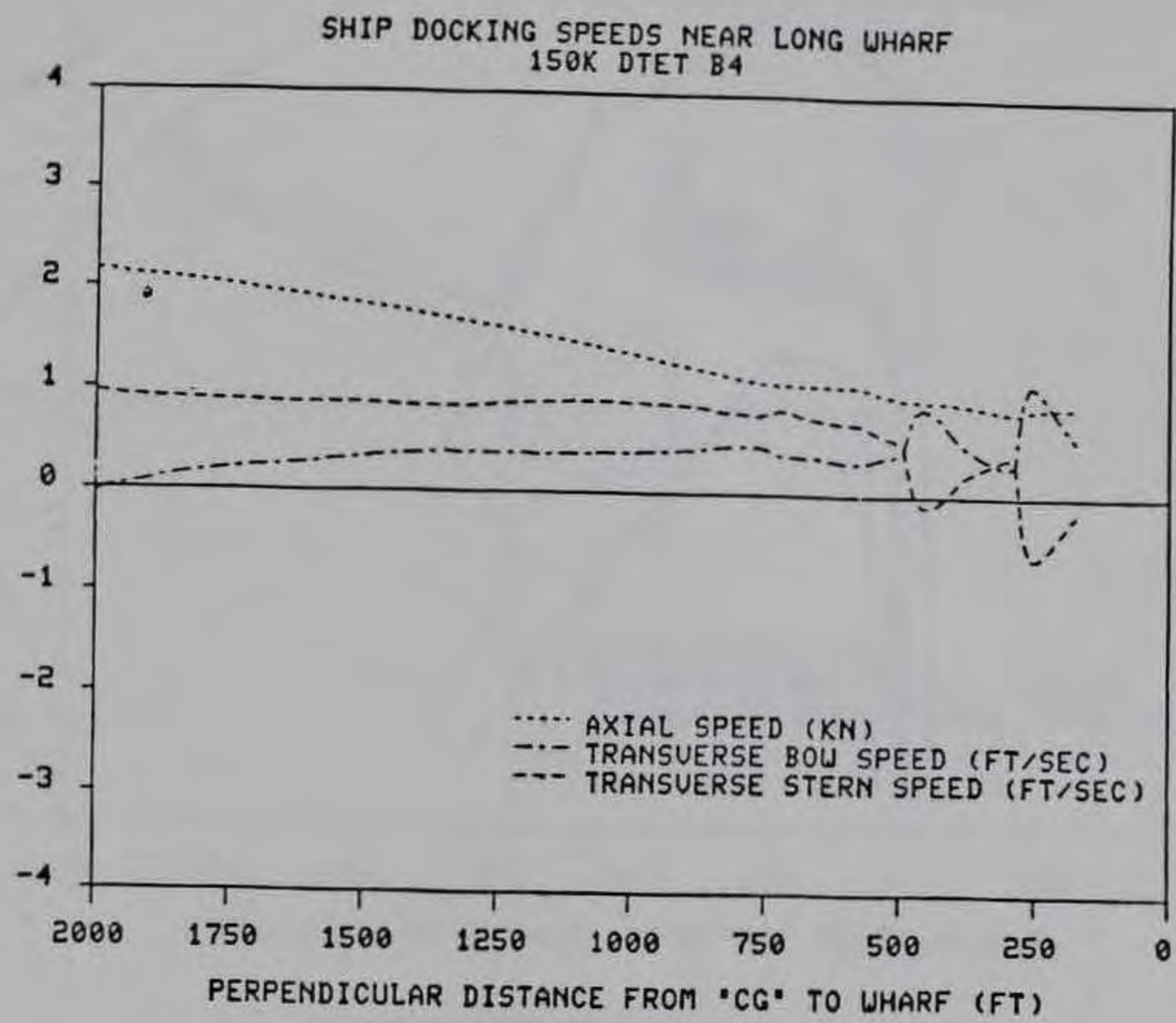

Figure A56. Ship docking speed and posture, 150K DTET B4

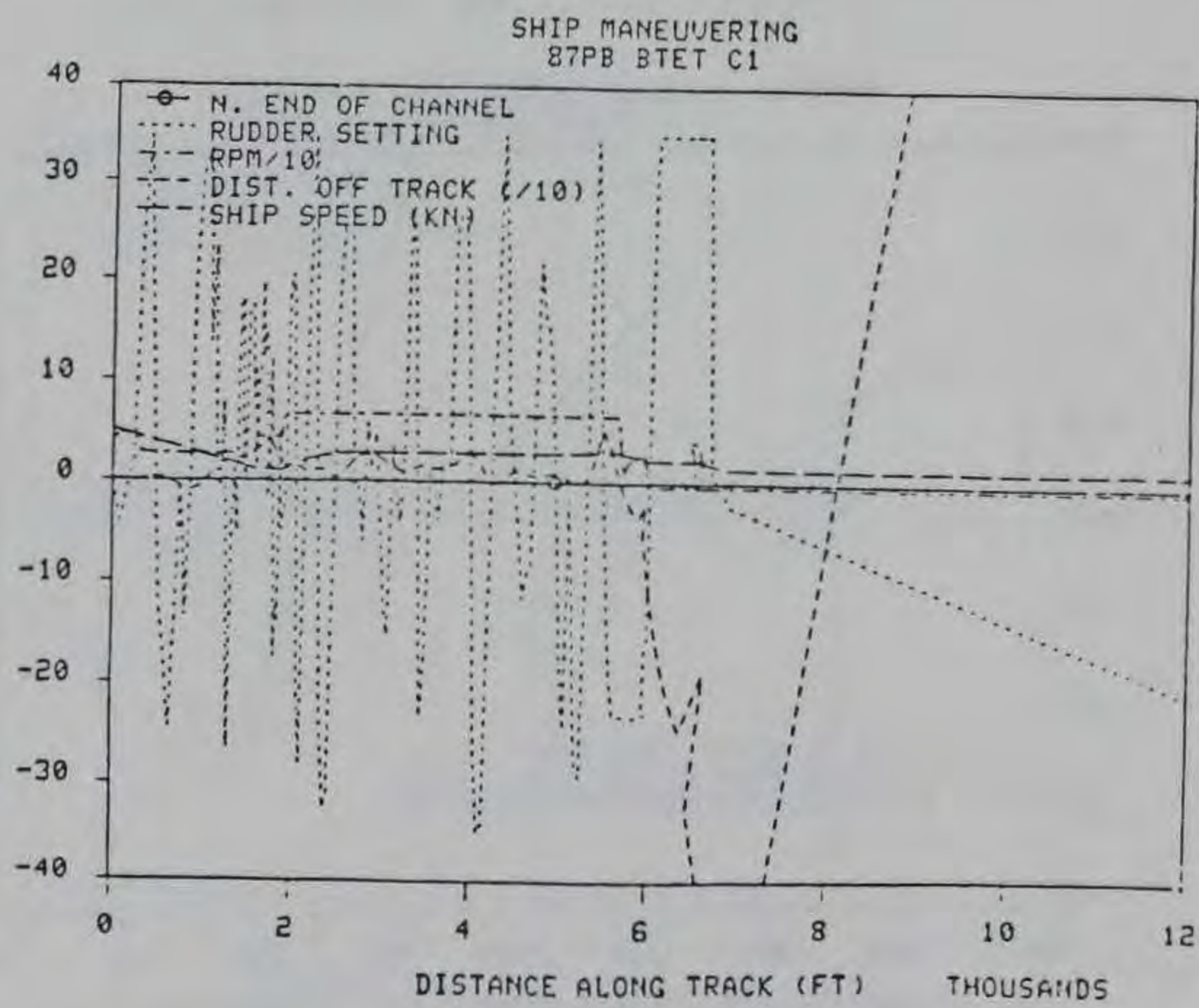
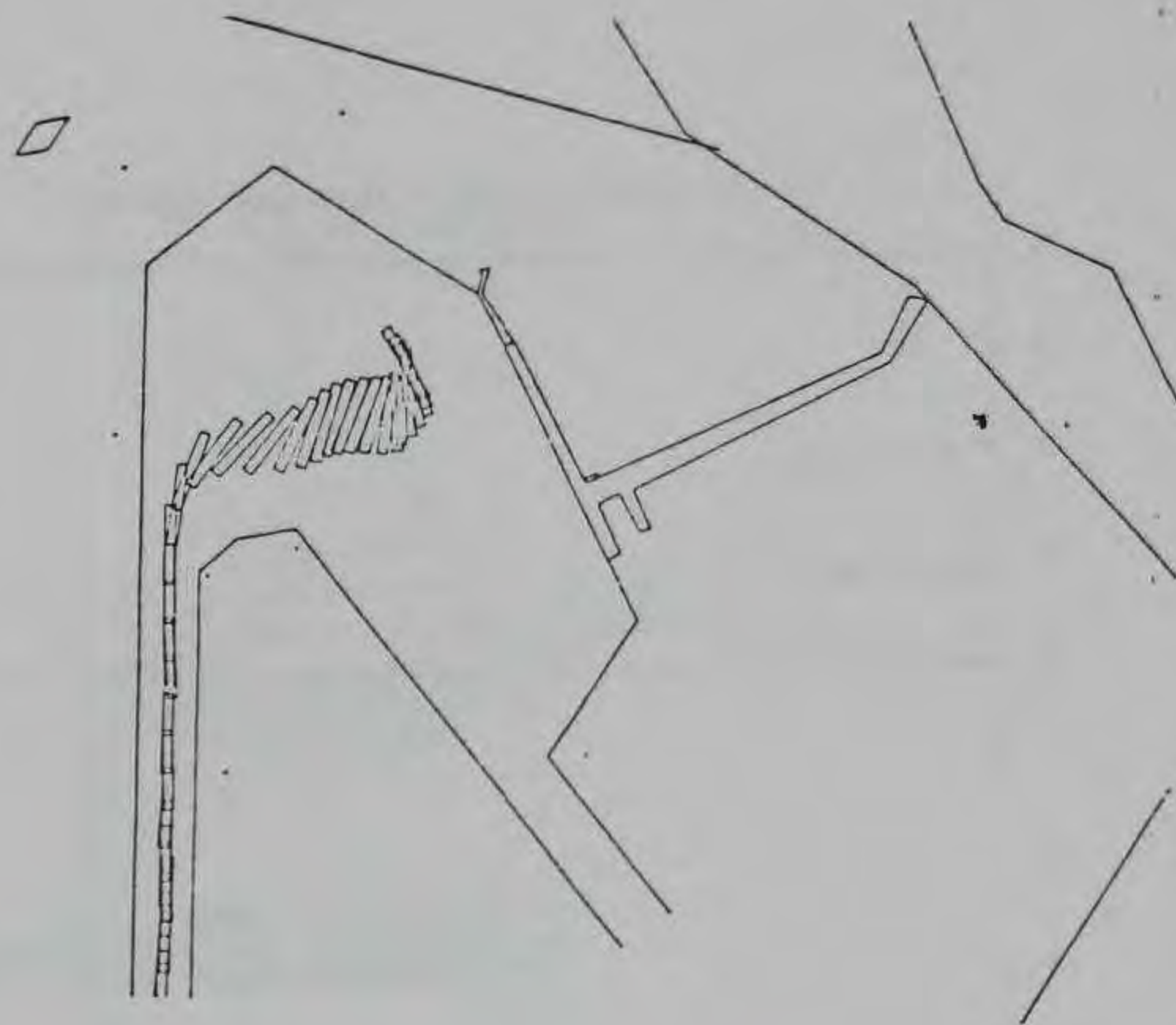

Figure A57. Ship maneuvering, 87PB BTET C1

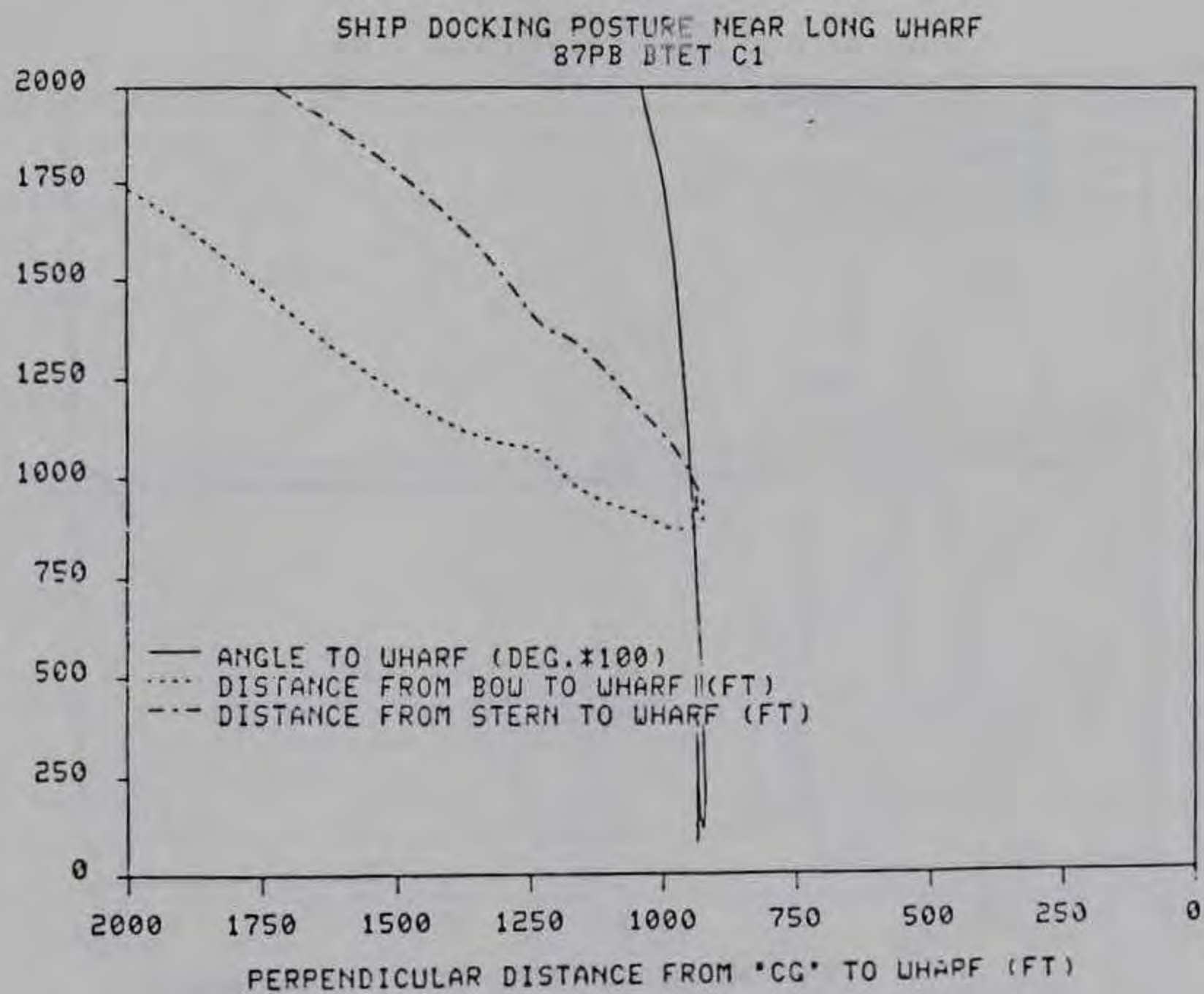
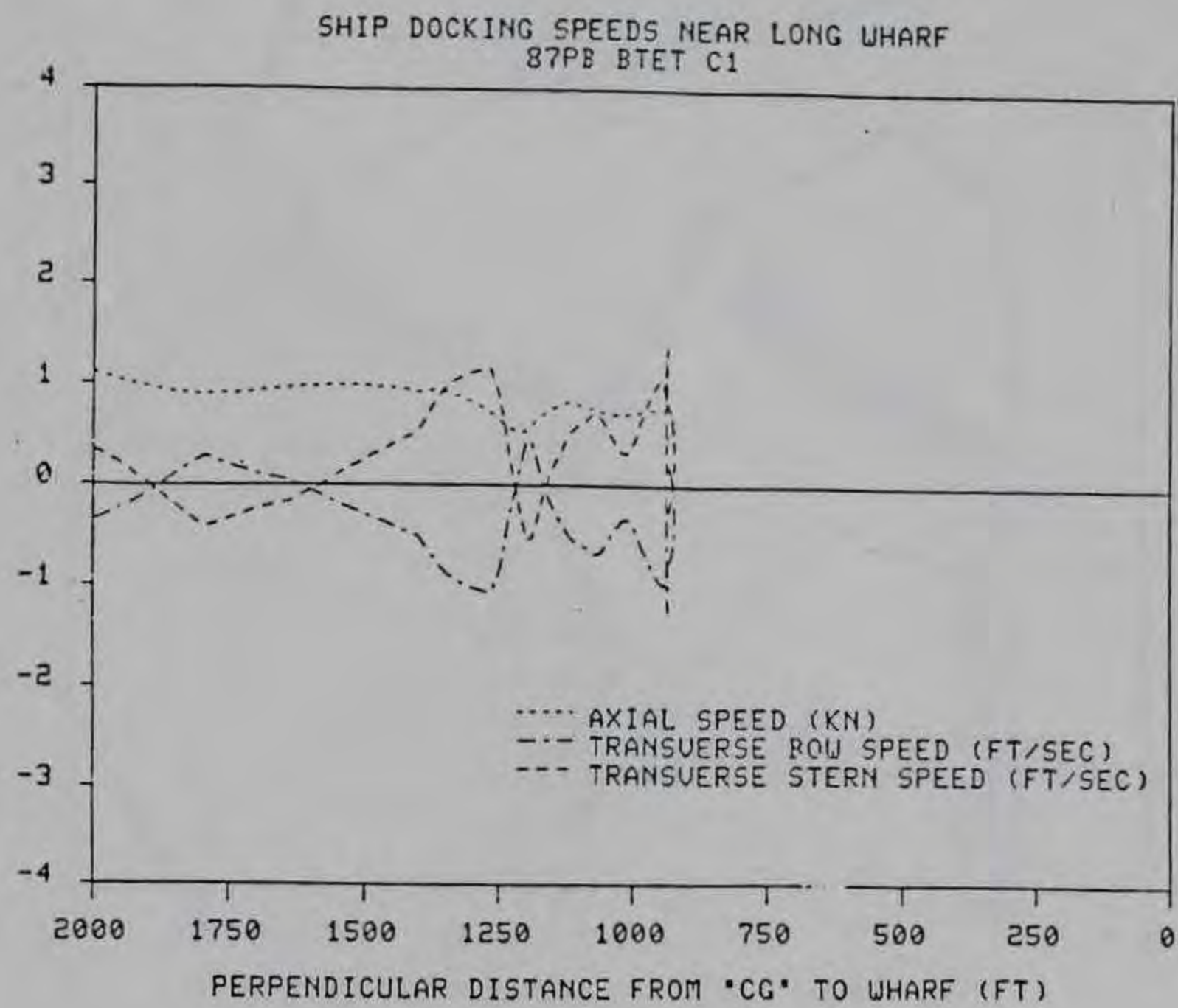

Figure A58. Ship docking speed and posture, 87PB BTET C1

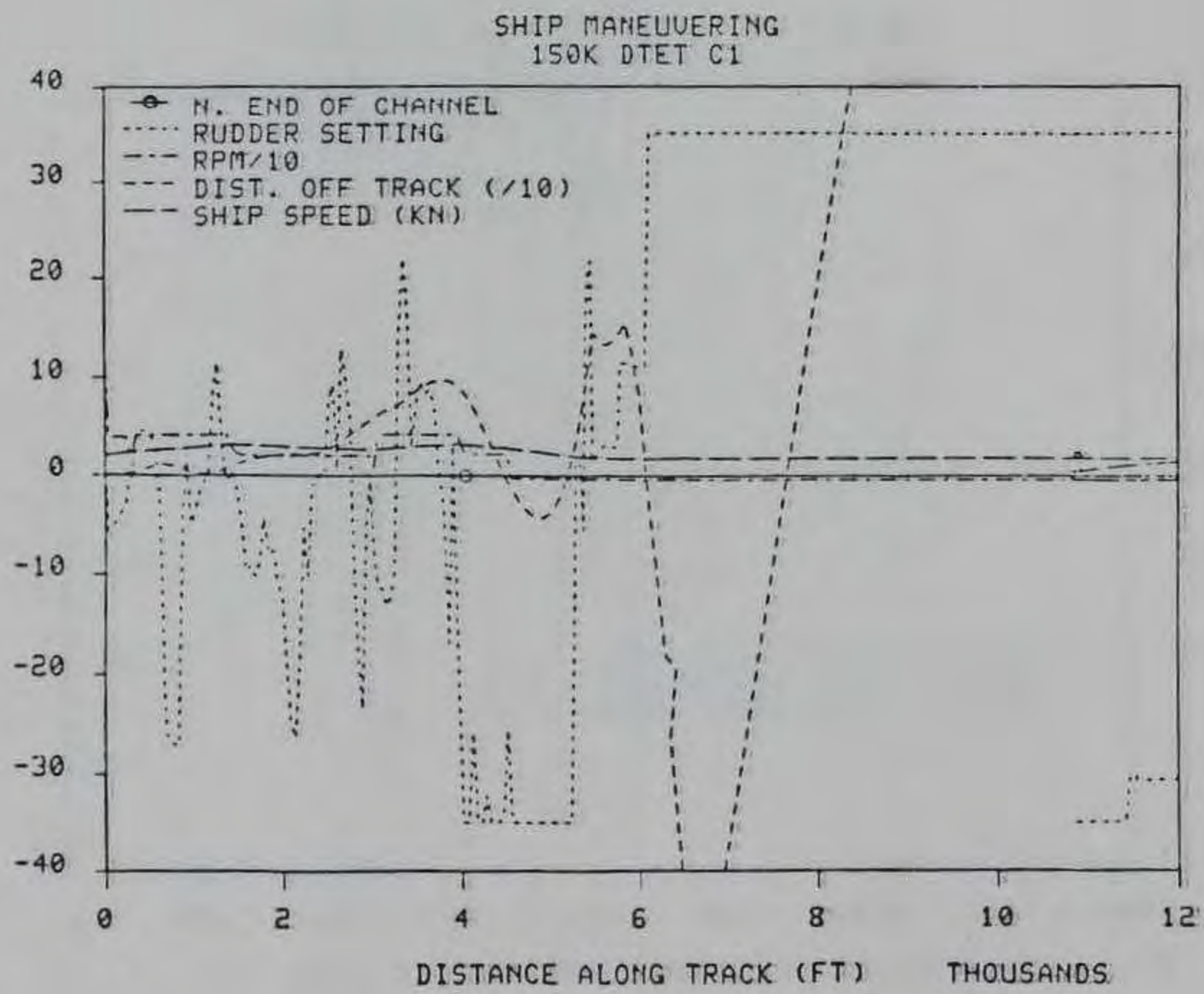
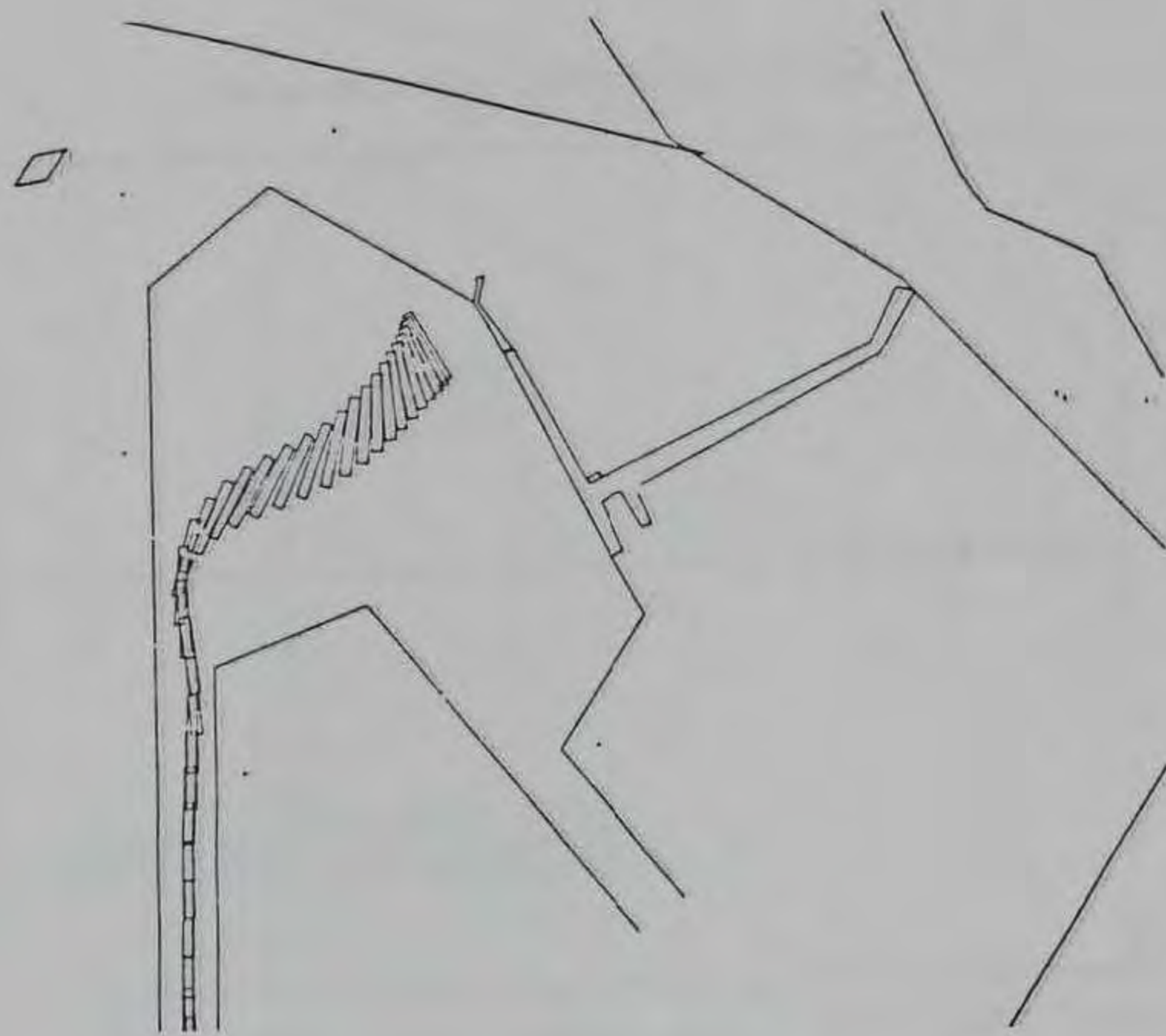

Figure A59. Ship maneuvering, 150K DTET C1

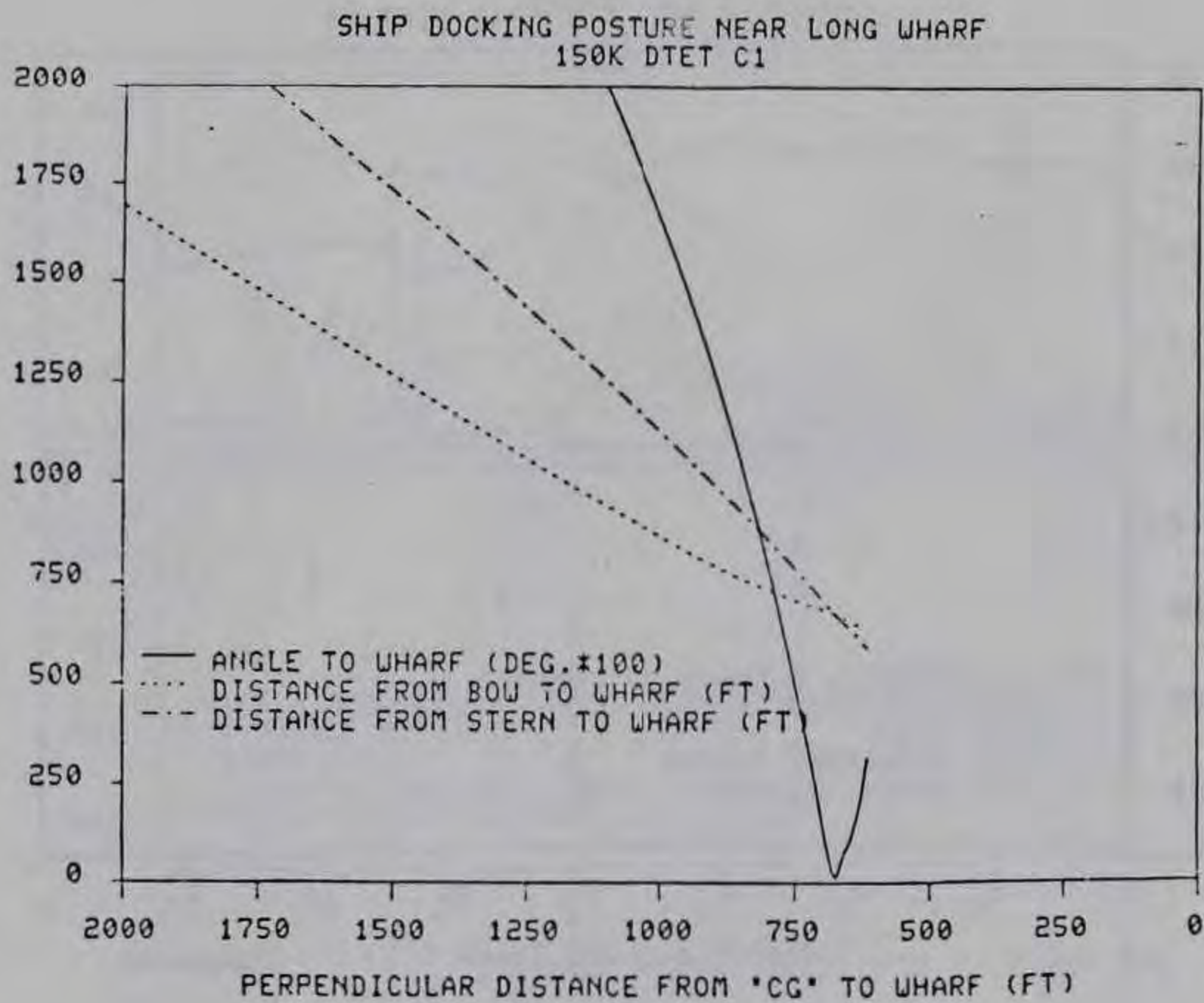
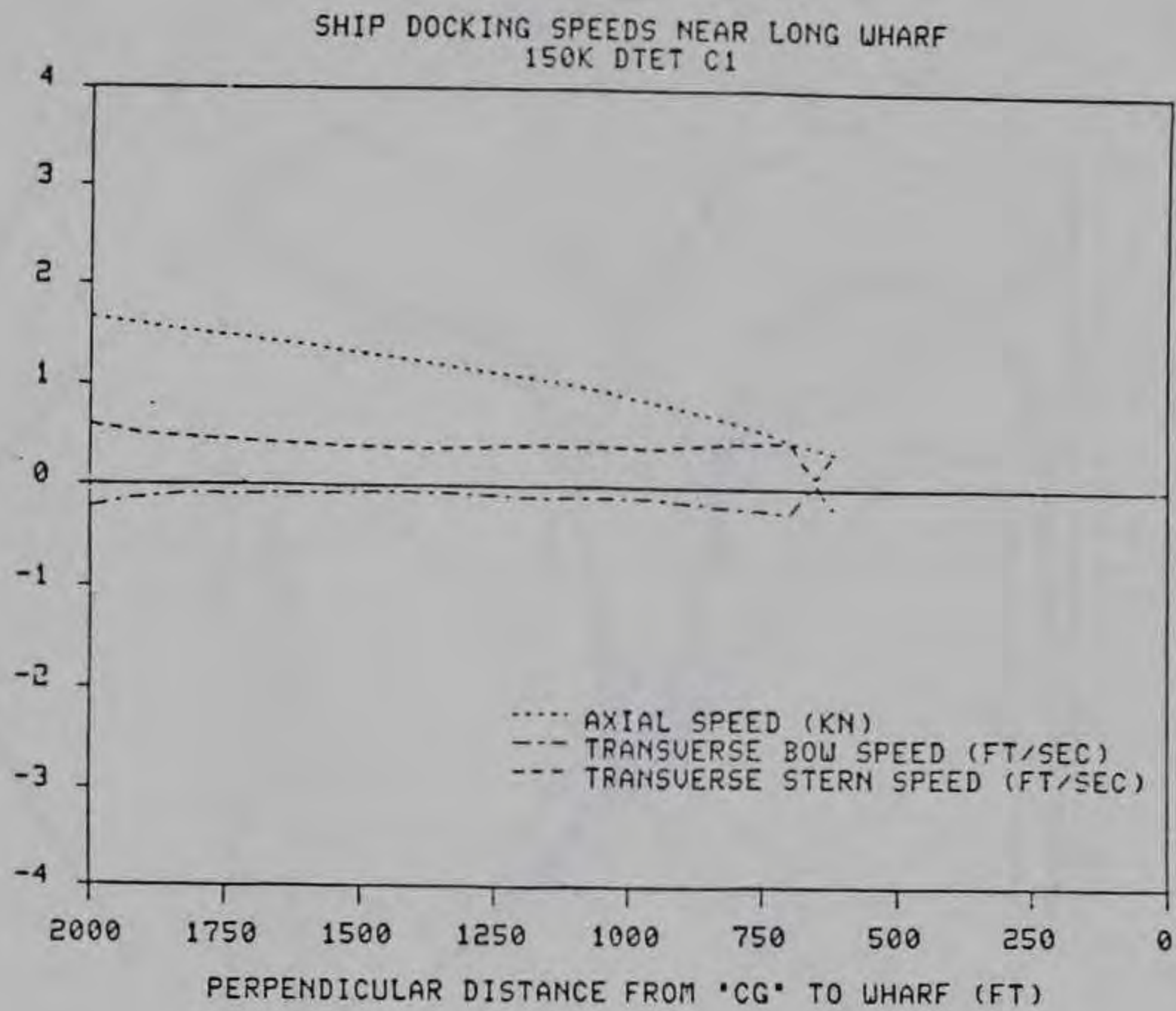
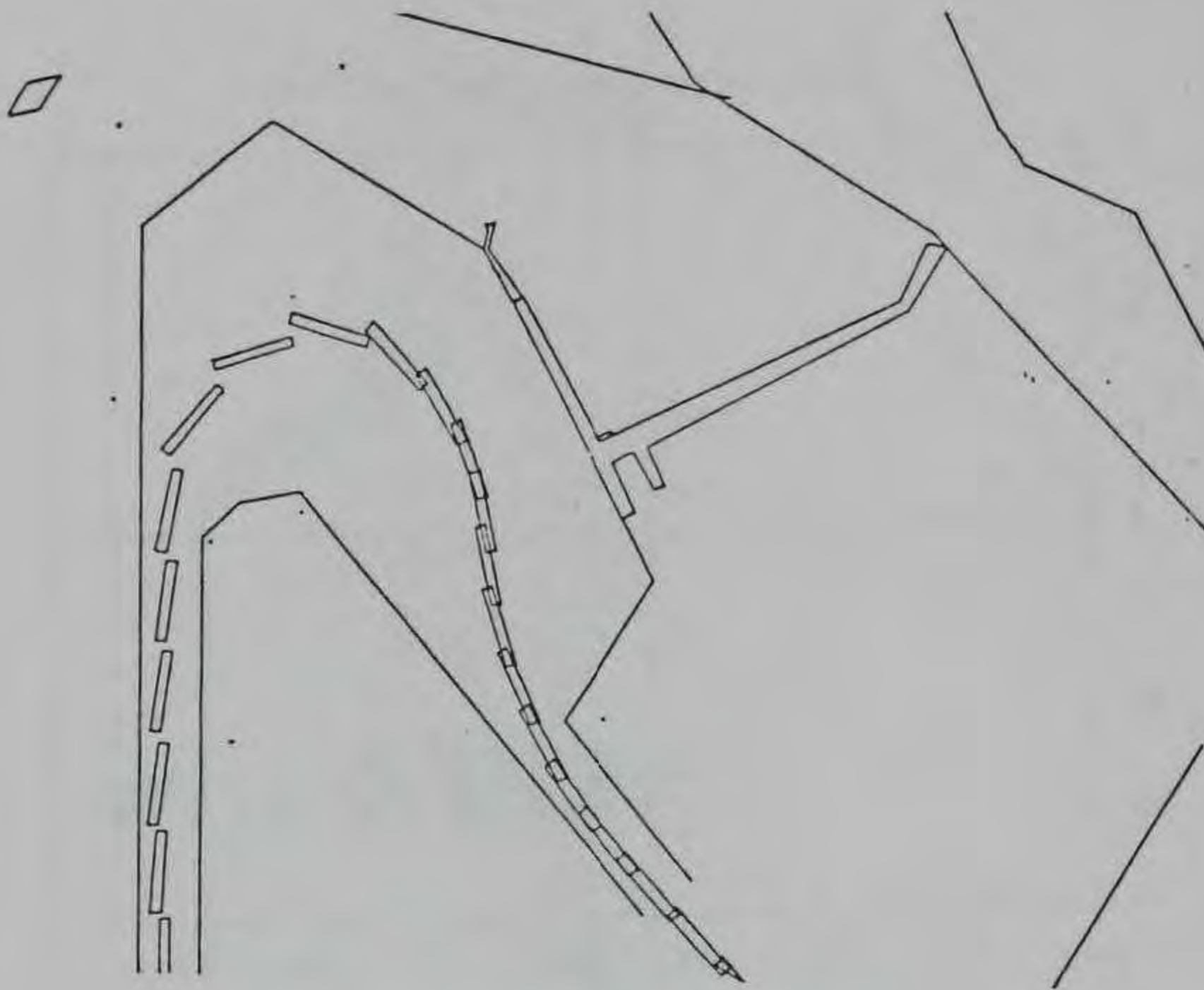

Figure A60. Ship docking speed and posture, 150K DTET C1



SHIP MANEUVERING
810 FT. CONTAINERSHIP BTFT A1

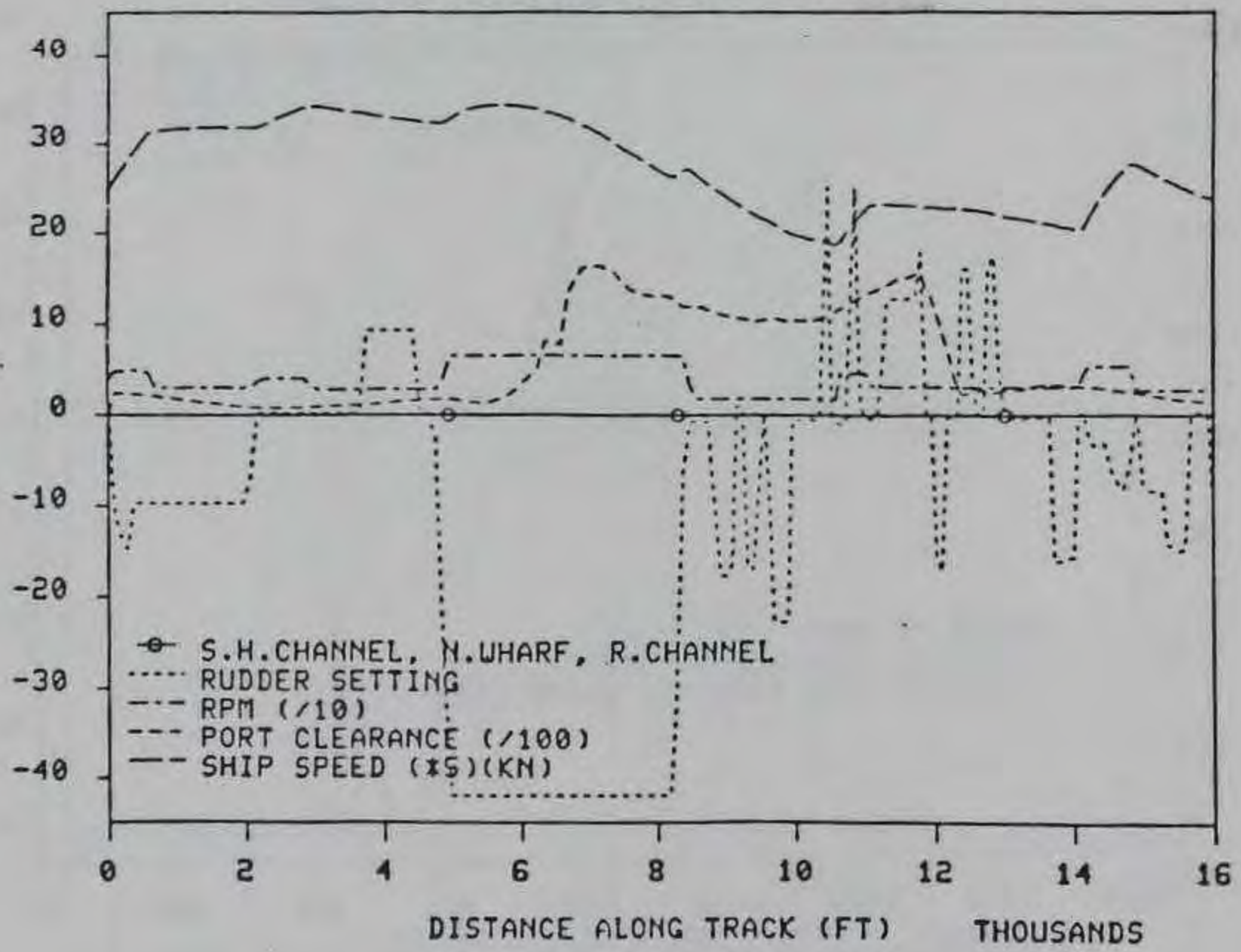

Figure A61. Ship maneuvering, 810-ft containership BTFT A1



SHIP MANEUVERING
810 FT. CONTAINERSHIP BTFT A2

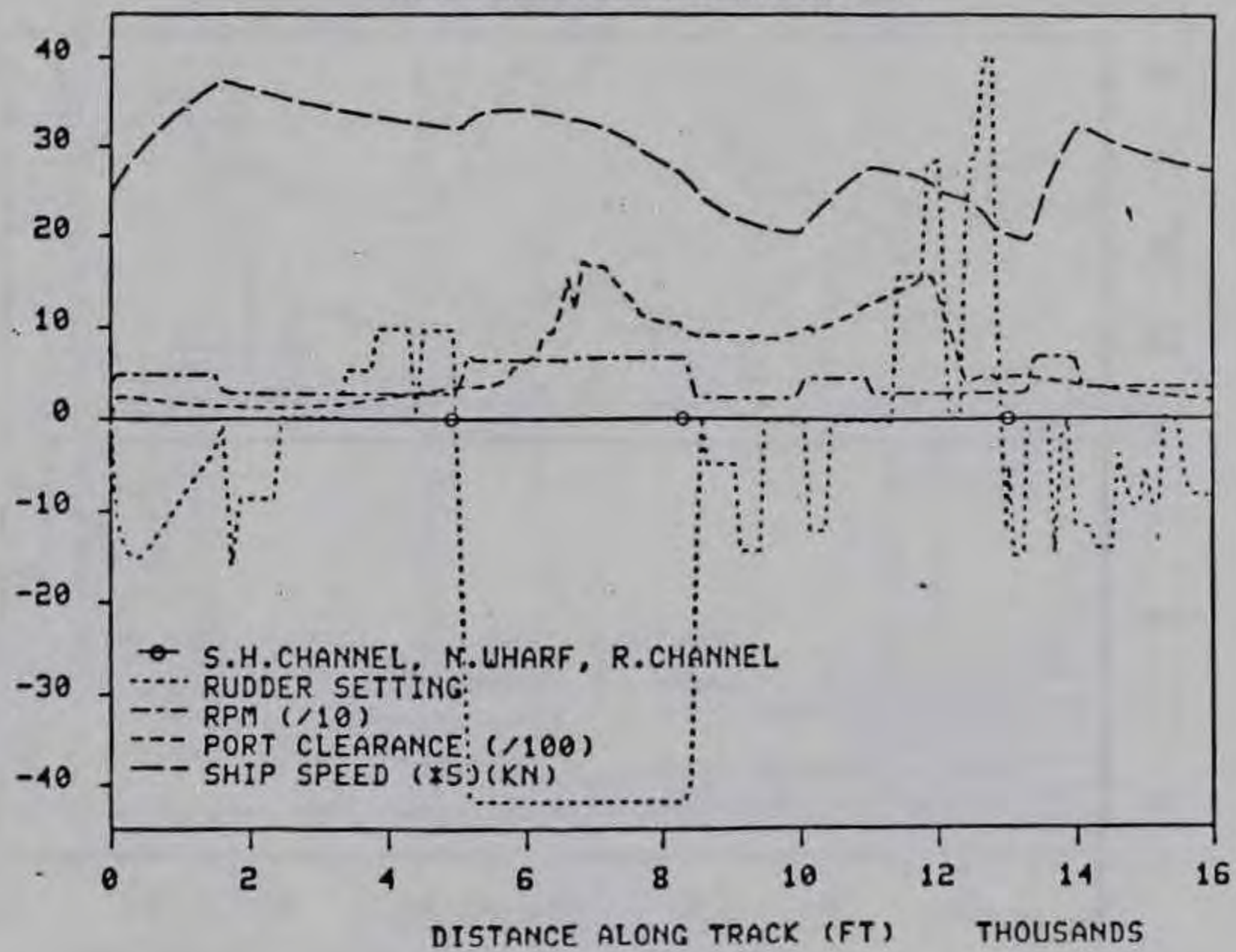
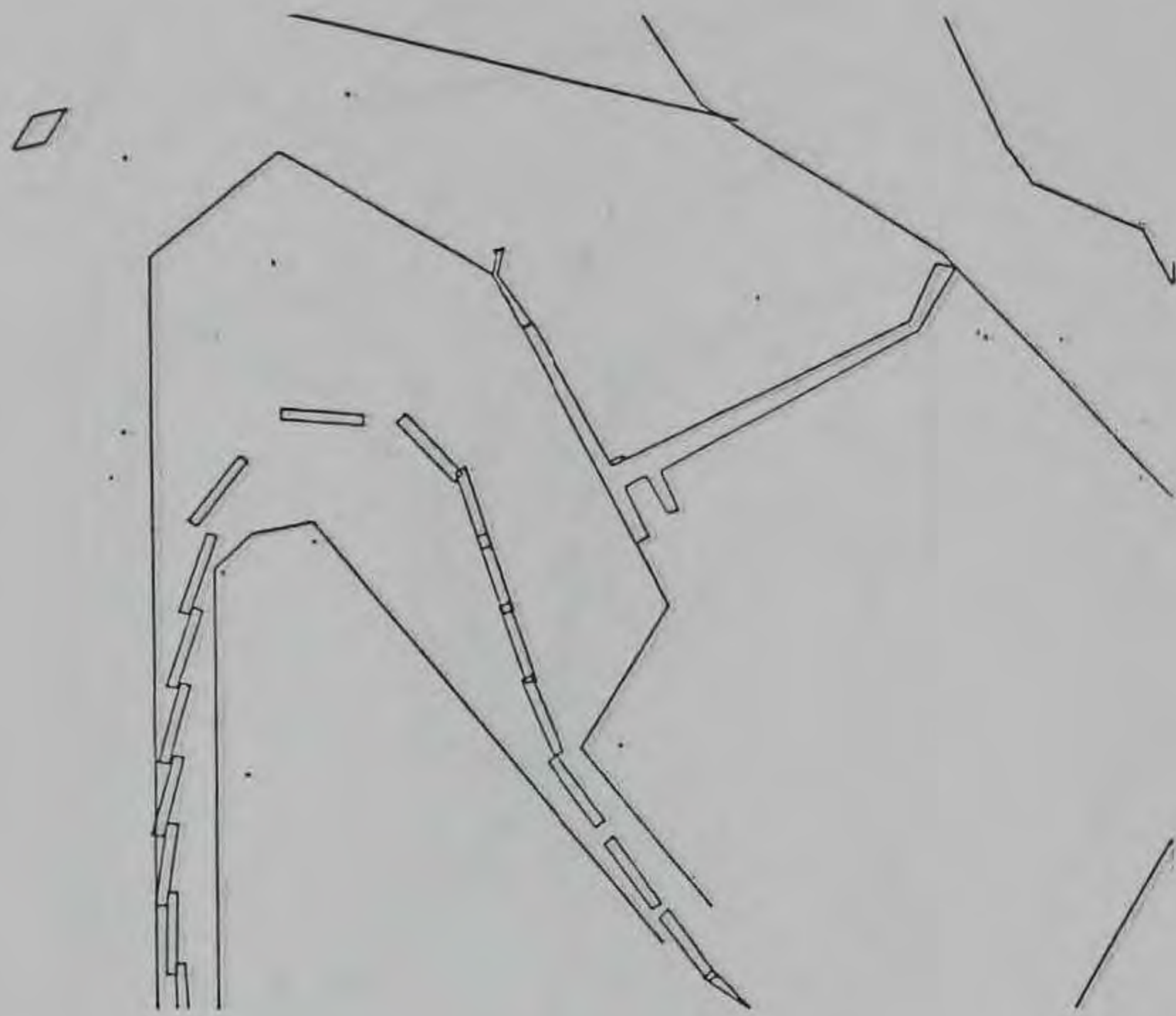

Figure A62. Ship maneuvering, 810-ft containership BTFT A2



SHIP MANEUVERING
810 FT. CONTAINERSHIP BTFT B1

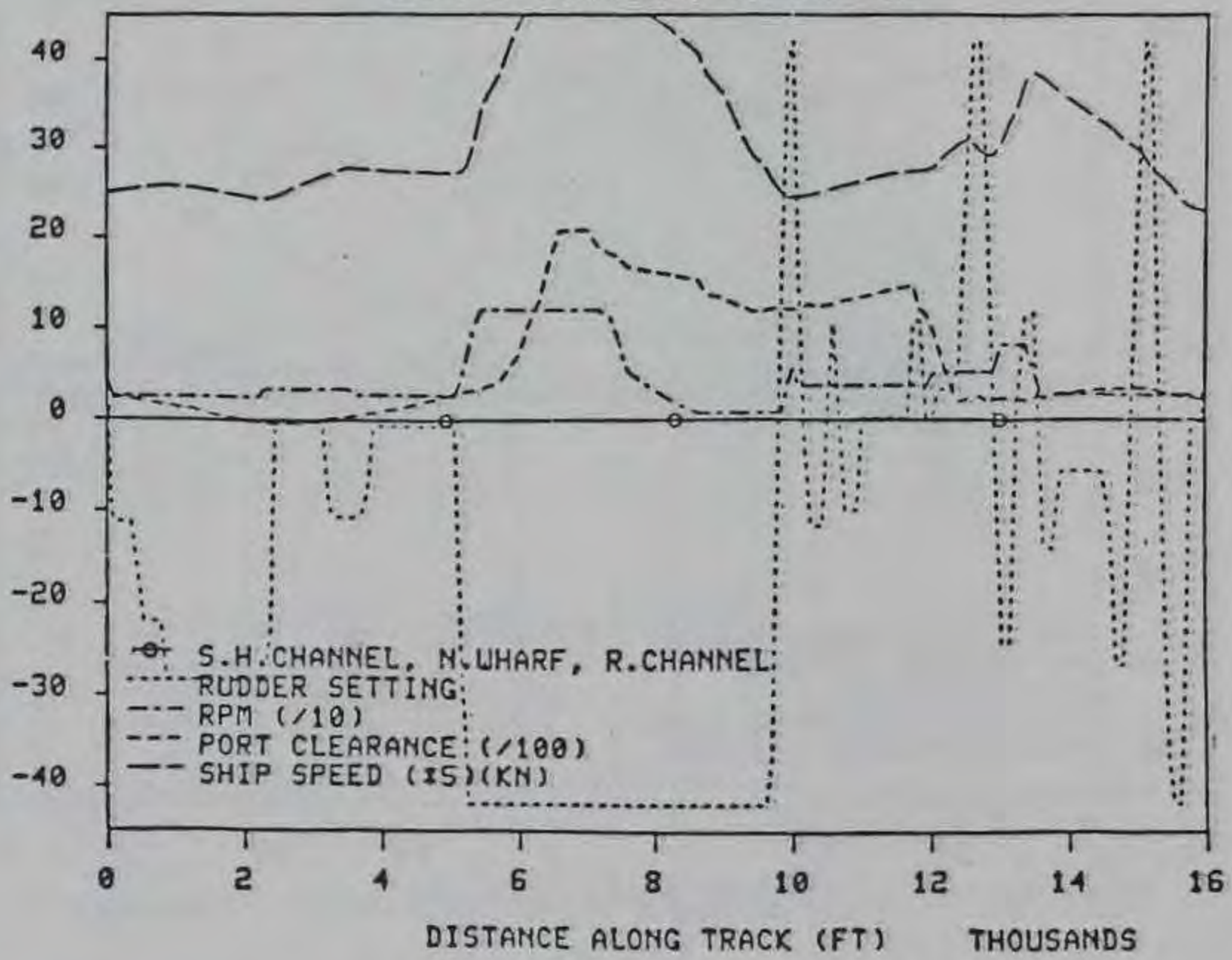
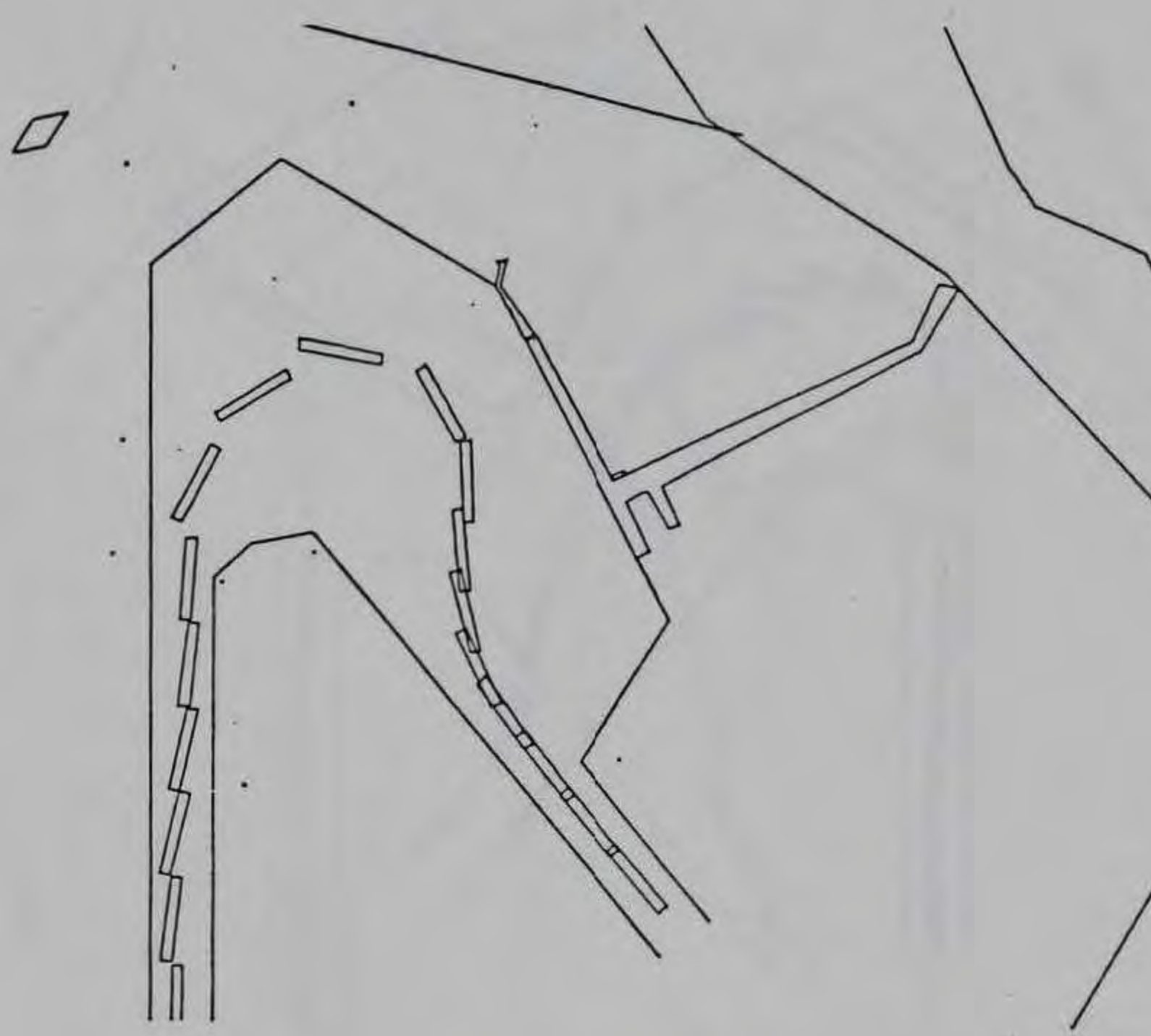

Figure A63. Ship maneuvering, 810-ft containership BTFT B1



SHIP MANEUVERING
810 FT. CONTAINERSHIP BTFT B2

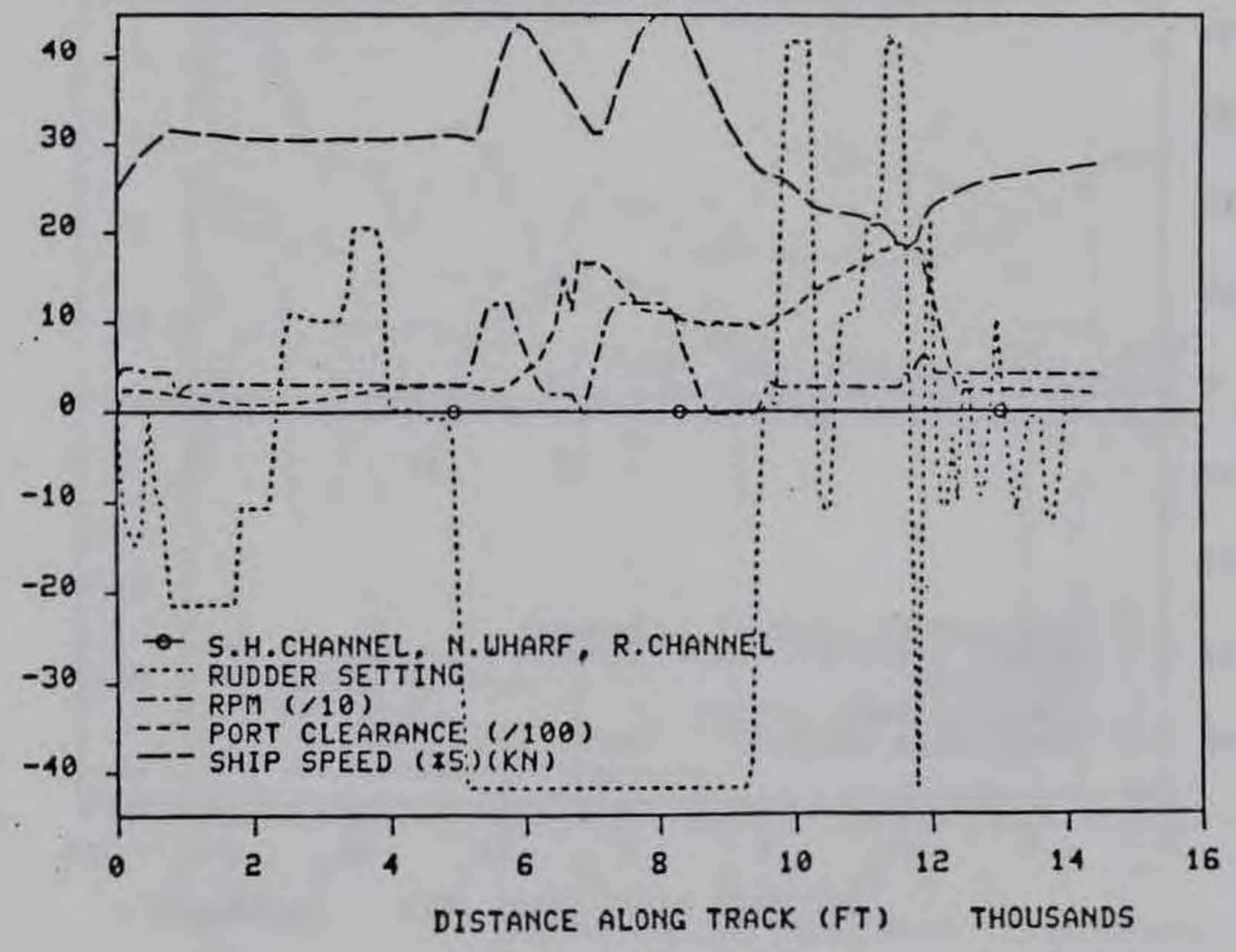
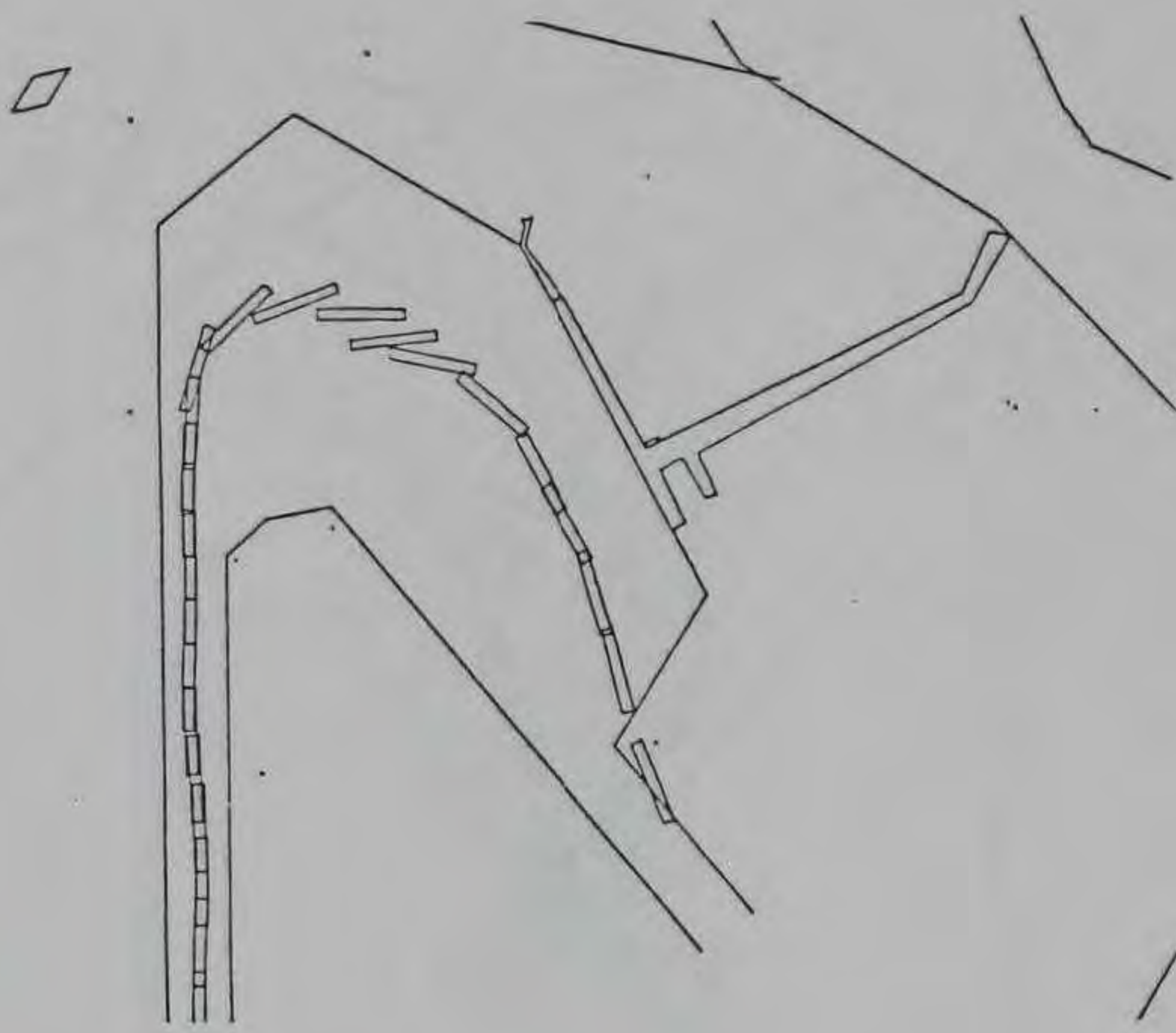

Figure A64. Ship maneuvering, 810-ft containership BTFT B2



SHIP MANEUVERING
810 FT. CONTAINERSHIP BTET A2

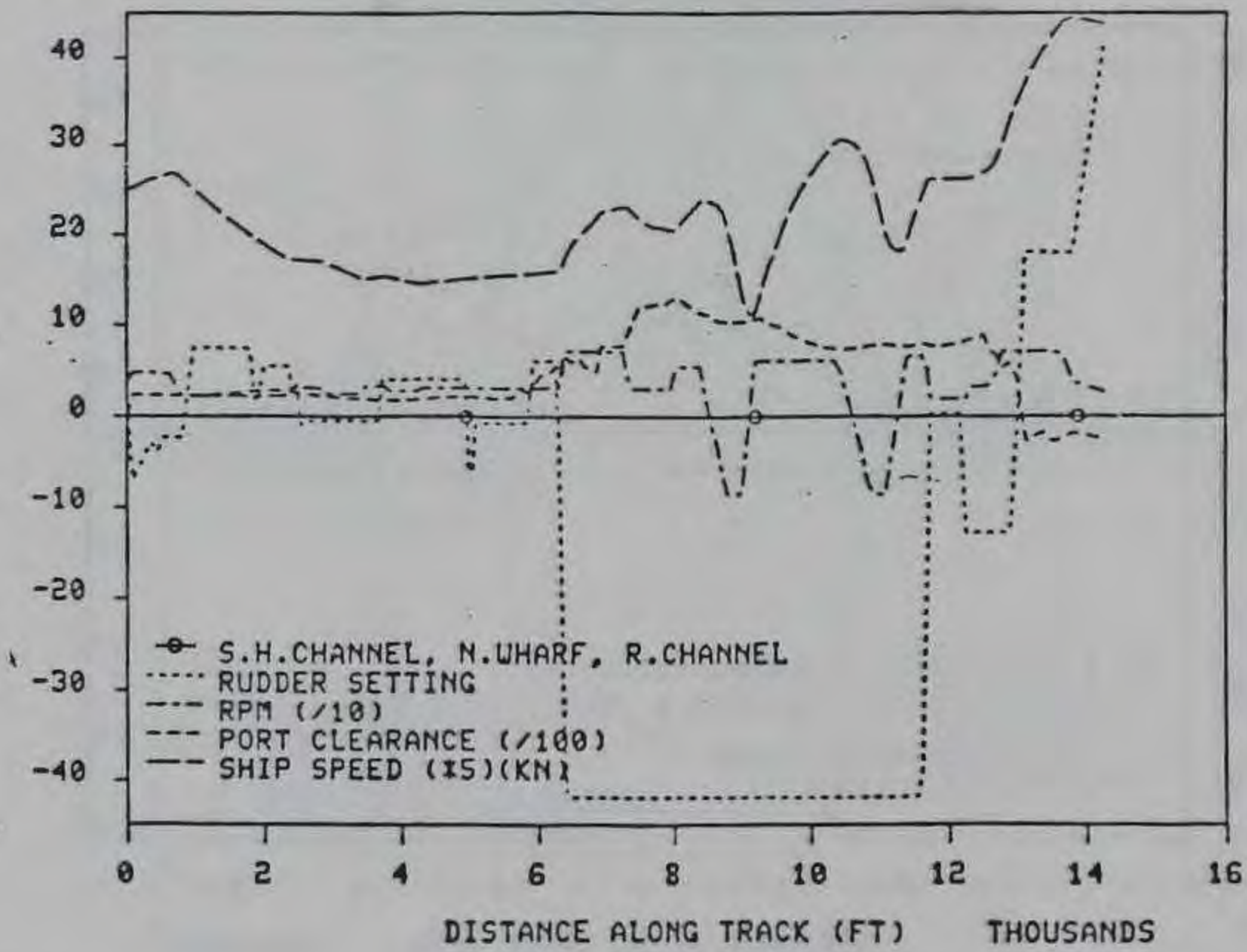
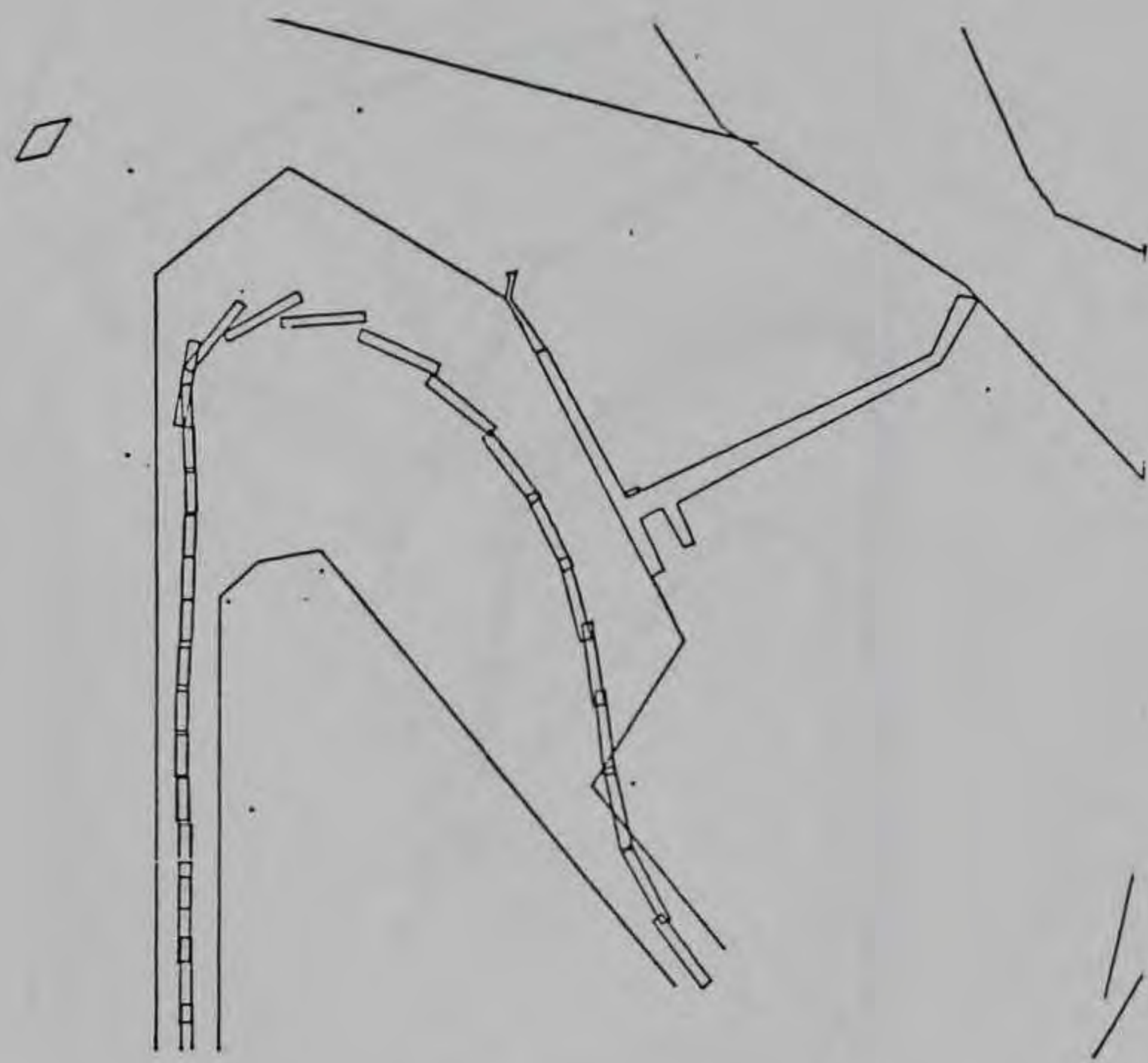

Figure A65. Ship maneuvering, 810-ft containership BTET A2



SHIP MANEUVERING
810 FT. CONTAINERSHIP BTET A3

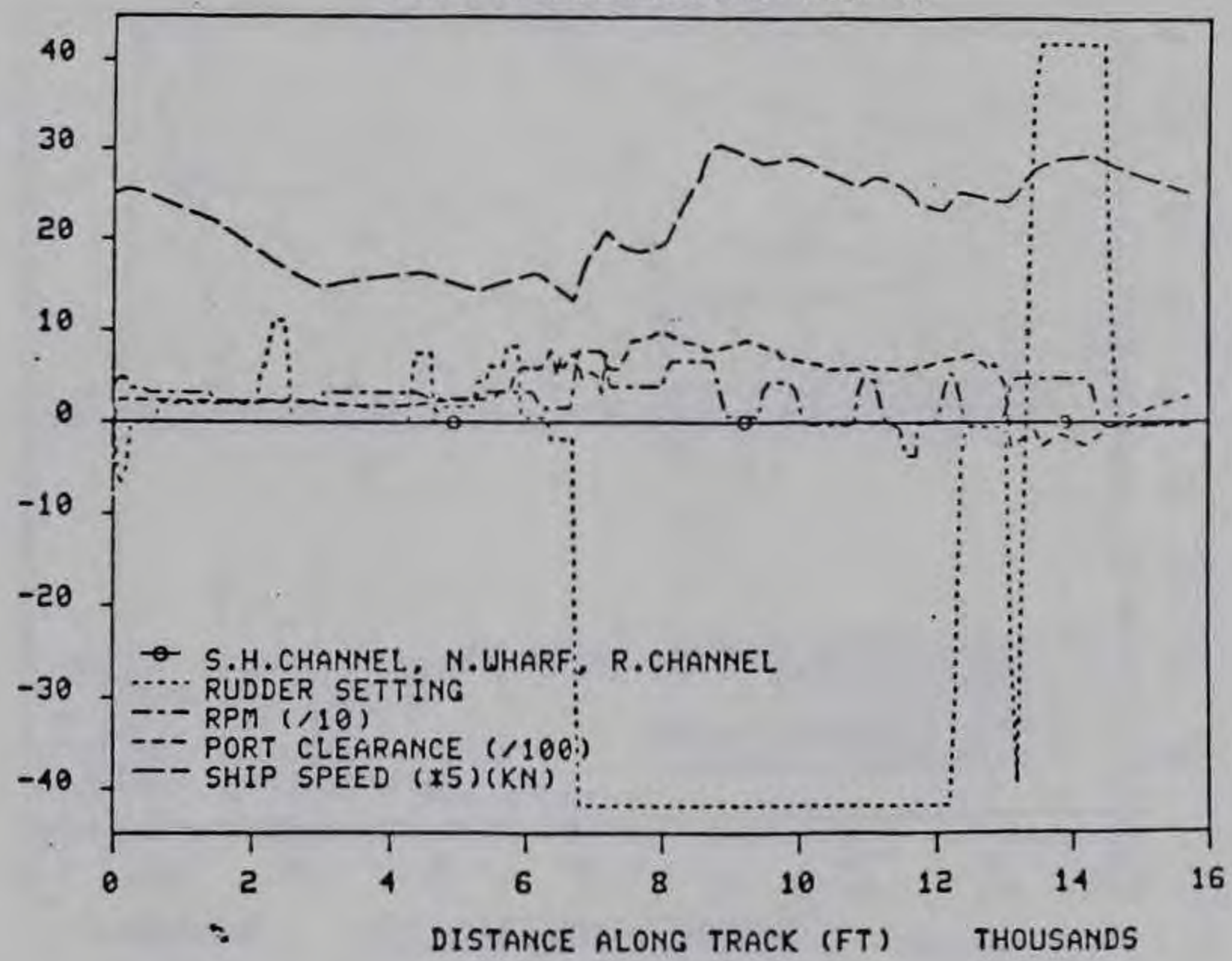
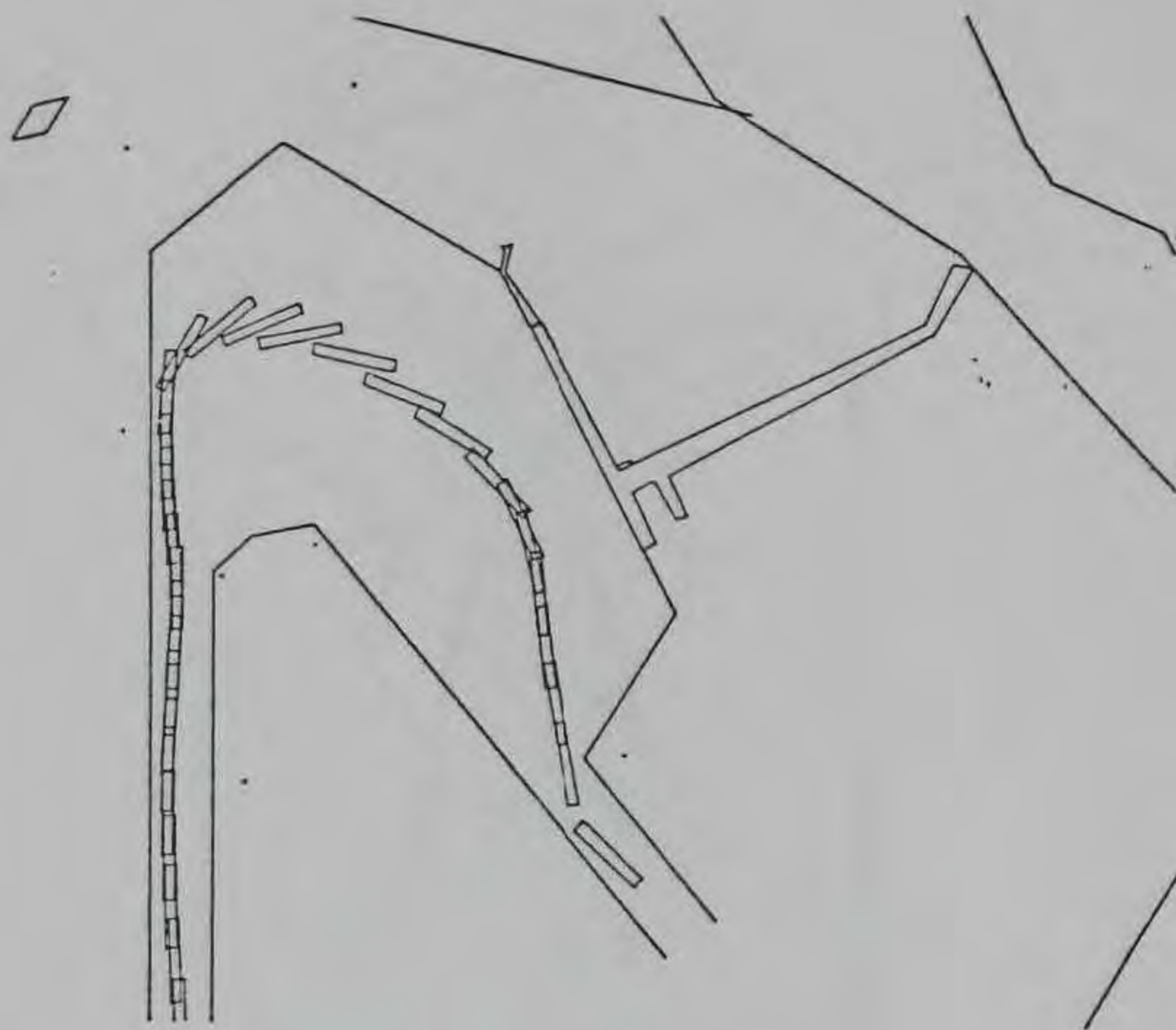

Figure A66. Ship maneuvering, 810-ft containership BTET A3



SHIP MANEUVERING
810 FT. CONTAINERSHIP BTET B2

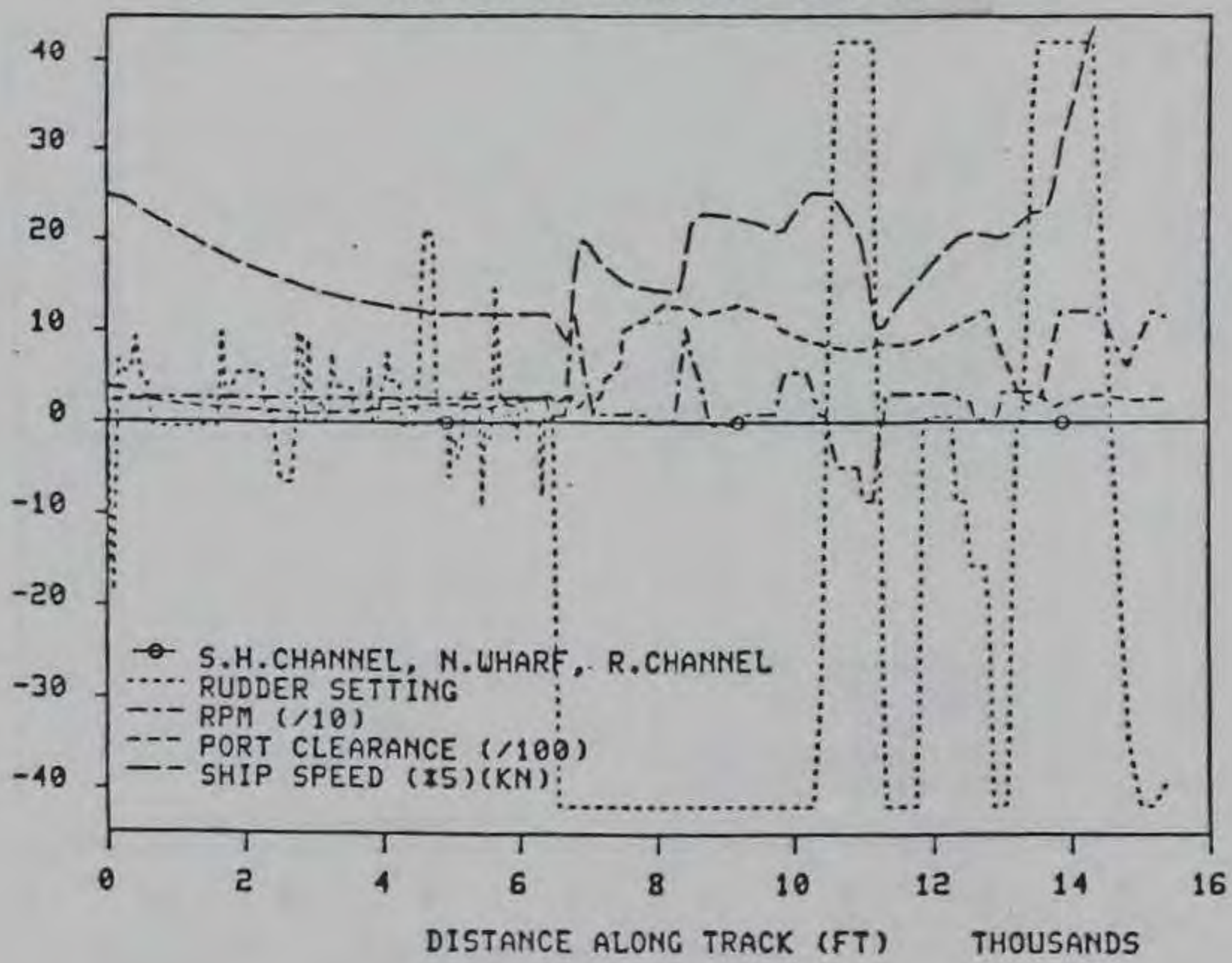

Figure A67. Ship maneuvering, 810-ft containership BTET B2

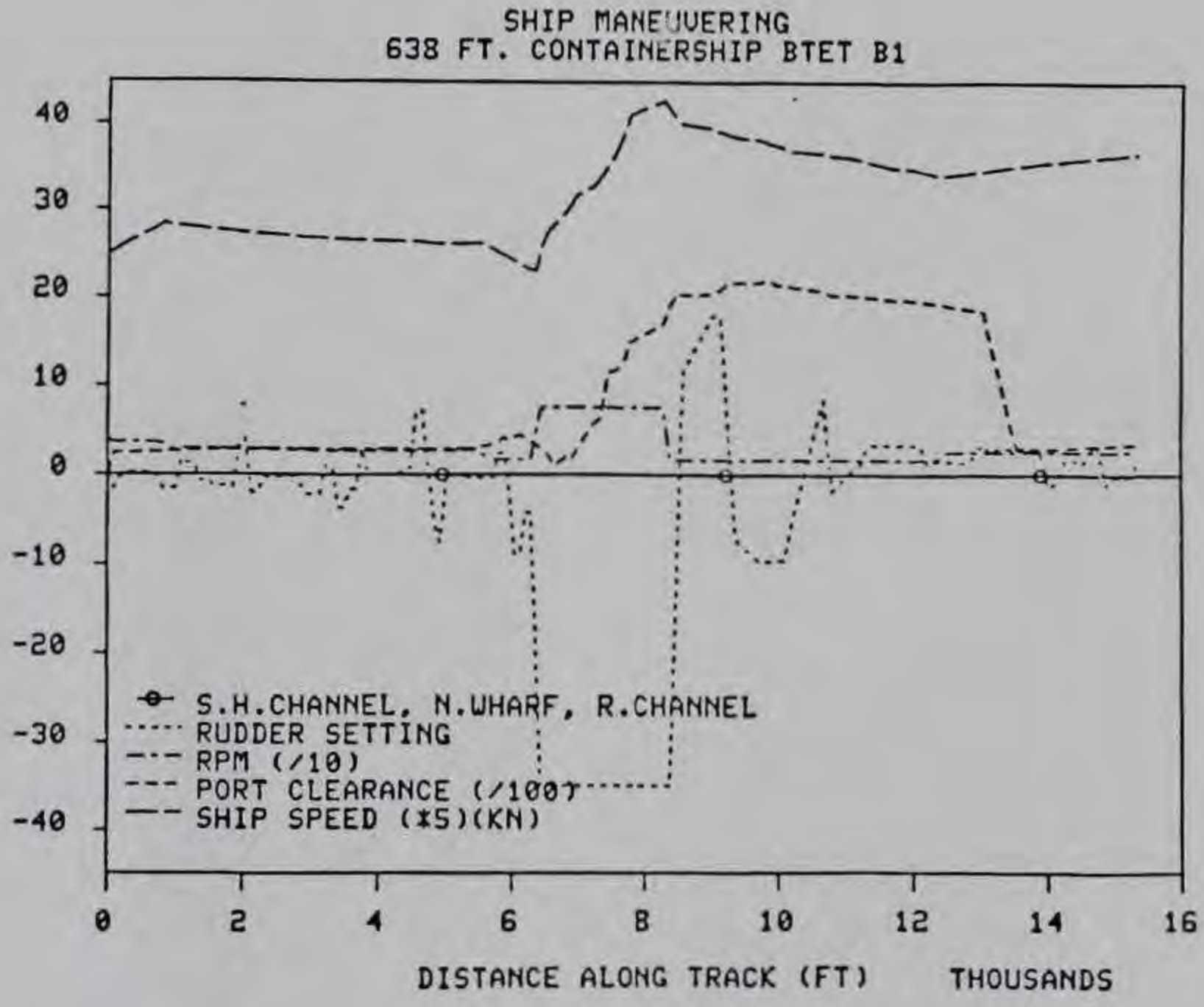
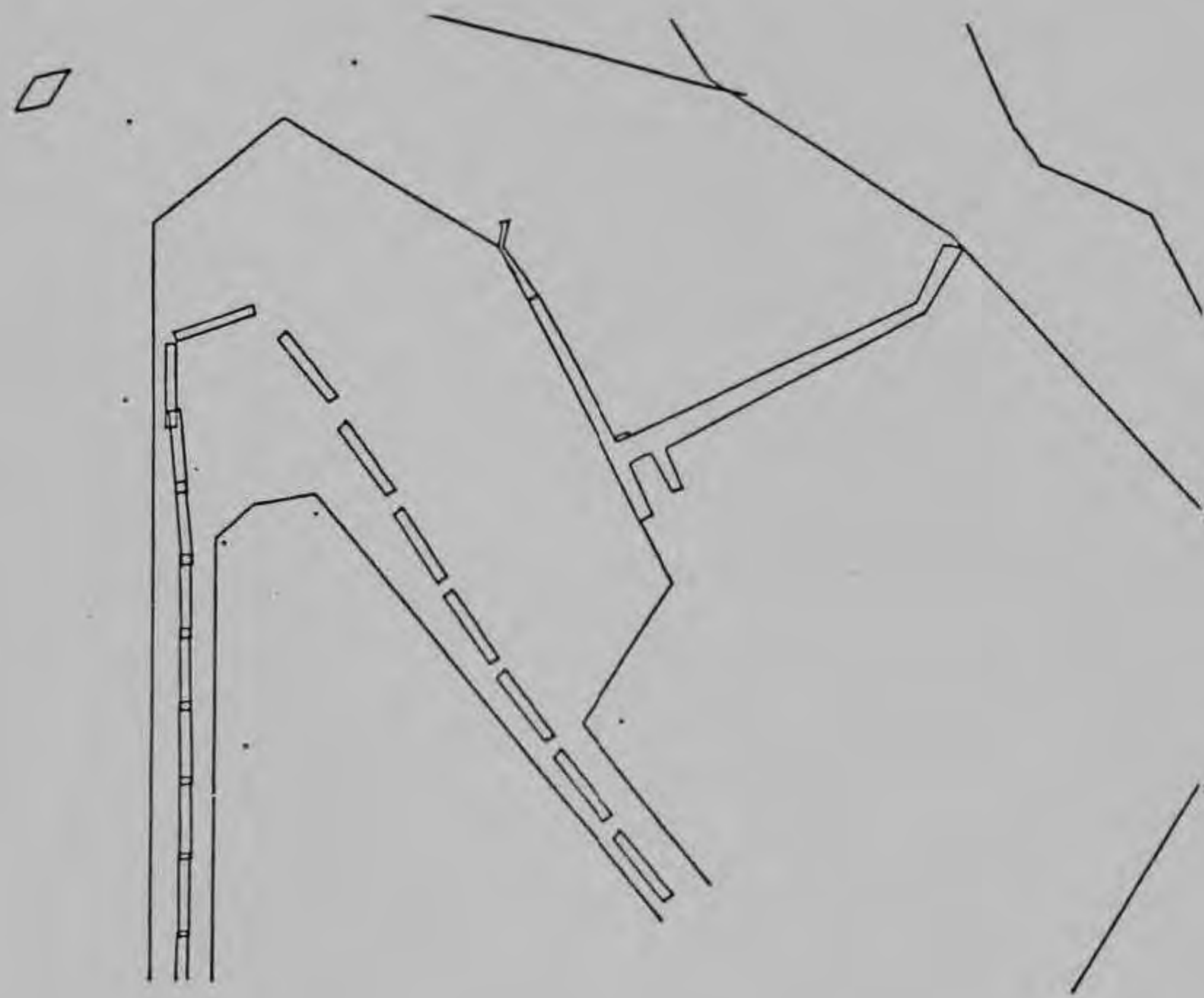

Figure A68. Ship maneuvering, 638-ft containership BTET B1