

Unclassified

SECURITY CLASSIFICATION OF THIS PAGE (When Data Entered)

REPORT DOCUMENTATION PAGE		READ INSTRUCTIONS BEFORE COMPLETING FORM
1. REPORT NUMBER Technical Report GL-79-7	2. GOVT ACCESSION NO.	3. RECIPIENT'S CATALOG NUMBER
4. TITLE (and Subtitle) ENGINEERING GEOLOGY AND GEOMORPHOLOGY OF STREAM-BANK EROSION; Report 3, THE APPLICATION OF WATER-BORNE GEOPHYSICAL TECHNIQUES IN FLUVIAL ENVIRONMENTS		5. TYPE OF REPORT & PERIOD COVERED Report 3 of a series
		6. PERFORMING ORG. REPORT NUMBER
7. AUTHOR(s) John R. May	8. CONTRACT OR GRANT NUMBER(s)	
9. PERFORMING ORGANIZATION NAME AND ADDRESS U. S. Army Engineer Waterways Experiment Station Geotechnical Laboratory P. O. Box 631, Vicksburg, Miss. 39180		10. PROGRAM ELEMENT, PROJECT, TASK AREA & WORK UNIT NUMBERS Section 32 Program, Task II, Work Unit 4
11. CONTROLLING OFFICE NAME AND ADDRESS Office, Chief of Engineers, U. S. Army Washington, D. C. 20314		12. REPORT DATE February 1982
		13. NUMBER OF PAGES 239
14. MONITORING AGENCY NAME & ADDRESS (if different from Controlling Office)		15. SECURITY CLASS. (of this report) Unclassified
		15a. DECLASSIFICATION/DOWNGRADING SCHEDULE
16. DISTRIBUTION STATEMENT (of this Report)  Approved for public release; distribution unlimited.		
17. DISTRIBUTION STATEMENT (of the abstract entered in Block 20, if different from Report)		
18. SUPPLEMENTARY NOTES  Available from the National Technical Information Service, 5285 Port Royal Road, Springfield, Va. 22151.		
19. KEY WORDS (Continue on reverse side if necessary and identify by block number)		
20. ABSTRACT (Continue on reverse side if necessary and identify by block number)  The development of waterborne geophysical systems and techniques has provided the geotechnical community with an array of data acquisition tools that can be applied to the fluvial environment. The major purpose of the study described in this report is to evaluate the performance, application, and capability of selected waterborne acoustic profiling systems for streambank erosion studies in fluvial environments. Additional objectives of the study reported  (Continued)		



## 20. ABSTRACT (Continued).

herein were to present types of available survey systems and related support equipment and to describe techniques for using the systems and equipment.

The principal types of acoustic survey systems discussed in this report are: (a) continuous seismic reflection profiling (CSR) systems, (b) side-scanning sonar systems, and (c) bathymetric profiling systems. Basic system components, i.e., sound sources, graphic recorders, hydrophones, transceivers, etc. are identified. The operational principles and characteristics of system components are discussed. System limitations and environmental constraints, i.e., frequency, resolution, water depths, weather, bottom and subbottom composition, porosity and density of sediments, etc., are described. Support equipment requirements for conducting waterborne geophysical surveys, i.e., survey boats, positioning equipment, bathymetric profiling systems, and sampling equipment, are also included. Personnel requirements, selection of survey systems, collection and use of background and historical information, and suggested operation and towing techniques for waterborne geophysical systems are additional topics discussed in the report.

Several study areas were selected for the employment and evaluation of waterborne geophysical systems. The study areas were located on the White River, Lower and Middle Mississippi River, Missouri River, and the Ohio River. The physiographic, geologic, and hydrologic characteristics of the study areas and associated survey sites were integrated with the results of the surveys. The data collected at the survey sites included that from CSR, side-scanning sonar, and bathymetric systems and are presented herein.

The application of CSR and side-scanning sonar systems at the survey sites revealed that the state of the art of these systems is sufficiently developed for application to streambank erosion studies, as well as other engineering, geologic, hydrologic, and hydraulic investigations in the fluvial environment. The CSR technique provides a capability for the detection and identification of stratigraphic and structural geology, and to a lesser extent, lithologic features on and below the channel bottom. CSR systems were determined to be particularly useful for locating bedrock below the channel bottom. Overall channel bottom characteristics can be determined by side-scanning sonar. The side-scanning sonar system detects natural features, i.e., sand waves, rock outcrops, scour holes, and subaqueous bank failures. Man-made features such as sunken boats and barges, pipelines, revetments, and miscellaneous debris are also detectable by side-scanning sonar systems.

CSR and side-scanning sonar systems can be most successfully applied for periodic routine or special purpose monitoring. The bottom and subbottom data acquired for each period, or survey, can be compared and changes or trends in channel conditions can be identified. Acoustic profiling surveys can be particularly significant where streambank erosion, subaqueous bank failures, or other adverse fluvial conditions are persistently active or have been intermittently active historically.



## PREFACE

This report is the third of a series dealing with the engineering geology and geomorphology of streambank erosion. The study was conducted in the Geotechnical Laboratory (GL) of the U. S. Army Engineer Waterways Experiment Station (WES) and was funded by the Office, Chief of Engineers (OCE), U. S. Army by authority of the Section 32 Program, "Streambank Erosion Control, Evaluation, and Demonstration Act of 1974." The investigation described within this report was a part of Task II, "The Influences of Fluvial Geology on Streambank Erosion," which was a part of Work Unit 4, "Research on Soil Stability and Identification of Causes of Bank Erosion," of the Program.

The investigation was performed during the period March 1977 to January 1980 under the general supervision of Mr. J. P. Sale, former Chief, GL; Dr. W. F. Marcuson III, Chief, GL; Dr. Paul Hadala, Assistant Chief, GL; Dr. D. C. Banks, Chief, Engineering Geology and Rock Mechanics Division (EG&RMD); Mr. J. H. Shamburger, Chief, Engineering Geology Applications Group (EGAG); and Mr. C. L. McAnear, Chief, Soil Mechanics Division, and Principal Investigator, Work Unit 4. All phases of the study were under the direct supervision of Dr. D. M. Patrick, EG&RMD, the Principal Investigator of Task II.

Field surveys and data collection were accomplished by Messrs. J. R. May, W. L. Murphy, and D. M. Hyman, EGAG; R. C. Gunkel, Pavement Systems Division; and D. A. Johnson, Rock Mechanics Applications Group. The assimilation and analysis of the acoustic survey data collected in the field were performed by Messrs. May and Murphy. This report was written by Mr. May, with the exception of those portions of the report concerning the physiographic, geologic, and survey operational conditions located in the Ohio River study area, which were written by Mr. Murphy.

Because of the scope and nature of this study, the author is indebted to a large number of individuals and organizations which provided generously of their time and knowledge to the conduct of the study. Regretfully, it would be difficult to acknowledge all of these personnel and organizational components. However, the author is particularly

appreciative of the assistance extended to him by the following individuals and organizations: Messrs G. P. Bonner, G. C. Downing, B. E. Warnock, and J. A. Forbes, Instrumentation Services Division, WES; Mr. D. E. Abert, Ocean Seismic Electronics, Inc., Houston, Tex.; Mr. James McQuay, Marine Technical Services, Inc., Houston, Tex.; Mr. Thomas Harmon; Mr. Roger Caron, EG&G, Inc., Waltham, Mass.; Ocean Research and Equipment, Inc., Falmouth, Mass.; Klein Associates, Inc., Salem, N. H.; Harvey-Lynch, Inc., Houston, Tex.; Mr. Mike Stewart, EPC Labs, Inc., Beverly, Mass.; Messrs. A. L. Wilkerson, M. F. Barton, D. R. Kilore, and C. R. Fisher, Memphis Engineer District, Corps of Engineers (CE); Mr. J. O. Smith, Smith Towing Company, Inc., Vicksburg, Miss.; Messrs. E. L. Howe and B. R. Winkley, Vicksburg Engineer District, CE; Messrs. D. D. Huston, C. L. Turlin, and F. E. Brumfield, St. Louis Engineer District, CE; Messrs. W. J. Mellema, T. Niday, and R. Witty, Missouri River Division, CE; Messrs. H. E. Christian and K. H. Murnan, Omaha Engineer District, CE; and Messrs. R. Beringer, R. Neill, and J. Roselli, Pittsburgh Engineer District, CE.

The Commanders and Directors of the WES during the conduct of the study and the preparation of this report were COL John L. Cannon, CE, COL Nelson P. Conover, CE, and COL Tilford C. Creel, CE. The Technical Director was Mr. Fred R. Brown.



## CONTENTS

	<u>Page</u>
PREFACE . . . . .	1
CONVERSION FACTORS, U. S. CUSTOMARY TO METRIC (SI)	
UNITS OF MEASUREMENT . . . . .	4
PART I: INTRODUCTION . . . . .	5
Background . . . . .	5
Purpose . . . . .	6
Scope . . . . .	7
PART II: WATERBORNE ACOUSTIC PROFILING SYSTEMS . . . . .	8
Basic System Components . . . . .	12
System Limitations . . . . .	27
Environmental Limitations . . . . .	29
Bottom and Subbottom Parameters Affecting the Profiling Method . . . . .	35
Acoustic Profiling Support Requirements . . . . .	38
PART III: PLANNING AND CONDUCTING ACOUSTIC SURVEYS . . . . .	63
Selection of Acoustic Profiling Systems . . . . .	63
Collection and Use of Background Data . . . . .	64
Presurvey Planning . . . . .	68
Implementation of the Survey . . . . .	74
Deployment and Operation of Acoustic Profiling Systems . . . . .	76
PART IV: DATA COLLECTION AND ANALYSIS . . . . .	88
Description of Selected Geophysical Systems . . . . .	88
Selection of Study Areas . . . . .	96
Data Interpretation Procedures . . . . .	98
Presentation of Selected Acoustic Survey Data . . . . .	102
White River Survey Sites . . . . .	103
Lower Mississippi River Survey Sites . . . . .	123
Middle Mississippi River Survey Area . . . . .	149
Missouri River Survey Sites . . . . .	175
Ohio River Survey Sites . . . . .	197
PART V: CONCLUSIONS AND RECOMMENDATIONS . . . . .	232
Conclusions . . . . .	232
Recommendations . . . . .	234
REFERENCES . . . . .	235
BIBLIOGRAPHY . . . . .	237



CONVERSION FACTORS, U. S. CUSTOMARY TO METRIC (SI)  
UNITS OF MEASUREMENT

U. S. customary units of measurement used in this report can be converted to metric (SI) units as follows:

<u>Multiply</u>	<u>By</u>	<u>To Obtain</u>
cubic inches	16.38706	cubic centimetres
Fahrenheit degrees	5/9	Celsius degrees or Kelvins*
feet	0.3048	metres
inches	2.54	centimetres
knots (international)	0.5144444	metres per second
miles (U. S. statute)	1.609347	kilometres
pounds (mass)	0.45359237	kilograms

---

\* To obtain Celsius (C) temperature readings from Fahrenheit (F) readings, use the following formula:  $C = (5/9)(F - 32)$ . To obtain Kelvin (K) readings, use:  $K = (5/9)(F - 32) + 273.15$ .



ENGINEERING GEOLOGY AND GEOMORPHOLOGY  
OF STREAMBANK EROSION

THE APPLICATION OF WATERBORNE GEOPHYSICAL  
TECHNIQUES IN FLUVIAL ENVIRONMENTS

PART I: INTRODUCTION

Background

1. Streambank erosion represents a chronic, widespread problem in the United States. Although erosional processes are a natural part of the stream regimen, man has often altered and accelerated the natural erosional efficiency of streams. This has been accomplished through the application of a host of land-use and engineering practices. A study conducted in the late 1960's estimated that of 3.5 million miles\* of streams in the United States (7 million bank-miles) approximately 8 percent or 549,000 bank-miles were experiencing varying levels of bank erosion (Office, Chief of Engineers 1969). In 1974, the Congress authorized the U. S. Army Corps of Engineers to conduct a comprehensive study--the Streambank Erosion Control Evaluation and Demonstration Act of 1974 (Section 32 Program) to determine the cause, effect, and control of streambank erosion.

2. A significant part of the research conducted by the Corps of Engineers at the U. S. Army Engineer Waterways Experiment Station (WES) in support of the Section 32 Program was to determine the role that geologic, geomorphologic, and environmental conditions had in streambank erosion processes (Smith and Patrick 1979, Whitten and Patrick 1981). The subaerial natural processes that occur within and adjacent to fluvial stream channels can generally be monitored and documented by a variety of proven methods, i.e., ground and aerial surveys. However,

---

\* A table of factors for converting U. S. customary units of measurement to metric (SI) units is presented on page 4.



those processes occurring within the subaqueous and subsurface areas of stream channels are more difficult to detect and monitor. The development of waterborne acoustical profiling equipment and instrumentation has provided the geotechnical community with an excellent array of data collection tools that can be applied to aquatic environments. The most frequently utilized of these tools are continuous seismic reflection profiling (CSRP) and side-scanning sonar systems. The CSRP system is designed specifically for the acquisition of subsurface lithological and geological data. The side-scanning sonar system is utilized for the detection and identification of natural and man-made features located on the bottom of water bodies. Literally hundreds of CSRP and side-scanning sonar systems are in widespread use throughout the world at the present time. Most of these systems are employed in support of petroleum exploration, oceanographic research, and engineering projects in nearshore and offshore marine environments. Because of the significant technological advances made in the field of waterborne sensor hardware and technique, and because of the current emphasis on environmental and ecological controls, CSRP systems have almost entirely replaced subaqueous seismic reflection operations using explosives.

3. The exclusion of explosives as the primary energy source in waterborne geophysical surveying and the adoption of the CSRP system have led to the expansion of surveying into inland waterways and lakes. Task II (Influence of Geology and Geomorphology on Streambank Erosion) of Work Unit 4 (Research on Soil Stability and Identification of Causes of Streambank Erosion), Section 32 Program, provided an excellent opportunity for WES to apply CSRP and side-scanning sonar systems and techniques to fluvial environments in support of the streambank erosion study and to demonstrate their usefulness in these environments.

#### Purpose

4. The principal purpose of this study was to evaluate and describe the performance and applicability of selected CSRP and side-scanning sonar systems to locate, identify, and monitor significant



geological, morphological, and man-made features or processes occurring in stream channels that are directly or indirectly involved in the process of streambank erosion. An additional objective of the study was to present types of equipment available and techniques of employing the equipment that can assist in various phases of engineering and geological studies located within fluvial environments.

### Scope

5. The major emphasis of this study was to determine the applicability of selected waterborne acoustic profiling systems at sites along streams where streambank erosion has been a recurrent problem. This report presents data obtained during waterborne surveys conducted on selected reaches of the Mississippi, Ohio, Missouri, and White Rivers. The data consists primarily of subsurface CSRP and side-scanning sonar profile records which provide graphic illustrations of the capabilities of these systems to detect and monitor riverine features and processes. Data from published sources, field observations, and individuals engaged in the manufacture of acoustic profiling equipment concerning the type, operational characteristics, availability, and limitations of waterborne sensors are presented herein. In addition, procedures, techniques, and methodologies for optimum deployment of waterborne sensors and data interpretation are also presented in this report.



## PART II: WATERBORNE ACOUSTIC PROFILING SYSTEMS

6. The major types of acoustic profiling systems that were utilized during this investigation and that will be discussed in this report are: (a) CSRP systems, (b) side-scanning sonar systems, and (c) bathymetric profiling systems. The geophysical technique was originally developed for terrestrial exploration for mineral resources and consequently adapted to offshore marine exploration (U. S. Army Engineer Waterways Experiment Station 1980). Acoustic profiling systems currently in use had their beginnings in World War I when the British Royal Navy attempted to develop acoustic listening devices for the detection of German submarines. These early devices, popularly known as ASDIC systems (ASDIC was an acronym for the Antisubmarine Detection Investigation Committee which was charged with the development of methodology to counteract the German submarine threat) resulted in some measure of success, providing impetus for further research in underwater acoustics. Further improvement took place during World War II, when the word sonar (Sound Navigation and Ranging) replaced ASDIC to describe the methodology or equipment for determining by underwater sound the presence, location, or nature of objects in the sea (Stephens 1970).

7. The interest in the potential use of acoustics for subsurface exploration expanded rapidly after World War II. About 1954 the first equipment designed specifically for obtaining subbottom penetration and reflections was constructed (Saucier 1970). Since that time significant advances in the operational design of acoustic profiling equipment have resulted in an array of systems which offer a useful and proven technique for a variety of geologic and engineering applications. Typical applications for which the CSRP method has been utilized include geological surveys, mineral exploration, foundation surveys for offshore structures, harbor development and maintenance, cable and pipeline route selection, and cultural resources surveys. Probably the greatest impetus for the continued development of the CSRP technique has been the offshore exploration for oil and gas resources. Equipment developed for deep subsurface penetration, i.e., 20,000 ft, is generally not



suitable for engineering applications in shallow-water nearshore and inland environments. However, spin-off technology from the development of the larger, more powerful systems has aided immeasurably in the design of small, low-powered, high-resolution CSRPs systems. These smaller systems are much more suited for applications in shallow water environments.

8. Side-scanning sonar is an adaptation of very high frequency vertical echo-sounding devices to provide an underwater side-looking capability. The side-scanning sonar technique is presently being applied to many types of underwater projects. The best known of these applications include bottom sediment mapping, geological mapping, archaeological surveys, navigation surveys, and pipeline surveys. The bathymetric profiling systems, more often called fathometers, offer a very important function of complementing the CSRPs and side-scanning sonar systems during the conduct of various types of acoustic profiling surveys. The major function of bathymetric systems is to acquire accurate water depth measurements. A secondary capability of bathymetric systems is their ability to provide a continuous profile of the bottom relief, often helpful in correlating bottom and subbottom data acquired with other types of acoustic profiling systems.

9. The prospective user of acoustic profiling equipment should understand the basic operational principles and design of the equipment to achieve optimum results during field applications and subsequent data analysis. Generally, all acoustic profiling systems are characterized by a sound source and a receiver or detecting device which are towed through the water by a survey boat. The source generates acoustic pulses, or pressure waves, at selectable intervals and durations. Most sources produce pulses in the 20- to 7000-Hz frequency range. The detecting component receives subsequent reflections from the bottom or the subbottom (Figure 1A). The returning or reflected acoustic energy is converted to usable electrical signals and is processed through system components and displayed on a paper record. These records show travel times between the transmitted pulse and the detected reflections (Figure 1B). The result is a continuous profile of the water bottom or



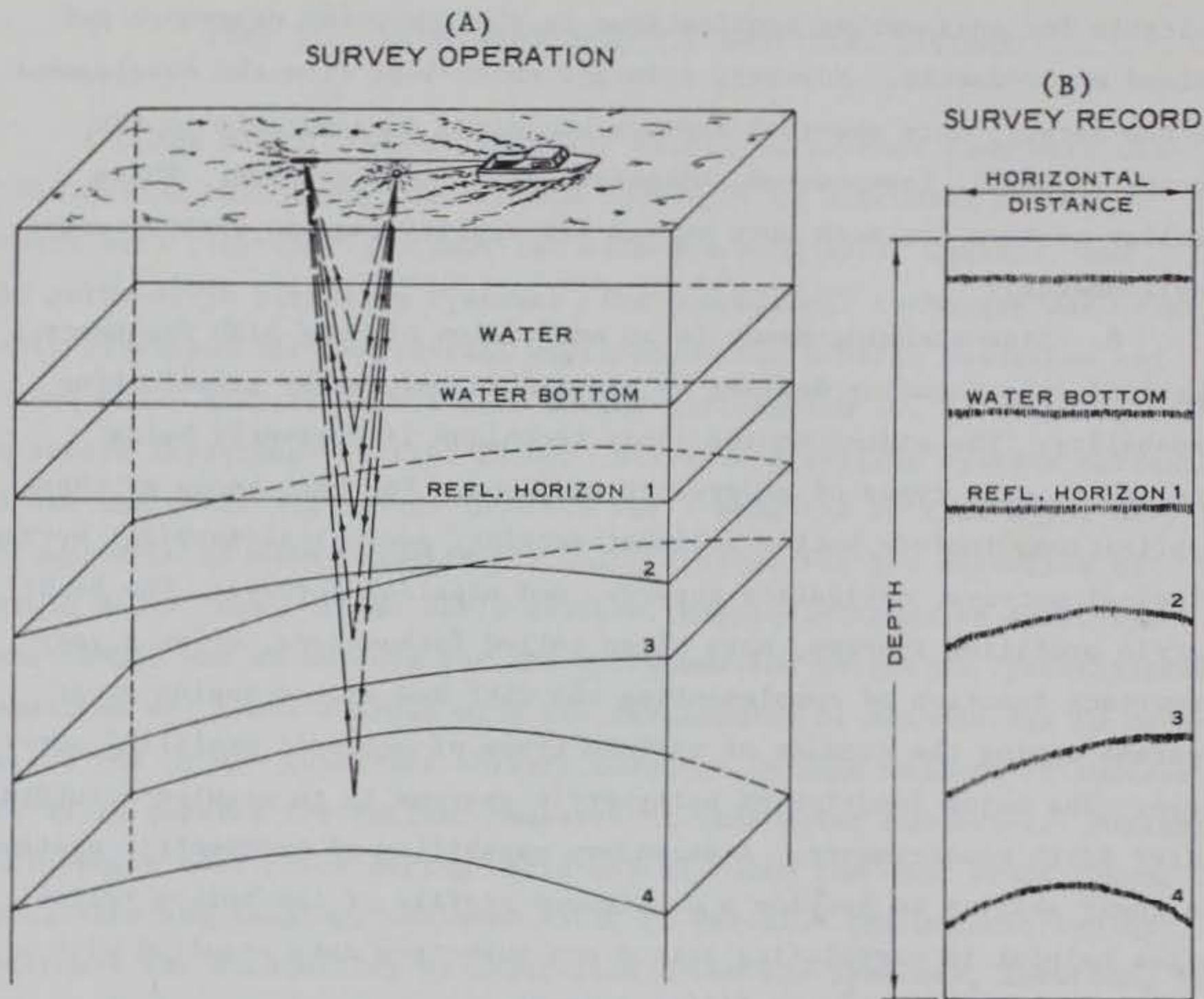

Figure 1. Basic operating principle of a continuous seismic reflection profiling system (from Saucier 1970)

subbottom along the axis of the survey line. The horizontal scale of the profile record is determined primarily by the speed of the survey boat and the paper advance rate of the recorder. The vertical scale of the profile record is usually controlled by the recorder sweep-rate. Travel time can be converted to depth if the velocity of the acoustic pulse through the media is known. Most system recorders are calibrated for travel times of 4800 fps, the velocity of sound in freshwater.

10. The basic principles of operation for side-scanning sonar systems is similar to that of CSRP systems except that much higher operating frequencies are used (i.e.,  $\geq 100$  kHz) and transmitted energy patterns are different. Side-scanning sonars transmit fan-shaped beams of acoustic energy to either side of a towfish containing two transducers--one



each on port and starboard sides (Figure 2A). The transmitted energy is highly directional. Horizontal and vertical main beamwidths are normally 1 to 1.5 deg and 20 to 35 deg, respectively. The transducers are offset from the horizontal at selectable angles so that the downward transmitted energy covers the bottom with two main lobes of energy at equal angles to the vertical on each side of the towfish (Figure 2B).

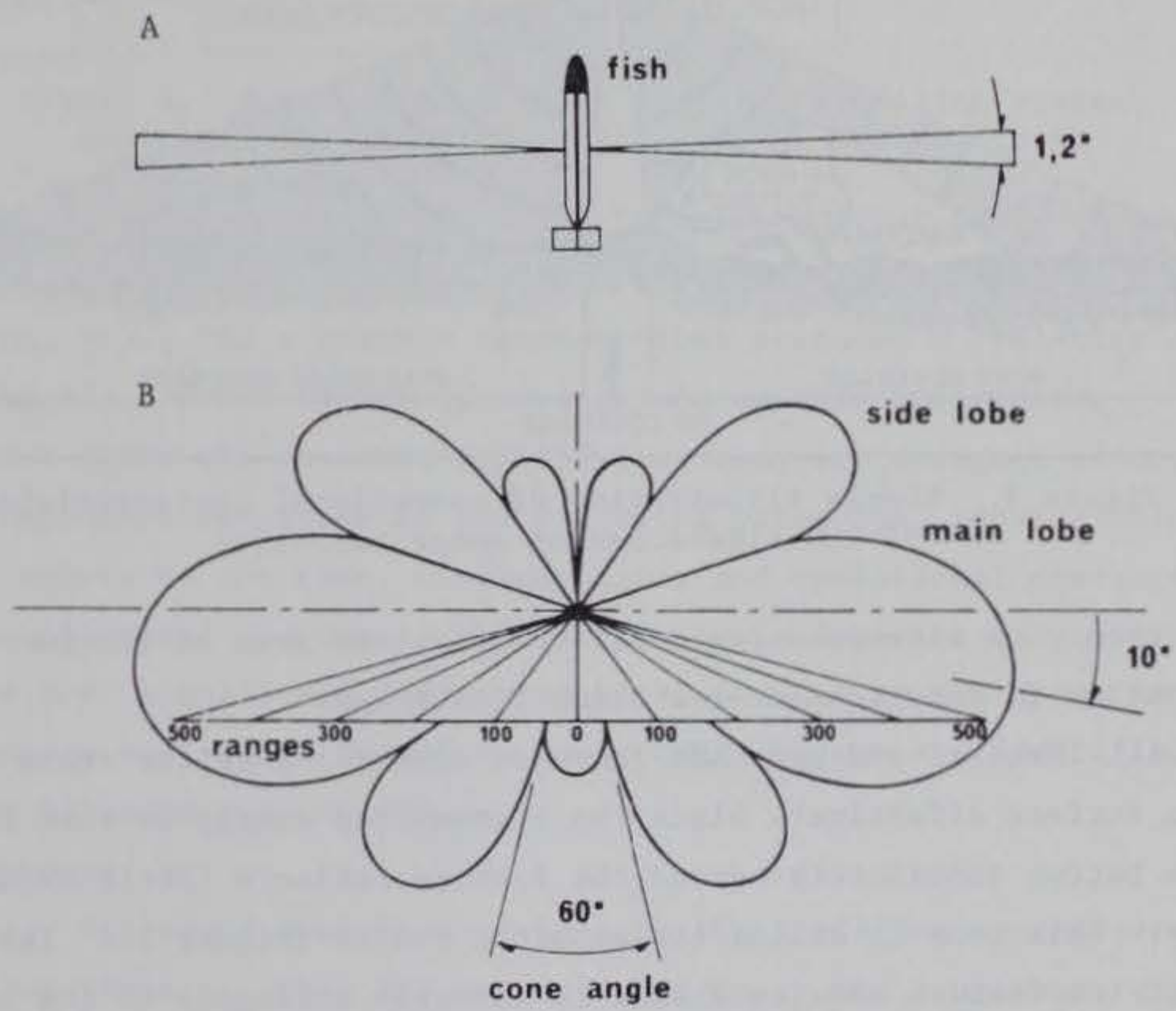

Figure 2. Transmitted acoustic energy beam pattern of a side-scanning sonar transducer array (Range units are horizontal ranges in feet. Horizontal view is A; vertical view is B. Courtesy of Environmental Equipment Division, EG&G International, Inc.)

As illustrated in Figure 2B, several smaller areas of transmitted energy make up the cumulative side-scanning sonar beam pattern. The "cone area" is a function of the height of the towfish above the water bottom (EG&G, Inc. no date). This area is roughly proportional to that area of the bottom directly below the towfish (Figure 3) where no energy strikes



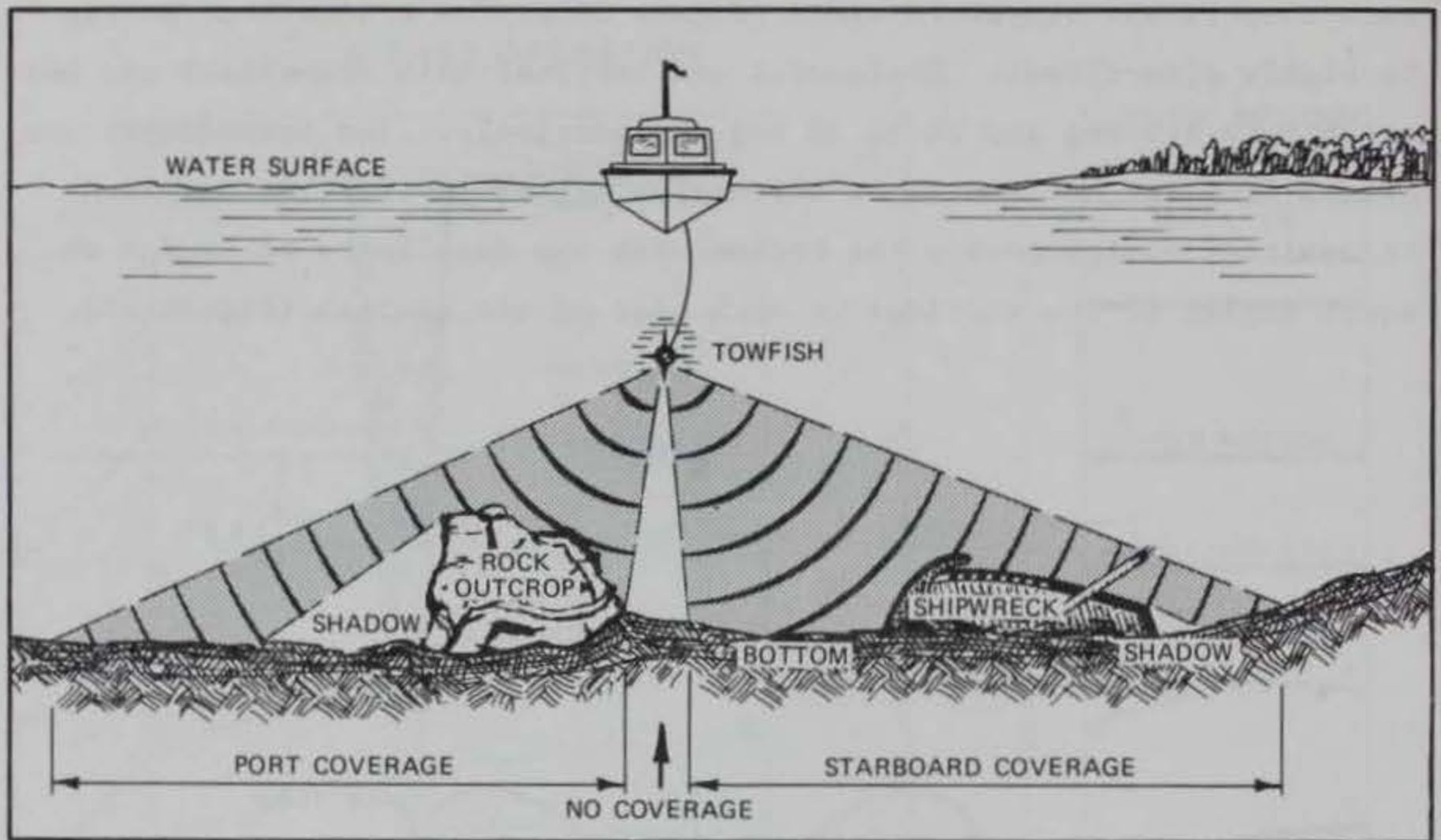

Figure 3. Simple illustration of operational characteristics of the side-scanning sonar technique

the bottom. On side-scanning sonar records, the area of the bottom below the towfish is represented by a blank linear gap.

11. Natural and man-made features exhibiting relief above the bottom surface effectively block the transmitted energy so that the area of the bottom immediately beyond the feature reflects little or no energy. This zone is called the acoustic shadow (Figure 3). The outline of the feature and its shadow is normally analogous to the configuration of the feature. Often, the acoustic shadow provides more significant clues to the target's identity than does the target itself.

#### Basic System Components

12. Figure 4 schematically illustrates the basic components and functions of most types of acoustic profiling systems. Each system requires: (a) a sound source (transducer) which generates an energy pulse of fixed or varying frequency levels; (b) a detector (hydrophone) that receives that portion of the acoustic energy reflected from the



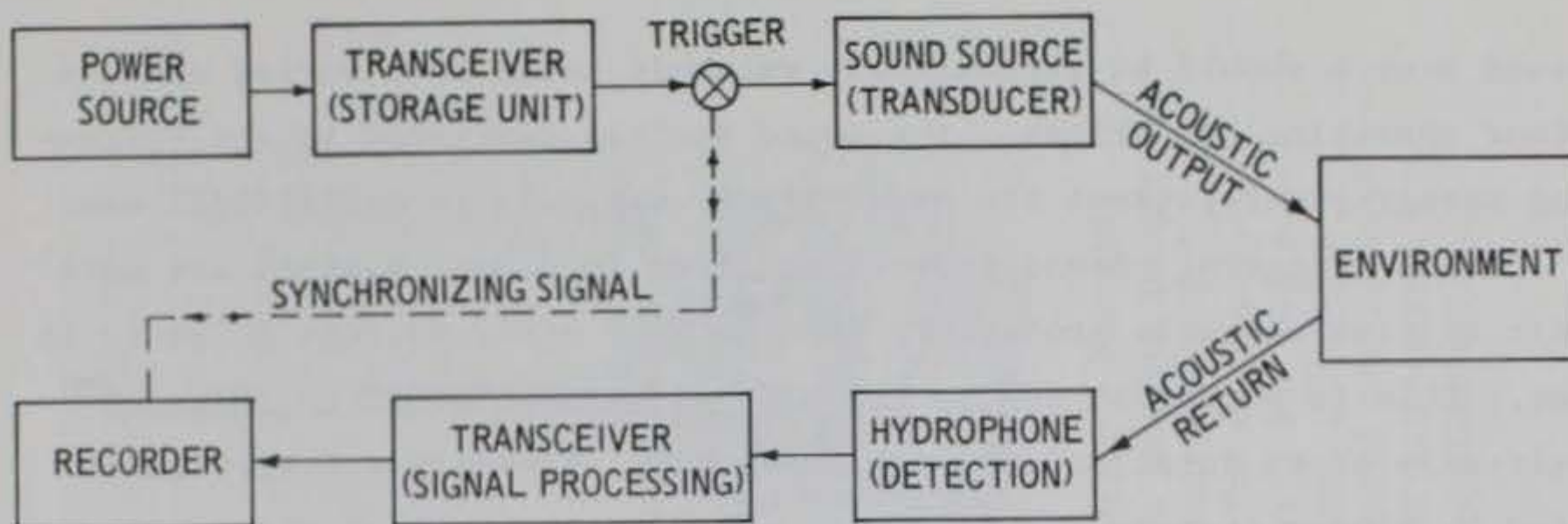

Figure 4. Basic components of acoustic profiling systems and their individual functions (after Saucier 1970)

bottom or subbottom reflectors; (c) a transceiver that performs several important system functions, including filtering, amplification, frequency selection, etc.; (d) a graphic recorder that produces a real-time display; and (e) a power source (generator) to operate the system.

13. While all acoustic profiling systems are designed around the basic components described in the preceding paragraph, considerable flexibility exists in the type, configuration, and operational characteristics of individual components that collectively comprise a system. Probably the most significant difference between major system types is the sound source employed. Therefore, most CSRPs are identified by the type of sound source used.

#### Sound sources

14. All sound sources used in acoustic profiling systems are similar in one respect: they are all designed to create a pressure waveform in the water. Each sound source represents a discrete range of operating frequencies and different operational capabilities. In order to meet most of the requirements necessary for practical application to project objectives sound sources should exhibit the following characteristics: (a) the transmitted waveform should be of sufficient strength to travel through the medium through which it is transmitted or reflected; (b) the transmitted pulse should be of short (i.e., 0.2 milliseconds or less) duration; (c) the repetition rate of the transmitted pulse (pulse rate) should be at least 1 pulse per second (pps) or greater; (d) the beamwidth of the emitted energy should be as narrow as possible; and (e) the



sound source should be mechanically reliable under both varied and constant operating conditions. The sound sources described in the following paragraphs represent the basic types currently in operational use.

15. Pingers. Sound sources utilized in pinger systems are more akin to true acoustic projectors than are the other sources commonly in use. This is primarily due to the high intensity "ping" or pulse of extremely short duration and high pulse rate characteristically generated by pinger transducers. Little or no displacement of water is involved to create a waveform such as occurs with the electromechanical sources used in other types of profilers. Most pinger, side-scanning sonar, and bathymetric profiling systems use the piezoelectric transducer as a sound source. These transducers operate both as a source and as the hydrophone receiver. Piezoelectric transducers consist of an array of crystals immersed in oil in a cylindrical, or linear-shaped housing. Electrical agitation of the crystals produce the acoustic energy either at a fixed-frequency or variable-frequency range. Pinger systems presently in operational use operate primarily in the 1- to 16-kHz frequency range. Pingers normally generate the highest frequencies and produce records of the highest resolution. However, because of their high frequency characteristics, pingers are generally unable to achieve the depth of penetration of the subsurface obtainable with other lower frequency sources. Transducers used in pinger systems may be mounted singularly or in multitransducer arrays. Two pinger systems designed for "over-the-side" towing are shown in Figure 5. A side-scanning sonar transducer vehicle (towfish) is illustrated in Figure 6.

16. Boomers. Boomer profilers operate with a unique electro-mechanical-type source. The source assembly consists of an electrical coil which is magnetically coupled to a metal plate (Figure 7). Electrical energy is discharged at various levels into the coil. This results in a strong, rapid outward force on the plate. A rubber diaphragm forces the plate back against the coil after each outward movement of the plate. The plate motion in the water generates clean, short duration pressure pulses covering a wide frequency spectrum, i.e., 400 Hz to 14 kHz or more. A complete boomer transducer vehicle is shown in Figure 8.



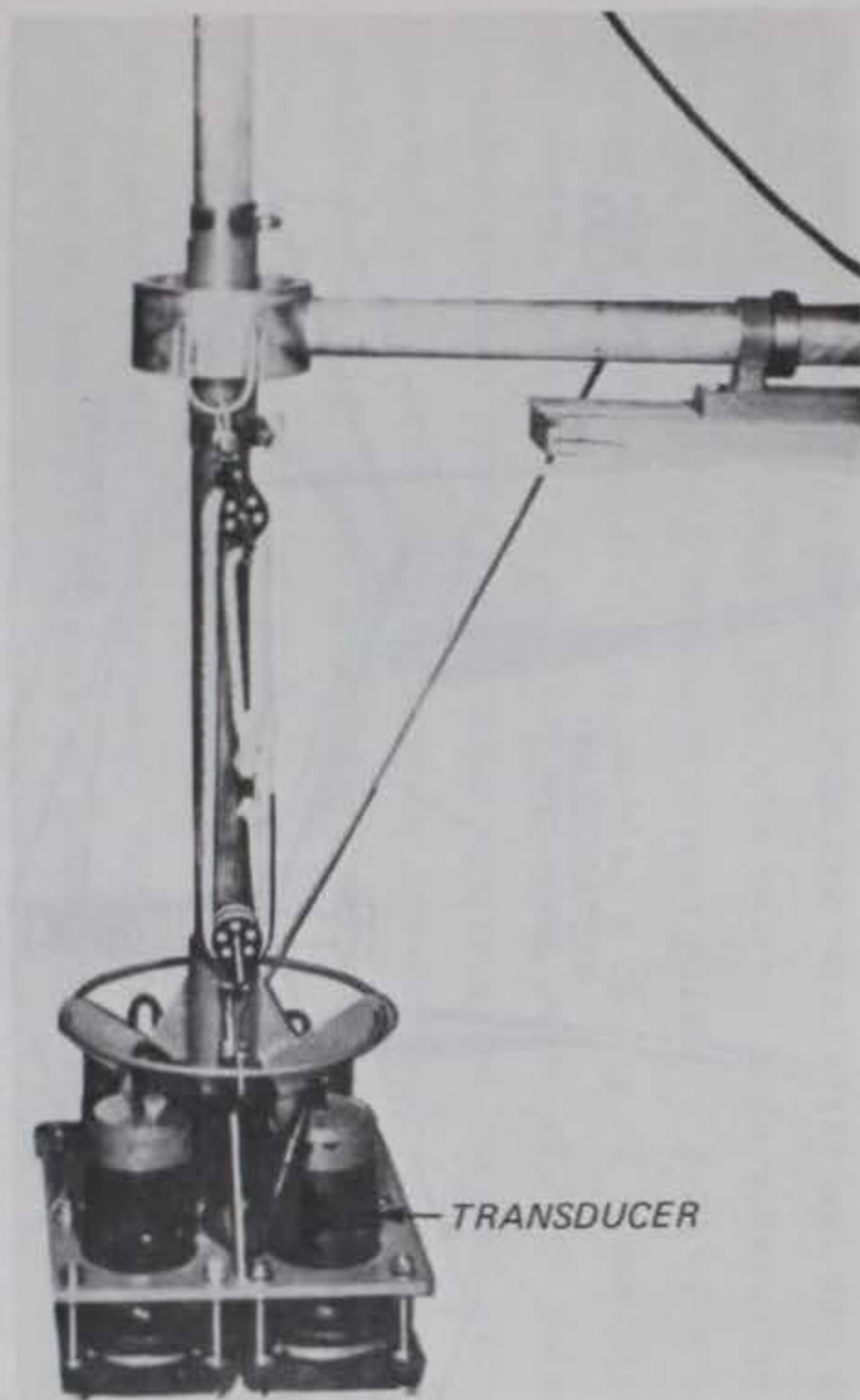

a. Ocean Research Equipment, Inc.  
Model 1032 pinger transducer array  
(courtesy ORE, Inc.)



b. The Raytheon RTT-1000A-1 Portable Survey System, a small, compact pinger system designed for "over-the-side" towing configuration (The system operates at either 3.5 or 7 kHz for sub-bottom profiling. A small, 200-kHz transducer may be attached for acquisition of high resolution bathymetry. Courtesy of Raytheon Company.)

Figure 5. Two pinger systems



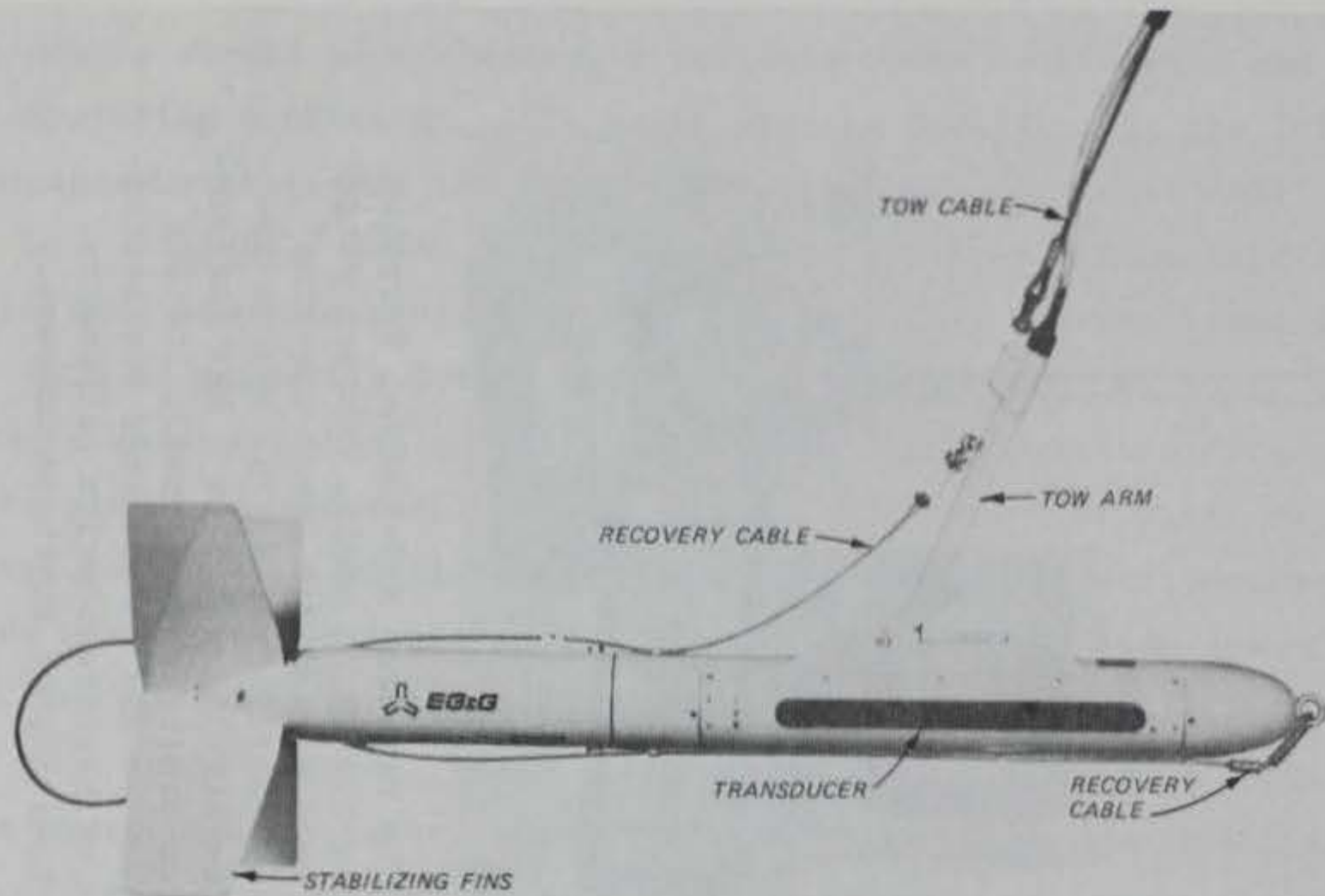

Figure 6. Towed transducer vehicle (towfish) for EG&G International, Inc. Mark 1B Side-Scanning Sonar System (courtesy of Environmental Equipment Division, EG&G International, Inc.)

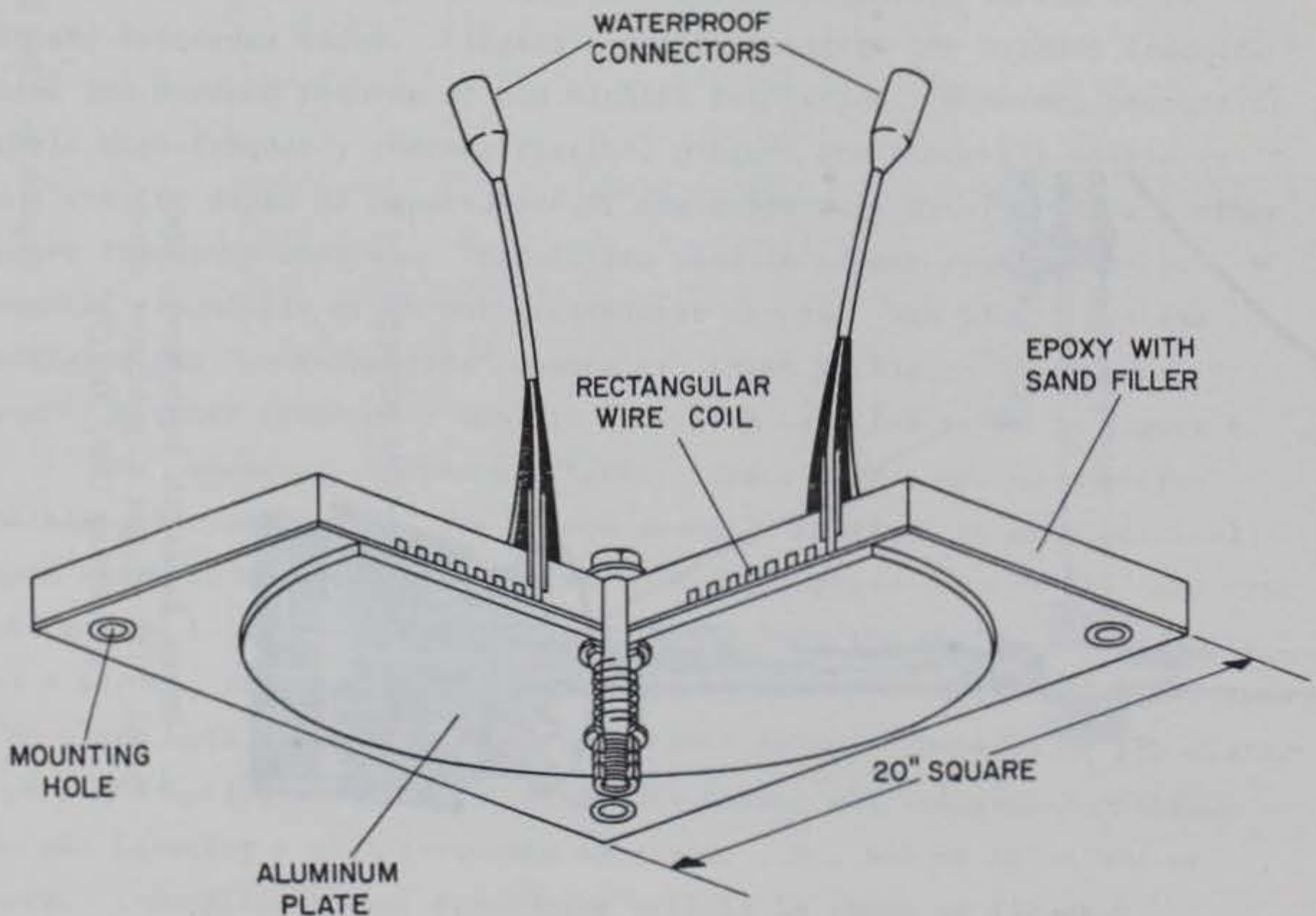

Figure 7. EG&G, Inc. Standard Boomer sound source (courtesy of EG&G International, Inc., Environmental Equipment Division)



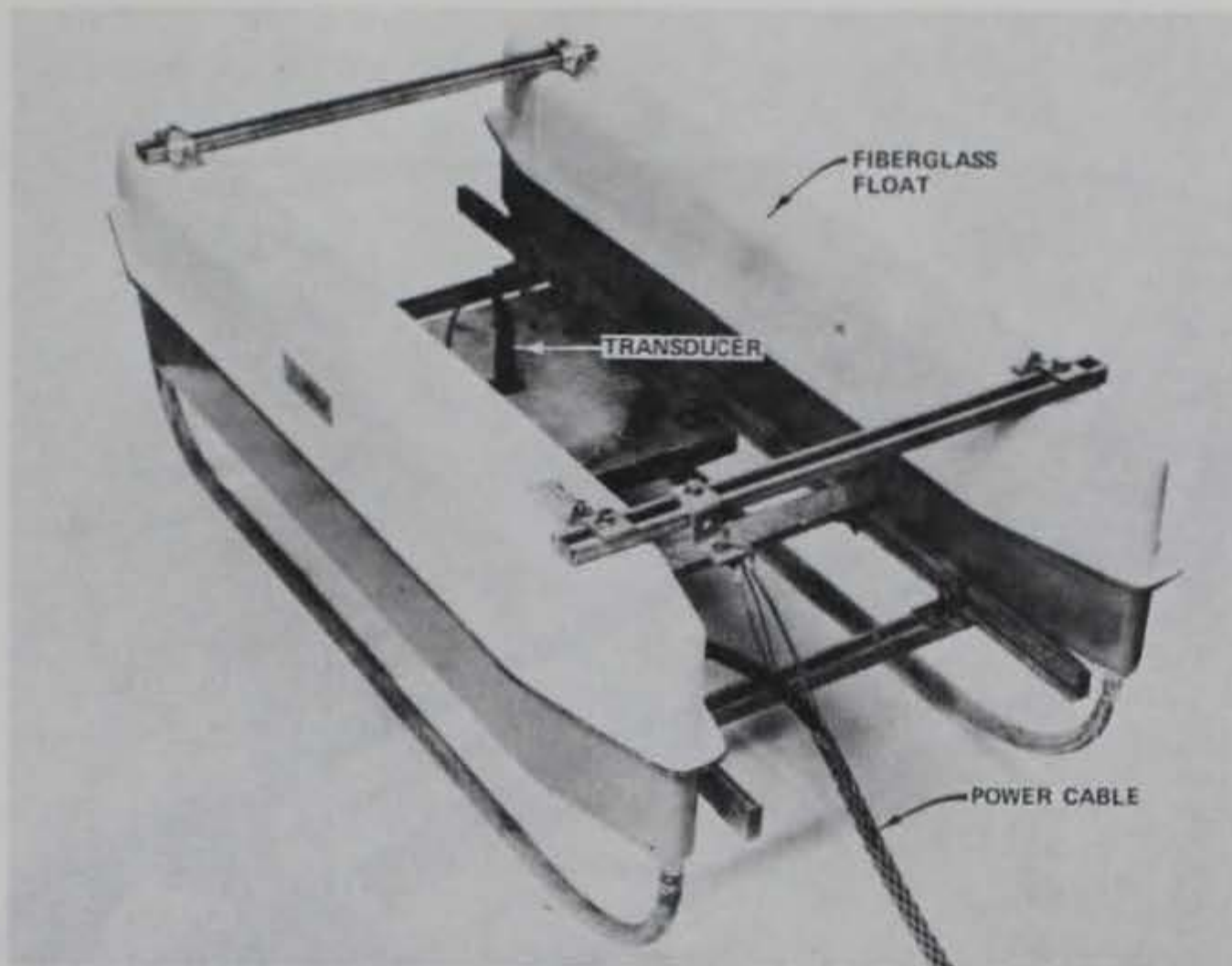

Figure 8. Model 230 Uniboom towed transducer vehicle manufactured by EG&G International, Inc. (courtesy of Environmental Equipment Division, EG&G International, Inc.)

17. Sparkers. The sparker source consists of an electrode, or an array of electrodes, mounted on a towing frame or streamer (Figure 9). The acoustic pulse is derived from the source through the discharge of electrical energy directly into the water. This underwater spark creates an explosively formed pressure pulse in form of a bubble at the tip of the electrode(s). The bubble, a cavity of steam plus ionized gas, or plasma, generates a positive acoustic pulse of high intensity. Most sparker sources produce frequency ranges of 40 to 1000 Hz. Because sparkers characteristically produce low-frequency energy of long pulse duration and high power levels they are capable of deep rates of penetration, i.e., 10,000 ft or more.

18. Air guns. Pneumatic sources, popularly referred to as air guns, generate very low frequency waveforms in the water as a result of the sudden, explosive release of compressed air. Similar to the spark-generated pulse, a bubble is formed by the release of air, producing the pulse. The useful frequency range obtainable with air gun sources is



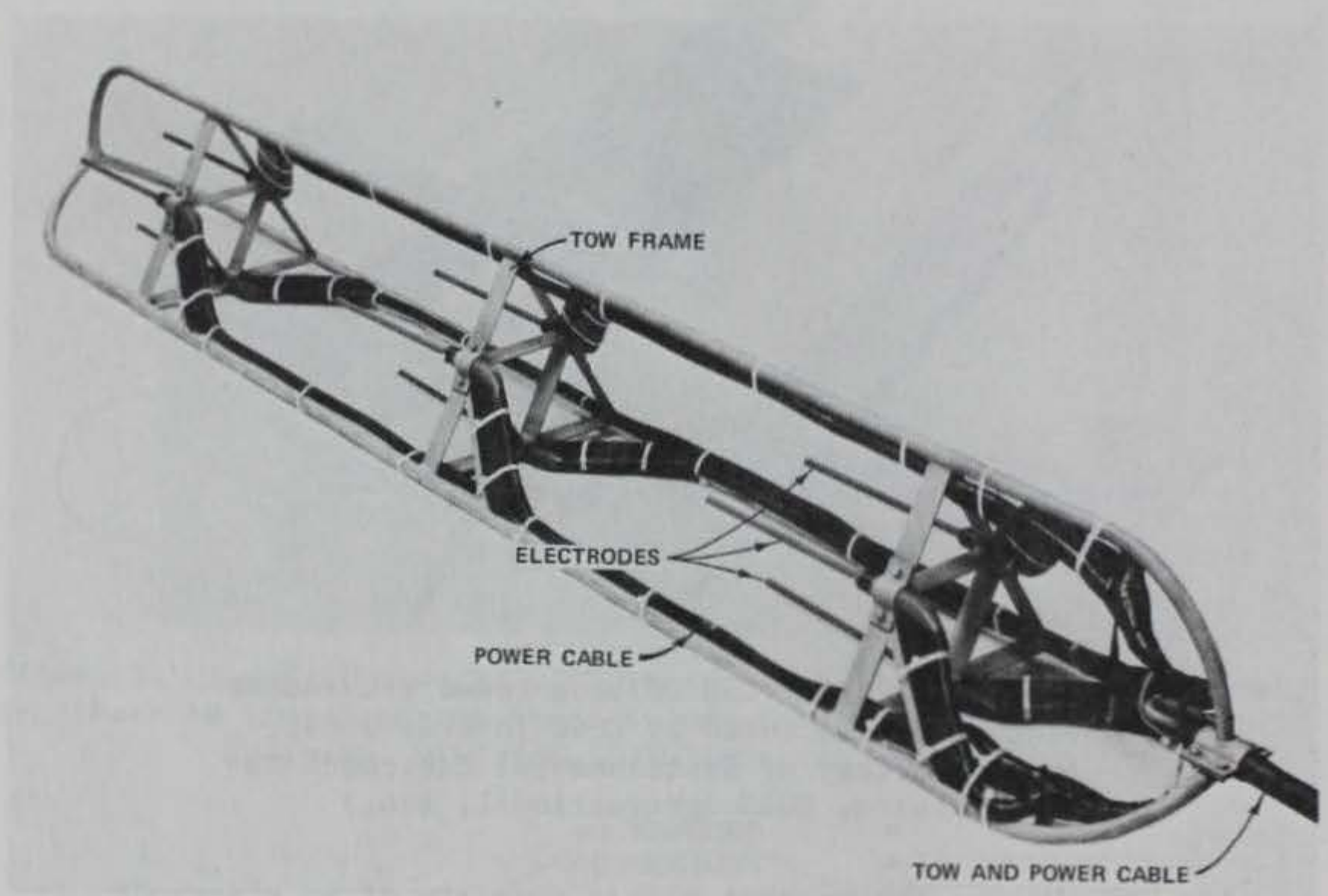

Figure 9. Nine-electrode sparker array vehicle manufactured by EG&G International, Inc. (courtesy of Environmental Equipment Division, EG&G International, Inc.)

about 5 to 120 Hz, depending on the volume of air release, depth of the towed gun, air pressure level, etc. Penetration of the subbottom in excess of 10,000 ft has been achieved with air guns. An air gun source is shown in Figure 10.

19. Thermodynamic sources. A number of these sources, called "gas guns" within the geophysical community, have been developed to study deep geological structures. (Penetration of 20,000 ft has been reported.) Gas guns produce an underwater bubble pulse through the release of energy created by the ignition of explosive gas mixtures (normally propane and oxygen). Energy released by the gun is



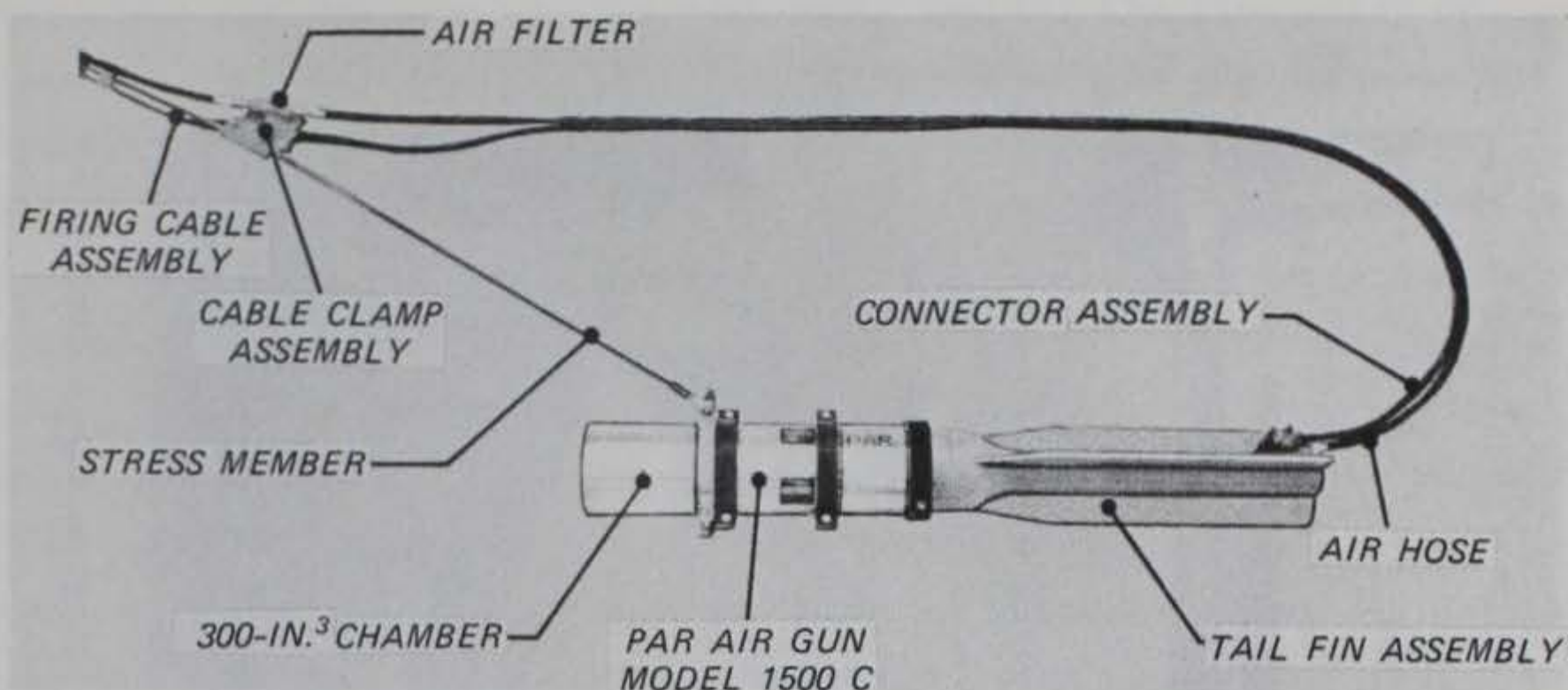

Figure 10. Model A-2300 towing assembly for PAR Air Gun (courtesy of Bolt Associates Inc.)

characterized by low frequencies, normally less than 100 Hz. Figure 11 shows a thermodynamic source which utilizes multiple miniexplosions to generate a broadband, directional pulse in the water.

20. In summary, sound sources may be placed into two specific categories: (a) the piezoelectric transducer which may be used as both a source and receiver, and (b) the electromechanical sources which utilize separate source and receiving elements. Each of these source types have their particular advantages (and disadvantages), depending upon the application for which they might be employed. The profiling systems which use the piezoelectric transducer as a source can transmit short acoustic pulses resulting in very high resolution and offer inherently narrower beamwidths which increase the efficiency of the system. Those systems using sources where the acoustic pulse is generated by an electrical or mechanical event in the water can emit energy of very low frequencies, which results in deeper penetration of the subsurface. However, the data resolution is generally less than that obtained with piezoelectric transducers.

#### Hydrophones

21. As briefly mentioned in the preceding paragraphs, two general types of hydrophone receiver configurations are used in acoustic profiling: (a) the fixed transducer-type where the transmitting and receiving





Figure 11. Thermodynamic source in a towing configuration utilizing multiple firing sleeves (courtesy of Odom Offshore Surveys, Inc.)



functions are performed by the same unit, and (b) the line-array or streamer hydrophone. The dual-function transducer is advantageous because it can be used within or in very close proximity to the survey vessel. This advantage results because the operating frequencies of the transducer are significantly higher than the frequencies contained in background and other noise sources. The line-array hydrophone, used as a separate receiving component with boomer, sparker, air gun, and gas gun sources, must be towed at various distances from the survey vessel and the source. This type of hydrophone is normally constructed of flexible plastic tubing of various diameters (usually 3/4 to 2-1/2 in.), and can range in length from several feet to several thousand feet. The tubing is filled with electrically conductive fluid and is neutrally buoyant. The tube may contain a single detecting element or a series of elements (Figure 12). The detectors are piezoelectric transducers which are extremely pressure sensitive. These elements differ from geophones in that they detect pressure rather than motion. The detectors are connected and a single channel carries the generated electrical pulses to the recording components. The line-array hydrophone normally includes a preamplifier to boost the detected signal strength level.

#### Transceivers

22. The transceiver performs a number of essential system functions. The transceiver may be configured as a separate component of the system, or its major components may be contained within other system components such as the graphic recorder. Transceivers are probably more commonly associated with side-scanning sonar, pinger, and bathymetric systems. The principal functions of the transceiver include filtering, amplifying, power output control, and frequency control.

#### Recorders

23. The principal function of the graphic recorder is to provide onsite, real-time records of the acoustic profile data. The recorder also performs other key functions, such as triggering of energy and sound sources at various rates; control of printing scales and speeds; and signal strength (gain) of the printed record. Graphic recorders available at the present time are designed so that they may be interfaced



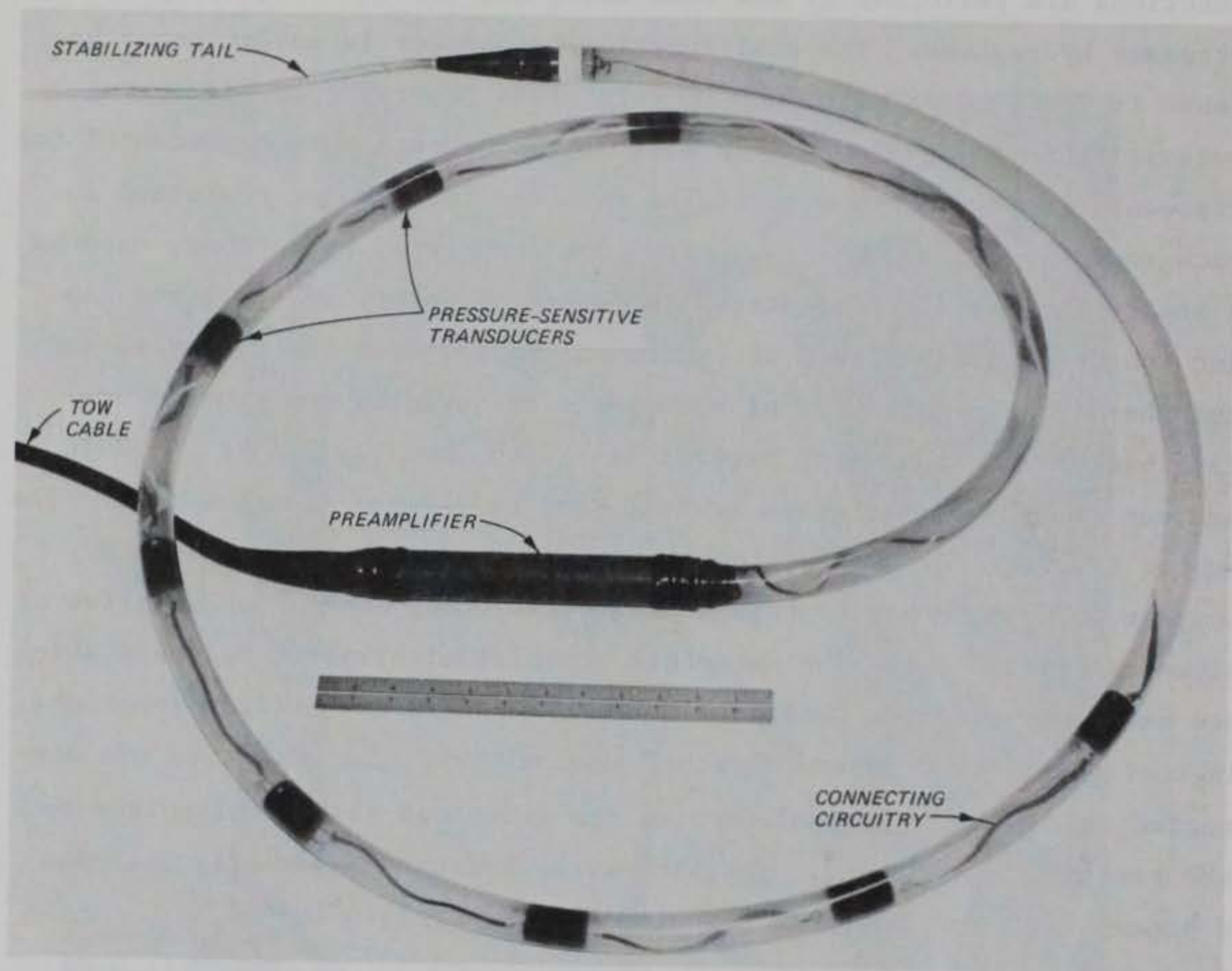

Figure 12. Model 265 hydrophone, an 8-element array manufactured by EG&G International, Inc. (courtesy of Environmental Equipment Division, EG&G International, Inc.)

readily with most acoustic profiling sources. Probably the most noticeable difference between the various recorders available today is the type of paper used. Some recorders utilize a "wet" recording paper that is electrochemically treated to provide high conductivity (Figure 13). The recorder "writes" by passing an electrical impulse from a negative component to a positive one. Ferrous ions are deposited on the paper in shades of intensity that depend on the intensity of the reflected energy. Other graphic recorders use dry recording paper. The record is printed by means of an electrical signal on a moving electrode that burns off a thin layer of the recording paper to expose a black underlying layer. A commonly used recorder utilizing dry recording paper is shown in Figure 14.



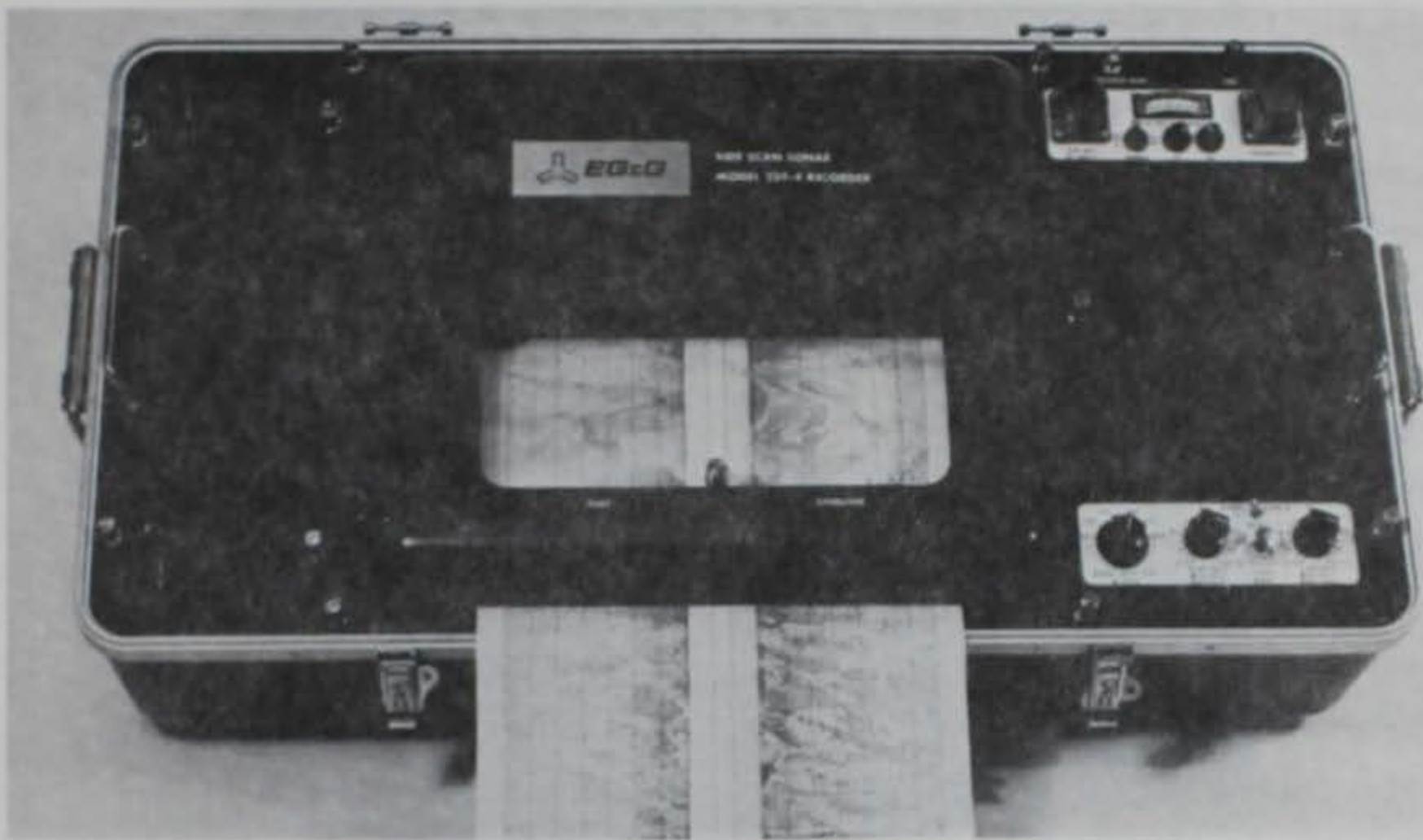

Figure 13. "Wet-paper" type recorder used with Model Mark 1B Side-Scanning Sonar System (courtesy of Environmental Equipment Division, EG&G International, Inc.)

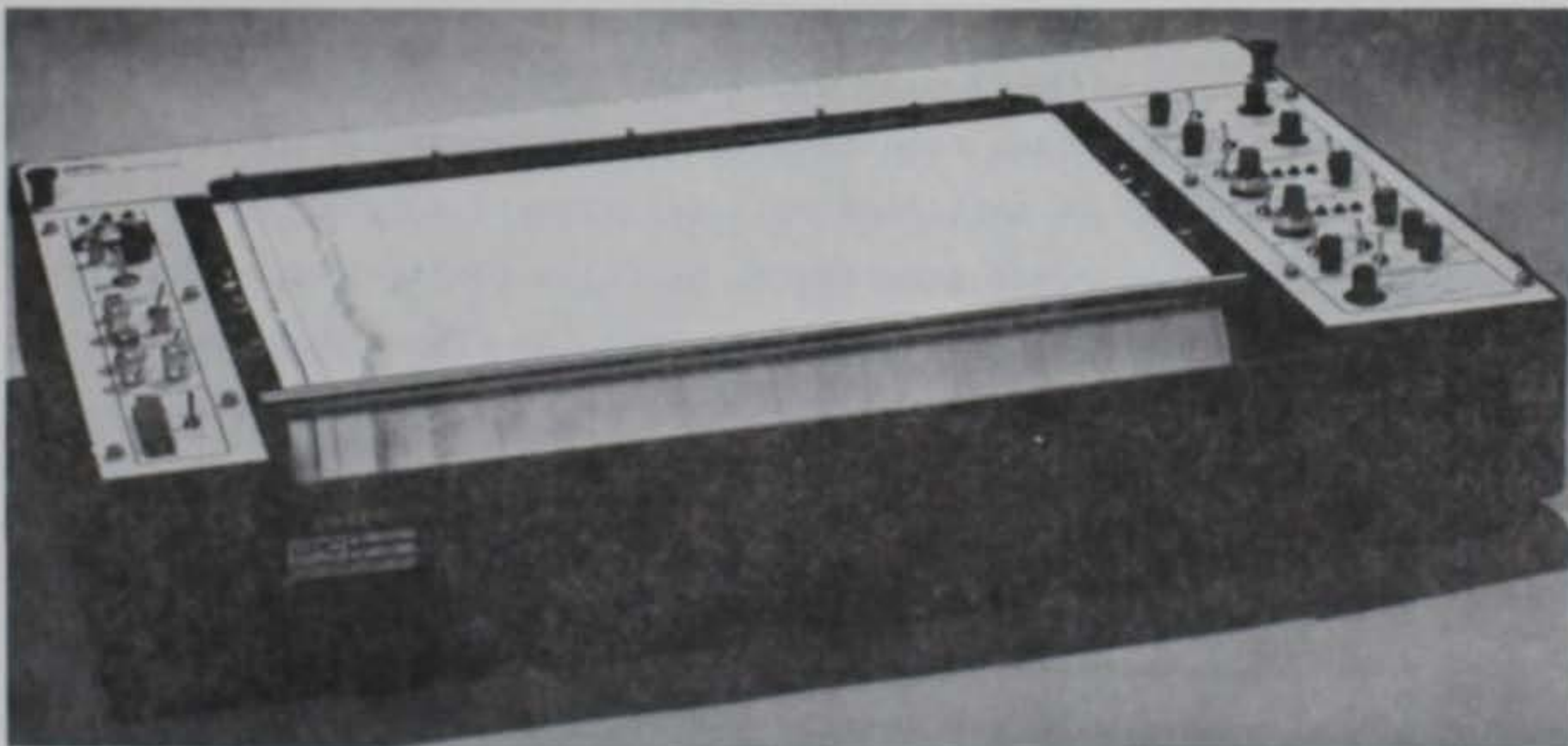

Figure 14. Model 3200 dual-channel graphic recorder manufactured by EPC Labs, Inc. (This recorder uses a 19-in.-wide dry-type paper.)



## Energy storage and power supply components

24. Energy storage components, i.e., capacitors, and power supply components are key parts of all acoustic profiling systems. Capacitors store energy at various levels (depending on the power output capacity of the source) and power supply components generally contain circuitry for the charging of the capacitors. Power supply units also contain triggering circuits which are activated by signals from the recorder, resulting in the discharge of the stored energy into the sound source. Discharge-type sources, i.e., sparkers and boomers, utilize separate capacitor and power supply components because of the large amounts of power required by the source. Pinger, side-scanning sonar, and bathymetric profiling systems normally incorporate capacitor, power supply, and triggering components within the recorder or the transceiver. Figure 15 shows a compact component which combines the capacitor and power supply functions into a single unit. Units of this type are extremely versatile and can be utilized for several discharge-type sound sources.

## Power sources

25. Electrical power requirements for the operation of acoustic profiling systems can be satisfied by: (a) onboard survey vessel power systems, (b) portable power generators, or (c) a combination of both. Power requirements are largely dependent upon the type and number of profiling systems employed during a survey. Survey vessels designed specifically for seismic or hydrographic surveying normally have adequate onboard power systems that will supply the requirements of a wide range of acoustic profiling systems. Portable generators in the 2- to 6.5-kw range will normally provide ample power output levels to operate most small to medium size acoustic survey systems. The majority of these systems generally require only 110- to 220-vAC power input, although some will operate from 12- to 24-vDC power supplies. When multiple acoustic profiling systems and related ancillary support equipment





Figure 15. Energy source component that combines power supply, trigger circuitry, and capacitors in a compact package (courtesy of EG&G International, Inc.)

are operated simultaneously, the power demand will consequently be greater. System operational efficiency and performance is normally higher if sound source and recording components are supplied by separate power sources, primarily because of the possibility that power surges will occur during the charging and discharging of capacitor banks. Since power requirements are a critical part of any acoustic profiling program, it is extremely important that adequate power supply sources are utilized. Having more power than required by the system(s) is much better than not having enough power.

#### Ancillary system components

26. A number of components of various types and functions, while not always integral parts of basic off-the-shelf acoustic profiling systems, are useful and often necessary for optimum profiling results. A few of the most useful ancillary components are discussed below.

27. Filters. Some acoustic profiling systems, particularly



those utilizing separate source and receiver components, require a signal processing filter. This filter is characteristically a variable bandpass filter similar to the one shown in Figure 16. Bandpass filters are frequency-discriminating instruments whose signal transmission characteristics are functions of frequency. Their basic purpose is to pass wanted signals and to suppress undesirable signals.

28. Amplifiers. Although most profiling systems incorporate required signal amplification components within the system, it is often desirable to utilize an external amplifier for more flexibility in boosting returning signal strength. After a reflected signal has been



Figure 16. Signal processing components commonly utilized with small acoustic profiling systems



detected by the hydrophone, it must be amplified and filtered before it can be recorded. This is usually accomplished by preamplifiers and amplifiers located in various system components such as the hydrophone, transceiver, and recorder. However, under certain operating or environmental conditions, further amplification is frequently required. For this reason, small external amplifiers are sometimes used to boost the signal strength to a more useful level than the basic system components are able to achieve. An external amplifier of the type commonly used as an ancillary component to acoustic profiling systems is shown in Figure 16.

29. Tape recorders. Probably the most useful piece of ancillary acoustic survey system components is a magnetic tape recorder. While the graphic recorder displays bottom and subbottom survey data in real-time as the survey progresses, it has no provision for storing raw data for subsequent processing. The real value of the tape recorder lies in its ability to record the raw returning acoustic reflections over the reflected signal frequency spectrum. Placing the returning raw data on tape permits the replaying of the data using a variety of processing techniques which, when coupled to recorders and data processing equipment, may result in a new record of a quality exceeding that of the real-time display record. The most widely used recorders are the multichannel, reel-to-reel instrumentation recorders available in numerous configurations and price ranges. The tape recorder shown in Figure 16 is a "home stereo" recorder that provides satisfactory results for acoustic profiling surveys of limited scope.

### System Limitations

#### Frequency and resolution

30. In CSRP, the capability of the system to resolve the smallest object, or the thinnest sediment layer, is primarily dependent upon the frequency characteristics of the waveform emitted by the source. Generally, CSRP systems cannot resolve a sediment layer whose thickness is less than one-half the wavelength of the acoustic pulse. For example,



at a frequency of 1 kHz, the wavelength of the pulse in sediment is approximately 6 ft. Therefore, a sediment layer of less than 3 ft (one-half the wavelength) probably could not be detected by the system. Since resolution capability of acoustic profiling systems increases in direct proportion to an increase in frequency, the high frequency CSRP systems--e.g., those that produce sound in the 3- to 14-kHz frequency range--normally produce records of the highest resolution. However, these systems are limited in their capability to penetrate as deeply into the subbottom as the low-frequency CSRP systems. This conflict between resolution and penetration is fundamental and must be considered in any application of CSRP systems.

31. Since side-scanning sonar systems are not designed for penetration of sediments, the frequency-penetration-resolution problem is not of concern in side-scanning applications. However, the high frequency characteristics of side-scanning sonar can present problems in some water bodies characterized by extremely high suspended sediment loads. The sediment particles block effective transmission of acoustic pulses so that meaningful reflections from the bottom are not received.

#### Source directivity

32. A source's directivity of emitted energy normally depends on the ratio of the emitting surface to the emitted wavelength. High-frequency sources are generally characterized by narrower zones of transmitted energy, while the low-frequency sources tend to emit energy in omnidirectional patterns. Omnidirectional sources do not pose any particular problem until the source is employed in restrictive water bodies, i.e., rivers, canals, etc. Emission of acoustic energy in a narrow channel may be reflected not only from the channel bottom, but also from the banks of the channel or structures located within the confines of the channel. Reflected signals of this nature, generally referred to as "side echoes," arrive at the system recorder with reflected bottom or subbottom signals and often confuse or override valid data.



## Environmental Limitations

33. Various environmental conditions may have significant influence upon the conduct of acoustic profiling surveys and the quality of data acquired during these surveys. The best designed system capability may be compromised if the interactions of environmental processes that directly or indirectly affect the performance of profiling systems are not recognized. To meet the objectives of an acoustic profiling survey, the array of equipment, operational procedures, and personnel should be geared to the environmental and physical parameters that may be encountered within the survey area. Because the study reported herein concerns operations within fluvial environments, the following discussion of several important environmental parameters is generally restricted to parameters commonly encountered in fluvial environments. Many of these parameters, however, are also common in other water bodies and would have to be considered prior to acoustic profiling operations.

### Hydrologic parameters

34. Water depth. The depth of water can affect an acoustic profiling survey in several ways. First, water depth may determine the type of survey boat and source/receiver towing configuration that can be used during the survey. Shallow-water profiling often means working in water depths of less than 10 ft. (Surveys in water depths as shallow as 4 ft have been reported.) "Over-the-side" source arrays may be more advantageous compared to moderately or deeply towed arrays because of greater control over source depth and consequently less danger of striking bottom or submerged structures. Second, shallow water depths often generate closely spaced, rather intense multiple reflections of the water bottom. Although multiple reflections can and do occur in deeper water environments, they will be spaced correspondingly farther apart on the record and present less of a problem in data interpretation. Third, at deeper water depths, the area of the receiving emitted source energy increases. For this reason, CSRP data in deep water will tend to show average conditions over a wider area rather than a specific profile directly below the survey line. Fourth, water depth may govern the



amount of transmitted power output, and thus the types of sources that are used. Excessive levels of power output in shallow water may result in the deterioration of the record data by increasing noise levels or the intensity of multiple reflections. Too little power output capability, on the other hand, in deep water environments may result in limited bottom penetration.

35. Channel configuration. The geometry of river channels can also affect the manner in which an acoustic profiling operation is conducted, the type of systems used, and the quality of the data required. The sinuosity, width, and variations in the depth of the channel are channel parameters that can have significant impact on the operational performance of acoustic profiling systems and the conduct of the survey. Layout of profiling lines must be accomplished in a fashion designed to satisfy both the data requirements and the operational envelope of the survey equipment. For example, some considerations should be given to the size and maneuverability of the survey boat, the simplicity of navigation, and the volume of private and commercial boat traffic within the proposed survey area. The problem of side echoes, reflected from nearby banks of a narrow channel, could influence the selection of CSRPs sources since some omnidirectional sources are susceptible to problems of this type. The horizontal scale of the profile record must also be considered since the brevity of a cross-channel section profile line might impose serious interpretive difficulties.

36. Channel obstructions. Nearly all fluvial environments, particularly those utilized for navigation, have associated man-made structures and natural obstructions located randomly along the length of the waterway. Structures such as bridges, dock facilities, locks and dams, training dikes, buoys, etc. are commonly encountered during profiling operations in river channels. If care is exercised, these structures do not normally pose any serious danger to equipment in the water. However, they may restrict the orderly arrangement of survey lines and the areas that can be profiled. Natural obstructions that normally occur within fluvial channels include sand bars, debris of various kinds, trees, and rock outcrops. Natural obstructions such as sand bars and debris may



represent more problems than most obstacles due primarily to their unpredictable locations and transient nature.

37. Variation in salinity levels. Although variation in salinity level is normally encountered only in estuarine environments, nevertheless it poses a problem over a significant area of the United States and warrants mentioning. Most acoustic profiling systems will operate equally well in either freshwater or saltwater. The major exception is a sparker system. The sparker source must be operated in water having a minimum salt concentration of about 15,000 ppm in order to generate the required spark between the electrodes. In water where the saline content is low, or in inland freshwater where saline content is nil, modifications can be made by enclosing the entire sparker source in a brine-filled, sealed polyethylene bag or hose. While the modified array may prove hydrodynamically more cumbersome than the conventional towing configuration, it does provide a means by which sparker sources can be utilized in freshwater riverine environments.

38. Discontinuities in the water column. Discontinuities in the water column include (a) air bubbles, (b) suspended materials, and (c) temperature variations. These discontinuities are discussed below:

- a. Air bubbles. Normally, bubbles represent little or no problem to the proper functioning of CSRP and side-scanning sonar systems when they occur singularly, but can be important when they occur in large masses. Air bubble masses entrained in the water can scatter or attenuate transmitted acoustic energy, regardless of the intensity of the acoustic pulse. Large concentrations of air bubbles normally occur where turbulent water flow characteristically occurs in the wakes of boats, around the ends of structures such as dikes, bridge piers, piling, etc. Eddies, boils, and other forms of turbulence associated with streamflow produce significant amounts of bubbles that can result in less than desirable system performance in river channels. Streamflow turbulence is normally at highest levels during high water stages.
- b. Suspended materials. As previously mentioned, high concentrations of suspended sediment can result in above-bottom reflection or attenuation of acoustic energy. Other materials, e.g., vegetative matter, can also result in premature reflection of the transmitted energy. CSRP systems normally are not affected by suspended materials



within the water column because of the inherently lower frequencies used by these systems. Those systems, e.g., side-scanning sonar, bathymetric, and some CSRP systems, that characteristically produce high-frequency energy, i.e., normally above 100 kHz, often encounter problems where high concentrations of suspended materials occur. One of the most common suspended sediment conditions encountered in some riverine environments is a low density material (densities range from 1050 to 1150 g/l) popularly called "fluff." This type of low density material is invisible to low-frequency profilers, but can reflect high-frequency signals effectively, often resulting in an erroneous display of bottom relief and water depths.

- c. Temperature variations in the water column. Temperature inversions within the water column can sometimes result in the attenuation of high-frequency acoustic signals. Water temperature changes may also result in variations in the velocity of transmitted acoustic energy, resulting in variations of water and subbottom reflection depths displayed on the record. Temperature differentials of sufficient levels to interfere with transmitted acoustic energy usually occur only in extremely deep water bodies, i.e., offshore marine environments and deep lakes.

39. Water surface conditions. Water surface conditions include (a) roughness, (b) ice, (c) turbulence, and (d) debris. These conditions are discussed as follows:

- a. Roughness. Degree of water surface roughness may affect the quality of acoustic reflection data and the time required to conduct an acoustic profiling survey. Normally, surface water roughness, i.e., wave action, is not as serious a factor in riverine environments as compared to marine environments. However, on large river systems where reaches of considerable length are common, significant wave heights can be generated by moderate winds of sustained duration, particularly if the prevailing winds are against the direction of flow. Towed transducer arrays that are operated at several feet or more below the water surface are less affected by surface water roughness than surface units. Generally, those systems that utilize a separate hydrophone array at or near the surface are most susceptible to a deterioration of data quality from wave action. The deterioration of data is normally due to the increase in noise levels and loss of signal when the hydrophone is pushed out of the water by wave action. On large river systems where commercial barge and towboat traffic is heavy, significant wave action and turbulence can be generated by passing traffic.



- b. Ice. Normally, acoustic profiling operations are conducted in those months of the year, i.e., April to November, when meteorological conditions are usually more suitable. Ice, although not common in most marine environments, can be a problem for operations on inland waters. Streams located in regions where harsh and sustained winters are common may ice-up for long periods of time, or experience frequent freezes. Even random ice floes within the channel make conducting surveys safely virtually impossible. Consequently, surveys should be planned for ice-free months of the year when possible in those regions where ice conditions are common during the winter months.
- c. Turbulence. Stream flow turbulence in the form of high current velocities, eddies, boils, etc. may be encountered on most streams under certain conditions. These flow parameters are more typically associated with moderate to high river stages during periods of flooding, or during other episodal events such as reservoir drawdown. As described previously, areas of turbulence normally contain aerated water which can scatter or absorb the transmitted or reflected acoustic energy. Although some degree of turbulent flow will probably always be present in riverine environments, there are usually periods where conditions are more favorable for the acquisition of acoustic data. Summer and fall are normally characterized by lower stages and current velocities that provide more favorable water surface conditions for acoustic profiling.
- d. Debris. Surface or near-surface debris located in the stream channel can hamper or cancel acoustic profiling operations. The most common type of debris encountered on rivers is floating or submerged wood, ranging from small limbs to large intact trees. This material is normally introduced into the stream system during increases in river stage. Driftwood can damage not only towed acoustic equipment, but the survey boat as well if the debris is large and heavy. More commonly, however, small pieces of debris attach and clog towed components of the profiling system, resulting in a loss of hydrodynamic towing characteristics normally causing a loss or reduction in component performance. Floating debris is generally at minimal levels during periods of falling river stages.

#### Meteorological parameters

40. Wind. The effect of wind on water surface conditions has already been discussed in the preceding paragraphs. Wind is probably



the most important meteorological parameter affecting acoustic profiling operations since it affects the operation in several significant ways. Rough water not only creates discomfort and difficult conditions aboard the survey boat, but causes an increase in background noise and system operational problems created by the wave action. Together, these factors usually cause a reduction in acoustic record quality.

41. Rain. Although moderate to heavy rain can hamper acoustic survey operations, surveys can usually be conducted under such conditions if proper precautions are taken throughout the operation. Since most equipment must be installed in a weather-tight cabin, only those components, i.e., portable power generators, some types of power supply and capacitor bank components, etc., that must be operated outside of the cabin are subjected to weather variance. These units cannot operate during periods of rain unless protected in some manner. Even then, high moisture levels normally prevail and moisture can usually get into a critical part of the component, causing a malfunction. Periods of moderate to heavy rain can also affect safe navigation of the survey vessel. Navigation problems can be particularly critical on heavily used waterways.

42. Fog. On certain waterways fog can be a persistent and critical problem to the safe conduct and timely completion of acoustic profiling surveys. This weather phenomenon can occur at any time of the year along most waterways within the United States. Profiling operations should not be attempted during periods of moderate to heavy fog even if the survey boat is equipped with a radar navigation system.

43. Temperature. Air temperature extremes can seriously affect the operational performance and durability of most electronic components used in acoustic profiling equipment. Low temperature extremes can result in loss of system performance, but are not encountered as commonly as are high temperature extremes, primarily because acoustic surveys are often conducted during warmer seasons. System components, even those constructed with solid-state parts, generate appreciable quantities of internal heat. When profiling equipment is operated in a high-temperature environment such as a nonair-conditioned survey boat,



excessively high temperatures can damage component parts, such as transistors, causing their failure. Air-conditioned survey vessels should be used if the survey operation is in a high-temperature area (over 80°F). An air-conditioned cabin will ensure much less equipment downtime and will increase personnel efficiency.

### Bottom and Subbottom Parameters Affecting the Profiling Method

#### Physical properties

44. Composition. The composition, or sediment type, of bottom and subbottom materials of riverine environments does not alone determine the penetration capabilities of CSRPs systems. Sediment type is important in other ways, such as reflectivity, which will be discussed later. Physical and acoustic properties contained within the sediment structure are more important than sediment type in affecting the capability of the transmitted acoustic energy to penetrate and detect interfaces within the sediment column. Sandy materials, for instance, should not be more difficult to penetrate than the fine-grained materials such as clay sediments, or vice versa. On the other hand, if there is a particular physical or acoustic property, or combination of properties (i.e., density, organic content, etc.), associated with one sediment type and absent in another, significant differences in penetration capabilities of CSRPs systems between the two sediment types can occur.

45. Side-scanning sonar can often detect differences in the materials composing the bottom. The most intense reflections are normally caused by topographic changes, but the more subtle changes in reflectivity can be due to variations in sediment type (Jenkinson 1977). Fine-grained materials normally reflect less energy and the coarser materials, such as gravel, rocks, and coarse sands, are generally much more efficient reflectors. These differences usually are portrayed on the record as lighter or darker areas and different textures.

46. Sediment density and porosity. Probably the most important physical properties of sediment structure affecting the CSRPs technique are density and porosity. Simply stated, most reflections on a CSRPs



record represent changes in density or porosity due to fundamental interactions of physical and acoustical properties within the sediment. Porosity may be related to sediment type only in very general terms, i.e., high porosity relates to silts and clays and low porosity to sands and gravels. Acoustic impedance, the product of the velocity of sound in the medium and the bulk density of the medium, is believed to bear an inverse relationship to porosity--high porosity sediments have a low acoustic impedance and conversely. As high porosity occurs with the fine-grain sediments and low porosity with the coarser sediments, it is generally said that clay is a bad reflector of acoustic energy and coarse sand a good reflector (Smith and Li 1966).

47. Grain size. Variation in sediment grain size appears to have an influence on the interaction of sediment and some acoustic properties. Acoustic impedance (reflectivity) and compressional velocity generally decrease gradually as grain size decreases. There also appears to be a corresponding increase in sediment porosity as grain size decreases. Thus, fine-grained sediments may attenuate acoustic energy to a lesser degree than is the case with coarser sediments. For this reason, acoustic energy generally penetrates clay and silt deposits more easily and deeply than it can penetrate sand or gravel.

48. Other physical properties. There is one important exception to the supposition that fine-grain, highly porous sediments are most readily penetrated by acoustic energy. When air or gas bubbles, derived from decaying organic material, pollution, etc., are trapped in pore spaces within the sediment column, they effectively attenuate and reflect acoustic energy. The degree of attenuation and reflection is somewhat dependent upon the mass of the gas trapped in the near-surface sediments. Although deposits characteristically containing areas of gaseous sediments are more common within shallow-water, coastal environments and inland lake environments, polluted or organic deposits have also been encountered in riverine environments.

49. Other acoustically turbid zones within natural streams and waterways can result from the activities of man. Acoustic profiles over areas of the stream bottom recently disturbed by activities such as



dredging may be characterized by the lack of penetration into the sub-bottom due to the presence of air entrapped in the bottom sediments. This situation is due primarily to the aerating action that dredging has on the upper few feet of the sediment column.

50. Dredged spoil material removed from one reach of a river and deposited in another area of the river can also effectively retard penetration of acoustic energy because the spoil material contains large amounts of air bubbles. This situation is normally temporary, since active stream processes will rework the material in a short period of time.

#### Acoustic properties

51. Reflectivity and acoustic impedance. Reflected acoustic energy from bottom and subbottom boundaries is a function of the reflectivity, or reflection coefficient, of the sediments. As previously stated, sediment type, while important as a factor in the reflection process, is not singularly responsible for reflection of acoustic energy. Acoustic reflections can occur within a homogeneous sediment body. It is the boundaries within the sediment body, separating two media of contrasting properties, that are significant. In most cases these boundaries do coincide with lithologic or facies changes either laterally or with depth, in the subsurface. However, the most significant property is the acoustic impedance. Although acoustic impedance is roughly related to the sediment or rock type, it more closely correlates with the porosity (Smith and Li 1966). Thus, the amplitude of the acoustic energy reflected from bottom and subbottom environments is a function of the acoustic impedance of the reflecting interface between two contrasting lithologic units. For example, a clay layer and sand layer having contrasting levels of acoustic impedance caused by differences in porosity should produce a strong reflection at the clay-sand boundary. It follows then that a change in acoustic impedance is more important in the reflection process than a change in lithology. This fundamental premise in the profiling technique should not be forgotten during data interpretation phases.

52. Acoustic velocity. The accurate interpretation of acoustic profile data requires knowledge of the acoustic compressional velocity



in sediments and rock. Since the acoustic record is nothing more than a display of energy travel time, an internal or average velocity for the sediment column must be assumed or measured to estimate sediment thickness or depth to various reflectors. Some attempts have been made to correlate compressional velocities with grain-size for the analyses of the relationship between attenuation and frequency and other physical properties, such as porosity and density. One study indicated that average velocities obtained from in-situ measurements of seafloor sediments ranged from about 4700 fps for clayey silt up to 6000 fps for coarse sand (Hamilton 1972). Nearly all acoustic profiling system recorders are calibrated for an assumed speed of sound in water of approximately 4800 fps. The velocity in unconsolidated sediments, particularly those in the near-surface, is commonly assumed nearly equal to that of water, but as sediments become increasingly more consolidated (usually with depth), acoustic velocities increase.

53. Attenuation. As acoustic energy is propagated through the media, certain properties of the energy and sediments interact to attenuate the energy propagation. Studies concerned with the attenuation of sound in sediments have generally revealed a strong relationship between energy attenuation and the frequency of the transmitted pulse (Hamilton 1972, Tullos and Reid 1969). Some experimental measurements of attenuation and frequency dependence are shown in Figure 17. Attenuation loss is believed to be primarily due to two factors: (a) absorption of the energy due to pore-water viscosity, and (b) friction between sediment particles caused by the compressional sound wave passing through the sediment (Clay and Medwin 1977).

#### Acoustic Profiling Support Requirements

##### Survey boat

54. Boats utilized in support of acoustic profiling operations can be placed in three categories: (a) optimum capability, (b) limited capability, and (c) no capability. The selection of the boat to be used in support of the acoustic profiling survey is an important



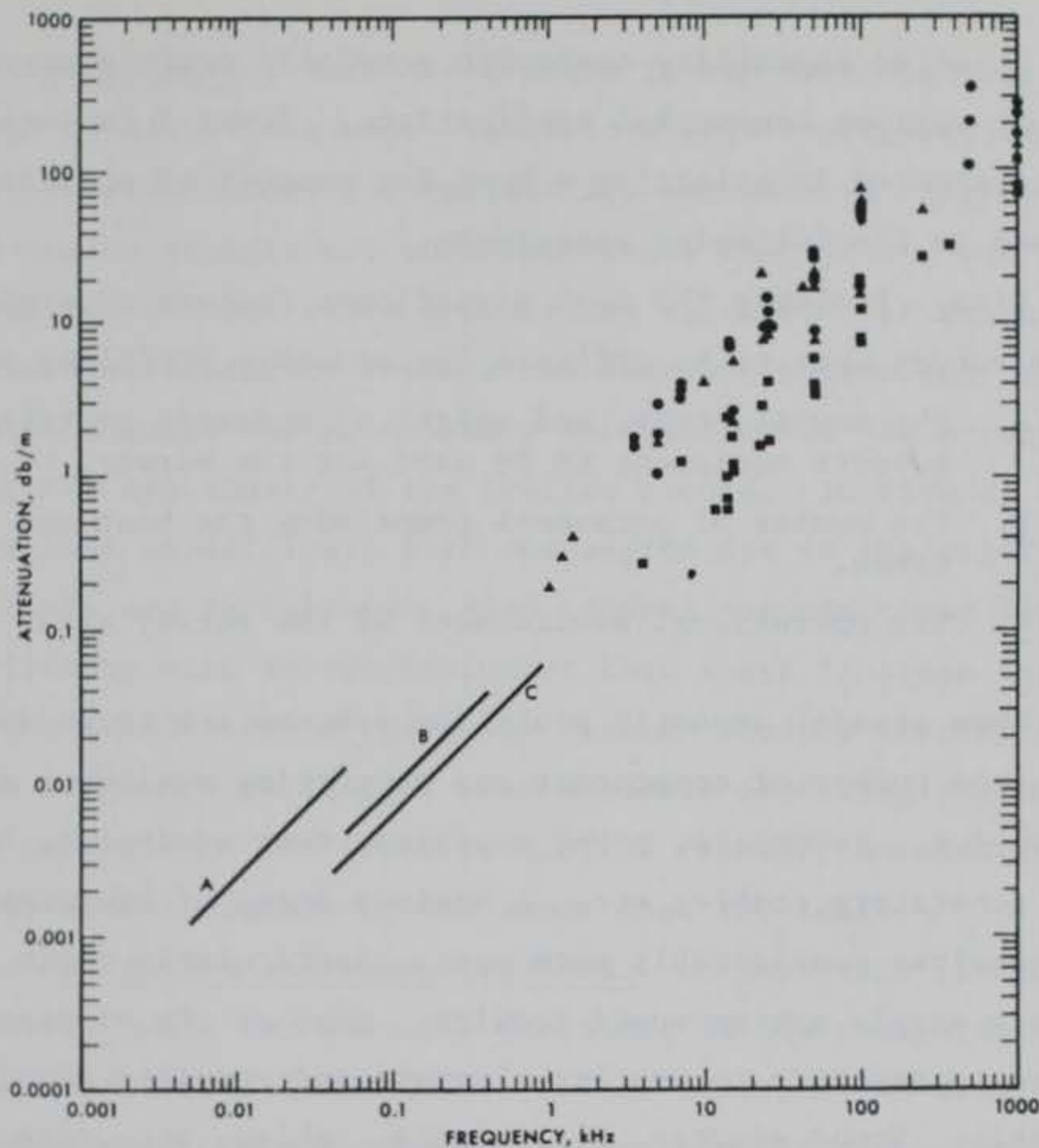

Figure 17. Attenuation versus frequency (The measurements are for natural saturated sediments and sedimentary strata: ●, sands (all grades); ■, clayey silt, silty clay; ▲, mixed sizes (e.g., silty sand, sandy silt, sand-silt-clay); sand data at 500 and 100 kHz. Low frequency data: line A land, sedimentary strata; line B Gulf of Mexico coastal clay-sand; line C sea floor, reflection technique; Hamilton, 1972.) (from Acoustical Oceanography, John Wiley and Sons)

decision. The optimum craft will be able to support a full array of equipment and survey personnel for an extended period of operations. Optimum capability boats are usually those that have been designed specifically for hydrographic or waterborne geophysical surveys. Limited capability boats are those not designed for waterborne geophysical or hydrographic surveying, but which can support a limited acoustic profiling survey for short periods of time. These boats are normally those used because they represent the only boats available in the survey area



or nearby. Limited capability boats are generally craft designed for recreation or various commercial applications. Several factors that should be considered in selecting a boat for support of acoustic surveys are discussed in the following paragraphs.

55. Size. Probably the most significant factors governing the size of the survey boat to be utilized for acoustic profiling are:

- a. The number, type, and weight of acoustic profiling and support equipment to be used for the survey.
- b. The number of personnel comprising the boat and survey crews.
- c. The operational environment of the survey area.

56. When several acoustic profiling systems are to be used in the survey, the number of components and supporting equipment can be quite large--i.e., recorders, power supplies, test equipment, hoisting equipment, generators, cable, etc. A maximum array of equipment and personnel requires considerably more space, particularly cabin and deck space, than a single system would require. Most of the electronic gear is sensitive to exposure to weather elements and requires housing inside the boat cabin. Sound sources, hydrophones, cables, etc., can normally remain on deck throughout the survey. Personnel requirements can vary somewhat, depending on the objectives of the survey, but normally include a boat operator, deck hand, system operators, electronic technicians, and an observer.

57. The environment of the survey area must be carefully considered. For example, will the size and draft of the vessel be appropriate for existing water depths and other hydrologic parameters in the survey area? Since rivers are generally characterized by variable water depths, the location and configuration of the survey area may be such that portions of the area can be negotiated only by boats whose draft does not exceed 3 or 4 ft. Based on experience gained in the course of this study and other surveys, it appears that boats ranging in length from about 35 to 65 ft with a maximum draft of about 4 ft are required for optimum support capability of acoustic operations on navigable rivers and waterways located in the United States.



58. Propulsion. Nearly all boats in the 35 ft or over size class are powered by diesel engines. The twin-diesel configuration is favored in view of considerations for reliability and safety. Engine failure in single-engine vessels not only interrupts the survey, but under certain circumstances can create a hazardous situation for vessel and crew. Twin-engine powered survey vessels can lose one engine and continue survey operations until the point where termination of the survey line would not affect the continuity of the profile record. In rivers, control of the survey boat is difficult with one engine due to the vagaries of river currents and turbulence. Also, diesel engines cause less electrical interference with survey equipment than spark ignition engines. The ignition characteristics of gasoline engines produce electrical signals similar in frequency to that of some acoustic profiling systems, creating noise patterns on the acoustic profile record. An additional factor in favor of diesel engines is the lower cost for fuel.

59. Navigation and communications. An important factor in selection of survey boats for acoustic profiling is the navigation and communication capability of the boat. A well-equipped, maximum capability survey boat should contain adequate navigation and communication equipment to ensure efficient and safe boat operational control under widely varying environmental and operational conditions. Minimum navigation/communication equipment requirements for acoustic profiling surveys should include: (a) compass, (b) radio equipment that will allow ship-to-ship and ship-to-shore communications, (c) navigation radar, (d) survey fathometer, (e) intercom system between pilot house and other compartments of the boat, particularly the equipment cabin, (f) a loud horn, and (g) required navigation lights.

60. Operating personnel. Every attempt should be made to ensure that the survey boat has a capable, experienced operator to pilot the boat. A boat operator can literally "make or break" an acoustic profiling survey. Acoustic profiling surveys are difficult even for experienced boat pilots because a high degree of proficiency in controlling the track and speed of the boat must be maintained. This requirement is increased in most fluvial environments. Optimum capability boats normally



carry reliable operating crews because of designed application and operational characteristics. The use of limited capability boats may entail the use of a boat operator who has no previous experience in waterborne surveys. In many instances, a few days of practice and adjustment to the nature of the work assignment will enable an experienced operator to handle the boat in a reasonably satisfactory manner. Personnel in charge of the survey should strive to maintain the boat and personnel within reasonable operational safety boundaries. Operators of boats to be used in support of an acoustic profiling survey should have a current U. S. Coast Guard operator's license for the appropriate size and class of boat. The operator should also be licensed for the type of waters where the survey is to take place. In addition, boat operators should be familiar with the particular area of the river or waterway where the survey will be conducted.

61. Miscellaneous. Other equipment or facilities that are necessary features of survey vessels include adequate hoisting equipment, safety devices--i.e., rafts, buoy rings, fire extinguishers, and life lines--and onboard power supplies. The effort required to offload and onload acoustic profiling and supporting equipment can be minimized by the use of specially designed winches, booms, A-frames, etc. The employment and retrieval of system components can also be facilitated by the use of hoisting equipment. Before selection of the survey boat, it should be established whether the vessel contains the required safety equipment in accordance with U. S. Coast Guard regulations.

#### Positioning of acoustic survey lines

62. Acoustic profiling data are essentially meaningless unless the geographic position of the vessel can be accurately determined. Depending on the nature and objectives of the survey, there are various methodologies and an array of equipment that will normally satisfy the requirements for accurate horizontal control of acoustic profile lines. Simple, reconnaissance-type profiling operations may require only visual reference to landmarks located in the area surveyed. Surveys conducted for the acquisition of detailed data that will be utilized for complex geologic or engineering projects should be located as accurately as



possible. Basic positioning systems and techniques currently in use are briefly discussed below.

63. Nonline-of-sight and line-of-sight systems. The positioning systems most widely used by the Corps of Engineers for the horizontal control of hydrographic and geophysical survey lines are generally electronic distance-measuring equipment (DME) grouped into the categories of nonline-of-sight or line-of-sight (Hart and Downing 1977). Most line-of-sight systems, similar to the one shown in Figure 18, operate in the microwave frequency band. These systems are highly accurate but are limited to line-of-sight operation because of signal attenuation of physical objects and some meteorological conditions, i.e., trees, buildings, hills, and heavy rain. Nonline-of-sight systems operate in the radio frequency (RF) bands. The longer wavelengths of the RF signals provide greater range capability and are less susceptible to signal attenuation by physical objects and weather conditions.

64. Visual positioning systems. For support of infrequent, or limited application surveys, visual systems coupled with voice radio links to shore may be employed. However, this positioning technique is somewhat slow and generally dependent upon favorable weather conditions. In addition, numerous personnel are usually required, both on the survey boat and shore. The most widely used optical boat-positioning technique requires the establishment of two transit stations at known shore locations to permit both transit operators to have line-of-sight viewing of a selected operating area (Figure 19) (Hart and Downing 1977). By taking simultaneous sightings on the survey boat, the operators can determine the boat's position and correlate this with position fixes on the acoustic profile record. Several other variations of this positioning technique exist and are used by different groups.

65. Electronic positioning. Most electronic positioning systems depend upon the measurement of the time it takes energy to travel from a transmitter to a receiver. The transmitted energy must be in the form of either short pulses or continuous waves (cw). Some systems measure pulse-time difference; a second group of systems measure phase differences, and a few systems use a combination of both techniques



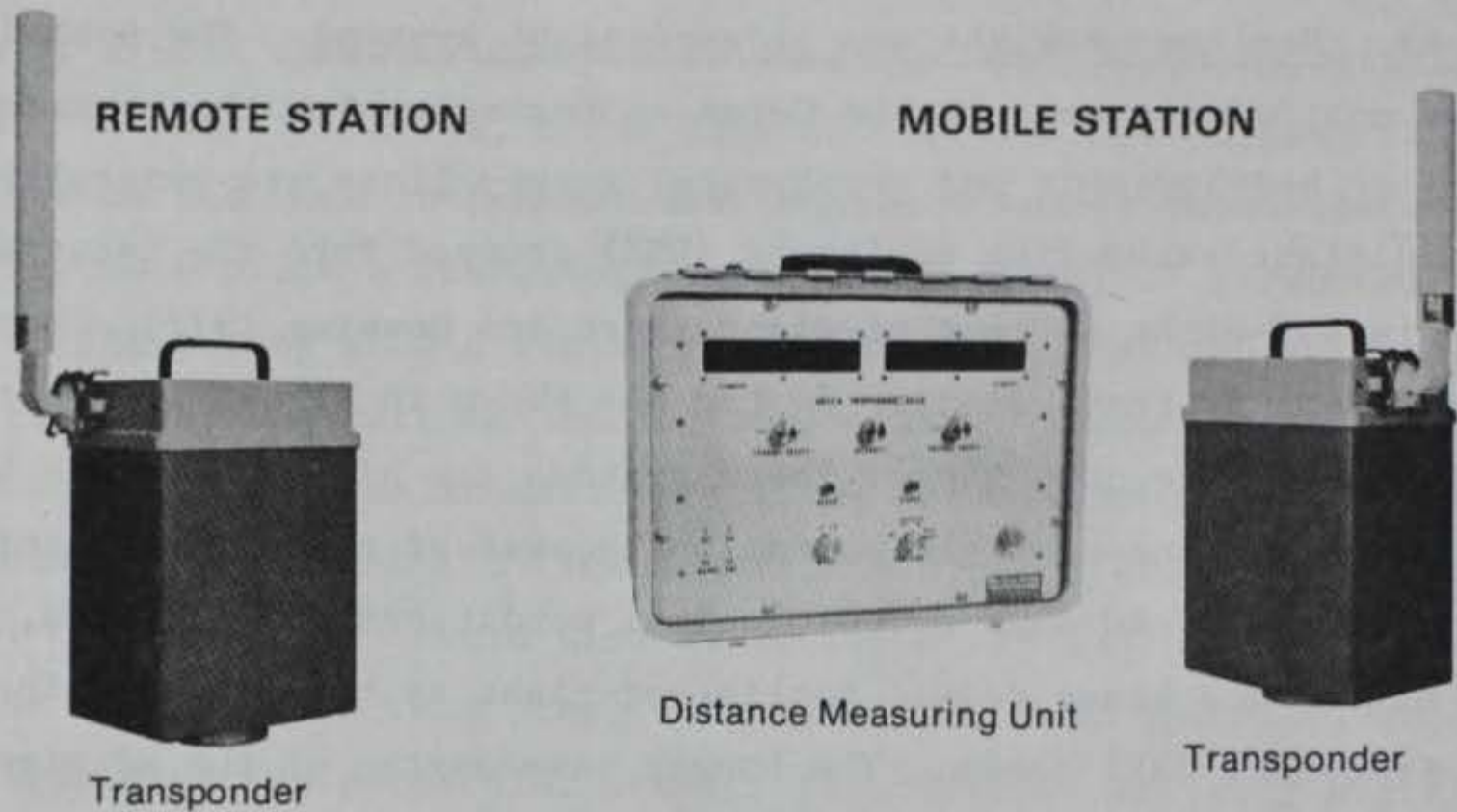

Figure 18. Major components of a typical microwave line-of-sight positioning system (courtesy of Del Norte Technology, Inc.)

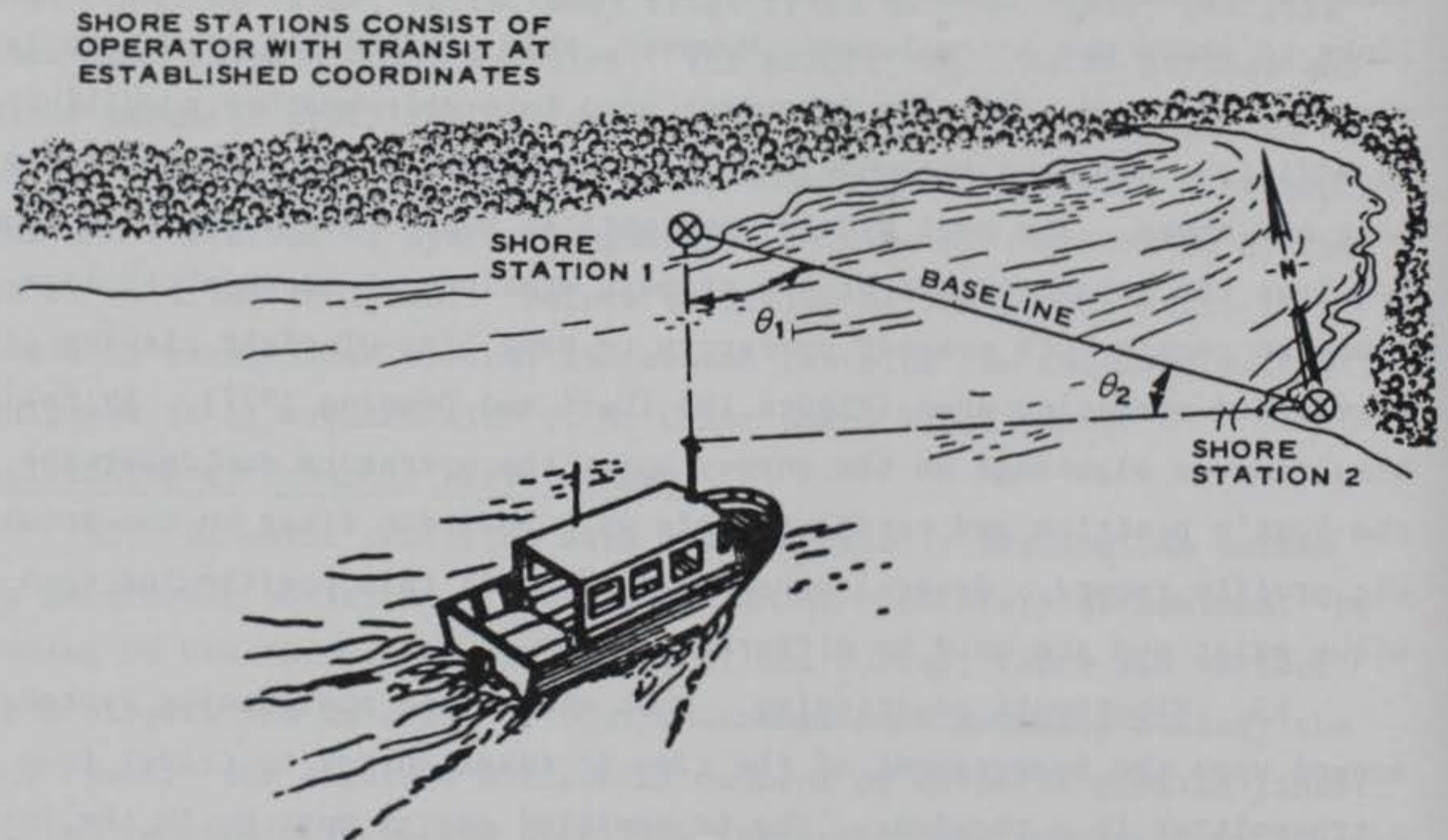

Figure 19. Visual horizontal positioning of survey boat (from Hart and Downing 1977)



(Cawley 1965). The choice of a system depends on a number of factors including range capability required, accuracy requirements, and cost. The use of most electronic positioning systems does increase the cost of the basic acoustic survey considerably, whether the service is contracted or whether an inhouse capability is used. The benefits of accurately located data usually offset the additional cost of positioning by a wide margin, however.

66. Electronic positioning techniques. Several relatively new positioning techniques use an array of electronic positioning equipment successfully developed during the past decade. The most commonly used techniques are briefly described in the following paragraphs:

- a. Range-range mode. The range-range positioning technique is the most commonly used mode for electronic positioning systems. The typical commercial range-range system determines the position of the survey vessel by measurement of distance from the survey boat to two or more known shore stations, as illustrated in Figure 20. The range-range technique normally involves the use of a mobile (master) transmitter/receiver (T/R) and two or more remote (slave) T/R stations. Pulsed transmissions from the master station, located on the survey boat, interrogate the remote stations; the remote stations respond, and the round-trip time is digitally measured and displayed by the distance measuring unit (DMU) of the master station, such as shown in Figure 21.
- b. Range-azimuth mode. The range-azimuth positioning technique, as shown in Figure 22, requires only one shore station compared to two for the range-range technique. Using range-azimuth positioning, the distance and angular departure from preplotted range lines can be determined. Procedures for using range-azimuth systems normally involve the installation of a remote T/R and an optical tracker at a survey control point on shore. A T/R and a DMU are located on the boat. Distances are determined on the boat by use of the DMU, and the azimuths are relayed by radio to the survey boat by personnel located at the shore station. This survey method is particularly useful in acoustic surveying conducted in riverine environments due to the meandering geometry of channels.
- c. Hyperbolic mode. Electronic positioning systems operating in the hyperbolic mode use a minimum of three shore stations and a receiver onboard the survey boat. The three shore stations generate a unique pattern of intersecting lines (Figure 23) that allows the survey boat position to



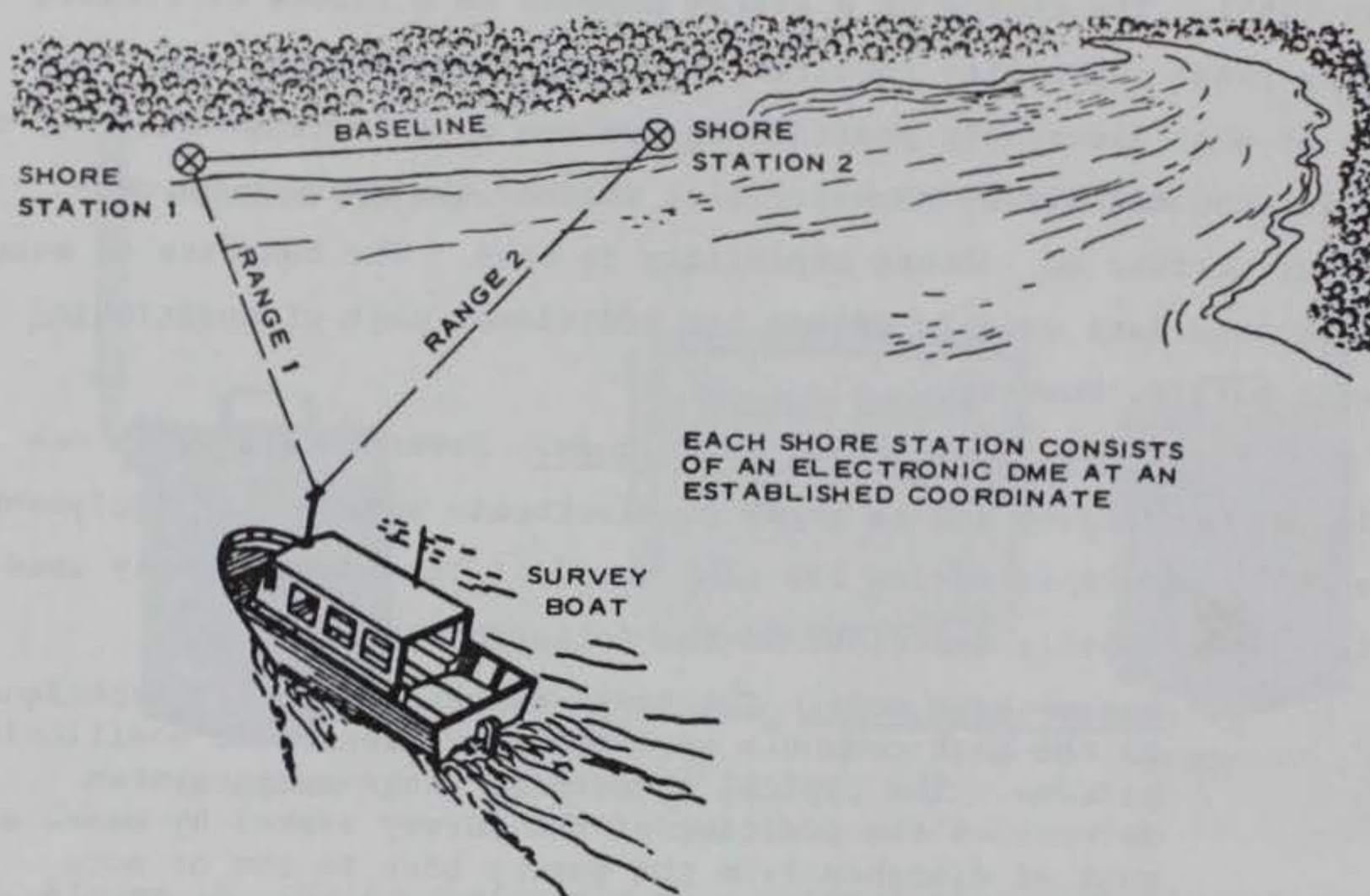

Figure 20. Range-range horizontal positioning of survey boat (from Hart and Downing 1977)



Figure 21. A two range configuration DMU (The unit provides visual readout of two ranges simultaneously one time per second; courtesy of Cubic Corporation.)



be calculated. Each hyperbola is a line of position. The receiver on the survey boat detects and compares the phase difference of the transmitted signals to determine the position of the survey boat. Hyperbolic geometry positioning systems are probably best suited for acoustic surveys in offshore marine environments.

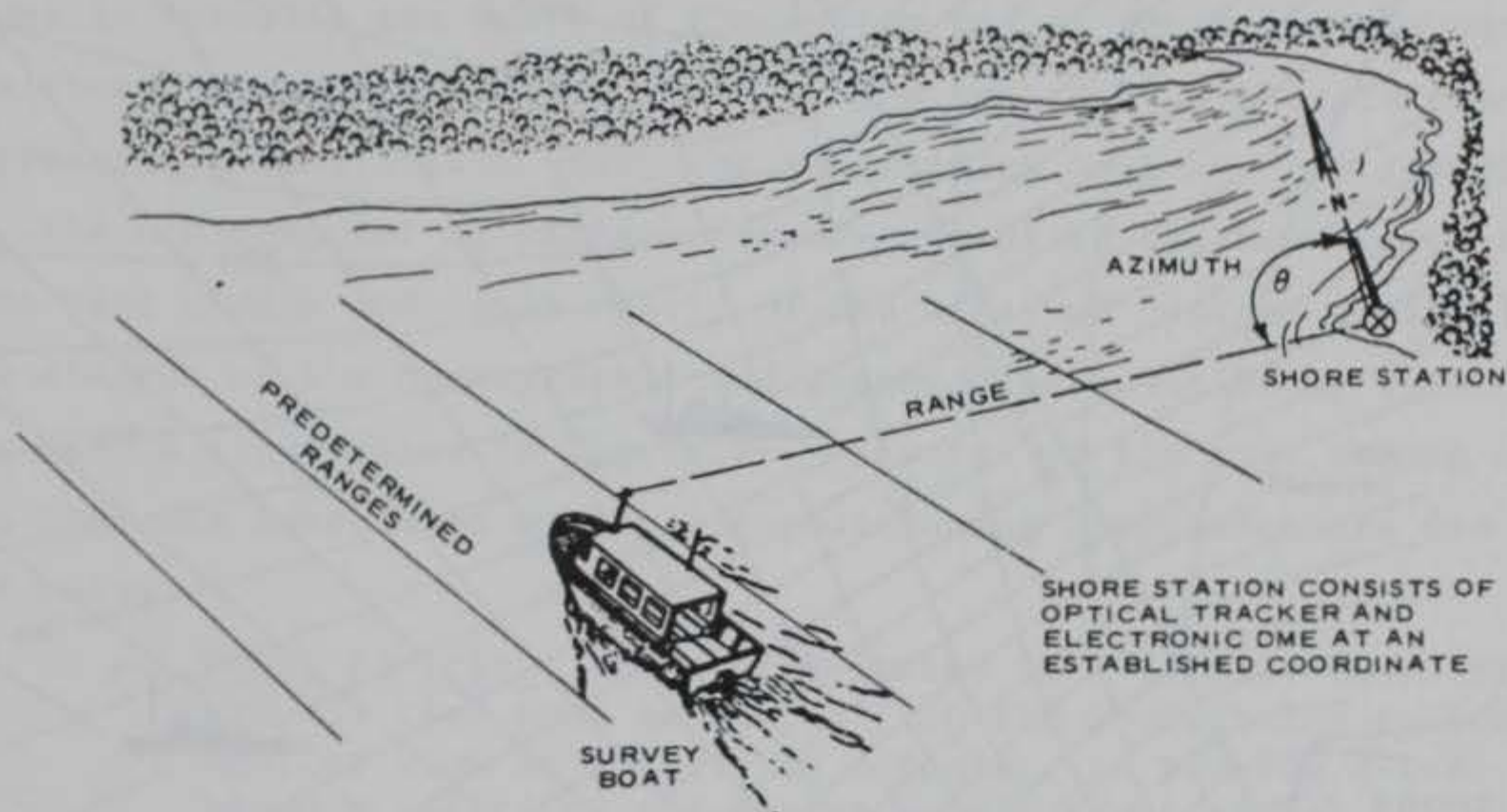

Figure 22. Range-azimuth positioning technique for horizontal control of survey boat (from Hart and Downing 1977)

67. Miscellaneous positioning systems. The foregoing paragraphs have briefly identified the most commonly used systems and techniques for the positioning of hydrographic and geophysical survey lines. There are other systems and techniques that deserve brief mention here. Although most of these systems represent relatively new technology and are still being developed to some degree, many are now in operational use. Examples of these systems include satellite, microwave and acoustic Doppler, laser, and optical positioning systems.

68. Expansion of the basic positioning system. Currently ancillary equipment designed to operate with the basic positioning system is currently available for the purpose of conducting waterborne surveys in a semiautomatic or completely automatic mode. The basic location equipment can be expanded into a real-time data acquisition and processing system with little effort, but with considerable expense. An expanded capability, for example, would provide for automatic fix position



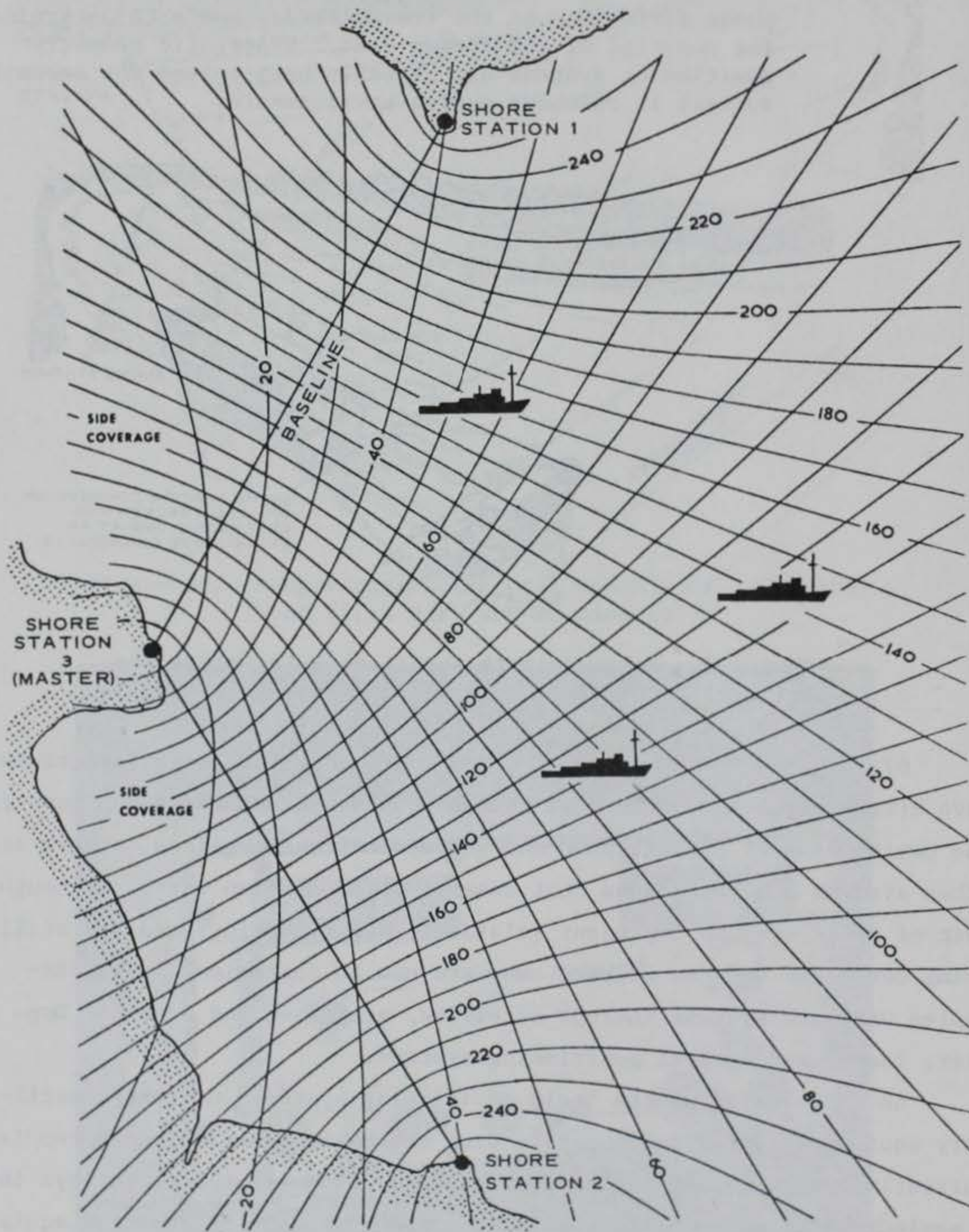

Figure 23. Line pattern generated by positioning system utilizing the hyperbolic mode (from Hart and Downing 1977)



marking and logging, survey boat guidance along preplotted survey lines, and logging of data on magnetic tape for subsequent processing. The state-of-the-art data acquisition and processing hydrographic survey systems available at the present time are normally controlled by either a computer or microprocessor or contain a data logger. The computer component is normally the heart of the system and is generally the mini-type, although some large survey vessels have much more elaborate computer processing facilities. But, for the smaller boat and the riverine survey, the minicomputer or microprocessor-controlled systems are probably the best choice and least costly of the array of systems available. A block diagram of the hydrographic and geophysical positioning system used by WES is illustrated in Figure 24. Several of the most common components that are interfaced with basic positioning components are described below:

- a. Track plotter. The track plotter is a display unit (Figure 25) that uses an output from the positioning system DMU, or from an interfaced computer, to provide a continuous record of the survey boat's track either in relation to preplotted survey lines, or in the absence of preplots, a record of profile lines run during the survey. Typically, the area to be surveyed is studied in advance and a layout of profile lines is programmed to meet the survey objectives. These survey lines can be preplotted on the track plotter chart. By maintaining the pen or stylus of the track plotter centered along the preplotted survey lines, the boat operator can keep the survey boat on a precise course.
- b. Computer/microprocessor. A wide range of computer, microprocessor, and data logger equipment has been developed for integration with other hydrographic survey components. The computer allows the programming of a multitude of survey functions, but basically programs survey lines and calculates survey coordinates (usually X/Y values). Most firms marketing the data acquisition and processing systems for interfacing with basic positioning systems offer a number of programs that can be used for hydrographic and geophysical surveying. The programs are usually set up so that simple "YES" and "NO" answers by the system operator to specific questions asked by the computer enable the operator to establish the data input for each survey line and make any changes necessary in the original program data. To compute the survey line data, the computer normally accepts certain basic data which may be



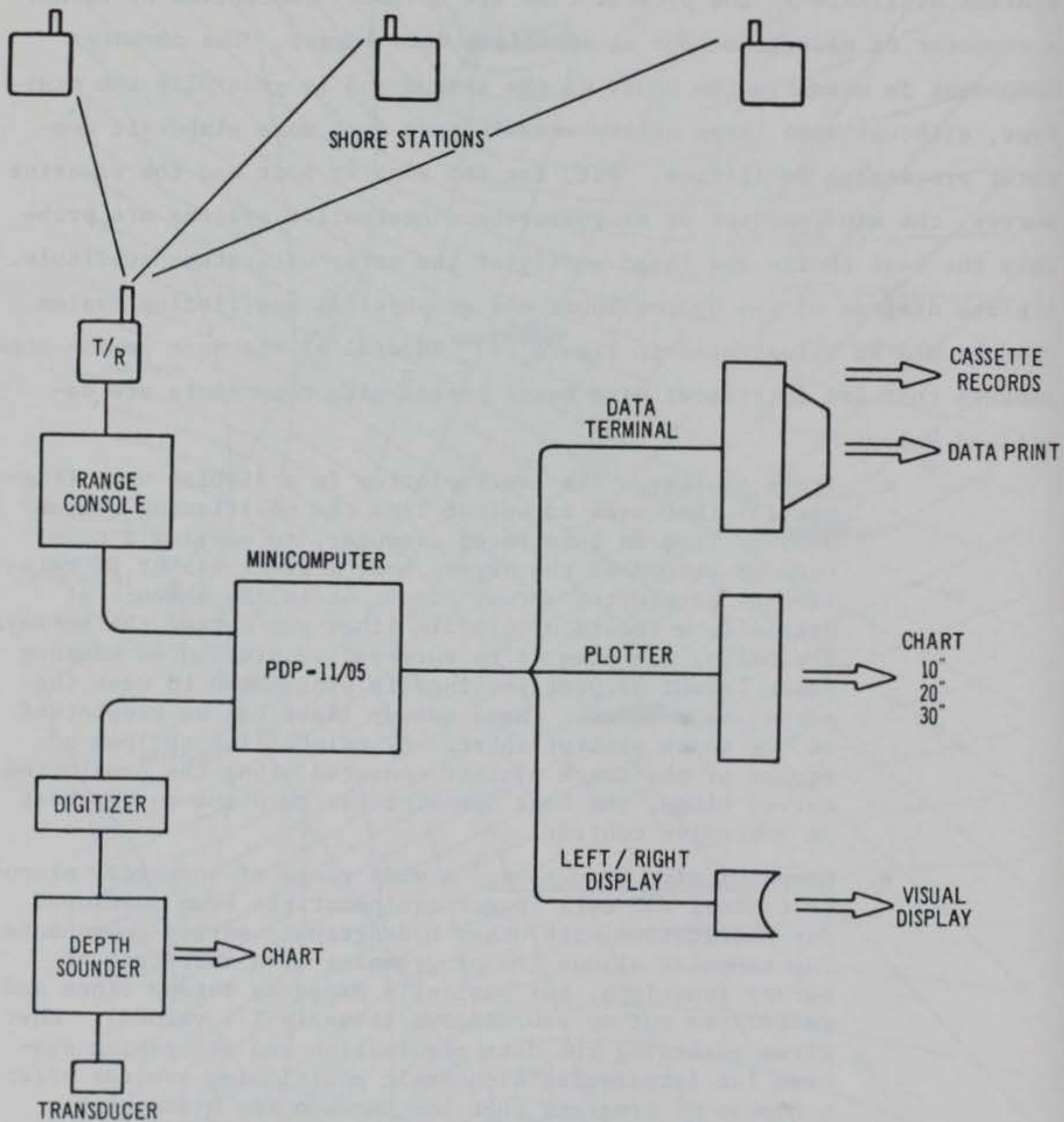

Figure 24. Components, functions, and interfacing scheme of the Decca Surveys, Inc. Autocarta System



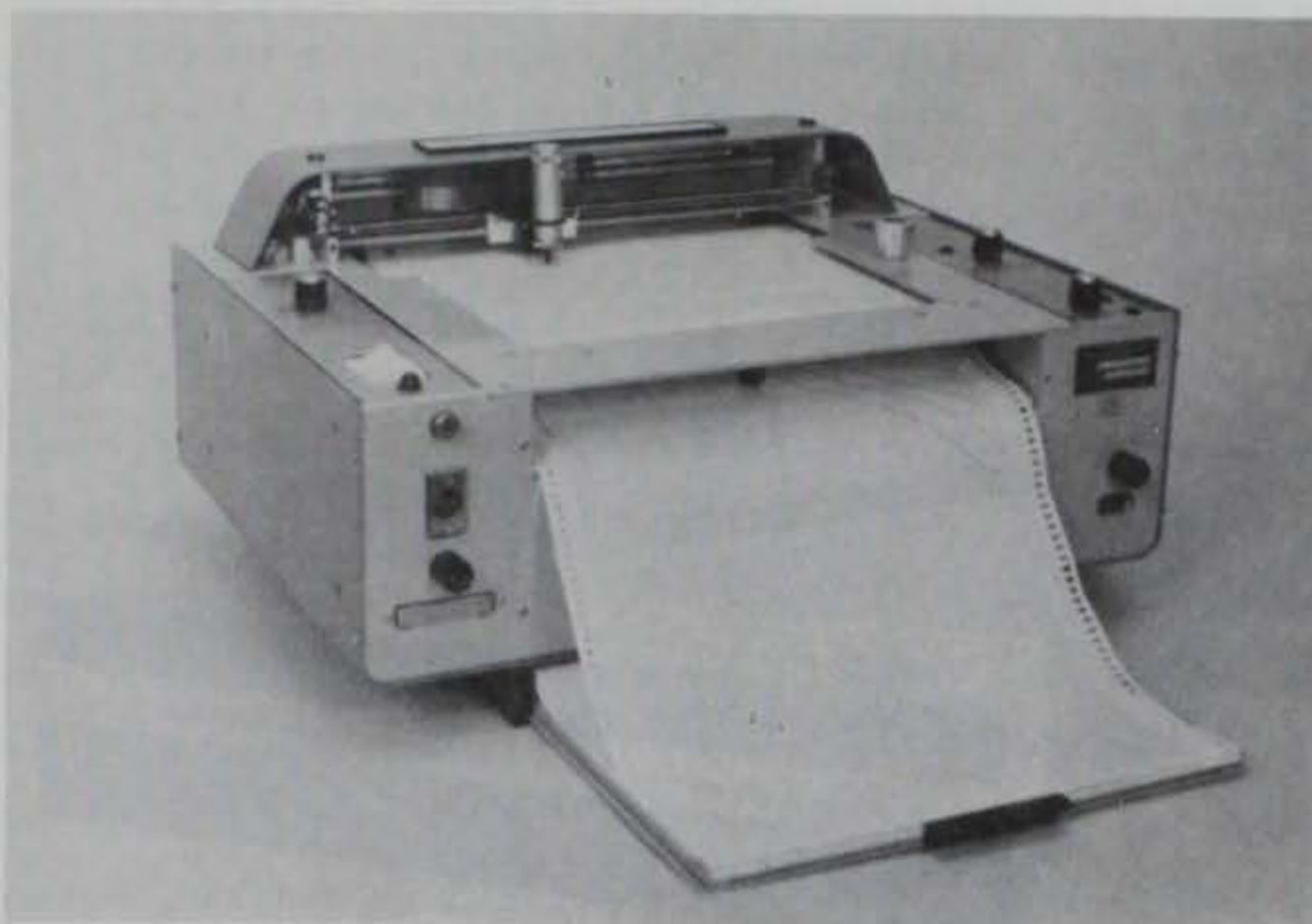

Figure 25. Houston Instruments plotter component of the WES Autocarta positioning system (This unit can be utilized for preplotting and postplotting of survey lines and for maintaining survey boat course during the survey.)

programmed in prior to the survey or programmed through the keyboard of a data terminal during the survey operations. This information usually includes coordinates of the shore stations, operating frequency, starting and ending coordinates of each survey line, grid scale, X and Y references, scale and distance between each position fix point. A minicomputer utilized in the WES positioning system is shown in Figure 26.

- c. Terminal/printer. The data terminal component (Figure 27) records and prints a hard copy of an array of survey data such as line number, DMU range figures, X/Y coordinates for each position fix, time of day at each fix, etc. (Figure 28). The data terminal normally has keyboard and magnetic tape capability, which allows programming of interfaced computer components either prior to or during the survey. The data terminal also records data on magnetic tape to provide a backup data storage capability and for subsequent postplotting or processing of positioning data.
- d. Left/right indicator. The left/right indicator is a simple device used as a steering aid for the boat operator. The component is designed to show a zero heading with





Figure 26. PDP-11 minicomputer component of WES Autocarta positioning system



Figure 27. Texas Instruments Silent 700 data terminal and printer component of the WES Autocarta system



left/right course deviations graduated in some unit of measurement, usually feet or metres. Input to the indicator is normally via the computer, or in some instances by the track plotter. Figure 29 shows a left/right indicator used with the WES Decca Autocarta System.

#### Bathymetric profiling equipment

69. The delineation of the bathymetry of the survey area is frequently a very important secondary requirement toward the fulfilment of survey objectives. Bathymetric data is relatively simple to obtain and usually represents minimal additional equipment and effort to obtain data that may prove to be extremely useful during subsequent acoustic data analysis. Bathymetric profiling systems can be interfaced with acoustic profiling systems so that simultaneous bottom and subbottom data is recorded, either as a split record or on separate records. Bathymetric profilers, commonly referred to as fathometers or echo sounders, continuously record the distance from the transducer face to the water bottom. In principle, the system produces an acoustic signal from a transducer installed in the hull of the survey boat, or towed alongside, which travels to the bottom and is reflected back to the transducer. The system measures the time lapse and converts the time interval into units of depth which are graphically displayed as illustrated in Figure 30. Bathymetric profiling systems of different types are used in various environmental conditions and can be classified by operating frequency. Each type is potentially best suited for certain operational parameters that may vary widely depending on the nature of the survey, the environment, and the objectives of the survey. The most widely used type of bathymetric profiler used in riverine environments is the high-frequency class. These systems range in operating frequency from 50 to 200 kHz generally and are characterized by narrow beam widths and provide high bottom resolution capabilities. Attenuation of acoustic energy is high at the highest frequencies, however. For this reason, some of the most recently developed echo sounders have a dual-frequency capability. The fathometer shown in Figure 31 is capable of operating at either 40 or 200 kHz.



LINE NO :1  
 START X :2489859.56  
 START Y :611147.14  
 END X :2493906  
 END Y :608565  
 FIRST FIX NO :1  
 FIX NO INCR. :1  
 LINE NO INCR. :1  
 LAST LINE NO :5  
 DX(LINE) :222  
 DY(LINE) :333  
 DATA OK? :Y

NO	P(1)	P(2)	X OR E	Y OR N	DEPTH	TIME	STNS
1	2863.00	5623.00	2489871	611165	0.0	100555	12
2	2919.00	5269.00	2490199	610930	0.0	100618	12
3	3001.00	4902.00	2490548	610716	0.0	100639	12
4	3148.00	4571.00	2490868	610493	0.0	100658	12
5	3335.00	4225.00	2491213	610269	0.0	100718	12
6	3527.00	3897.00	2491551	610077	0.0	100736	12
7	3803.00	3595.00	2491882	609830	0.0	100757	12
8	4054.00	3284.00	2492235	609637	0.0	100816	12
9	4365.00	3030.00	2492565	609399	0.0	100836	12
10	4668.00	2793.00	2492904	609188	0.0	100857	12
11	4966.00	2579.00	2493249	608999	0.0	100917	12
12	5304.00	2443.00	2493582	608775	0.0	100938	12
13	5641.00	2353.00	2493922	608564	0.0	100959	12

END LINE NO- 1

13	5419.00	1949.00	2494122	608926	0.0	101146	12
12	5083.00	2059.00	2493792	609126	0.0	101216	12
11	4740.00	2237.00	2493450	609336	0.0	101248	12
10	4410.00	2475.00	2493103	609541	0.0	101319	12
9	4082.00	2737.00	2492767	609761	0.0	101354	12
8	3774.00	3030.00	2492432	609975	0.0	101429	12
7	3480.00	3335.00	2492106	610196	0.0	101503	12
6	3206.00	3672.00	2491765	610417	0.0	101540	12
5	2969.00	4021.00	2491425	610631	0.0	101615	12
4	2767.00	4370.00	2491094	610847	0.0	101651	12
3	2637.00	4738.00	2490747	611039	0.0	101725	12
2	2512.00	5098.00	2490421	611277	0.0	101758	12
1	2487.00	5474.00	2490078	611480	0.0	101833	12

END LINE NO- 2

1	2081.00	5320.00	2490317	611809	0.0	102032	12
2	2133.00	4937.00	2490655	611593	0.0	102052	12
3	2278.00	4565.00	2490981	611356	0.0	102111	12
4	2420.00	4189.00	2491328	611180	0.0	102130	12
5	2708.00	3835.00	2491640	610904	0.0	102151	12
6	2932.00	3464.00	2491993	610732	0.0	102214	12
7	3242.00	3130.00	2492310	610494	0.0	102236	12
8	3554.00	2785.00	2492653	610222	0.0	102301	12
9	3860.00	2442.00	2493009	610101	0.0	102324	12
10	4229.00	2152.00	2493346	609856	0.0	102346	12
11	4574.00	1896.00	2493682	609648	0.0	102410	12
12	4922.00	1696.00	2494014	609442	0.0	102432	12
13	5291.00	1554.00	2494370	609235	0.0	102457	12

END LINE NO- 3

Figure 28. Hard copy printout of several positioning parameters obtained by data terminal and printer component



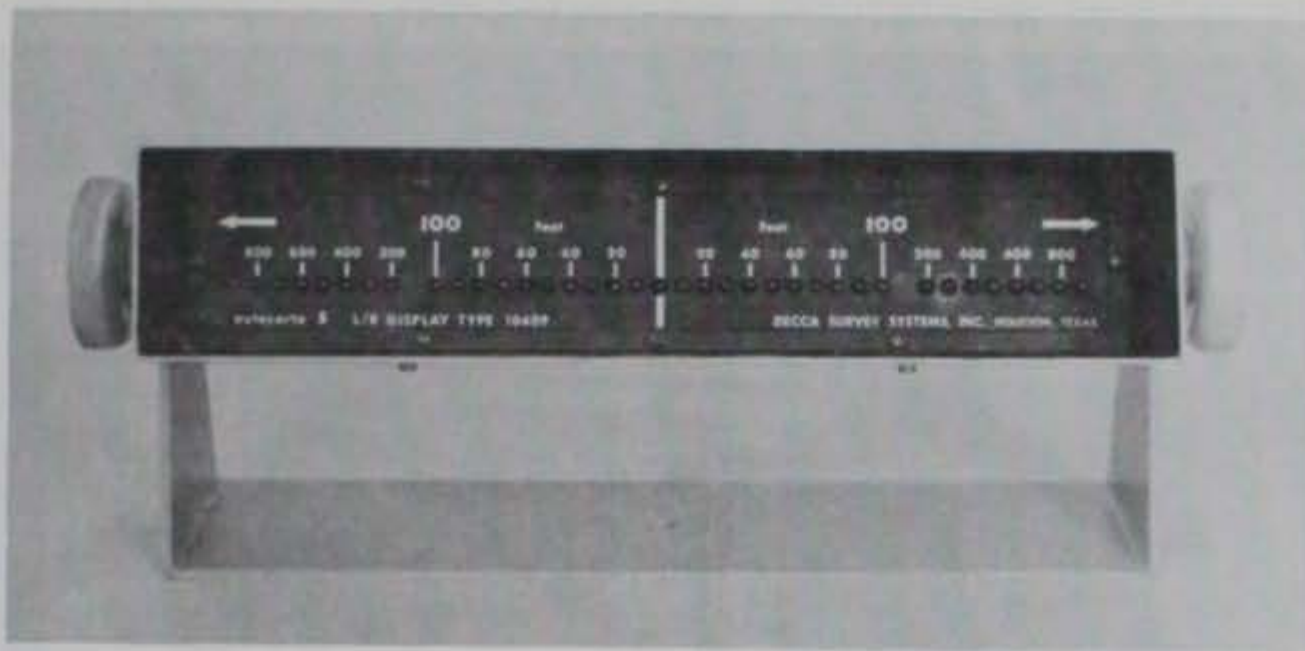

Figure 29. A left/right display designed to aid survey boat operator to keep boat on survey line (Lights indicate number of feet to left or right boat deviates from course.)

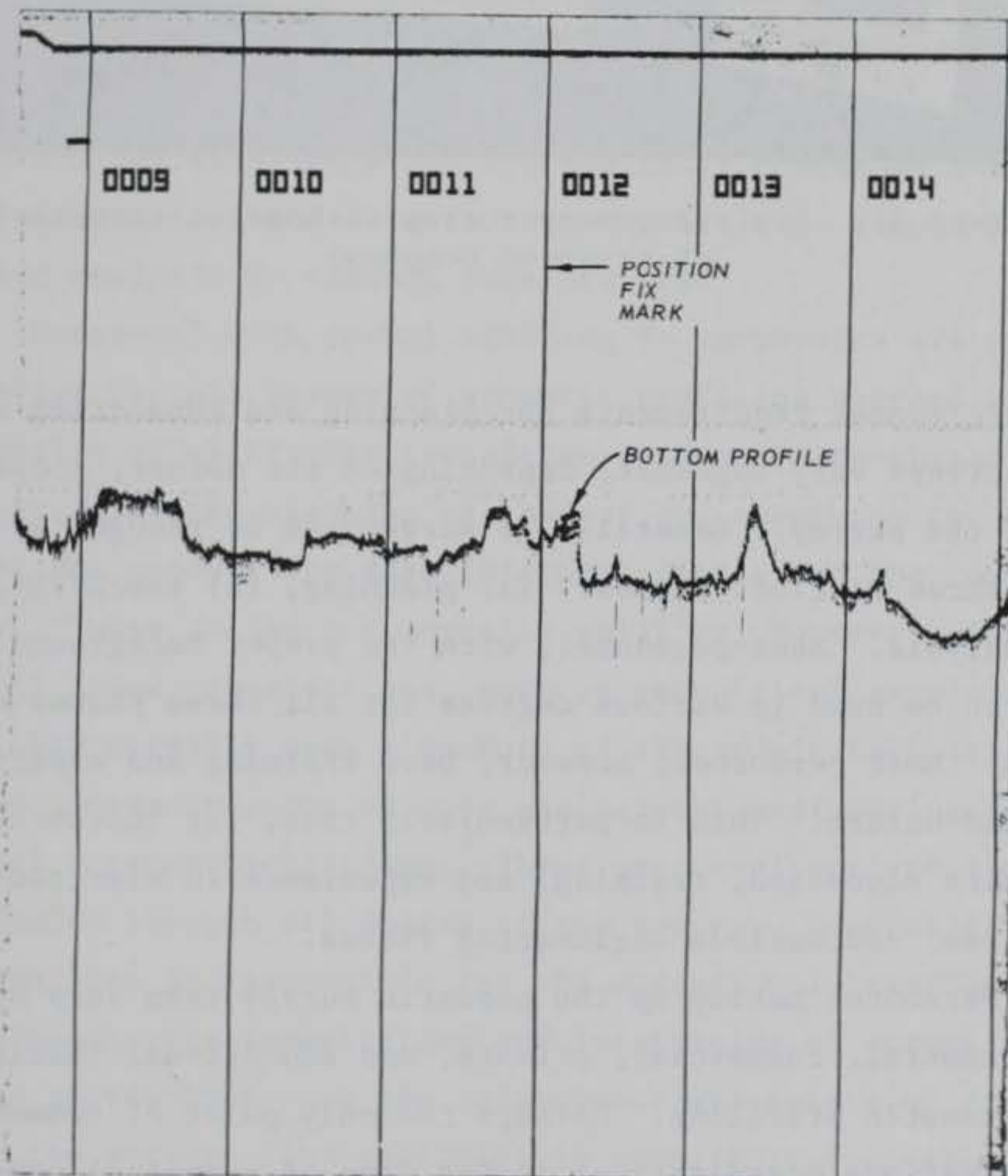

Figure 30. Chart profile record obtained with a bathymetric profiling system



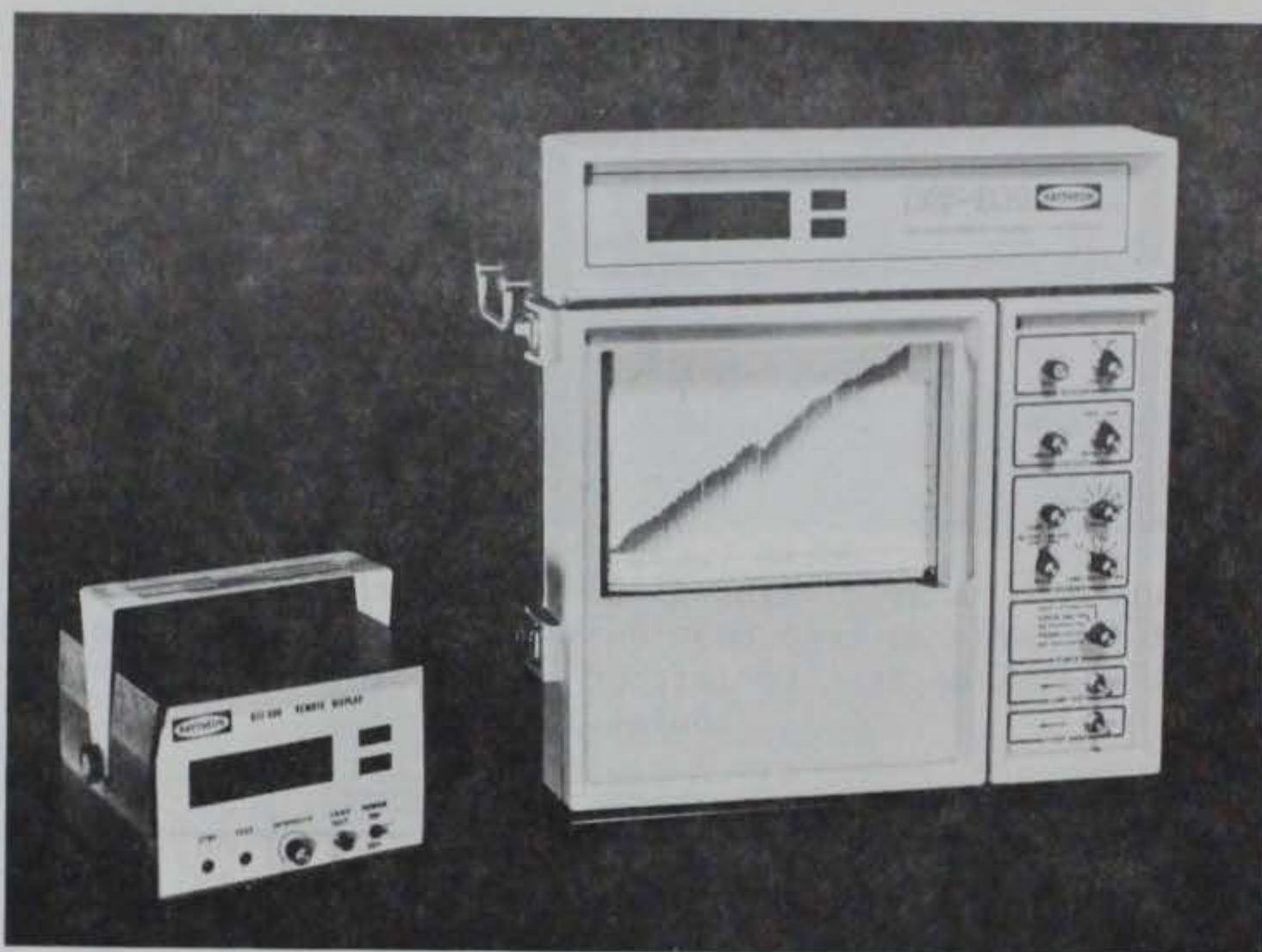

Figure 31. Dual-frequency survey fathometer (courtesy of Raytheon Company)

### Personnel

70. Personnel requirements for planning and conducting acoustic profiling surveys vary somewhat, depending on the nature, scope, and objectives of the survey. Generally, a survey can be thought of as consisting of three distinct phases: (a) planning, (b) execution, and (c) data analysis. Some personnel, with the proper background and experience, can be used to various degrees for all three phases of acoustic surveys. Most personnel, however, have training and experience of a specialized nature. This is particularly true, for instance, of personnel with education, training, and experience in electronics, earth sciences, and various engineering fields.

71. Personnel making up the acoustic survey team vary widely among governmental, commercial, private, and educational institutions active in acoustic profiling. Perhaps the only point of commonality among these various organizations in the type of personnel used is the use of electronic technicians. The survey team must contain one or more



personnel experienced in setting up and maintaining complex electronic equipment, ranging from simple electronic test equipment to complicated data processing components. Other personnel on the team may represent a wide field of experience and educational background. Generally, the objectives of the survey often dictate the type of personnel experience required in support of the survey. For instance, acoustic surveys conducted for the purpose of obtaining geological data of various types will normally have one or more geologists as members of the team to ensure that the data being acquired is in keeping with the objectives of the survey. Surveys concerned with delineation of competent subsurface formations for use as foundations for offshore structures might use personnel trained in engineering or engineering geology. Some organizations, particularly those who principally conduct various types of geophysical surveys for clients, use personnel with little or no background in earth sciences or geophysics. However, these personnel usually have many years of practical experience and are generally concerned with the collection of good data. The data is then forwarded to company offices for the detailed analysis by trained interpreters.

72. Personnel with formal training in geophysics are probably best qualified for all phases of acoustic profiling surveys with the possible exception of electronic technician duties. A geophysicist can normally carry out the planning of the survey, supervise the conduct of the survey, and conduct the data interpretation after the completion of the survey. These duties are normally split up, however, within the framework of large organizations, such as geophysical service companies.

73. WES normally uses a mixture of electronic technicians, both inhouse and contracted; one or more geologists; engineering technicians; and physical science technicians. These personnel perform a wide-ranging scope of duties through all phases of the survey. Generally, the electronic technician is responsible for the operational readiness of all survey equipment; the installation and interfacing of survey systems onboard the survey boat; and the maintenance and safety of systems throughout the survey. The geologist is normally responsible for the overall conduct of the survey and subsequent data analysis. The



engineering and physical science technicians normally operate and monitor various survey components, such as graphic and magnetic tape recorders and DMU's. However, a great deal of flexibility is generally found in duties performed among the personnel composing the survey team. Probably the greatest asset for personnel engaged in acoustic profiling surveys is experience, because of the unique and demanding nature of waterborne surveys and the complex array of survey systems and supporting equipment required for optimum survey results.

#### Electronic test equipment

74. Because nearly all acoustic profiling systems are composed of complex electronic and electromechanical components, an adequate array of electronic test equipment should be included in the survey equipment inventory. Test equipment such as oscilloscopes, volt-ohm meters, and signal generators are essential for monitoring and repairing of survey electronic equipment in the event of malfunctions.

#### Bottom and subbottom sampling

75. A dual program of acoustic profiling and physical sampling is usually necessary to obtain maximum subsurface information and to satisfy most survey objectives. Although experienced data interpreters can normally extract a certain amount of lithologic and stratigraphic data from the acoustic records, correlation of the acoustic data with that of sediment and rock samples obtained in the survey area should be accomplished if possible. Sampling can be accomplished before, during, or after the survey. Most CSRP users prefer to delay sampling until they have had an opportunity to review the acoustic records. This approach allows the selection of points along the profile lines where optimum correlation of data can be accomplished. If possible, random, indiscriminate sampling should be avoided. Ideally, sample point locations should be situated as close as possible to position fixes along the survey profile. The same type of positioning system used during the acoustic survey should be used for the location of points selected for sampling. The number of sampling points is directly related to several factors, among which are: (a) size of the survey area, (b) objectives of the survey, (c) availability of previously documented subsurface information,



and (d) funding available for sampling program.

76. Water-covered environments generally present many more problems for the acquisition of material samples. In fluvial environments, current velocities are probably the most important factor affecting the procedures used in obtaining bottom and subbottom samples. Special equipment and platforms must be used in most cases, and these factors usually increase the cost of sampling significantly. If possible, boring logs or samples obtained within the survey area and adjoining areas as a result of previous projects and investigations should be obtained to complement a new sampling program. In some instances, these sources of samples may be all that is available to the investigation if time or funding constraints prevent the initiation of a sampling program.

#### Sampling equipment

77. Bottom samplers. There are three general methods for the collection of bottom samples: (a) coring, (b) dredging, and (c) grab sampling. Each has advantages and limitations, depending upon the type of investigation, nature of the bottom, water depth, and equipment required for the deployment of the samplers. The small, snapper grab samplers have been used extensively for shallow-water bottom sediment sampling. These samplers are relatively light, easy to operate (they can normally be lowered and raised manually), simple mechanically, and require little or no maintenance. Bottom penetration is limited to a few inches. The optimum application of this type of samplers would probably be during low water periods or in protected areas where current velocities are low.

78. Perhaps the most effective and least expensive means for obtaining bottom sediment samples in fluvial environments is through the use of a dredge, or scoop sampler. The Corps of Engineers employs this method, particularly along the Mississippi River, for bed material sampling. The sampler is normally a weighted device which is lowered and raised by a winch. The sampler is heavy enough (100 lb or more) so that stream currents do not prevent the device from reaching the bottom. One bottom sampler of this type used extensively by various U. S. government



agencies, including the Corps of Engineers, is the BM-54. The BM-54, a sampler designed by the U. S. Geological Survey, collects a bed material sample from the upper few inches of a river bed. The material to be sampled may be firm, soft, plastic, or granular (Guy and Norman 1970).

79. Subbottom samplers. Sediment sampling of the shallow subsurface (0- to 100-ft range) generally requires the use of either land drilling type equipment or coring equipment which can be set on the bottom and operated by remote control. Remote, gravity-type corers, although used extensively in offshore marine and inland lake environments, appear to be little used in riverine environments. Gravity corers are weighted tubes which are essentially driven into the bottom by the weight of the unit. The device is allowed to free-fall through the water column and is retrieved by a line attached to the top of the corer. Gravity-type corers could possibly be used successfully in riverine environments. However, favorable conditions, i.e., low current velocities, soft bottom sediments, etc., would be required to achieve consistent success.

80. Most commercial and governmental sampling projects use barge-mounted rotary drill rigs or vibratory coring rigs for acquisition of subsurface sediment samples in natural and artificial waterways. The Corps of Engineers uses contract or in-house drill rigs for sediment coring. When rotary and vibratory coring equipment are used, barges are anchored or stabilized by spuds. This method of operation is normally satisfactory in rivers, unless current velocities are unusually high.

81. Vibratory coring rigs may represent an alternate to rotary equipment for the expedient sampling of fluvial sediments. These corers are characterized by rapid acquisition of up to 40 ft of core, and are generally less expensive to use than conventional drilling methods. Penetration rate into the subsurface is variable, but rates as high as 1 fps in soft clays have been observed. The vibratory corer shown in Figure 32 is a type used by the Mobile Engineer District, Corps of Engineers. The corer uses a pneumatic impacting piston vibrator on top of a core pipe made of standard 4-in. steel pipe which is fitted with a 3.5-in. plastic liner to contain the core sample for ease of handling and



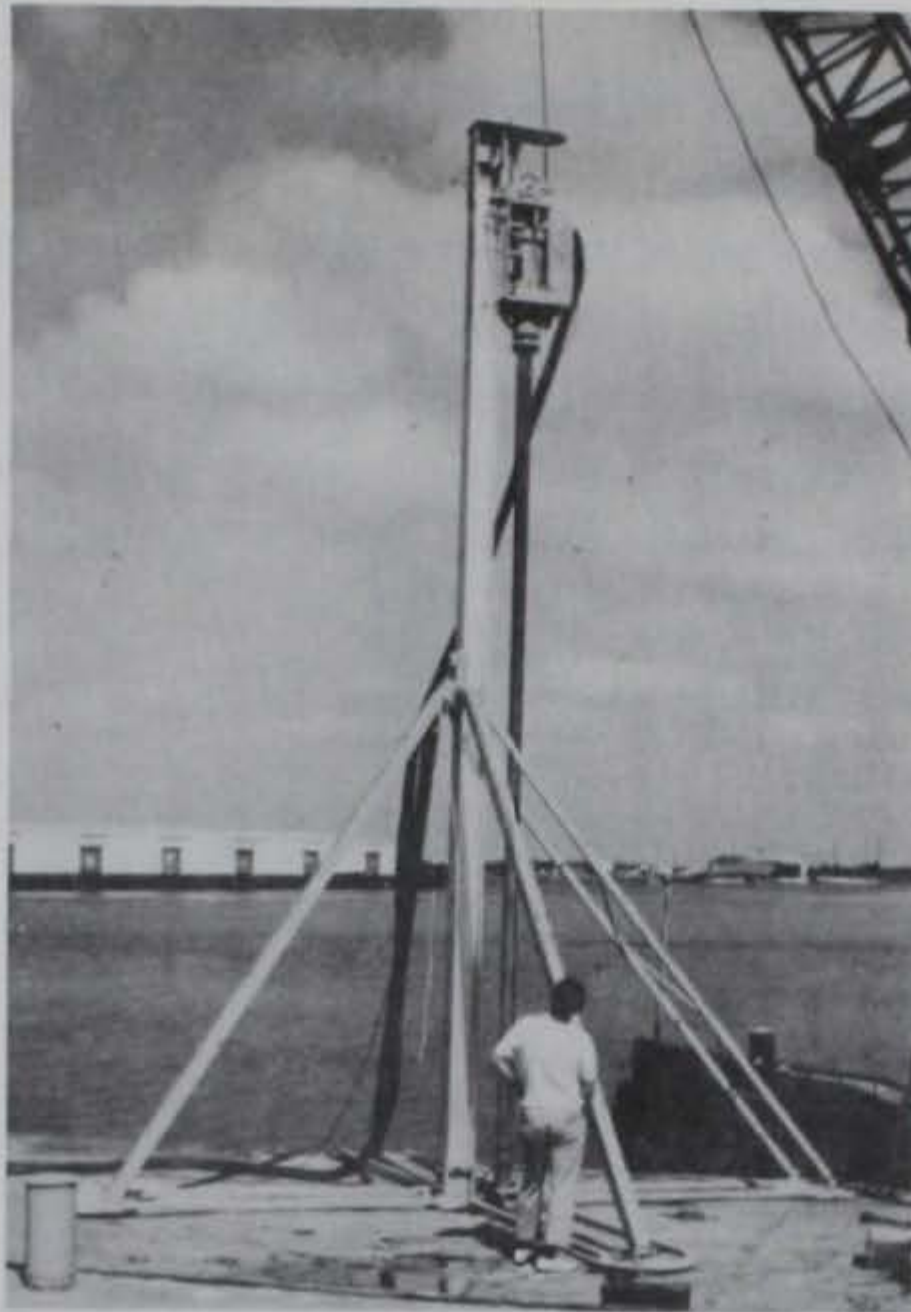

Figure 32. Vibratory sampler used by the Mobile Engineer District, Corps of Engineers (CE), for acquisition of 30-ft samples in support of a WES acoustic survey conducted in Mississippi Sound

storage. An aluminum H-beam, supported by 4 legs, is placed upon the water bottom where it serves as a support tower and guide for the vibrator and core pipe. An air compressor aboard the support vessel provides the driving air by means of a single wire-reinforced flexible hose. The unit is lowered to the water bottom by means of a crane or other hoisting apparatus. After the corer is placed on the bottom, air is delivered to the vibrator and coring begins. The sediment types that have proved most difficult for vibratory samplers are fine, highly compacted sands and extremely stiff clays. The materials that present the least resistance in vibratory sampling apparently are soft silts and clays. Coarse sand and gravel also reportedly core easily by the vibratory method, although penetration rates are not as high as for silts and clays.



Figure 33 shows a Corps of Engineers-owned vibratory sampler in action in a coastal bay environment.



Figure 33. Vibratory sampler on the bottom and coring in Mississippi Sound (Water depth is approximately 10 ft)



## PART III: PLANNING AND CONDUCTING ACOUSTIC SURVEYS

### Selection of Acoustic Profiling Systems

82. The principal types of operational acoustic profiling systems and related support equipment have been discussed in Part II of this report. It is difficult to state that any one system can achieve all designed operational specifications over a wide range of operational environments and survey applications. It is probably true that many acoustic profiling systems were not originally intended for use in the fluvial environment and have, therefore, certain design limitations. However, in most cases adequate data can be obtained if these limitations are recognized and the systems are applied in such a manner to minimize specific equipment limitations.

83. Although experience and communication with other users of acoustic profiling systems are valuable parameters in choosing an acoustic system(s) and planning an acoustic survey, a number of other factors can be weighed before selecting a survey system. These factors (Lowell and Dalton 1971) are:

- a. Efficiency of operation, i.e., system operational characteristics, to ensure as nearly as possible that the system has the potential to obtain acceptable levels of data.
- b. Simplicity of system operation. This is particularly important where field personnel have limited electronic expertise to effectively operate the more complex systems.
- c. Design integrity, i.e., systems for which maintenance is minimal and little or no calibration is required.
- d. Cost of systems. Although not the predominant criterion for selection, this, by necessity, must be considered.
- e. Compactness of design. Even on larger survey boats, numerous systems and related equipment and operating personnel can hamper the overall efficiency of a survey operation if consideration is not given to arrangement and dimension.
- f. Operational compatibility where multisystem surveys are anticipated. Operating frequencies, for example, can create interference among the survey systems if their



- frequency spectrums overlap and proper filtering, recorder keying, etc. are not provided for.
- g. System that produces graphic records in real time in order for the user to adjust the survey plan in the field on the basis of data being obtained as the survey progresses.
  - h. Minimum use of consumables (fuel, recorder paper, recorder belts, power, etc.) consistent with required results.
  - i. Mechanical reliability of the system over a wide range of environmental operational conditions.
  - j. The firm(s) which designed or manufactured the selected system(s). The reputation and experience of the firm within the acoustic equipment field as to dependable equipment, service after purchase, etc. should be considered.

#### Collection and Use of Background Data

84. Background data includes all physical, environmental, and cultural data governing the general area or site of a planned acoustic survey. The availability of each type of data may vary widely from one geographic area to another. Background data considered useful for the planning and conduct of acoustic profiling surveys include:

- a. Maps and charts.
- b. Photography and imagery (ground and aerial).
- c. Published documents and records.
- d. Logs of subsurface sediment and rock sampling programs.
- e. Geophysical survey records of previous land and water surveys in the vicinity.

85. Although it is beyond the scope of this report to discuss in detail all types of data that could be of possible use for planning and conducting acoustic profiling surveys, data types that are particularly relevant to acoustic survey operations are briefly described below.

#### Topographic maps

86. Map coverages at scales of 1:24,000 to 1:250,000 are generally the most usable scales and are readily available for most areas of the United States. The detail at which topographic, hydrologic, and cultural



information is generally portrayed on these maps lends itself to presurvey planning and for guidance during the actual survey. These maps are particularly useful in unfamiliar areas where surveys are to be conducted. They may represent the only source of information available within the survey area. Information contained on most large-scale topographic maps will normally provide significant data regarding the configuration of the survey area that is useful in selection of access routes, layout of survey profile lines, location of port facilities, and often the location of navigation hazards.

#### Geologic maps

87. Geologic maps normally depict conditions such as the surface and subsurface distribution of formations (rock and soil type), structure, and in some instances landforms. While these maps do not normally contain data related to occurrence and type of material composing subaqueous environments, an estimate of these data can be made by interpolation of geologic parameters located in adjacent areas. For example, identification of lithology and structure located in rivers can sometimes be facilitated by surface outcrops occurring on bordering land surfaces.

#### Soil maps

88. These maps are prepared for a variety of purposes, e.g., agricultural, land use, and engineering. Soil surveys have been conducted over most of the United States. The distribution of soils is portrayed on maps and descriptions are normally in textural terms. Depths to parent rock may be included, if shallow. Scales vary widely, e.g., 1:25,000 or larger maps are available in agricultural areas, while 1:1,000,000 maps may represent the best coverage for other areas. Like geologic maps, the use of soils maps in conjunction with acoustic surveying is limited in scope, e.g., soils bordering the river channel may not be the same as those composing the bed of the channel.

#### Hydrographic maps and charts

89. These sources probably are used more frequently for acoustic surveying than all other types of maps available. Hydrographic charts depict hydrologic conditions and navigational information along most



navigable waterways within the United States. In addition, charts are available for large inland lakes and coastal areas of the U. S. Depth soundings in feet are presented on most hydrographic charts for both offshore and inland waters. Navigation aids, i.e., lights, radar reflectors, channel buoys, etc., are also generally indicated on inland waterway navigation charts. These navigation aids can be of tremendous help to acoustic survey operations both for navigation purposes and for keeping track of the acoustic profile location in the absence of precise positioning capability. The U. S. Army Corps of Engineers generally maintains detailed hydrographic charts of navigable waterways in their area of responsibility. The U. S. National Ocean Survey also prepares and publishes various types of hydrographic survey charts that are available for water bodies located primarily in coastal areas of the U. S. Chart scales vary considerably, ranging from 1:5,000 to 1:1,000,000 or smaller. Since natural and artificial changes are occurring constantly in most waterways, it is important that the latest published charts are available to the survey operation.

#### Special purpose maps

90. Special purpose maps are those that essentially are of limited coverage and depict data of specialized interest. An example is the engineering geology maps prepared by the CE for the Lower Mississippi Valley. These maps, generally of 1:62,500 scale, depict the environments of deposition and the associated sediments of each environment. The maps also delineate the surfaces of buried erosional surfaces and identify by age and lithology other relict surfaces existing above or below the surface of recent depositional environments located in the Mississippi alluvial valley. The engineering geology maps also contain selected cross-sectional profiles which depict subsurface lithology and geology. These profiles often intersect major river systems in the valley and may provide a significant amount of information to complement acoustic profile data obtained in the same area. Other special purpose maps are often published as the result of special investigations, surveys, or construction activities. Bathymetric, sediment distribution, and subsurface parameter maps have been made in support of pipeline



route surveys, ecological-environmental research programs, mineral resource surveys, etc.

#### Aerial photography and remote imagery

91. Remote sensing products such as aerial photographs and other forms of remotely acquired imagery represent important sources of data that can be of particular significance to presurvey planning activities. In the absence of other data sources, aerial coverage of the study area could provide varying amounts of topographical, geological, cultural, environmental, and hydrographical data required to adequately plan and conduct acoustic profiling surveys. In addition, air photography often represents the most recent documentation of the survey area, since these data are normally obtained prior to mapping. Aerial photo coverage often represents a valuable record of land use and physical changes that have occurred over a period of time. The changes occurring in stream regimen over a period of time can be of particular relevance to research studies concerned with streambank erosion. Air photo coverages are of many types and may vary in scale, format, and quality. In the United States, there are many sources of governmental, military, and privately held photography and imagery that could be used for presurvey planning.

#### Documents and records

92. Documents and records are valuable sources of various types of physiographic, geologic, hydrologic, and historical information. Some of the most common of these types of references include trade journals; geologic, geographic, soil, and hydrographic bulletins and periodicals; professional journals; private and governmental research and technical reports; and research publications issued by educational institutions. Reference materials may also be available from engineering firms, private societies, and individuals. Of particular interest is documentation of the results of research and project investigations in which the acoustic profiling technique was used. Literally thousands of miles of acoustic profiles have been obtained worldwide by private, commercial, and governmental organizations in a wide range of environments. In addition, the availability of soil boring data collected in



support of research and construction activities would be extremely helpful in determining bottom/subbottom characteristics of a proposed survey area, or for correlation of acquired acoustic data. Records of soil borings are normally carefully maintained by the organization responsible for acquisition of the soil samples.

93. Although background data are important for use as supplemental or planning information during presurvey and postsurvey efforts, it can also provide essential guidance in the field during the actual survey operation. Therefore, ample time should be programmed prior to the initiation of the survey to allow an adequate search, collection, and review of the various forms of data described in the preceding paragraphs. Personal communication with individuals familiar with the proposed survey area can also be of enormous value in providing details not contained in published documents, or in the absence of published material. Probably the most important contribution that the collection of comprehensive background data and its evaluation can provide is a determination of whether the physical, environmental, cultural, and other parameters of the survey area are reasonably conducive to the successful use of acoustic profiling systems and techniques. A comprehensive or even a cursory examination of the available data might indicate that other types of investigational methods are required for the successful completion of project objectives.

### Presurvey Planning

#### Survey lines

94. After the objectives of the proposed acoustic profiling survey have been assessed, and the review of the background data indicates the feasibility of the survey, the layout of the survey lines should be initiated. The survey lines should be placed on a map that provides adequate scale and coverage for the area to be surveyed commensurate with the amount of detail and accuracy required. The following paragraphs discuss some of the procedures which should be considered during the selection and plotting of survey lines.



95. The number of survey lines required will be normally dependent upon the objectives of the survey, and the size and configuration of the survey area. Time that has been allotted for the survey, the speed at which the profiling can be accomplished, and positioning requirements are also important factors influencing the total number of profile lines required. Efforts should be made to keep the number of lines to a minimum consistent with survey and project objectives. Acoustic surveys conducted in fluvial environments are essentially restricted in number of lines and line spacing by the constraints imposed by the physical dimensions of the channel. Surveys of a reconnaissance nature may require only a continuous profile line along the thalweg of the channel.

96. Most acoustic surveys use a grid pattern (Figure 34) with lines spaced at variable distances, depending on the requirement of the survey. Simplicity of navigation and maneuverability of the survey vessel should be kept in mind when laying out the survey line format. Grid pattern survey formats allow better control of bottom/subbottom data since both axes of the channel are covered. Two additional line patterns, shown in Figure 35, can be utilized for acoustic surveys, and the type used will depend upon the objective of the survey, survey area configuration, size of survey boat, systems employed, etc. Frequently, the plotting and configuration of the survey lines are affected by the presence of natural and man-made features which are situated within the survey area. Every attempt should be made to ensure that the positions of profile lines do not coincide with the positions of submerged hazards that may impose restrictions or danger to the survey boat and other equipment. The positions of transitory navigational hazards such as sandbars, debris, fish nets, etc. are not normally depicted on river navigation charts. Navigational hazards of a semipermanent or permanent nature are normally positioned on river navigation charts. When possible, profile lines should be configured so that the survey boat can work in an upstream direction, which allows better control over the track of the boat and better towing characteristics of profiling components.

97. The base map of the survey area on which survey lines and other pertinent information are plotted should reflect the detail and







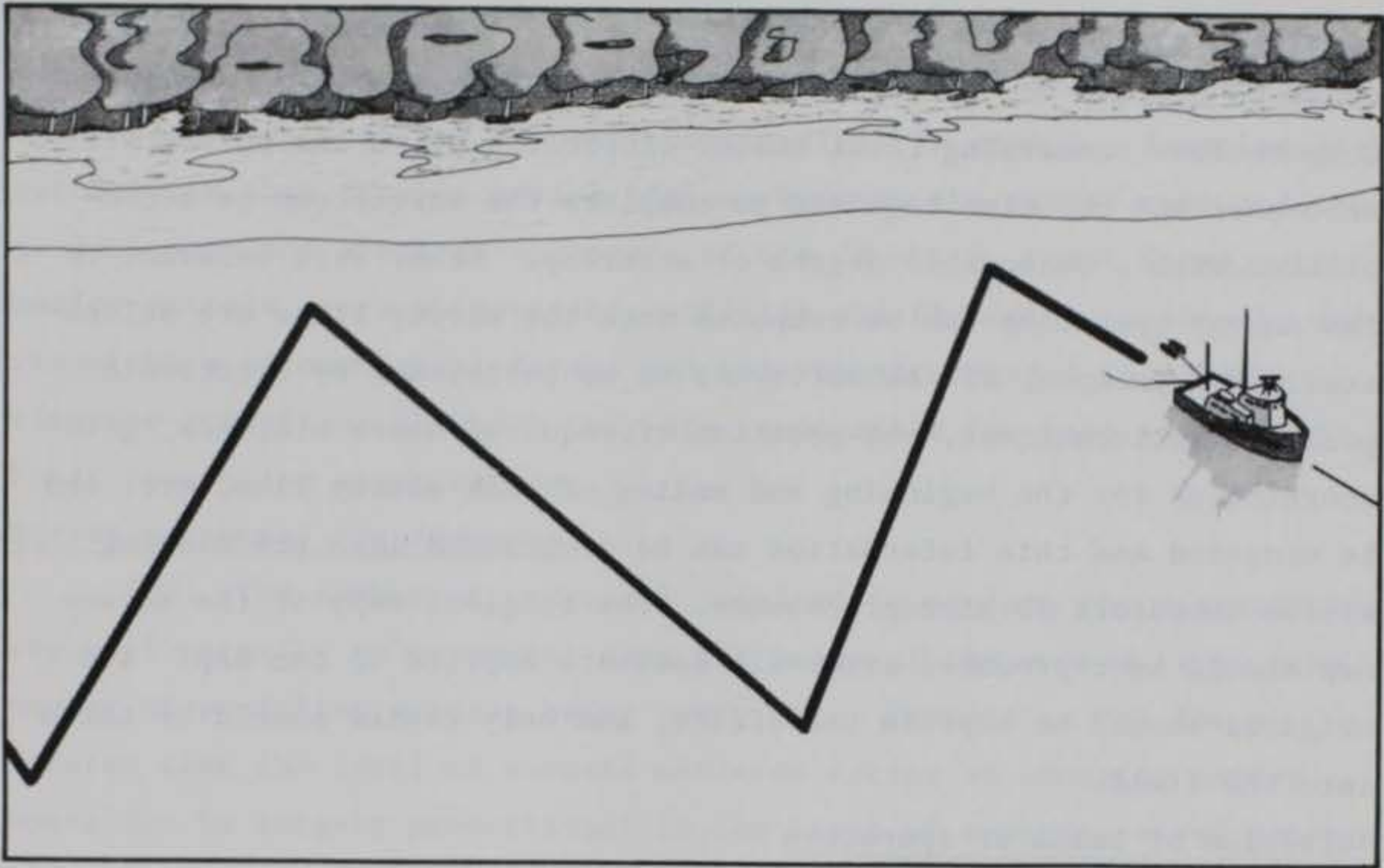

a. Rapid reconnaissance survey configuration

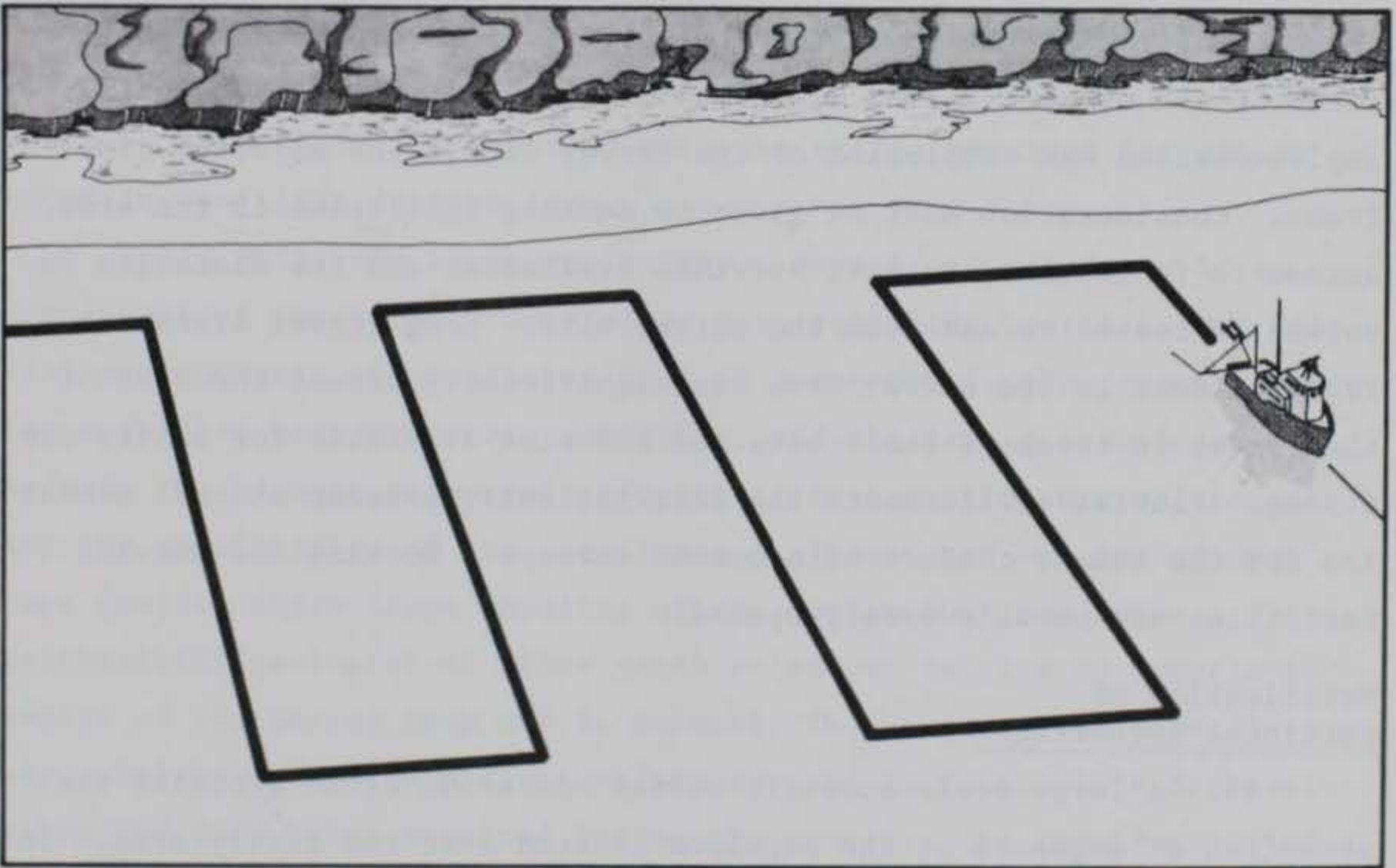

b. More detailed survey configuration

Figure 35. Two acoustic profiling line configurations designed to fit the operational objectives, time limitations, etc. of an acoustic profiling survey



accuracy required for the survey. The survey lines should be neatly drawn on the map and identified in numerical sequence where possible. Computations concerning total number of profile miles the survey will encompass and the time required to complete the survey can be accomplished with a reasonable degree of accuracy. Other data relevant to the survey operation can be computed once the survey lines are delineated. For example, if the survey is to be positioned by electronic positioning techniques, the position of required shore stations, grid coordinates for the beginning and ending of each survey line, etc. can be computed and this information can be programmed into positioning system computers or microprocessors. The original copy of the survey map should be reproduced after all data are applied to the map. The original should be kept in the office, and only copies should be taken into the field.

#### Selection of bases of operation

98. After the location, size, and extent of the survey area has been determined, attention should be directed toward the establishment of suitable locations from which the survey can be conducted. This facet of the overall survey operation is important to the successful implementation and completion of the survey within the allotted time-frame. Consideration must be given to docking facilities in the area, access to facilities, support services available, and the distances involved in travel to and from the survey site. Long travel distances from the dock to the survey area can significantly affect the cost of the survey in terms of fuel costs and the time available for onsite profiling. Fluvial environments characteristically present unusual scenarios for the timely conduct of acoustic surveys. Docking and service facilities are usually widely spaced.

#### Notification of pertinent authorities

99. A large-scale acoustic survey operation often attracts the attention of segments of the populace located near the survey area. In addition, the survey may be planned for waterways where a significant amount of commercial and pleasure boat traffic is common. This is



particularly true along the major navigable waterways. It is recommended that the proper authorities be notified in advance of surveys in waterways where moderate to heavy boat traffic is common. Examples of authorities that provide useful liaison between the survey crew and the general populace are area engineers of the CE, U. S. Coast Guard, state marine patrols, port authorities, wildlife and fisheries personnel, and dispatchers of commercial firms, and governments engaged in various riverine activities in which they are responsible for boat traffic of their respective organizations.

#### Survey personnel requirements

100. The number of personnel required to perform the acoustic survey will normally be dependent upon the scope of the survey, i.e., the number of profiling systems being used, etc. Experience has demonstrated that the level of success achieved during an acoustic survey operation is largely proportional to the level of experience and expertise of the survey crew. A combination of experienced boat operators, geophysicists, geologists, and electronic and engineering technicians is ideally suited for acoustic profiling surveys. The personnel categories listed above will generally have educational and experience backgrounds that are more closely associated with the skills required for use in acoustic profiling applications.

101. Only very large-scale survey operations require a large complement of personnel. Generally, most profiling operations in fluvial environments are conducted by 3 to 5 personnel. The requirement for a skilled boat operator, navigator, and electronic technician are perhaps the highest personnel priorities for acoustic surveys, considering the complexities of the electronic equipment and the impact upon data quality which inept handling of the survey boat can cause. The geophysicist/geologist or other earth scientist is also an important member of the survey team and is normally in charge of the overall survey. He/she knows the project objectives and is responsible for evaluating the data being acquired during the survey. The requirements of a prolonged, multisystem survey are demanding of personnel and equipment. An awareness at all times of the operational performance of the system



hardware and changes in data quality must be maintained if consistency of data quality is to be maintained. Changes in data characteristics may indicate a system component malfunction, a change in the operational configuration of the towed source/receiver, or it may indicate a significant change in the physical characteristics of the bottom/subbottom environment. Probably the greatest asset to well-planned and executed acoustic profiling projects is experience gained in the field.

### Implementation of the Survey

#### Installation of survey equipment

102. The proper installation of acoustic profiling system components and related supporting equipment aboard the survey boat is very important if efficient system operation and standards of safety are to be maintained throughout the survey. Where multiple system arrays are used, the systems must be carefully interfaced with one another and with ancillary equipment such as positioning components. Safety aspects of the survey operation must be considered at all times. Numerous high voltage cables and components are normally included in the system arrays on the survey boat within the cabin and on the deck. All electronic components must be properly grounded to avoid problems involving interference between various system components, and to reduce the risk of electrical shock to personnel. All potentially hazardous components, or areas in which these components are located, should be properly marked or roped off. Care should be taken to ensure the protection of critical electronic components from exposure to elements that are characteristically prevalent during waterborne surveys, i.e., rain, water spray, excessive heat, ice, direct sunlight, etc. All equipment should be secured, when possible, to the deck, or workbench, cabinets, etc. inside the cabin to prevent possible damage to the equipment during periods of rough water conditions or sudden maneuvers made by the survey boat. Items of equipment such as power generators, sound source components, cables, hydrophones, etc. normally must be left on the deck. These items are generally not susceptible to weather elements, except for



generators which must be covered when not in use.

103. When survey equipment must be placed on rented, leased, or borrowed survey boats, some problems may be experienced in installing the equipment because of lack of space or other considerations. Because a large variety of boats exist, the user is faced with different boat geometries that may have various effect on the performance of certain system components. Each boat seems to have its own array of operating parameters that affect the location, configuration, and consequently the operational characteristics of acoustic profiling system components. For this reason and other reasons, it is strongly recommended that long-term users seriously consider the purchase or long-term lease of a vessel on which all survey systems and equipment can be permanently installed.

#### Initial systems check

104. Before the actual acoustic profiling survey is initiated, all survey and support systems should be checked and calibrated for proper operating performance. This checkout is particularly important when operating in operational environments where the systems must be adjusted to each type of environment. Depending on the number and type of survey systems involved in the survey, 1 to 3 days should be allocated for system checkout and required adjustments. During the initial systems check, many decisions regarding system operational parameters, i.e., towing configurations, frequency spectrums, power output levels, filter settings, record scales, etc. are reached. Trial runs in the survey area are best accomplished in the deepest water available. This approach is recommended because increased noise levels and closely spaced multiple reflections are not as troublesome in deeper water depths, i.e., depths of 50 ft or greater. In addition, it is suggested that systems checkout be performed where bottom/subbottom conditions will permit a reasonable depth of penetration. This approach facilitates the adjustments that must be made to select optimum operating settings for the various system components. Subsequent changes in profile data or system performance can be more readily evaluated if the systems are calibrated while obtaining good data. All profiling systems



should be deployed collectively during the systems checkout period. If electronic positioning systems are being utilized, the systems test phase of the survey is an ideal time to evaluate the positioning equipment and to ensure that positioning and acoustic survey systems are interfaced correctly.

105. If as a result of the systems checkout there is an obvious need for system repair or adjustment, steps should be taken to correct the situation. Further checks at locations within the survey area are advisable after repairs have been made. If after the final system checks are made all systems appear to be operating satisfactorily, the actual survey can be initiated. One additional advantage of the systems checkout period is the opportunity afforded the survey crew to become familiar (unless they are a seasoned crew) with their assigned duties. This "grace period" can be utilized to develop the coordination and teamwork that will be required throughout the survey.

#### Deployment and Operation of Acoustic Profiling Systems

106. A discussion and description of procedures and techniques used with acoustic profiling systems are contained in the paragraphs below. Recognizing the wide range of systems, components, and environmental parameters that a potential user may encounter, no attempt is made to describe in detail individual component adjustments and settings that should be made during a survey. System and component performance characteristics along with "how to" instructions are generally contained in operational manuals supplied with survey systems and components. However, basic procedures and techniques acquired from experience in the field are presented. They should be of some help to potential users of acoustic survey systems. This discussion is primarily limited to those systems that have been utilized by the WES during the course of acoustic profiling surveys conducted over the past decade. Because the proper utilization of sound source and receiving components is particularly critical for optimum acquisition of high quality bottom/subbottom data, the major emphasis is directed toward these components.



### Towing configurations

107. The most important factor affecting the operational characteristics of the CSRP system is probably the configuration and manner in which the sound source and hydrophone array is towed. The following paragraphs discuss some of the more relevant criteria concerning the proper deployment of pinger and boomer-type components.

108. Pinger systems. Three variations of pinger source/receiver components are available and utilized in acoustic profiling. These variations are: (a) the towed "fish," (b) the "over-the-side," and (c) the "hull-mounted" configurations (Figure 36). The towed pinger transducer arrays should generally be used in deeper, offshore waters

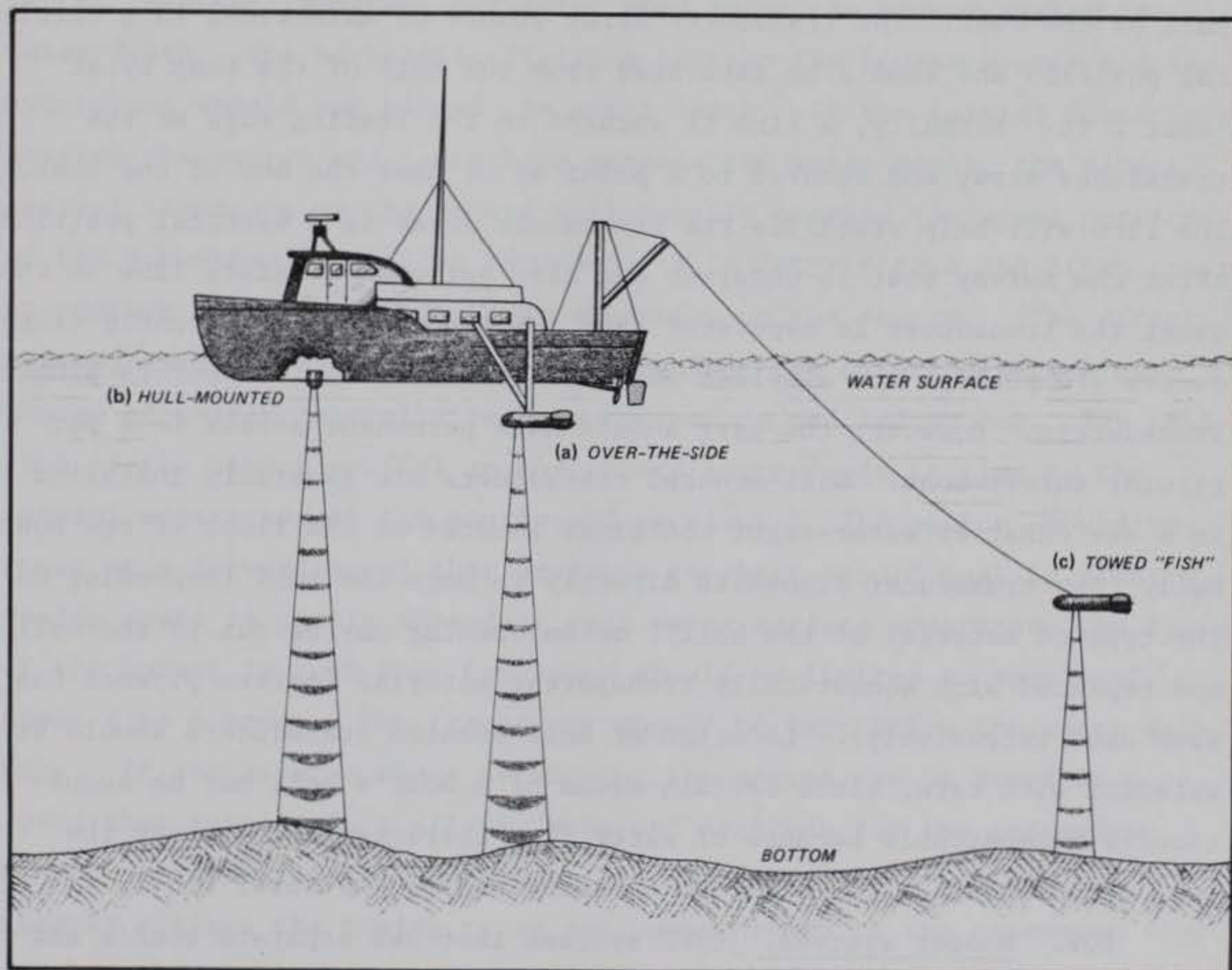

Figure 36. Three variations of towing configurations used with pinger-type acoustic profiling systems that are widely used in aqueous environments in support of a wide range of acoustic survey applications



and should be towed from booms, davits, or other hoisting equipment most commonly situated on or near the stern of the survey boat. Towed transducer vehicles (towfish) tend to be quite heavy and are difficult to manage without the use of hoisting equipment, but can be used in fluvial environments, if desired. However, because of the variability in channel water depths their use is generally not recommended. If towfish are used, tow depths should be kept to the minimum depth required for acquisition of reasonably good data. Over-the-side pinger transducer arrays can be attached to the side of the survey boat in a number of ways, one of which is illustrated in Figure 36. These arrays should be positioned deep enough in the water so that the transducers are below the keel of the survey boat to minimize reflection of transmitted energy from the hull of the boat. The transducer array should be maintained in a vertical position and should be separated from the hull of the boat by at least 2 ft. Normally, a line is secured to the leading edge of the transducer array and secured to a point at or near the bow of the boat. The line will help stabilize the transducer array in a vertical position after the survey boat is underway and also serve as a safety line in the event the transducer is separated from its mounting. Hull-mounted transducers are perhaps the simplest and most efficient way to operate pinger transducers. However, the user should have permanent access to a particular survey boat. Hull-mounted transducers are generally installed in a sea chest or water-tight container located on the floor of the boat hull. The transducer transmits directly through the hull (depending on the type of material of the hull), or an opening may be cut in the hull and replaced with acoustically transparent material (marine plywood has been used extensively). Location of hull-mounted transducers should be selected with care, since certain areas of a boat's hull may be acoustically impenetrable because of water flow characteristics along the hull of the boat, e.g., air bubbles entrained in the water flow.

109. Boomer systems. CSRP systems that use separate source and receiver components and are towed at various positions and distances in relation to the survey boat normally require considerably more expertise in handling. The boomer sound source and hydrophone towing



configurations differ somewhat from other types of towed systems that use separate source and receiver, i.e., sparkers, air guns, etc., in that the boomer's source and receiver components are towed at or very near the water surface. Various towing configurations, in relation to the survey boat and the spacing of the source and receiver, may be used with the boomer system. Figure 37 illustrates three basic variations that have been used with boomer systems. The most commonly used configuration is probably the one in which the source and receiver are towed behind the survey boat and separated by the boat's wake. This mode can be utilized by small survey boats (30 to 65 ft in length). It is important to keep the source and hydrophone out of the survey boat's wake because of the energy attenuation characteristics of wake turbulence. Another important parameter when using the boomer system is water depth. The horizontal distance between the boomer source and the hydrophone should not exceed the water depth. If the lateral distance between the source and hydrophone exceeds the water depth, the direct arrival signature on the record will usually overlap the upper portion of the subbottom data being recorded. This interference can often cover or confuse valid reflection data appearing on the record. (The direct arrival is a record signature resulting from the direct, initial exchange of energy laterally between the source and hydrophone. The position of the direct arrival on the record corresponds in time to the lateral separation of the source and receiver.) The source should be towed at a forward speed that produces the best record quality. While towing speed is partly dependent upon water surface roughness, the design of the boomer is such that tow speed should be limited to speeds of about 4 to 6 knots. The transducer should be kept below the water surface. If the water surface is smooth, the source can be towed at a speed that results in a slight "nose-up" attitude for the catamaran float. This towing attitude is not binding, however. The WES frequently affixes the towing ropes and power cables to the catamaran float so that the whole unit is towed just below the surface of the water. The tow position of the hydrophone is probably more critical to the acquisition of quality data than that of the source. It is extremely



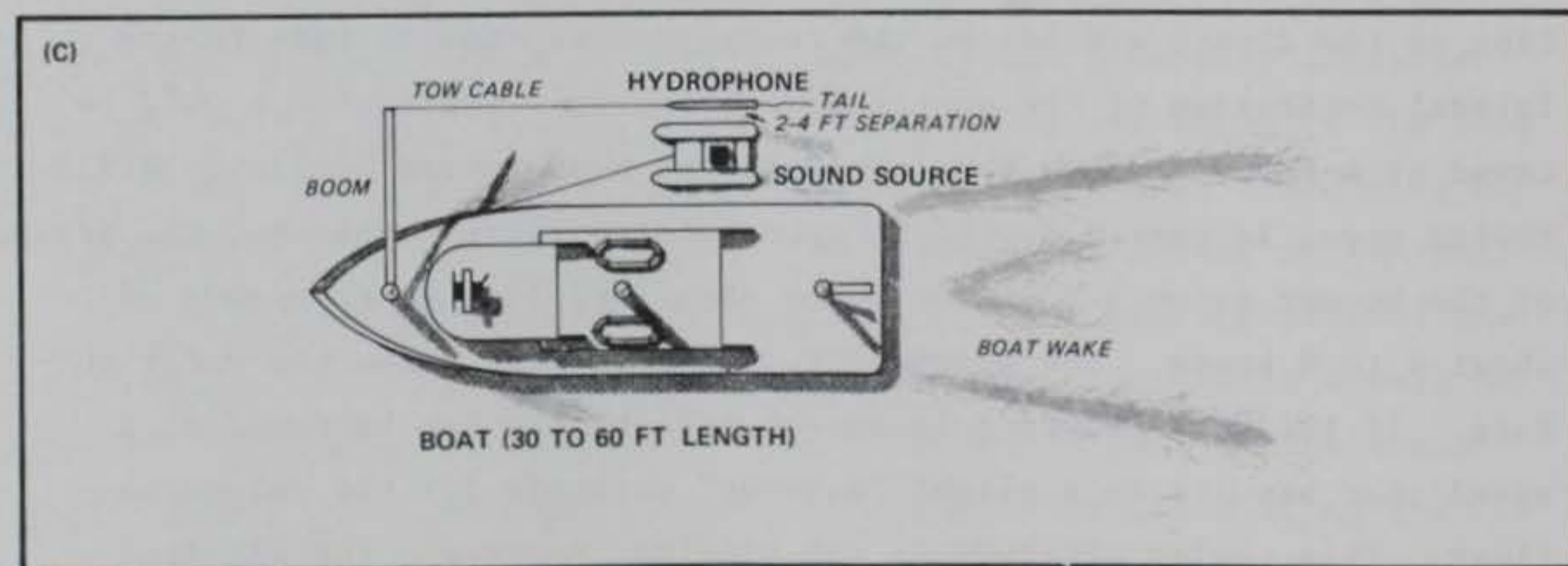
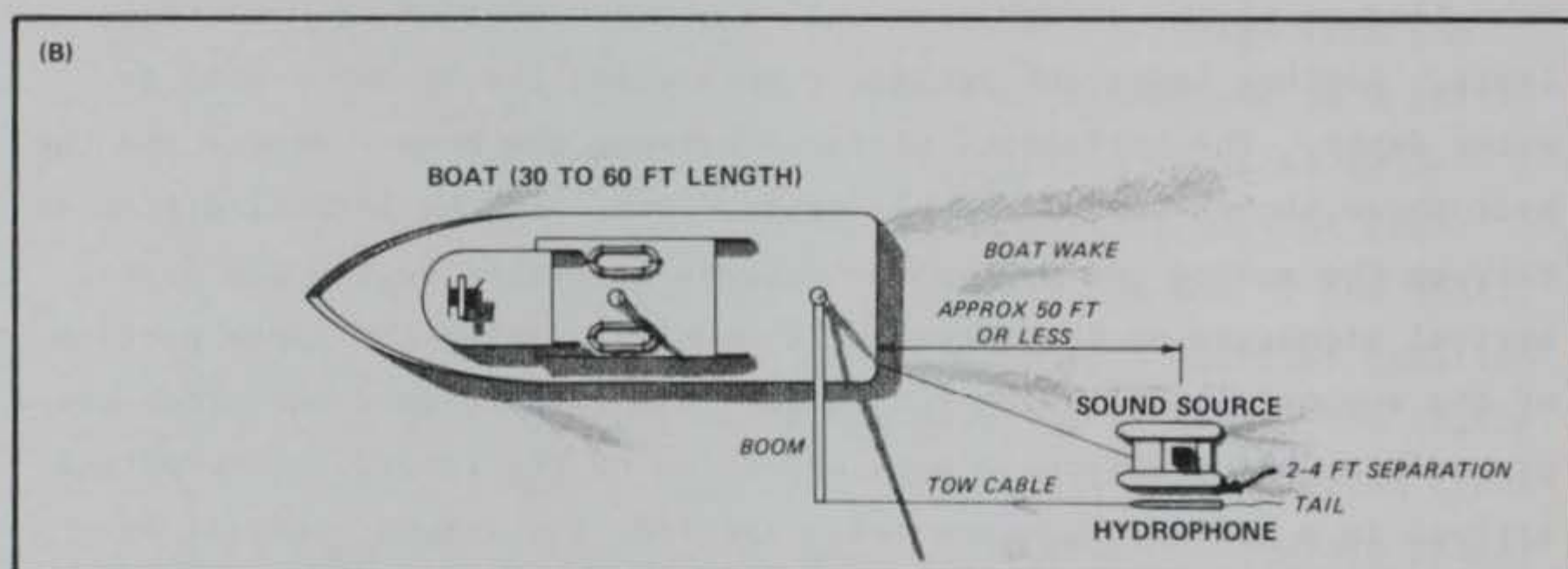
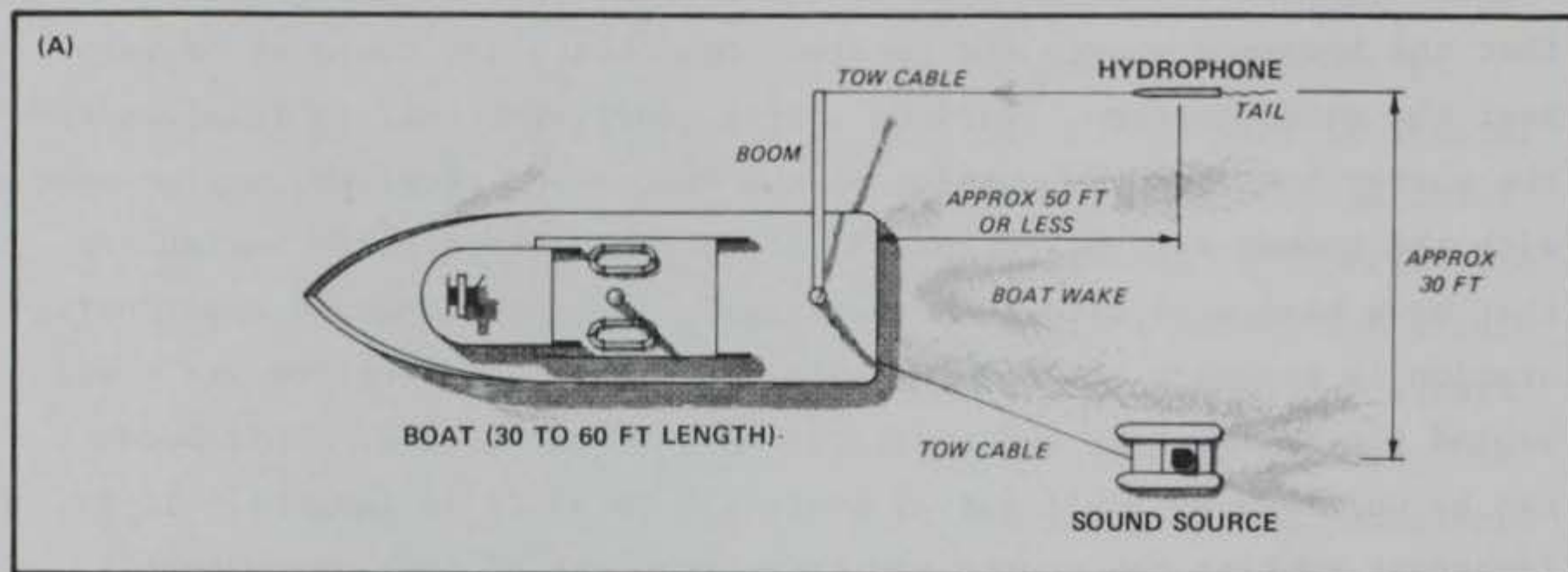

Figure 37. Three basic towing configurations widely used with boomer-type acoustic profiling systems (Towing configurations may change somewhat depending on size and type of survey boat used.)



important that the tow depth of the hydrophone active section be maintained as close to the surface of the water as possible (without breaking the surface of the water at frequent intervals). If the hydrophone array is towed too deeply, the reflected signals from the bottom and subbottom will be received by the hydrophone, travel to the water-air interface, and be reflected back to be received by the hydrophone, resulting in the recording of a double pulse line instead of a sharply defined single line reflection. The hydrophone should ideally be towed from a boom that allows the proper tow depth to be maintained at various towing speeds. Buoyant, flexible tubing, such as the type used for pipe insulation, can be placed around the tow cable of the hydrophone to prevent the weight of the tow cable from sinking the hydrophone. The amount of floatant and its position relative to the active section of the hydrophone can be determined by experimentation in the field. The leading and trailing edges of the flotation should be streamlined with tape to prevent the generation of small, turbulent wakes. The hydrophone array generally should be positioned so that the midpoint of the active section is directly opposite the midpoint of the source. The hydrophone tow cable should be secured to the boom, or other fixture of the boat, with elastic shock cord. Shock cord absorbs much of the vibration originating from the survey boat that would be transmitted along the tow cable to the hydrophone. It is often useful to tie a flotation device to the end of the tail of the hydrophone. The use of this device tends to keep the hydrophone tracking in a true manner because of the increase in drag.

#### Towing speeds

110. Towing speeds are generally governed by the type of sound source and receiving components used, physical and environmental characteristics of the survey area, and environmental conditions encountered while the survey is underway. The design and method of towing sound sources and hydrophone arrays generally dictate the speed at which acceptable levels of data can be acquired. Over-the-side and surface-towed source/receiver arrays are probably most susceptible to limitations imposed on tow speed. These arrays generally are limited to a



maximum tow speed of about 6 knots. If this limit is exceeded, the quality of the acoustic data may deteriorate rapidly because of pitching of the towed sources and turbulent water flow around the source and receiving arrays. The system arrays designed for deep, underwater towing are usually characterized by hydrodynamically designed vehicles housing the source and hydrophone. The tow speed range for arrays of this type is usually 5 to 15 knots. Hull-mounted transducers, e.g., primarily pinger types, may operate satisfactorily at speeds up to 20 knots or more. Additional factors affecting the speed at which acoustic source/hydrophone arrays may be towed are firing rates of the source, horizontal scale of the record desired, survey boat design, etc.

111. The survey boat should maintain a constant profiling speed throughout the period of the acoustic survey, in view of the effect boat speed has on record horizontal scale and quality. Fluctuations in tow speed will also result in variations in the height of underwater towfish in relation to the bottom. This may create distortions in the vertical scales of the acoustic records.

#### Acoustic data display and recording

112. The principal real-time display of CSRP data is the graphic record. Since the interpretation of these data depends heavily on the quality of the acoustic record, the recorder(s) should be monitored diligently by survey personnel. For normal shipboard installation, the recorder should be secured to a flat surface at a height convenient for the operator. Power to recording and display components should be supplied from a power source other than the source furnishing power for the sound source. A line voltage meter should be utilized to closely monitor the line voltage since the recorder operation is very susceptible to voltage surges. After paper is installed in the recorder and paper speed and advance control are checked for proper operation, gain control levels should be adjusted for proper writing contrast. This procedure can be done by actuating event marker controls and observing the relative darkness and intensity of the event marks as they appear on the record. Most recorders usually generate scale lines when the write circuits are activated. Check these lines for writing intensity and



styli performance. Selection of sweep speeds and record scales will normally depend on personnel preference, objectives of the survey, and water depths in the survey area. High sweep speeds normally expand the vertical dimensions of the record so that more detail in the subsurface column can be observed. Slower sweep speeds compress the water and sediment column. However, the slower sweep speeds allow the user to record data in deep waters and where deep penetration is being achieved, i.e., on the order of hundreds, even thousands of feet. Thus, for high resolution, shallow penetration data, the higher sweep speeds are desirable. After initial recorder adjustments are made, the key pulse or triggering functions of the recorder should be tested to ensure that the recorder is supplying trigger pulses to the sound source. The input signal from the receiving components can be monitored at the same time. A bottom return should be displayed on the record at this time, along with subbottom data if penetration is being achieved. Further adjustments of gain levels and filter controls may be necessary at this time. When the record has been adjusted to the best level of presentation possible, no further adjustments should be made unless an abrupt change in data quality occurs.

113. Overall noise level must also be considered in relation to the recording gain, or the contrast, of the record. This is best checked by securing the sound source and then recording received noise. It is important to keep recording gain levels just below that level at which background noise becomes intolerable. Some background noise usually must be tolerated because of weak data signals that would be lost if background noise signatures were eliminated completely from the record.

114. It is recommended that a slave recorder or a magnetic tape recorder be used when possible. If the only record of the data is a single graphic record, there is no degree of freedom to examine the data being received in ways other than that chosen at the time of recording. The slave recorder can be used to experiment with various recording functions without interrupting the continuity of the master graphic recorder record. In this operation the user searches for the best methods on the slave recorder with which to improve the master record.



Furthermore, the slave recorder can serve as a standby system so that the continuity of the data can be maintained if malfunctions suddenly occur in the master recorder.

115. During the operation of the graphic recorder, the acoustic record should be annotated by the operator with any information that could be of value during the subsequent office analysis of the data. Detailed record annotation in the field helps preclude the possibility of hazy recall on the part of the survey personnel if a considerable lapse in time should occur between survey completion and data interpretation. Items that represent information that should be documented on the acoustic profile record during the survey include: (a) name of survey area, date, and line number; (b) position fixes; (c) time documentation; (d) system operating criteria; and (e) spurious signals. These are discussed below.

116. Name of survey area, date, and line number. Records representing a day's work should be separated from previous or subsequent days of profiling. Each record should be dated accordingly. Profiles should be identified in such a manner that lines can be grouped in logical arrangement, e.g., strike lines can be labeled A, B, C, etc.; dip lines 1, 2, 3, etc.; and interconnecting lines between adjoining dip lines 1-A, 2-A, etc. Many alternate arrangements can be fabricated by the user at his discretion in the proper identification and orderly assimilation of large volumes of profile data. The important point is that the records should be properly identified and maintained throughout the period of the survey.

117. Position fixes. Position fixes should be numbered consecutively from the initial fix to the last fix of the survey. Repetition of numbers should be avoided, even though the records will be separated by the number of days of operation. A new day's operation should use the next number following the last position fix of the previous day.

118. Time documentation. Time of the day during the survey operation should be annotated frequently on the acoustic record. This can be accomplished in several ways. The time can be noted when event marks denoting position fixes are marked on the record, or an event mark can



be made for a time mark. Some of the more sophisticated positioning systems provide an interfacing arrangement with the graphic recorder so that the position fix and time of fix is automatically recorded at pre-selected intervals. Some graphic recorders incorporate controls whereby the scale lines can be presented with periodic precision time interruptions. The time break sequence is usually derived from an internal crystal oscillator that begins precisely when a control switch is activated at the operator's discretion. Documentation of time during acoustic surveys can be particularly helpful for preparation of postsurvey bathymetric maps, or depth to subbottom horizons computation, in areas affected by tidal fluctuations during a 24-hour period.

119. System operating criteria. Documentation of component configurations used in a survey can be very helpful during and after the survey. Items which should be documented during the survey include system frequency, power output, depths of transducer and hydrophone arrays, gain settings, filter settings, recorder paper speed, and recorder scales. Survey personnel may be required to adjust the operational mode of various system components to obtain optimum performance from the systems. Documentation of these changes is necessary for the success of the data interpretation phase of the survey and is useful for reference during subsequent acoustic surveys.

120. Spurious signals. Spurious signals appearing on the record should be identified if possible and related to a known source aboard the survey vessel, or within the survey area. Background noise, radio frequency interference (RFI), side echoes, multiple reflections, etc. are examples of spurious signals that should be noted on the record while the survey is in progress.

121. Miscellaneous. Other items that can be of value if annotated on the record include seastate conditions, survey vessel speed, direction of travel, engine rpm's, and prominent landmarks.

122. Wet-paper records should be carefully labeled and placed in protective envelopes or other suitable containers. Dry-paper records generally cannot be folded because of the way they are manufactured. They should be rolled or cut into separate sections and maintained flat.



Experience has shown that records can be easily stored and handled if individual profiles are separated and placed in separate containers. Because some recording paper types are light-sensitive (wet-paper records), the records should be placed in protective envelopes as soon as possible. The envelopes also prevent unnecessary wear and tear and prevent soiling. They also provide a convenient method for cataloging, filing, and retrieval of large volumes of acoustic records. Each container should be annotated with the name of the survey area, project, survey line number, and date the profile was obtained.

#### Power output of sound sources

123. In most instances, maximum penetration of the subbottom is achieved by the use of maximum power output levels. However, while a significant increase of transmitted power may result in an increase in the depth of subbottom penetration, the objectives of the survey should be carefully considered. If the survey objectives can be accomplished with less than maximum penetration, power output levels should be restricted to the minimum levels required. This is particularly important in very shallow-water operations where source output power must be held to a minimum if reverberation noise is to be restricted. It is recommended that transmitted power levels be held as low as possible at the inception of the survey and increased only gradually until the desired depth of penetration is obtained. When that point is reached, the power settings should not be changed unless a change in the depth of penetration occurs.

#### Frequency selection

124. Operating frequencies during the survey will depend largely on the type of source used, the depth of penetration desired, and the degree of resolution required. If maximum penetration of the subbottom is required, the lowest frequency or broadest frequency spectrum should be used. Some acoustic profiling systems offer only one or possibly two choices of frequency. However, many systems are designed for operation over a wide range of frequencies, and the user chooses the optimum frequency bandpass by selective filtering. The highest frequencies available should be used if desired penetration is achieved. The user should



strive to maintain a reasonable degree of balance between penetration and resolution. Experimentation with various frequency and power output configurations in the survey area will normally provide the user with the best combination for satisfying the survey requirements.



## PART IV: DATA COLLECTION AND ANALYSIS

125. As a part of the demonstration of the applications of waterborne geophysics in the fluvial environments, geophysical surveys were conducted on the White, Mississippi, Missouri, and Ohio Rivers. The purposes of these surveys were to demonstrate their operational and technical applicability in a variety of typical fluvial environments and to show that the type and quality of data collected could contribute meaningfully to hydraulic studies generally as well as to streambank erosion studies. This part of the report describes the geophysical systems used, how they were used, the environmental characteristics of the surveyed reaches, and the interpretation of the survey data.

### Description of Selected Geophysical Systems

#### In-house systems

126. CSRP systems. The EG&G Uniboom is a high resolution CSRP system which operates in the 400- to 14,000-Hz frequency spectrum. The basic system is comprised of the Model 230-1 sound source, the Model 234 Energy Source, and either the Model 262 (single-element) or Model 265 (8-element) towed hydrophone, or both. The WES system is complemented by a Model 4600 and Model 3200 graphic marine recorder manufactured by EPC Labs, Inc. A Model 3500 Khronhite variable bandpass filter, and various external amplifiers and magnetic tape recorders are also utilized with the Uniboom system. Figure 38 shows a typical system/component survey array used by WES during field operations in support of this study. Maximum power output capability of the WES Uniboom system is 300 Joules (J). Depth of penetration capability ranges from about 50 ft to more than 200 ft, although penetration in excess of 300 ft has been achieved by WES and other users of the system. The Uniboom source is mounted on a catamaran-type float and is normally towed on the surface of the water alongside or behind the survey boat. The separately towed hydrophone component is towed opposite the source, either close beside the catamaran float or on the opposite side of the



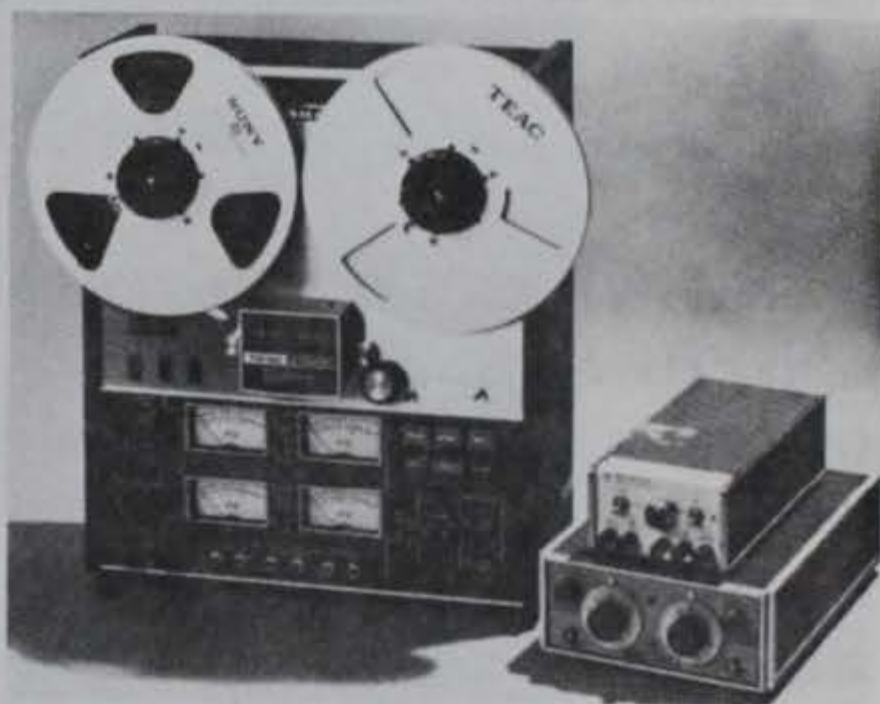
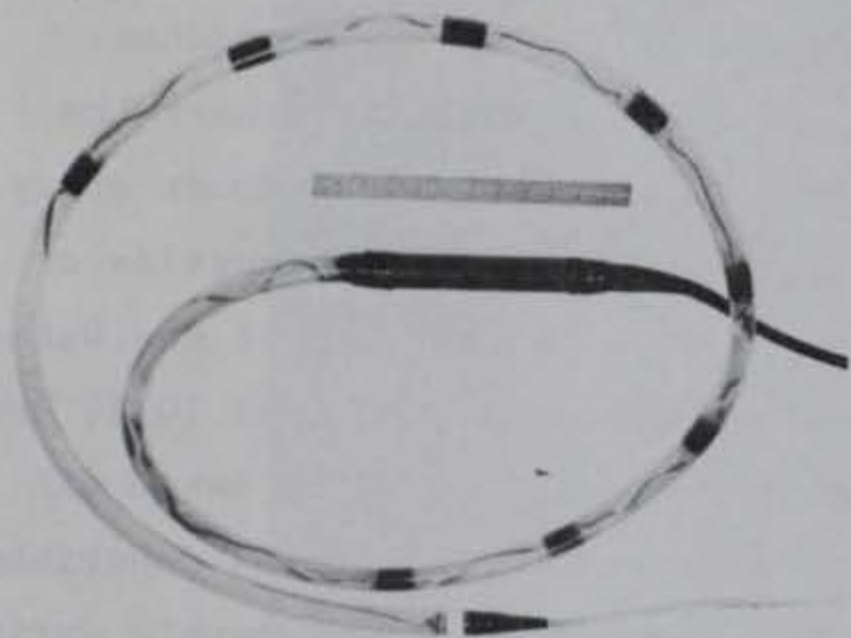
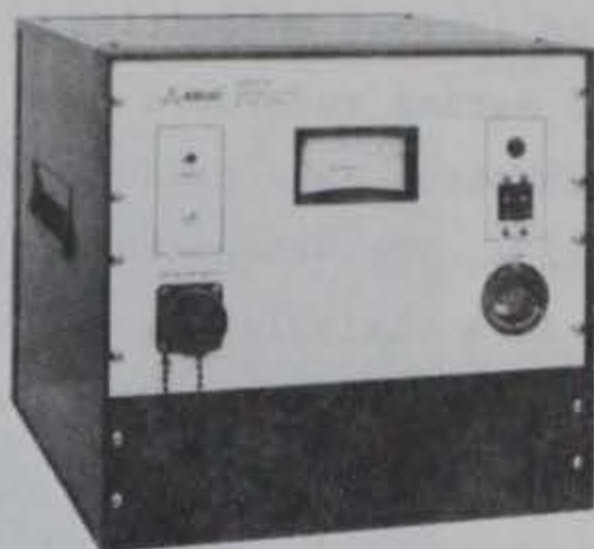
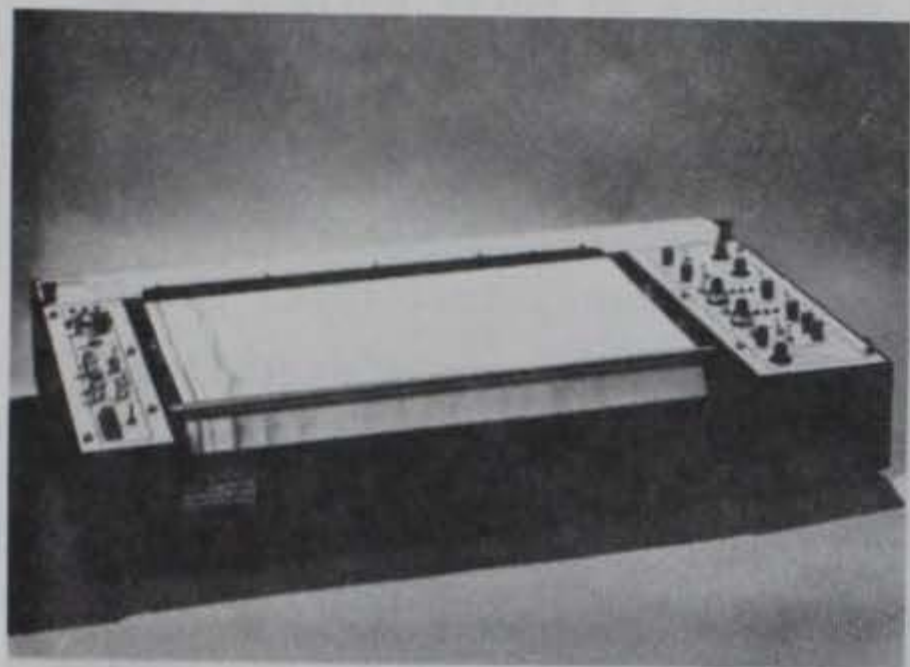

Figure 38. EG&G Uniboom CSRP System owned by WES



survey boat or its wake. Operational towing speeds range from about 4 knots up to approximately 6 knots, depending on water surface roughness and current velocities. The EPC Labs, Inc. Models 4600 and 3200 graphic marine recorders used by WES for real-time display of the Uni-boom subbottom data produce 19-in.-wide records of the dry-paper type.

127. The WES-owned Ocean Research Equipment, Inc. (ORE) pinger system is a variable-frequency, high-resolution subbottom profiling system operating in the frequency range of 3.0 to 7.0 kHz. Maximum power output capability is 10 kw. Maximum resolution capability of the system is on the order of 1 ft (thinnest sediment layer observable on the profile record). The system is capable of operation in two towing modes: (a) an over-the-side array (Figure 39) where the transducer array is attached to the survey boat and lowered and raised over the side of the boat, and (b) a "towed fish" in which the transducer array is contained within a streamlined vehicle which is towed alongside or behind the survey boat at various depths below the surface of the water (Figure 40). The over-the-side array is designated the Model 1032, and the towed fish configuration is called the Model 1036. The basic ORE system is composed of the two transducer array configurations described above, the Model 140 transceiver and the Model 4000 Giffit graphic marine recorder. The WES ORE system is complemented by the ORE Model 175 split trace programmer which allows the programming of dual channel data for side-scanning sonar or other acoustic profiling systems to be recorded simultaneously with data from the pinger system. The transducer arrays perform the dual function of source and receiver. Depth of penetration capability with the ORE pinger system normally ranges from about 30 to 75 ft in fine-grained, low- to medium-density sediments. Penetration is usually less in those environments characterized by coarse-grained sediments. Maximum penetration that has been obtained with the WES system is about 100 ft, with the average on the order of 30 ft over a wide range of environments. Display of acoustic reflection data is accomplished by the use of the Giffit graphic recorder. This recorder utilizes a 19-in.-wide wet-paper record format.

128. The WES owns a 12-kHz transducer manufactured by ORE. The



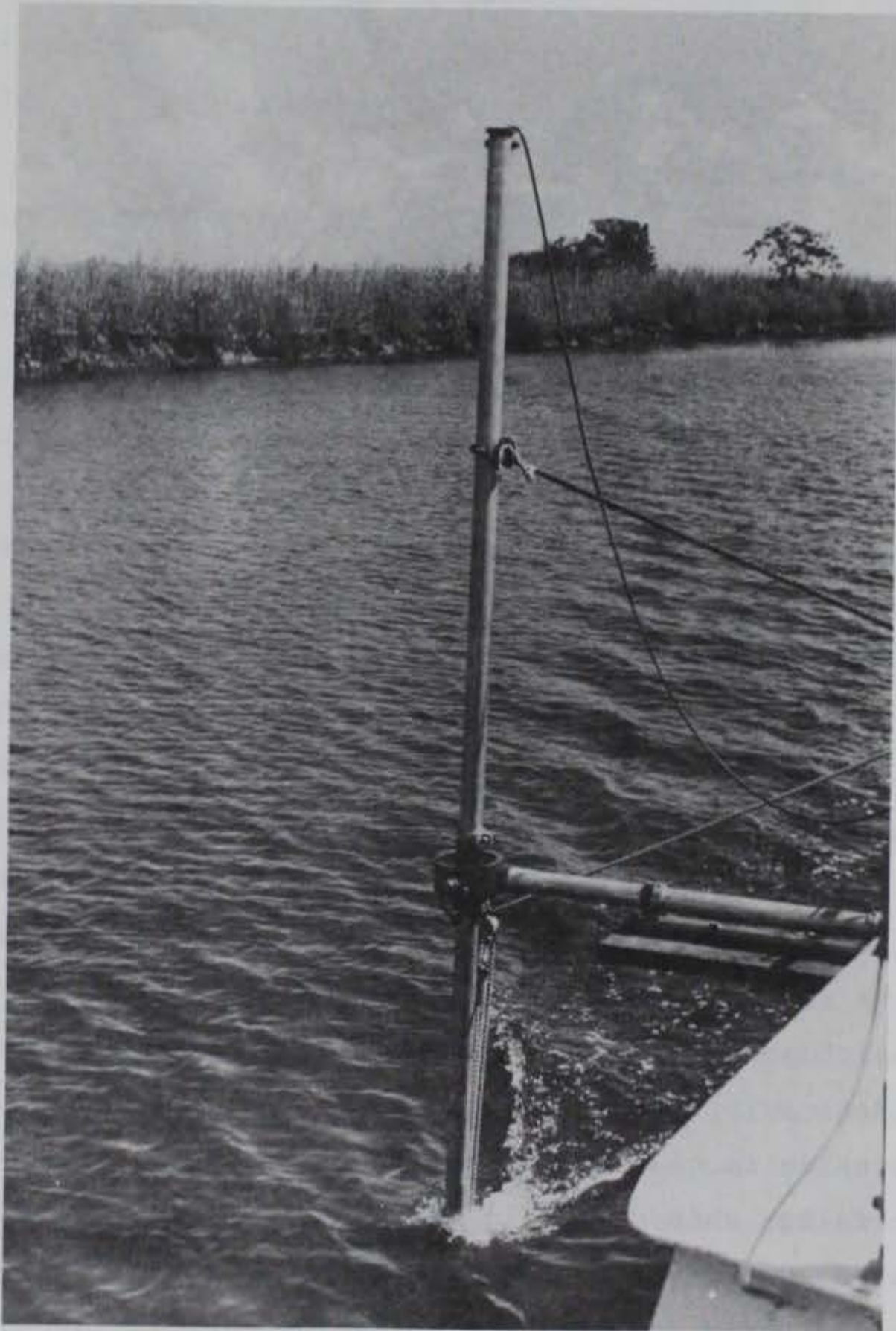

Figure 39. ORE Model 1032 "over-the-side" pinger array in towing configuration (Transducer is approximately 3 ft below water surface.)





Figure 40. Towfish component of the ORE Model 1036 pinger subbottom profiling system (The source shown here has been modified to include side-scanning sonar transducers; courtesy of Ocean Research Equipment, Inc.)

transducer is compatible with the system components utilized in the Models 1032 and 1036 pinger system and provides excellent resolution (6 in.) for bottom profiling and shallow subbottom penetration. Penetration depths of up to about 30 ft are often achieved with the 12-kHz transducer, although this depth is normally restricted to low-density sediments. Because of its relatively high frequency characteristics, little penetration should be expected in coarse-grained materials. The WES usually employs this system in the over-the-side towing arrangement. Maximum power output capability of the 12-kHz transducer is approximately 2 kw.

129. Side-scanning sonar systems. The WES owns an ORE Model 1098 side-scanning sonar system. The system consists of the Model 170A transceiver, the Model 175A split trace programmer, the Model 198 towed fish, and the Model 4000 Giffit graphic recorder. The system operates at a frequency of 97 kHz. Maximum range of the system is approximately 1000 ft in either the port or starboard direction. The horizontal



beamwidth of the emitted acoustic energy is 2 degrees. The vertical beamwidth is approximately 35 degrees. Swath widths along the track of the survey boat can be as wide as 1000 ft on either side of the towfish. However, optimum bottom coverage is more on the order of 500 ft in each direction if maximum resolution of the bottom is desired. This consideration is due to a number of variables, the principal ones being signal attenuation and absorption, water depth, and bottom topography. Weight of the towfish is approximately 80 lb.

#### Contract systems

130. The use of additional CSRP systems, i.e., sparker and air gun systems, by contract for these studies was considered; however, it was determined that the additional types of CSRP systems available for lease did not offer any significant advantages for application in fluvial environments over those at the WES.

131. The EG&G Model Mark 1B side-scanning sonar system was one of three side-scanning sonars used by WES during field survey operations in support of this investigation. The Model Mark 1B system is comprised of the Model 259-4 dual-channel recorder, a towed fish containing port and starboard transducers, and associated tow cables. The system is DC-powered, either by battery or with an AC-DC converter. The 259-4 recorder contains most of the electronic components which control most of the system functions. The recorder provides dual-channel printing of reflection analog data, and sweeps from the center of the record so that the bottom track is adjacent between the channels. The system can be operated in one of two modes: (a) the search mode which is designed for the location of man-made objects, i.e., sunken boats, pipelines, etc., and (b) the survey mode which emphasizes the overall features of that portion of the bottom scanned by the system. The Mark 1B system operates at a frequency of approximately 105 kHz. The horizontal beamwidth is 1.2 degrees. The vertical beamwidth is 20 degrees with the transducers tilted down 10 degrees, and 50 degrees with the transducers tilted down 20 degrees. Range of the system is approximately 1500 ft in either direction. Weight of the towfish is about 55 lb. The Mark 1B system is shown in Figure 41.



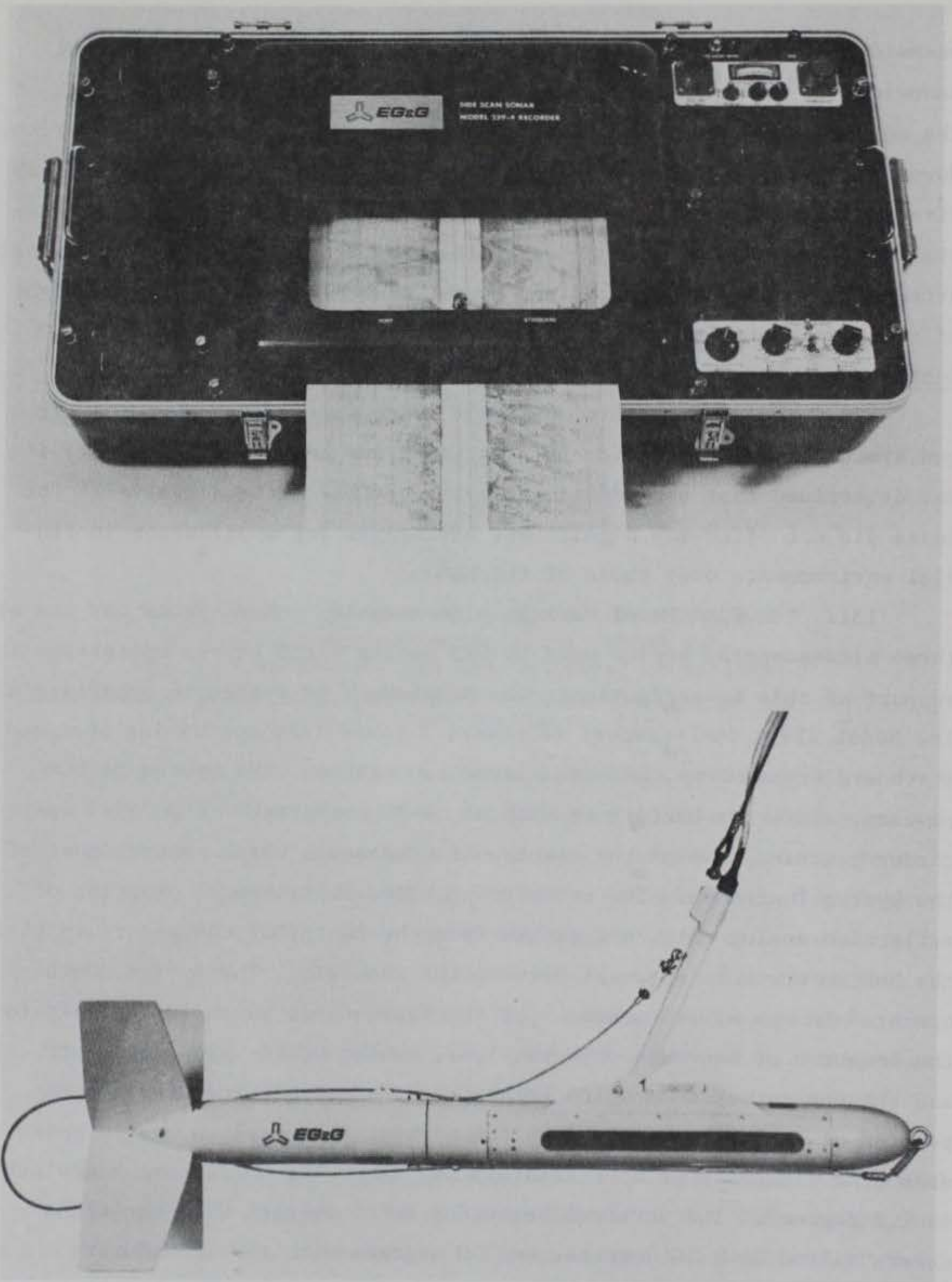
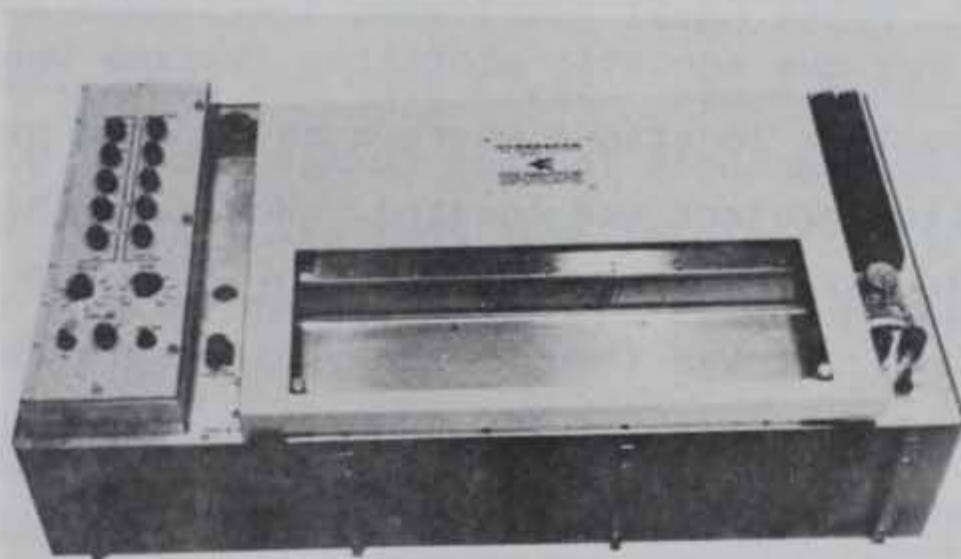

Figure 41. Basic components of the EG&G Mark 1B side-scanning sonar system (courtesy of Environmental Equipment Division, EG&G, Inc.)



132. The Klein Associates, Inc. Hydroscan System 520 consists of the Model 521 graphic recorder, the Model 422S towfish, and miscellaneous components, i.e., towing cable and power cable. The graphic recorder is a dual-channel, wet-paper type recorder that will also use dry paper for data printing. The recorder prints the record from the center out to the edge so the display is in correct perspective. Maximum range of the Hydroscan side-scanning sonar system is approximately 1600 ft per channel. The output frequency of the system is 100 kHz. The horizontal beamwidth is 1 degree. The vertical beamwidth is 40 degrees when the transducers are tilted down 10 degrees from the horizontal. Weight of the towfish is 48 lb in air. The recorder and towfish components of the Hydroscan system are shown in Figure 42.



DUAL CHANNEL  
SIDE SCAN SONAR RECORDER

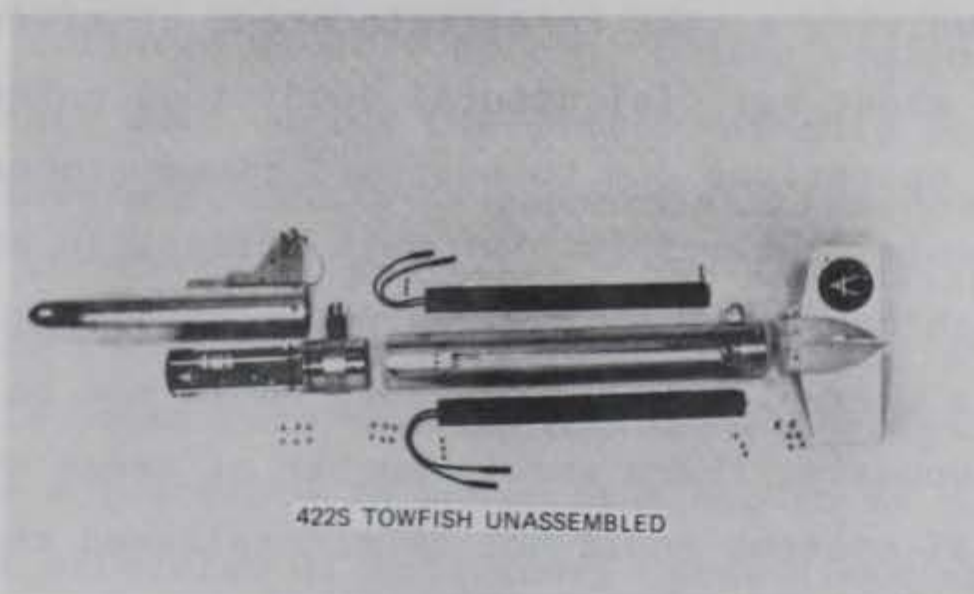

422S TOWFISH UNASSEMBLED

Figure 42. Basic components of the Klein Hydroscan side-scanning sonar system (courtesy of Klein Associates, Inc.)



## Selection of Study Areas

### Applicability to project objectives

133. Every effort was made to select study areas where the performance of the acoustic profiling systems and resultant acoustic data collected would be of value to the Section 32 Program objectives. This rationale, for the most part, was relatively easy to maintain at the working level of the study because most fluvial environments within the United States are characterized by varying degrees of bank and channel erosion. In addition to the foregoing rationale, survey site selection was also based, when possible, on the needs of various Corps of Engineers district offices for data that would be of value to ongoing or future streambank erosion projects.

134. At the inception of the study it was envisioned that the evaluation of the various acoustic profiling systems would be accomplished at site-specific locations where a major bank problem or proposed bank protection project was located. However, this approach was expanded to provide more coverage over a wider range of channel environments and conditions. It was thought that this approach would result in a more realistic evaluation of the survey equipment and provide a more interesting array of bottom and subbottom acoustic data.

### Accessibility to survey areas

135. Study area selection was tempered by problems of accessibility. Problems involving access to certain areas of river systems were primarily brought about by: (a) natural conditions unfavorable to the conduct of survey operations due to weather, river stages, and other physical/environmental parameters that were present in area; (b) ongoing litigation in which the Corps of Engineers was involved; and (c) remoteness of some areas where logistical support could not be effectively organized. Consequently, there were a number of areas where the application of geophysical systems could not be accomplished that would have resulted in additional data in support of the project. In most instances, Corps of Engineers district offices were consulted prior to final selection of study areas located within the district boundaries.



Corps district personnel furnished timely and required data concerning numerous characteristics and descriptions of the proposed study areas. This information facilitated the selection of specific areas where application of the survey systems were to be employed.

#### Physical and environmental characteristics

136. While the primary purpose for selection of study areas was to evaluate the acoustic profiling systems for use in streambank erosion studies, there were secondary interests concerning the type of general data that could be acquired in fluvial environments by use of these systems. Therefore, attempts were made to provide a wide range of physical and environmental conditions for testing of the survey equipment. For example, areas were chosen that would provide a realistic opportunity to delineate bedrock formations underlying large areas of river systems in the United States, i.e., the Ohio River. Since bedrock formations play an important role in controlling channel scour and degradation, some study areas were chosen where available information indicated bedrock to be at relatively shallow depths below the river channel.

#### Availability of support equipment and personnel

137. An important factor in selection and location of study areas was the availability of support equipment and personnel for the field operations. Survey boats were probably the most important type of support equipment, followed closely by positioning equipment. Nearly all of the survey boats used during the conduct of this study were furnished by Corps of Engineers districts or commercial firms whose boats were under contract to the Corps of Engineers. The nonavailability of boats affected the selection of study areas and scheduling of surveys somewhat. However, suitable boats were usually available throughout the period of the study. Some adjustments in scheduling had to be made to avoid conflicts with work schedules of individual Corps districts. These adjustments sometimes resulted in conducting the survey when river stages or weather conditions were not favorable for optimum acquisition of acoustic data. However, most surveys were scheduled for optimum times of the



year when overall conditions were conducive to the requirements of acoustic profiling techniques.

138. The Corps districts were also helpful in supplying the required support personnel for the duration of the surveys. Most of these personnel consisted of survey boat crews, survey personnel, and individuals familiar with the river system to provide assistance in locating fuel, docking space, and other logistical support as required.

### Data Interpretation Procedures

#### Management of acoustic survey data

139. As the result of acoustic profiling surveys conducted on the Mississippi, Missouri, Ohio, and White Rivers in support of the Section 32 Program, a large amount of CSRP and side-scanning sonar data was acquired and available for data analysis. Each acoustic survey was planned so that a reasonable period of time was scheduled between surveys to allow ample time for the preparation and interpretation of the acoustic data. The period of time required for interpretation of acoustic data depends primarily on the amount of data and the complexity of the data. However, the quality of the survey data and availability of ground truth data from other sources are also additional factors involved in the length of time required for acoustic record interpretation.

#### Rationale of approach to data interpretation

140. The principal approach used during the data interpretation phases of this study was to evaluate the acoustic data in terms of its value to streambank erosion studies. It became increasingly apparent as data interpretation progressed that a significant amount of information concerning additional applications of the technique was being collected. It is thought that most parameters that are detectable utilizing acoustic survey systems in fluvial environments are either directly or indirectly involved in channel erosion processes. However, it is assumed that even those parameters not clearly involved in streambank erosion are, in some manner, important to other aspects of channel management



studies. For this reason, some data shown and discussed in subsequent portions of this report, while possibly not directly relevant to stream-bank erosion processes, are felt to be of significant value to studies of fluvial environments, particularly those within the CE mission framework.

141. Natural and man-made features and processes generally present in fluvial environments are tabulated below. These parameters were target features for the evaluation of the acoustic profiling systems used in support of this study.

a. Geologic parameters

(1) Stratigraphic discontinuities

Sediment/rock contacts  
Rock outcrops  
Sediment/rock thickness, depth, and areal extent  
Sediment/rock bedding characteristics

(2) Lithology

Sediment/rock classification  
Sediment/rock density

(3) Geologic structures

Faulting  
Folding  
Jointing/fracturing  
Unconformities

b. Hydraulic/hydrologic parameters

(1) Channel geometry

(2) Bedforms

(3) Degradation/scour

(4) Aggradation/accretion

(5) Subaqueous bank/slope failures

Slumping  
Sliding/flow

(6) Turbulent zones

c. Hydraulic/stabilization structures

(1) Training structures

Dikes  
Groins



(2) Bank protection structures

Revetments

(3) Foundation structures

Piers

Cassions

Piling

(4) Wrecks and debris

d. Miscellaneous

(1) Pipelines

(2) Wrecks and debris

(3) Abandoned structures

(4) Cultural resources

142. The data interpretation phases of this study actually began while the acoustic survey was underway at the field sites. A great deal of useful information could normally be obtained as real-time data were displayed. This is particularly true of the side-scanning sonar data where the interpretation of many features appearing on the record was facilitated by visual observations of specific sites or features related to the bottom features detected by the system. Activities, i.e., boat traffic, common sources of spurious data signatures on the acoustic record, were carefully noted on the records. Although subbottom data are less responsive to field interpretations, careful observation of shore features often provided significant clues for the identification of seismic reflections appearing on the records. For example, a strong acoustic reflector which increases in elevation as the shoreline is approached, where rock outcrops are located, could reasonably be assumed to be an extension of the rock formation dipping below the channel bottom. While these initial assumptions are later weighed in light of all available information, any information gathered in the field during the conduct of the surveys was integrated with other sources of background data collected during the study.

Correlation of  
acoustic and ground truth data

143. When available, soil and rock boring logs were useful in



attaining correlations between acoustic reflections appearing on the CSR data records and logged thicknesses, depths, and distribution of soils and rocks in the subsurface of the survey areas. Boring locations were located on topographic maps or aerial photographs were used as survey line base maps for a particular survey area. While the borings identified subsurface sediment and rock formations at specific points, they were, unfortunately, too few and too widely distributed to be of value over the entire survey area. However, at certain points within the survey area borings provided excellent correlation between the subsurface conditions and the acoustic data. These borings were located primarily at bridge crossings, locks and dam sites, and miscellaneous construction sites. In most instances reasonable correlations were attained. Perhaps the most useful correlations derived from the boring logs were the identification of the top of bedrock or older alluvial horizons.

#### Accuracy levels of acoustic data interpretation

144. The acoustic profiling technique has been demonstrated to be a reliable exploration tool through a wide range of applications over the last two decades. It would be less than realistic to state, however, that the method does not have its limitations, particularly with regard to data interpretation. Accurate and reliable data interpretations require a combination of personnel skills and experience, background data, ground truth data, and onsite data acquisition expertise. Experienced acoustic data interpreters point out that experience gives personnel a "feel" for making interpretations that is initially lacking. Advances in data processing equipment and computer techniques, particularly within the petroleum industry, have facilitated the processing and interpretation of seismic data to an advanced state. However, these capabilities are not always available to all organizations which use the waterborne geophysical technique.

145. Ground truth data are needed for acoustic data correlation if a high level of interpretational accuracy is achieved. It is possible to identify some physical features without correlative ground truth data identified because of characteristic shape and pattern, i.e., old



stream channels. Although the acoustic signature of features will normally be somewhat exaggerated or distorted, reflections from geologic structure, i.e., faulting, are generally identifiable due to interpretative keys as offset or displacement of bedding planes. Probably the most difficult interpretation to make from CSRP records in absence of correlative ground truth data is lithology.

146. Identification of channel bottom parameters with side-scanning sonar is largely dependent on shape, pattern, texture, and tone of the target. Accuracy of interpretations can range from high to very low, depending largely on the objective of the survey. Familiar objects, i.e., boats, aircraft, automobiles, and pipelines, and natural features, i.e., sand waves, and rock outcrops, generally exhibit reliable recognition keys, depending on range of the target, record scale, and record quality. Accurate interpretation of side-scanning sonar data must consider the problem of the effects of lateral and on-line distortion resulting from differences in the towfish elevation relative to the channel bottom and variations in the survey boat's survey track and speed. Rarely will an object or feature located on the channel bottom display its true geometric dimensions on the side-scanning sonar record display. New side-scanning equipment presently being introduced includes microprocessing circuitry which provides automatic correction for slant range distortion and distortion due to variations in the survey boat's speed. These improvements in the side-scanning sonar technique should provide greater state-of-the-art capability for bottom data acquisition and should facilitate the task of data interpretation.

#### Presentation of Selected Acoustic Survey Data

147. The examples of acoustic profiling data and interpretations presented in the following portions of this report were selected using the following guidelines:

- a. Relevance of data to project objectives.
- b. Representative distribution among geographical locations of acoustic survey areas.



- c. Interest expressed by CE District organizations and other organizations outside of the CE.
- d. Data best illustrative of acoustic profiling technique that could be applied to other ongoing or future CE geologic and engineering investigations.
- e. Quality of acoustic profile data.

### White River Survey Sites

#### Location

148. Two sites, located on the White River at Des Arc and Augusta, Ark., were selected for study because of severe bank erosion problems at the sites and at the request of the Memphis District, CE. The town of Des Arc is located on the west bank of the White River at about River Mile (RM) 143. Augusta is located north of Des Arc at RM 193 on the east bank of the river. Both sites are situated in east-central Arkansas, approximately 90 miles west of Memphis, Tenn. (Figure 43).

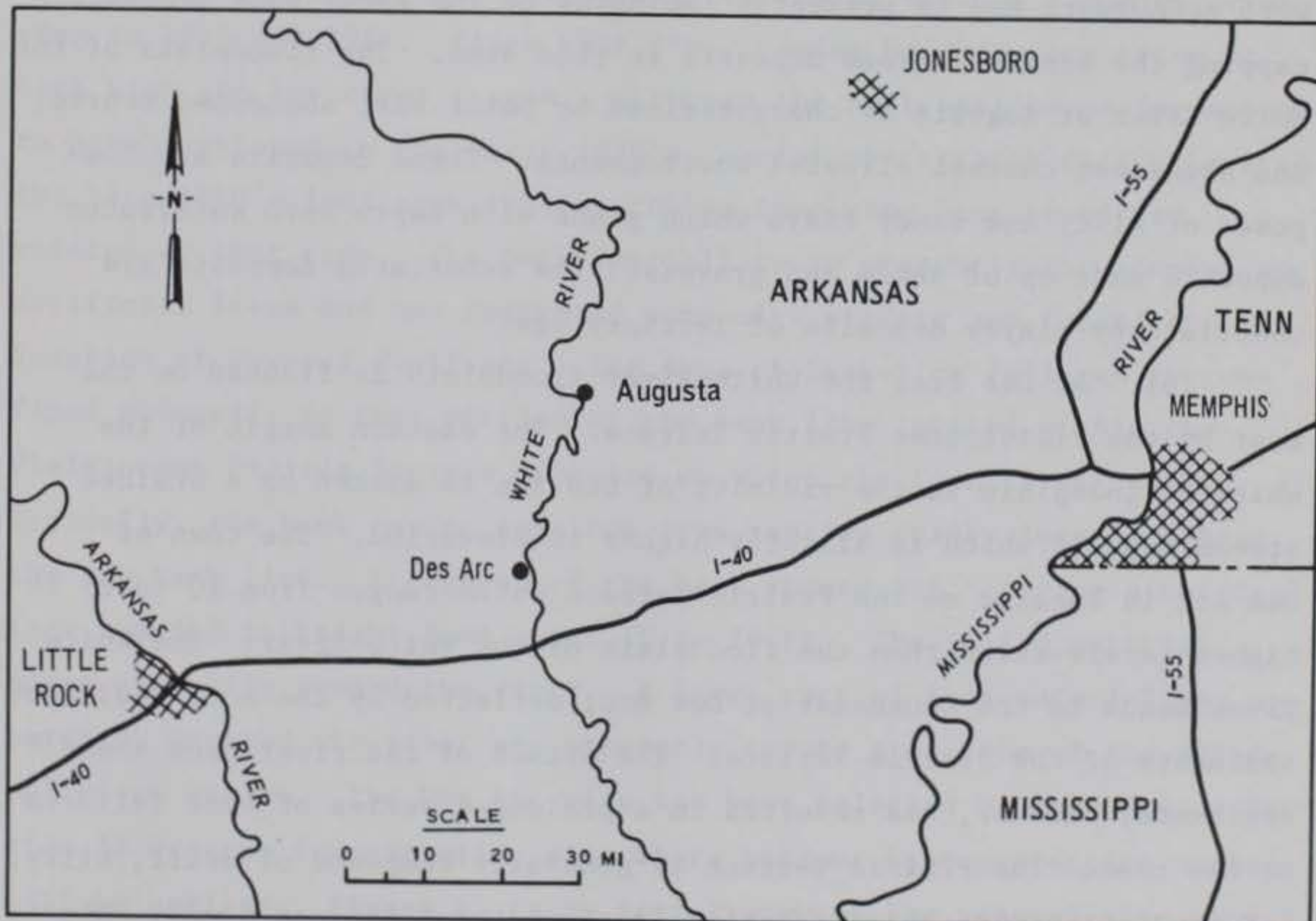

Figure 43. Site location map, White River acoustic survey sites



Physiographic and  
geological setting

149. The Des Arc and Augusta survey sites are located within the floodplain environment of the White River in the physiographic division of the Lower Mississippi Valley known as the Western Lowlands. The Western Lowlands, situated between Crowleys Ridge on the east and the Ozark Escarpment on the west, slopes to the south where it intersects the present Mississippi River meander belt southwest of Helena, Ark. (Saucier and Smith 1971). The lowest relief generally occurs in the White River alluvial plain. However, the surface is broken by a number of higher landforms composed principally of terraces created by the down-cutting and progressive westward shifting of braided stream environments that deposited the major portion of the lowland sediments.

150. The town of Augusta is situated on a braided stream surface of Pleistocene/Recent age. The White River is slowly migrating eastward at Augusta and is presently impinging on the sandy dune deposits capping the braided stream deposits in this area. The floodplain of the White River at Augusta is characterized by point bar, abandoned course, and abandoned channel alluvial environments. These deposits are composed of silty and sandy clays which grade with depth into substratum deposits made up of sands and gravels. The substratum deposits are underlain by clayey deposits of Tertiary age.

151. At Des Arc, the White River floodplain is flanked on the west by the Pleistocene Prairie Terrace. The eastern margin of the White's floodplain in the vicinity of Des Arc is marked by a braided stream deposit which is slightly higher in elevation. The town of Des Arc is located on the Prairie Terrace which ranges from 10 to 25 ft higher in elevation than the floodplain of the White River. The White River bends to the southeast at Des Arc, deflected by the more resistant sediments of the Prairie Terrace. The attack of the river upon these sediments, however, has resulted in a prolonged series of bank failures at the town. The Prairie Terrace is generally composed of stiff, silty, and sandy clays interbedded by lenses of softer silts and sands. The terrace deposits are underlain by substratum deposits composed of



Pleistocene sands and gravels. The White River floodplain at Des Arc is relatively narrow, ranging from about 1.5 to 3 miles in the general vicinity of the town. The floodplain is generally composed of point bar and abandoned channel environments characterized by predominantly silty, sandy clays, and silty clays, respectively. Areas of braided stream environments, composed generally of silty and sandy clays and veneered irregularly with surface deposits of windblown sand dunes, are located along the eastern margins of the White River alluvial plain in the vicinity of Des Arc. A small area of braided stream deposits occur just downstream of Des Arc, between the White River and the Prairie Terrace escarpment. The Recent floodplain alluvium is underlain by substratum deposits of Recent and late Pleistocene age. These deposits grade into the Tertiary formation.

#### Background of bank erosion problems

152. Bank caving at Des Arc, affecting about 1500 ft of the western bank line (Figure 44), intensified following serious flooding occurring in 1973 and 1974. Since that time, caving has been occurring at both high and low river stages. Although the most serious caving appears to have developed in the early 1970's, aerial photography dating back to the late 1940's indicates that a problem involving bank stability existed at that time. The bank instability is presently threatening an artificial levee and has destroyed some city streets and forced the relocation of several dwellings. The area of bank-line failures is confined primarily to that portion of the bank line located within the Pleistocene Prairie Terrace deposits on which the town is situated. Typically, the bank caving develops from tension cracks located behind the top bank line. A segment of the bank shears off, leaving a vertical face ranging in height from about 10 to 20 ft. The failed material moves gradually toward the river. A large part of this material has apparently entered the river and presently covers a section of the original river bottom. The Des Arc site has been selected by the CE as a Section 32 Program demonstration site where various bank protection methods will be applied. Figure 45 is an aerial view of the general site area at Des Arc. An aerial view of a part of the affected west bank line





Figure 44. Aerial photograph of the Des Arc, Ark., acoustic survey site (Actual survey site is within inset.)

showing the characteristics of the bank failure is shown in Figure 46.

153. The bank caving at the Augusta site, while not as serious as the Des Arc site, is generally more extensive and is threatening private and commercial property along the eastern bank line. Apparently, the caving bank line is attributable to the situation of Augusta along the outside bend, or cut bank side, of a large meander loop of the White River (Figure 47). Consequently, the greater part of the river's



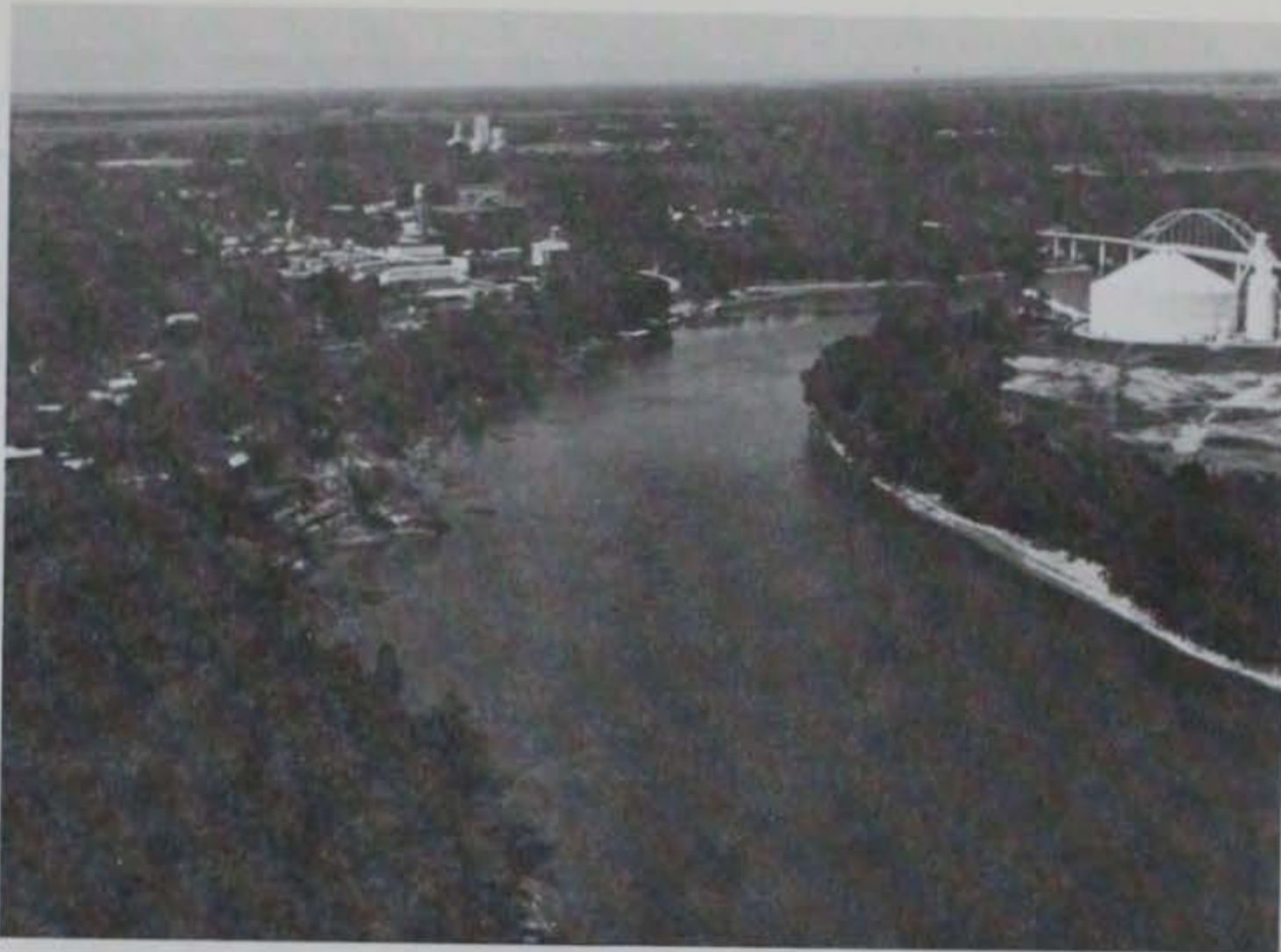

Figure 45. Low altitude view of the Des Arc survey site, view to the northwest, looking upstream (Major portion of bank failure can be seen in left foreground of photo; from Memphis District, CE.)



Figure 46. Aerial view of bank-line failure at a point along west bank line of White River at Des Arc, Ark., view to the east (from Memphis District, CE)





Figure 47. Aerial photograph of the Augusta, Ark., acoustic survey site (Actual survey site is within inset.)

energy is directed against the bank line along which the town has developed. An additional factor involved in the bank erosion problem at Augusta is the erodibility of the sediments composing the bank line. The bank line is generally composed of soft sandy silts and clays interbedded by silty sands. The bank line displays differential erosion in that some portions of the bank are retreating at a greater rate than other portions. This effect is due to the variation in bank sediment composition with the coarse sediment fractions eroding at a higher rate.



Aerial photography dating back to the 1940's indicates similar conditions along the outside bend of the channel at Augusta. The photography also indicates that the bendway has been slowly migrating eastward toward the town. Figures 48 and 49 are representative views of the general site area and the nature of the bank-line erosion, respectively. Attempts to halt bank erosion along the eastern bank of the White River downstream of the town through the use of junk auto bodies is shown in Figures 50 and 51.

#### Implementation of survey

154. Survey operations at the Des Arc and Augusta, Ark., sites were conducted during the period 19 to 27 September 1977. Because the two sites were within the boundaries of the Memphis District and due to the interest in resolving the bank failure problems at Des Arc, the Memphis District furnished assistance to the WES in form of survey equipment and personnel in support of the site surveys. A description of the surveys conducted at the White River survey sites is contained in the following paragraphs.

155. Support equipment and personnel. The Memphis District, CE furnished a 35-ft survey boat, the ARC; positioning equipment; and operating personnel in support of the acoustic profiling survey. The ARC (Figure 52) contained an array of electronic positioning equipment, a portion of which was used to plot the track of the survey boat at the sites. The boat's survey fathometer was used to obtain accurate water depth measurements and channel bottom profiles during the survey. The horizontal control requirements during the survey were accomplished using the range-azimuth positioning technique. Components of a Motorola Mini-Ranger microwave positioning system and optical instrument were used in support of the positioning portion of the survey. Figure 53 shows the T/R and instrument configuration used on the shore at Des Arc, Ark.

156. Acoustic survey systems used. The principal acoustic profiling system utilized at the Des Arc and Augusta survey sites were the EG&G Uniboom and the ORE Model 1098 side-scanning sonar systems. As mentioned above, the survey fathometer aboard the Memphis District, CE





Figure 48. Aerial view of the Augusta, Ark., survey area, view toward the north (from Memphis District, CE)



Figure 49. A segment of bank line along the east bank of river at Augusta, Ark. (from Memphis District, CE)





Figure 50. Bank-line protection measures undertaken by local interests along a portion of the east bank of the White River just downstream of Augusta, Ark.



Figure 51. Aerial view of east bank of the White River downstream of Augusta, Ark. (Junked car bodies shown in Figure 50 are located in this area; view is to the north; from Memphis District, CE.)





Figure 52. U. S. Army CE survey boat, the ARC, furnished by the Memphis District, CE, in support of the White River acoustic surveys

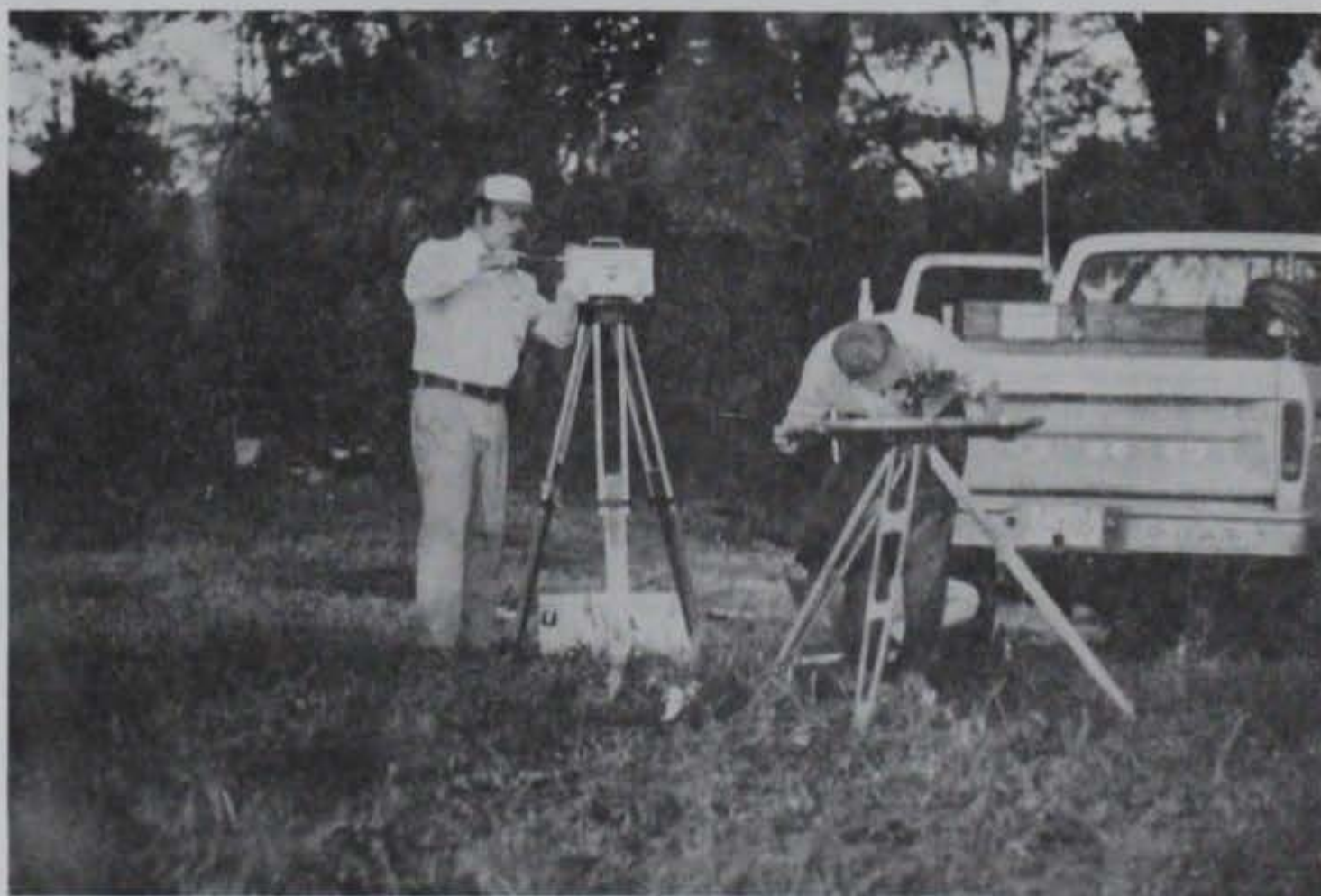

Figure 53. Shore components of the positioning system used for horizontal control of acoustic profile lines at Des Arc and Augusta, Ark.



survey boat was used for navigation and bathymetric control. Because of the shallow depths of water (10 to 35 ft) which existed over most of the survey area the Model 262 single-element hydrophone was used as the receiving component of the Uniboom profiling system.

157. Configuration and characteristics of the survey sites. At Des Arc, the survey site was delineated roughly by the present highway bridge on the north and by the former position of the old highway bridge on the south (Figure 54). The channel at the Des Arc survey site ranges

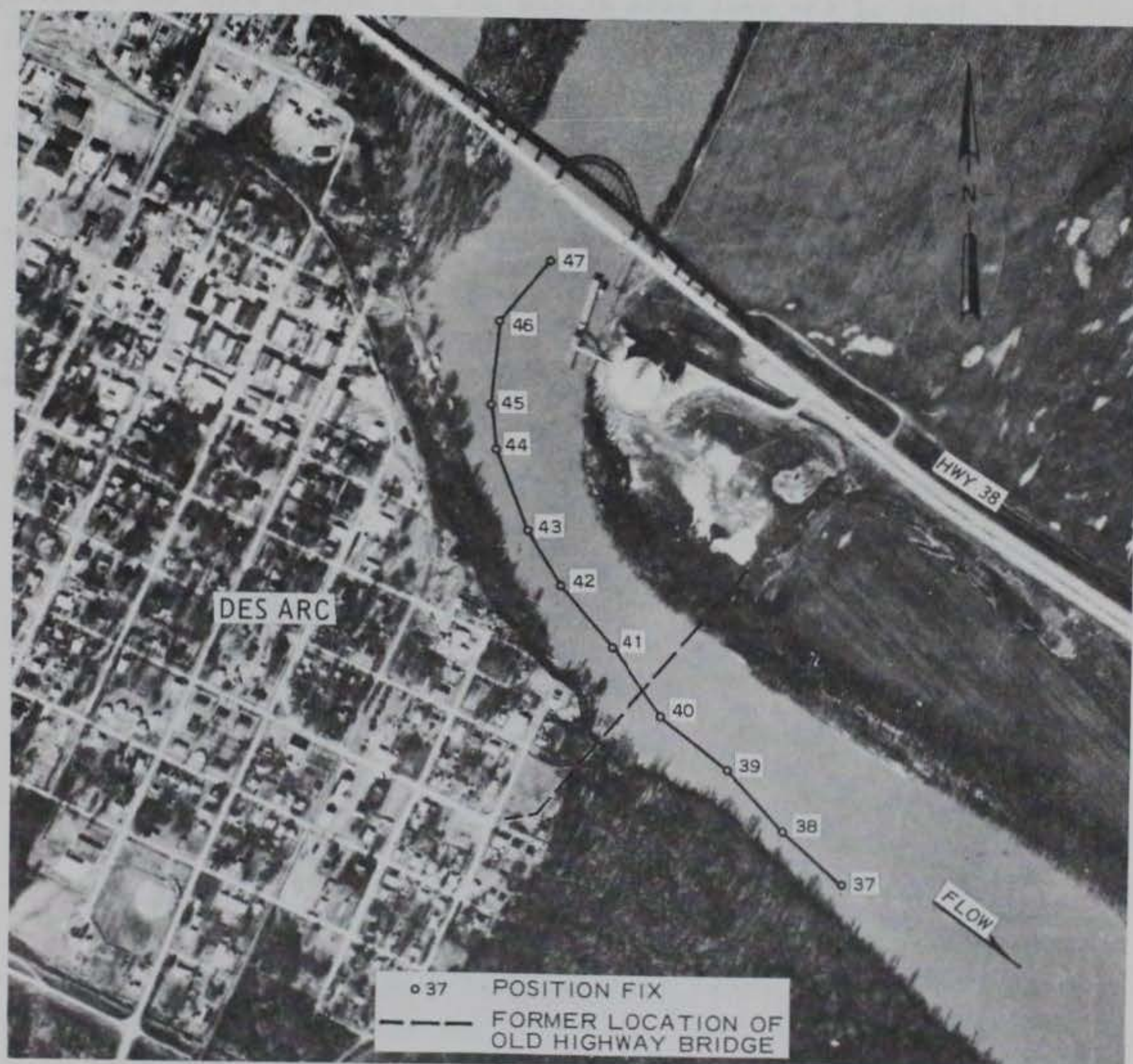

Figure 54. Position of representative acoustic survey line at the Des Arc, Ark., survey site on the White River; scale, 1 in. = approximately 800 ft



in width from approximately 600 ft near the new highway bridge to about 350 ft near the site of the former highway bridge. Deepest portions of the channel within the survey site occur on the downstream side of the remains of an old concrete pier associated with the old highway bridge. Maximum water depth at this point was approximately 40 ft at the time of the survey. The western bank line of the survey site flanks the channel thalweg, or deepest portion of the channel. Water depths along the bank line ranged from 30 to 35 ft during the survey.

158. Most of the west bank at the Des Arc survey site was actively caving at the time of the survey. A large mass of failed material could be observed at the base of a vertical bank extending from the bank approximately 300 ft to the water's edge. The mass of failed material was characterized by a gradually sloping surface toward the river and was covered with vegetation and trees that had caved with the material. Portions of paved streets could also be observed at various points on the surface of the slide material. The streets and a few small buildings had collapsed along with the bank material as the bank erosion progressed at Des Arc. Figure 55 is a view of the affected bank line as seen from the survey boat during the conduct of the acoustic survey at Des Arc.



Figure 55. Section of the west bank at Des Arc, Ark., where active bank failure is occurring (The white frame house in the left center of the photograph can also be seen in the aerial photograph in Figure 46.)



159. At Augusta the portion of the White River channel located within the survey site is characterized by relatively uniform channel geometry. The width of the channel is approximately 450 ft and water depths ranged from about 10 ft to slightly over 20 ft during the survey. At the time of the acoustic survey, it was observed that the east bank of the channel in the survey area was actively eroding. The bank erosion, however, was not nearly as serious as that observed at the Des Arc site.

160. A gradual rise in river stage occurred during the survey period at both the Des Arc and Augusta survey sites. The stage at Des Arc increased from 4.8 ft to 9.3 ft within a 6-day period. Some minor problems were experienced due to driftwood introduced into the river by the rising water levels.

161. Availability of background and ground truth data. The following listed background and ground truth data were available for preplanning, postsurvey analysis, and use during the acoustic survey at Des Arc and Augusta, Ark.:

- a. Aerial photography. Aerial photography held by the U. S. Department of Agriculture (USDA) and the CE was obtained for use during the survey and for correlative study of the bank erosion problems at the survey sites. The photography ranged in scale from approximately 1:10,000 to 1:40,000 with the prevalent scale being 1:24,000. The photography was limited to 5-year or more increments in an attempt to limit the amount of photography required and to provide more conspicuous comparison of physical, cultural, and environmental changes occurring over a period of years. The earliest photography available was taken in the late 1930's. The latest coverage utilized during the study was acquired in 1975. All of the vertical aerial photography was standard panchromatic type. A small amount of low-altitude 35-mm color photography obtained with handheld cameras was acquired from the Memphis District, CE for use during the study. This photography was confined primarily to the immediate site areas at Des Arc and Augusta.
- b. Maps and charts. A number of various maps and charts were used in support of the survey and subsequent data analysis. Topographic quadrangle maps produced by the U. S. Geological Survey (USGS) at a scale of 1:24,000 were available for the Des Arc and Augusta survey sites.



Engineering geology maps at a scale of 1:62,500 produced by WES were useful in determining surface and subsurface geological environments at both of the survey sites. The only bathymetric data available for pre-survey planning was in the form of a reconnaissance survey of the White River conducted by the Memphis District, CE in May 1977 from Batesville, Ark., to the mouth of the White. The bathymetric data was applied to copies of 1975 aerial photography along the course of the White River at a scale of 1:10,000.

- c. Soil borings. Logs and laboratory analyses of borings drilled at the Des Arc site in 1975, 1977, and 1978 have been made available by the Memphis District, CE for use during the conduct of this study. All of the borings, with the exception of one, were located on the top bank of the site. One boring was drilled into the mass of material between the top bank and the river's edge. The deepest boring extends to a depth of 97 feet below the surface of the top bank. Borings drilled in the channel for foundation investigation prior to construction of Arkansas Highway 38 bridge at Des Arc could not be obtained for use during this study. Shallow borings drilled along the eastern approach to the bridge were available, but were not useful due to their shallow depth. No soil borings were available for the Augusta survey site.
- d. Miscellaneous. There is little published information concerning the White River and survey sites at Des Arc and Augusta. However, several internal documents prepared by personnel of the Memphis District, CE were helpful in understanding the background of problems involved in the bank failure at Des Arc and, to a lesser extent, at Augusta. This documentation consisted primarily of memoranda for record describing visits to the affected sites and proposed remedial action to be taken by the CE. Correspondence between local, state, and federal organizations concerning the problems at Des Arc and Augusta were also available for review during the conduct of the study. In addition, personal communication with individuals residing in the area of the survey sites provided information concerning physical and environmental parameters of the survey sites that only one living in close proximity to the sites over a prolonged period of time could provide. Such information was extremely helpful during the acoustic survey and data analysis phases of this study.

162. Survey procedures. Acoustic survey operations on the White River were initiated at the Des Arc survey site on 20 September 1977.



As previously mentioned, the WES boomer subbottom profiler and ORE side-scanning sonar system were utilized at Des Arc and Augusta survey sites. Since the primary purpose of the survey at Des Arc was to evaluate the survey systems for determining and monitoring bank erosion parameters, the area of the survey was concentrated on that portion of the west bank line at Des Arc that was subjected to severe bank failure. The boomer and side-scanning systems were generally operated simultaneously throughout the survey with the exception of the final day of surveying at Des Arc when only the side-scanning system was used. Approximately 25 profile lines were obtained at various positions in the channel between the new highway bridge and the location of the old highway bridge. The location of a representative profile line is shown in Figure 54 with position fix points plotted along the line of profile. Because of the generally shallow water depths of the river channel at Des Arc and the restricted width of the channel, the boomer source and hydrophone were towed close beside the hull of the survey boat. The source and hydrophone components were separated approximately 6 ft horizontally.

Figure 56 shows the boomer towing configuration used at both the Des Arc and Augusta survey sites. The side-scanning sonar towfish was towed from the stern of the survey boat at a depth of approximately 10 ft below the surface of the water.

163. The horizontal control of each profile line was accomplished by survey personnel of the Memphis District, CE using a combination of electronic ranging components and a transit. T/R's located on the boat and bank provided a continuous update of distance from a surveyed point on the bank to the boat. The transit was used to "cut" angles at frequent intervals along the survey line. Radio communication between the survey boat and the personnel on shore provided position mark fix intervals at the command of the survey party on shore. Acoustic equipment operators marked the respective records at each position fix command. Since the positioning technique and equipment utilized at Des Arc and Augusta were limited to line-of-sight operation, placement of the equipment on shore at known survey coordinates governed the total area that could be positioned accurately at each site.



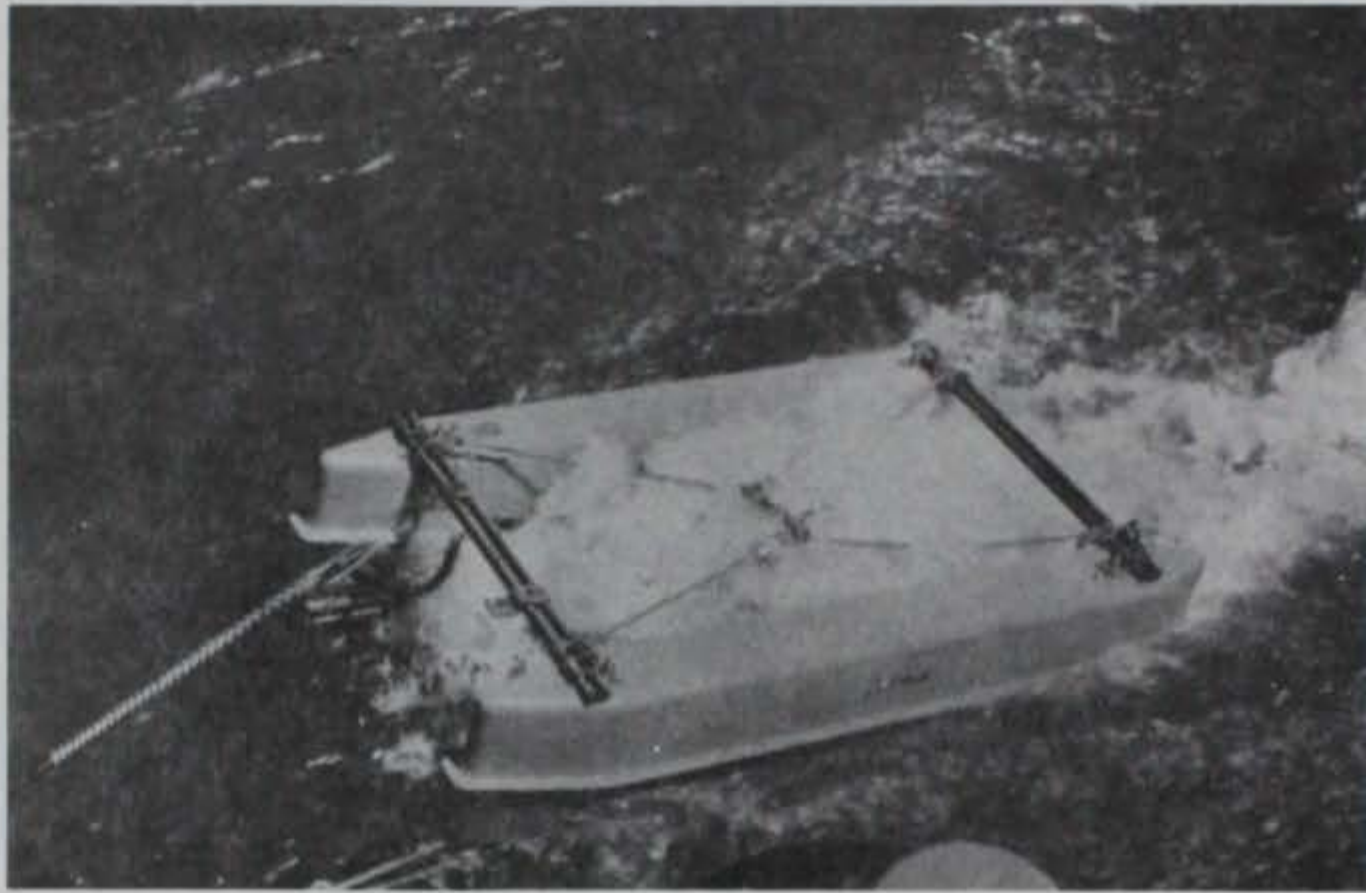

Figure 56. Towing configuration of the WES EG&G Uniboom source and receiving components used at the White River survey sites (The hydrophone is just visible in the top left of the photo; the quarter stern of the survey boat is at the extreme bottom of the photo.)

164. Acoustic profiles were obtained at various horizontal distances from the west bank at Des Arc in both an upstream and downstream direction. The upstream tracks appeared to offer somewhat better system performance and boat control although the current velocities were not significantly high throughout the survey period. Since deepest water depths were located in the channel thalweg, it was attempted to stay within the thalweg zone for each profile. The upper and lower extremities of the survey lines, however, were usually located in crossings of the channel which were characterized by shallow water depths of 8 to 10 ft.

165. At Augusta, similar towing arrangements were used for the acoustic survey systems and the same positioning techniques and equipment were also employed. Survey operations at Augusta were conducted on 23 and 24 September 1977. Fewer profile lines were acquired at the Augusta site because of the greater length of the portion of the channel surveyed. Although the major effort of the survey operations at Augusta were concentrated along that part of the channel contiguous with the



town, a few lines were run as far downstream as the Missouri Pacific Railroad bridge and upstream to a point just downstream of the U. S. Highway 64 bridge.

166. Because of the rather narrow width of the White River channel at Des Arc and Augusta, traverses across the channel perpendicular to the channel axis could not be accomplished. However, the nature of the bank erosion at both sites was such that profile data oriented across the channel profile were not required. Consequently, all of the profile lines obtained at the White River survey sites are parallel, or essentially parallel, to the channel banks.

167. Data analysis. The results of the acoustic profiling surveys conducted at Des Arc and Augusta, Ark., were considered satisfactory in terms of the quantity and quality of data obtained. Penetration of the White River channel bottom was intermittent at both sites. Fortunately, the Uniboom system was able to achieve a maximum of 35 ft of penetration of the channel bottom in the immediate area of the bank failure at Des Arc. At Augusta, penetration of the bottom was limited, occurring only in a few areas of the survey area. Maximum penetration of the bottom was about 25 ft. The impact of shallower water depths at the Augusta site probably hampered system performance. However, a more likely explanation is that the intense multiple reflections of the bottom, closely spaced due to the depth of the water, may have obscured the subbottom reflections. The side-scanning sonar system worked well at both sites and provided detailed records of channel bottom topography. Some difficulty in keeping the side-scanning towfish from striking the channel bottom was encountered due to the variability of water depths prevalent at the survey sites. Examples of the acoustic data obtained at Des Arc and a discussion of the data follow below.

168. CSRP data. The profile (Figure 57) shows an irregular mass of failed bank material (I) that has slumped into the thalweg of the White River channel at Des Arc. The former channel bottom (C) is delineated by the single-line reflection signature that extends from the position of the old highway bridge pier (H) to the strong initial bottom multiple (D) near the right margin of the profile. The remains of



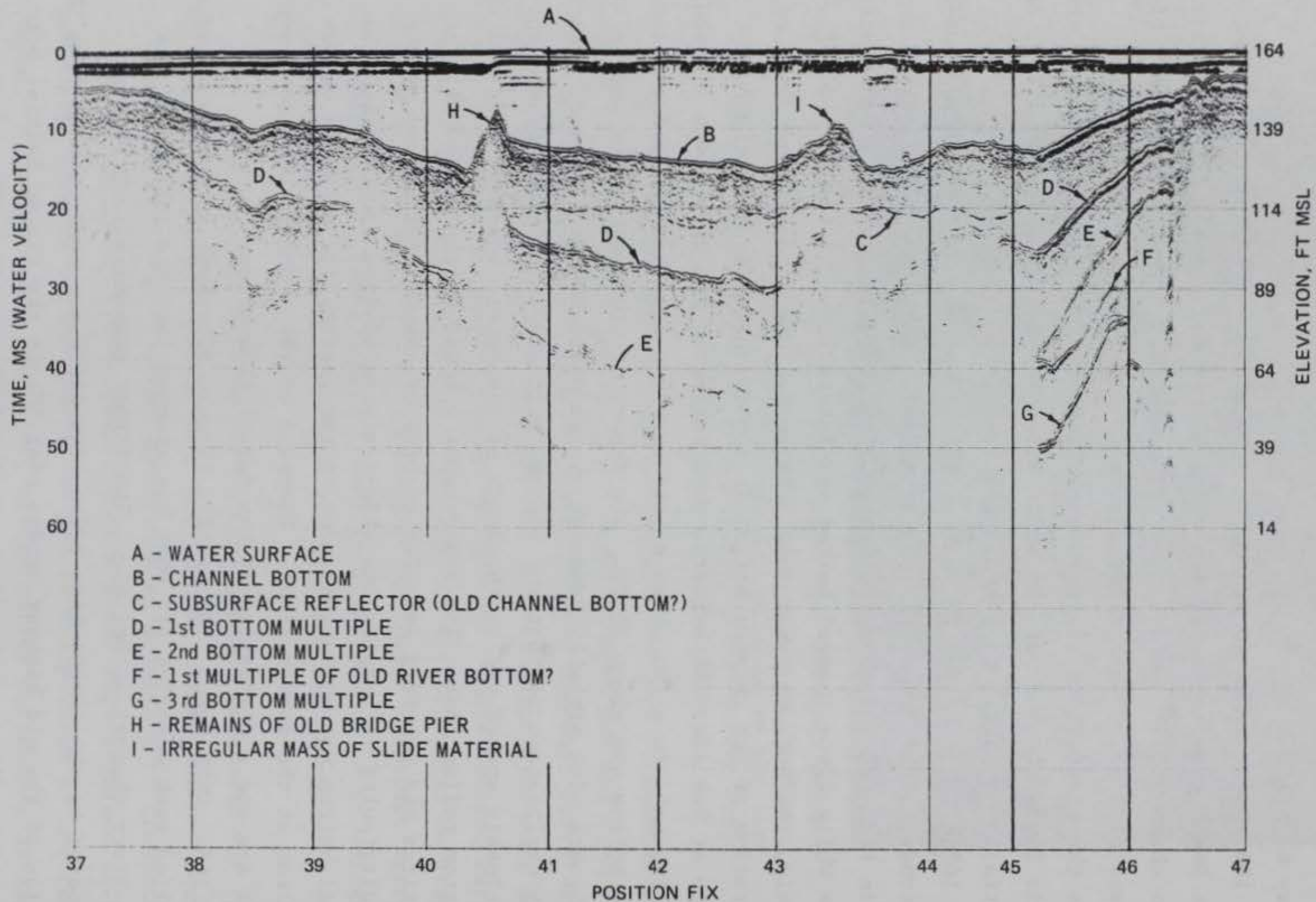

Figure 57. Boomer acoustic profile record, Des Arc, Ark., survey site, White River  
 (Horizontal scale is 1 in. = 450 ft approximately.)



the bridge pier (H) apparently act as a barrier to the movement of sediment in a downstream direction (to the left on the record). A large scour hole is located on the downstream side of the remains of the old highway bridge pier. As seen in the aerial photograph of the survey site in Figure 54, the area of scour has extended into the west bank at the point where the old bridge intersected the bank line. A large, semi-circular area of the bank line has been eroded away. The acoustic reflection identified as the position of an older channel bottom (C) on the acoustic record coincides within a few feet in elevation to the surface of a gravel layer of unknown thickness that was encountered in a boring located opposite position fix number 41 and about 20 ft landward from the present top bank of the river. It is possible that the older position of the channel thalweg bottom was in the gravel material. The boring at Des Arc encountered silty sand at elevation 148 ft mean sea level (msl) which extended to the gravel formation at approximately elevation 110 ft msl. Probably the location of the highly erodible sand in the vicinity of the toe of the bank at Des Arc has been a major factor in the history of bank failures there. Scouring of the sand by the river results in the undermining of the top-stratum deposits at the site and slumping of the bank line occurs. The mass of failed bank material presently in the thalweg at Des Arc may actually provide some measure of protection from scour since the material may have covered the sand deposits located at the toe of the bank. The water surface is at (A), multiple reflections at (E), (F), and (G). Figure 58 is a geologic interpretation of the boomer record shown in Figure 57.

#### Results of survey

169. The acoustic survey performed at Des Arc identified and validated the presence of the toe of a large mass of failed bank material in the White River channel. It is possible that the acoustic survey techniques used at Des Arc could have detected the early evidences of a deep-seated, underwater failure zone before indications of the failure manifested itself in the subaerial portions of the bank line.



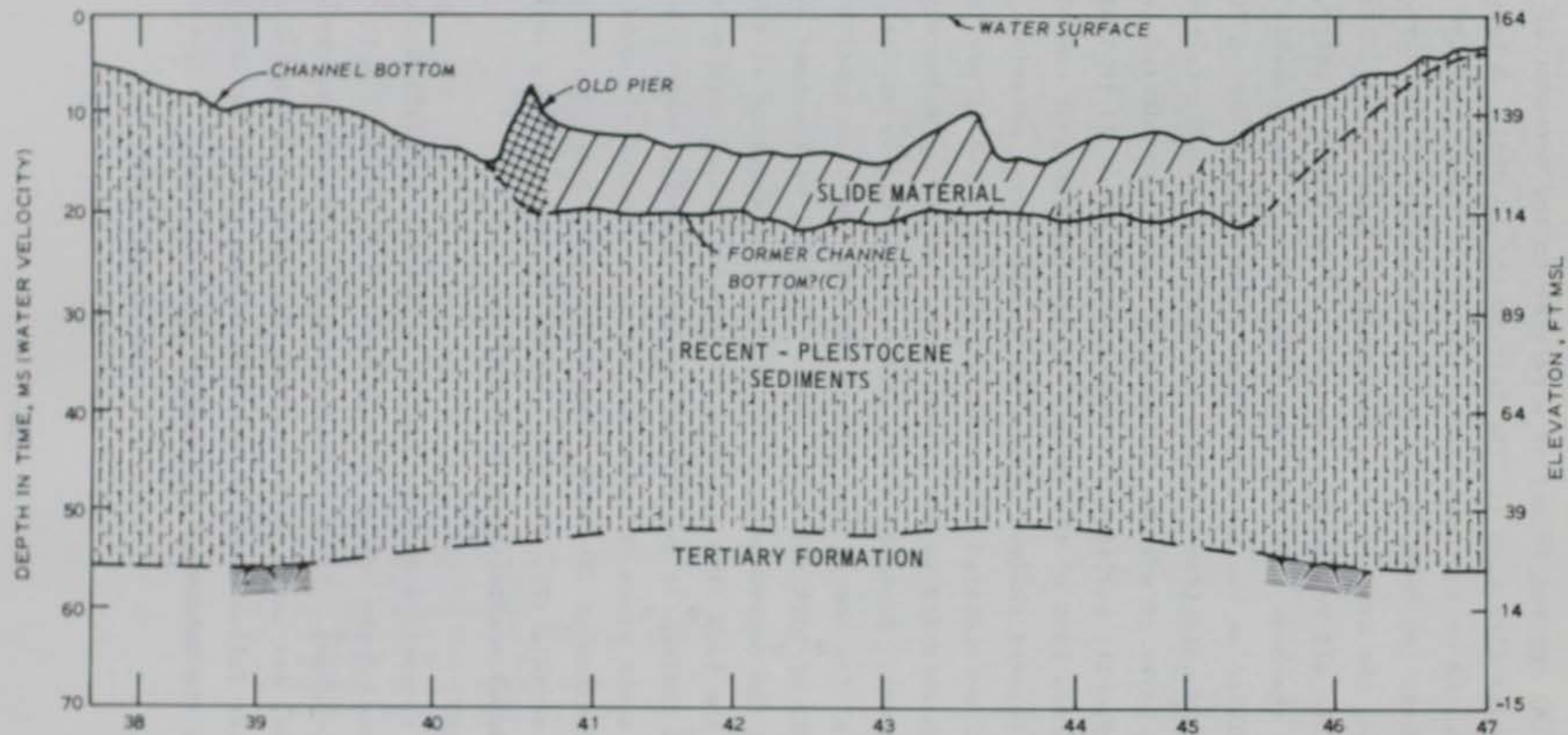

Figure 58. Geologic cross section along survey line based on boomer acoustic profile record obtained at Des Arc, Ark., survey site, White River (Horizontal scale is 1 in. = 400 ft approximately; delineation of Recent-Pleistocene and Tertiary contact is based on other sources of data.)



## Lower Mississippi River Survey Sites

### Location

170. Acoustic profiling surveys were conducted in two reaches of the Lower Mississippi River as part of this study. One area is located between RM 420 and 430 downstream from Vicksburg, Miss., and the second survey area is located between RM 563 and 575 near Arkansas City, Ark. (Figures 59 and 60). Since the overwhelming majority of the survey lines obtained in the river near Vicksburg were concentrated in Diamond Point Cutoff (approximately RM 425 to 421), this site will be referred to hereafter as the Diamond Point Cutoff survey site. One survey line was extended to a point just upstream from RM 430 during the survey operations conducted in the Mississippi River downstream from Vicksburg. The survey area located between RM 563 and 575 of the Mississippi River will be discussed as the Arkansas City survey sites.

### Physiographic and geologic setting

171. The Diamond Point Cutoff and Arkansas City survey sites are located in the alluvial floodplain of the Lower Mississippi River valley. At each site the river flows through an alluvial environment composed of depositional top-stratum and substratum environments underlain by older Tertiary deposits. The top stratum can be divided into depositional environment types, e.g., natural levee, point bar, backswamp, abandoned course, and abandoned channel deposits. These environments are composed predominantly of fine-grained sediments. The substratum is generally composed of fine sands grading downward into coarser sands and eventually into sands and gravels (Kolb et al. 1978). The Tertiary formation, underlying the substratum at both sites, generally consists of compact lithologic units of various sediment types. At the Arkansas City survey site the Yazoo clay formation underlies the channel substratum. This unit is composed of a massive plastic clay laminated with thin silt and bentonitic clay lenses. At the Diamond Point Cutoff site, the Glendon formation, a dense Tertiary limestone interbedded with fossiliferous, sandy marls either underlies the substratum materials, or is exposed on the bottom of the channel. The Mississippi River channel at



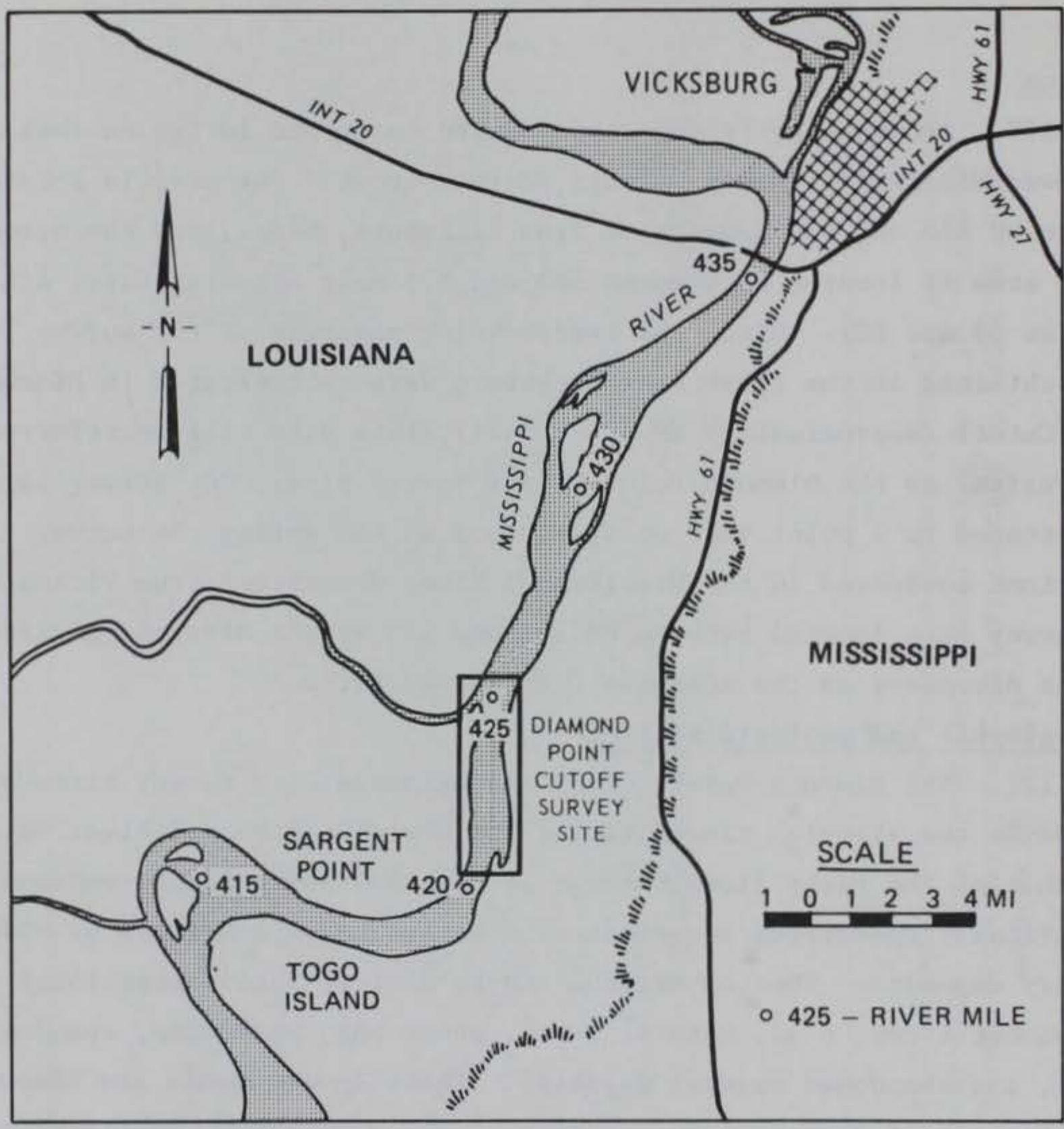

Figure 59. Site vicinity map, Diamond Point Cutoff acoustic survey site, Lower Mississippi River

the Diamond Point Cutoff site lies approximately 3 miles west of the valley wall.

Background of bank erosion problems

172. Although both of the Lower Mississippi River survey sites are characterized by active areas of bank failures and caving, there were additional reasons for selecting these sites for the evaluation of acoustic survey systems. Because the Diamond Point Cutoff reach has been relatively stable over a long period of time, the presence of



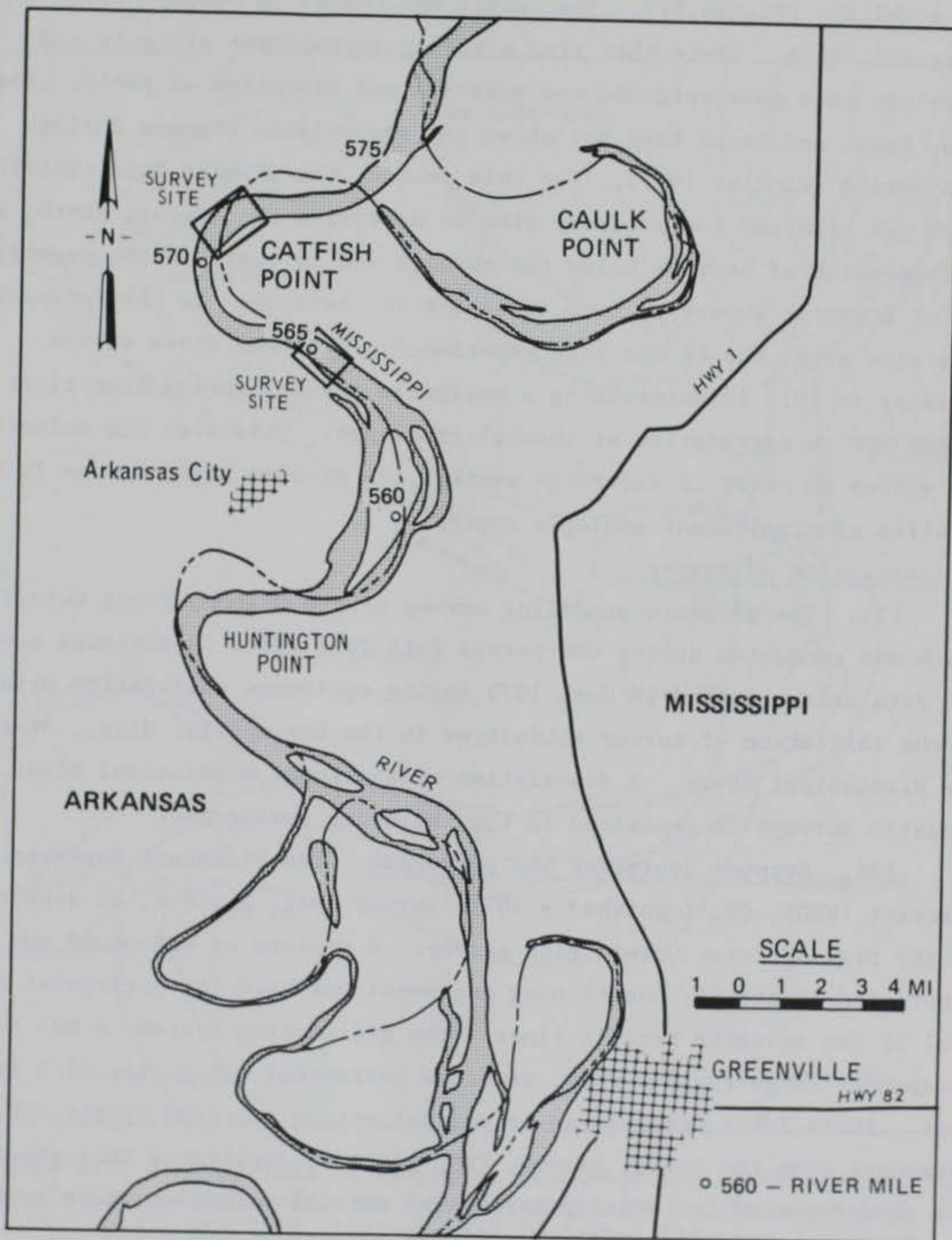

Figure 60. Site vicinity map, Arkansas City acoustic survey sites, Lower Mississippi River



bedrock below the channel from Vicksburg downstream to Diamond Point Cutoff is believed to have had significant effect on channel alignment and stability (Figure 61). The cutoff was opened in January 1933 (Ferguson 1940). Since that time a stable arrangement of pools and crossings have developed and the position and elevation of pools, crossings, bars, and banks have not shown any appreciable changes during this period (Winkley 1977). For this reason, the Diamond Point Cutoff reach was selected for a survey site to determine the extent, depth, and configuration of bedrock below the channel and to evaluate the capability of acoustic survey systems to detect the bedrock. In the Arkansas City site area, the CE has been experiencing problems since severe flooding in 1973 in maintaining a navigable channel during high river stages due to aggradation at channel crossings. This area was selected for survey in order to determine whether the problem might be due to the location of significant geologic controls.

#### Implementation of survey

173. The acoustic profiling survey of the Diamond Point Cutoff reach was conducted during the period 7-15 July 1977. Additional acoustic data were obtained in June 1979 during equipment calibration prior to the initiation of survey activities in the Greenville, Miss., area of the Mississippi River. A description of the Lower Mississippi River acoustic surveys is contained in the following paragraphs.

174. Support equipment and personnel. The Vicksburg Engineer District (VED), CE, furnished a 40-ft survey boat, Logan P, in support of the Diamond Point Cutoff site survey. A mixture of WES-owned and contracted electronic positioning equipment was used for horizontal control of the acoustic profile lines. The positioning system, a Del Norte Trisponder range-range system, provided horizontal accuracies of a few feet. Shore T/R's were placed at control points provided by the VED. Personnel from the Survey Branch, VED, provided assistance throughout the survey period in locating horizontal control points on shore and in providing general guidance for survey line configuration.

175. At the Arkansas City survey site, the VED furnished the survey boat Elmer P, a 42-ft craft. Horizontal positioning was accomplished



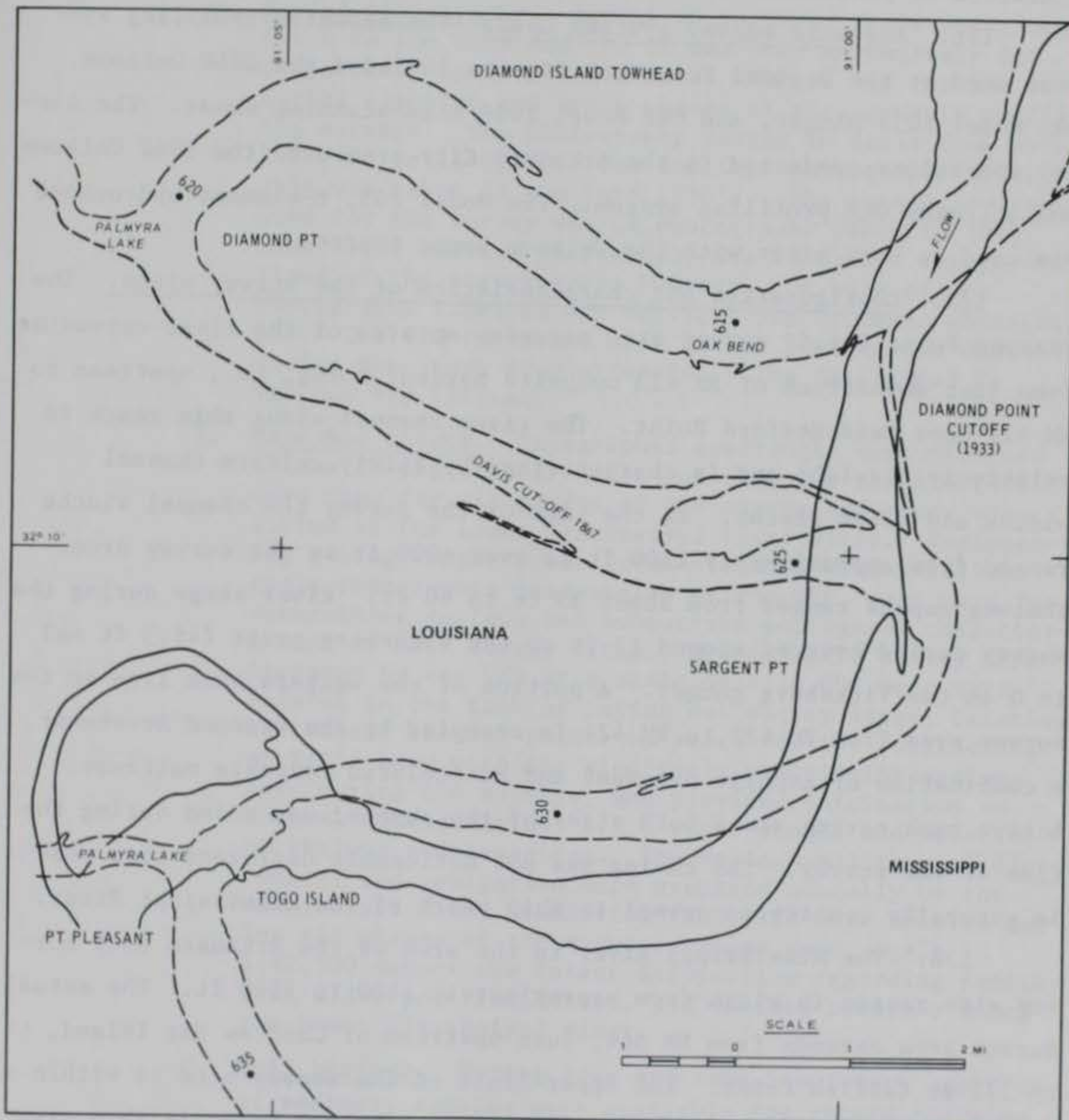

Figure 61. A comparison of alignment of Mississippi River channel in the vicinity of Diamond Point Cutoff survey site in the years 1933 and 1978 (1933 channel is dashed lines)



by visual reference to navigation aids and other landmarks located at various points along the river channel. The survey crew was composed of a mixture of personnel from the WES, VED, and contractor sources.

176. Acoustic survey systems used. The acoustic profiling systems used at the Diamond Point Cutoff site included the EG&G Uniboom, ORE Model 1032 pinger, and ORE Model 1098 side-scanning sonar. The survey operations conducted in the Arkansas City area used the EG&G Uniboom and a 12-kHz ORE profiling system. The Model 265, 8-element hydrophone was used at both sites with the Uniboom sound source.

177. Configuration and characteristics of the survey sites. The Diamond Point Cutoff survey site occupies an area of the river extending from just downstream of RM 423 opposite Sargent Point, La., upstream to RM 427 near Reid-Bedford Point. The river channel along this reach is relatively straight and is characterized by fairly uniform channel widths and water depths. At the time of the survey the channel widths ranged from approximately 2500 ft to over 4000 ft in the survey area. Thalweg depths ranged from about 35 ft to 60 ft. River stage during the survey period hovered around 13 ft on the Vicksburg gauge (46.3 ft msl is 0 on the Vicksburg gauge). A portion of the western bank line in the survey area from RM 422 to RM 424 is occupied by the Diamond Revetment, a combination of asphalt pavement and articulated concrete mattress. Active bank caving along both sides of the channel was noted during the time of the survey. The caving was not noticeably different from what is generally considered normal in this reach of the Mississippi River.

178. The Mississippi River in the area of the Arkansas City survey site ranges in width from approximately 1400 to 3500 ft. The actual survey area extends from RM 564, just upstream of Choctaw Bar Island, to RM 572 at Catfish Point. The upper limit of the survey site is within a large bend of the river (Cypress Bend). The channel banks in this area are extensively revetted. The Catfish Point and Eutaw-Mounds Revetments are located on the east bank and the Cypress Bend Revetment is situated along much of the west bank line. Water depths in the channel thalweg averaged about 60 ft in the survey area.

179. Availability of background and ground truth data. The



following background and ground truth data were available and used during various phases of the acoustic survey conducted at the Diamond Point Cutoff and Arkansas City survey sites.

- a. Aerial photography. Aerial photography flown under contract to the USDA and the CE was used extensively for comparative analysis of channel changes and for use during planning and other phases of the acoustic profiling surveys. The photography ranges in scale from about 1:24,000 to 1:40,000. The earliest photography available was taken in the late 1930's. The latest coverage used for the survey was CE photography taken in 1978. Some color oblique photography was available for portions of the survey area; however, the bulk of the photography examined was vertical panchromatic photography. The VED furnished most of the photography used during the study from extensive files maintained by various VED offices.
- b. Maps and charts. Topographic quadrangle maps produced by the CE and USGS at scales of 1:24,000 and 1:62,500 were used for all phases of the survey and study conducted at the Lower Mississippi River sites. Engineering geology maps, produced on standard USGS 1:62,500-scale topographic quadrangles by the WES, were used for determining surface and subsurface geological characteristics at both survey sites. Hydrographic survey maps prepared by the VED at a scale of 1:10,000 were very helpful in the task of laying out survey lines, locating horizontal control points on shore for the positioning of T/R's used with the electronic positioning systems used during the surveys, and provided information on channel configuration, i.e., water depths and location of thalweg and crossings. The various editions of flood-control and navigation maps prepared annually by the Mississippi River Commission (MRC), CE were helpful during all phases of the survey. These maps, scale 1:62,500 depict the latest information regarding navigation aids, port facilities, and thalweg position along the Lower Mississippi River.
- c. Soil borings. Boring logs and some laboratory analyses of sediment samples were available for record correlation and geological control of the acoustic profiling surveys at the Diamond Point Cutoff and Arkansas City survey sites. These borings, drilled by the VED along the banks of the channel during preconstruction studies for revetments and other structures, provided the most significant sources of "ground truth" data available for correlation with the acoustic profile records. Although



the preponderance of these borings were obtained prior to the acoustic surveys (some dating back to the 1930's), many of the boring logs were very helpful in substantiating reflection horizons contained in the acoustic records. Many borings, such as those drilled before and after the construction of the Diamond Point Cutoff, were extended to the top of the underlying Tertiary formation. These borings were particularly valuable in correlating the top of bedrock at the Diamond Point Cutoff survey site, and also the top of Tertiary formations at the Arkansas City site. In most instances, the boring information was projected laterally to the area of the acoustic profile for correlative purposes. However, only those borings which were drilled to sufficient depths below the position marking the deepest portion of the channel could be used in this manner.

- d. Miscellaneous. There were many CE documents available that provided helpful information on the history and physical characteristics of the Diamond Point Cutoff and Arkansas City survey areas.

180. Survey procedures. At the Diamond Point Cutoff survey site, a combination of the WES EG&G Uniboom, ORE pinger, and ORE side-scanning sonar acoustic survey systems were used. The Uniboom and pinger were operated simultaneously throughout the survey period except for the portion of the survey where side-scanning sonar was used. During acquisition of side-scanning sonar data, the ORE pinger and side-scanning system were operated only and the data from these systems were recorded simultaneously on a single graphic recorder. The Diamond Point survey area was profiled on a rough grid basis (Figure 62). Essentially parallel profile lines were acquired along the axis of the channel from one side of the channel to the other. In addition, cross-sectional profiles were run at approximately 2000-ft intervals to provide tie-ins to the longitudinal profile lines. Three remote T/R's of the Del Norte Trisponder positioning system, utilized for control of the profile lines, were stationed on shore to provide adequate coverage of the entire survey area. Position fix marks approximately one minute in time apart were obtained along the acoustic profile lines. This time interval used resulted in position fixes roughly 300 to 400 ft apart. The variation in distance between fixes is due primarily to differences in boat speeds and current velocities encountered within the survey area.



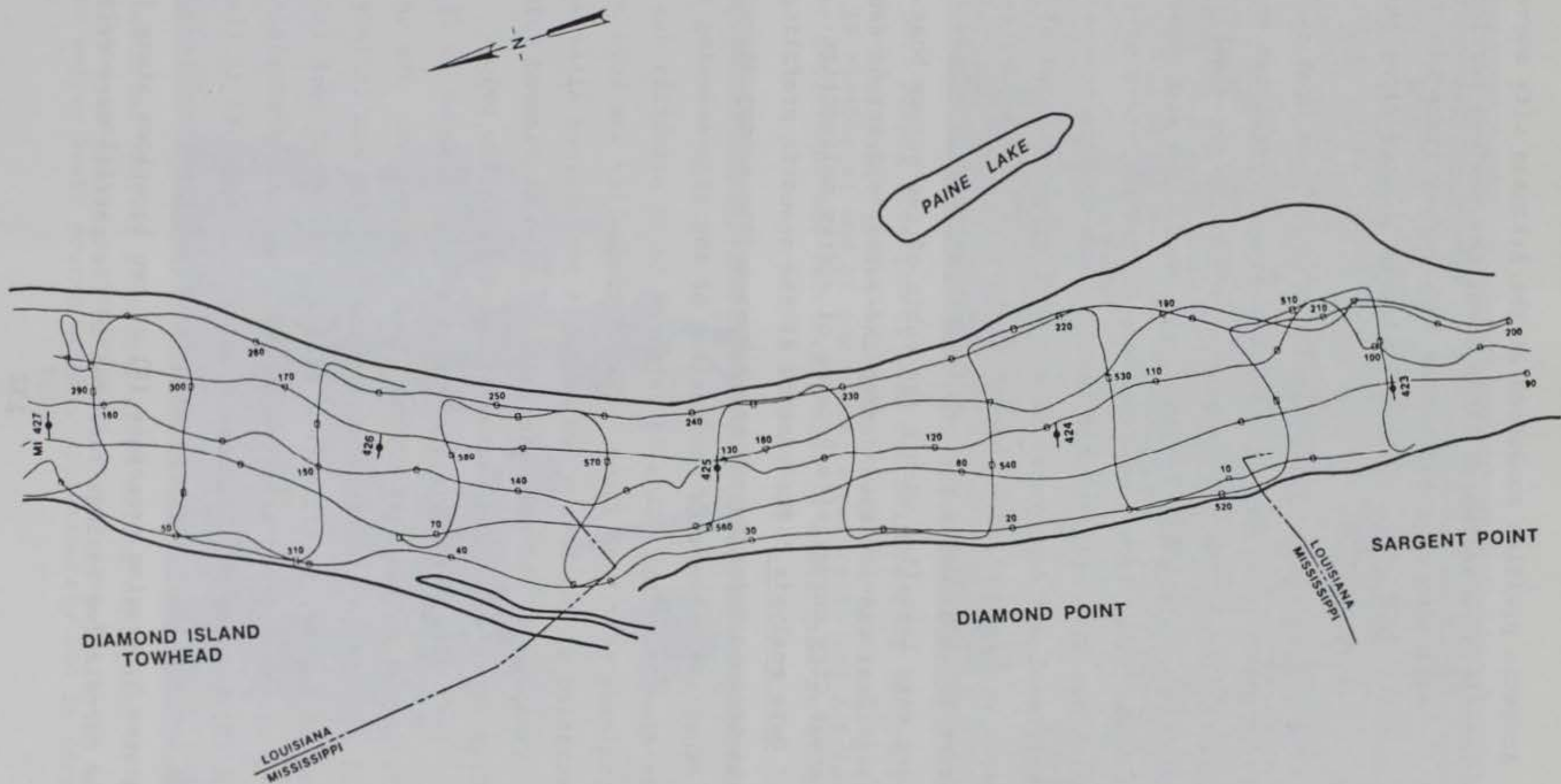

Figure 62. Acoustic survey line configuration, Diamond Point Cutoff acoustic survey site



181. Acoustic profiles conducted at the Arkansas City survey site consisted primarily of a series of lines along the thalweg portions of the channel. Positioning of the Arkansas City survey lines was accomplished by visual reference to various landmarks located along the channel bank lines.

182. The towing configuration of the EG&G Uniboom used at both survey sites is shown in Figure 63. The ORE pinger system was attached to the starboard side of the survey boat in the "over-the-side" configuration about midway along the length of the boat. The side-scanning sonar towfish was towed from an A-frame mounted on the stern of the survey boat which was also utilized for handling the Uniboom source (Figure 64). Retrieval and deployment of the towfish and control of the fish tow depth was accomplished through the use of a remote-controlled winch. Figure 65 illustrates part of the onboard survey system components as they were installed within the cabin of the survey boat. The side-scanning sonar was not used during the survey operations conducted at the Arkansas City survey site because of system malfunction.

183. Data analysis. The results of the acoustic profiling operations at the Diamond Point Cutoff and Arkansas City survey sites were generally excellent. However, the quality of the side-scanning sonar records was disappointing. This is believed to be primarily due to severe turbulence near bank lines. CSRP data quality was good and adequate penetration of the bottom sediments at both survey sites was achieved. Examples of the acoustic data acquired at Diamond Point and Arkansas City sites and a discussion of the data follow below.

184. CSRP data. The limestone rock formation shown in Figure 66 is Tertiary in age and is part of the Glendon formation. The unit is composed of stratified limestone of varying hardness and is interbedded with layers of softer, fossiliferous marls. The top of rock (A) is veneered by unconsolidated alluvium deposits composed predominantly of silty sand (H) ranging in thickness from about 2 to 25 ft in the area covered by the profile. The uppermost layers of limestone and marl have been truncated by erosion processes (F) at two locations along the profile. The correlative borings included in the profile were drilled





Figure 63. Towing arrangement used for Uniboom CSRP system at Diamond Point Cutoff and Arkansas City survey sites, Mississippi River (Sound source is visible at end of tow cable; steel cable and A-frame are used for deployment and retrieval; view is downstream at Diamond Point Cutoff survey area.)



Figure 64. Survey personnel shown during deployment of the Uniboom profiling system's sound source from the stern of the survey boat; source weight, approximately 200 lb (from VED)



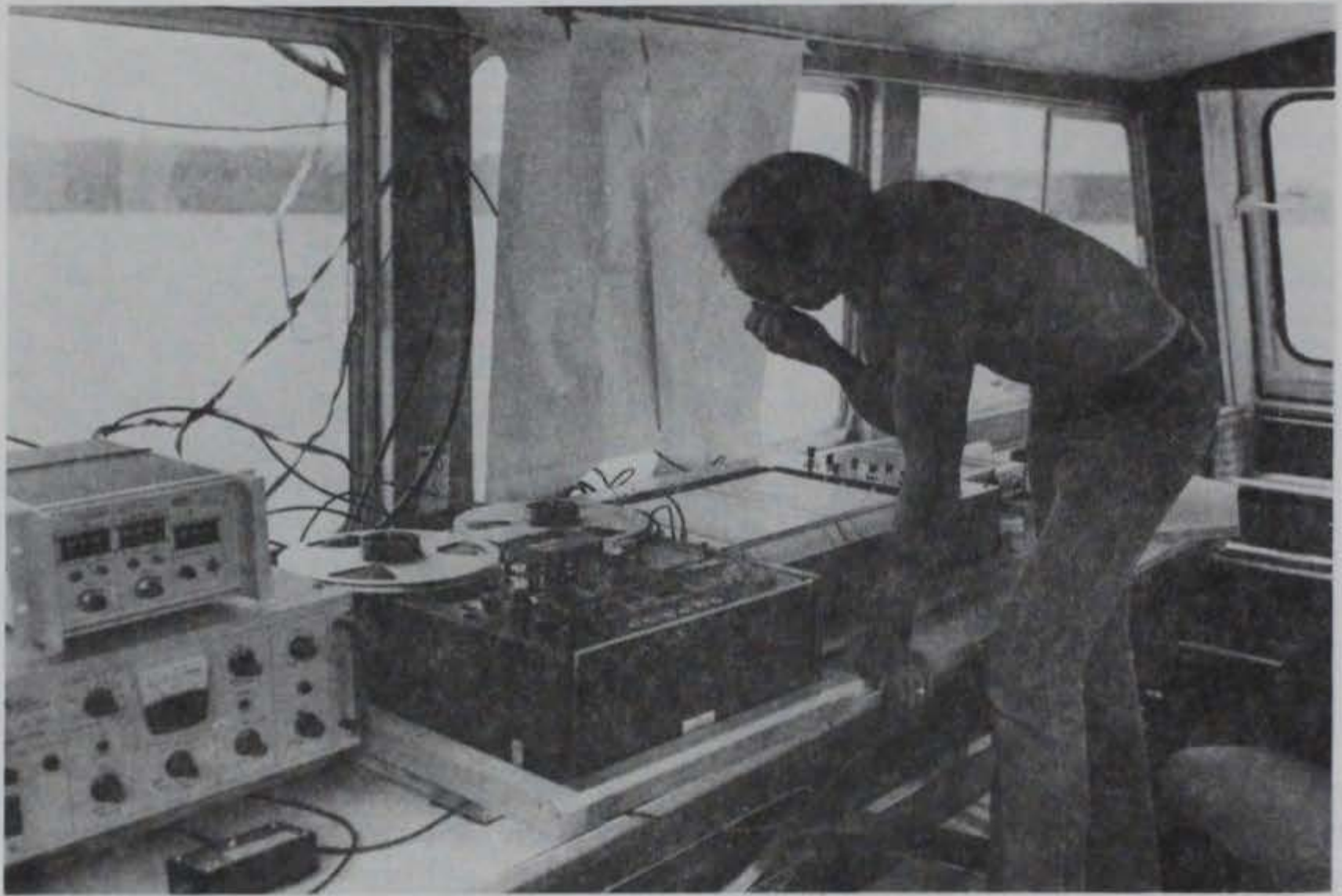

Figure 65. Onboard acoustic survey system components as used during acoustic survey operations at sites on Lower Mississippi River; programmer, transceiver, magnetic tape recorder, and seismic recorder components shown (left to right)

prior to the construction of the Diamond Point Cutoff and show excellent correlation with the acoustic profile. The rock surface at (G) is almost exposed, veneered by no more than a couple of feet of sediment. The water surface is at (C), the direct arrival is at (D), and multiples of the channel bottom and rock formation are at (E).

185. Figure 67 is a pinger record of the Glendon formation limestone in Diamond Point Cutoff. The top of rock (F) is located at a relatively constant elevation along the length of the profile. The rock surface has been truncated by erosion at (G). Unconsolidated alluvial deposits (I) composed of silt and sand cover the rock formation. An unknown feature located approximately midway between the channel bottom and the top of rock is located at (E). The water surface is at (A), and the channel bottom at (B). The time-varying gain (TVG) marks (C) result from adjustments of the TVG. Position fix marks are at (D) and



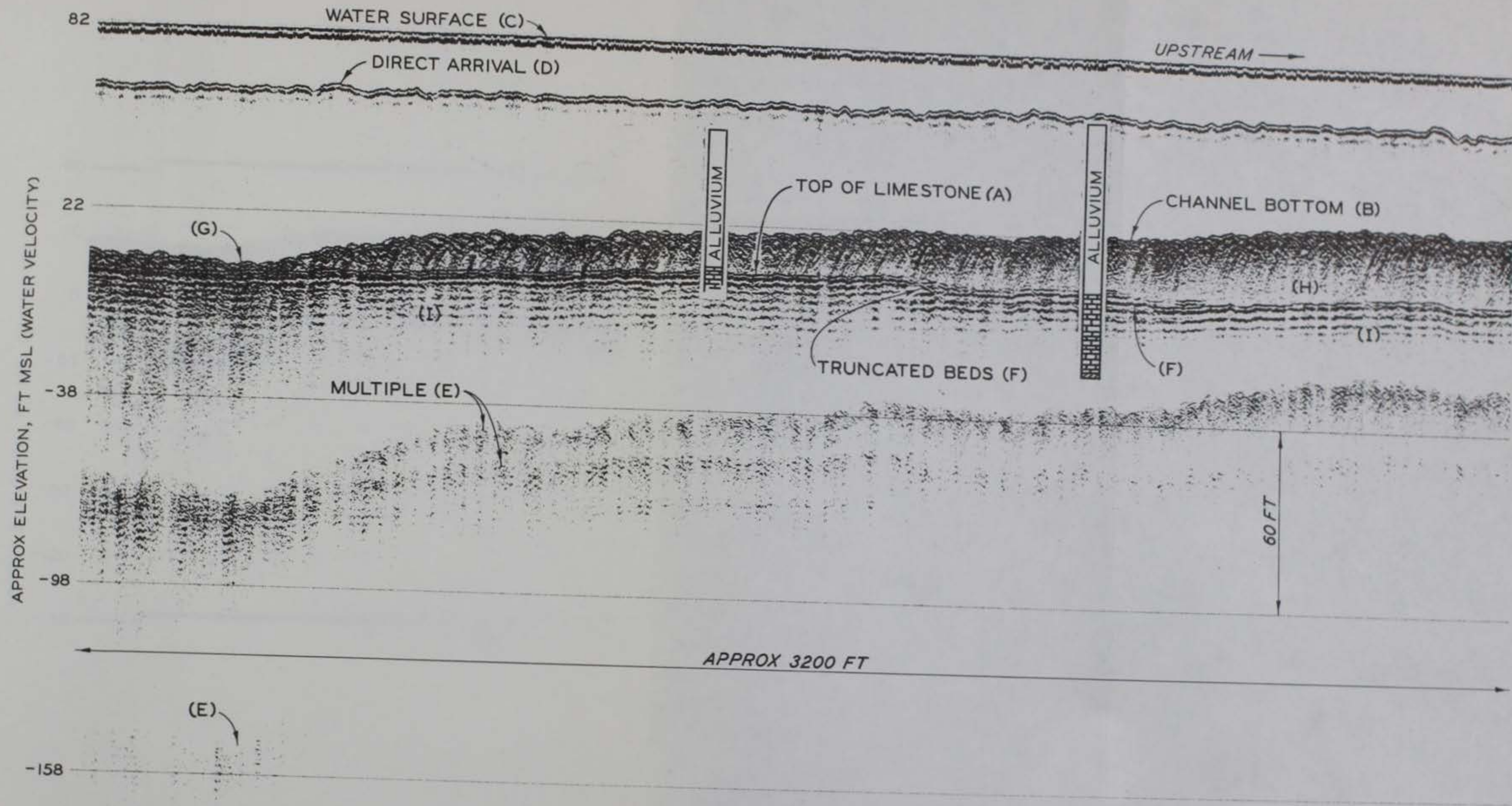

Figure 66. Boomer record, Diamond Point Cutoff, Lower Mississippi River



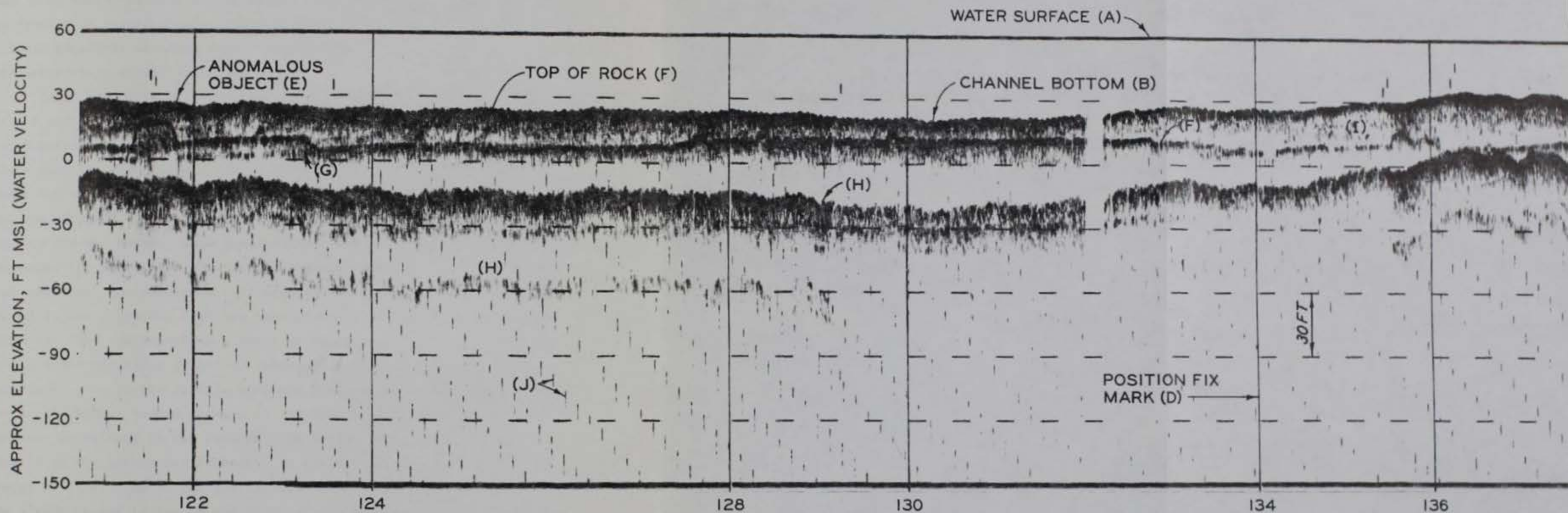
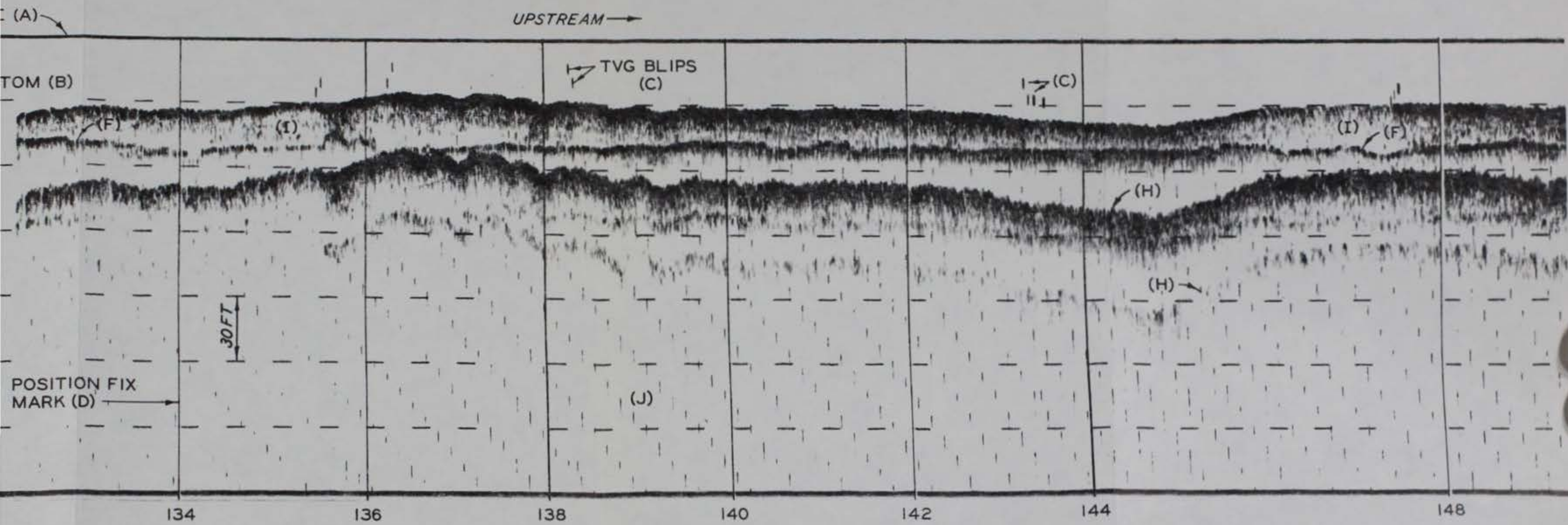

Figure 67. Pinger record at Diamond Point Cutoff, Mississippi River, showing Glendon limestone formation





off, Mississippi River, showing Glendon limestone formation at various depths below present channel bottom



multiples of the channel bottom and top of rock are at (H). The pattern of evenly spaced, vertical marks at (J) is an interference pattern originating from a boomer CSRP system that was used concurrently with the pinger CSRP system. The pinger record (Figure 67) is characteristically made up of various tones of reflection intensity as opposed to individual lines characteristic of the boomer record shown in Figure 66. This difference in record characteristics is due primarily to the type of graphic recorders utilized rather than differences in the operational characteristics of the sound sources.

186. The profile (Figure 68), a split-trace recording showing boomer and 12-kHz pinger data, displays a large hole (A) scoured by water turbulence on the downstream side of a stone-filled dike (B). The scour pool is approximately 100 ft deep at this river stage. Two anomalies are visible in the vicinity of the scour pool, one buried (C) and one situated on the bottom of the hole (D). The identities of these objects are not known. Some possibilities are: (a) detached bedrock segments, (b) stone from the dike, (c) sunken vessels, or (d) other man-made objects. The subbottom reflector (I) is thought to be coarse material, i.e., gravel, that has been eroded from the scouring action below the dike and deposited a short distance downstream of the scour hole. Finer materials deposited subsequently have buried the coarser materials. The 12-kHz profile does not display bottom penetration similar to the boomer record because of its higher frequency characteristics. However, as evident in the records, the bottom characteristics and objects on the bottom are presented in greater detail compared to the boomer profile. The slight discrepancy in vertical scale present in the 12-kHz record is due to the depth of the 12-kHz transducer below the water surface (approximately 4 ft). The water surface is at (E), the direct arrival at (F), the channel bottom at (G), and multiples at (H). The horizontal scale is 1 in. = approximately 200 ft.

187. Another profile at Racetrack Dikes which demonstrates the cyclic nature of stream regimen is shown in Figure 69. The profile shows a large scour hole being filled with sediment (B). The older, or original scour hole bottom is at (A), a strong acoustic reflector



located below the recent sedimentation. The hummocky features at (I) are probably remains of material excavated by scouring processes from the original scour hole. The reflector (H), faintly visible below the present bottom, may be limestone bedrock of the Glendon formation. The rock would, of course, prevent further degradation of the scour hole bottom below the elevation of the rock surface. The stone-filled training dike is at (D), the channel bottom is (C), and multiples at (G). The hyperbola signatures at the dike and along the channel bottom upstream of the dike are point source reflections from sand dunes or from pieces of stone dike material. The horizontal scale of the record is 1 in. = approximately 200 ft.

188. The boomer profile (Figure 70) shows the top of the Tertiary formation (A) which is composed of the Yazoo clay formation in this area. The reflection horizon (B) above the Yazoo clay formation is located in Holocene alluvium and is thought to represent the break between fine-grained top-stratum alluvium and coarse-grained substratum alluvium below. The contact between the Tertiary deposits and Holocene deposits is well marked as evidenced by the consistent acoustic reflection along the unconformity separating the two geologic formations at (A). The Tertiary bedding (C) is truncated along the unconformity (A). Small flexures in the bedding are apparent at (D). The marker bed (E) within the Tertiary formation is visible as a reflection ranging from 75 to 90 ft in depth below the channel bottom (F). The water surface is at (G), the direct arrival at (H), and multiple reflections at (J). The boring log is projected into the profile line from a position on the bank. Sediments logged above the top of the Tertiary are bank materials. Unified Soil Classification System (USCS) symbols are used in the boring logs. Source of the boring logs is VED. The horizontal scale of the profile is 1 in. = approximately 200 ft.

189. Figure 71 is a boomer record obtained near Arkansas City, Ark. The profile shows the top of the Tertiary formation (A), a marker bed (B) within the Tertiary, and an irregular reflection (C) located above the Tertiary surface. The reflection (C) is believed to represent the top of a gravel deposit identified on boring logs in the area as GP or



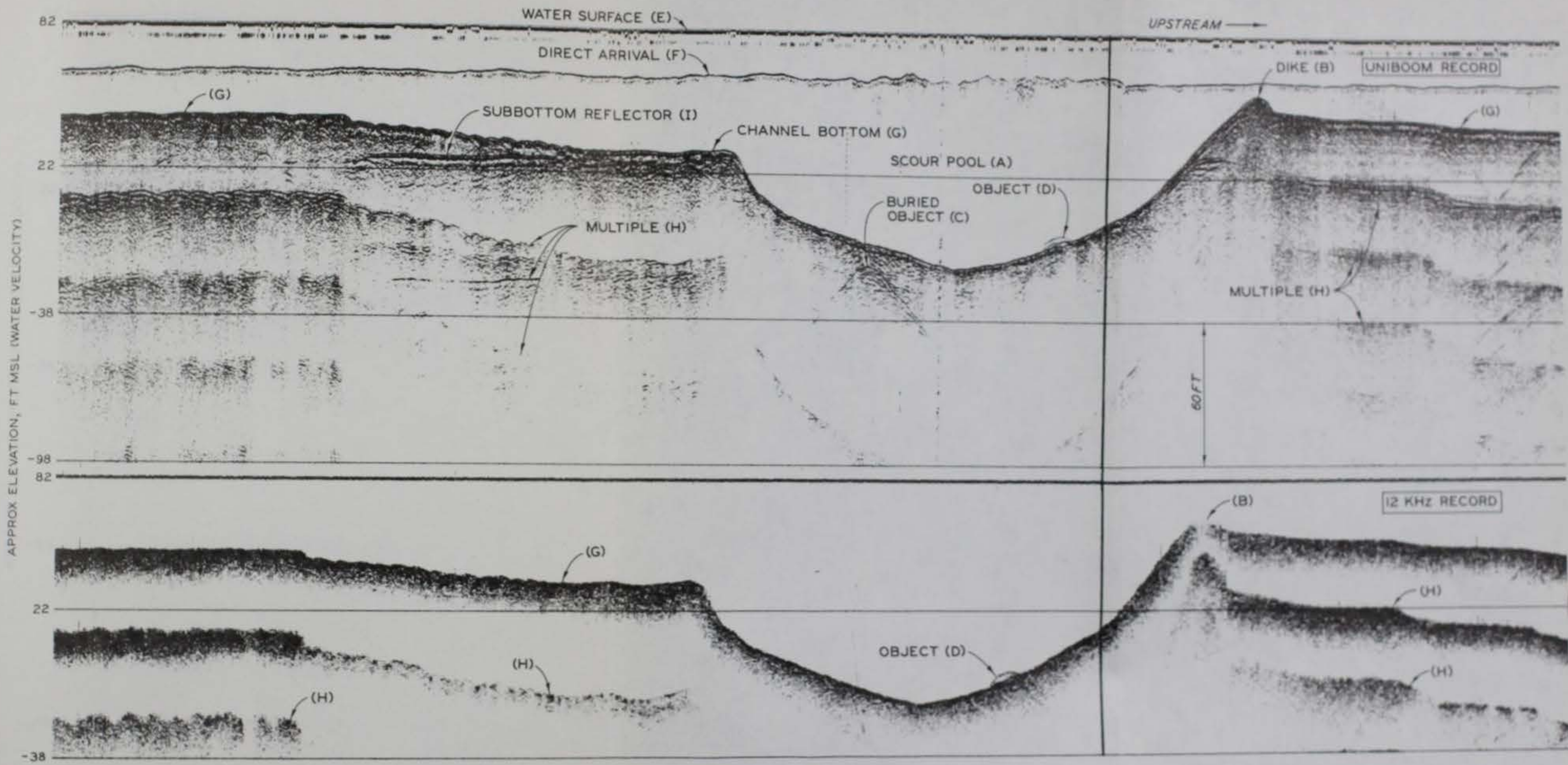

Figure 68. Boomer and 12-kHz pinger profile record, Racetrack Dikes, near Vicksburg, Miss., Lower Mississippi River







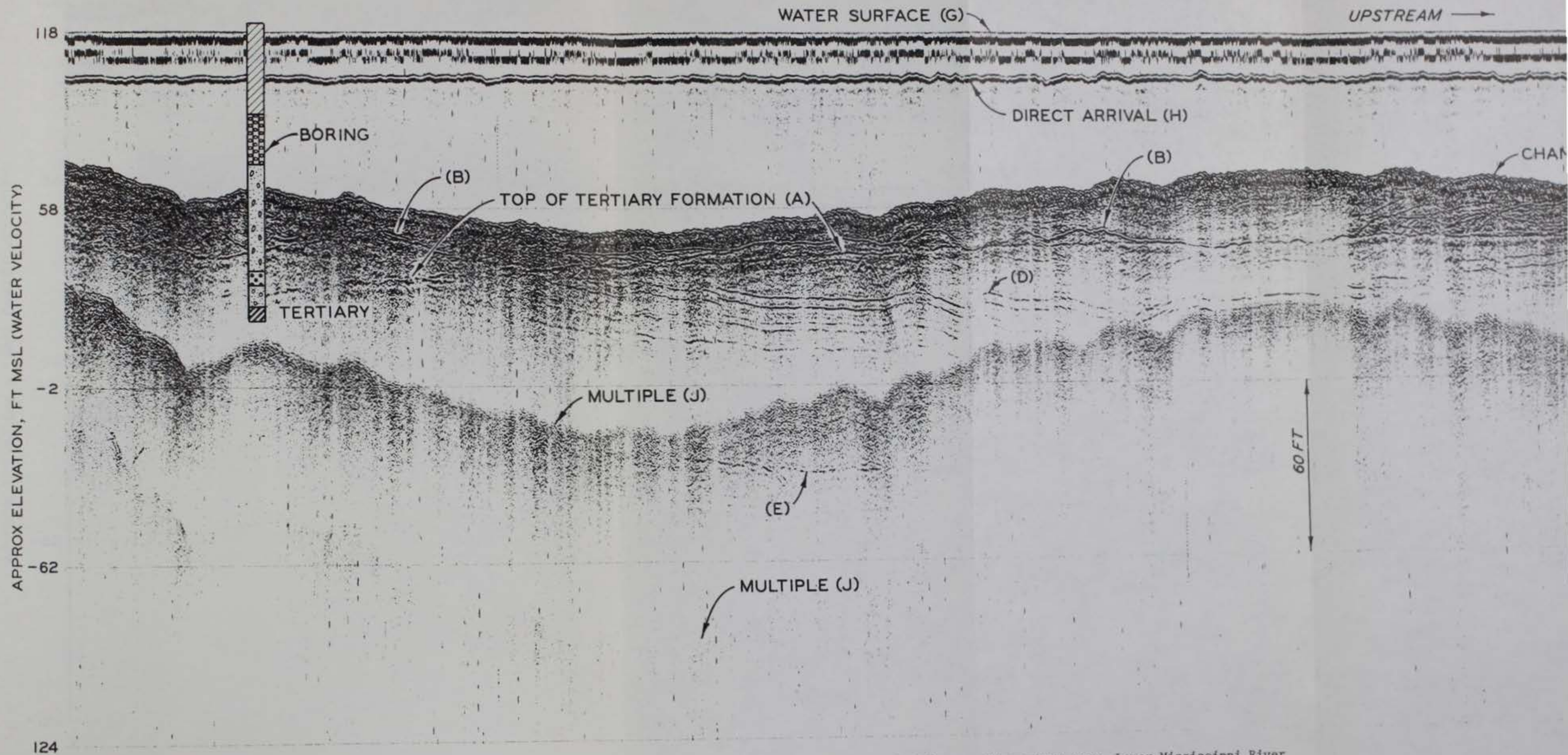

Figure 70. Boomer record, Arkansas City survey area, Lower Mississippi River



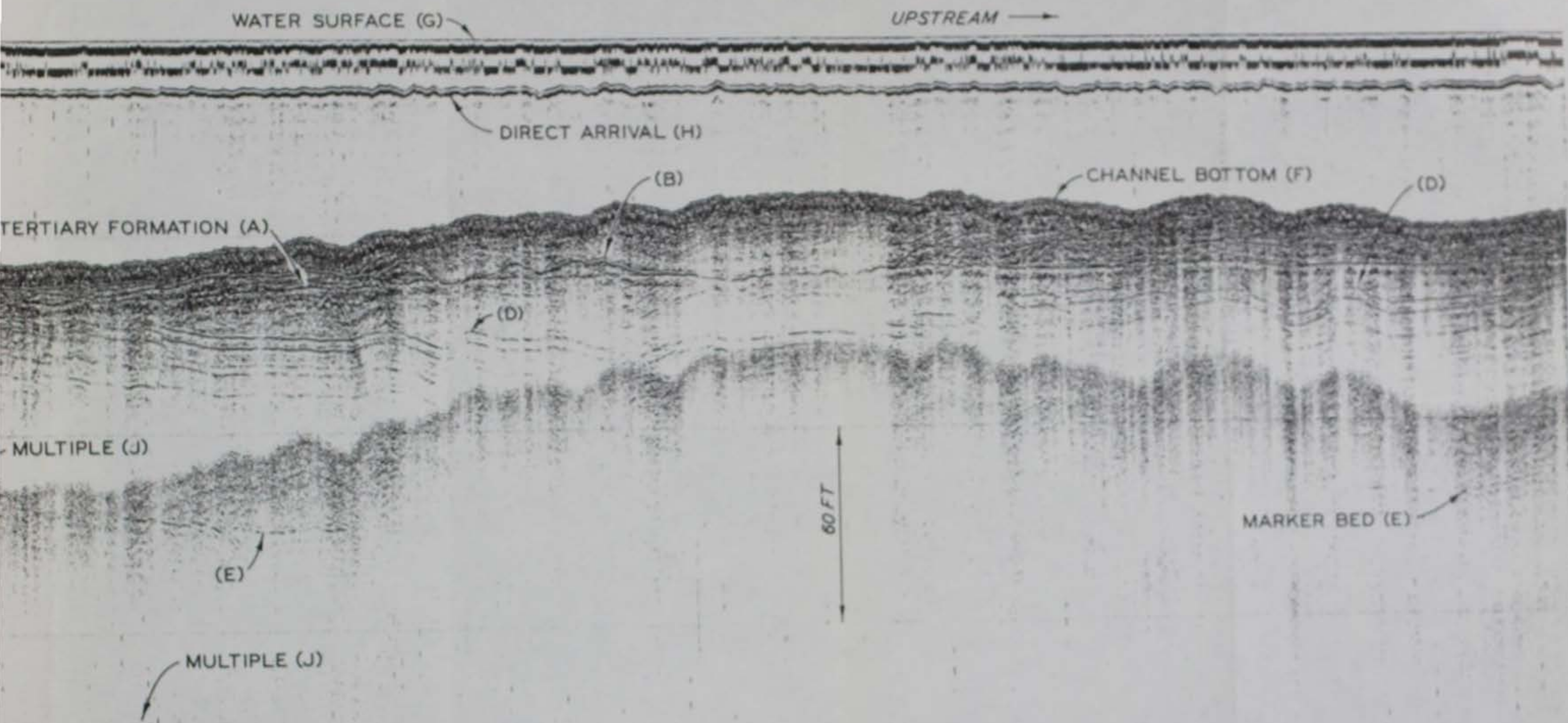

Figure 70. Boomer record, Arkansas City survey area, Lower Mississippi River



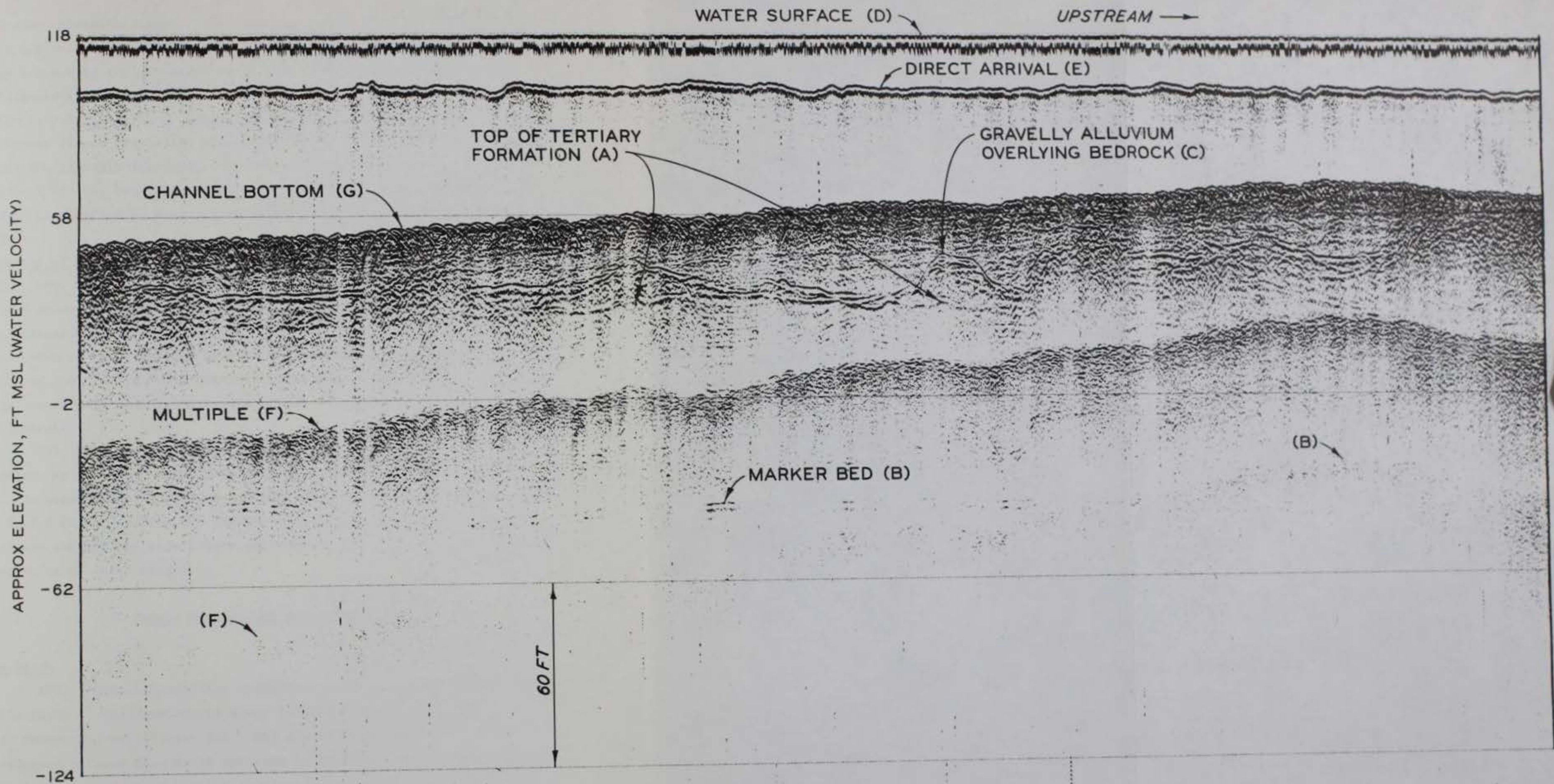

Figure 71. Boomer record, Arkansas City survey area, Lower Mississippi River



GW (USCS classification). The irregular nature of the surface of the (C) reflection may indicate that the deposit has been subjected to variable scour by the river and backfilled with more recent alluviation to thicknesses as great as 30 ft. Note that the top of the Tertiary formation is relatively flat, suggesting that the materials composing the Tertiary (Yazoo clay?) are more resistant to scour and erosion processes than the gravelly deposits. The water surface is at (D), the direct arrival at (E), multiple reflections at (F), and the channel bottom at (G). The horizontal scale of the profile is 1 in. = approximately 200 ft.

#### Results of survey

190. The application of CSRP techniques at the Lower Mississippi River survey sites demonstrated their value in locating, identifying, and assessing geological controls in and below the fluvial channel. The detection of the limestone bedrock and measurement of top of rock elevation at the Diamond Point Cutoff site is significant because estimates can now be made concerning future trends in depth of scour and channel alignment.

191. The identification of the Yazoo clay formation with CSRP systems at Arkansas City survey site is significant because of the formation's erosion-resistance characteristics. The Yazoo clay appears to be a factor in controlling the maximum depth of the Mississippi River channel and thereby may affect both aggradation and degradation processes, depending on water stages.

### Middle Mississippi River Survey Area

#### Location

192. Acoustic profiling operations were conducted within an 83-mile reach of the Mississippi River located between Cairo, Ill., and St. Genevieve, Mo. (Figure 72). The actual reach in which surveying was performed extends from RM 36 upstream to RM 118.6 (miles above Cairo). RM 36 is located about 4 miles downstream of Commerce, Mo. RM 118.6 is



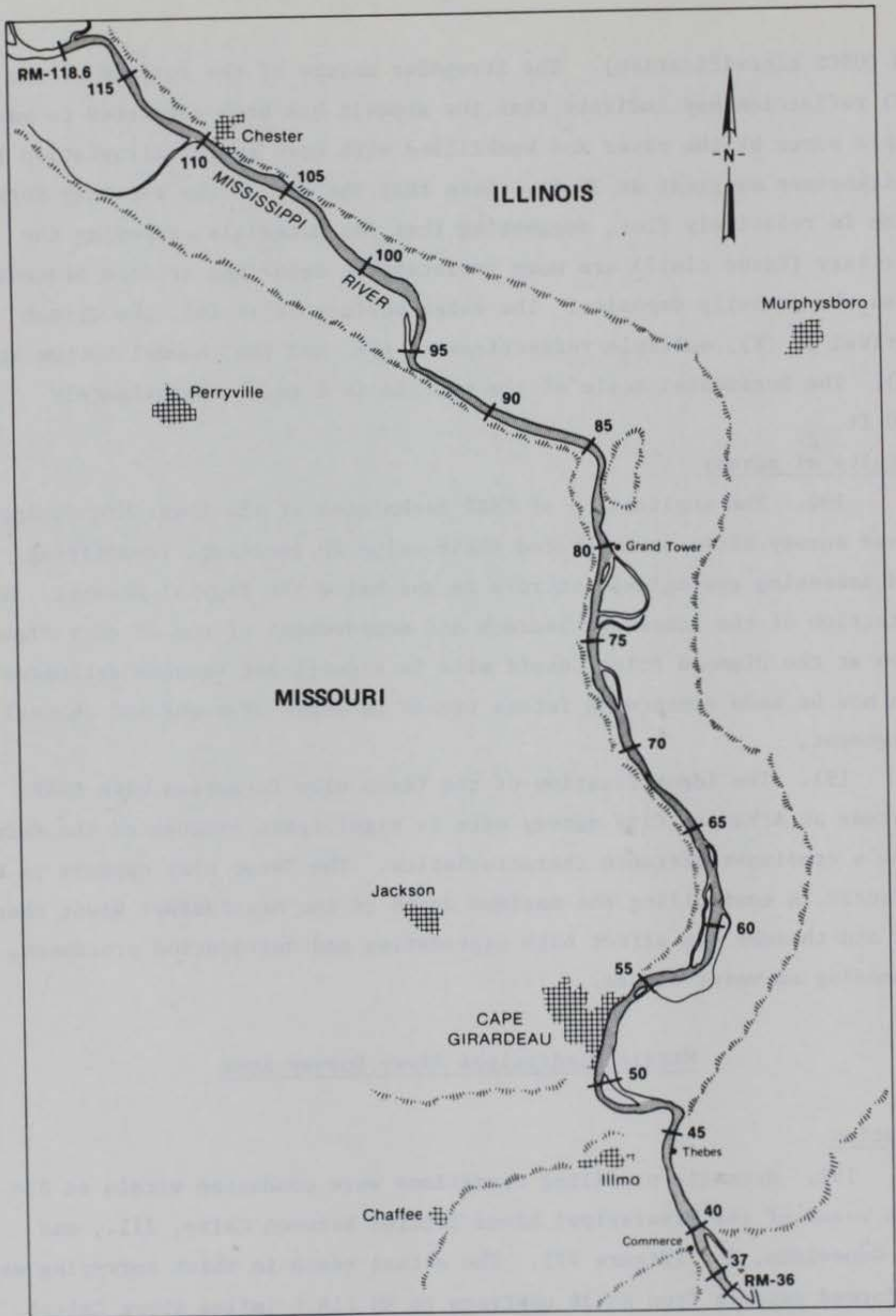

Figure 72. Location map of Middle Mississippi River acoustic profiling survey area



located approximately one-half mile upstream of the present mouth of the Kaskaskia River.

#### Physiographic and geologic setting

193. The survey area is located in the Middle Mississippi River alluvial valley which extends roughly from the mouth of the Missouri River to Cairo, Ill. From the upper limits of the survey area to Thebes, Ill., the river occupies a narrow, bedrock-controlled alluvial valley which ranges from about 4 to 6 miles in width. Near Thebes, the river enters a narrower, rock-walled valley about 6 miles long which bisects an area of uplands called the Benton Hills in Missouri (known in some quarters as the Commerce Hills) and the Shawnee Hills in Illinois. The Mississippi leaves Thebes Gap at Commerce and follows a meandering path through a broad, flat floodplain to its juncture with the Ohio River at Cairo.

194. From the northern limits of the survey area near the mouth of the Kaskaskia River to a point about 5 miles downstream from Chester, Ill., the Mississippi River hugs the eastern valley wall. At this point it swings gradually across the valley and intersects the western valley wall at Red Rock Landing, Mo. From Red Rock Landing to Cape Girardeau, the channel remains against the western valley wall, deviating from its position only slightly in a few places. The valley floodplain is of low relief with natural features probably not exceeding 10 ft in relief. However, two notable features, Fountain Bluff and Tower Rock, located in approximately the middle of the survey area, break the generally featureless floor of the valley. Fountain Bluff (Figure 73), an erosional remnant that rises over 400 ft above the valley floor, is separated from the rugged hills forming the western valley wall by the channel of the Mississippi. Tower Rock (Figure 74), a well-known geologic feature located in the channel of the Mississippi River across from the town of Grand Tower, Ill., is an erosional remnant composed of alternating chert and silty limestone rock formations.

195. The surface of the Mississippi River alluvial floodplain in which the survey area is located is characterized by similar environments of deposition as present in the Lower Mississippi River valley.



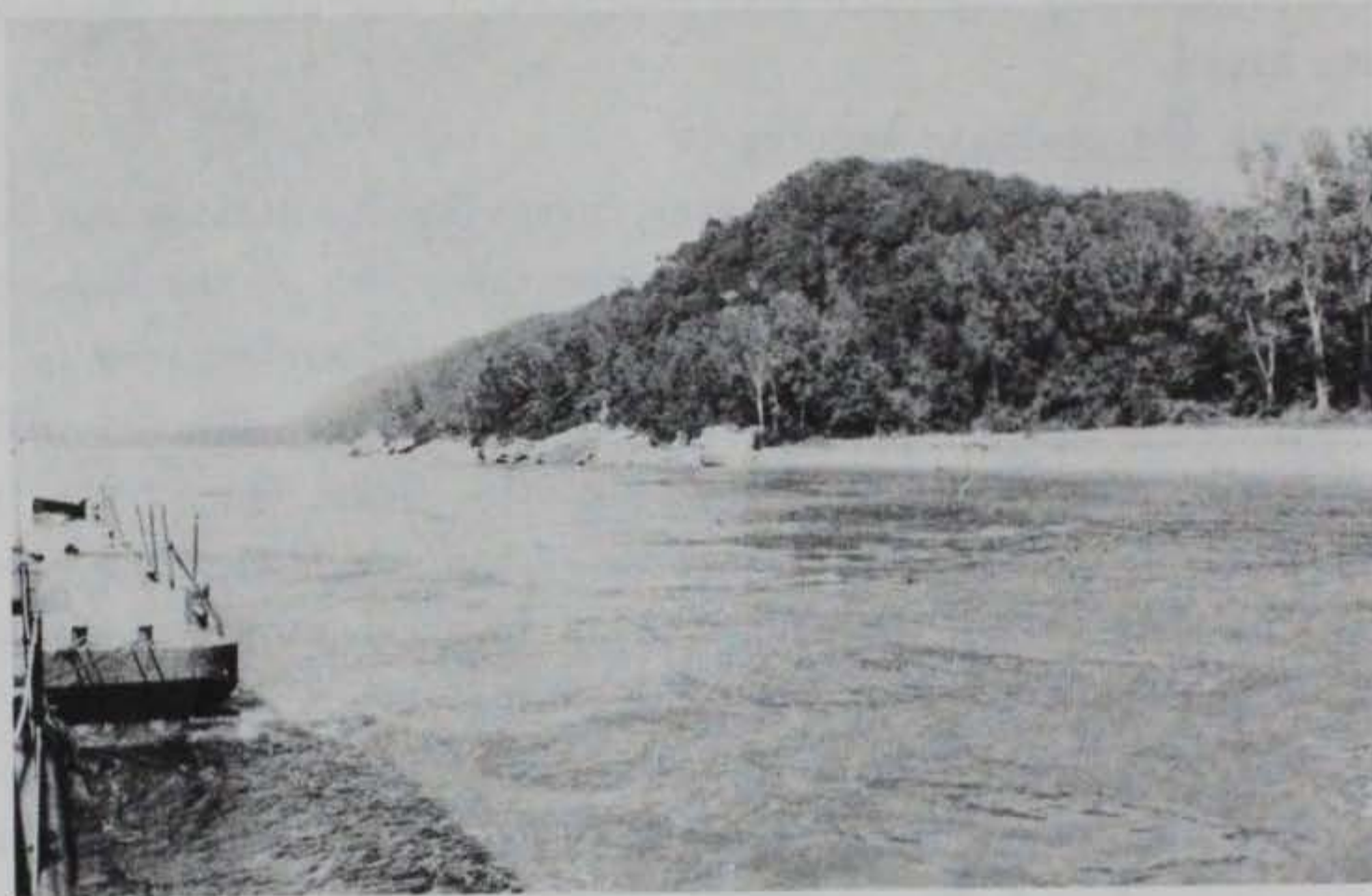

Figure 73. Fountain Bluff, a rugged, heavily forested erosional remnant rising to more than 400 ft above the alluvial floodplain near the middle of the survey area

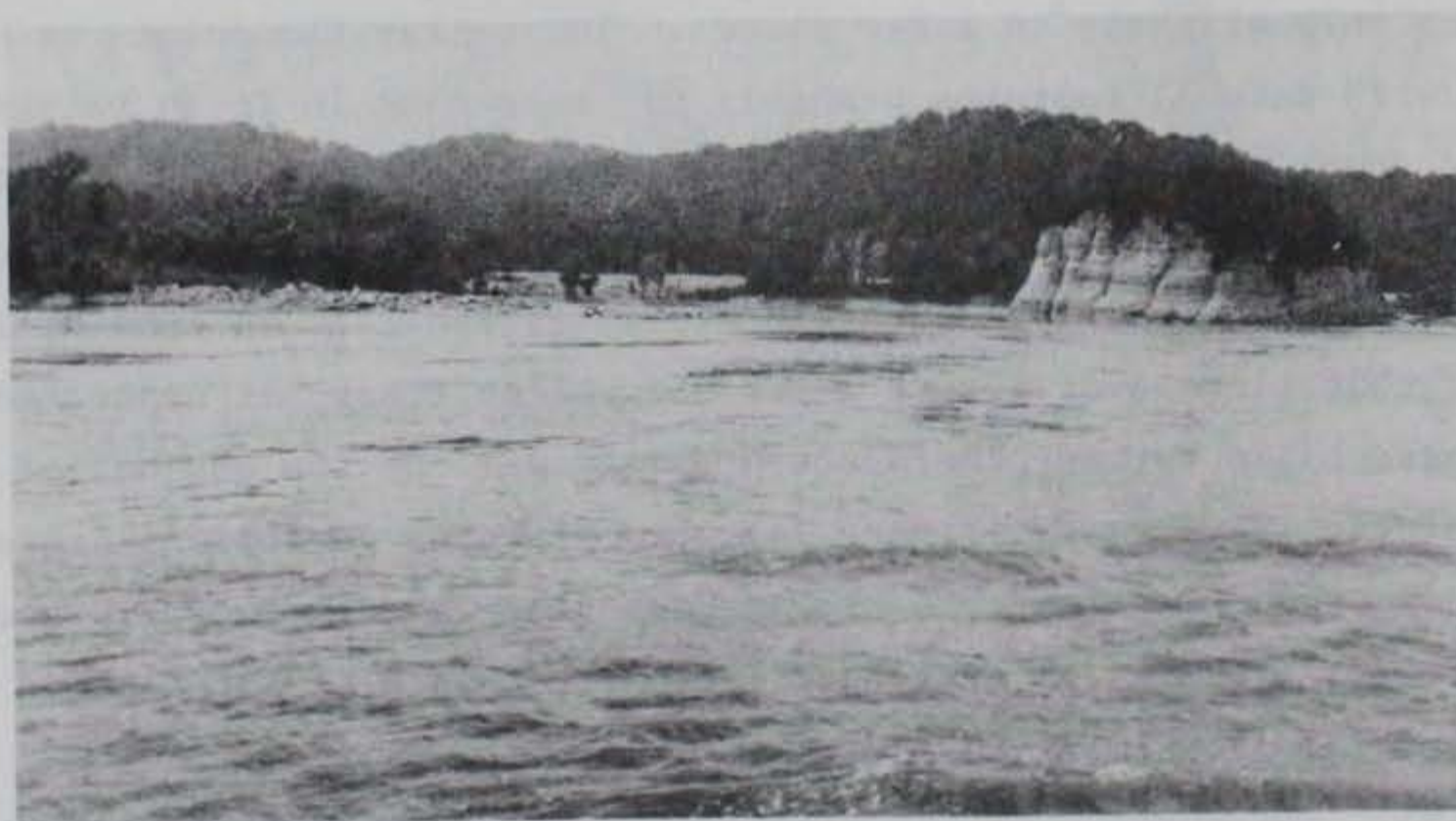

Figure 74. Tower Rock, an erosional remnant composed of Devonian rock located in the channel of the Mississippi River at Grand Tower, Ill.



Abandoned channel, point bar, natural levee, and backswamp environments are the most common alluvial landforms located in the valley. These depositional environments are composed predominantly of silts and sandy and silty clays which grade into coarse sands and gravels that have been deposited during the Holocene. Underlying the Holocene are varying thicknesses of sands and gravels deposited as a result of outwash from glaciers during the Pleistocene. These Pleistocene outwash materials generally rest on bedrock throughout the valley. Information concerning the depth of bedrock below the valley floor in the survey area is somewhat limited. A boring drilled during foundation investigations for the Kaskaskia Locks and Dam in the extreme northern part of the survey area revealed top of rock (limestone) as much as 144 ft (elevation 230.7 ft msl) below the valley floor near the present course of the Mississippi River (U. S. Army Engineer District, St. Louis 1964). Other sources indicate a top of rock elevation as low as 159 ft msl in the Cape Girardeau area (Munger et al. 1976). Initial interpretation of acoustic profiling records obtained in the survey area indicate that top of rock is at shallower depths in parts of the study area than available published literature indicates. Top of rock as interpreted from the acoustic profile data was 50 ft or less (outcropping at the channel bottom in several places) at numerous locations within the survey area. However, some of these locations are close to the valley walls where bedrock would be expected to be at relatively shallow depths.

#### Implementation of survey

196. The Middle Mississippi River acoustic profiling survey was conducted during the period 10-22 August 1979. The 83-mile reach of the river was surveyed working out of Cape Girardeau, Mo., and Chester, Ill. A general description of the acoustic survey is contained in the paragraphs below.

197. Support equipment and personnel. The towboat, MV GASTON G. CRANE, and crew were furnished by the St. Louis District (SLD), CE in support of the survey. A 90-ft barge, lashed to the bow of the boat and containing hoisting equipment, was used for storage and towing of certain components of the acoustic survey systems (Figure 75). Personnel





Figure 75. Barge and towboat configuration used as survey platform in support of Middle Mississippi River acoustic profiling survey, Cape Girardeau highway bridge in the background

from the Survey Branch, SLD, provided assistance in positioning of the survey lines throughout the survey area.

198. Acoustic survey systems used. The EG&G Uniboom CSR system, and the EG&G Mark 1B side-scanning sonar system were used for the acquisition of the acoustic profiling data during the conduct of the survey. The EG&G Model 265 hydrophone was used as the receiving component for the Uniboom system.

199. Configuration and characteristics of the survey area. As previously mentioned, the survey area encompasses an area of the Middle Mississippi River approximately 83 miles in length. The Mississippi River in this area is generally an open navigation channel resulting from heavy modification by man. Figures 76 and 77 are representative views of the channel within the survey area. The channel ranges in width from slightly less than 1000 ft to about 3500 ft. The average width of the channel in the survey area is about 2800 ft. The channel is characterized by large numbers of stone training dikes (Figure 78)





a. View upstream of railway bridge at Thebes, Mo. (Small, mounded feature downstream of bridge in the center of photograph is Counterfeit Rock, an artificially constructed navigation aid.)

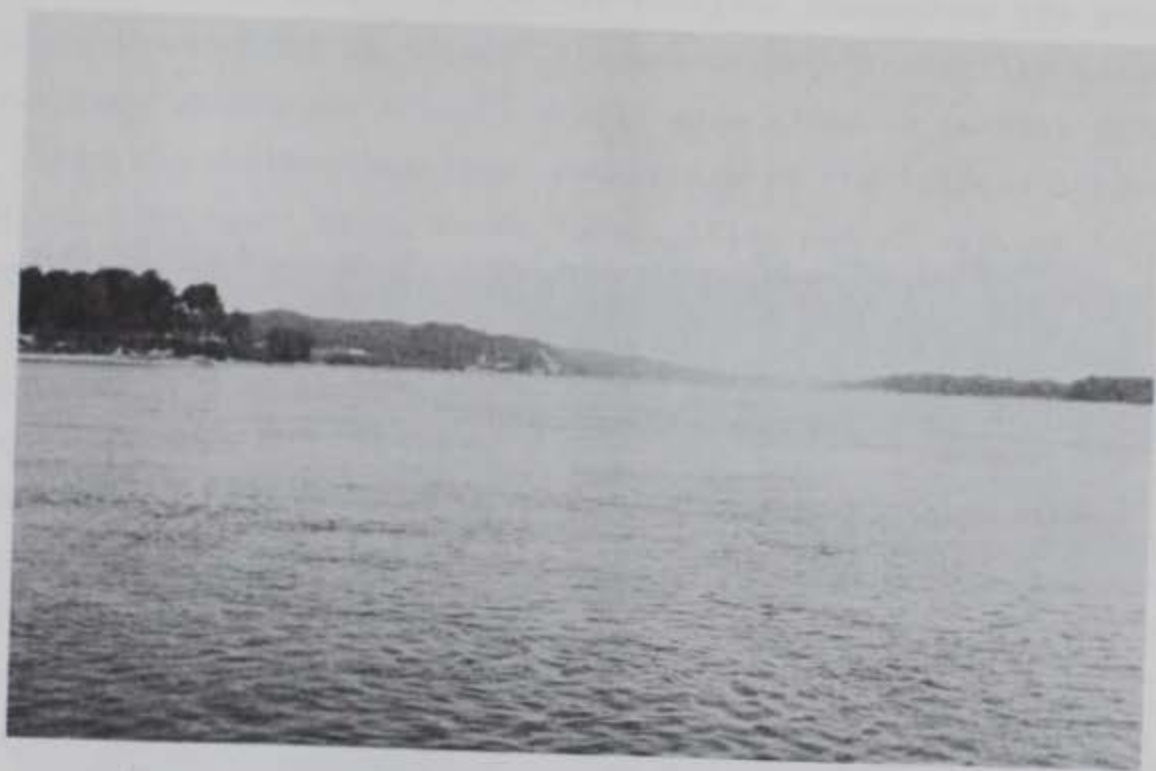

b. View upstream at approximately RM 71.5 of survey area (Grand Tower Chute is located 6 miles upstream.)

Figure 76. Representative views of channel in survey area





Figure 77. Survey boat approaching highway bridge at Chester, Ill., viewed upstream



Figure 78. Stone training dike of type used along Middle Mississippi River by the CE



and much of the bank lines along both sides of the channel have been riprapped with stone (Figure 79). A great deal of the riprap consists of handlaid stone blocks put in place during the 1930's. It was noted during the survey that this material is still in place and effective along much of the bank line. The channel is flanked by low, rugged hills along much of its course, particularly along the western bank in the survey area (Figure 80). Numerous rock exposures are situated along these areas. These rock exposures range from low rock ledges (Figure 81) to vertical rock faces over 100 ft in height at some locations (Figure 82). At some places along the channel bank, i.e., the bank line along the base of Fountain Bluff (Figure 83), large detached pieces of rock and rock boulders occupy much of the bank.

200. Numerous sandbar deposits were located throughout the survey area, generally associated with the convex part of bends in the channel and with islands. Side channels or chutes were noted along the reach of the channel surveyed. Many of these features had been closed off, either by bar development or by trail dikes constructed by the CE (Figure 84). As described above, rock outcrops are numerous throughout the survey area where the channel is located against or near the valley walls. Rock outcrops within the channel itself were noted in several areas, i.e., along the western bank just downstream of the railway bridge at Thebes, Mo.; at Tower Rock, Grand Tower, Ill.; and at various locations in Thebes Gap.

201. Visual observations made of the banks in the survey area during the survey indicated relatively few areas of the bank lines where actively caving banks were located. Most of the caving areas noted were situated in areas where the banks had not been riprapped or in the vicinity of the mouths of tributary streams entering the river channel. It was also noted at the time of the survey that large scour holes had developed on the downstream side of some of the stone training dikes jutting out into the channel. Some of the scour areas had eaten into the adjacent bank for various distances, causing a large circular section of the bank to be eroded away (Figure 85).

202. The channel bottom within the survey area displayed



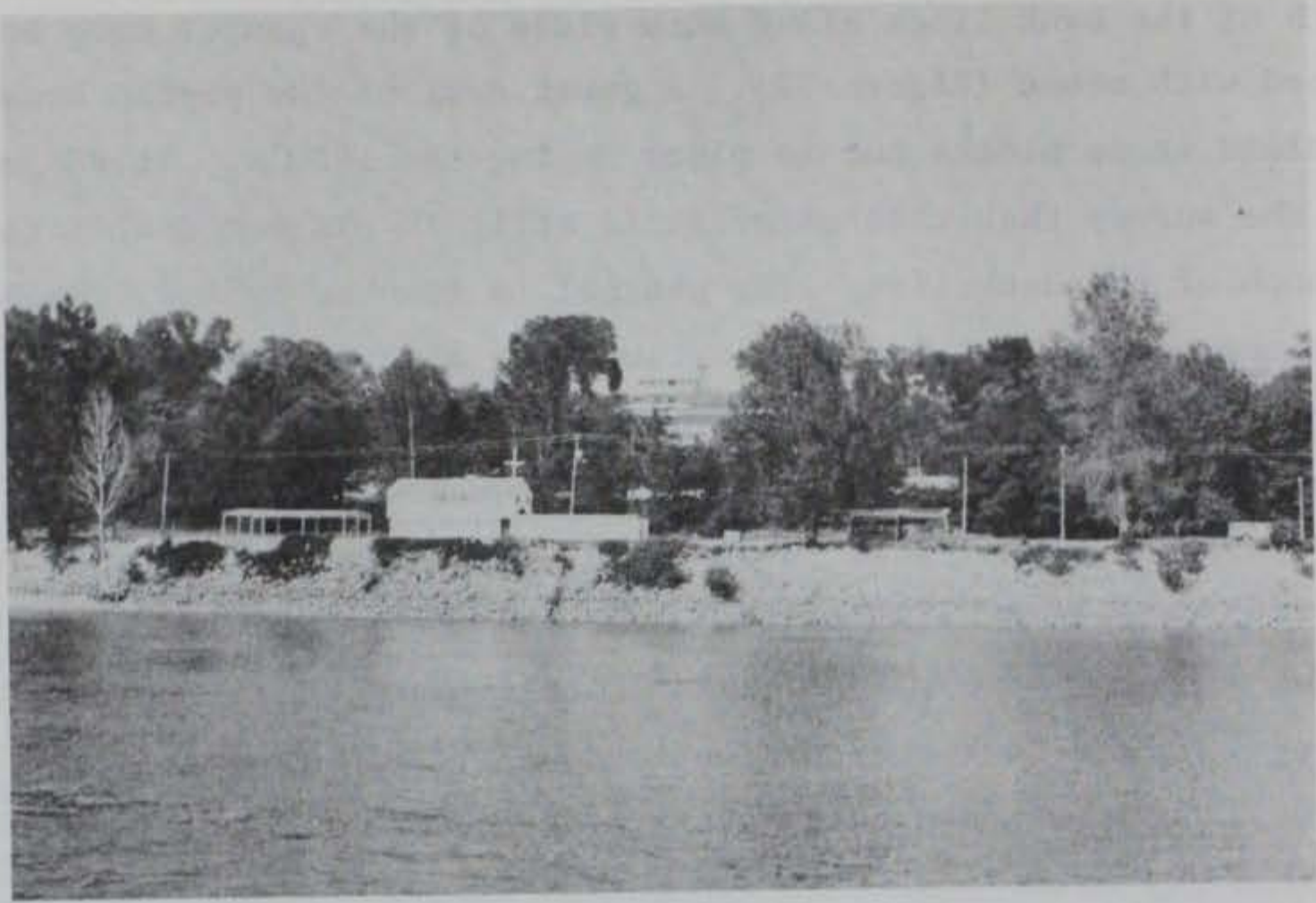

Figure 79. Heavily riprapped bank at Chester, Ill., a method of bank protection widely employed throughout the survey area

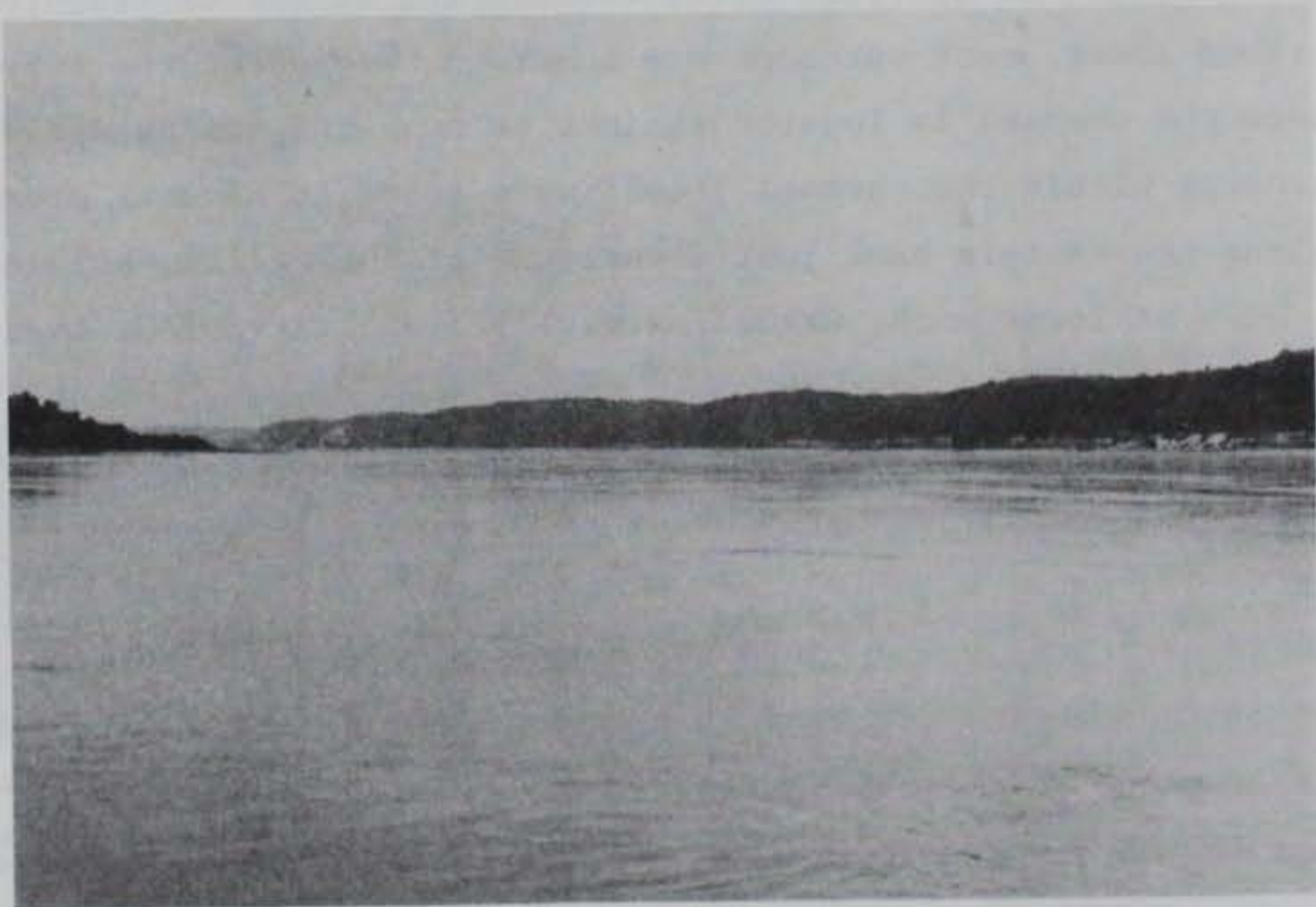

Figure 80. Downstream view from point just downstream of Grand Tower Chute (Light area in left center of photo is a rock bluff at RM 73.3 on west bank of channel. Low, forested hills as seen in this photo along the western bank line are characteristic of most of survey area.)





Figure 81. Rock ledges outcropping along bank line in vicinity of RM 74.0, west bank of channel

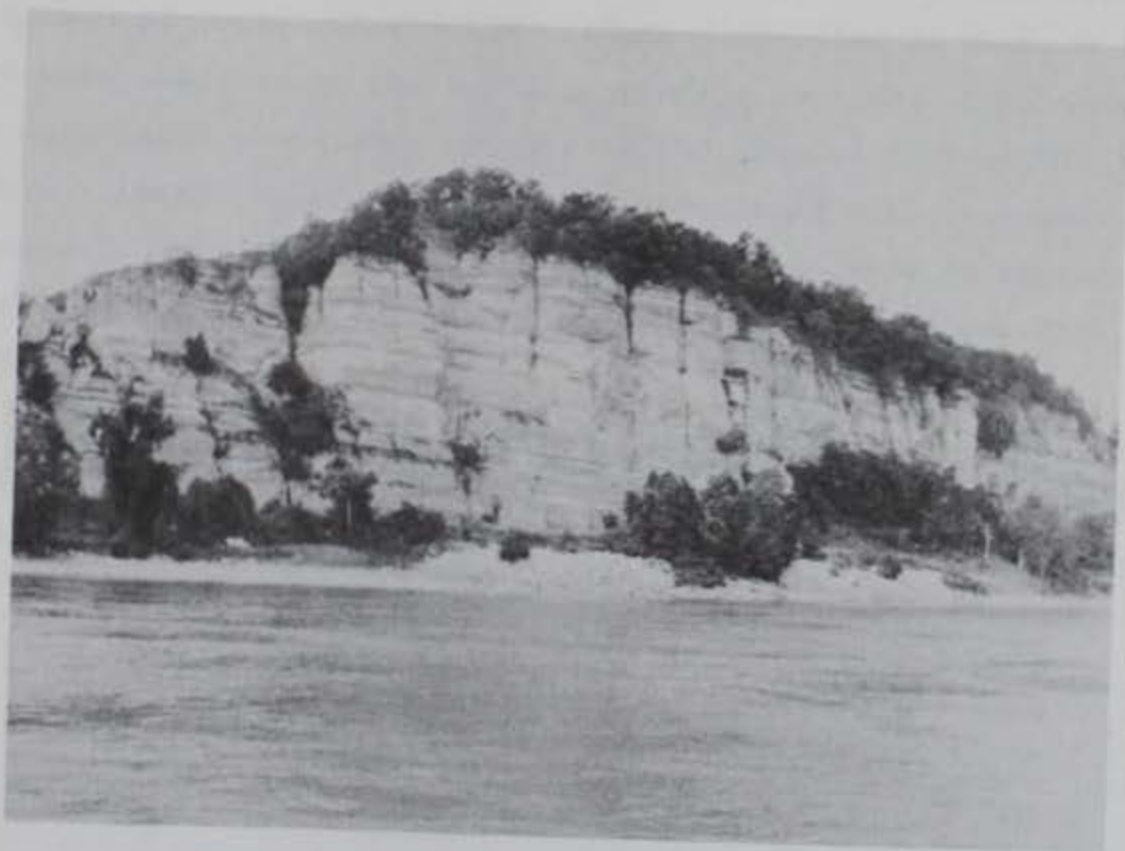

Figure 82. Upstream view along west bank in the vicinity of RM 68.7, almost vertical limestone bluff separated from water's edge by railroad





Figure 83. Large, detached pieces of rock along bank line at the base of Fountain Bluff at about RM 82.6 upstream from Grand Tower, Ill.



Figure 84. Side channel closure caused by sandbar development resulting from dike placement upstream of mouth of chute



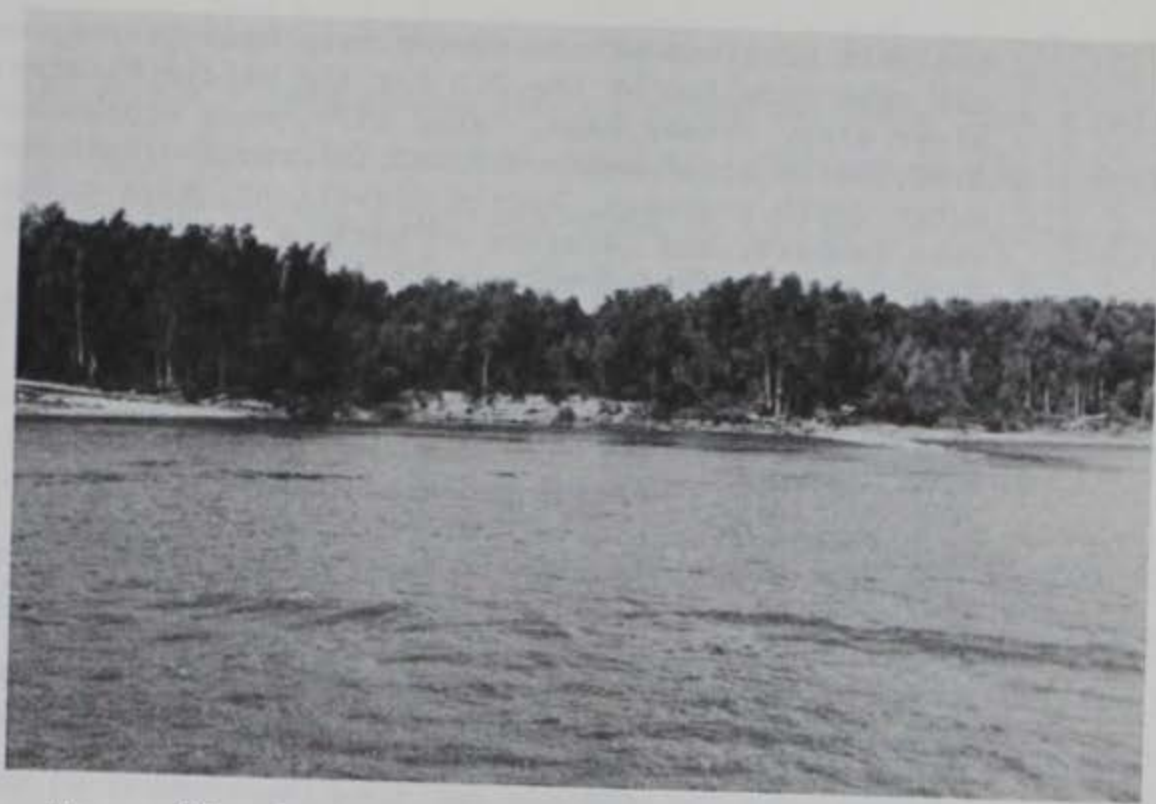

Figure 85. Large area of bank on downstream side of dike that has been eroded by scour action behind the dike

considerable variability. Some parts of the channel bottom appeared to be composed of rock. Distinctive ledges displaying as much as 10 ft of relief were observed on the acoustic profile records. Sand waves and dunes were noted along many reaches of the channel throughout the survey area. Large scour holes, usually associated with rock outcrops in the channel, were observed. Some of these holes were in excess of 100 ft in depth (depending on river stage), i.e., at Tower Rock and Cape Rock.

203. Availability of background and ground truth data. The following background and ground truth data were available for use during the various phases of the Middle Mississippi River acoustic profiling survey.

- a. Maps and charts. Topographic maps at a scale of 1:24,000 and 1:250,000, produced by the USGS, were used during all phases of the Middle Mississippi River acoustic profiling survey. A few geologic maps, produced by the Illinois State Geological Survey and the Missouri Geological Survey, were available for various areas within the survey area. These maps were generally based upon standard USGS quadrangles, scale 1:62,500. Of particular assistance during the field survey and data



analysis portions of the survey were hydrographic survey maps compiled by the SLD for the Middle Mississippi River area. These maps, dated 1976, were approximately 1:10,000 in scale and contained information such as water depth contours, bottom elevations, mile numbers, dike numbers, and location of various natural and man-made features in and adjacent to the channel. The base format of the hydrographic charts is aerial photography that is overlaid with data of the nature described above.

- b. Soil and rock borings. Soil and rock boring data were generally scarce for the immediate survey area of the channel. Three bridges crossing the Mississippi River at Thebes and Cape Girardeau, Mo., and at Chester, Ill., provided the only available deep borings within the channel or immediately adjacent to it. Foundation borings drilled during site investigation studies at the Kaskaskia Locks and Dam at the upper end of the survey area provided data concerning the depth of bedrock below the alluvium in that area. However, most of these borings were located too far from the channel of the Mississippi to provide direct correlation with the acoustic records.
- c. Miscellaneous. Various published documents concerning groundwater investigations, geologic investigations, and miscellaneous studies conducted in and around the survey area provided some information of significant use to the study.

204. Survey procedures. The acoustic profiling operations at the Middle Mississippi River survey site consisted generally of a single, continuous profile line inside the marked navigation channel. The position of profile lines generally coincides with the deep-water portions of the channel, although portions of the acoustic data are located in shallow-water zones of the channel due to avoidance of towboat traffic. Three separate profile lines were obtained in that part of the channel located between RM 36, below Commerce, Mo., and RM 51.0 at Cape Girardeau, Mo., because of the interest of the SLD in the location of rock outcrops situated in this reach of the river. The boomer CSRP system and the side-scanning sonar system were generally operated concurrently throughout the survey period. Location of the survey lines was accomplished by position fix marks made at various dikes located on either side of the channel. These dikes, numbered and shown on the hydrographic charts used during the survey, provided good position



fix targets throughout the survey area.

205. The side-scanning sonar towfish was towed from a point near the bow of the barge (Figures 86 and 87) which was used as a work platform during the survey. The deck crane on the barge provided an excellent location from which the towfish could be towed away from boat engine noise and vibration effects. Furthermore, since the boomer sound source and hydrophone array were towed from the stern of the towboat, the two systems were separated by a margin wide enough to minimize interference between the two profiling systems.

206. Data analysis. The quality of the acoustic profile records acquired along the Middle Mississippi River survey area was generally very good. Current velocities during the survey period were low to moderate as would be expected for the time of the year. Some noise signatures were introduced to the acoustic records during passage of towboat traffic. However, this source of interference was of an intermittent nature and did not seriously affect the overall quality of the records. Penetration of the channel bottom sediments within the survey area by the Uniboom profiling system was generally achieved throughout the survey area. The side-scanning sonar system detected a host of bottom parameters including old barge and boat wrecks, rock outcrops, various sediment waveforms, and changes in bottom composition. Representative examples of acoustic data obtained during the acoustic survey follow below.

207. CSRP data. The profile in Figure 88 crosses a well-known fault zone known as the Ste. Genevieve fault system which crosses the Mississippi River channel just south of Wittenberg, Mo., into Illinois at Grand Tower. The large interpreted rock outcrop (D) located in the channel may be associated with the fault zone. The outcropping is in alignment with a bedrock ridge which terminates at the Missouri shoreline and an elongated rock ridge known as Backbone that is located on the Illinois shore. The three rock units are essentially in alignment, oriented northwest-southeast. The Mississippi has apparently broken through this alignment at some point in its history and the rock in the channel may be erosional remnants. The rock surface (D) dips below the





Figure 86. Towing configuration used for side-scanning sonar towfish during Middle Mississippi River acoustic survey, towfish approximately 5 ft below surface of water



Figure 87. Retrieval of side-scanning sonar system towfish



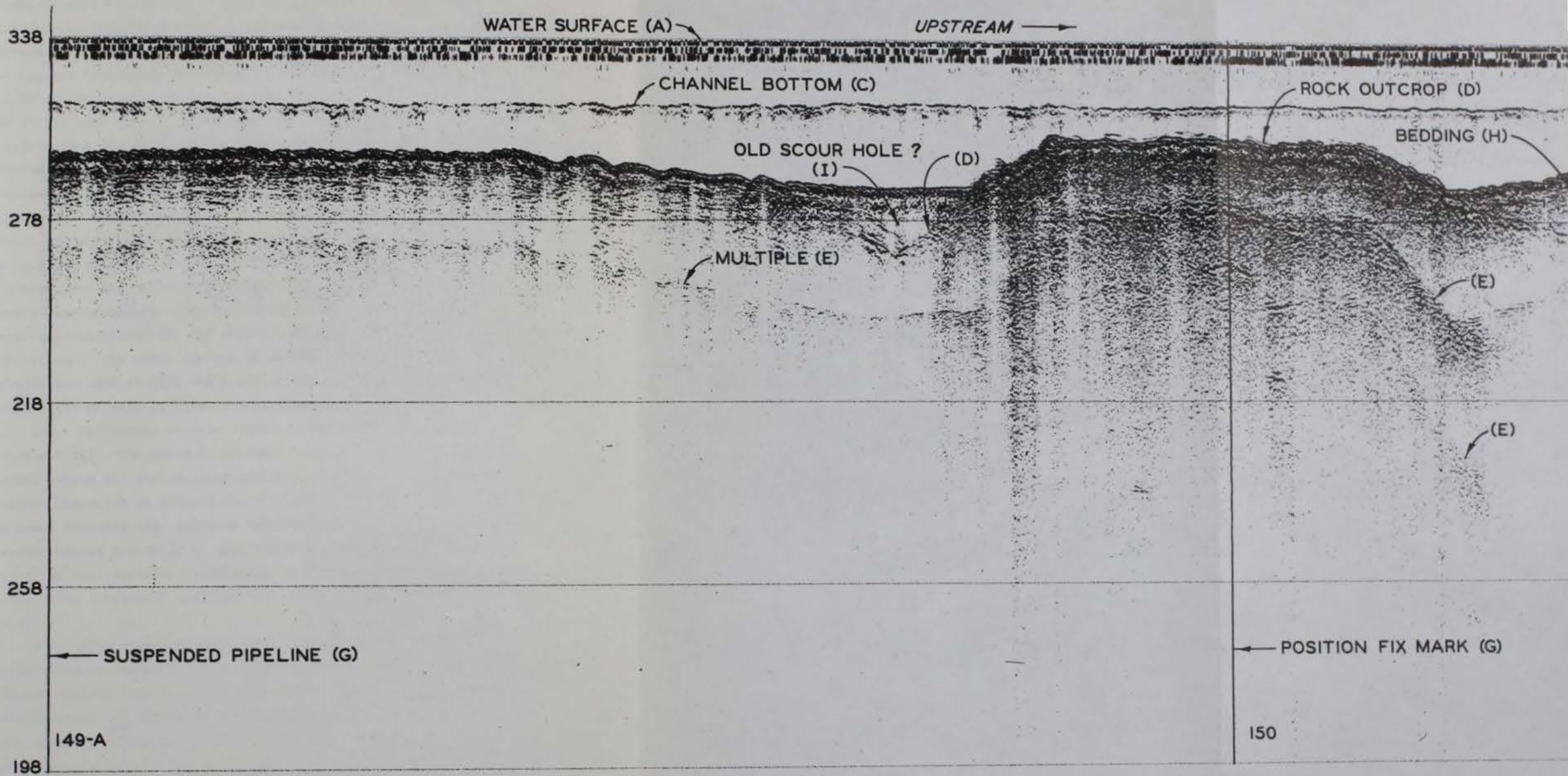
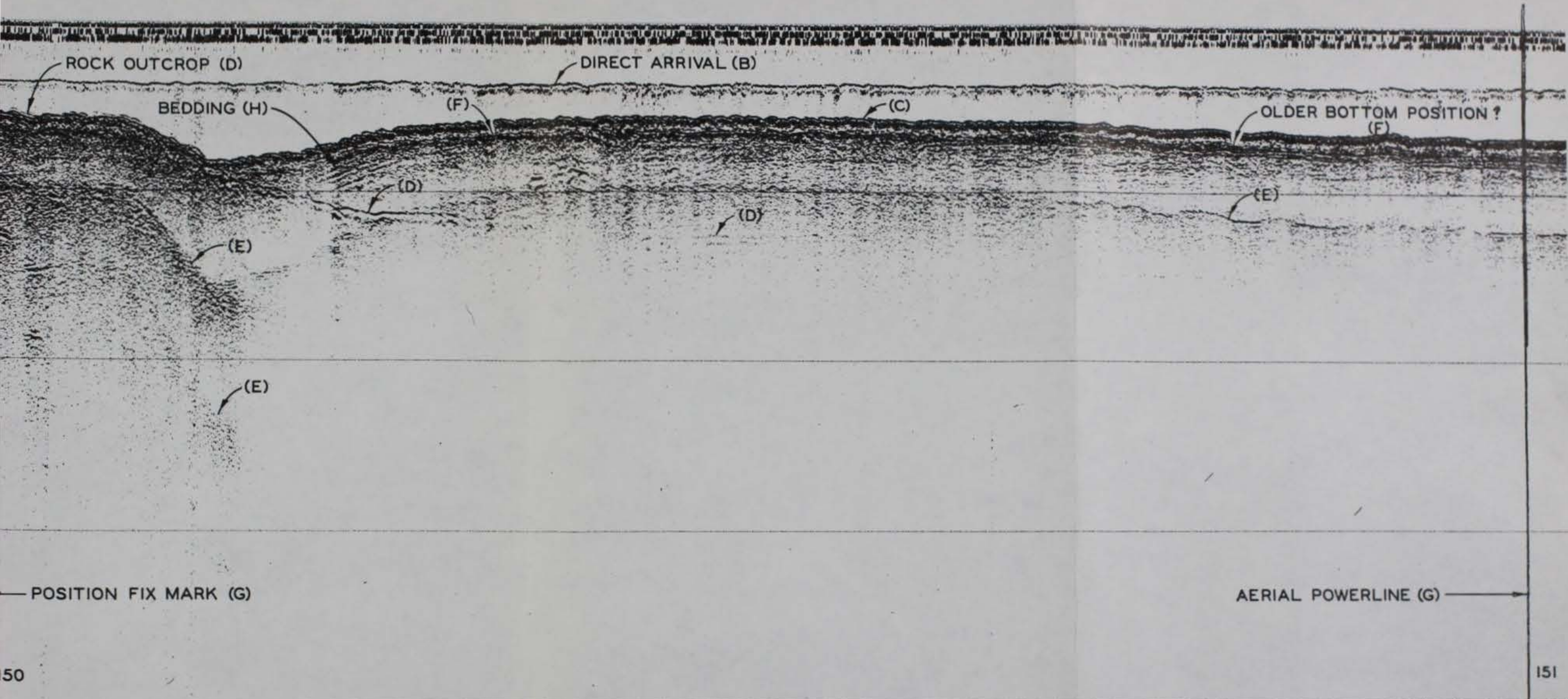

Figure 88. Boomer record, Middle Mississippi River, Grand T





... record, Middle Mississippi River, Grand Tower, Ill., vicinity of RM 80



present channel bottom (C) on both upstream and downstream sides of the exposed rock. The buried top of rock can be followed a short distance upstream before losing it. Downstream of the rock exposure, the top of rock appears to increase in elevation and may be situated just a few feet below the channel bottom. An old scour hole (I) appears to have been filled with recent sedimentation. The exposed rock ledge probably extends across the full width of the channel. The bedding (H) in the alluvium overlying the bedrock surface (D) reflects cyclic sedimentation processes that are probably in response to the position of the rock outcrop (D). If one visualizes the rock outcrop as being akin to a natural low sill structure where accretionary processes are active on the upstream side and scouring processes on the downstream side of the structure, the accretionary bedding (H) and old scour hole (I) are readily understandable. The more recent sediment deposition over the former channel bottom (F) may also be influenced by the location of the rock outcrop. The water surface is at (A), direct arrival at (B), multiple reflections at (E), and position fix marks at (G). The horizontal scale of the profile is 1 in. = approximately 200 ft.

208. The boomer profile record in Figure 89 intersects a boat wreck (C). The wreck is probably actually resting on an older channel bottom (D) and has been partially buried by river sedimentation. The wreck is responsible for the buildup of sediment around the wreck site and also upstream and downstream of the site. The present channel bottom is at (A), water surface at (B), direct arrival at (G), multiple reflections at (E), and position fix marks at (F). The horizontal scale of the record is approximately 1 in. = 200 ft.

209. Side-scanning sonar data. The record in Figure 90 illustrates the development of large sand waveforms (A) that produce conspicuous channel bottom record signatures. Dike 107.5 (B) produces a turbulent zone (C) extending downstream from the end of the dike. The dark, linear patterns (D) probably represent the acoustic return from the downstream face of the sand waves that, because of the steeper slope, reflect a greater amount of acoustic energy. The dark, irregular bottom

2  
where



areas (E) are thought to be areas of high reflectivity due to topographic variations of the channel bottom, or changes in sediment type, i.e., sand to gravel, etc. The channel bottom is at (G). The towfish symbol in the center of the record represents the position of the transducer relative to the port and starboard portions of the graphic record. The horizontal scale of the record is approximately 1 in. = 200 ft.

210. The remains of a steamboat (see boomer record, Figure 89) that sank in the Mississippi River in the early 1900's are clearly seen in this side-scanning sonar record obtained in the vicinity of RM 109 at Chester, Ill. (Figure 91). The boat is lying in about 30 ft of water and is oriented roughly perpendicular to the channel flow. The bow of the boat is at (A) and the stern is at (B). The boat is a point source for alluvial deposition and has been partially buried by sediment (D). The channel bottom is at (C). The horizontal scale is approximately 1 in. = 200 ft.

#### Results of survey

211. Side-scanning sonar data acquired in the Middle Mississippi River survey area provided useful information pertaining to the nature and characteristics of the channel bottom. Sediment bedform data acquired with the side-scanning sonar provided a means to map the distribution of bottom unconsolidated sediments versus those portions of the bottom composed of rock. The side-scanning data also provided locations of submerged structures and objects such as dikes, sunken barges and boats, and pipelines. Information pertaining to the effect of these features on sediment deposition and scour can be acquired through the use of side-scanning sonar.

212. CSRP data acquired in the Middle Mississippi River survey area provided significant information pertaining to the location, distribution, and type of bedrock located on the bottom and 5 to 50 ft below the bottom of the channel. This information in this area has more significance in terms of hazards to navigation rather than channel erosion.



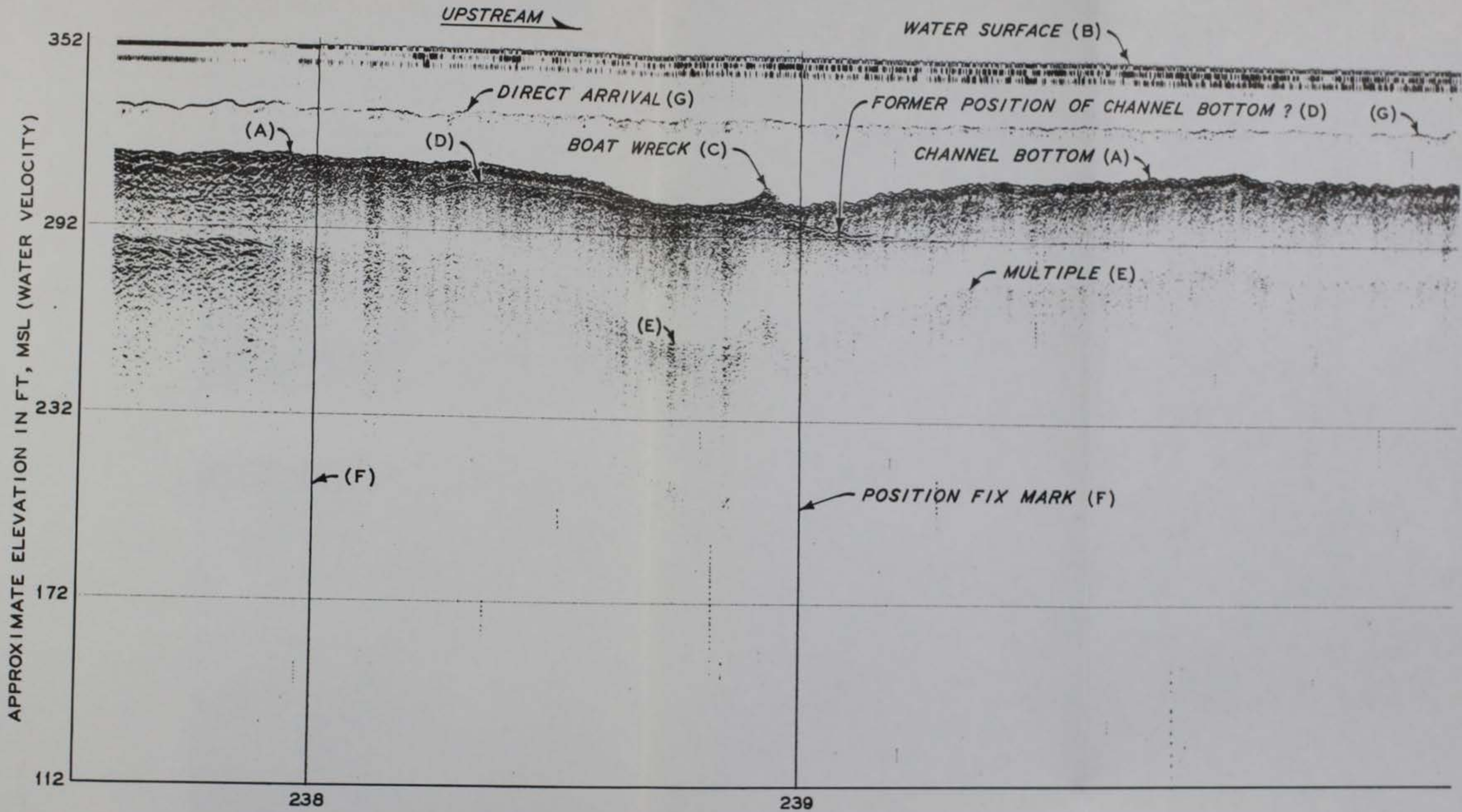

Figure 89. Boomer profile record, Mississippi River, near Chester, Ill. (Remains of a steamboat which sank in the early 1900's is evident on the record.)



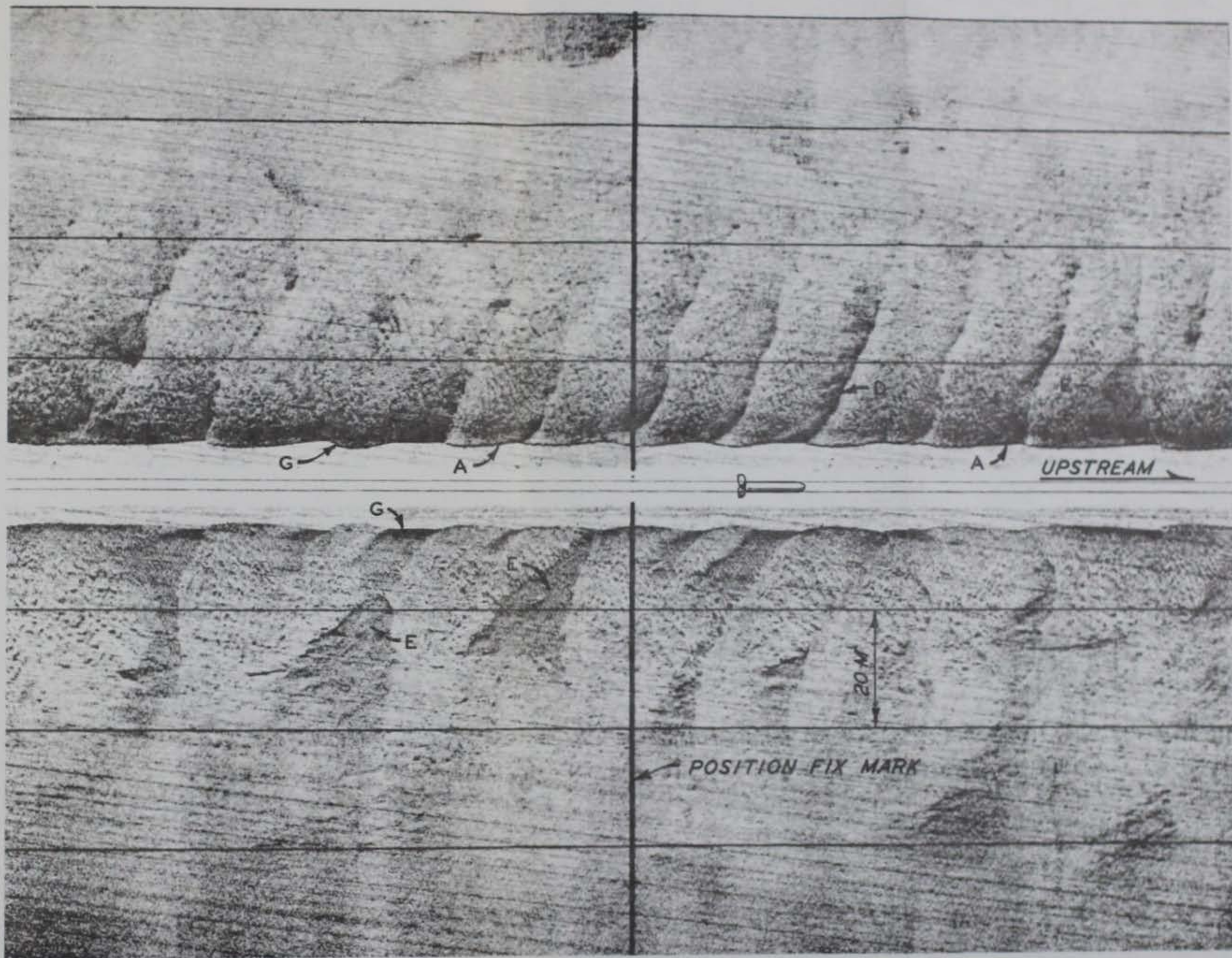

Figure 90. Side-scanning sonar record obtained in the Mississippi River at RM 107 near Chester, Ill., showing development of large sand wave forms



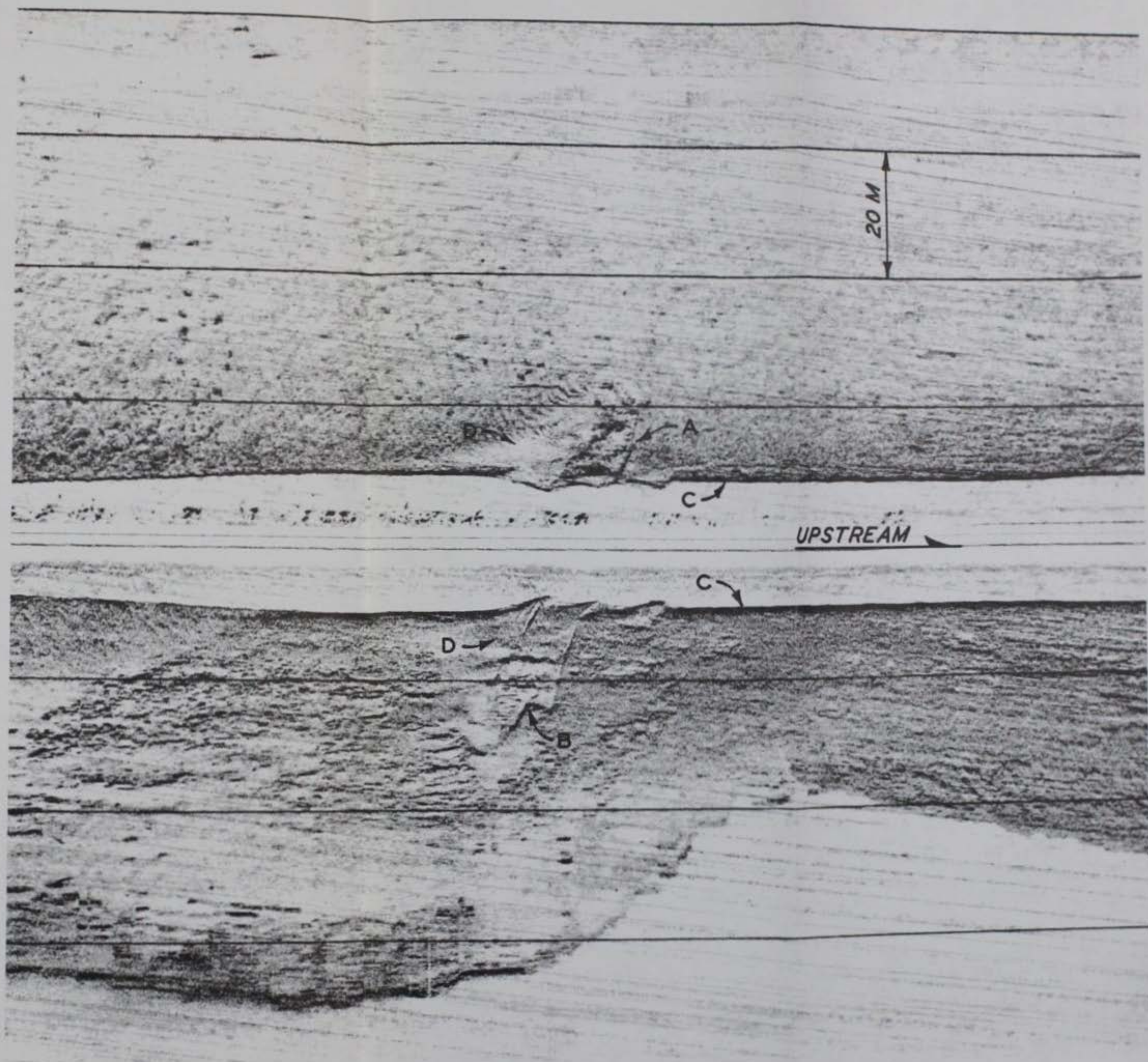

Figure 91. Side-scanning sonar record of Mississippi River channel at Chester, Ill., showing remains of a river steamboat which sank in the early 1900's



## Missouri River Survey Sites

### Location

213. Acoustic profiling operations were conducted in seven reaches of the Missouri River between Omaha, Neb., and Sioux City, Iowa. The various reaches where acoustic profile data were obtained are listed below and are also shown on the location map in Figure 92:

- a. Reach 1, RM 610, immediately downstream of the Douglas-Sarpy County, Nebr., boundary to RM 630, near the Washington-Douglas County boundary.
- b. Reach 2, RM 641, downstream from DeSoto Lake to RM 644.4. Nearly all of this line is situated in the DeSoto Lake Cutoff.
- c. Reach 3, RM 690, approximately one-half mile south of Decatur, Nebr., to RM 697, about one-half mile downstream of the mouth of Blackbird Creek.
- d. Reach 4, RM 705, two miles south of the Winnebago and Omaha Indian Reservations boundary line to RM 710.
- e. Reach 5, RM 708.5, near the Woodbury-Monona County, Iowa, boundary line intersection with the river to RM 713 near the Dakota-Thurston County, Nebr., boundary line.
- f. Reach 6, RM 717 to RM 720.5
- g. Reach 7, RM 727, about one mile upstream from Dakota City, Nebr., to approximately RM 734 at the mouth of the Big Sioux River, Sioux City, Iowa.

### Physiographic and geologic setting

214. The Missouri River from Sioux City, Iowa, to Omaha, Neb., (Figure 93) flows through its alluvial floodplain which ranges in width from about 3.5 miles at Omaha to almost 20 miles at its widest point approximately 20 miles south of Sioux City. The valley is flanked on the west and east by irregular bluffs which are generally 200 ft or more above the valley floor. The bluffs, generally composed of bedrock, glacial till, and veneered by wind-deposited silt (loess) of Pleistocene age, are dissected by numerous tributary streams entering the valley floodplain. The valley floodplain exhibits very low relief from bluff to bluff, broken only by alluvial plain features such as abandoned channels, oxbow lakes, and those features attributable to man. Terraces,



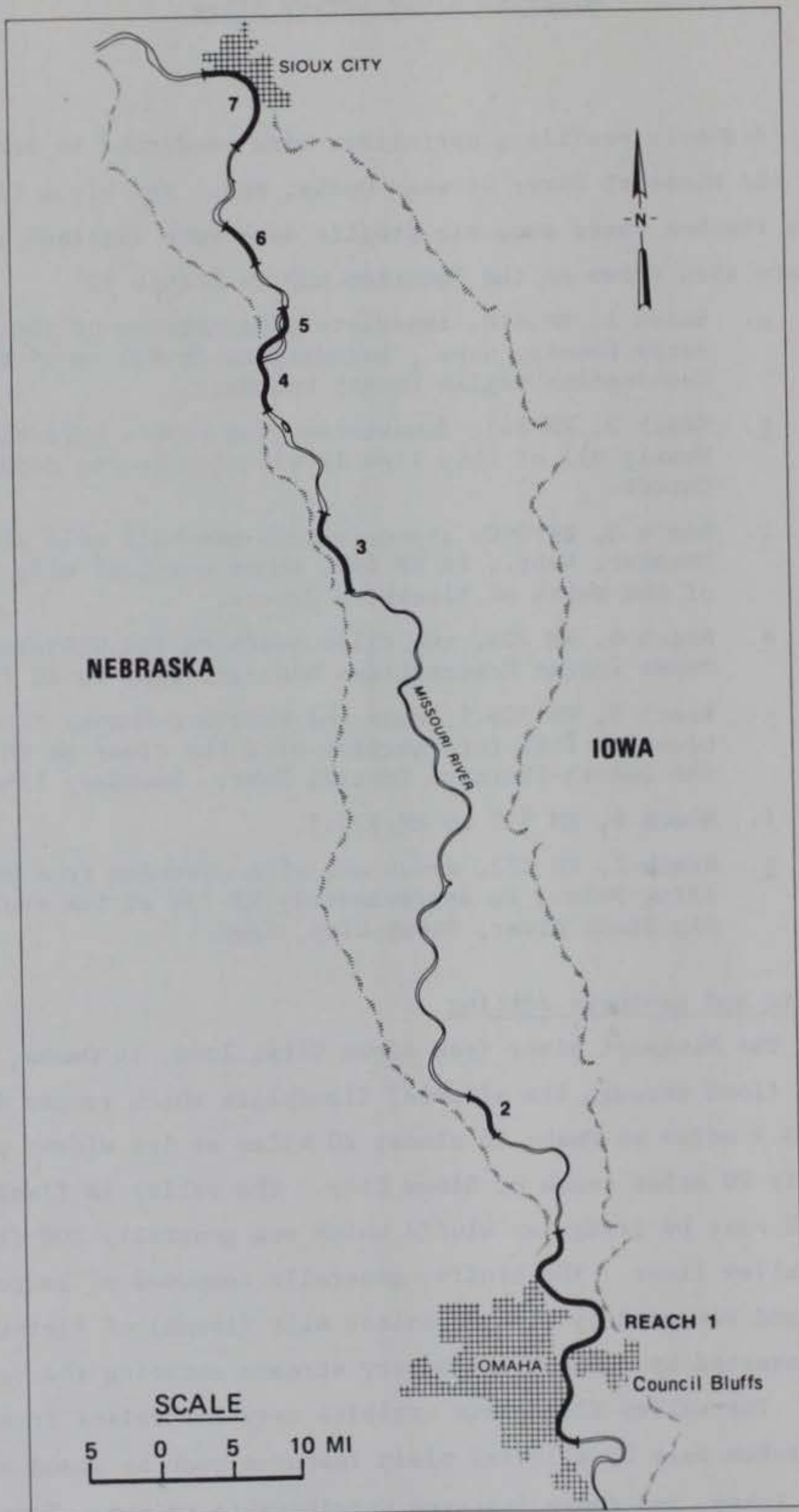

Figure 92. Location map of Missouri River acoustic survey sites



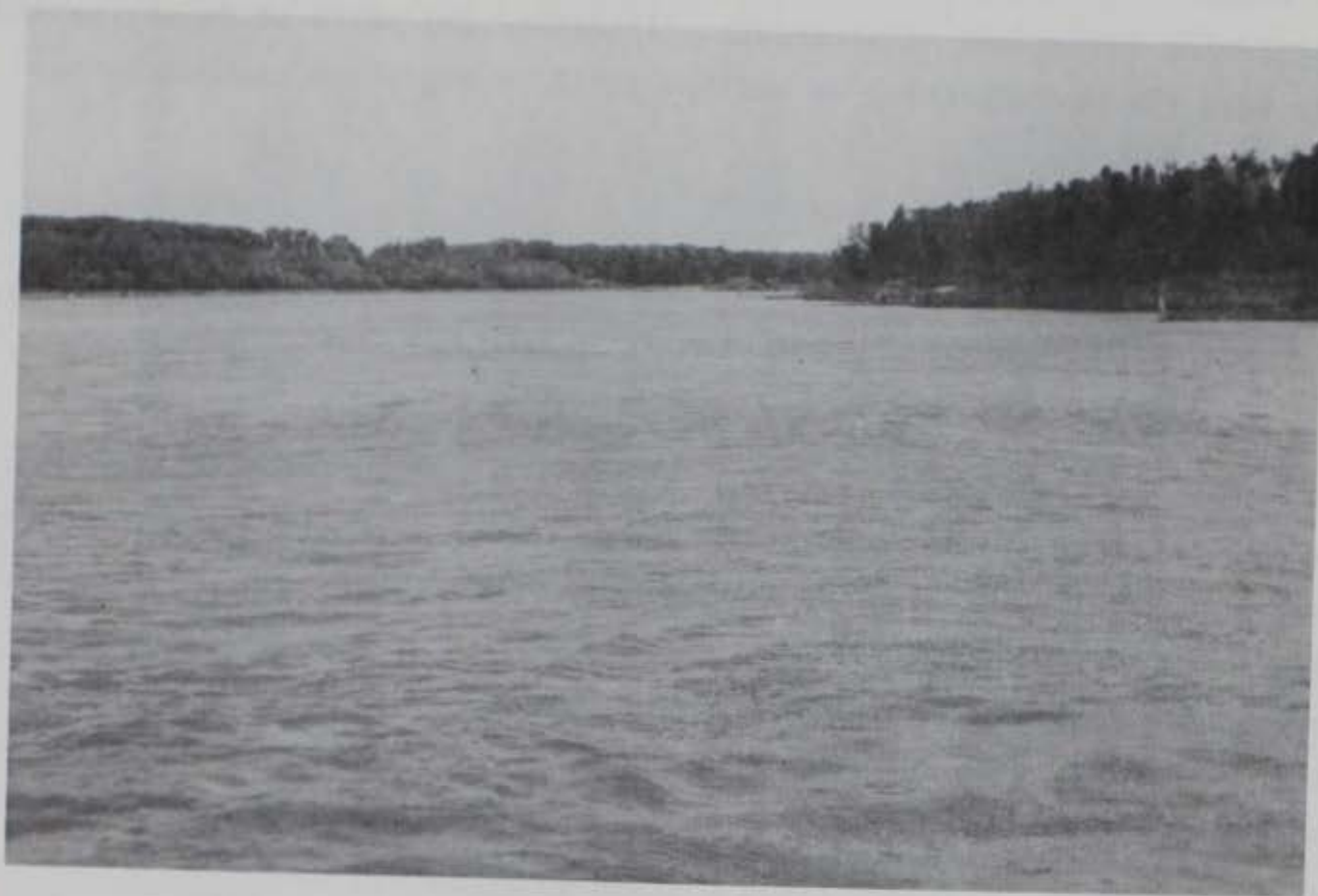

Figure 93. Missouri River between Omaha, Nebr. and Sioux City near Decatur, Nebr.

representing older floodplain deposits, are located between the uplands and the Missouri River floodplain. The terraces generally range in height from 25 to 80 ft above the valley floor (Miller 1964).

215. The surface of the Missouri River floodplain is generally composed of silt and clay deposits associated with the alluvial environments of deposition, although fine sand also occurs on the surface in some areas. Alluvial deposits beneath the surface alluvium of the Missouri River floodplain are composed principally of sand and fine gravel (Miller 1964). Bedrock formations below the alluvial floodplain between Omaha and Sioux City are generally 100 ft or deeper except in those areas where the Missouri River impinges on the bluffs along the valley walls. At these points available data suggest that rock is at very shallow depth below the river channel, and in some places the river appears to have eroded down to the bedrock surface. Test borings made before the construction of the Interstate 480 bridge over the Missouri River



at Omaha show deposits of unconsolidated Recent and Pleistocene materials overlaying formations of alternating limestone and shale of Pennsylvanian age with the bedrock being as shallow as 12 ft below the channel bottom (Burchett 1965).

#### Background of bank erosion problems

216. Acoustic profiling operations conducted on the Missouri River were initiated at the request of the Missouri River Division (MRD), CE to provide bottom and subbottom data for input to ongoing and future channel degradation studies conducted by the MRD. Channel degradation within the Missouri River survey area and other reaches of the river system is generally believed to be a result of dam construction and channel improvement projects, i.e., cutoffs (Personal Communication, Omaha Engineer District (OED), 1978). Since channel degradational processes are generally a significant factor contributing to streambank erosion, the MRD and WES were interested in acquiring high resolution acoustic bottom and subbottom data along selected reaches of the Missouri River channel to evaluate the technique's application to degradation monitoring and measurement. Some active bank caving was observed in several reaches of the channel. These areas were primarily confined to old channel spoil disposal sites and stretches of the bank line where coarse-grain sediment constituted the predominant soil type (Figure 94).

#### Implementation of survey

217. The acoustic profiling survey conducted on the Missouri River between Omaha and Sioux City was accomplished during the period 11-17 June 1978. The survey operations were conducted in an incremental fashion commencing at Omaha and working in an upstream direction to Sioux City. A general description of the Missouri River acoustic survey is contained in the following paragraphs.

218. Support equipment and personnel. The MRD furnished a 65-ft boat, MANDAN (Figure 95), and operating personnel for support of the acoustic profiling survey. The OED also furnished various personnel to assist in optimum location of acoustic survey lines and for general guidance throughout the duration of the survey. Survey operations were conducted for most of the period from the OED maintenance base located





Figure 94. Section of actively caving bank line on the Missouri River bank composed of heterogenous mixture of materials of dredged spoil material



Figure 95. The MRD boat, MANDAN, used by WES for support of the Missouri River acoustic profiling survey



at Omaha, Nebr. The remainder of the survey period was spent working out of Sioux City, Iowa, in the upper reaches of the survey area. No electronic positioning systems were employed for horizontal control of the acoustic survey lines because of the extent of the survey area and the time constraints imposed on the length of the survey period. OED personnel furnished location control during the survey by furnishing position fixes as the survey boat passed numbered dikes, navigation aids, and other control points of a permanent nature.

219. Acoustic survey systems used. Two acoustic profiling systems were used during the Missouri River acoustic survey program. The EG&G Uniboom CSRP system was used for the acquisition of subbottom data, and the Klein Associates Hydroscan side-scanning sonar system was used for obtaining high resolution bottom data. The Model 262 and 265 EG&G hydrophones were used in conjunction with the Uniboom system.

220. Configuration and characteristics of the survey area. The Missouri River from Omaha, Nebr., to Sioux City, Iowa, (the limits of the survey area) is part of an authorized 9-ft project navigation channel developed and maintained by the CE. The surveyed reach of the river is a multicurved, open navigation channel with no locks or pooled areas (U. S. Army Engineer District, Omaha 1971). The channel width ranges from about 600 ft to 1500 ft in the survey area. The channel is characterized by numerous dikes and revetments on both sides of the river such as shown in Figures 96 and 97. Two types of dikes are prevalent in the survey area--pile dikes and stone-fill dikes. Because of their greater durability, stone-fill dikes have replaced the pile dikes for use as channel training structures. Piles, asphalt, concrete, and stone revetments have been used along the bank lines to prevent scour of the banks (Figure 98). However, nearly all new revetments are presently constructed of stone.

221. During the period of the survey, current velocities and turbulence levels were high due to the release of water from upstream flood-control reservoirs. The main channel environment consisted of the open navigation channel with the highest current velocities and water depths ranging from about 15 to 35 ft. The bottom sediments appeared to be



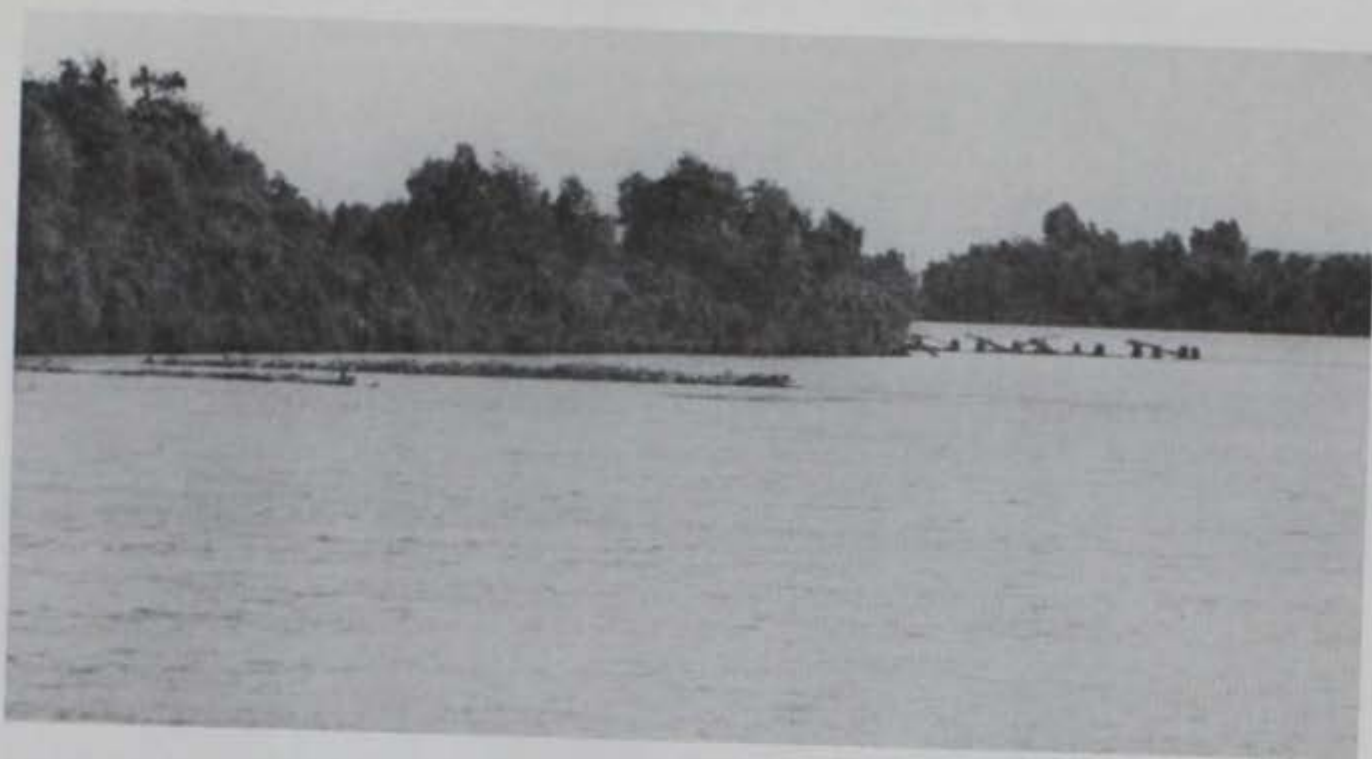

Figure 96. Training dikes along a stretch of bank line on the Missouri River (Stone dike can be seen in the middle of the photo with an older type pile dike in the background.)



Figure 97. Older style pile revetment used for bank protection on the Missouri River



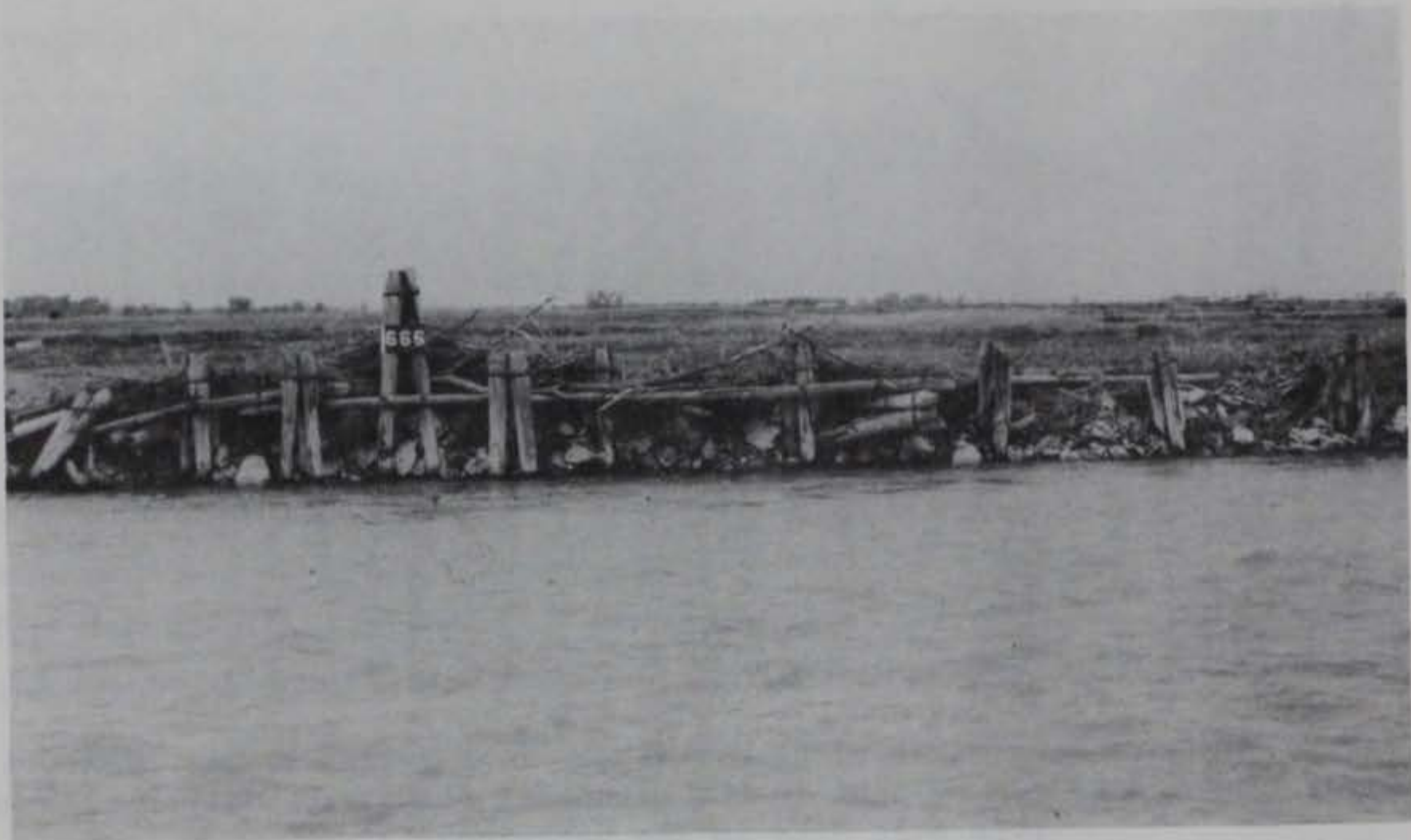

Figure 98. Bank line characterized by older piling and stone revetment (These revetments are being replaced by stone revetment protection as the older revetment becomes ineffective.)

composed predominantly of fine and coarse sand based on observed waveforms typical of sandy bedload. Some areas of the channel bottom appeared to be composed of rock outcrops. Many chutes, or side channels, were located along both sides of the channel surveyed. Deepest water depths occurred in those portions of the channel near the end of the training dikes. Bank lines along the surveyed portion of the Missouri River were characterized by varying bank heights. Sediment types composing the banks appeared to be predominantly sandy silts and silty clays. Although no detailed measurements of bank heights were made, they appeared to range from about 2 ft along low, point bar areas to over 100 feet where the channel was impinging on steeply sided bluff areas.

222. Availability of background and ground truth data. The following background and ground truth data were available and used during various phases of the Missouri River acoustic survey:



- a. Maps and charts. Topographic maps compiled by the USGS at scales of 1:24,000 and 1:250,000 were used during all phases of the Missouri River survey. In addition, special construction drawings on a map base of 1:10,000 scale were particularly helpful during the survey for establishing position fix marks on the acoustic records. These drawings were prepared by the OED in 1977 and show river miles, numbered dikes, and other pertinent structures along the channel and adjacent bank areas.
- b. Soil borings. The OED furnished WES with boring logs and locations that are held in various OED files. These borings are from various sources and include CE borings made in conjunction with degradation studies along various reaches of the Missouri River, foundation borings drilled at various bridge crossings within the survey area, and foundation borings that were made prior to plant construction along the banks of the Missouri River. Nearly all of the foundation borings were drilled to bedrock and were very helpful in correlating reflections on the acoustic records with the elevation of top of bedrock formations.

223. Survey procedures. Because of the large area of channel requested for acoustic survey by the MRD and OED during the Missouri River survey operations, acoustic profile lines were limited generally to a single line approximately along the channel thalweg. The EG&G Uniboom and Klein Hydrosan side-scanning sonar systems were operated concurrently during all phases of the survey. The Uniboom system was operated in the towing configuration depicted in Figure 99. The hydrophone was placed approximately 6 ft from the source with the center element placed directly opposite the middle of the catamaran transducer. The towing point for the Uniboom was from the starboard quarter of the stern. The Klein towfish was towed approximately 6 ft in depth below the surface of the water from a point near the bow of the boat on the port side. The seven reaches of the river in which profile lines were acquired, as shown in Figure 92, were profiled by "leap-frogging" upstream from Omaha to Sioux City. The WES survey team was furnished guidance by OED representatives onboard the survey boat for selection of channel reaches to be profiled. As mentioned previously, no formal positioning technique was used during the survey. The acoustic records were marked with locations of numbered dikes, mile markers, and other



Figure 99. Towing configuration used with Uniboom CSRP system during Missouri River survey operation (Hydrophone component is to the left of the source in the photo; the black linear object is the tow cable and flotation material situated immediately ahead of the active section of the hydrophone.)



permanently positioned visual landmarks.

224. Data analysis. The overall results of the acoustic profiling operations during the Missouri River survey were generally good. The quality of the boomer records was diminished somewhat by strong, turbulent currents prevalent within the channel throughout the survey. The numerous eddies, boils, etc. created a noisy surface and near-surface environment that affected the performance of both source and hydrophone arrays. However, the side-scanning sonar records were generally excellent, considering the adverse environmental conditions present within the channel.

Side-scanning sonar data

225. Because the side-scanning sonar record format may not be very familiar to readers of this report, a brief discussion of record format and characteristics of Figure 100 is included in the discussion



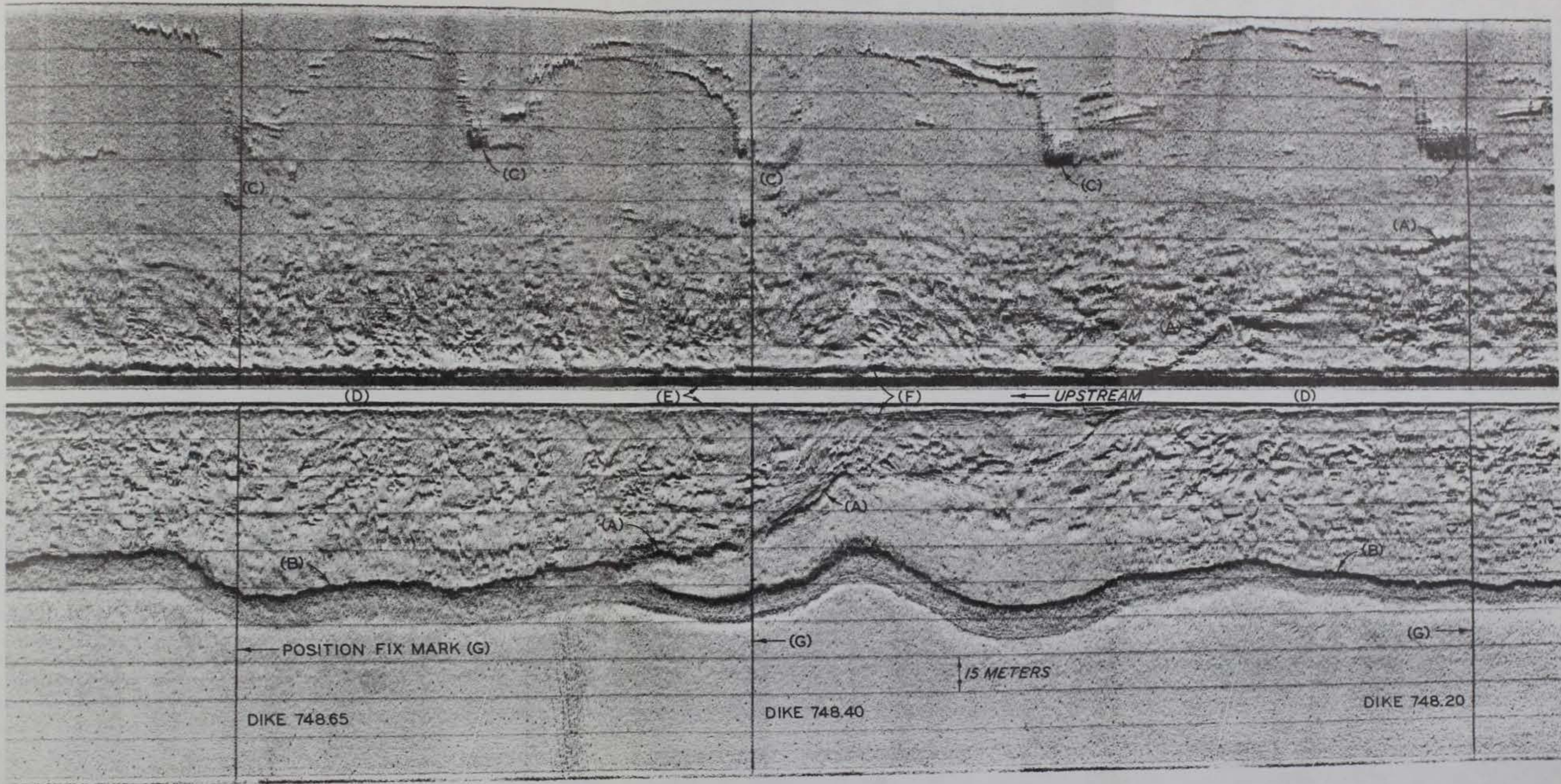

Figure 100. Side-scanning sonar record, Missouri River between RM 693 and 694



of this record only for general guidance to the reader. The linear, white gap running across the middle of the record (D) is the position of the towfish. The heavy dark parallel lines (E) on either side of the gap are the initial radiated pulse signatures that are always present on the record. The bottom trace, or depth profile (F), is recorded for both channels of data along the inside portion of the record. A conspicuous linear feature (A) extends diagonally across the river channel from the toe of the right bank (B). This feature is interpreted as the remains of older bank protection structure that has been abandoned because of channel realignment by the CE. The features (C) are the riverward ends of stone training dikes along the right bank of the river (left and right bank is terminology used by CE to denote the sides of a river channel, the direction of which is gained by the downstream view of the channel). Position fix marks are (G). The horizontal scale of the record is 1 in. = 200 ft approximately.

226. The profile (Figure 101) shows a lengthy, continuous segment of the toe of a bank protection revetment (B). The revetment is constructed of stone riprap. The curvy nature of the revetment is due to horizontal deviations in the tracking of the towfish. Localized slumping of the bank material underlying the revetment is clearly apparent at (C) where the stone protective cover has moved out with the underlying bank material. These bank failures are probably in a very early stage and could possibly be arrested by timely remedial measures before additional slumping occurs at the affected points along the toe of the bank. The channel bottom profiles are at (A), stone training dikes along the left bank are at (D), and position fix marks at (E). The horizontal scale of the profile is 1 in. = approximately 200 ft.

227. The profile (Figure 102) shows a section of the river channel that contains a large area of rock (A) that extends from the toe of the right bank to points near the middle of the channel. The riverward limits of the rock formation appear to have been shaped and scalloped by the erosive action of the river. Note the difference in texture of the area interpreted as rock and the adjoining channel bottom area (H) which is composed of sand. The rock is probably limestone of



the Wyandotte formation of Pennsylvanian age which borings indicate is at shallow depths below the channel in the vicinity of the Interstate 480 bridge. Barges moored along the right bank display dark linear record signatures (B). The reflection signatures (C) contained on the starboard channel of the side-scanning sonar record are spurious and are caused by "crosstalk" between port and starboard circuitry in the towfish. Crosstalk generally occurs when the reflected energy is of the extremely high amplitude levels characteristically produced by metallic or other hard objects. Parts of stone training dikes are evident at (D). Bottom sediment waveforms, probably sand waves, are at (E). Note that waveforms are not evident within the area interpreted as rock (A). Position fix marks are at (F), and the bottom profiles at (G). The horizontal scale of the record is 1 in. = approximately 200 ft.

228. The profile (Figure 103) along this particular reach of the Missouri River channel shows a lengthy segment of the right bank (B) riprapped with stone that is interrupted by the mouth of the old channel of the Floyd River (C). (The new channel and mouth are located a short distance further upstream.) Small, localized slumps (D) occur at widely spaced points along the toe of the right bank. Piers supporting the Chicago and Northwestern railway bridge are located at (F). Anomalous channel bottom targets are at (G), stone dikes at (E), channel bottom profiles at (A), and position fix marks at (H). The horizontal scale of the profile is 1 in. = approximately 200 ft.

229. The profile in Figure 104 shows a large slump area (A) occurring at the toe of the bank protection structure situated along the right bank (B). Bank and revetment material have moved approximately 100 ft downslope from the toe of the revetment. Moored barges are at (C); an artifact reflection from barges is at (D); stone training dikes are at (E); channel bottom profiles at (F); and position fix marks at (G). The horizontal scale of the record is 1 in. = approximately 200 ft.

#### Results of survey

230. A number of subaqueous bank failures were detected by side-scanning sonar in various reaches of the Missouri River survey area. Although some bank failure zones were evident above the waterline,



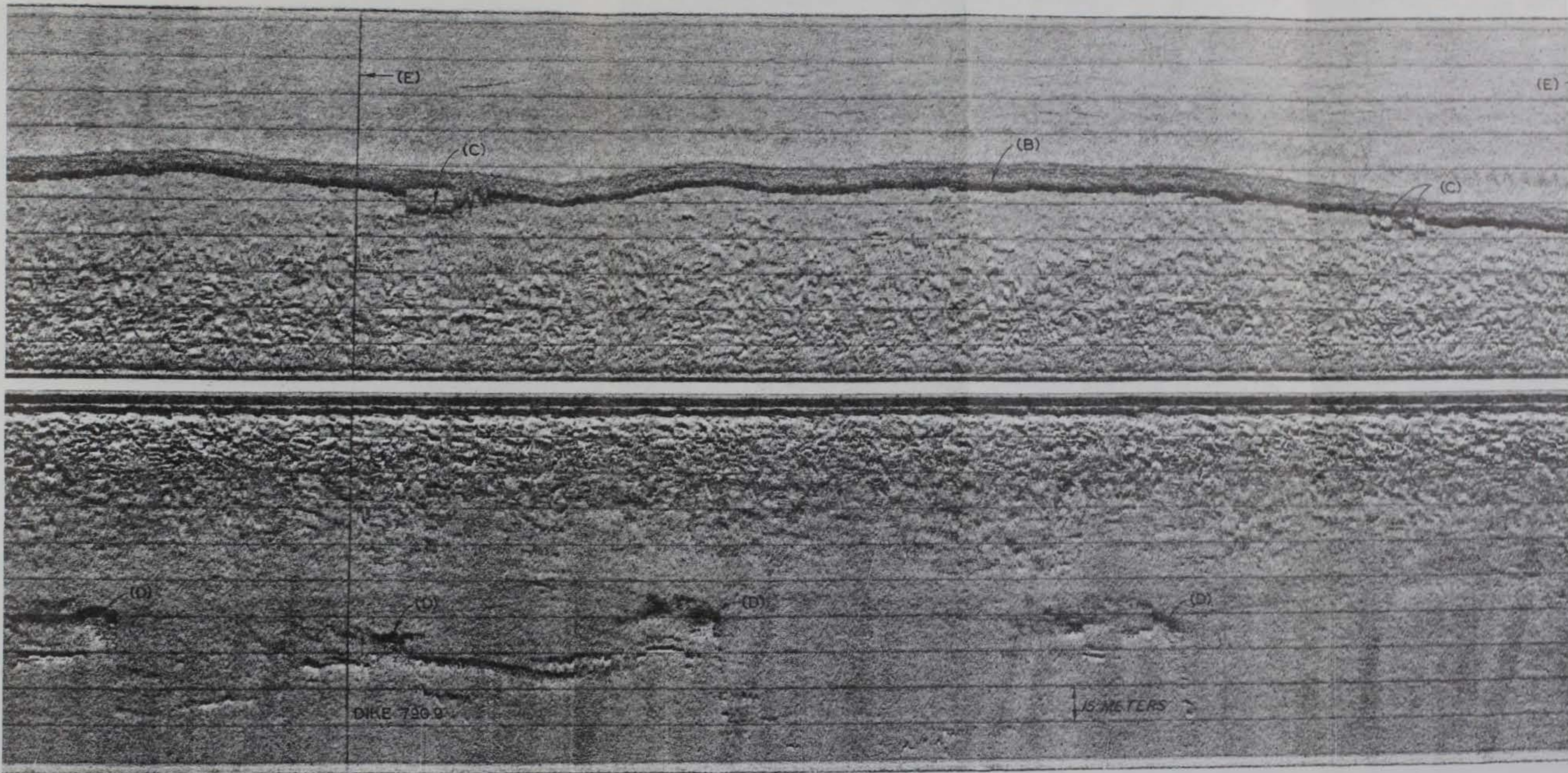

Figure 101. Side-scanning sonar record, Missouri River between RM 719 and 720



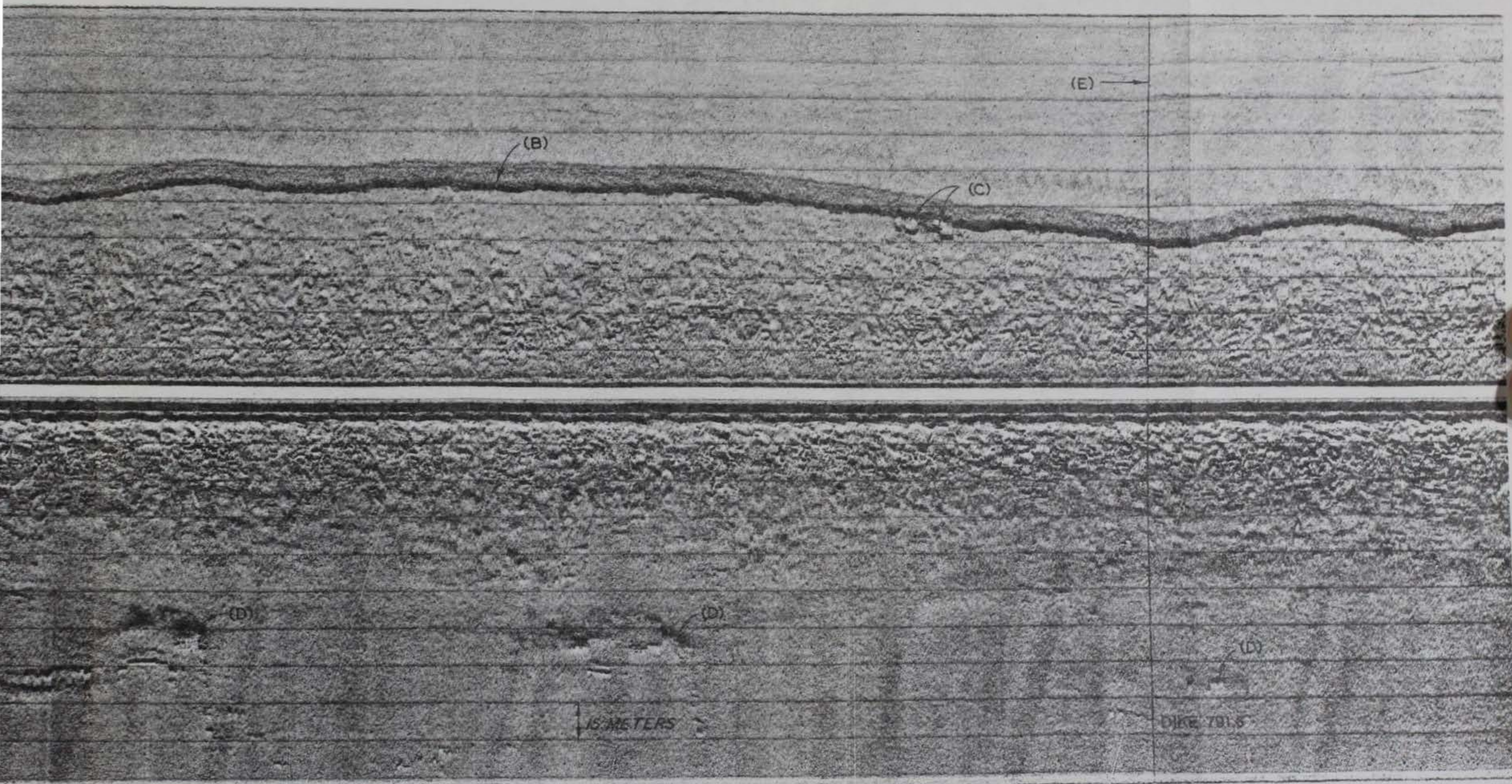

Figure 101. Side-scanning sonar record, Missouri River between RM 719 and 720



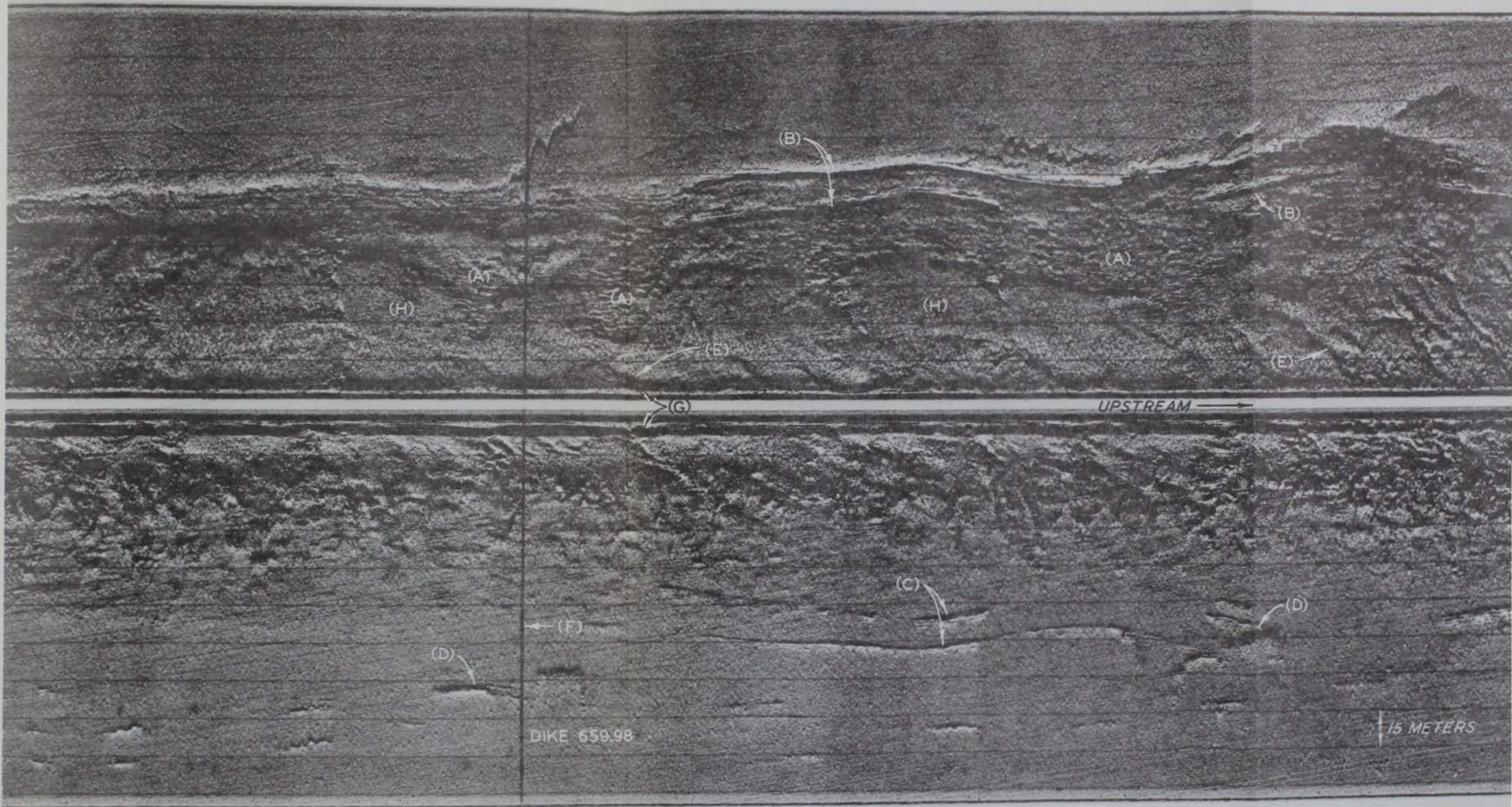

Figure 102. Side-scanning sonar record, Missouri River, in the vicinity of RM 616, upstream of Interstate 480 bridge



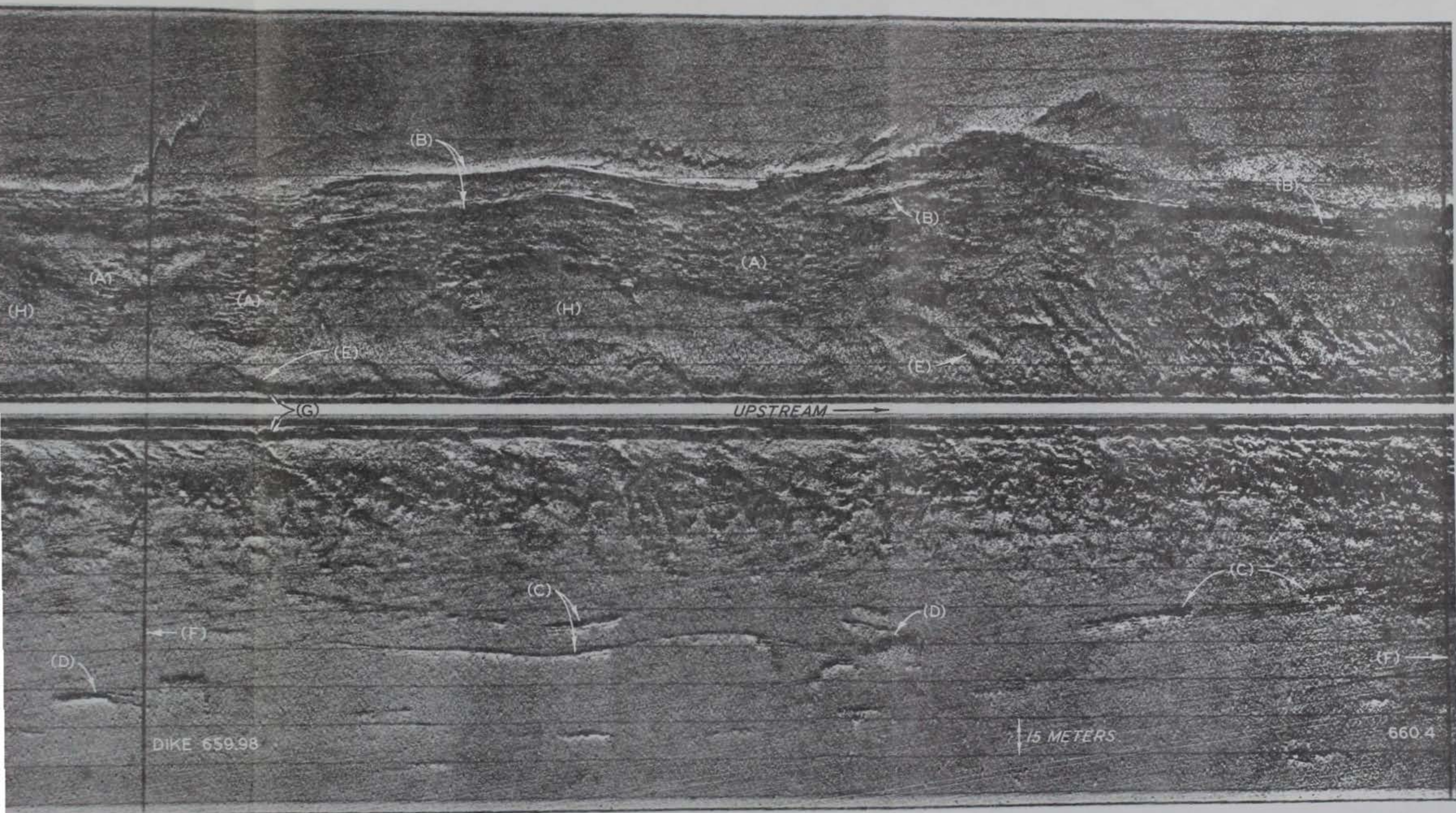

Figure 102. Side-scanning sonar record, Missouri River, in the vicinity of RM 616, upstream of Interstate 480 bridge



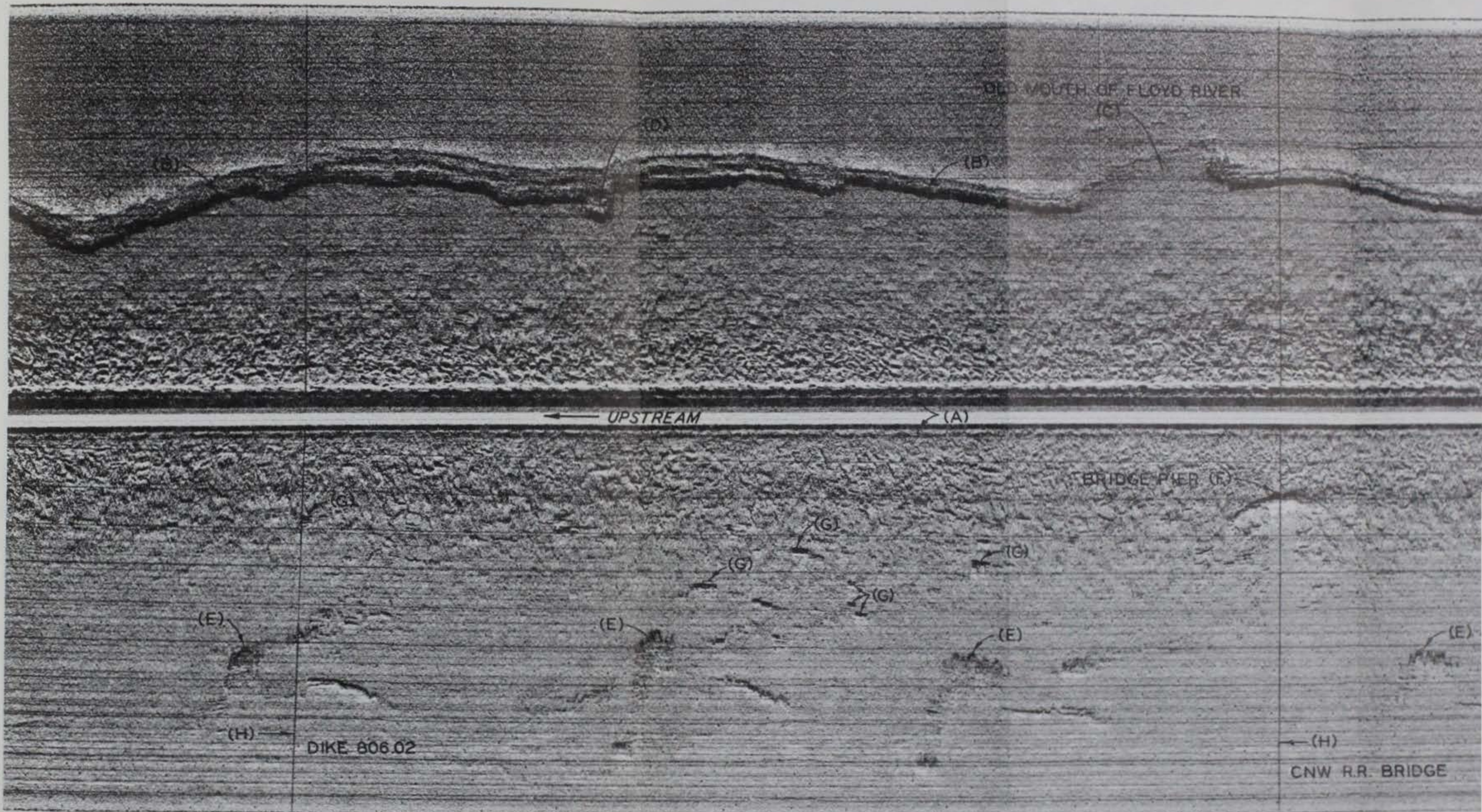

Figure 103. Side-scanning sonar record, Missouri River, Sioux City, Iowa, between RM 730 and 731



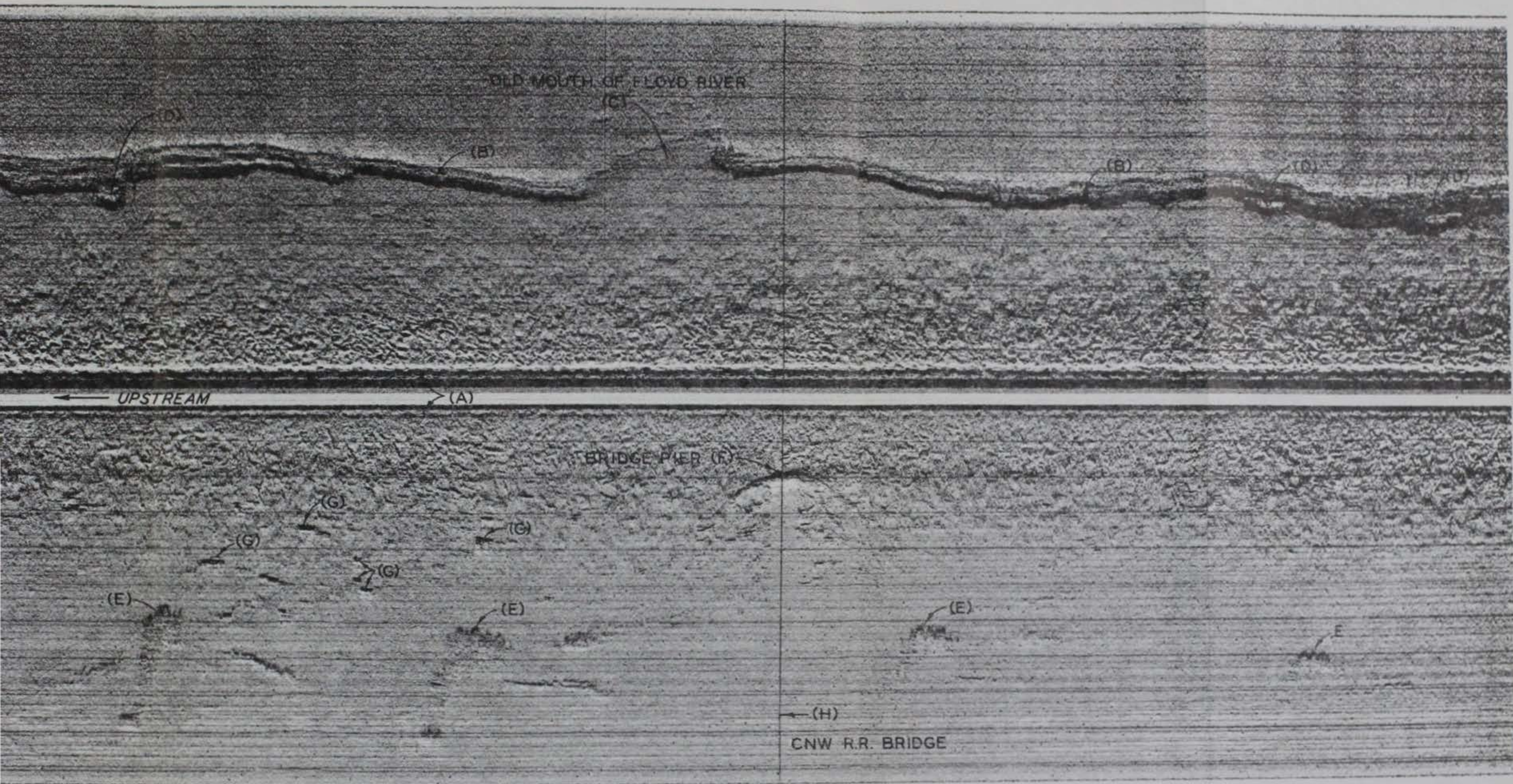

Figure 103. Side-scanning sonar record, Missouri River, Sioux City, Iowa, between RM 730 and 731



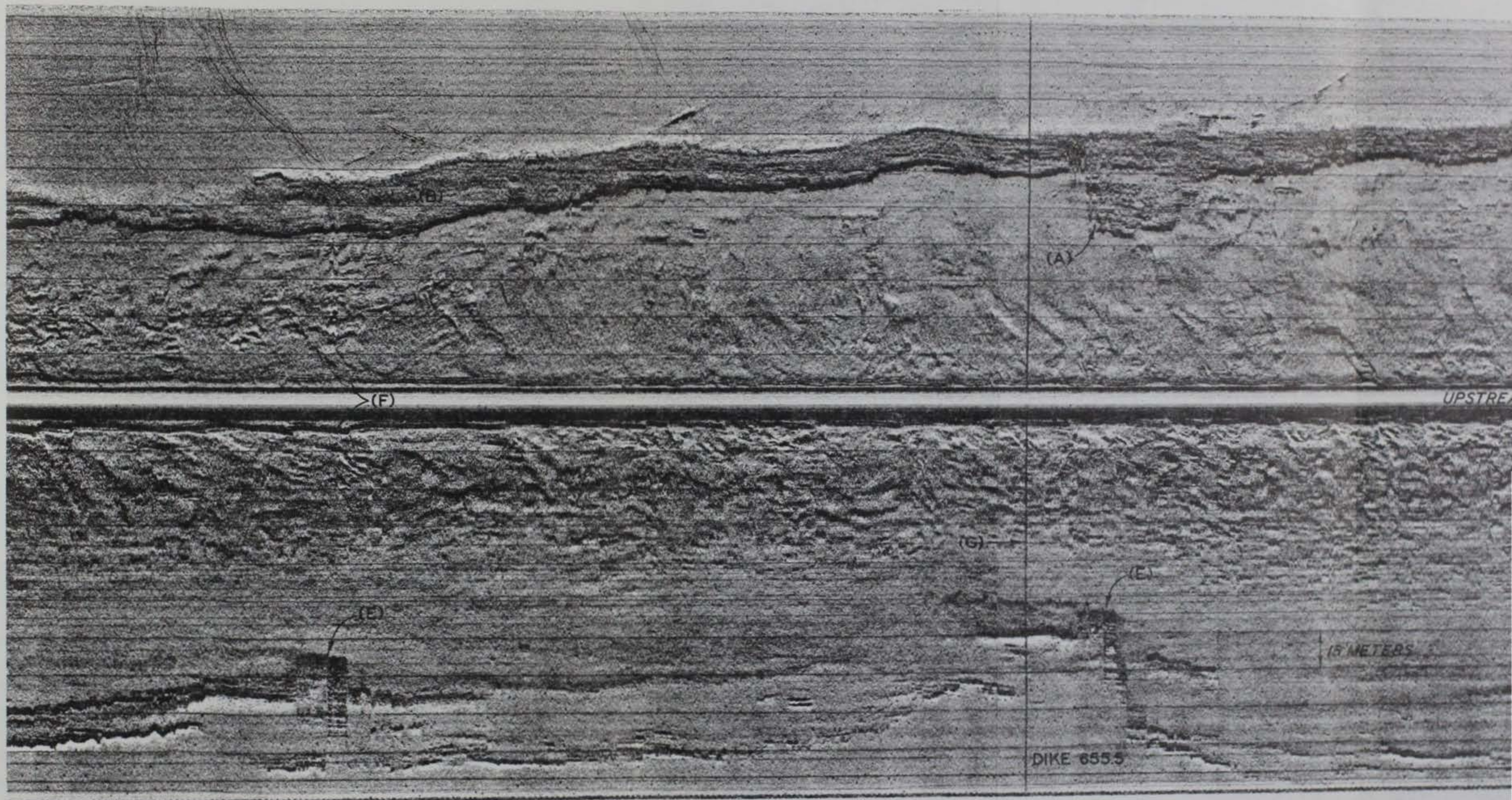

Figure 104. Side-scanning sonar record, Missouri River, Omaha, Nebr., between RM 611 and 612



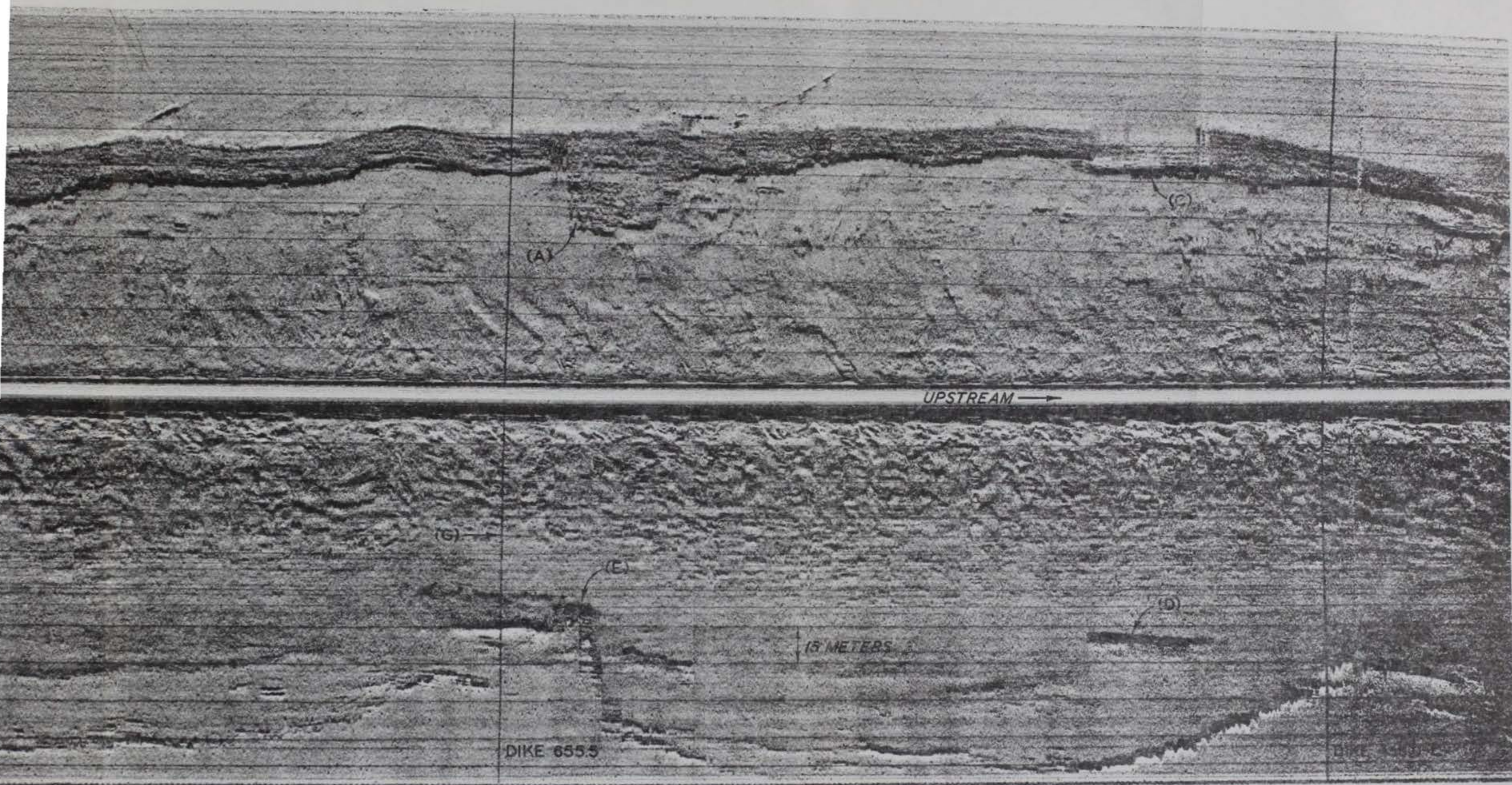

Figure 104. Side-scanning sonar record, Missouri River, Omaha, Nebr., between RM 611 and 612



others were not. The records indicate that some of the underwater failure zones are confined to the lower bank areas either because of geological controls, or because they are of recent origin and have not developed sufficiently to affect the upper bank areas.

### Ohio River Survey Sites

#### Location

231. Acoustic profiling operations were conducted on four reaches of the Ohio River located between Gallipolis and Cincinnati, Ohio. The subject reaches of the river are located in the Meldahl and Greenup Pools. The Meldahl Pool extends from Greenup Locks and Dam (RM 341) downstream to Meldahl Locks and Dam (RM 436). The Greenup Pool extends upstream from Greenup Locks and Dam to Gallipolis Locks and Dam (RM 279.2). Normal pool elevation for Meldahl and Greenup Pools is 485 and 515 ft msl, respectively. The various reaches (locations shown in Figure 105) where acoustic profiling data were obtained are listed below:

- a. Reach 1, Meldahl Pool--Charleston Bar Light, RM 414, (about 2.5 miles upstream from the mouth of Eagle Creek, Ohio) to Wrightsville, Ohio, RM 391.8.
- b. Reach 2, Meldahl Pool--Cummins Landing Light, RM 389.1, (about three-fourths of a mile downstream of Brush Creek Island) to the mouth of the Scioto River, Portsmouth, Ohio.
- c. Reach 3, Meldahl and Greenup Pools--Portsmouth, Ohio, RM 354.5, to Ashland, Ky. (U. S. Highway 60 bridge, RM 322.8 approximately).
- d. Reach 4, Greenup Pool--RM 302, (about 2 miles upstream of Huntington, W. Va., near the mouth of Three Mile Creek) to Gallipolis Locks and Dam (RM 279.2).

#### Physiographic and geologic setting

232. The portions of the Ohio River where acoustic profiling operations were conducted flows through a narrow valley that is generally flanked on either side by low, rugged hills and ridges that have been heavily dissected by numerous tributary streams flowing into the Ohio River. Numerous rock outcrops are exposed along the valley walls (Figure 106). The river flows upon unconsolidated alluvial fill generally, but in numerous places has downcut into underlying bedrock formations of



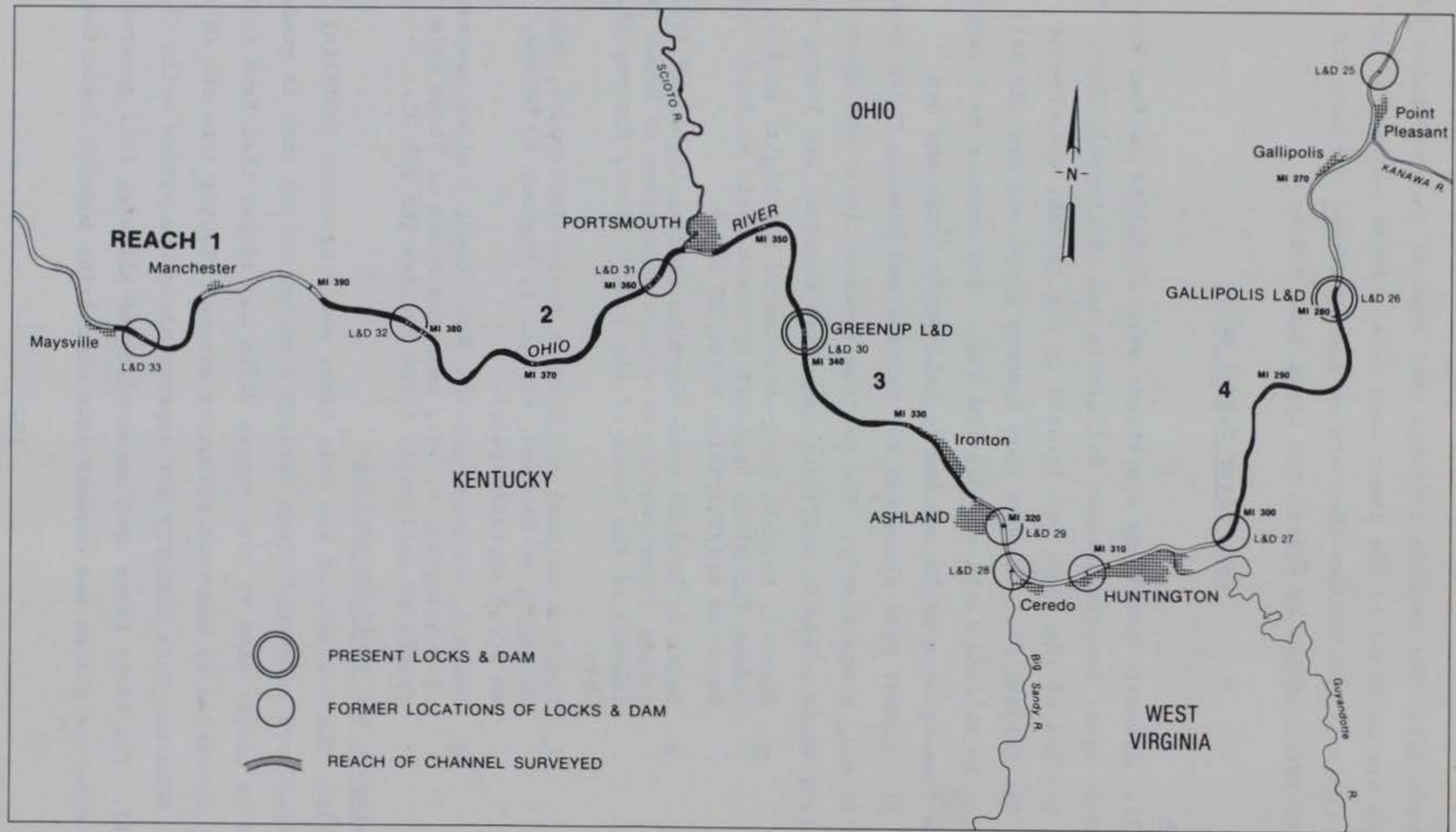

Figure 105. Location map of Ohio River acoustic profiling survey sites





Figure 106. Familiar scene along the Ohio River where the channel has migrated close to its valley wall, rock exposure near RM 116, Kentucky shore

various lithology and age. The valley fill consists predominantly of coarse sands and gravels within a substratum deposit that is veneered by a top stratum composed of silts, clays, and fine sand. The bottom of the present Ohio River channel generally lies below the base of the top-stratum deposits. The fine-grained top-stratum deposits average 10 to 30 ft in thickness (Walker 1957, West Virginia Geological Survey 1956). The fine-grained sediments comprising the top-stratum deposits within the survey area are generally the materials that make up the exposed banks along most of the present Ohio River channel. The material is generally a sandy silt and clay to fine sand with occasional gravel, but the fines are predominant. Although the coarse substratum deposits vary greatly in thickness along the Ohio River with the greater thickness occurring generally in the lower reaches (Walker 1957, West Virginia Geological Survey 1956), available boring data in the survey area indicates



that the substratum deposits probably range from about 10 ft to about 45 ft in thickness.

233. The width of the Ohio River alluvial valley is apparently controlled by the resistance to erosion of the bedrock into which the valley was cut. The width of the valley increases from about 0.7 miles at its upper end near the Pennsylvania-West Virginia state line to about 1.3 miles at Huntington (West Virginia Geological Survey 1956). From Huntington to the western limits of the survey area (RM 414), the widest part of the valley is approximately 2 miles. The average valley width along the length of the survey area is approximately 1 mile.

234. The bedrock valley above Portsmouth, Ohio, rests in rock units of Pennsylvanian age consisting primarily of interbedded sandstones, siltstones, clays, shales, and thin limestones (West Virginia Geological Survey 1956). Below Portsmouth, more-resistant shaly limestone beds of Mississippian and early Paleozoic age are crossed. The relatively narrow, entrenched nature of the Ohio River valley within the area of the survey inhibits the river from developing well-defined meander loops between the valley walls. The gradient of the river is about 1 ft/mile above Ashland, Ky., decreasing to approximately 0.5 ft/mile below Ashland and for the remainder of the survey area.

#### Background of bank erosion problems

235. The locks and dam construction along the Ohio River has resulted in the conversion of the river from a free-flowing stream to a series of low-gradient lakes or pools (Figure 107). The dominant bank erosion mechanisms operating on the Ohio River are believed to be saturation of bank sediments; drawdown; scour of channel sediments at the toe of channel slopes; and other miscellaneous actions such as wind and river traffic-generated waves. Although current velocities are thought to be generally too low for scour of most soils (U. S. Army Engineer District, Pittsburgh 1977), some scouring of coarser sediments may occur during high-water stages along the Ohio River. Erosion of the magnitude and appearance typical of natural, meandering streams, in which a concave bank may erode hundreds of feet over a relatively short period of time, does not normally occur on the Ohio River. Active erosion areas





Figure 107. Characteristically placid setting along the navigation pools of the Ohio River near normal pool elevation

recognized and monitored by CE Districts along the Ohio are characterized principally by sloughing banks of several feet in height retreating a distance of a few feet per year in irregular fashion along straight as well as curved reaches of the river channel.

236. Available data indicates that prior to the late 1920's the Ohio River channel located in the narrower portions of its valley above Hawesville, Ky., was relatively free of serious bank erosion problems. Bank problems now occurring in these reaches above Hawesville may be a response to physical and environmental processes that are associated with changing river regimen, either natural, such as climatic changes, or man-induced, such as forest clearing and cultivation of riparian lands and construction of navigation and flood control structures.

#### Implementation of survey

237. The acoustic profiling survey conducted on the Ohio River was accomplished during the period 20-27 August 1978. The four reaches of the Ohio comprising the surveyed areas of the channel were worked out of Portsmouth, Ohio, and Huntington, W. Va. A general description of the Ohio River acoustic survey is contained in the paragraphs below.



238. Support equipment and personnel. The survey boat, W. E. MERRILL (Figure 108), and operating personnel were furnished by the Pittsburgh Engineer District (PED), CE in support of the acoustic profiling survey. The Huntington Engineer District (HED), CE furnished docking, support facilities, and personnel in support of logistical phases of the acoustic profiling operation.

239. Acoustic survey systems used. A CSRP system, the EG&G Uni-boom, and a side-scanning sonar system, the Klein Hydroscan, were used as primary acoustic data acquisition systems throughout the period of the Ohio River acoustic survey. The EG&G Models 262 and 265 hydrophones were used as receiving components with the Uniboom profiling system.

240. Configuration and characteristics of the survey area. The channel of the Ohio River within the confines of the survey area ranges from about 1000 to 3000 ft in width. For the most part, however, the channel does not exceed 2000 ft in width. The channel generally moves from one side of the valley wall to the other, although the meandering configuration of the channel is rather gentle, not the abrupt, tight meander loops characteristic of some comparably sized streams. The



Figure 108. Survey boat used in support of Ohio River acoustic profiling survey, shown leaving the Greenup Locks and Dam



channel in the survey area is relatively free of both natural and man-made obstacles. The only islands, for instance, of any consequence are the Manchester Islands located near the western limits of the survey area just upstream from Manchester, Ohio, and Brush Creek Island located at about RM 389. Within the survey area there were the remains, or locations, of seven old lock and dam facilities that were demolished and replaced by two new lock and dam facilities (Greenup and Gallipolis). The remains of several of these old structures could be seen on the acoustic profile records, particularly the side-scanning sonar data. Water depths in the survey area generally ranged from about 25 ft to near 60 ft in the thalweg portion of the channel. The average water depth was about 35 ft during the period of the survey. Pool elevations were slightly above normal during most of the survey period in the Meldahl and Greenup navigation pools.

241. Visual observations made of the banks along much of the Meldahl pool below Portsmouth during the survey indicated that actively eroding banks were characterized by a low beachlike, gently sloping foreground extending from the water's edge to the base of a nearly vertical bank from 4 to 20 ft in height (Figure 109). Upright deciduous trees on the beachlike portion of the bank had the soil stripped from their roots (Figure 110) so that in many cases the entire root was exposed. Many trees had fallen (Figure 111). The ordinary high waterline could be seen clearly on the steep portion of the heavily vegetated banks. It was apparent in this reach of the river that the banks had been eroded landward, the soil making up the banks stripped away and carried out into the river, and that the erosion had occurred within the past few years, as some of the large trees were still upright with their roots exposed.

242. The channel bottom in the survey area displayed a rather high degree of variability in profile as observed on the acoustic profile records. Sediment waveforms, i.e., sand waves, were not as evident as have been noted on other large river systems e.g., Missouri and Mississippi Rivers. Only a relatively few reaches of the bottom exhibited sand-wave development and these were generally located in areas



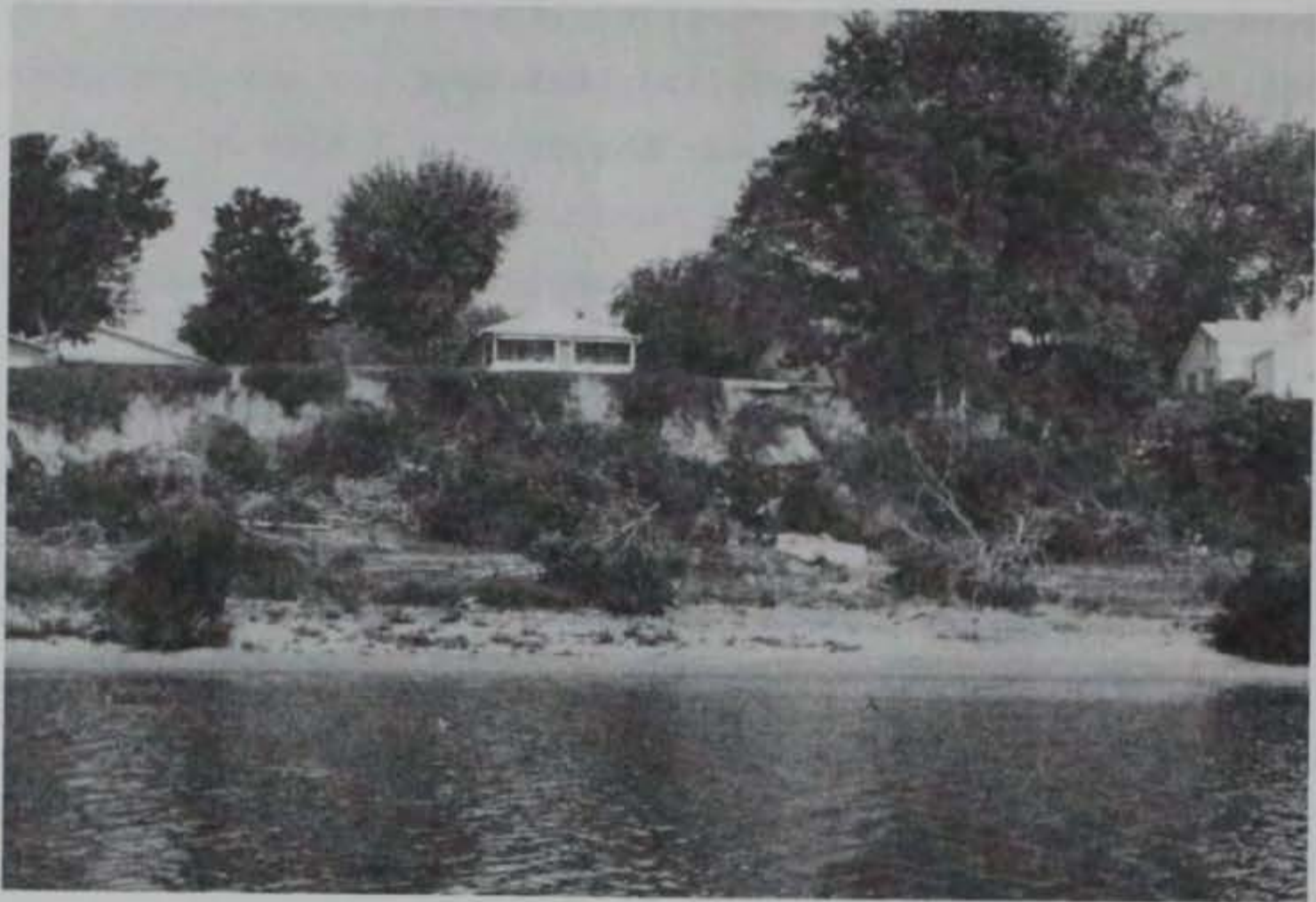

Figure 109. Bank erosion in the Meldahl Navigation Pool; scene representative of numerous reaches where a low, sloping shelf extends to a vertical bank

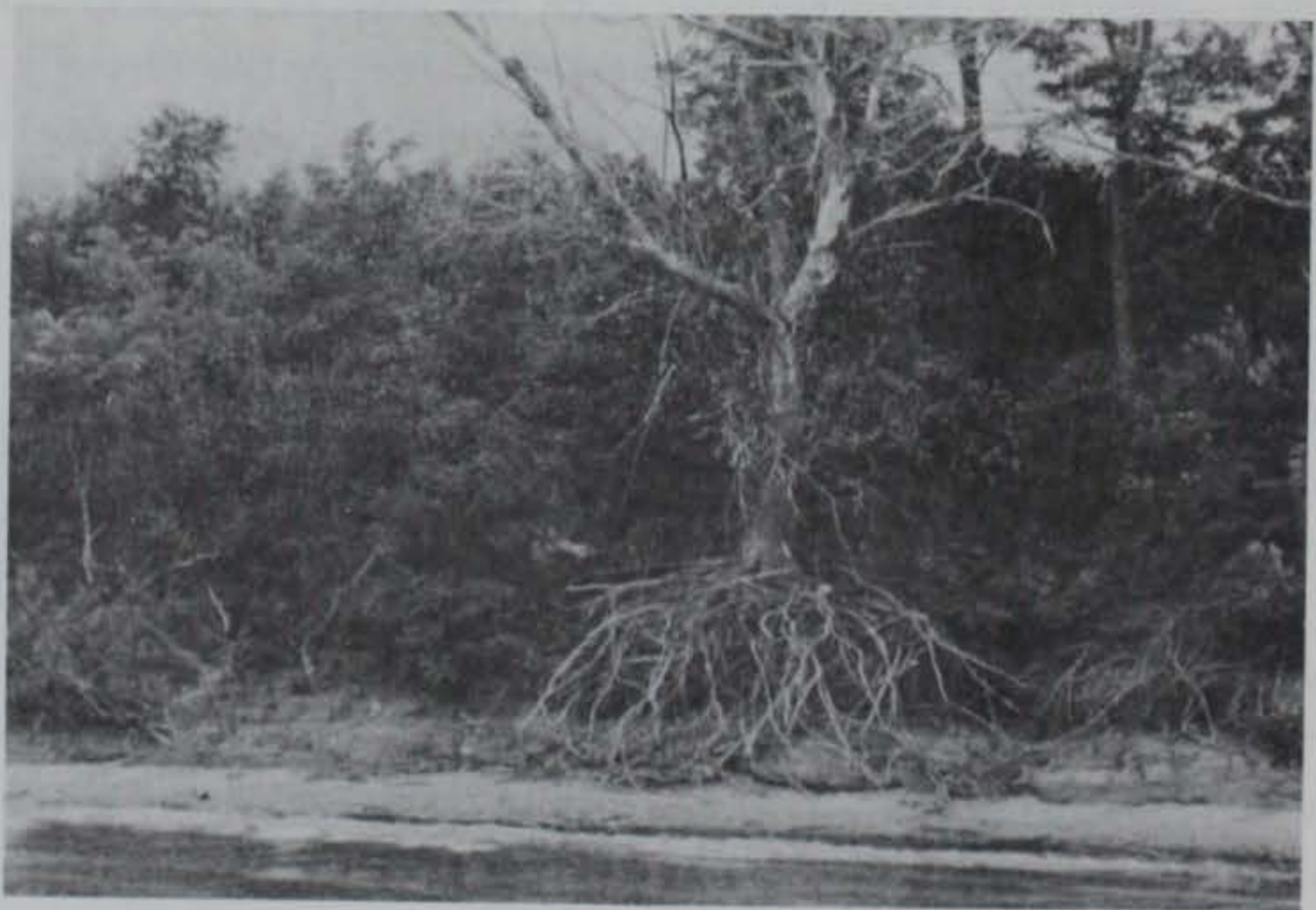

Figure 110. Large deciduous tree deadened by the effect of erosion around its base





Figure 111. Trees along river's edge, toppled by erosion of supporting soil from their root structure

characterized by large shoal deposits. Many areas of the channel bottom were very rough and irregular, suggesting that the bottom in these areas is composed of bedrock. Other reaches of the channel were characterized by a uniformly smooth bottom, exhibiting only minor irregularities interrupting the bottom profile.

243. Availability of background and ground truth data. The following background and ground truth data were available for use during various phases of the Ohio River acoustic survey:

- a. Maps and charts. Topographic maps produced by the USGS at scales of 1:24,000 and 1:250,000 were used during all phases of the Ohio River acoustic survey. The 1:24,000 quadrangles were especially helpful during the actual field survey for orientation and location of the surroundings with that of the survey lines. Geologic mapping at a scale of 1:24,000 in quadrangle format and produced by the USGS was available for nearly all of the survey area along the Kentucky shore. In addition, maps at a scale of 1:24,000 portraying the geology and hydrology of alluvial deposits along the Ohio River were available for portions of the survey area. These maps, produced by the USGS, are contained in special Hydrologic Investigations Atlases and include information such



as top of bedrock contouring, boring logs, and geologic cross sections. Of particular value during the data analysis phase of the Ohio River survey were the hydrographic survey charts produced by the CE in the early 1900's. These charts, extremely rich in map detail, provide information concerning channel configuration and adjacent valley parameters as they were prior to construction of the newer locks and dams and subsequent increase in the elevation of the navigation pools. The charts, at a scale of 1 in. = 600 ft, provide coverage of the Ohio River from Pittsburgh to its mouth.

- b. Soil borings. Boring logs for soil and rock borings drilled in the survey area were obtained for use during the acoustic data analysis from a number of published sources. The majority of the logs were contained in design memorandum published by the CE in conjunction with locks and dam construction along the Ohio River; CE hydrographic survey charts of the type described in preceding paragraphs; and USGS reports of various geologic and hydrologic investigations conducted in the Ohio River valley.

244. Survey procedures. Primarily because of the collective length of the reaches of the Ohio River selected for acoustic surveying, the survey operations generally consisted of running a single, continuous profile line along the channel. The profile line generally followed one side of the channel or the other because it was desirable to monitor the bank line with the side-scanning sonar. In those areas where particularly interesting bottom or subbottom data were obtained, multiple passes were made over the area to acquire greater coverage of the channel bottom/subbottom. Horizontal positioning of the acoustic profile lines was accomplished by event marking the acoustic record as a feature located on maps and charts was passed. Prominent landmarks, i.e., mouths of tributaries entering the river, navigation aids, power and pipeline crossings, etc., were utilized for position fixing. The navigation aids, i.e., radar reflectors, lights, etc., were plentiful and generally of a permanently maintained location located on maps or charts.

245. The side-scanning sonar towfish was towed approximately 10 ft below the water surface off the port side of the bow of the survey boat. The Uniboom source and receiving components were towed on opposite sides



of the boat's wake from each other from the stern of the boat.

246. Data analysis. The overall results of the Ohio River acoustic survey were generally excellent. The quality of boomer and side-scanning sonar data was very good. The essentially slack-water environment of the Ohio River Navigation pools contributed significantly to the high quality of the acoustic records. The characteristically heavy commercial and recreational boat traffic along the Ohio River (Figure 112) resulted in minor problems of spurious data signatures on the records and in alignment of profile lines.

247. CSRP data. The boomer profile in Figure 113 shows river alluvium forming the channel bottom (A). Bedrock (B) underlies the alluvium at an average depth of approximately 10 ft. A scour hole has formed at (C) and has eroded through the sandy alluvial material to the top of the bedrock formation. The scour hole is possibly related to the position of an aerial power line crossing the channel directly above the area of scour. (The vertical line (L) bisecting the scour hole on the acoustic profile was caused by electrical interference from the power



Figure 112. At some sites wave action generated by heavy commercial boat and barge traffic on the Ohio River has been identified as a mechanism for bank erosion



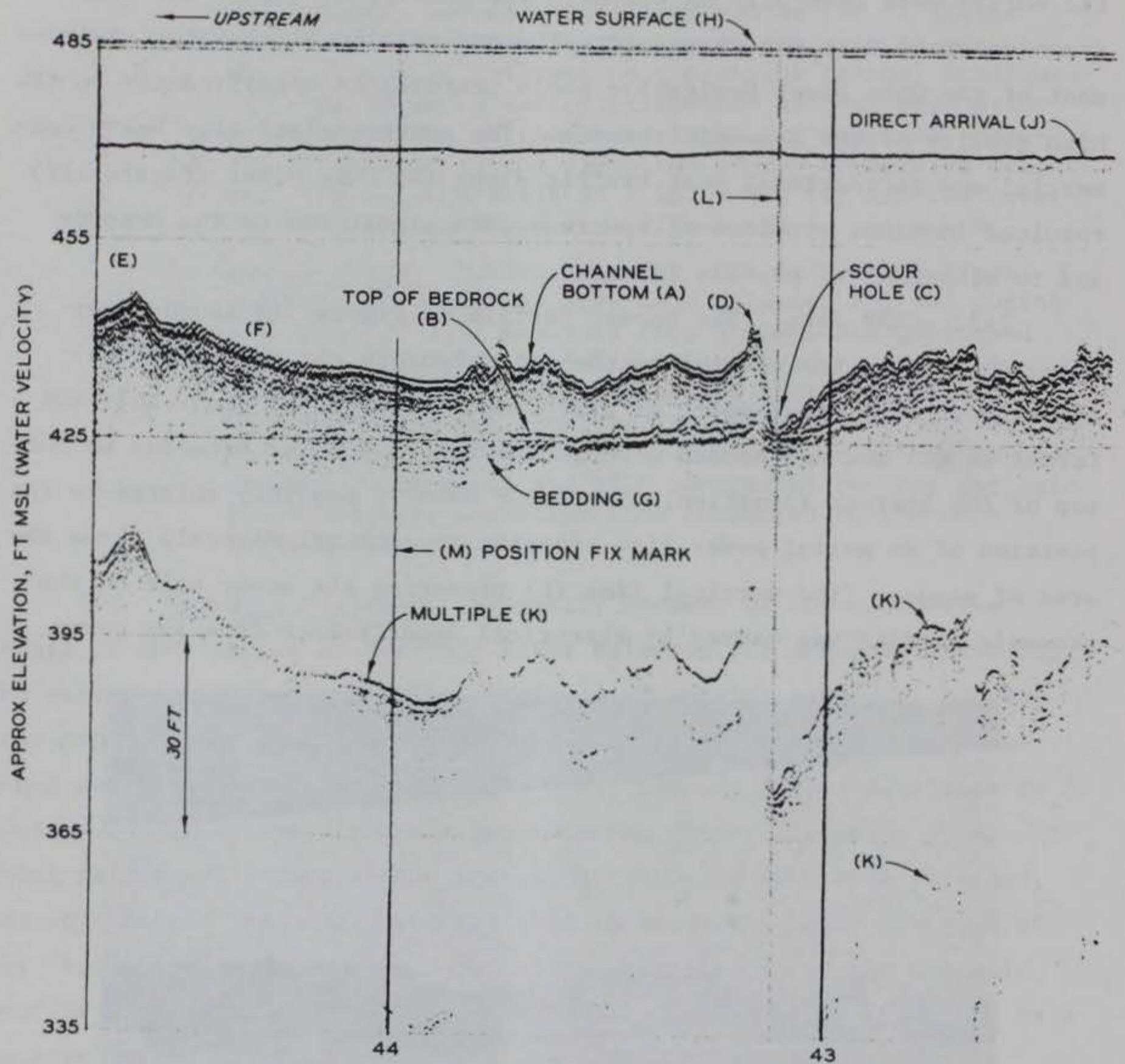

Figure 113. Boomer record in the vicinity of RM 412.6 near Maysville, Ky., Ohio River



line.) The point of scour of the river bed is possibly a result of an object or activity related to the construction of the power line. A shoal is present at (E) where a large creek (Big Three Mile Creek) enters the Ohio River. Small sand waves (F) occur on the bottom just downstream of the shoal. Dipping beds can be seen in the bedrock formation at (G). The highly irregular nature of the channel bottom, both upstream and downstream of the scour hole, may be due to detached pieces of rock from the bluffs above the right bank of the channel in this area. The water surface is at (H), the direct arrival at (J), multiple reflections at (K), and position fix marks at (M). The horizontal scale of the profile is 1 in. = 200 ft approximately.

248. Figure 114 illustrates the development of sand waves (A) on the channel bottom. The reflector below the sand waves is probably the top of bedrock (B). The bedrock outcrops and forms the channel bottom downstream of the area of sand wave development. The water surface is at (C), the direct arrival at (D), multiple reflections at (E), and position fix mark at (F). The horizontal scale of the profile is 1 in. = approximately 200 ft.

249. The profile in Figure 115 shows a large shoal feature developing at the confluence of two creeks with the Ohio River. The shoal begins at (A) and is developing in a downstream direction. The former position of the Ohio River channel bottom in the shoal area is delineated by the reflector (B). The downstream migration of sediments from the mouths of the creeks is evident along the right portion of the profile. The maximum depth of the shoal deposit as measured on the profile is about 11 ft. The present channel bottom is at (C), the water surface is at (D), direct arrival at (E), multiple reflections at (F), and position fix marks at (G). The horizontal scale of the profile is 1 in. = approximately 200 ft.

250. The profile in Figure 116 starts along the point bar side of the channel, crosses the channel, and approaches the steep bedrock valley wall to the right side of the profile. The top of the bedrock is interpreted as being at (A). Note that the bedrock surface increases in elevation as the valley wall is approached. The modern Ohio River



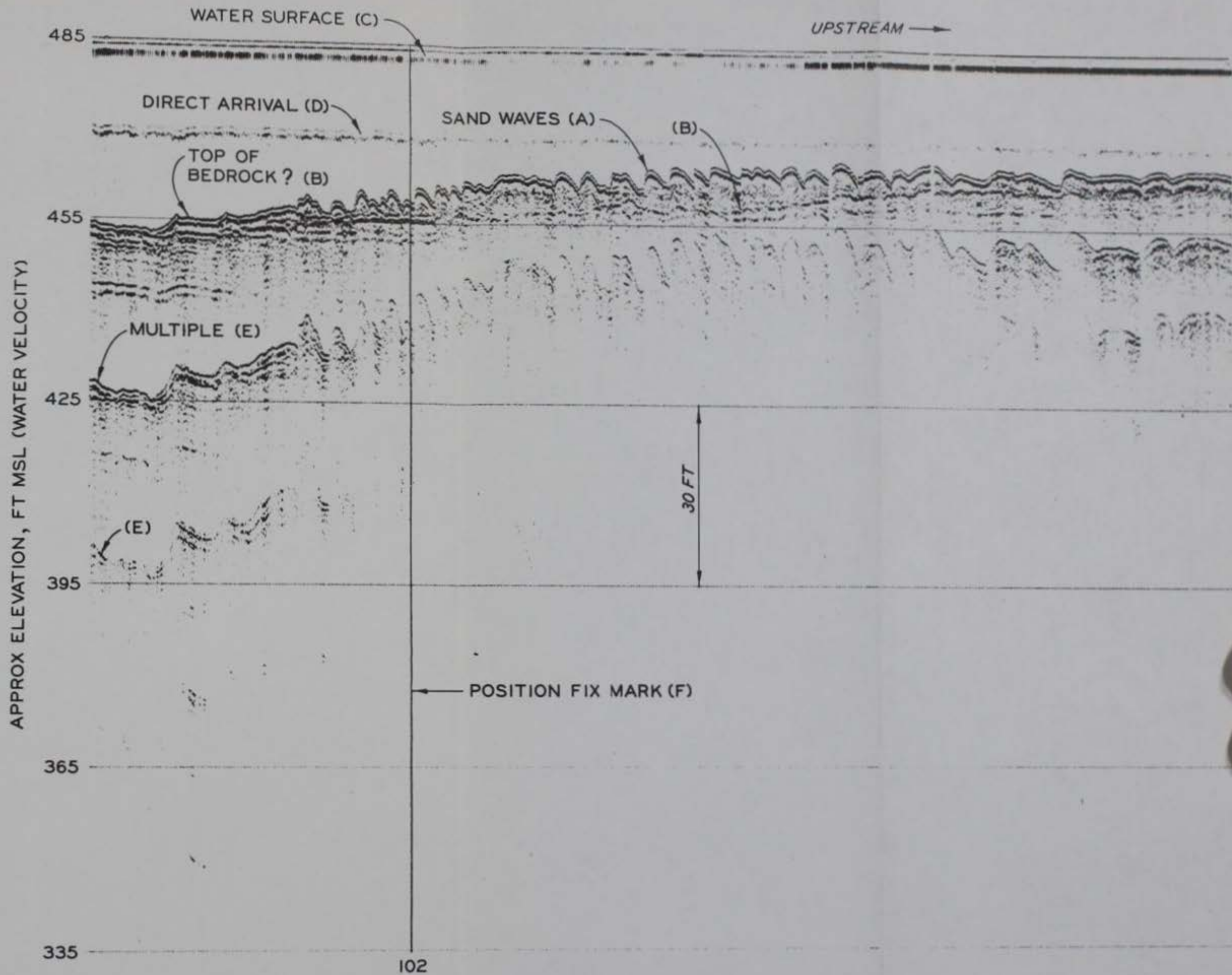

Figure 114. Boomer record, Ohio River at Portsmouth, Ohio, located between RM 354 and 355



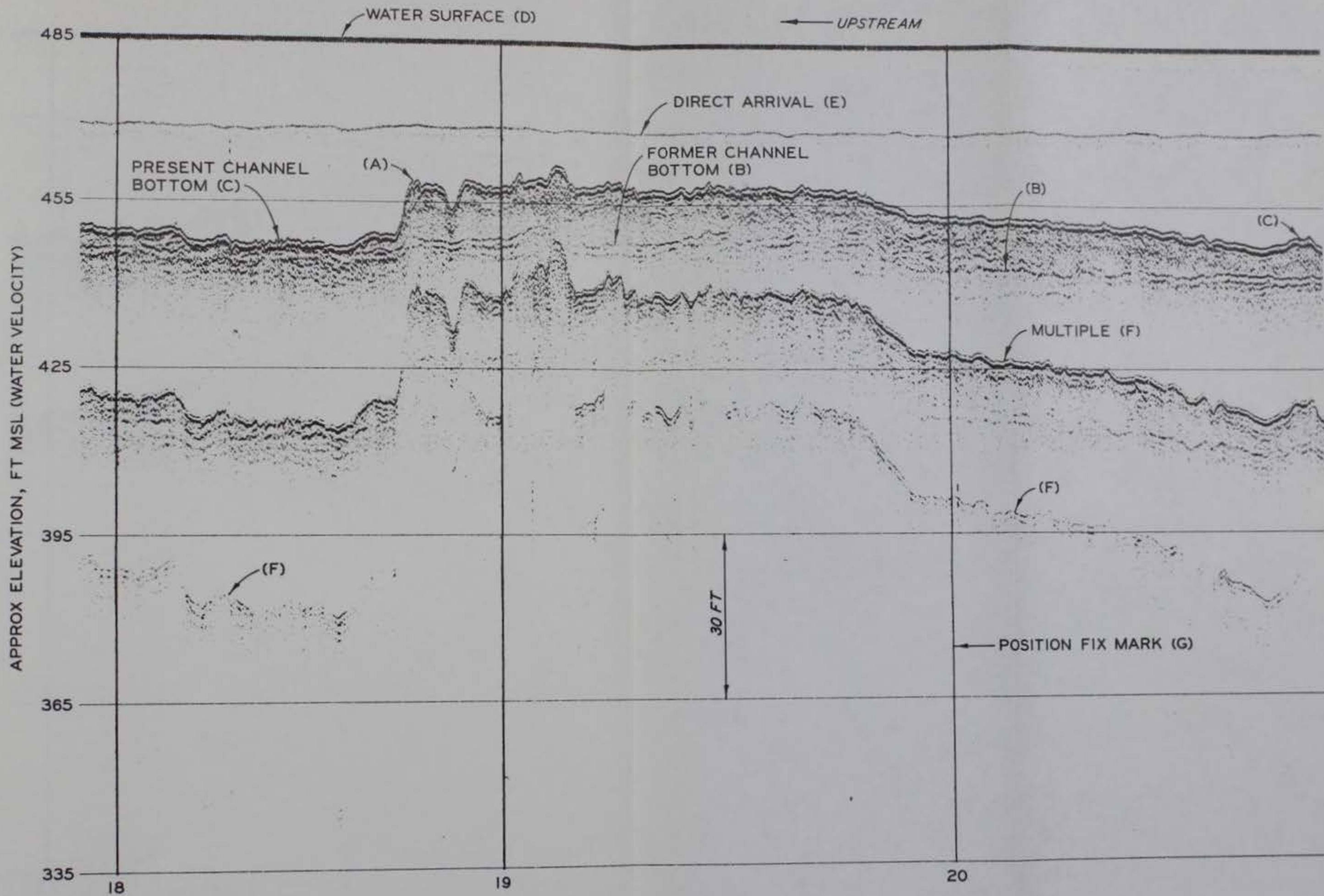

Figure 115. Boomer record, Ohio River at Buena Vista, Ohio, RM 373 to RM 374



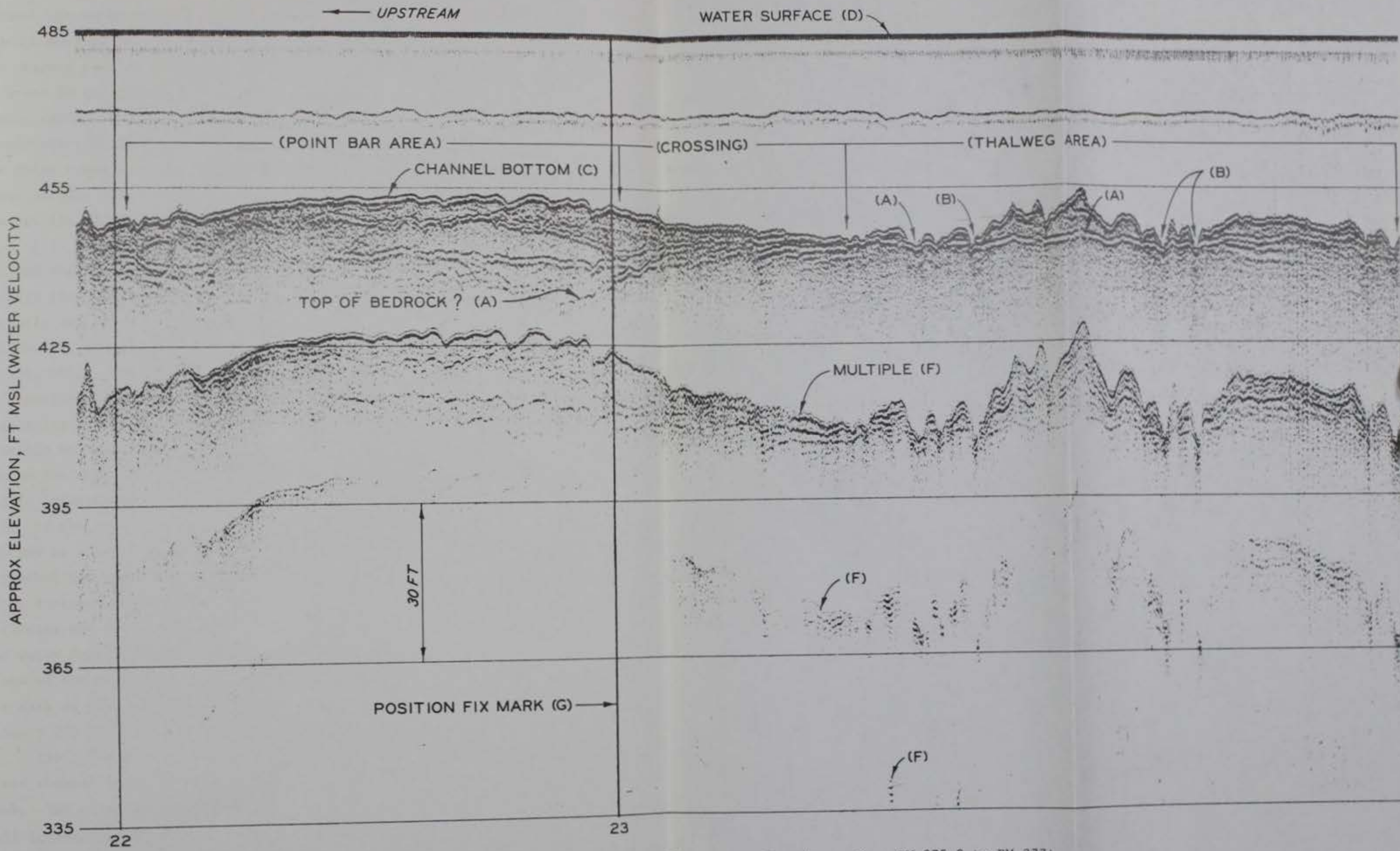

Figure 116. Boomer record, Ohio River, near Vanceburg, Ky., RM 375.9 to RM 377+



channel has apparently incised the overlying alluvium and cut into the bedrock surface at (B), creating a rough, irregular channel bottom in the thalweg portion of the channel. Several subbottom reflectors are apparent in the point bar area in the left portion of the profile, indicating various stages of the lateral migration of the point bar in the floodplain portion of the river valley. The channel bottom is at (C), the water surface at (D), the direct arrival at (E), multiple reflections at (F), and position fix marks at (G). The horizontal scale of the profile is 1 in. = approximately 200 ft.

251. The profile (Figure 117) shows interpreted bedrock surfaces (A) and possibly (C) dropping away from the channel bottom (B) as the profile line leaves the steep bedrock valley wall which terminates abruptly at its intersection with the small floodplain of Eagle Creek, a tributary stream entering the Ohio River about 1.5 miles south of Ripley, Ohio. The reflector (A) outcrops at the channel bottom in the left portion of the profile. The channel bottom here is very rough, suggesting that the reflector (A) is either rock or a semiindurated gravelly deposit (older substratum sands and gravel?). The channel bottom to the right of the outcropping (A) horizon is relatively smooth and is interpreted as alluvial silts and sands overlying the reflector (A). If the reflector (A) is indeed the bedrock surface, reflector (C) may be a major bedding plane within the rock formation, or it may represent the eroded surface of an older alluvial deposit. Borings a short distance downstream in a point bar deposit suggest that the (A) reflector may be the surface of a gravelly deposit, rather than bedrock. The water surface is at (D), the direct arrival at (E), multiple reflections of the channel bottom and subbottom reflectors at (F), and position fix mark at (G). The horizontal scale of the profile is approximately 1 in. = 200 ft.

252. The profile in Figure 118 is a cross section of the Ohio River channel from near the Ohio bank to a point close to the Kentucky bank. The right margin of the profile is near the steep bedrock valley wall located on the Ohio shore. The bottom of the channel (C) is composed of rock near the Ohio shore. Note the intense and numerous



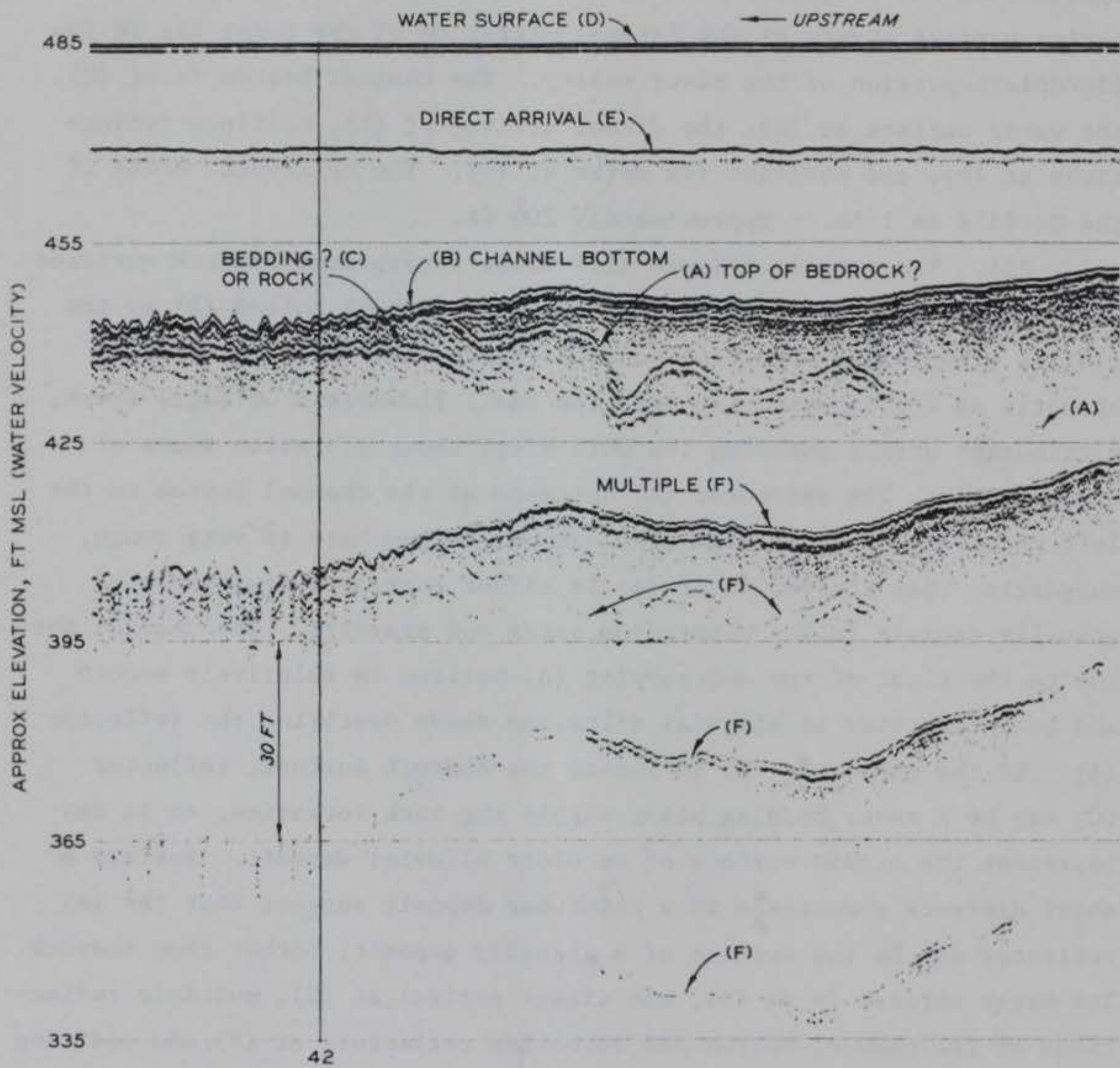

Figure 117. Boomer record, Ohio River, in the vicinity of RM 414, downstream of Maysville, Ky.



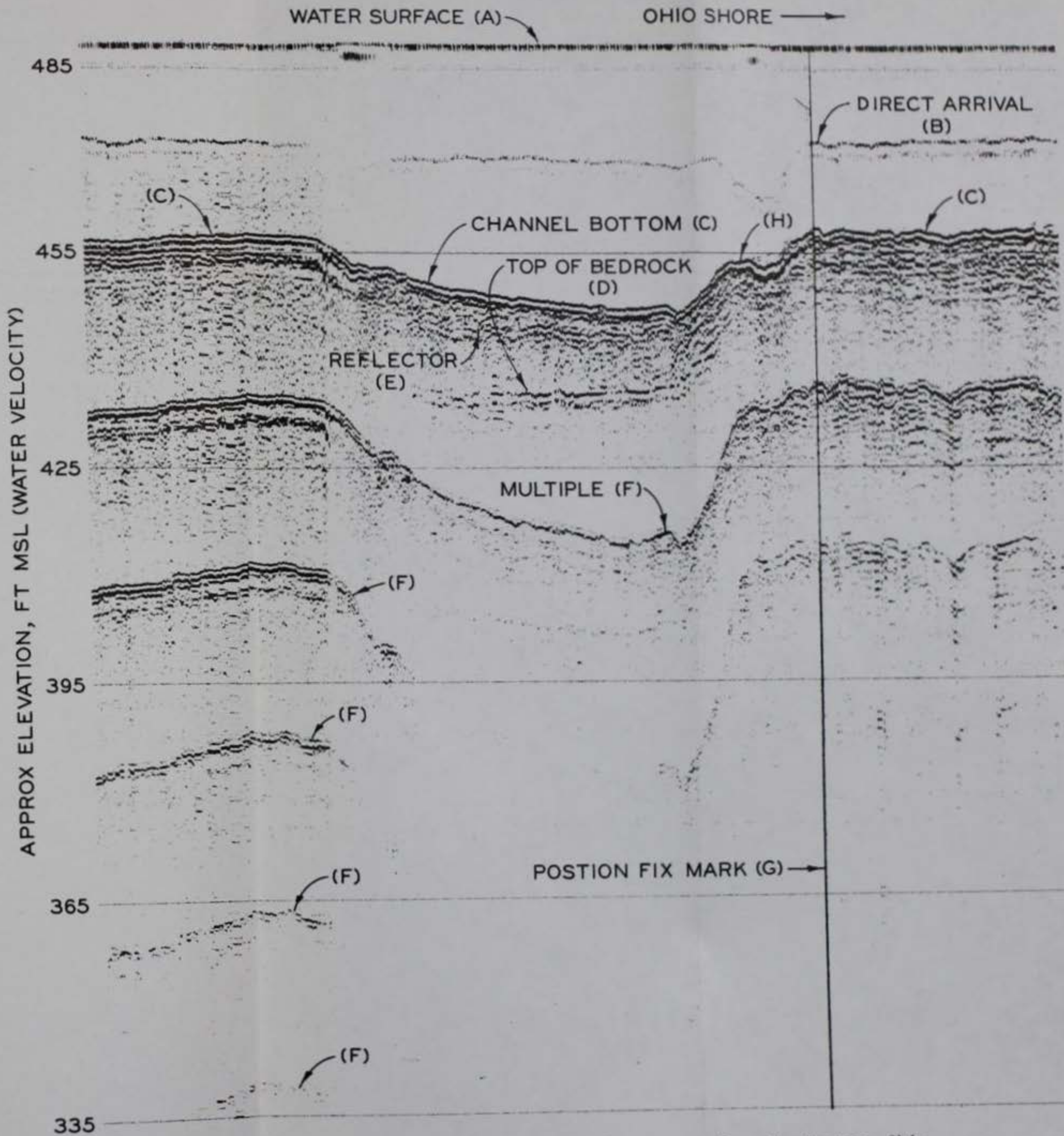

Figure 118. Boomer record, Ohio River, RM 394, upstream from Manchester, Ohio



multiple reflections of the channel bottom. As the profile progresses southward toward the Kentucky shore, it reaches the older position of the Ohio River channel that was occupied by the river prior to construction of the new locks and dams. At this point, the present channel bottom and the bedrock abruptly drops in elevation. The bedrock (D) dips below the channel bottom and continues southward. The top of rock (D) can be traced several hundred feet before it gets too deep to detect. The bench feature (H) is a common feature along the periphery of the older channel alignment. It is apparently an erosional feature developed over a long period of time by fluctuations in Ohio River stage. The reflector (E) located below the present bottom and restricted generally to the area of the older channel may represent the top of coarse substratum alluvium. The profile continues into a point bar area in the left portion of the record where the smooth bottom is representative of silty and sandy alluvium. The bedrock valley wall bordering the alluvial valley along the Kentucky shore is approximately one-half mile south of the present position of the bank line. The bedrock reflector (D) probably rises abruptly just before reaching the valley wall. The surface of the water is at (A), direct arrival at (B), multiples at (F), and position fix mark at (G). The horizontal scale of the profile is 1 in. = approximately 200 ft.

253. Side-scanning sonar data. Features interpreted as large subaqueous slumps (A) extending from near the toe of the right bank (B) are the most prominent features on this profile record in Figure 119. The slump material has accumulated at the bottom of the bank slope where it displays a hummocky appearance where the bottom profiles (C) intersect the features. The herringbone pattern (D) is a noise interference pattern caused by a passing towboat. The dot and dash pattern (F) is interference from a boomer CSRP system used concurrently with the side-scanning sonar system. The toe of the left bank slope is at (E). Anomalous bottom targets are located at (G). The horizontal scale of the record is 1 in. = approximately 200 ft.

254. Figure 120 shows the remains of old Lock and Dam 30 which was replaced by a new lock and dam a short distance downstream from the



old site (Greenup Locks and Dam). Lock and Dam 30 was constructed in the early 1920's and was abandoned in the 1960's. Most of the concrete structures were left intact because they were of sufficient depths below the new pool elevation so as to pose no danger to navigation. Circular structures constructed of metal and/or concrete, such as the old mooring cells (A) for Lock and Dam 30, characteristically produce intense reflection signatures in the form of hyperbolas. The inner (B) and outer (C) lock walls provide strong linear reflection signatures. These structures appear curvy because of variations in the horizontal distance from the towfish to the structures. The old dam can be seen at (D) where the bottom profile intersects it. The closely spaced linear pattern at (E) may be concrete steps, or an artificially terraced slope, which extends from a concrete esplanade (G) to an upper level of the installation. The lower portion of the feature (F) appears to have been silted over. The light tones and smooth texture displayed by the areas occupied by the esplanade (G) and linear pattern (F) may be due to the deposition of predominantly fine alluvium, e.g., silt and clay, in the areas of higher elevations. Note the difference in the tone and texture of the (G) area as opposed to the (J) area of the channel bottom. The tonal and textural characteristics of the (J) area suggest that the channel bottom in this area is composed of predominantly coarse grain sediments. The channel bottom profile is at (H), and position fix marks at (I). The horizontal scale of the record is 1 in. = approximately 200 ft.

255. The unusual looking features (A) located on the channel bottom in this record (Figure 121) are interpreted as being subaqueous slumping occurring along the lower bank of the channel near the valley wall. The channel bottom is (B). The unusual configuration and pattern of these slumps may be due to the presence of structural controls in bedrock located at very shallow depths in this reach of the river. The herringbone pattern (D) is noise interference from a passing boat. The toe of the right bank is located at (C). The horizontal scale of the record is 1 in. = approximately 200 ft.

256. The record contained in Figure 122 shows a segment of the lower channel bank that exhibits a high degree of instability. The



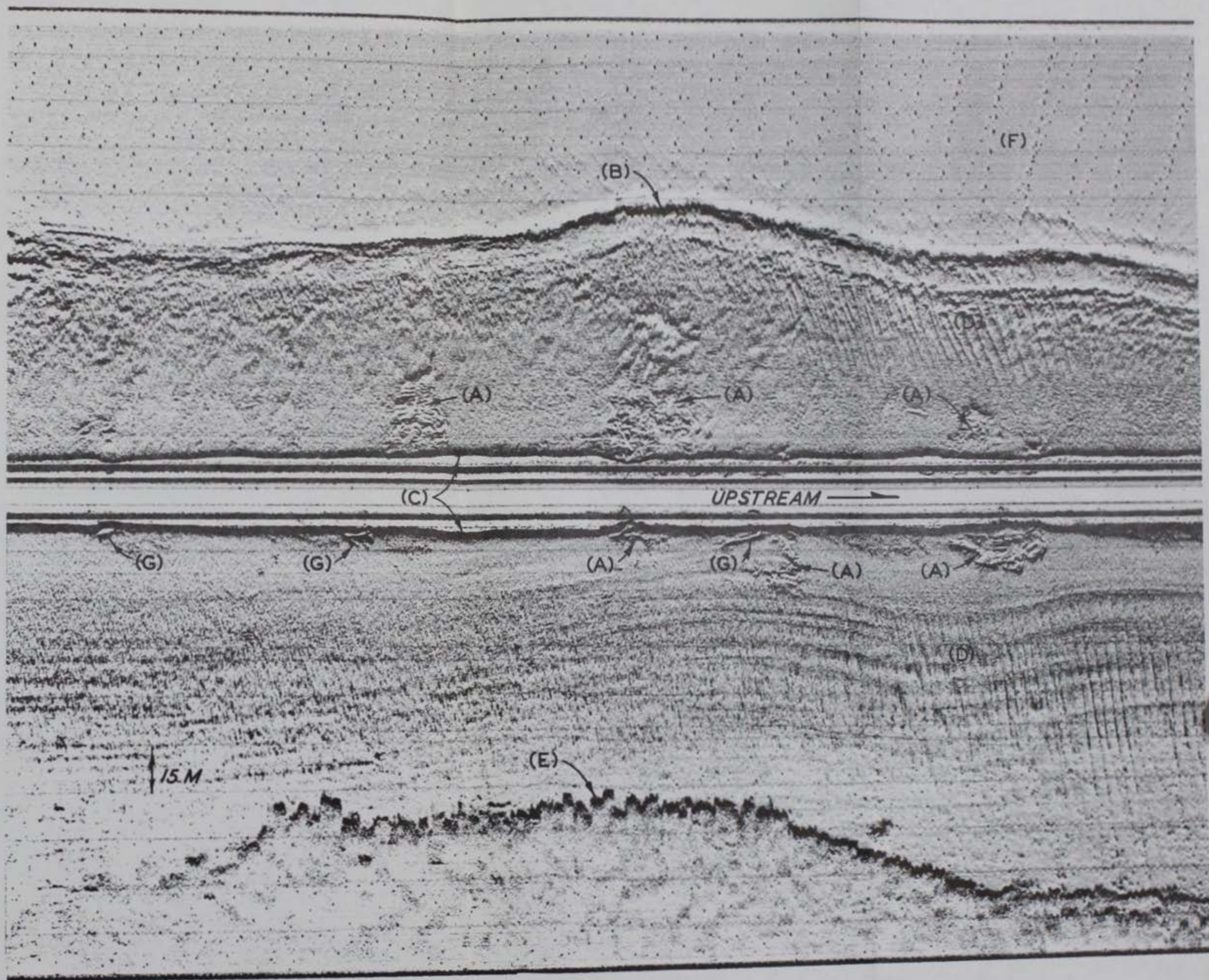

Figure 119. Side-scanning sonar record, Ohio River, in the vicinity of RM 375 near Vanceburg, Ky.



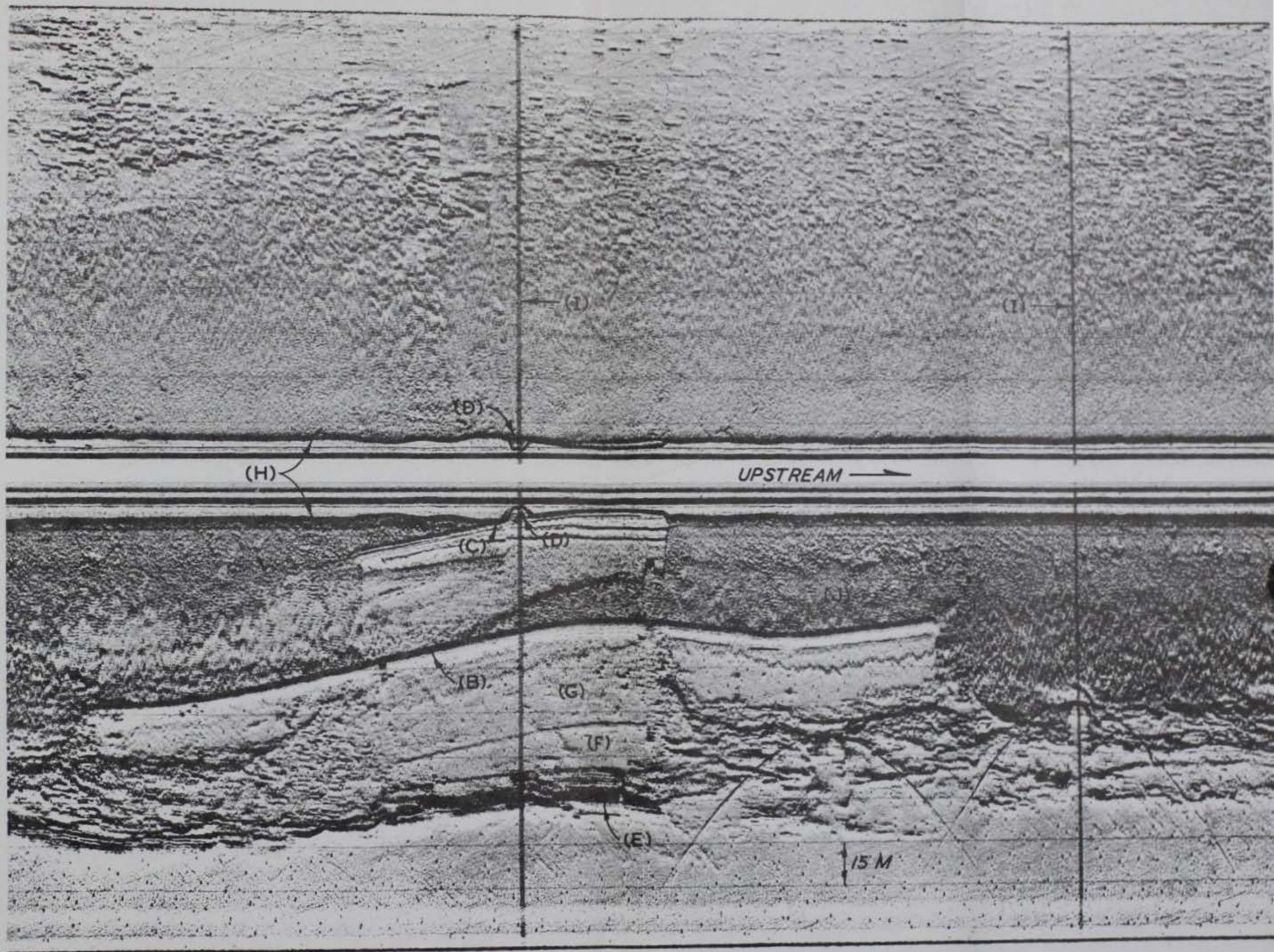

Figure 120. Side-scanning sonar record, Ohio River, at old Lock and Dam 30, RM 338, near Greenup, Ky.



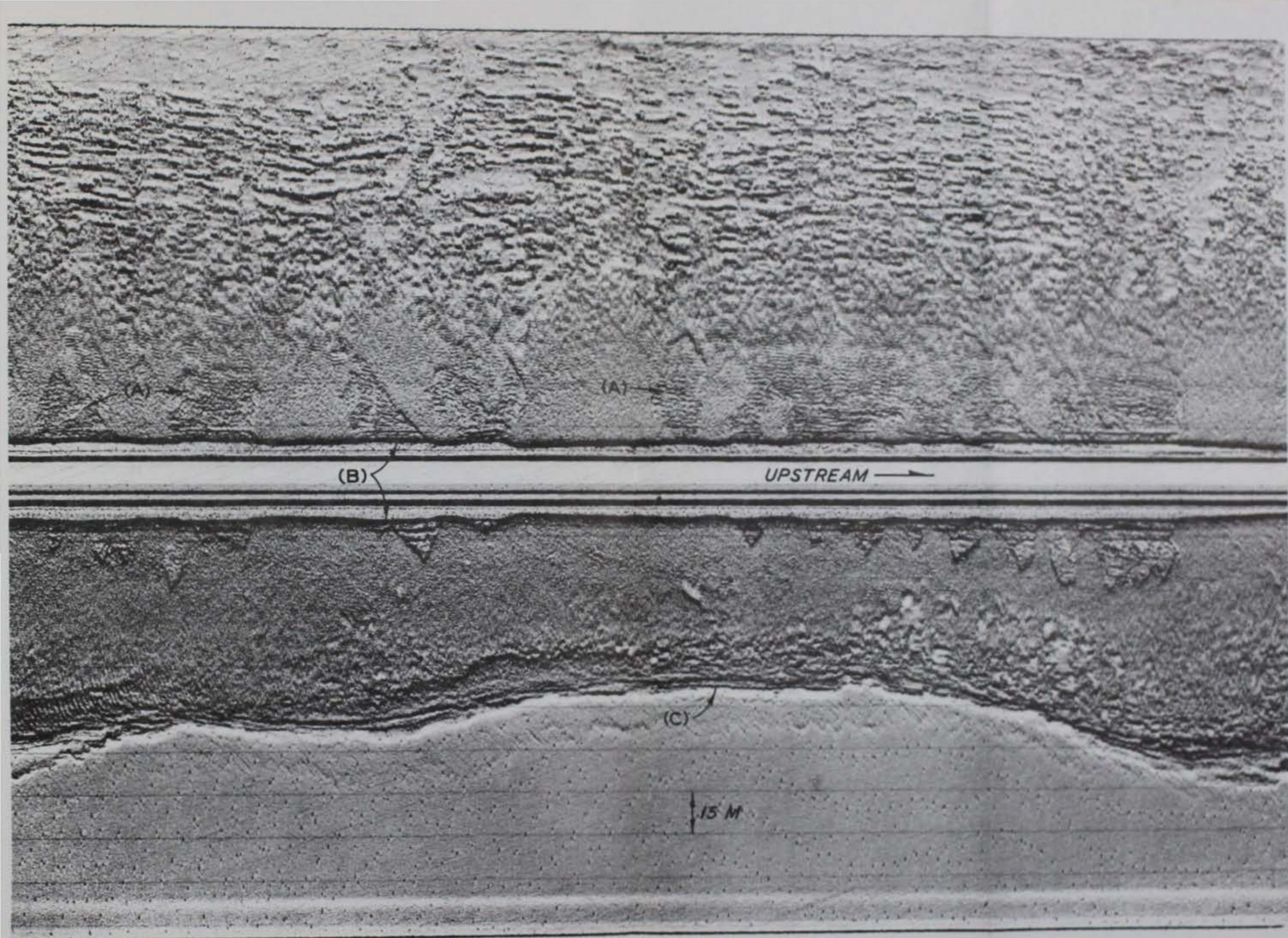

Figure 121. Side-scanning sonar record, Ohio River, between RM 337 and 338, near Greenup, Ky.



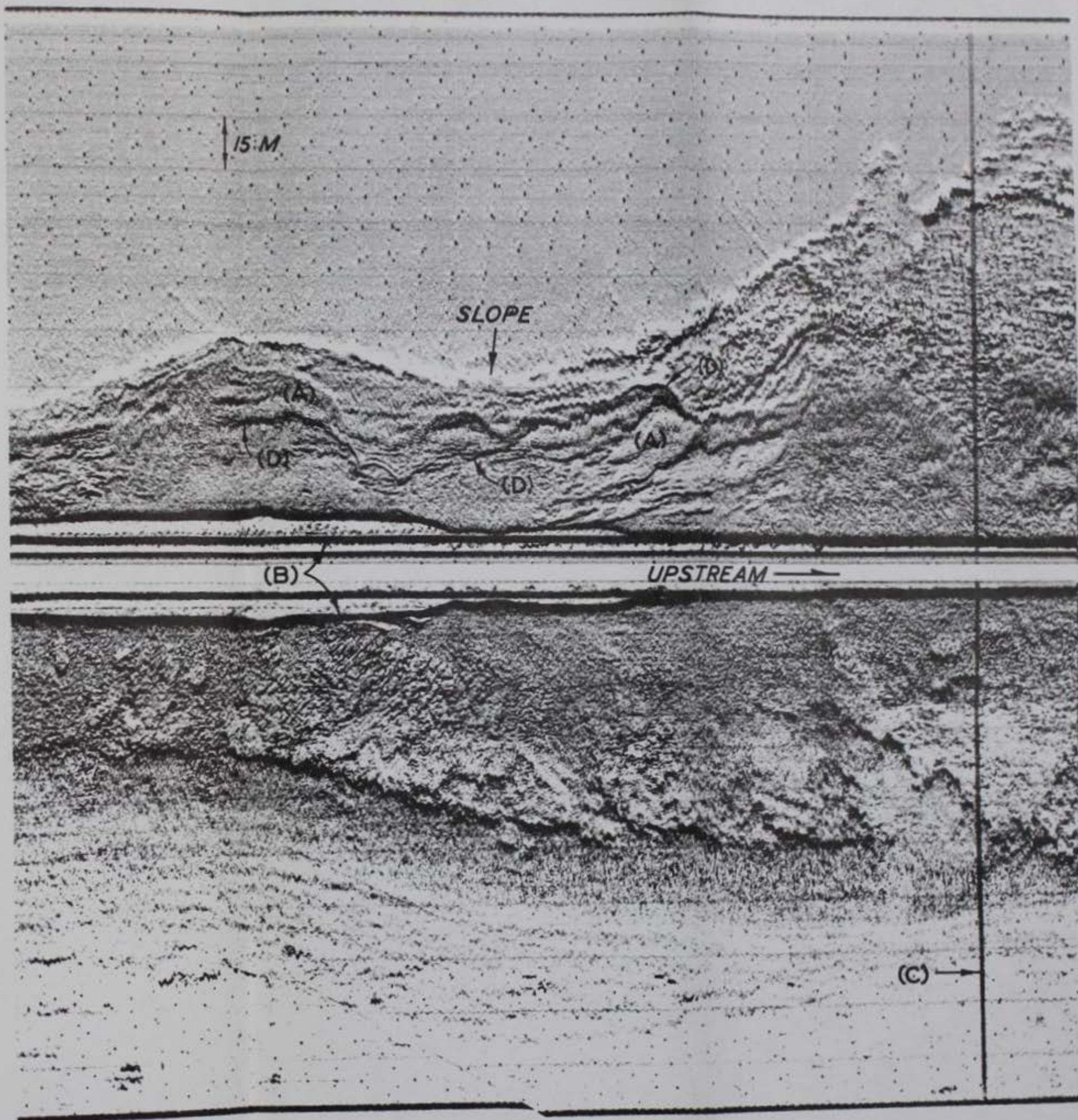

Figure 122. Side-scanning sonar record, Ohio River, in the vicinity of RM 375



areas (A) are characterized by a chaotic appearance resulting from areas of irregular hummocky surfaces and well-defined scarps (D). The movement of material is downslope with the leading edges of the mass bounded by arcuate scarps (D). The hummocky appearance of the failed material can be noted at those points where the bottom profile (B) crosses the affected area. A position fix mark is at (C). The horizontal scale of the record is 1 in. = approximately 200 ft.

#### Results of survey

257. Subaqueous slumping detected by the acoustic survey systems during the Ohio River survey appear to be: (a) located primarily on the lower bank portion of the Ohio channel, and (b) related to deep-seated failures of the bank. The CSRP system revealed that the channel has incised into underlying bedrock in numerous reaches of the river and that the rock probably imposes significant limitations on channel degradational processes.



## PART V: CONCLUSIONS AND RECOMMENDATIONS

### Conclusions

258. It was established that the state of the art of waterborne geophysical systems is sufficiently developed for application to Corps of Engineers mission projects. Waterborne geophysical techniques were found to be particularly applicable, appropriate, and useful in the fluvial environment and provide information necessary for streambank erosion studies as well as for other river engineering investigations.

259. The data derived from waterborne geophysical studies is applicable to planning, design, construction, and monitoring of channel stabilization, navigational, and other hydraulic structures.

260. These techniques, although providing meaningful information when used alone, are most successfully applied in conjunction with related geologic, hydrologic, and hydraulic investigations. Similar to land geophysical studies, waterborne geophysical data should be correlated with data derived from borings or bottom sampling.

261. The principal applications of waterborne geophysics pertain to acoustic profiling techniques which provide data on channel subbottom conditions and which map the configurations of the channel bottom and adjacent bank slopes.

262. The continuous seismic reflection profiling technique provides for the detection and identification of stratigraphic and structural geology, and, to a limited extent, lithologic features on and below the bottom of the channel. The technique is particularly useful for locating and distinguishing between alluvial sediments and rock along the profile traverses. Sand waves and other topographic features can also be identified.

263. The overall surface configuration of the channel bottom can be determined by side-scanning sonar. This system detects, and generally delineates, both natural and man-made features and objects which are situated on the channel bottom. Natural features such as sand waves, rock outcrops, scour holes, and subaqueous bank failure zones; man-made



objects such as channel-control dikes and revetments; sunken barges and boats; pipelines; and miscellaneous debris can be detected and identified with the side-scanning sonar system.

264. Waterborne geophysical surveys can contribute significantly to streambank erosion studies, including design and performance monitoring, by providing general information and site-specific information. General information is that data which may be applicable to any river engineering endeavor and may include water depths, channel bottom configuration, nature and location of channel material, and features such as debris, rock, sediment distribution, and geologic structures. Specific information includes identification of top of bedrock, submerged bank failure zones, faulting, sediment-rock interfaces, scour holes, boat wrecks, and dike and revetment conditions.

265. The location of a channel and the location of bank erosion may be controlled by the occurrence of bedrock along the sides and on, or below, the bottom of the channel. Continuous seismic reflection profiling determines the occurrence, depth, and distribution of bedrock and thereby contributes to the determination of those reaches of the channel most susceptible to erosion. This information can be used for design and location of bank protection structures and other channel stability studies.

266. Side-scanning sonar surveys provide specific information pertinent to erosion studies by locating underwater failure zones. Thus, the toes of slides or slumps involving channel banks may be detected on channel bottoms or near the bottom on the bank slopes. Underwater failure associated with bank protection paving and revetments may also be detected with the side-scanning sonar system. The detection of underwater failure zones indicates deep-seated failure and suggests the need for low or total bank protection.

267. Continuous seismic reflection profiling and side-scanning sonar techniques can be most successfully applied for periodic routine or special purpose monitoring. The data acquired for each period, or survey, can be compared and changes or trends in channel conditions can be identified. Such periodic monitoring can be particularly significant



where identified streambank erosion, underwater bank failures, or other adverse fluvial conditions may be occurring.

268. The restraints on the application of waterborne geophysical techniques include environmental factors such as water depth, weather conditions, turbulence, and water surface roughness. Physical and acoustical properties of bottom and subbottom sediments are directly related to the performance of waterborne geophysical systems. The depth of subbottom penetration by continuous seismic reflection profiling systems are limited by the operational frequencies at which they are designed to be operated. Data interpretation restraints pertain to the skill and experience of the interpreter and to the availability of ground truth data.

#### Recommendations

269. Waterborne geophysical techniques should be used routinely for the acquisition of data for the planning, design, construction, and maintenance of channel stabilization and hydraulic structures, navigational pools, and channel-control projects.

270. These techniques should be used for the periodic and routine monitoring of river reaches, particularly those which are unstable.



## REFERENCES

- Burchett, R. R. 1965. "Correlation of Formations Drilled in Test Holes for Interstate 480 Bridge between Omaha, NE, and Council Bluffs, IA," Nebraska Geological Survey, Paper 17, University of Nebraska, Lincoln, Nebr.
- Cawley, J. 1965. "Review of Marine Navigation Systems and Techniques," U. S. Department of the Navy, Bureau of Ships.
- Office, Chief of Engineers. 1969. "A Study of Streambank Erosion in the United States," Committee on Public Works, House of Representatives, 91st Congress, 1st Session, U. S. Government Printing Office, Washington, D. C.
- Clay, C. S. and Medwin, H. 1977. Acoustical Oceanography: Principles and Applications, Wiley-Interscience, New York.
- EG&G, Inc. No date. "Side-Scan Sonar: A Comprehensive Presentation," Waltham, Mass.
- Ferguson, H. B. 1940. History of the Improvement of the Lower Mississippi River for Flood Control and Navigation, 1932-1939, Mississippi River Commission, Vicksburg, Miss.
- Guy, H. P. and Norman, V. W. 1970. "Field Methods for Measurement of Fluvial Sediment," Techniques of Water-Resources Investigations of the United States Geological Survey, Book 3, Chapter C2, U. S. Government Printing Office, Washington, D. C.
- Hamilton, E. L. 1972. "Compressional-Wave Attenuation in Marine Sediments," Geophysics, Vol 37, No. 4, pp 620-646.
- Hart, E. D. and Downing, G. C. 1977. "Positioning Techniques and Equipment for U. S. Army Corps of Engineers Hydrographic Surveys," Technical Report H-77-10, U. S. Army Engineer Waterways Experiment Station, Vicksburg, Miss.
- Jenkinson, W. D. 1977. "Side-Scan Sonar: Applications in Oil Exploration and Exploitation," Oil and Gas Journal, Petroleum Publishing Company.
- Kolb, C. R. et al. 1968. "Geological Investigation of the Yazoo Basin, Lower Mississippi Valley," Technical Report No. 3-480, U. S. Army Engineer Waterways Experiment Station, Vicksburg, Miss.
- Lowell, F. C. and Dalton, W. L. 1971. "Development and Test of a State-of-the-Art Subbottom Profiler for Offshore Use," Proceedings: Offshore Technology Conference, 1971, Houston, Tex.
- Miller, R. D. 1964. "Geology of the Omaha-Council Bluffs Area Nebraska-Iowa," Geological Survey Professional Paper 472, U. S. Government Printing Office, Washington, D. C.
- Munger, P. R. et al. 1976. "LMVD Potamology Study (T-1)," The University of Missouri-Rolla, Rolla, Mo., prepared for the Department of the Army, St. Louis District, CE.



- Saucier, R. T. 1970. "Acoustic Subbottom Profiling Systems: A State of the Art Survey," Technical Report S-70-1, U. S. Army Engineer Waterways Experiment Station, Vicksburg, Miss.
- Saucier, R. T. and Smith, F. L. 1971. "Geological Investigation of the Western Lowlands Area, Lower Mississippi Valley," Technical Report No. S-71-5, U. S. Army Engineer Waterways Experiment Station, Vicksburg, Miss.
- Smith, D. T. and Li, W. N. 1966. "Echo-Sounding and Sea-Floor Sediments," Marine Geology, Vol 4, pp 353-364.
- Smith, L. M. and Patrick, D. M. 1979. "Engineering Geology and Geomorphology of Streambank Erosion; Report 1, Eel River Basin, California," Technical Report GL-79-7, U. S. Army Engineer Waterways Experiment Station, Vicksburg, Miss.
- Stephens, R. W. B., ed. 1970. Underwater Acoustics, Wiley-Interscience, New York.
- Tullos, F. N. and Reid, A. C. 1969. "Seismic Attenuation of Gulf Coast Sediments," Geophysics, Vol 34, No. 4, pp 516-528.
- U. S. Army Engineer District, Omaha. 1971. "The Missouri River in the 70's," U. S. Army Corps of Engineers, Omaha, Nebr.
- U. S. Army Engineer District, Pittsburgh. 1977. "Metro Wheeling Urban Study, West Virginia and Ohio," U. S. Army Corps of Engineers, Pittsburgh, Pa.
- U. S. Army Engineer District, St. Louis. 1964. "Kaskaskia River, Illinois Navigation Improvement," Design Memorandum No. 1A, U. S. Army Corps of Engineers, St. Louis, Mo.
- U. S. Army Engineer Waterways Experiment Station. 1980. "Waterborne Seismics in Engineering Geologic Investigations," Vicksburg, Miss.
- Walker, Eugene H. 1957. "The Deep Channel and Alluvial Deposits of the Ohio Valley in Kentucky," U. S. Geological Survey Water Supply Paper 1411.
- West Virginia Geological Survey. 1956. "Geology and Economic Resources of the Ohio Valley in West Virginia," Vol XXII.
- Whitten, C. B. and Patrick, D. M. 1981. "Engineering Geology and Geomorphology of Streambank Erosion; Report 2, The Yazoo Basin Uplands, Mississippi," Technical Report GL-79-7, U. S. Army Engineer Waterways Experiment Station, Vicksburg, Miss.
- Winkley, B. R. 1977. "Man-made Cutoffs on the Lower Mississippi River, Conception, Construction, and River Response," Report 300-2, U. S. Army Engineer District, Vicksburg, CE, Vicksburg, Miss.



## BIBLIOGRAPHY

- Bitting, K. R. 1972. "Mooring Site Survey Equipment," Report 2035, U. S. Army Mobility Equipment Research and Development Center, Ft. Belvoir, Va.
- Bowers, R. 1963. "Modern Methods of Subbottom Profiling Using Sonic Reflection Techniques," Science Progress, Vol 51, No. 201, pp 80-84.
- Buchan, S., et al. 1972. "Relations Between the Acoustic and Geotechnical Properties of Marine Sediments," Journal of Engineering Geology, Vol 5, pp 265-284.
- EG&G, Inc. 1977. "Fundamentals of High Resolution Seismic Profiling," TR 76-035, Waltham, Mass.
- Fisk, H. N. 1947. "Fine-Grained Alluvial Deposits and Their Effects on Mississippi River Activity," Vol 1 of 2 Volumes, U. S. Army Engineer Waterways Experiment Station, Vicksburg, Miss.
- Flemming, B. W. 1976. "Side-Scan Sonar: A Practical Guide," International Hydrographic Review, Vol 53, No. 1, pp 65-92.
- Gregory, K. J., ed. 1977. River Channel Changes, Wiley-Interscience, New York.
- Hampton, Loyd, ed. 1974. Physics of Sound in Marine Sediments, Plenum Press, New York.
- Hersey, J. B. 1963. "Continuous Reflection Profiling," The Sea, Vol 3, Interscience Publishers, New York, pp 47-72.
- \_\_\_\_\_. 1979. "Underwater Acoustics - The Workhorse of Remote Sensing in the Ocean," Symposium on Remote Sensing of Environment, 13th Proceedings.
- Huysinga, J. K. and Biddle, A. R. 1978. "Shallow Seismic As An Aid to Locating Offshore Installations," Proceedings, Vol 2, Society of Petroleum Engineers, pp 425-432.
- Knott, S. T. 1970. "Operational Technique for Continuous Seismic Profiling and Related Studies," Reference No. 70-43, Woods Hole Oceanographic Institute, Woods Hole, Mass.
- Leenhardt, O. 1969. "Analysis of Continuous Seismic Profiles," International Hydrographic Review, Vol 46, No. 1, pp 51-80.
- \_\_\_\_\_. 1971. "Resolution in Continuous Seismic Profiling," International Hydrographic Review, Vol 48, No. 2, pp 71-83.
- Lincoln, W. B. 1979. "Underwater Search Using Side-Scan Sonar," Report No. CG-D-08-79, U. S. Coast Guard Research and Development Center, Groton, Conn.
- \_\_\_\_\_. 1979. "Acoustical Imaging of Manmade Objects on the Sea Floor," Symposium on Remote Sensing of Environment, 13th Proceedings.



- Moore, T. C. Jr. and Heath, G. R. 1978. "Seafloor Sampling Techniques," Chapter 32, Chemical Oceanography, 2d ed., Vol 7, pp 75-126.
- Murphy, W. L. 1980. "Surface and Subsurface Geologic Conditions Along Selected Reaches of the Mississippi River," U. S. Army Engineer Waterways Experiment Station, Vicksburg, Miss. (Unpublished).
- Parkinson, L. E. 1970. "Marine Gravel Prospecting," Underwater Science and Technology Journal, pp 63-68.
- Pawlowicz, E. F. 1971. "Ocean Engineering Significance of Marine Seismic Reflection Profiling Technology," Technical Note N-1157, Naval Civil Engineering Laboratory, Port Hueneme, Calif.
- Prior, D. B., Coleman, J. M., and Caron, R. L. 1979. "Sea Floor Mapping by Microcomputer-Assisted Side-Scan Sonar," Symposium on Remote Sensing of Environment, 13th Proceedings.
- Rubner, D. P. 1971. "Tanker Mooring Site Survey Equipment," Report 2014, U. S. Army Mobility Equipment Research Development Center, Ft. Belvoir, Va.
- Rusnak, G. A. 1967. "High-Efficiency Subbottom Profiling," Geological Survey Research, U. S. Geological Survey Professional Paper 575-C, pp C81-C91.
- Sangree, J. B. and Widmier, J. M. 1979. "Interpretation of Depositional Facies from Seismic Data," Geophysics, Vol 44, No. 2, pp 131-160.
- Sargent, G. E. G. 1969. "Further Notes on the Application of Sonic Techniques to Submarine Geological Investigations, with Special Reference to Continuous-Reflection Seismic Profiling," Proceedings, Ninth Commonwealth Mining and Metallurgical Congress, Great Britain, Vol 2, pp 95-128.
- Saucier, R. T. 1969. "Acoustic Subbottom Profiling Survey, Walter F. George Reservoir Alabama-Georgia," Miscellaneous Paper S-69-32, U. S. Army Engineer Waterways Experiment Station, Vicksburg, Miss.
- Schlank, J. J. Jr. 1968. "Subbottom Sounding - A Survey for Naval Applications," Thesis, U. S. Naval Postgraduate School, Monterey, Calif.
- Schubel, J. R. and Schiemer, E. W. 1972. "The Origin of Acoustically Turbid Sediments in Chesapeake Bay," Special Report 23, Reference 72-5, John Hopkins University.
- Shor, G. G. Jr. 1967. "Nonexplosive Profilers: Methods (Arcers, Sparkers, Boomers, Gas-Guns, Air-Guns and Similar Devices)," MPL-U-36/64, Office of Naval Research (Reprinted from International Dictionary of Geophysics, 2, Pergamon Press, London, pp 1018-1021).
- Sullivan, R. A. 1980. "North Sea Foundation Investigation Techniques," Marine Geotechnology, Vol 4, No. 1.
- U. S. Army Corps of Engineers. 1966. Symposium on Channel Stabilization Problems, Technical Report No. 1, Vol 4, Vicksburg, Miss.
- U. S. Army Engineer Division, Ohio River. 1977. "Ohio River Bank Erosion Study," U. S. Army Corps of Engineers, Cincinnati, Ohio.



Urick, R. J. 1971. "Some Perspectives and Recent Findings in Shallow Water Acoustics," NOLTR 71-204, Naval Ordnance Laboratory, White Oak, Silver Springs, Md.

Van Reenan, E. D. 1962. "Acoustic Study of Mississippi River Revetments," Report No. B-2370, EG&G International, Inc.



In accordance with letter from DAEN-RDC, DAEN-ASI dated 22 July 1977, Subject: Facsimile Catalog Cards for Laboratory Technical Publications, a facsimile catalog card in Library of Congress MARC format is reproduced below.

May, John R.

Engineering geology and geomorphology of streambank erosion : Report 3 : The application of waterborne geophysical techniques in fluvial environments / by John R. May (Geotechnical Laboratory, U.S. Army Engineer Waterways Experiment Station). -- Vicksburg, Miss. : The Station ; Springfield, Va. : available from NTIS, 1982. 239 p. : ill. ; 27 cm. -- (Technical report ; GL-79-7, Report 3)

Cover title.

"February 1982."

"Prepared for Office, Chief of Engineers, U.S. Army under Section 32 Program, Task II, Work Unit 4."

Bibliography: p. 235-239.

1. Erosion. 2. Engineering geology. 3. Geomorphology. 4. Geophysical instruments. I. United States. Army. Corps of Engineers. Office of the Chief of Engineers. II. U.S. Army Engineer Waterways Experiment Station.

May, John R.

Engineering geology and geomorphology of : ... 1982.  
(Card 2)

Geotechnical Laboratory. III. Title IV. Series:  
Technical report (U.S. Army Engineer Waterways  
Experiment Station) ; GL-79-7, Report 3.  
TA7.W34 no.GL-79-7 Report 3