

A7  
W34m  
no. CERC-  
83-5  
cop. 2



Army Corps  
Engineers

US-CE-C Property of the United States Government  
MISCELLANEOUS PAPER CERC-83-5

# BEACH CHANGES AT MILFORD AND FAIRFIELD BEACHES, CONNECTICUT, 1962-1971

by

Robert W. Morton, W. F. Bohlen, and David G. Aubrey

Science Applications, Inc.

379 Thames Street

Newport, Rhode Island 02840

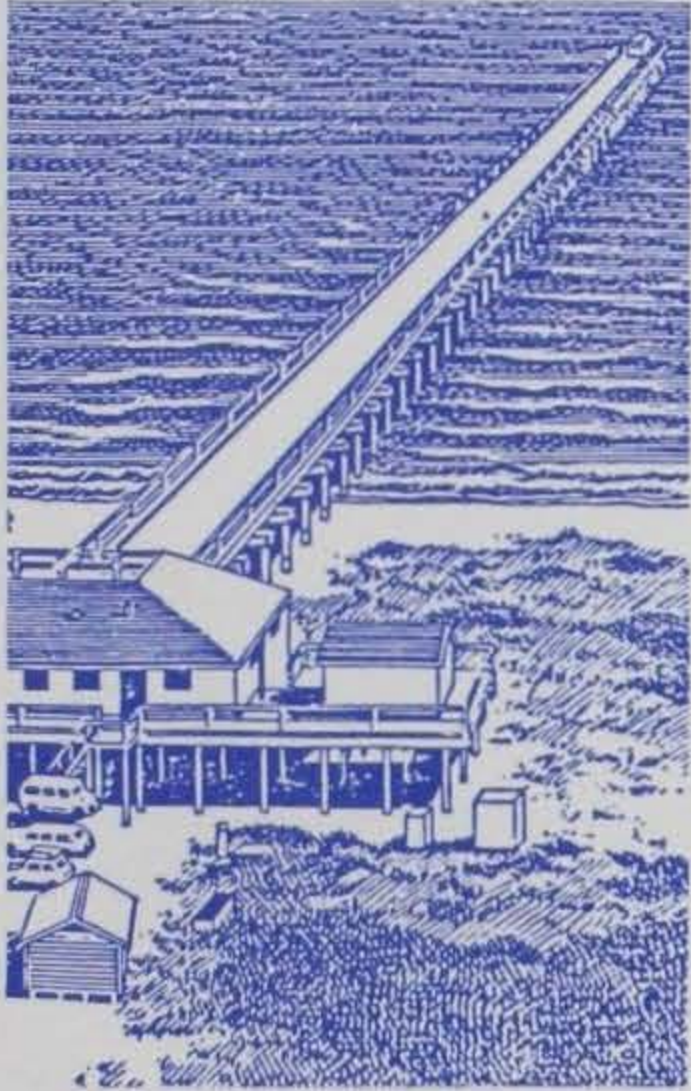

December 1983

Final Report

Approved For Public Release; Distribution Unlimited

Prepared for Office, Chief of Engineers, U. S. Army  
Washington, D. C. 20314

Under Contract No. DACW72-79-C-0020

Monitored by Coastal Engineering Research Center  
U. S. Army Engineer Waterways Experiment Station  
P. O. Box 631, Vicksburg, Miss. 39180

LIBRARY BRANCH

TECHNICAL INFORMATION CENTER

US ARMY ENGINEER WATERWAYS EXPERIMENT STATION  
VICKSBURG, MISSISSIPPI



Unclassified

SECURITY CLASSIFICATION OF THIS PAGE (When Data Entered)

REPORT DOCUMENTATION PAGE		READ INSTRUCTIONS BEFORE COMPLETING FORM
1. REPORT NUMBER Miscellaneous Paper CERC-83-5	2. GOVT ACCESSION NO.	3. RECIPIENT'S CATALOG NUMBER
4. TITLE (and Subtitle) BEACH CHANGES AT MILFORD AND FAIRFIELD BEACHES, CONNECTICUT, 1962-1971		5. TYPE OF REPORT & PERIOD COVERED Final report
		6. PERFORMING ORG. REPORT NUMBER
7. AUTHOR(s) Robert W. Morton, W. F. Bohlen, and David G. Aubrey		8. CONTRACT OR GRANT NUMBER(s) Contract No. DACW72-79-C-0020
9. PERFORMING ORGANIZATION NAME AND ADDRESS Science Applications, Inc. 379 Thames Street Newport, Rhode Island 02840		10. PROGRAM ELEMENT, PROJECT, TASK AREA & WORK UNIT NUMBERS Beach Profile Studies; Shore Protection and Restoration
11. CONTROLLING OFFICE NAME AND ADDRESS Office, Chief of Engineers, U. S. Army Washington, D. C. 20314		12. REPORT DATE December 1983
		13. NUMBER OF PAGES 115
14. MONITORING AGENCY NAME & ADDRESS (if different from Controlling Office) U. S. Army Engineer Waterways Experiment Station Coastal Engineering Research Center P. O. Box 631, Vicksburg, Miss. 39180		15. SECURITY CLASS. (of this report) Unclassified
		15a. DECLASSIFICATION/DOWNGRADING SCHEDULE
16. DISTRIBUTION STATEMENT (of this Report) Approved for public release; distribution unlimited.		
17. DISTRIBUTION STATEMENT (of the abstract entered in Block 20, if different from Report)		
18. SUPPLEMENTARY NOTES Available from National Technical Information Service, 5285 Port Royal Road, Springfield, Va. 22161.		
19. KEY WORDS (Continue on reverse side if necessary and identify by block number) Beach profiles Beaches--Connecticut Fairfield Beach (Conn.) Milford Beach (Conn.) Shore protection		
20. ABSTRACT (Continue on reverse side if necessary and identify by block number) Beach profile line data collected as part of the Beach Evaluation Program were examined for sites located at Milford and Fairfield, Connecticut. A total of seven profile lines were examined using standard measurements such as mean sea level intercept, above mean sea level volume, and linear wave refraction plots, as well as empirical eigenfunction analyses. All these methods showed erosion at all the lines at Milford, while Fairfield showed accretion at two out of three lines. <p style="text-align: right;">(Continued)</p>		

20. ABSTRACT (Continued)

Erosion rates for both beaches varied from 0.096 to 2.886 meters per year. The most significant factors affecting the short-term variability in beach volume are storm activity and wind direction. Each of the beaches is affected by longshore transport; however, transport at Milford is limited due to high-density shorefront housing and associated roads and seawalls. Fairfield favors northeast transport, but rates are unknown. Sediment supply for the beaches is limited, but both beaches are subject to onshore-offshore sediment transport. Neither of the beaches showed any significant seasonal changes.

The characteristics of the Connecticut beaches differ markedly from other, less sheltered beaches studied in this program, as they appear relatively stable and dominated by long-term trends.

## PREFACE

This report is one of a series of reports describing the results of the Beach Evaluation Program of the U. S. Army Engineer Waterways Experiment Station Coastal Engineering Research Center (CERC). One aspect of the program is to provide basic engineering information on changes in shoreline position, as obtained from long-term beach survey projects. The study of Milford and Fairfield beaches in Connecticut was begun in November 1962 and continued through April 1971. Profile data analysis was accomplished by CERC using the Beach Profile Studies work unit, Shore Protection and Restoration Program, Coastal Engineering Area of Civil Works Research and Development.

The report was prepared by Robert W. Morton (Principal Investigator), Science Applications, Inc. (SAI), of Newport, Rhode Island; W. F. Bohlen, Marine Science Institute, University of Connecticut, Groton; and David G. Aubrey, Woods Hole Oceanographic Institution, Woods Hole, Massachusetts; under Contract No. DACW72-79-C-0020. Eigenfunction analysis programs and refraction analysis were written by David G. Aubrey, while the remaining analysis software was provided by J. Karpen (SAI, Raleigh, North Carolina).

The authors acknowledge and express appreciation for the review comments provided by CERC. A. E. DeWall was Contract Monitor under the general supervision of Dr. R. M. Sorenson, former Chief, Coastal Processes and Structures Branch, and Mr. R. P. Savage, former Chief, Research Division. In July 1983 CERC became part of the U. S. Army Engineer Waterways Experiment Station (WES) under the direction of Dr. Robert W. Whalin.

Commander and Director of WES upon publication of this report was COL Tilford C. Creel, CE; Technical Director was Mr. F. R. Brown.

## TABLE OF CONTENTS

<u>Section</u>	<u>Page</u>
PREFACE	
I. INTRODUCTION	1
1. Background	1
2. Regional Setting	3
II. STUDY AREAS	4
1. Milford Beaches	4
2. Fairfield Beach	6
3. Littoral Processes	9
III. METHODS	18
1. Profile Lines and Monumentation	18
2. Survey Frequency	18
3. Analytical Procedures	24
IV. RESULTS	27
1. Linear Wave Refraction	27
2. Beach Profile Changes	27
3. Longshore Sand Transport	36
V. DISCUSSION	37
LITERATURE CITED	39
BIBLIOGRAPHY	
APPENDIXES	

## LIST OF TABLES

<u>Table</u>		<u>Page</u>
1	Summary of profile line information	19
2	Regression coefficients, Fairfield and Milford beaches	28
3	Mean beach eigenfunctions, Fairfield and Milford beaches	31
4	Demeaned beach eigenfunctions, Fairfield and Milford beaches	32

## LIST OF FIGURES

<u>Figure</u>		<u>Page</u>
1	Beach locations on Long Island Sound	2
2	Milford beaches, Connecticut	5
3	Fairfield Beach, Connecticut	8
4	Wind rose for the period 1 January 1962 through 31 December 1971	11
5	Mean monthly cyclone frequency	12
6	Annual cyclone occurrence, Long Island, N. Y.	13
7	Silver Beach MHW positions as a function of time	16
8	Seasonal survey frequencies for Milford beaches	20
9	Annual survey frequencies for Milford beaches	21
10	Seasonal survey frequencies for Fairfield beach	22
11	Annual survey frequencies for Fairfield beach	23
12	Definition of MSL shoreline and above MSL unit volume change	25
13	Wind vector plot for Bridgeport, Connecticut	35

## LIST OF APPENDIXES

- A Profile Line Documentation
- B Profile Line Survey Data for Myrtle Beach
- C Profile Line Survey Data for Fairfield Beach
- D Above Mean Sea Level Unit Volume Change for Myrtle and Fairfield Beaches
- E Change in Mean Sea Level Shoreline Position for Myrtle and Fairfield Beaches
- F Beach Profile Envelopes for Myrtle and Fairfield Beaches
- G Empirical Eigenfunction Analysis with Myrtle and Fairfield Beach Eigenfunctions
- H Wave Refraction Plots



BEACH CHANGES AT MILFORD AND  
FAIRFIELD BEACHES, CONNECTICUT, 1962-71

by

*R.W. Morton, W.F. Bohlen, and D.G. Aubrey*

I. INTRODUCTION

1. Background.

This report is one of a series of reports published to provide the analysis and interpretation of beach profile data obtained from 1962 to 1973 by the U.S. Army Coastal Engineering Research Center (CERC) as part of the Beach Evaluation Program (BEP, formerly known as the Pilot Program for Improving Coastal Storm Warnings or the Storm Warning Program). The BEP was initiated after the Great East Coast Storm of March 1962 to observe variations on typical beaches in response to waves and tides of significant intensity and duration. The twelve beaches in the region hardest hit by that storm (from Massachusetts to North Carolina) are under study in this program. Other applications of the BEP include generating a predictive model of beach erosion (Galvin, 1969) and providing basic engineering information for the planning and design of protective structures or remedial strategies for stabilizing and maintaining beaches (Everts, 1973).

This report presents an analysis of the beach profile data obtained from surveys of profile lines on two beaches in the vicinity of Bridgeport, Connecticut. Four profile lines were established on the Milford beaches, located approximately 8 kilometers east of Bridgeport, and three lines were established on Fairfield Beach, 6.5 kilometers west of Bridgeport in the town of Fairfield (Fig. 1). Replicate measurements of vertical beach profiles were made between November 1962 and June 1971 by the U.S. Army Engineer Division, New England. Surveys were made only to wading depth and do not include near-shore. All profile line locations are documented (App. A), and measurements of elevation above mean sea level (MSL) are presented for each measurement period (Apps. B and C). An analysis of these data is provided which evaluates changes in beach elevation, sand volume, and shoreline position resulting from the wave regime, water level, and storm events that occurred during the period of the surveys. In addition, previous work in the area is reviewed to examine long-term trends in waves, winds, and tides and to develop a framework in which to interpret beach changes.

Variability in the shape of the beach was evaluated with standard methods utilized at CERC (Apps. D, E, and F) and with empirical eigenfunction techniques (App. G). Of particular note were changes in the beach elevation, slope, volume, and MSL intercept resulting from particular storm events. Changes were evaluated over three time scales:

- (a) Long-term changes that occur over periods of a year or longer;
- (b) seasonal changes occurring over a typical three-month period; and
- (c) short-term changes resulting from specific storms or wind-stress events between surveys.

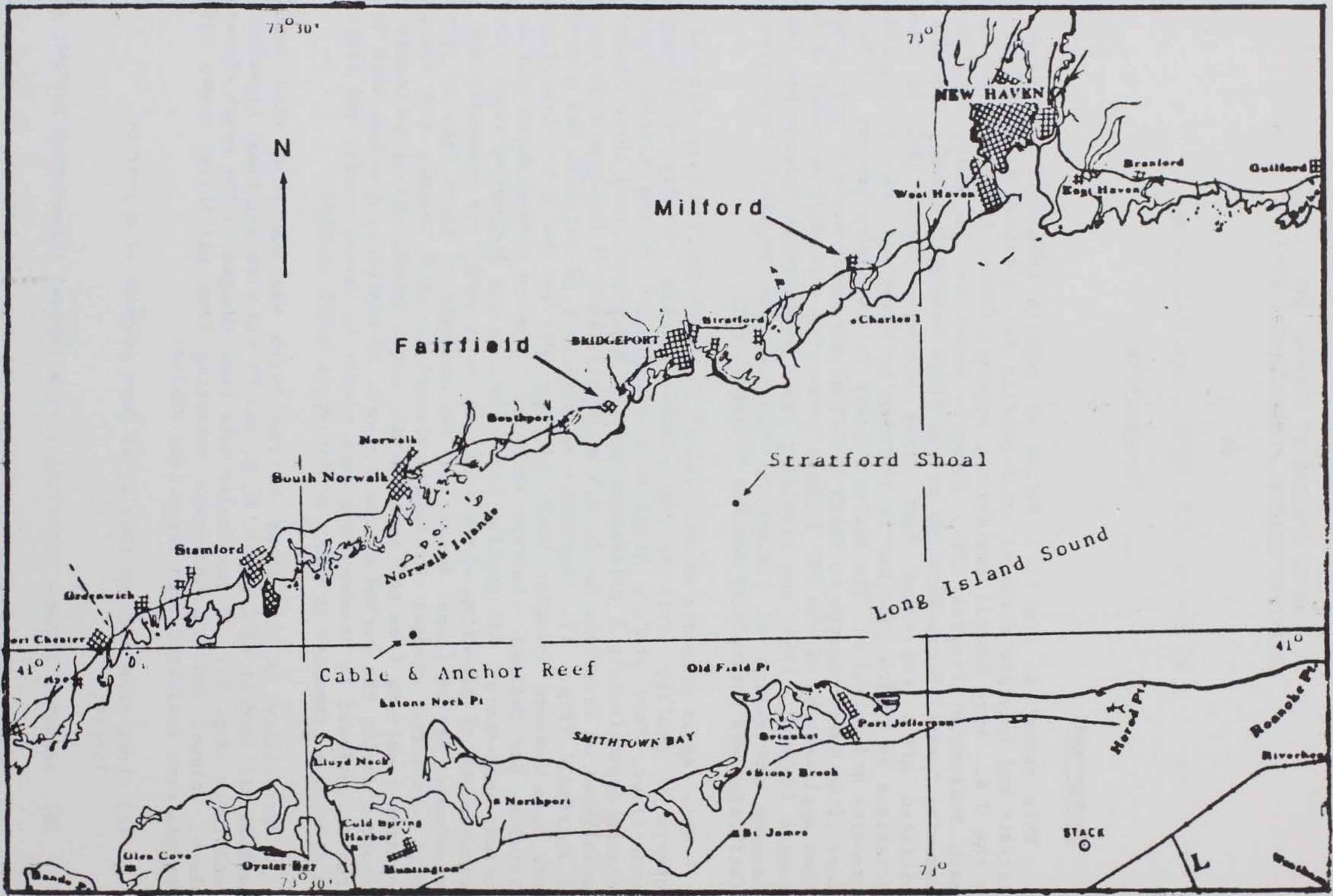

Figure 1. Beach locations on Long Island Sound.

## 2. Regional Setting.

Dominated by its glacial character, the coastline of Connecticut along Long Island Sound (Fig. 1) is deeply incised and displays a high degree of spatial variability. This shoreline margin consists of a variety of small embayments and estuaries typically separated by till headlands and displaying variant orientation and composition. Unconsolidated sediments are supplied to the coastal area by a variety of sources, including upland glacial deposits, eroding till headlands, and the adjacent offshore (Flint, 1930). This combination of variable geomorphology and sediment source creates differences in local beach behavior (McCabe, 1970) and dominant direction of longshore transport (State of Connecticut, 1979). Despite this variability, however, many of the sand beaches within the sound appear at present to be experiencing erosion of varying degrees (State of Connecticut, 1979). The erosion is primarily the result of a limited sediment supply, advancing sea level, and constraints on beach mobility imposed by high density shore-front housing (Sanders and Ellis, 1961; Bloom, 1965; State of Connecticut, 1979). For Fairfield Beach and the area of the Milford beaches, erosion and its governing factors were first detailed by studies conducted by the U.S. Army Corps of Engineers (U.S. Army Engineer Division, New England, 1949; 1951). The studies proposed a variety of structural schemes, including groins and direct sand placement to reduce or control erosion. In both areas some of these recommendations were implemented (State of Connecticut, 1979). Despite these efforts, however, recent surveys of the Milford beaches (Jacobson, et al., 1981) and visual surveys of Fairfield Beach, conducted as a part of this study, indicate a continuing dominance of erosion over major portions of each beach.

## II. STUDY AREAS

### 1. Milford Beaches.

a. Geology and Geomorphology. The Milford beaches are located along the northern shore of Long Island Sound, approximately 16 kilometers to the west of New Haven and 9.6 kilometers east of Bridgeport, in the Town of Milford, Connecticut (Fig. 1). This beach area forms a portion of a long, relatively continuous, sandy shore extending from Burns Point, adjacent to the entrance of Milford Harbor, west to Milford Point, which is the eastern boundary of the mouth of the Housatonic River (Fig. 2). Along this section of the shoreline, Charles Island and its attached submerged tombolo spit (or bar) represent the most prominent physical feature (Fig. 2). The section of the shore known as Myrtle Beach extends west from the landward terminus of the Charles Island bar for a distance of approximately 1,700 meters to the vicinity of Naugatuck Avenue. In other studies (e.g., Jacobson, et al., 1981), the section of beach called Myrtle Beach is subdivided into Walnut Beach, Myrtle Beach, and Silver Beach. This report refers to this amalgamation of beaches as Myrtle Beach. To the east of the Charles Island bar, Silver Beach extends for approximately 670 meters (U.S. Army Engineer Division, New England, 1951). Together, these beaches form a barrier fronting the Meadows End tidal marsh complex, which is an area severely impacted by historical use as a refuse disposal site. At present the State of Connecticut is developing this area as Silver Sands State Park.

The sediments forming Myrtle Beach consist of a size range of graded sands through boulders. Along the western limits, upper beach materials are generally medium to coarse grain sands, with fine to medium grain sands dominating the intertidal zone. Proceeding eastward, beach materials become progressively coarser, giving way to gravel, cobble, and fill-placed boulders in the area extending 425 meters west of the tombolo. Silver Beach sediments consist primarily of medium to coarse grain sands, with fine to medium grain sands found in the intertidal zone (Jacobson, et al., 1981).

The bulk of the sediments found along Myrtle and Silver Beaches is glacial in origin, supplied as outwash or by the erosion of adjoining till headlands or offshore deposits. Of these latter source areas, Charles Island and the Knobb Hill headland in the vicinity of Welches Point (Fig. 2) represent the primary sites affecting sediment supply to the study area. The gradual denudation or stabilization of these areas has resulted in a reduction in sediment supply and has contributed to the progressive erosion of the shore (U.S. Army Engineer Division, New England, 1951).

The planform contours of Myrtle and Silver Beaches display a high degree of spatial variability. Proceeding east from the western limit of the beach, the present high water line is in close proximity to the bordering housing. The beach expands abruptly 270 meters to the east of Naugatuck Avenue and maintains a width of at least 45 meters east to Nettleton Avenue and its associated timber groin extension (Fig. 2). This increase in beach width is associated with a landward offset in shore-front housing, and not a seaward offset in the mean water contour. This section of the shore is relatively featureless with irregularities associated primarily with through-beach piping for street drains. There is no evidence of natural rhythmic periodicity. Immediately to the east of the present timber groin, beach width increases to approximately 60 meters. Continuing to the east, beach

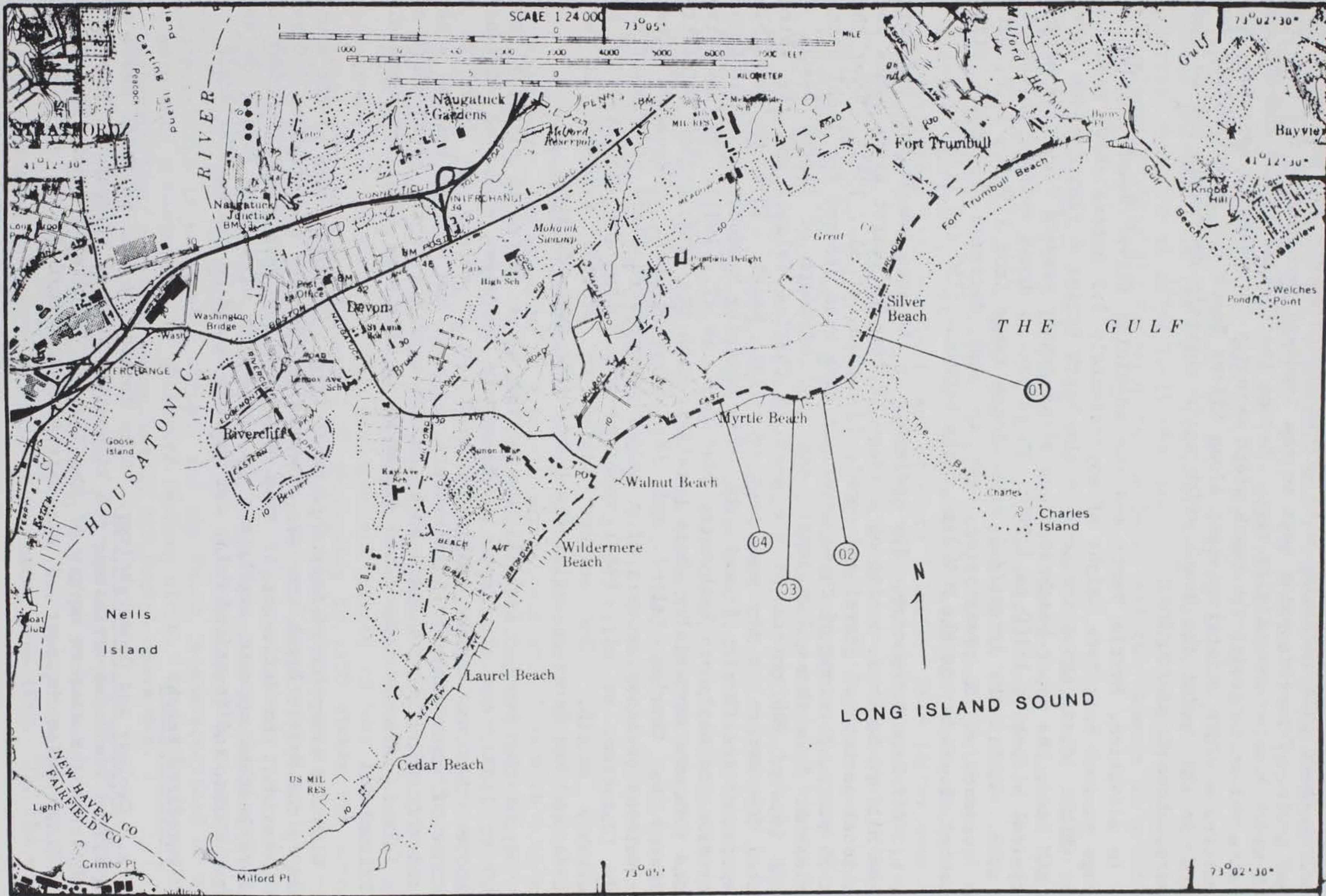

Figure 2. Milford beaches, Connecticut.

width progressively decreases and the high water line intersects the bordering sheet pile retaining wall within approximately 210 meters of the timber groin. From this point east to the landward terminus of the bar, the beach width remains essentially zero. Beyond the Charles Island tombolo and its attached stone groin, the beach width abruptly increases to approximately 59 meters, a width maintained east along Silver Beach for approximately 240 meters. At this point the beach width again abruptly decreases due to high density, shore-front housing.

In elevation, Myrtle Beach and the adjoining Silver Beach display an average maximum backshore height of approximately 3.5 meters above mean low water (MLW). Along those sections of the beach having a finite width above the MLW line, the upper beach sections slope gently seaward from this height on typical slopes of 1:100 to 1:200. There are no dunes evident throughout the area. Within the intertidal zone slopes range from 1:50 to 1:20, with some evidence of a progressive east to west decrease in grain size. Nearshore slopes beyond the MLW line range between 1:150 and 1:200.

b. Offshore Bathymetry. The sediments in the area immediately offshore of the Milford beaches consist of a range of fine to coarse grain sands and occasional pockets of gravel and cobble (Jacobson, et al., 1981). Over the past 25 years, portions of these materials have been dredged for local beach nourishment from three locations: one just offshore of Laurel Beach, a second located 900 meters to the west of Charles Island, and the third located 300 meters to the southeast of Silver Beach. With the possible exception of the Charles Island site, this dredging produced no significant alterations in nearshore bathymetry (Jacobson, et al., 1981). The isobaths in the area are essentially shore parallel, with the distribution evidently dominated by Charles Island and its attached bar. Side-scan sonar observations obtained as part of a recently completed State of Connecticut study (Jacobson, et al., 1981) reported the bottom in the area to be remarkably smooth. The surveys failed to provide evidence of any well-defined bed forms at scales resolvable with the side scan.

Beyond the 6-meter isobath, the bottom slope decreases slightly from 1:200 to 1:300, and the depth progressively increases with the distance offshore. Maximum depths ranging from 36 to 42 meters are found at a distance of approximately 16 kilometers south of the Milford beaches area. Beyond this point depths again shoal on the approach to the north shore of Long Island. Average cross-sound distances in this area equal approximately 21 kilometers.

With the exception of Stratford Shoal (Fig. 1), the waters of the sound fronting the Myrtle Beach area are essentially open and unobstructed. Given its location, the influence of this shoal on the wave field incident on Milford beaches appears negligible in comparison with Long Island on the larger scale, and Stratford Point and Charles Island on the smaller scale.

## 2. Fairfield Beach.

a. Geology and Geomorphology. Also located on the northern shore of Long Island Sound, approximately 6.4 kilometers west of Bridgeport, Fairfield Beach forms the eastern margin of the Town of Fairfield, Connecticut (Fig. 1). This region is part of the Fairfield-Stratford Plain, an area 12.8

kilometers long and 1.6 kilometers wide, representing the largest flatland along the coast of Connecticut (U.S. Army Engineer Division, New England, 1949). The beach, which extends approximately 1.8 kilometers north-northeast from Shoal Point to the entrance of Ash Creek (Fig. 3), has historically served as a barrier separating the low-lying inland plain and associated tidal marshes from the open waters of Long Island Sound. Currently, this barrier function is effectively obscured by the high density of recreational development along and adjacent to the beach and the absence of a definable dune line.

The sediments dominating the foreshore of Fairfield Beach consist primarily of medium to coarse grain sands. The textural character along the entire beach is quite uniform, with little evidence of wind or wave-induced sorting, except in the area immediately adjacent to Shoal Point. The shore front sediments are glacial in origin (supplied by melt water runoff during glacial retreat), and the progressive erosion and weathering of unconsolidated till headlands and offshore islands. This latter source area (represented by Penfield Reef extending southeast from Shoal Point) appears to have been particularly prominent throughout the history of Fairfield Beach. Reviews indicate that during the late 1600's an emergent peninsula extending for well over a mile into the sound existed in this area (Steinke, 1982). In the 1700's, following removal of a large amount of cobble for use as ship's ballast, the peninsula began to erode rapidly, and by the late 1800's was largely submerged, forming a reef and island complex. Despite some management efforts, progressive erosion of the island continued until it was finally obliterated by the 1938 hurricane, resulting in the present submerged reef and shoal. The reef has supplied sediments to the longshore cell active along Fairfield Beach, and in addition, has resulted in some modification of the transport energy levels incident on the beach. This latter factor will be discussed in more detail below.

The sediment distribution along Fairfield Beach, between Ash Creek and Shoal Point, has resulted in a smooth curvilinear shoreline with a relatively featureless planform. There are no promontories along the beach or structures with wave-induced spatial periodicity. Currently, the width of the beach, from the backshore margin to the MHW line, varies from approximately 46 meters adjacent at the entrance to Ash Creek, to less than 15 meters along the southern limits of the beach north of Shoal Point. The present beach contours display a spatial variability in elevation, but only limited seasonal variability. Along the southern limits of the beach, foreshore slopes average approximately 1:30 decreasing to 1:50 within the intertidal zone. In the back shore, beach slope gradually decreases to form a narrow, nearly horizontal berm adjacent to a backshore seawall. Beach elevations at the seawall average approximately 3.2 meters above MLW. Proceeding northward, foreshore slopes progressively increase, reaching approximately 1:10 near the entrance to Ash Creek. In this area the transition to the upper beach is noticeably abrupt, and the beach is characterized by a broad berm with a horizontal or shoreward tending slope. Sand elevation along the backshore limit averages approximately 3.8 meters above MLW.

b. Offshore Bathymetry. The offshore area immediately adjacent to Fairfield Beach is comprised primarily of fine to medium grain sands with occasional pockets of glacial till. With the exception of Penfield Reef, which dominates the southern limit of the study area (Fig. 3), the nearshore

area is essentially smooth and featureless and displays a gradual seaward slope of approximately 1:200.

Beyond the immediate beach area, to the south of Penfield Reef, water depths progressively increase, reaching a maximum of approximately 40 meters along the channel located approximately 13 kilometers south of the study area. Beyond this line the bottom slope trend reverses and depths progressively shoal on approach to the northern shore of Long Island. The average separation between the Connecticut and New York shorelines in this area is approximately 19 kilometers.

On a larger spatial scale, the isobaths of western Long Island Sound are, for the most part, shore parallel and east-west tending. Stratford Shoal (located approximately 13 kilometers southeast of Shoal Point) and Cable and Anchor Reef (sited 18 kilometers southwest of Shoal Point) represent the only significant departures from this pattern (Fig. 1). The effects of these shoals on the wave field incident along Fairfield Beach appear to be minor in comparison with the influence exerted by Long Island on the larger scale and Penfield Reef on the smaller scale.

### 3. Littoral Processes.

The sediment transport system governing the shape and composition of the Milford beaches and Fairfield Beach results from a variety of factors, including tides and tidal currents, winds, local sea level characteristics, surface waves, and man's activities. These factors act individually and collectively to affect the overall stability and ultimate utility of the beach.

a. Tides. Tides within Long Island Sound are dominantly semidiurnal and have a mean range of 2 meters and a spring range of 2.34 meters. There is no significant difference in ranges between Milford and Fairfield beaches. However, there is a slight difference in the velocity of the tidal currents for the respective beaches. At Milford, tidal currents in the area immediately north of Charles Island have peak velocities of approximately 0.25 meter per second on both the southwesterly flood and northwesterly ebb (National Oceanic and Atmospheric Administration, 1975). More recent drifter observations made in the area adjacent to the Milford beaches inshore of Charles Island indicate a similar range of velocities with complex flow patterns in the area adjacent to and slightly east of the bar (Jacobson, et al., 1981).

Tidal currents in the area east of Fairfield Beach near the entrance to Bridgeport Harbor display peak velocities of approximately 0.30 meter per second. Maximum velocity on the easterly ebb equals 0.25 meter per second (National Oceanic and Atmospheric Administration, 1975). Given the distance between the referenced current stations and the study area, and the extent of the shallows fronting the beach, these observations are little more than an indication of the range of tidal currents expected near Fairfield Beach.

Stillwater elevations can be significantly perturbed during aperiodic storm events. Recent reviews of U.S. Army Corps of Engineers floodtide data indicate that the annual average storm impacting Long Island Sound produces a storm surge in the Milford area of approximately 0.8 meter thereby increasing the mean high tide (MHT) elevation to 2.8 meters above MLW (Jacobson, et al.,



1981). The less frequent but more intense 10-year storm would increase MHT elevations to 3.4 meters, while the 100 year storm, such as the 1938 hurricane, would increase maximum water levels to 3.9 meters. In the Fairfield area, the 100-year storm combined with spring high water conditions would result in sea level stands of approximately 4.1 meters above MLW (U.S. Army Engineer Division, New England, 1962, 1963). This would flood an area approximately 1000 meters to the west of Fairfield Beach, which is characterized by high density residential development. In both Milford and Fairfield the low elevation characterizing the backshore combined with the expected tidal surge in the event of such a storm would result in a potential for extensive storm damage to local areas.

b. Winds. In both study areas, the wind field is seasonal in character, with southwesterlies favored during the summer and northwesterlies during the winter (Fig. 4). From the orientation of the area it appears that the beaches are the most sensitive to winds from the east through south sectors. Reviews of meteorological observations obtained at Bridgeport indicate that easterly winds prevail approximately 20 percent of the time during a typical year. Winds from the west and southwest prevail for approximately 50 percent of the time. During periods of winds more than 60 kilometers per hour, easterlies prevail for approximately 50 percent of the time and westerlies for 35 percent of the time.

Aperiodic storm events can occur throughout the year but are most usually confined to the late fall, winter, and early spring as shown by a monthly average of cyclone intensity over the period 1885-1982 (Fig. 5). The months from November through April show a mean value of 2.2 cyclones per month, or greater. The months of June through September show monthly cyclone frequencies of less than 1.3 cyclones per month, while the months of May and October have intermediate values. If the beaches are insensitive to the direction of cyclone winds, they could be expected to reflect this seasonal storm activity. However, peak winds from these storm events generally come from the easterly or westerly sectors. Winds rich in northerly or southerly components usually represent transient conditions occurring during the passage of the storm center or associated frontal system. Again the orientation of the shoreline position indicates that those storms dominated by easterly winds may produce the most significant impacts along the Milford beaches.

The interrelationship between the storm activity and beach response is difficult to define in a historical sense. Generally, only storm history or beach response is well known, with the other (history or response) roughly estimated from one of several sources. Direct measurements during destructive storm events are particularly difficult to obtain, due to lack of direct measurements. Historical storm accounts are generally incomplete and often inaccurate. Wave hindcasts are only now becoming available, and need to be verified for most coastal locales before being used indiscriminately.

As an alternative to a historical compilation, a listing of all cyclones (both tropical and extra tropical) reaching the geographical limits of 70° W. to 75° W., 40° N. to 42.5° N., was used as an indicator of storm activity (Hayden and Smith, 1982). This information (Figs. 5 and 6) shows high storm activity in the early 1970's, with relatively less occurring in surrounding periods. The hypothesis that the number of storms is an indicator of storm

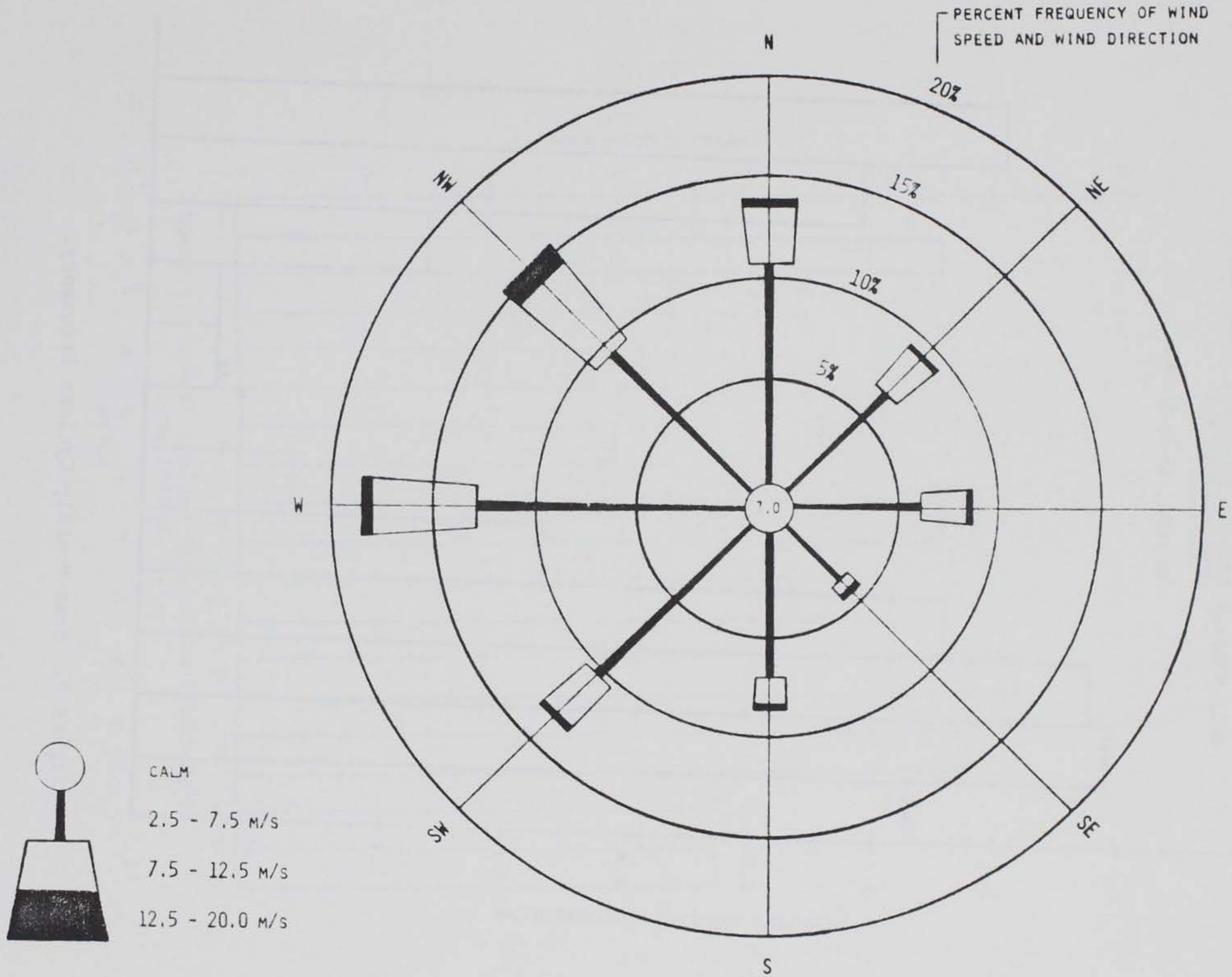

Figure 4. Wind rose (Bridgeport, Connecticut) for the period 1 January 1962 through 31 December 1971.

MEAN MONTHLY CYCLONE FREQUENCY (1885-1982)  
LONG ISLAND, N.Y.

(70-75°W., 40-42.5° N.)

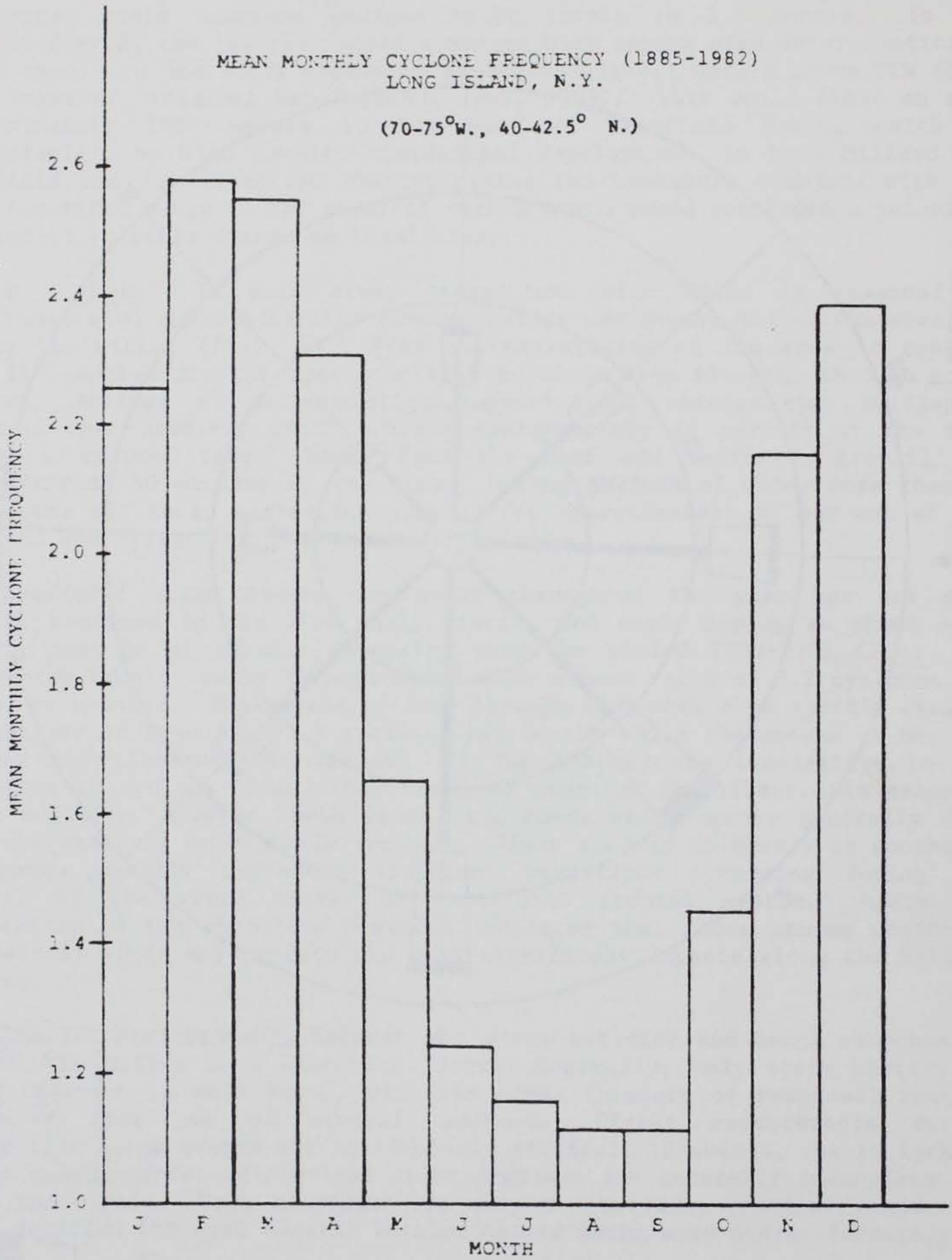

Figure 5. Mean Monthly Cyclone Frequency.

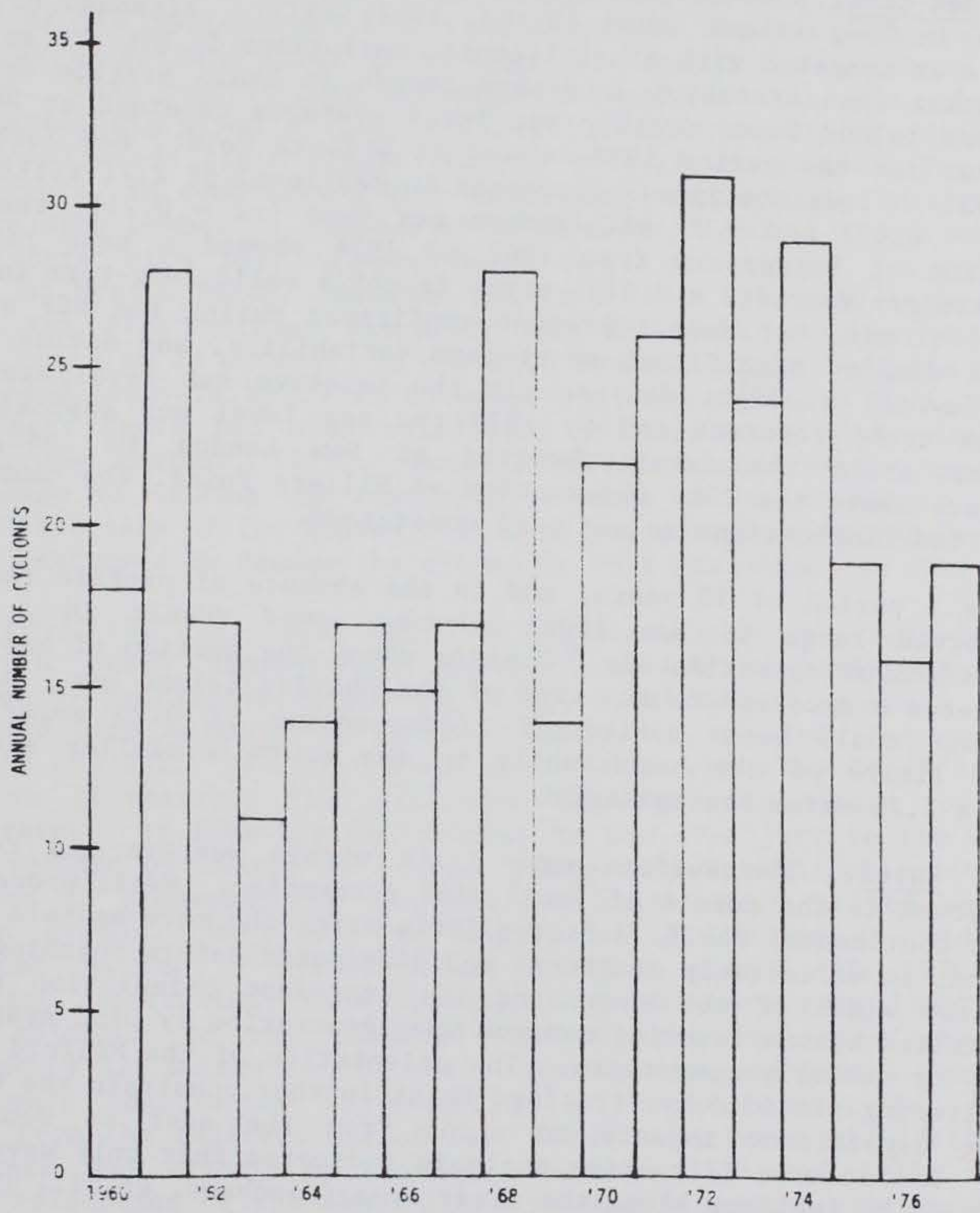

Figure 6. Annual Cyclone Occurrence (1960-1977)  
Long Island, N.Y.

severity is clearly erroneous as proven by the years 1962 and 1963, during which destructive storms hit the Connecticut coast. Current cyclone information does not reflect storm intensity (hence, erosion potential). Lacking other storm or wave compilations, Figure 6 can be used as a rough measurement of storm intensity for the period of the study.

c. Sea Level. Local studies of sea level indicate a consistent, long-term rise in Long Island Sound (Hicks, 1968; 1972). Although of secondary importance as compared with other factors, variations in MSL are an important consideration when assessing long-term trends in beach profile development. Within Long Island Sound monthly sea level averages obtained at New London, Connecticut for the period 1938-74 and at Willets Point, New York, for the period 1932-73 indicate annual increases in sea level of 2.71 millimeters per year ( $r^2 = 0.67$ ) and 3.33 millimeters per year ( $r^2 = 0.71$ ), respectively. Tide gaging at Bridgeport from 1967 to 1974 showed a mean rise of 7.0 millimeters per year ( $r^2 = 0.44$ ), which is not a valid long-term indicator of sea level trends, but does represent conditions during the BEP study. All data sets display significant short-term variability, and during the period 1960-65 favored a slight decrease in the relative sea level stand. After 1965 this trend reversed and by 1970 the sea level was approximately 1.0 centimeter above the level observed at New London in 1960, and 4.0 centimeters above the 1960 observation at Willets Point. The cause of these short-period fluctuations is not well understood.

Over a period of 10 years, and in the absence of profile readjustment, the observed range of sea level advance could result in a horizontal transgression of approximately 0.7 meter along the section of beach adjacent to Nettleton Avenue and to the east of the Charles Island bar. At Fairfield the result could be a horizontal transgression of 0.25 meter along the northern limits of the beach while to the south a similar advance would produce a 1.25-meter transgression.

d. Waves. The surface wave field within western and central Long Island Sound is the result of local wind generation. Swell propagation from adjacent continental shelf, a factor influencing the more eastern sections of the sound, is effectively scattered and dissipated before reaching this area. The narrow width of the sound and its east-west orientation result in a fetch-limited system favoring maximum wave generation by wind systems rich in easterly or westerly components. The orientation of the Milford beaches and the sheltering provided by Stratford Point further constrain the wave system, limiting significant impacts to winds from the east to south-southwest sector. Recent wave refraction analysis indicates that only waves from this sector will be incident along the study area (Jacobson, et al., 1981). Waves from the more northerly sectors effectively bypass the area.

Detailed information concerning the characteristics of waves incident along Myrtle Beach is limited. A short series of limited direct wave observations obtained, using a bottom-mounted pressure transducer maintained at Cable and Anchor Reef during the period 19 February through 27 March 1975, indicate that significant waves with periods in excess of 4 seconds are produced only by winds from the northeast through the southeast sectors (Bokuniewicz, et. al., 1975). High energy winds from other directions generate steep seas having relatively short periods and wavelengths. Data

detailing the frequency of occurrence of these varying wave fields are not available.

e. Man's Activities. Over the years, the Myrtle and Silver Beach areas have been significantly affected by man's activities. Beginning in the late 1800's, the area was subjected to progressive recreational development. By 1934, virtually the entire shore-front beach from Burns Point to the entrance of the Housatonic River (including the Charles Island shore front) was of the Housatonic River (including the Charles Island shore front) was developed. This construction and roadway placement eliminated the dune line and prevented migration of the barrier, thereby reducing the ability of the beach to withstand storm surges and the effects of an advancing sea level. These factors, in combination with decreasing sediment supply resulting from the increasing number of protective structures, favored progressive erosion of the shore with particularly high rates of retreat occurring in the vicinity of Myrtle Beach. Between 1884 and 1949, the mean high water (MHW) line in the area between Naugatuck and Nettleton Avenues was displaced landward by 15 to 30 meters. In the area immediately west of the bar the MHW line receded landward by 30 to 60 meters between 1884 and 1933, and by 1949 the emergent beach had been eliminated in this area (U.S. Army Engineer Division, New England, 1951). Associated with this erosion was continuing storm damage to housing and roadways. Reviews of aerial photos of the area indicate that many of the houses that were present along Myrtle Beach in 1934 had been destroyed or damaged by storms by 1951 (Jacobson, et al., 1981).

In 1960, the U.S. Army Corps of Engineers made an effort to stabilize the Myrtle Beach shore-front and protect the adjoining roadways and properties by hydraulically placing 178245 cubic meters of sand, obtained at an offshore site adjacent to Charles Island, in the area between Nettleton Avenue and the bar. Fill placement was used to widen the beach in this area from 30 to 76 meters. Fill placement, however, did little to reduce the erosion rates. By 1962 the shore-front in the area just to the west of the bar had receded by nearly 30 meters. Materials were displaced to the west and served to progressively increase the beach width in the area west of Nettleton Avenue. By 1968, an additional 15 meters in width of the easternmost section of Myrtle Beach had been eroded. In 1972 two stone groins were constructed, each approximately 107 meters in length. One is located adjacent to the landward end of the bar, and the other is approximately 425 meters to the west. During the same period several timber jetties were constructed to establish a channel outlet for storm-water drainage from the adjacent backshore. These structures did little to limit wave attack and associated erosion. Between 1965 and 1975, undermining required relocation of the shore-front roadway along the eastern sections of Myrtle Beach. However, these efforts proved to be only temporary, and by 1980 the road was determined to be nonmaintainable and was abandoned. At present, the shoreline is substantially inshore of the contour observed in 1949 (U.S. Army Engineer Division, New England, 1951), except in the area west of Nettleton Avenue where there is slight net accretion (Fig. 7).

At Silver Beach, the magnitude of beach change was much less than at Myrtle Beach. A maximum net erosion of about 15 meters has occurred along Silver Beach in the 30-year period between 1949 and 1979. Generally, net erosion has been less than 15 meters along Silver Beach.

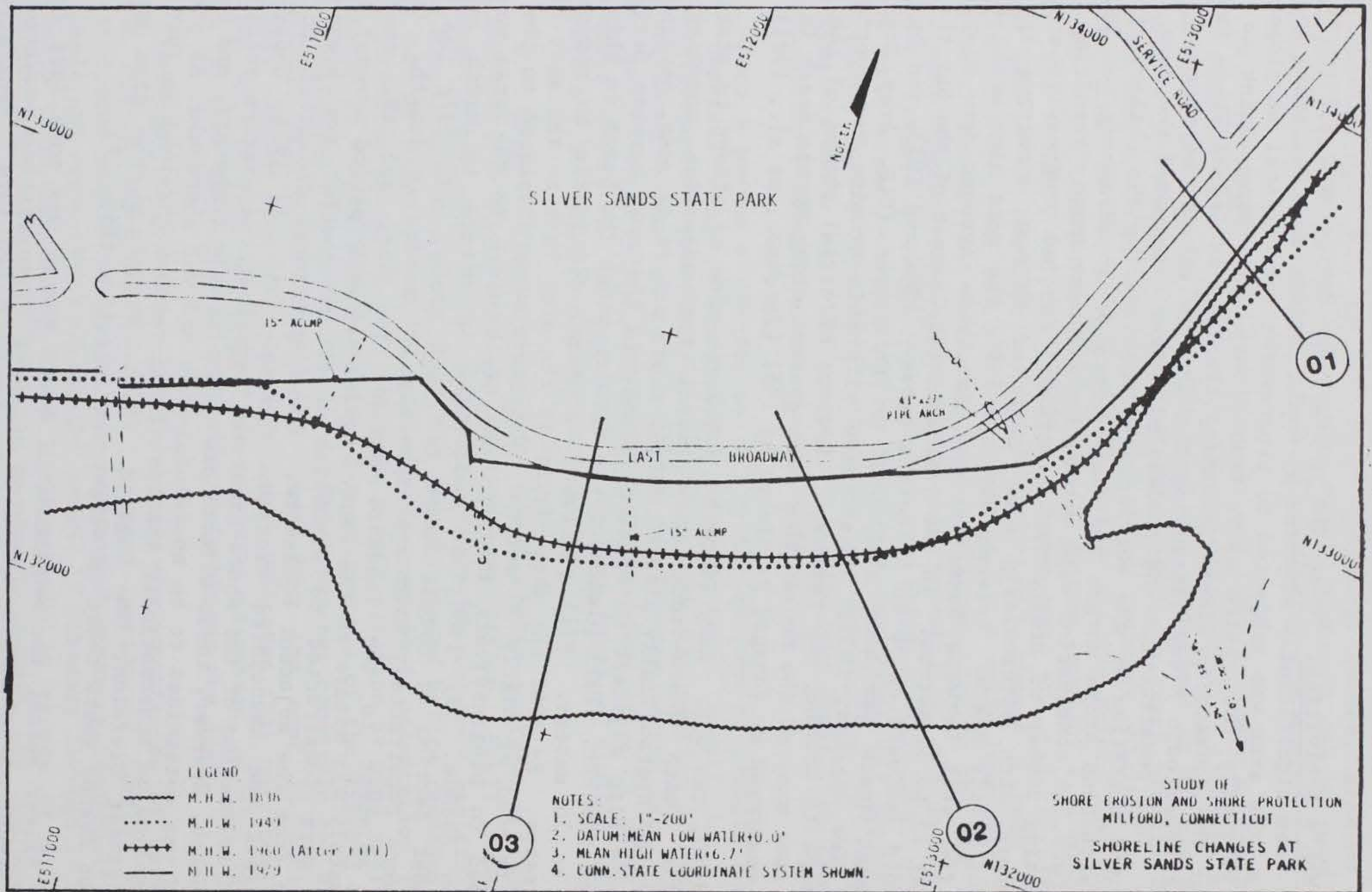

Figure 7. Silver Beach MHW positions as a function of time.

For more than 100 years the shape and composition of Fairfield Beach has been affected by the activities of man. Initially, these activities were confined along the southern limits of the beach, and included farming of the backshore, grazing of stock, and the removal of ballast stone described above. By the late 1800's, a recreational community began to develop along the beach in the vicinity of Shoal Point. By 1931 nearly 400 seasonal homes were located in the area centered on Shoal Point, extending north up Fairfield Beach and west to the entrance of Pine Creek (Steinke, 1982). With the gradual destruction of Penfield Reef and the associated reduction in sediment supply and increasing incident wave energy, shore-front erosion accelerated and numerous seawalls and pile and timber groins were erected in an effort to stabilize the shore-front properties. By 1948 a continuous concrete seawall, with a crest elevation of approximately 3.2 meters (+MLW), formed the inshore boundary of Fairfield Beach along the southern limits, extending 609 meters north and east of Shoal Point. To the west of Shoal Point, a network of eight timber groins was constructed (U.S. Army Engineer Division, New England, 1949). Despite these efforts, portions of the beach continued to experience severe erosion with the high water line moving shoreward at a rate of approximately 0.3 to 0.6 meter per year. Erosion was particularly pronounced along the southern limits of Fairfield Beach.

Following the 1949 evaluation of the extent and causes of erosion along Fairfield Beach (U.S. Army Engineer Division, New England, 1949), several projects were initiated in an effort to reduce erosion and to increase the recreational utility of the beach. In 1951, a 213-meter-long stone jetty was constructed at the mouth of Ash Creek. This structure was intended to form the northern terminus of Fairfield Beach and to stabilize the entrance to Ash Creek, which had migrated westward more than 122 meters since 1835.

The stabilization of Ash Creek was followed in 1958 by the construction of two stone groins, each 99 meters in length. These structures were placed along the southern limits of Fairfield Beach approximately 105 and 335 meters north of Shoal Point, respectively. At the completion of the groin construction, sandfill (hydraulically pumped from an area 762 meters south of Shoal Point) was placed along the southern limits of the beach. Approximately 106000 cubic meters of sand was placed along a 1340-meter section of beach extending north from Shoal Point. At the completion, a minimum beach width of 30 meters above MHW had been established along the entire length of Fairfield Beach.



### III. METHODS

#### 1. Profile Lines and Monumentation.

Four profile lines were monitored on the Milford beaches during the BEP survey period (Fig. 2). Profile lines 1, 2, and 4 were established at the beginning of the study and line 3 was added in December 1965. It is important to note that profile line 1 is actually located on Silver Beach, east of the tombolo associated with Charles Island and is oriented in an eastern direction, while the other profile lines are west of the tombolo and oriented in a southern direction.

Three widely spaced profile lines were established on Fairfield Beach (Fig. 3), and although profile line 1 was not measured on the first survey in November 1962, all three lines were included in subsequent surveys. The azimuth of all Fairfield beach profiles was generally in an eastern direction (100 to 124o).

The landward end of each profile line was recovered in September 1974 by personnel from the U.S. Army Engineer Division, New England, and concrete monuments with brass plates were installed to facilitate rapid relocation (Czerniak, 1974). The profile monuments were surveyed to third-order accuracy and referred to the Connecticut State plane coordinate system. Horizontal control was maintained for each monument with relation to fixed cultural landmarks, e.g., roadways, buildings, telephone poles, etc. Detailed monumentation plots showing the position of each profile line are in Appendix A, and a summary of data pertinent to the profile lines is in Table 1.

The surveying crews used the level and tape technique to measure the profile lines. A reference elevation was established at a fixed object such as the top of a log barricade, the foot spike on a telephone pole, or nail markers driven into the roadway. The survey was conducted seaward, along a predetermined azimuth which was perpendicular to the shoreline. Measurements were made at 15-meter intervals with each reading rounded to 30 centimeters in the horizontal and 3 centimeters in the vertical plane. Surveys were conducted to 0 MLW contour.

#### 2. Survey Frequency.

Surveys were conducted at Myrtle Beach profile lines 1, 2, and 4 beginning 9 November 1962, approximately every 2 weeks until January 1964. Thereafter, until the end of surveying on 19 April 1971, surveys were conducted at monthly, seasonal, or longer intervals. Surveying commenced at profile line 3 on Myrtle Beach beginning 20 December 1965, and ended 16 June 1970. Surveys were conducted monthly, seasonally, or at longer intervals as in the case of profile lines 1, 2, and 4.

Surveys were conducted at Fairfield Beach profile line 1, beginning 13 December 1962, approximately every 2 weeks until January 1964. Thereafter, until the end of surveying on 20 April 1971, surveys were conducted at monthly, seasonal, or longer intervals. Surveying commenced at profile lines 2 and 3 on Fairfield Beach on 13 November 1962, and surveys were conducted at the same intervals as profile line 1.

Figures 8 to 11 present survey frequency information.

TABLE 1

## SUMMARY OF PROFILE LINE INFORMATION.

PROFILE LINE	CONNECTICUT STATE PLANE COORDINATES OF MONUMENT (ft)		AZIMUTH	DISTANCE BETWEEN ADJACENT MONUMENTS (m)	SURVEY PERIOD	TOTAL NO. OF SURVEYS
	E.	N.				
Myrtle Beach						
1	513161.60	133779.54	114°40'01"	410.5	9 November 1962 - 19 April 1971	54
2	512289.64	132754.20	157°26'20"			
3	511809.32	132626.73	178°51'26"	151.6	20 December 1965 - 16 June 1970	17
4	510321.42	132558.73	159°11'32"	454.3		
Fairfield Beach						
1	465830.28	112660.94	124°14'54"	355.2	13 December 1962 - 20 April 1971	53
2	465133.54	111728.02	114°15'54"			
3	464280.95	109459.66	100°12'40"	739.1	13 November 1962 - 20 April 1971	54

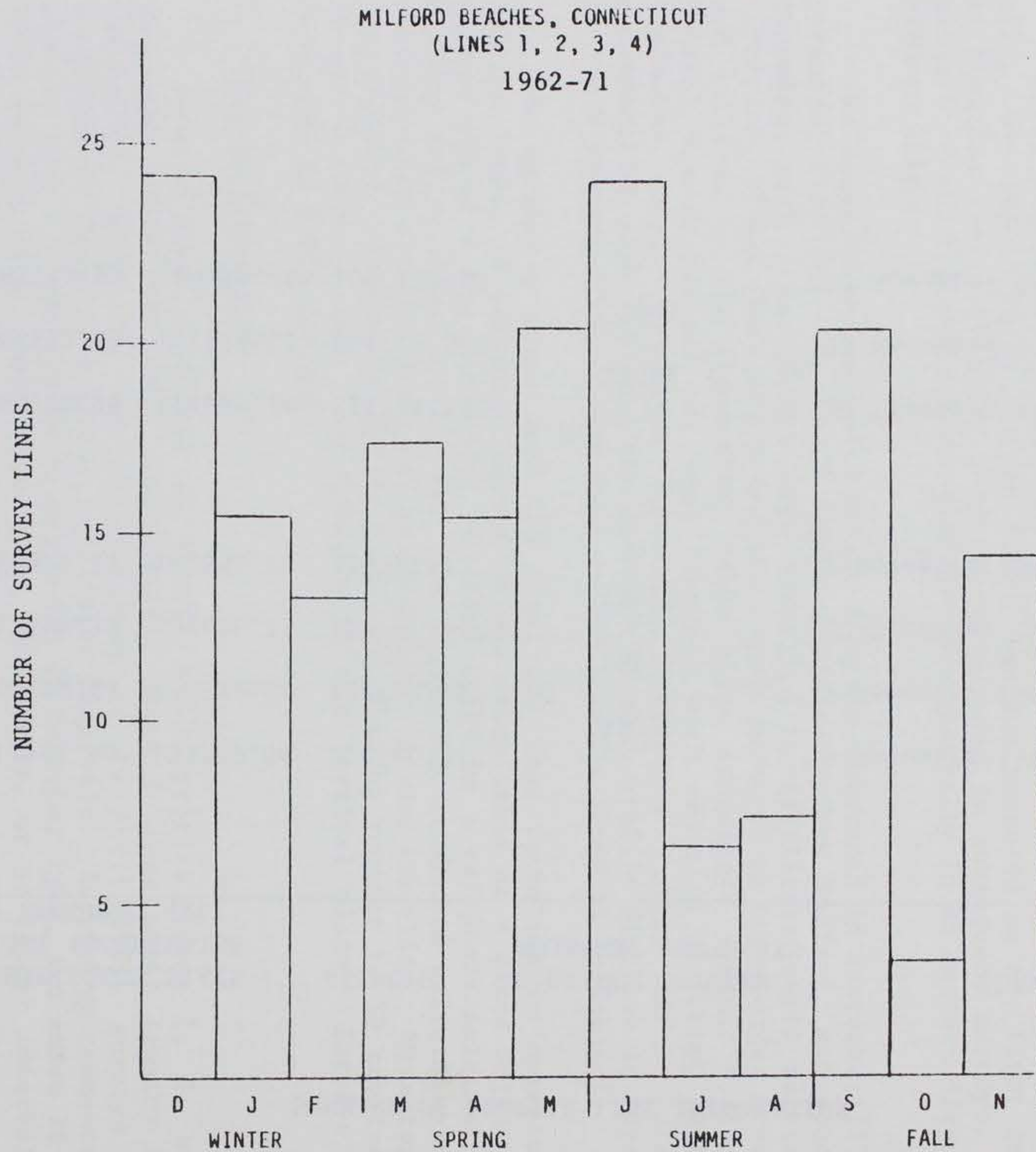

Figure 8. Seasonal survey frequencies for Milford beaches.

MILFORD BEACHES, CONNECTICUT  
(LINES 1, 2, 3)

1962-71

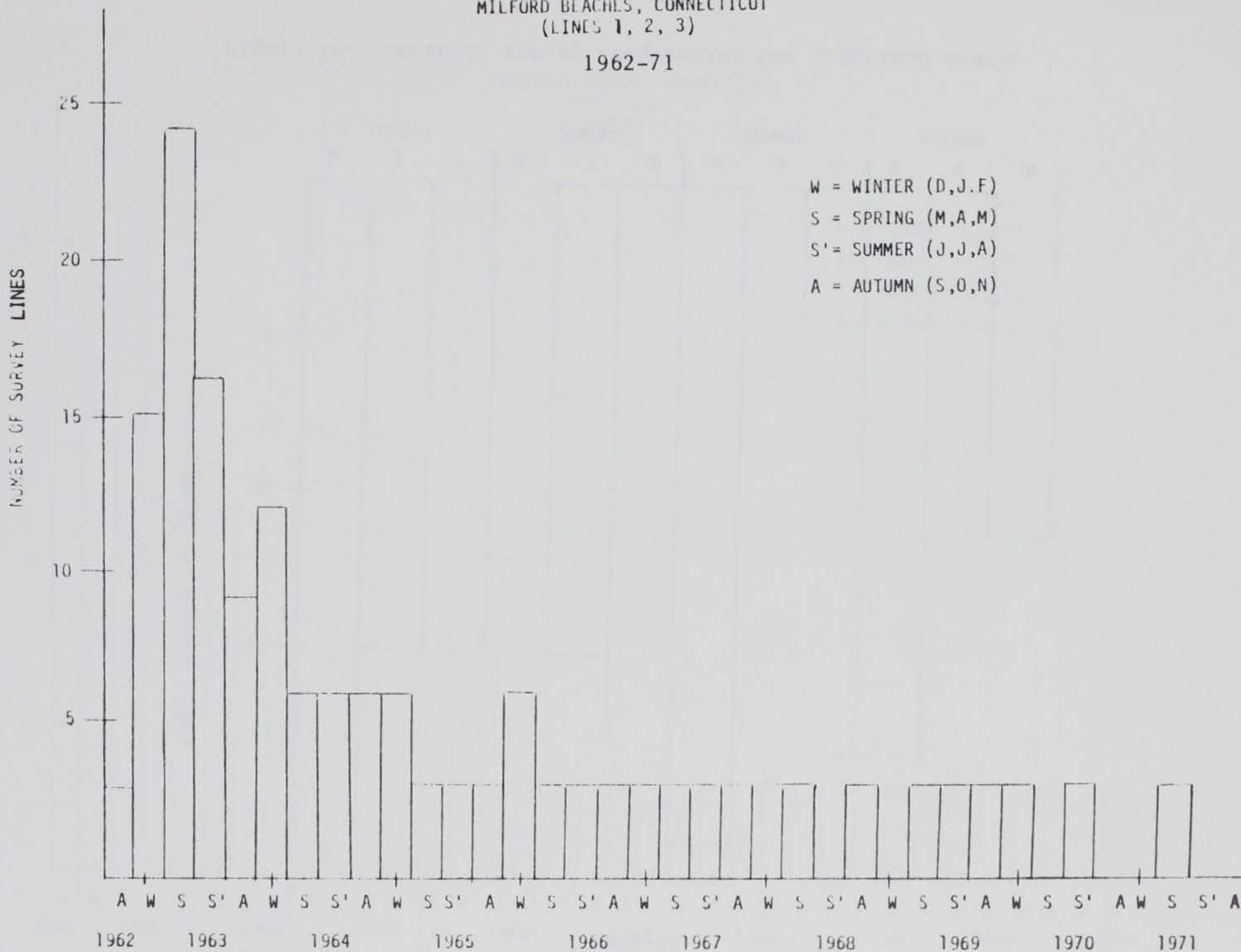

Figure 9. Annual survey frequencies for Milford beaches, Connecticut (lines 1, 2, and 3).

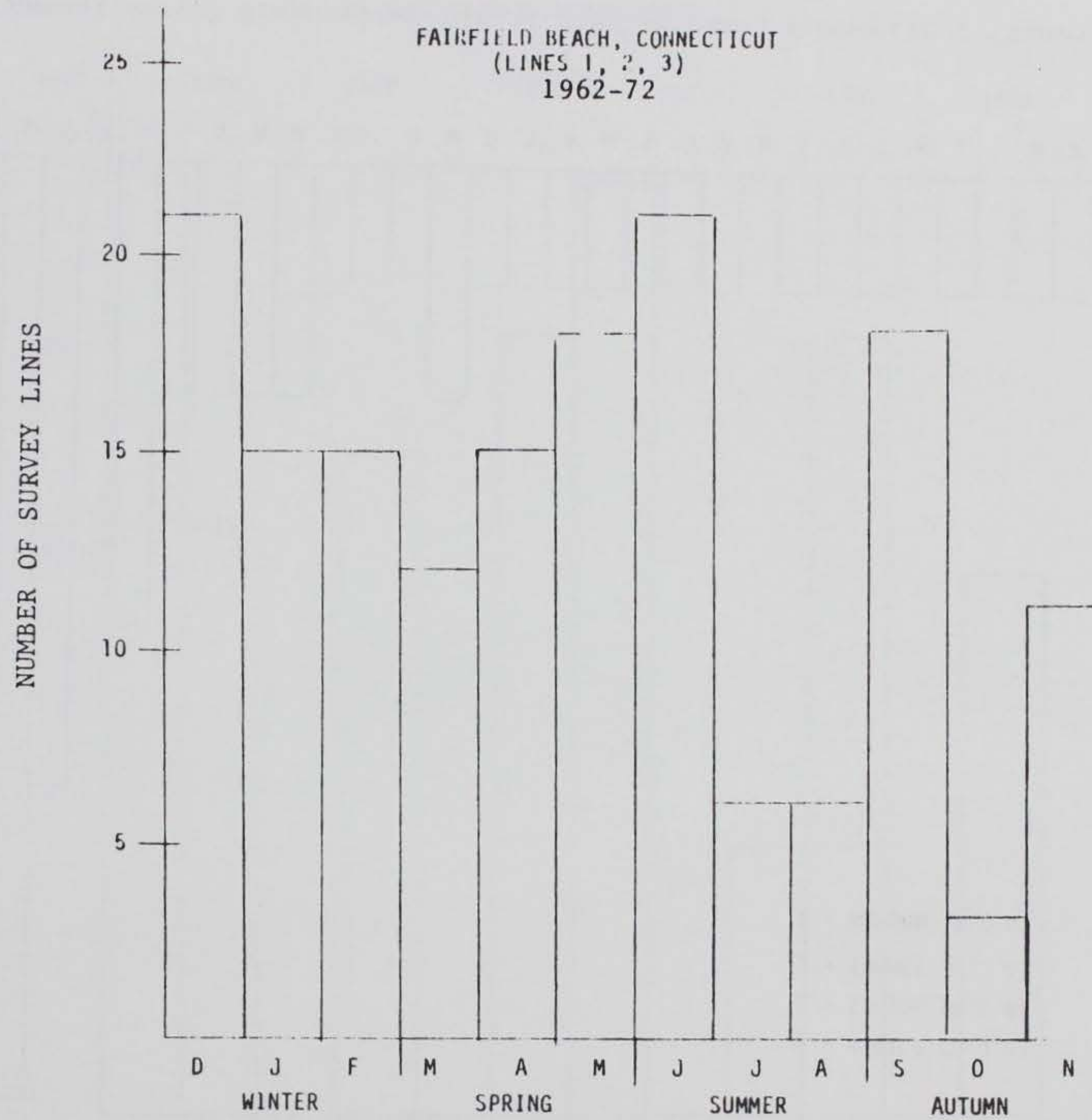

Figure 10. Seasonal survey frequencies for Fairfield Beach.

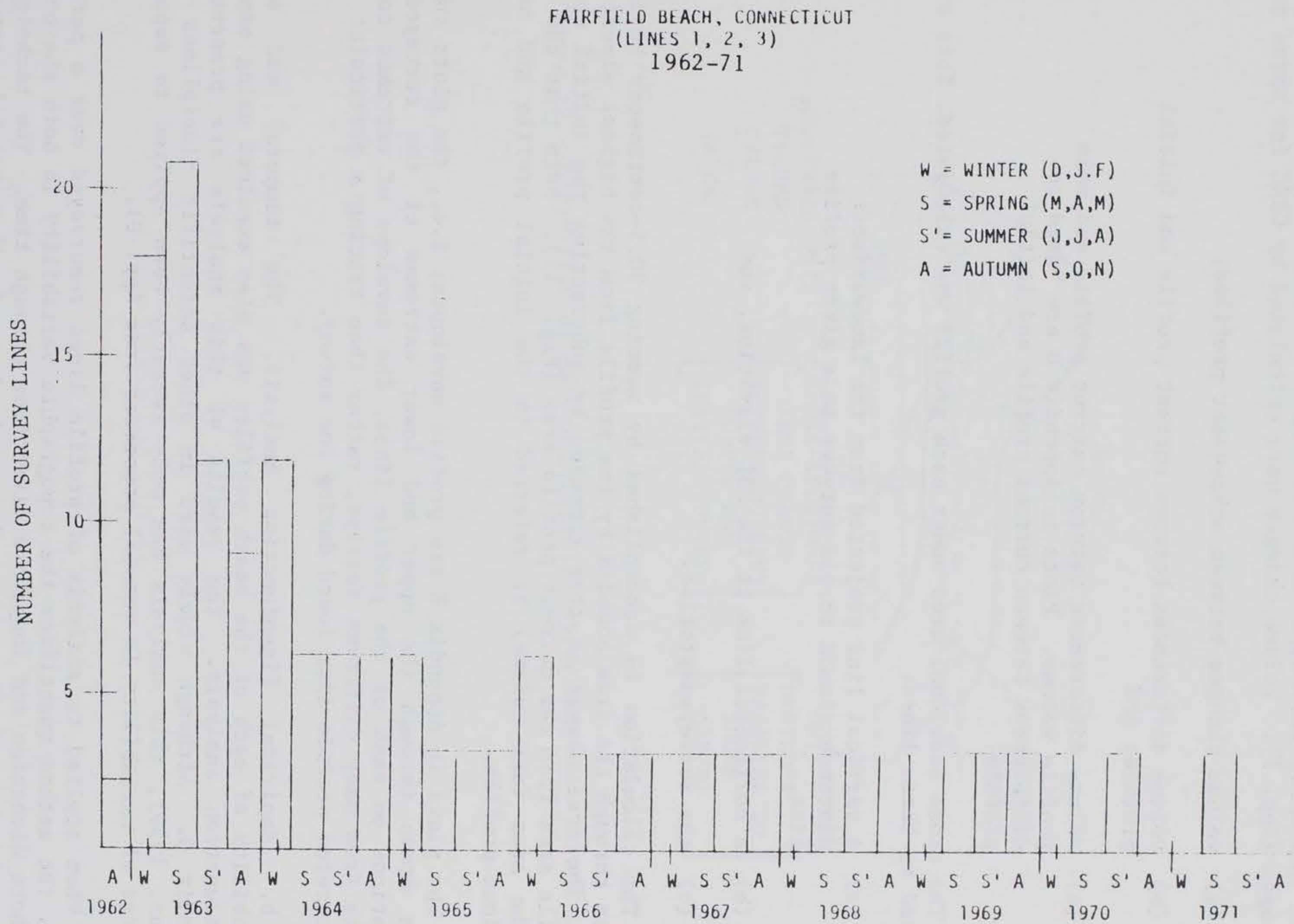

Figure 11. Annual survey frequencies for Fairfield Beach, Connecticut (lines 1, 2 and 3).

### 3. Analytical Procedures.

a. Profile Line Analysis. Profile line surveys were analyzed by CERC, using the Beach Profile Analysis System (Fleming and DeWall, 1982). Computer plots were generated for changes in the above MSL volume (App. D), changes in MSL shoreline intercept from the original survey (App. E), and profile envelopes (App. F). Volume changes were calculated by CERC for three cases:

- (a) volume changes between subsequent profiles;
- (b) volume differences between current profile and initial profile; and
- (c) volume differences between current profile and mean profile volume. Plots in Appendix D are based on differences between current profile and initial profile.

The cross-sectional area under each profile was calculated. This area is defined by three lines:

- (a) A vertical line projected from the landwardmost distance common to all surveys on a given profile line,
- (b) a horizontal line to the MSL elevation, and
- (c) the surveyed profile.

The calculation is accomplished by summing 30.5-centimeter horizontal slices through the area bounded by the profile from the highest elevation to MSL. The area change is then computed by subtracting the initial measured profile area from the current profile area (Fig. 12). Note that the change in the area (and volume) is referred to the initial profile and not the previous profile.

The plots in Appendix E are profile envelopes; i.e., the plots show two lines drawn through the upper and lower extremes of the surveyed sand elevations on each of the profile lines. The envelope of extremes contains points from many different surveys, rather than tracing a particular eroded or accreted profile line found during one survey.

b. Empirical Eigenfunction Analysis. The temporal and spatial variability of each of the beach profiles was also examined using empirical eigenfunction analysis. The results of this analysis are presented in Appendix G. Although widely used in other scientific disciplines (e.g., Lorenz, 1959), this analysis has only recently been applied to separating sources of variability in coastal processes (see App. G).

When applied to analysis of profile lines resurveyed over a period of time, the method quantifies the topographic variability in both the onshore-offshore direction and longshore directions through time. The technique has been applied to studies on beaches, islands, and other coastal features on

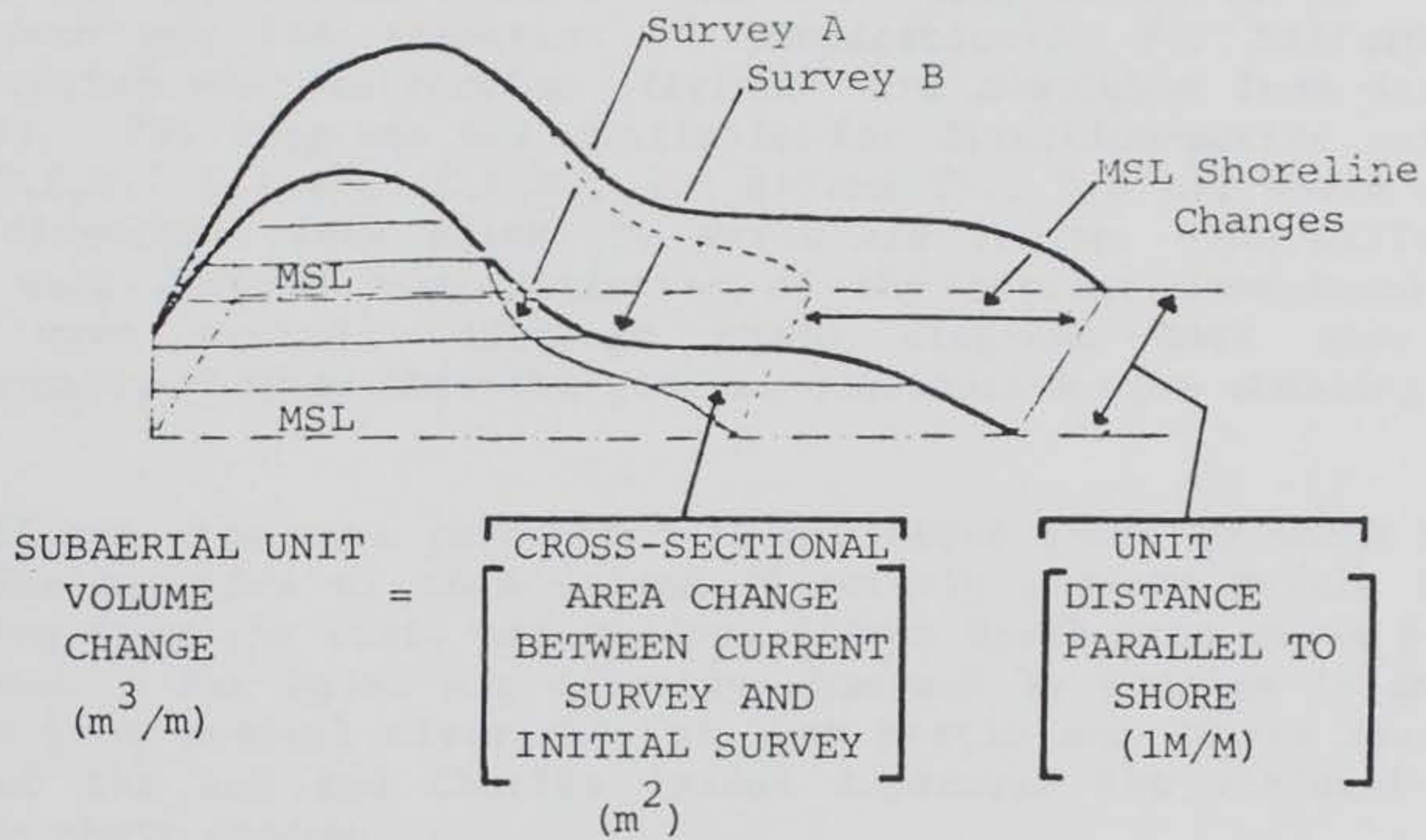

Figure 12. Definition of MSL shoreline and above MSL unit volume change.



both the Atlantic and Pacific coasts (Winant, Inman, and Nordstrom, 1975; Vincent, et al., 1976; Resio, et al., 1977; Aubrey, 1979; Miller, Aubrey and Karpen, 1980; Miller 1983). This technique provides a useful supplement to the more standard analytical procedures described above.

## IV. RESULTS

### 1. Linear Wave Refraction.

In order to obtain a qualitative understanding of the nearshore wave field off the Milford and Fairfield beaches, offshore waves were linearly refracted shoreward using a model developed by Dobson (1967). Input wave parameters include deepwater height, period, and direction, shoaled over a bathymetry approximated by a regular rectangular grid. Based on an assessment of the fetch and duration limitations for the incident wave field, wave refraction diagrams for Fairfield Beach were run for periods of 3, 6 and 9 seconds, at directions from  $75^\circ$  to  $270^\circ$  true north at  $15^\circ$  increments (angles given are the direction of propagation). For Milford beaches, hand-constructed wave refraction diagrams were available from Jacobson, et al. (1981). The diagrams are available for direction-period pairs (S.W., 4.8 s), (S.S.W., 4.9 s), (E.S.E., 5.6 s) and (E., 5.6 s), where angles are given as directions from which the waves are coming. The differences in direction were derived from estimates of the angular dependence of modal energetic wave period. Although these diagrams have some internal inconsistencies, they do show the general qualitative wave shoaling trends at Milford.

At Milford, the wave refraction is dominated close to shore by Charles Island. The presence of this island effectively shadows Myrtle Beach from waves coming from the east, and shadows Silver Beach from waves propagating from the west. For waves not directly shadowed by Charles Island and the bar, there is a general divergence at both Myrtle and Silver Beaches. The presence of the bar and Charles Island separates the littoral transport patterns in their shadow.

Refraction data for Fairfield Beach show a strong bathymetric control on the nearshore wave regime. For waves coming from eastern directions with 6- and 9-second periods, Stratford Shoal affects the shoaling. Closer to shore, the ridge off Shoal Point dominates the refractive behavior of the wave field. Although the interpretation of nearshore wave behavior is somewhat complicated by wave caustics, in general, there is a divergence of wave energy along Fairfield Beach. This divergence is greatest for deepwater angles near  $255^\circ$  and  $90^\circ$ . Examples of the Fairfield refraction diagrams are given in Appendix H. Thus, both beaches show general divergence except where altered by nearshore bathymetry.

### 2. Beach Profile Changes.

a. Long-Term Beach Changes. Three indicators of long-term beach changes are available for Milford and Fairfield, Connecticut, beaches: trends in MSL intercept position over time (App. E), MSL volume (App. D), and beach eigenfunction behavior (App. G).

(1) Mean Sea Level Intercept. Table 2 lists the regression statistics for MSL intercept trends through time for the Connecticut beaches. Appendix E shows plots of the MSL intercept versus time for these same beaches. Milford beaches show no monotonic trends in MSL intercept position, with the exception of profile line 3 on Myrtle Beach (5 years of data) (App. E). Table 2 supports this observation of gradual erosion, at a rate of 3 meters per year. Profile line 1 experienced a shoreward MSL movement from 1964 to

TABLE 2

REGRESSION COEFFICIENTS  
FAIRFIELD AND MILFORD BEACHES

MILFORD BEACHES

PROFILE	MSL INTERCEPT			MSL VOLUME		
	Slope	Intercept	r <sup>2</sup>	Slope	Intercept	r <sup>2</sup>
1	-2.886m/yr	9.52m	0.165	-1.544	5.1	0.392
2	-0.86	2.86	0.027	-5.868	19.4	0.868
3	-2.964	17.7	0.719	-1.584	9.3	0.766
4	-2.256	-7.4	0.188	- .95	3.12	0.079

FAIRFIELD BEACH

1	0.372	-1.23	0.85	2.4	-8.2	0.752
2	-0.24	0.76	.039	3.43	-11.1	0.869
3	0.099	- .33	.002	-1.8	6.07	0.548

1966, followed by a seaward MSL movement up to 1971 (App. E). This abrupt change in 1966 may possibly have been due to fill or grading operations along the east end of the beach, although there is no supporting documentation for this activity. Profile lines 2 and 4 (App. E) (along Myrtle Beach) show no long-term trends in MSL intercept.

At Fairfield Beach, profile lines 1 and 3 show a definite long-term trend in MSL intercept (App. E). Profile line 1 shows a net yearly seaward transport (accretion) of about 0.4 meter per year, while profile line 3 shows a strong landward migration of about 20 meters in 10 years, superimposed on which are large year-to-year variations. These trends are not supported statistically (Table 2) for any of the three Fairfield beaches. There is no significant trend; in fact the (insignificant) trend in profile line 3 is accretion, not erosion. Thus the results of plotting the MSL intercept do not show a not common trend for all the beaches.

(2) Above MSL Unit Volume Changes. Trends in the volume of sand accreted above MSL through time provide an indication of the long-term beach development (erosion and accretion). Long-term trends in MSL volume changes at the Milford beaches are not evident. A visual examination of the volume plots (App. D) shows net erosion along all four lines, but the plots have definite structure to them. Profile line 1 shows a mean erosion from 1964 to 1971, superimposed by broad fluctuations with a 1-or 2-year period. Profile line 2 (Myrtle Beach) shows rapid erosion between 1962 and 1965, followed by an increase between 1966 and 1968. From 1968 to 1971 there was once again rapid erosion. The accretion in 1966 corresponds to a similar change in the MSL intercept location, suggesting fill operations. Profile line 3 shows a net erosional trend over the course of the survey period, 1966-71. Profile line 4 shows little change from 1963 to 1966, followed by rapid buildup until 1967. The period 1967-71 resulted in rapid erosion. A statistical analysis shows significant erosion at lines 2 (6 cubic meters per year per meter of beach length) and 3 (13 cubic meters per year per meter of beach length) (Table 2). Trends at profile lines 1 and 4 are obscured by the more complex history of change.

Visual scrutiny of plots of MSL volume at Fairfield Beach shows long-term accretion at profile lines 1 and 2, and erosion at profile line 3 (App. D). A statistical analysis supports this observation (Table 2). Profile line 1 underwent a mean annual volume increase of 2.4 cubic meters per year per meter of beach length, while profile line 2 underwent a mean annual increase of about 4 cubic meters per year per meter of beach length. This latter trend is accelerating in later years of the survey. The erosional trend at profile line 3 is not statistically significant, but averages out to about 1.8 cubic meters per year per meter of beach length. It must be emphasized that these numbers are small compared to changes observed along the open ocean coastlines (Miller and Aubrey, 1983; Aubrey, Inman, and Winant, 1980).

There is little agreement in trends between MSL intercept and volume change statistics. Whereas volume changes show definite, significant changes for profile lines along the Connecticut beaches, only one profile line shows a significant trend in the MSL intercept. This dichotomy illustrates the dangers in estimating beach erosion or accretion from a statistic or indicator of beach change (such as MSL intercept) which does not include

information on all parts of the beach. This data set also demonstrates the need for analyzing the time series of beach change, and not the long-term average statistics, when assessing beach response over long time spans.

(3) Beach Eigenfunctions. Tables 3 and 4, along with Appendix G, show long-term beach trends using eigenfunction analysis. Table 3 shows the beach eigenvalues for profiles that retained their mean value, while Table 4 presents eigenvalues for beach changes after removing the arithmetic mean profile from the data set (see App. G for explanation of analysis).

Interpretation of the eigenfunctions at the Milford beaches is difficult. There is no coherent net trend in beach development at profile lines 1 and 4, as indicated by the spatial and temporal mean eigenfunctions (App. G). Profile lines 2 and 3, however, do show a net erosion over the period of the study. Behavior of the demeaned eigenfunctions provides greater detail of long-term beach changes along the Milford beaches. Profile line 1 (Silver Beach) shows erosion of sand from the foreshore slope, and accretion along the backshore (App. G), possibly indicative of fill or grading. Profile line 2 (Myrtle Beach) shows erosion of sand over the entire profile, with most sand eroded along the backshore area (Bench mark +25 meters). Profile line 3 shows erosion of sand over most of the profile, with an exception close to the MSL position. Profile line 4 shows erosion of sand near the berm and very slight accretion toward either side. Table 4 lists the trends in beach development as depicted by eigen functions.

Beach eigenfunctions at Fairfield Beach show trends in profile development very effectively (App. G). Both mean spatial and temporal eigenfunctions at profile line 1 show a small increase in sand volume over the period of study (App. G). Profile lines 2 and 3 (App. G) also show a net increase over the entire profile (first mean eigenfunction), but a mixed trend in the onshore or offshore sense for the second function.

To better evaluate these long-term trends, the demeaned eigenfunctions can be examined (the arithmetic mean profile has been subtracted from each respective data set prior to analysis; see App. G). These demeaned eigenfunctions show the distinct accretion at profile lines 1 and 2, and erosion over most of profile line 3. Statistics for these changes are in Table 4.

The trends indicated by the eigenfunction analysis correlate well with trends observed from plots of MSL volume. The eigenfunctions, however, are more useful because the different portions of the beach are shown with relation to other portions along the same profile. It is this retention of detail and spatial description that makes eigenfunctions so useful. indent [-5]

b. Seasonal Beach Changes. Seasonal beach changes along Fairfield and Milford beaches are almost completely absent, based on an analysis of profile data using the MSL intercept, MSL volume, and eigenfunction techniques. The only indication of seasonality is shown in profile line 3 at Myrtle Beach, and is best illustrated by the time variation of the first demeaned eigenfunction (App. G). In this instance, superimposed on a gradual erosional trend, a marked slope change is associated with the beginning of each calendar year (winter-storm response). This signal is weak compared with the long-term trends, which are themselves weak.

TABLE 3

MEAN BEACH EIGENFUNCTIONS  
FAIRFIELD AND MILFORD BEACHES

MILFORD BEACHES

<u>PROFILE</u>	<u>MSV</u> (m <sup>2</sup> )	<u>1</u>		<u>2</u>		<u>3</u>		<u>4</u>	
		% total (MSV)	% total (MSV)	% residual	% total (MSV)	% residual	% total (MSV)	% residual	
1	1.74	98.88	0.72	64.0	0.10	8.9	0.08	6.8	
2	1.82	98.50	1.03	69.0	0.19	12.6	0.19	5.7	
3	0.35	98.37	0.81	49.6	0.49	30.4	0.13	8.1	
4	3.31	99.19	0.55	68.5	0.11	13.5	0.05	6.0	

FAIRFIELD BEACH

1	12.00	99.87	0.10	78.1	0.01	9.2	0.01	5.1
2	5.63	99.67	0.15	47.0	0.08	25.3	0.05	13.9
3	2.67	99.47	0.24	45.9	0.07	14.2	0.07	13.2

TABLE 4

DEMEANED BEACH EIGENFUNCTIONS  
FAIRFIELD AND MILFORD BEACHES

<u>PROFILE</u>	<u>MSV</u> (m <sup>2</sup> )	<u>MILFORD BEACHES</u>			
		<u>1</u> % total (MSV)	<u>2</u> % total (MSV)	<u>3</u> % total (MSV)	<u>4</u> % total (MSV)
1	0.020	62.2	8.5	6.9	5.6
2	0.084	86.3	5.9	2.4	1.8
3	0.008	61.0	21.6	6.7	4.1
4	0.029	68.8	13.0	5.6	2.8
		<u>FAIRFIELD BEACH</u>			
1	0.022	79.3	8.7	4.0	3.8
2	0.034	69.0	14.3	8.2	3.6
3	0.018	51.2	12.3	10.2	7.8

Miller and Aubrey (1983) have shown where the variances in beach profile data are a useful measure for intercomparison of the profile responses at different beaches. On the Connecticut beaches, the variance is shown by the mean square value (MSV) for demeaned eigenfunctions (Table 4)--values for Myrtle Beach range from 0.008 to 0.084 square meter with an average value of 0.040 square meter. The MSV for profile line 1 at Silver Beach is 0.020 square meter. Values for Fairfield Beach have an average of 0.025 square meter, with a smaller range. These values are one order of magnitude lower than those for the open ocean beaches. Cape Cod, Massachusetts beaches have a MSV of 0.5 square meter, while southern California beaches have a MSV of 0.2 square meter. This emphasizes the small changes undergone by protected Connecticut beaches as compared with those along less sheltered coasts.

c. Short-Term Changes. The profile data obtained along Fairfield, Myrtle, and Silver Beaches over the period 1962-71 display persistent, small magnitude, short-term variability. The extent and sense of these variations fluctuates significantly over space and time. All beaches experience aperiodic occurrences of both erosion and accretion. The lack of a dominant trend suggests that sediment transport in the vicinity of each beach is not dominated by a single transport factor, but rather is more or less equally influenced by winds, wind waves, and tidal currents. The impact of high energy storm events passing over the area appears to be effectively reduced by the combination of shore front orientation, nearshore bathymetry, and the sheltering provided by Long Island and more proximate shoals and headlands. Several of the surveys conducted during the first 14 months of the project illustrated this limited and spatially variable response (see App. G). After this time the decreased survey frequency precludes resolution of storm response. The data provide, at best, indications of monthly to seasonal trends. These lower frequency characteristics are discussed in more detail in the following sections.

Western Long Island Sound, in the vicinity of Fairfield and Milford, is affected by two primary storm types: the tropical storm, and the more common coastal storm. The impact of these storms on the study areas depends primarily on the intensity of the individual event and its trajectory or track line and the antecedent beach conditions. For storms of equal intensity, the orientation of the beaches and local sheltering characteristics favor maximum impact from those events producing winds rich in southerly and easterly components. Such events would tend to proceed along a northeasterly track to the south of Long Island. Several such events occurred during 1962-63.

(1) Storm of 28-29 October 1963. - Hurricane Ginny. This wandering tropical storm was initially formed in the southern north Atlantic and migrated to the north and west, impacting the east coast of the United States, first in the vicinity of Cape Hatteras on 20 October 1963. In this position it initially stalled, then intensified to hurricane strength, and subsequently began a slow southerly drift toward Florida. On 24 October, located just offshore of the Florida-Georgia border, the hurricane reversed course and began a north-northeasterly track back toward Cape Hatteras. Passing Hatteras on 27 October, it veered slightly to the east and proceeded to migrate toward the Canadian Maritimes. The center of this storm, with a barometric pressure of 980 millibars, passed south of Long Island during 28-29 October, producing easterly winds and rain. The impact of the storm was reduced to some extent within western Long Island Sound by the intrusion



of a high-pressure system that forced the center slightly offshore and favored generation of westerly to southwesterly winds. Despite this blocking, the area did experience a period of easterly winds prior to the frontal passage.

Analysis of shore front profiles for the period 23 October to 27 November 1963 indicated relatively minor variations in beach contour. On Silver Beach, erosion dominated with approximately 2 cubic meters per meter of beach length eroded over the month. To the southwest, along Myrtle Beach, slight accretion was observed. The rates and trends, however, are not substantially different from those observed during preceding nonstorm intervals and the effect of the storm passage, therefore, must be considered slight.

The Fairfield Beach area experienced accretion in the vicinity of profile line 1 and erosion adjacent to profile lines 2 and 3. On the average the beach front eroded during this period at a rate of approximately 1 cubic meter per meter of beach length. The observed rates and trends are substantially different from those observed during the preceding sampling period, suggesting that the impacts are primarily related to storm passage.

(2) Storm of 29-30 November 1963. This intense coastal storm was produced by the passage of a low-pressure system that formed initially along a gulf coast front, moved inland over the State of Louisiana and continued along a northeast trending track over Chesapeake Bay. The low, averaging pressures of 972 millibars, merged with a second system initially formed over the Great Lakes, and the combined depression moved northeastward into Canada. The track of this system caused the center of the low to pass close by the western Long Island Sound area on the night of 29-30 November. By 2 December the storm was well to the north and its influence on local winds became negligible.

Winds observed at Bridgeport for the period 16 November through 16 December 1963 (Fig. 13) indicated that the advance of the low-pressure center and retreat of a preceding high favored generation of northeasterly winds within western Long Island Sound beginning on 29 November. As the low approached, winds shifted progressively through the east to the southeast. Frontal passage caused the winds to shift to the southwest on 30 November and eventually into the northwest on 1 December. The southwesterlies displayed the maximum sustained speeds for the period.

On the Milford beaches, surveys conducted on 4 December indicate that over the period 27 November through 4 December accretion occurred in the vicinity of profile line 1, erosion on profile line 2, and slight accretion on profile line 4. Accretional rates on profile lines 1 and 4 were approximately the same (0.8 cubic meter per meter). The erosion rate on profile line 2 was substantially higher (approximately 5 cubic meters per meter) resulting in a net erosion of materials from the shore front at a rate of approximately 2 cubic meters per meter. Again these trends contrast with those displayed during the passage of Hurricane Ginny in October 1963. In addition, trends differ substantially from those observed during the subsequent survey period 4-23 December. During this latter period, Silver Beach experienced erosion at a rate of approximately 4 cubic meters per meter, while Myrtle beach accreted in the vicinity of profile line 2 (3 cubic meters per meter) and eroded adjacent to profile line 4 (-2 cubic meters per meter). When viewed

WIND VECTOR PLOT FOR BRIDGEPORT, CONNECTICUT  
14 NOVEMBER - 16 DECEMBER 1963

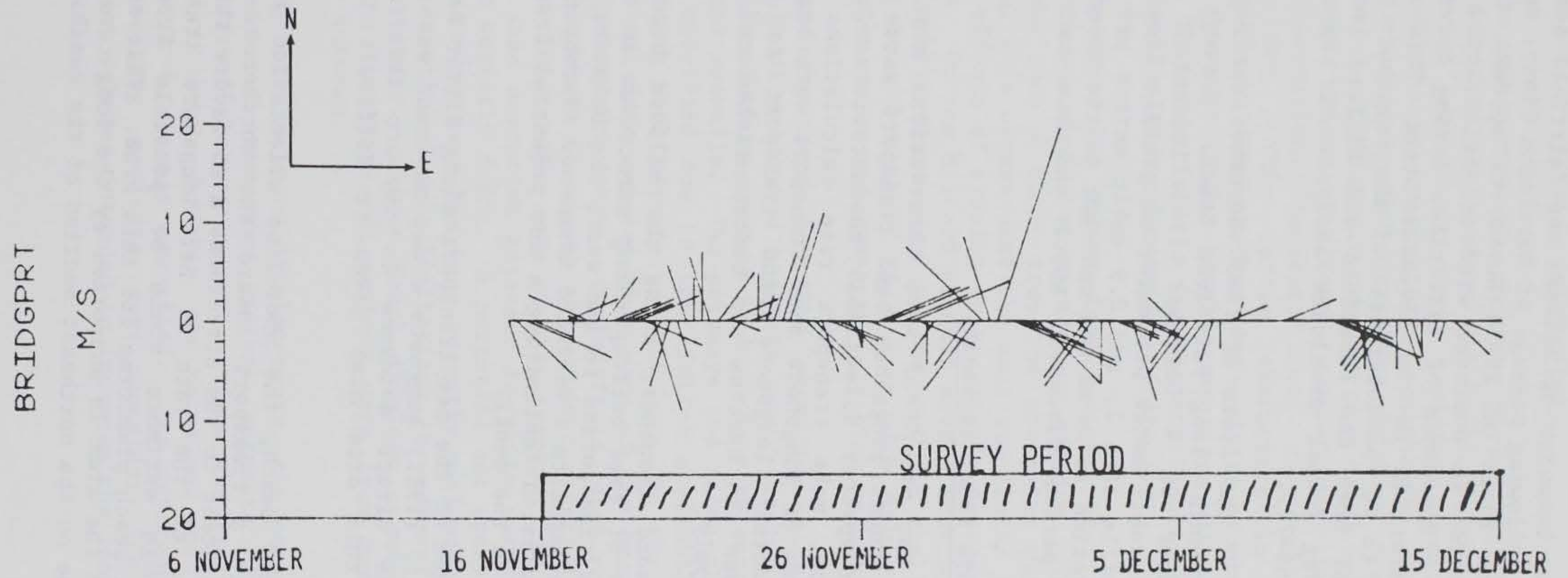

Figure 13. Wind vector plot for Bridgeport, Connecticut.

in combination, the behavior of Milford and Fairfield Beaches, the differing response observed following passage of Hurricane Ginny, as compared with that observed after the storm of 29-30 November, appears to be primarily the result of differences in dominant wind direction. The apparent transport directions imply a dominance of easterlies during Hurricane Ginny and the prevalence of westerlies in the November storm. This sensitivity to wind direction appears to be characteristic of the transport system governing the shape and form of both the Fairfield and Milford beaches, although the infrequent sampling format precludes analysis of beach response to later storm systems (1964-72).

The passage of the storm of 29-30 November was accompanied by general accretion of sediments along Fairfield Beach. Surveys conducted over the period 27 November to 4 December 1963 indicated accretion rates of approximately 0.1 cubic meter per meter on profile line 1, 2.4 cubic meters per meter on profile line 2, and 2.9 cubic meters per meter along profile line 3. This accretion is in marked contrast to the trend observed during the preceding storm period discussed above and its cause cannot be simply specified.

### 3. Longshore Sand Transport.

Because of the nature of wave observations available in this area, calculations of annual longshore sand transport rates were not made. The uncertainty in deepwater directional characteristics, as well as complex shoaling patterns, make transport rate calculations highly speculative. Instead, estimates of longshore sand transport were based on indirect lines of evidence. Actual longshore sand transport is less than potential transport, because the beaches are undernourished and at times starved of adequate sand supply.

Longshore sand transport along the Milford beaches is difficult to imply. Patterns of sand buildup along structures in the Myrtle Beach area suggest sand was transported to the west; the behavior of the beach fill in this region also supports a westward movement. Jacobson, et al., (1981) came to the same conclusion (estimating a net potential transport of 29835 cubic meters annually to the west).

The direction of the net transport along Silver Beach is less apparent. Jacobson, et al., (1981) suggests a net movement was to the west, although there is little direct evidence to support this claim. The lack of structures in this area also makes it difficult to estimate rates of transport.

At Fairfield Beach, the shoreline orientation for the incident wave direction favors a transport toward the northeast. The pattern of sand accumulation adjacent to the structures also favors this interpretation. No direct estimate of the rate of net longshore transport is available, although a rough estimate would be possible from prenourishment and postnourishment beach planforms for this area. That net longshore transport is occurring in the area is supported by the long-term accretional trends in the profile line on the northeast section of the beach.

## V. DISCUSSION

Reviews of the BEP survey data for the period 1962-71 indicate that, in common with most Connecticut beaches, Fairfield, Silver, and Myrtle Beaches are characterized by persistent, small amplitude erosion-accretion cycles displaying limited seasonal variability. Although low frequency sampling during most of the survey period precludes detailed resolution of response characteristics, the available data suggest that beach behavior is consistent with that expected within sheltered, relatively low energy systems. Moreover, the observations indicate that each of these beaches is functionally distinct. This latter characteristic is of particular significance along the Milford beaches where siting of profile line 1 east of the bar on Silver Beach precludes simple comparison with profile lines 2 to 4 west of the bar. The comparison is further complicated by the presence of a groin located along the landward terminus of the bar.

Over the long term, the survey data indicate that each of the Milford beaches is experiencing slow, but persistent erosion. Two of the Fairfield Beach profile lines show a clear trend of accretion while the third shows pronounced erosion. This occurs near the southern limits just to the north of Shoal Point. The effects of erosion progressively decrease with the distance north of this area. On the Milford beaches severe erosion is confined to the eastern limit of Myrtle Beach just to the west of the bar. Erosion rates decrease to the east and west of this area with Silver Beach to the east displaying the lowest rates and comparatively high stability.

The observed long-term trend favoring shoreline erosion appears to be primarily the result of a limited sediment supply acting in combination with constraints in beach mobility imposed by high density shore-front housing and associated roads and seawalls. The pathways and rates of sediment transport cannot be simply specified due to the limited availability of time-series profile data extending both onshore and offshore and the absence of detailed wave data. Historical data suggest that each of the beaches is affected to some extent by longshore transport. On Fairfield Beach shoreline orientation favors northeast longshore transport and evident material accumulations near the entrance to Ash Creek. The rate of this transport is unknown. On Myrtle Beach patterns of sand accretion adjacent to shore perpendicular structures suggest a dominant westerly drift. A potential net annual transport rate of 29835 cubic meters to the west has been recently estimated (Jacobson, et al., 1981). Actual rates will, due to limitations in sediment supply, tend to be lower than this estimate. Silver Beach displays a somewhat more variable degree of longshore transport. Directions vary from east to west and the ultimate rates are unknown.

In addition to longshore sediment displacements, the persistence of erosion, despite the presence of numerous groins, suggests that each beach is influenced by onshore-offshore transport. Given the limited availability of historical bathymetric data, however, the rates and most probable routes of this transport cannot be simply specified. Its apparent presence suggests that future engineering projects must consider its magnitude before attempting to develop schemes intended to increase the long-term stability of any of these beaches.

The characteristics displayed by the Connecticut beaches differ substantially from those displayed on other, less sheltered beaches surveyed as part of the BEP program. In particular, when compared to the Rhode Island (Morton, et al., 1983) or Cape Cod (Miller and Aubrey, 1983) beaches, Fairfield, Myrtle, and Silver Beaches appear relatively stable and dominated by long-term trends. This perception, however, is at least in part an artifact of the low survey frequency employed. Reviews of higher frequency data provided during the initial 14 months of the survey suggest that each of the Connecticut beaches displayed measurable high frequency variability. The observed variations were small in magnitude, however, and often approached the resolution of the survey procedures. In addition, these variations appeared to display a high degree of spatial and temporal variability with response characteristics apparently quite sensitive to wind direction.

## LITERATURE CITED

- AUBREY, D.G., "Statistical and Dynamical Prediction of Changes in Natural Sand Beaches," unpublished Ph.D. Dissertation, University of California, San Diego, Calif., 1978.
- AUBREY, D.G., "Seasonal Patterns of Onshore/Offshore Sediment Movement," *Journal of Geophysical Research*, Vol. 84, No. C10, Oct. 1979, pp. 6347-6354.
- AUBREY, D.G., INMAN, D.L., and WINANT, C.D., "The Statistical Prediction of Beach Changes on Southern California," *Journal of Geophysical Research*, Vol. 85, 1980, pp. 3264-3267.
- BLOOM, A.L., "Coastal Geomorphology of Connecticut," Office of Naval Reserve, Geography Branch, Final Report, No. NONR-401(45), 1965.
- BOKUNIEWICZ, H.J., et al., "Field Study of the Effects of Storms on the Stability and Fate of Dredged Material in Subaqueous Disposal Areas," Technical Report No. D-77-22, U.S. Army Engineer Waterways Experiment Station, Vicksburg, Miss., 1977.
- BOWMAN, D., "Efficiency of Eigenfunction for Discriminant Analysis of Subaerial Non-tidal Beach Profiles," *Marine Geology*, Vol. 39, Feb. 1981, pp. 243-258.
- CZERNIAK, M.T., "Documentation of CERC Beach Evaluation Program Beach Profile Line Locations at Fairfield Beach and Myrtle Beach, CT," Coastal Processes Branch, U.S. Army Coastal Engineering Research Center, Fort Belvoir, Va., 1974.
- DOBSON, R.S., "Some Applications of a Digital Computer to Hydrolic Engineers Problems," TP-80, Stanford University, Department of Civil Engineering, Palo Alto, Calif., 1967.
- EVERTS, C.H., "Beach Profile Changes on Western Long Island," *Coastal Geomorphology*, Ch. 13, State University of New York, Binghamton, N.Y., 1978, pp. 279-301.
- FLEMING, M.V. and DeWall, A., "Beach Profile Analysis System (BPAS)," Technical Report 82-1, U.S. Army, Corps of Engineers, Coastal Engineering Research Center, Fort Belvoir, Va., June 1982.
- FLINT, R.F., "The Glacial Geology of Connecticut," *Connecticut Bulletin of the Geology and Natural History Survey*, No. 49, 1930.
- GALVIN, C.J., "CERC Beach Evaluation Program: Background," U.S. Army, Corps of Engineers, Coastal Engineering Research Center, Fort Belvoir, Va., unpublished, 1969.
- HAYDEN, B.P., and SMITH, W., "Season to Season Cyclone Frequency Prediction," *Monthly Weather Review*, Vol. 110, 1982.

- HICKS, S.D., "Long Period Variations in Secular Sea Level Trends," *Shore and Beach*, Vol. 36 No. 1, 1968, pp. 32-36.
- HICKS, S.D., "On the Classification and Trends of Long Period Sea Level Series," *Shore and Beach*, Vol. 40 No. 1, 1972, pp. 20-23.
- JACOBSON, N.L., et al., "Study of Shore Erosion and Shore Protection," State of Connecticut, Department of Environmental Protection, Milford, Conn., 1981.
- LORENZ, E.N., "Empirical Orthogonal Functions and Statistical Weather Prediction," Report No. 1, Statistical Forecasting Project, Department of Meteorology, Massachusetts Institute of Technology, Cambridge, Mass., 1959.
- McCABE, R.A., "Beach Behavior, North Shore Long Island Sound," *Journal of Waterways, Harbors and Coastal Engineering Division*, Vol. 96, No. WW4, 1970, pp. 781-794.
- MILLER, M.C., "Beach Changes at Holden Beach, North Carolina, 1970-74," U.S. Army, Corps of Engineers, Coastal Engineering Research Center, Fort Belvoir, Va. (in preparation, 1983).
- MILLER, M.C., and AUBREY, D.G., "Beach Changes on Eastern Cape Cod, Massachusetts from Newcomb Hollow to Nauset Inlet, 1970-74," U.S. Army, Corps of Engineers, Coastal Engineering Research Center, Fort Belvoir, Va. (in preparation, 1983).
- MILLER, M.C., AUBREY, D.G., and KARPEN, J., "Beach Changes at Long Beach Island, New Jersey, 1962-73," MR 80-9, U.S. Army, Corps of Engineers, Coastal Engineering Research Center, Fort Belvoir, Va., Oct. 1980.
- MORTON, R.W., et al., "Beach Changes at Misquamicut Beach, Rhode Island, 1962-73," U.S. Army, Corps of Engineers, Coastal Engineering Research Center, Fort Belvoir, Va. (in preparation, 1983).
- NATIONAL OCEANIC AND ATMOSPHERIC ADMINISTRATION, "Tidal Current Tables," U.S. Department of Commerce, National Ocean Survey, Rockville, Md., 1975.
- NOBLE, B., and DANIEL, J.W., *Applied Linear Algebra*, 2 ed., Prentice-Hall, Inc., Englewood Cliffs, N.J., 1977.
- RESIO, D.T., et al., "Systematic Variations in Offshore Bathymetry," *Journal of Geology*, Vol. 85, Jan. 1977, pp. 105-113.
- SANDERS, J.E. and ELLIS, C.W., "Geological and Economic Aspects of Beach Erosion Along the Connecticut Coast," *Report of the State Geological and Natural History Survey of Connecticut*, Investigation No. 1, 1961.
- STATE OF CONNECTICUT, "Shoreline Erosion Analysis and Recommended Planning Process," Report No. 29, Department of Environmental Protection, Hartford, Conn., 1979.
- STEINKE, T.J., "Proposal to Rebuild Penfield Reef as a Dredge Spoil Peninsula/Island for the Purpose of Stabilizing the Fairfield, Connecticut Shoreline," Department of Environmental Protection, Hartford, Conn., 1982.

U.S. ARMY ENGINEER DIVISION, NEW ENGLAND, "Beach Erosion Control Report of Cooperative Study of Connecticut, Area 1, Ash Creek to Saugatuck River," Waltham, Mass., 1949.

U.S. ARMY ENGINEER DIVISION, NEW ENGLAND, "Beach Erosion Control Report of Cooperative Study of Connecticut, Area 3, New Haven Harbor to Housatonic River," Waltham, Mass., 1951.

U.S. ARMY ENGINEER DIVISION, NEW ENGLAND, "Hurricane Survey, Fairfield, Connecticut," Interim Report, Waltham, Mass., 1962.

U.S. ARMY ENGINEER DIVISION, NEW ENGLAND, "Hurricane Survey, Stratford, Connecticut," Interim Report, Waltham, Mass., 1963.

VINCENT, C.L., et al., "Systematic Variations in Barrier Island Topography," *Journal of Geology*, Vol. 84, Sept. 1976, pp. 583-594.

WINANT, C.D., INMAN, D.L., and NORDSTROM, C.E., "Description of Seasonal Beach Changes Using Empirical Eigenfunctions," *Journal of Geophysical Research*, Vol. 80, No. 15, May 1975, pp. 1979-1986.



## BIBLIOGRAPHY

- AUBREY, D.G., "A Field Evaluation of a Sea Data Directional Wave Gage," Technical Report 81, Woods Hole Oceanographic Institution, Woods Hole, Mass., 1981.
- AUBREY, D.G., INMAN, D.L., and NORDSTROM, C.E., "Beach Profiles at Torrey Pines, California," *Proceedings of the 15th Conference on Coastal Engineering*, 1976, pp. 1297-1311.
- BALSILLIE, J.H., "Surf Observations and Longshore Current Prediction," TM-58, U.S. Army, Corps of Engineers, Coastal Engineering Research Center, Fort Belvoir, Va., Nov. 1975.
- BIRKEMEIER, W.A., "Beach Evaluation Program Storm Data Summary," U.S. Army, Corps of Engineers, Coastal Engineering Research Center, Fort Belvoir, Va., unpublished, July 1979.
- BRUNO, R.O., and HIIPAKKA, L.W., "Littoral Environment Observation Program in the State of Michigan," *Proceedings of the 16th Conference on Great Lakes Research*, 1973, pp. 492-507 (also Reprint 4-74, U.S. Army, Corps of Engineers, Coastal Engineering Research Center, Fort Belvoir, Va., NTIS 777 706).
- CORNILLON, P.T., "Computer Simulation of Shoreline Recession Rates, Outer Cape Cod," *Environmental Geologic Guide to Cape Cod National Seashore*, S.P. Leatherman, ed., Society of Economic Mineralogists and Paleontologists, Tulsa, Okla., 1979, pp. 91-108.
- CORNILLON, P.T., ISAJI, T., and SPAULDING, M., "Longshore Current; Longshore Energy Flux; Erosion/Accretion," Part II, *Nearshore Wave Climate for the Outer Cape Cod Shore*, Department of Ocean Engineering, University of Rhode Island, Kingston, R.I., 1976.
- DAVIS, W.M., "The Outline of Cape Cod," *Proceedings of the American Academy of Arts and Sciences*, Vol. 31, 1896, pp. 303-332.
- DeWALL, A.E., "Beach Changes at Westhampton Beach, New York, 1962-73," MR 79-5, U.S. Army, Corps of Engineers, Coastal Engineering Research Center, Fort Belvoir, Va., Aug. 1979.
- DeWALL, A.E., PRITCHETT, P.C., and GALVIN, C.J., Jr., "Beach Changes Caused by the Atlantic Coast Storm of 17 December 1970," TP 77-1, U.S. Army Corps of Engineers, Coastal Engineering Research Center, Fort Belvoir, Va., Jan. 1977.
- FELSHER, M., "Beach Studies on the Outer Beaches of Cape Cod, Mass.," unpublished M.S. Thesis, University of Massachusetts, Amherst, Mass., 1963.
- FISHER, J.J., "Regional Geomorphology and Sedimentation, Outer Cape Cod," *Environmental Geologic Guide to Cape Cod National Seashore*, S.P. Leatherman ed., Society of Economic Mineralogists and Paleontologists, Tulsa, Okla., 1979, pp. 55-67.

FISHER, J.J., and LEATHERMAN, S.P., "Stop 10--Highland Light," *Environmental Geologic Guide to Cape Cod National Seashore*, S.P. Leatherman, ed., Society of Economic Mineralogists and Paleontologists, Tulsa, Okla., 1979, pp. 17-19.

GATTO, L.W., "Shoreline Changes Along the Outer Shore of Cape Cod from Long Point to Monomoy Point," CRREL Report 78-17, U.S. Army Cold Regions Research and Engineering Laboratory, Hanover, N.H., July 1978.

GATTO, L.W., "Historical Shoreline Changes Along the Outer Coast of Cape Cod," *Environmental Geologic Guide to Cape Cod National Seashore*, S.P. Leatherman, ed., Society of Economic Mineralogists and Paleontologists, Tulsa, Okla., 1979, pp. 69-90.

KNUTSON, P.L., "Sand Stabilization, Nauset Beach, Massachusetts," *Environmental Geologic Guide to Cape Cod National Seashore*, S.P. Leatherman, ed., Society of Economic Mineralogists and Paleontologists, Tulsa, Okla., 1979, pp. 141-154.

KNUTSON, P.L., "Experimental Dune Restoration and Stabilization, Nauset Beach, Cape Cod, Massachusetts," TP 80-5, Army Corps of Engineers, Coastal Engineering Research Center, Fort Belvoir, Va., Aug. 1980.

KOMAR, P.D., *Beach Processes and Sedimentation*, Prentice-Hall, Inc., Englewood Cliffs, N.J., 1976.

LEATHERMAN, S.P., "Overwash Processes on Nauset Spit," *Environmental Geologic Guide to Cape Cod National Seashore*, S.P. Leatherman, ed., Society of Economic Mineralogists and Paleontologists, Tulsa, Okla., 1979a, pp. 141-154.

LEATHERMAN, S.P., (ed.), *Environmental Geologic Guide to Cape Cod National Seashore*, Society of Economic Mineralogists and Paleontologists, Tulsa, Okla., 1979b.

LYNDE, R.E., "Storm Tides Along the New England Coast," *Proceedings of the Conference on Coastal Meteorology*, Sept. 1976, pp. 88-90.

MARINDIN, H.L., "Encroachment of the Sea Upon the Coast of Cape Cod, Massachusetts, as Shown by Comparative Studies. Cross-sections of the Shore of Cape Cod Between Chatham and Highland Lighthouse," Annual Report, U.S. Coast and Geodetic Survey, 1889, App. 12, pp. 403-407, App. 13, pp. 409-457.

NATIONAL OCEANIC AND ATMOSPHERIC ADMINISTRATION, "Storm Data and Unusual Weather Phenomena," Vol. 14, No. 2, Environmental Data Service, Asheville, N.C., Feb. 1972.

NATIONAL OCEANIC AND ATMOSPHERIC ADMINISTRATION, "Storm Data and Unusual Weather Phenomena," Vol. 15, No. 12, Environmental Data Service, Asheville, N.C., Dec. 1973.

NEUMANN, C.J., et al., "Tropical Cyclones of the North Atlantic Ocean, 1971-1977," U.S. Department of Commerce, National Climatic Center, Asheville, N.C., 1978.

NORDSTROM, C.E., and INMAN, D.L., "Sand Level Changes on Torrey Pines Beach, California," MP 11-75, U.S. Army, Corps of Engineers, Coastal Engineering Research Center, Fort Belvoir, Va., Dec. 1975.

OLDALE, R.N., "Glacial Deposits and Features of Outer Cape Cod," *Environmental Geologic Guide to Cape Cod National Seashore*, S.P. Leatherman, ed., Society of Economic Mineralogists and Paleontologists, Tulsa, Okla., 1979, pp. 41-54.

PAWKA, S.S., et al., "Wave Climate at Torrey Pines Beach, California," TP 76-5, U.S. Army, Corps of Engineers, Coastal Engineering Research Center, Fort Belvoir, Va., May 1976.

PETERSON, K.R., et al., "Criteria for a Standard Project Northeaster for New England North of Cape Cod," Report No. 68, U.S. Department of Commerce, National Hurricane Research Project, Mar. 1964.

PRATT, E., "History of Eastham, Wellfleet, and Orleans, County of Barnstable, Massachusetts from 1644-1844," 1844.

SAVILLE, T., Jr., "North Atlantic Coast Wave Statistics Hindcast by Bretschneider--Revised Sverdrup--Munk Method," TM-55, U.S. Army, Corps of Engineers, Beach Erosion Board, Washington, D.C., Dec. 1954.

SCHALK, M., "A Textural Study of the Outer Beach of Cape Cod, Massachusetts," *Journal of Sedimentary Petrology*, Vol. 8, Aug. 1938, pp. 41-54.

SHEPARD, F.P., *Submarine Geology*, Harper and Row, New York, 1963.

STRAHLER, A.N., *A Geologist's View of Cape Cod*, Natural History Press, 1966.

THOREAU, H.D., *Cape Cod*, W.W. Norton and Company, 1865.

U.S. ARMY ENGINEER DIVISION, NEW ENGLAND, "Cape Cod Easterly Shore Beach Erosion Study," Vols. I, II, and III, Waltham, Mass., 1979.

WINANT, C.D., and AUBREY, D.G., "Stability and Impulse Response of Empirical Eigenfunctions," *Proceedings of the 15th Conference on Coastal Engineering*, American Society of Civil Engineers, 1976, pp. 1312-1325.

ZIEGLER, J.M., HAYES, C.R., and TUTTLE, S.D., "Beach Changes During Storms on Outer Cape Cod, Massachusetts," *Journal of Geology*, Vol. 67, May 1959, pp. 318-336.

ZIEGLER, J.M., TASHA, H.J., and GEISE, G., "Erosion of the Cliffs of Outer Cape Cod: Tables and Graphs," Report No. 64-21, Woods Hole Oceanographic Institution, Woods Hole, Mass., June 1964.

ZIMMERMAN, B., "The Size Analysis of the Sediments of Nauset Harbor, Cape Cod, Massachusetts," unpublished M.S. Thesis, University of Massachusetts, Amherst, Mass., 1963.

## APPENDIX A

### Profile Line Documentation

This appendix provides survey documentation for each of the four profile lines along Myrtle Beach and the three profile lines along Fairfield Beach. The horizontal location of each profile line consists of a monument set by CERC. Each monument is established with reference to local cultural features and the State plane coordinate system. Northing and easting are expressed in feet\*. Vertical control at each profile line consists of a third-order elevation of the top of the monument with respect to the National Geodetic Vertical Datum of 1929. Beach profile measurements were taken along the specified azimuth and extended to a level of -0.6 meter MSL.

---

\* To convert from feet to meters, multiply by 0.3048.

COUNTRY <i>U.S.A.</i>	TYPE OF MARK <i>Con. Mon. with Disc</i>	STATION <i>Profile No. 1</i>	CERC PROFILE	
LOCALITY <i>Milford, Conn.</i>	STAMPING ON MARK <i>48A 48C</i>	AGENCY (CAST IN MARKS) <i>CERC</i>	ELEVATION <i>48A 12.13 M.L.W. 48C 13.14 M.L.W.</i>	
LATITUDE	LONGITUDE	DATUM <i>North America, 1927</i>	DATUM <i>1929 SLD</i>	
(NORTHING) (EASTING) (FT) <i>133,779.54</i>	(EASTING) (NORTHING) (FT) <i>513,161.60</i>	GRID AND ZONE <i>Conn. Lambert</i>	ESTABLISHED BY (AGENCY) <i>CERC</i>	
(NORTHING) (EASTING) (FT) <i>133,897.96</i>	(EASTING) (NORTHING) (FT) <i>512,903.74</i>	GRID AND ZONE	DATE <i>1974</i>	ORDER <i>Third</i>

48A  
48C

TO OBTAIN	GRID AZIMUTH, ADD	TO THE GEODETIC AZIM		
TO OBTAIN	GRID AZ. (ADD)(SUB)	TO THE GEODETIC AZIM		
OBJECT	AZIMUTH OR DIRECTION (GEODETIC)(GRID) (MAGNETIC)	BACK AZIMUTH	GEOD DISTANCE (METERS) (FEET)	GRID DISTANCE (METERS) (FEET)

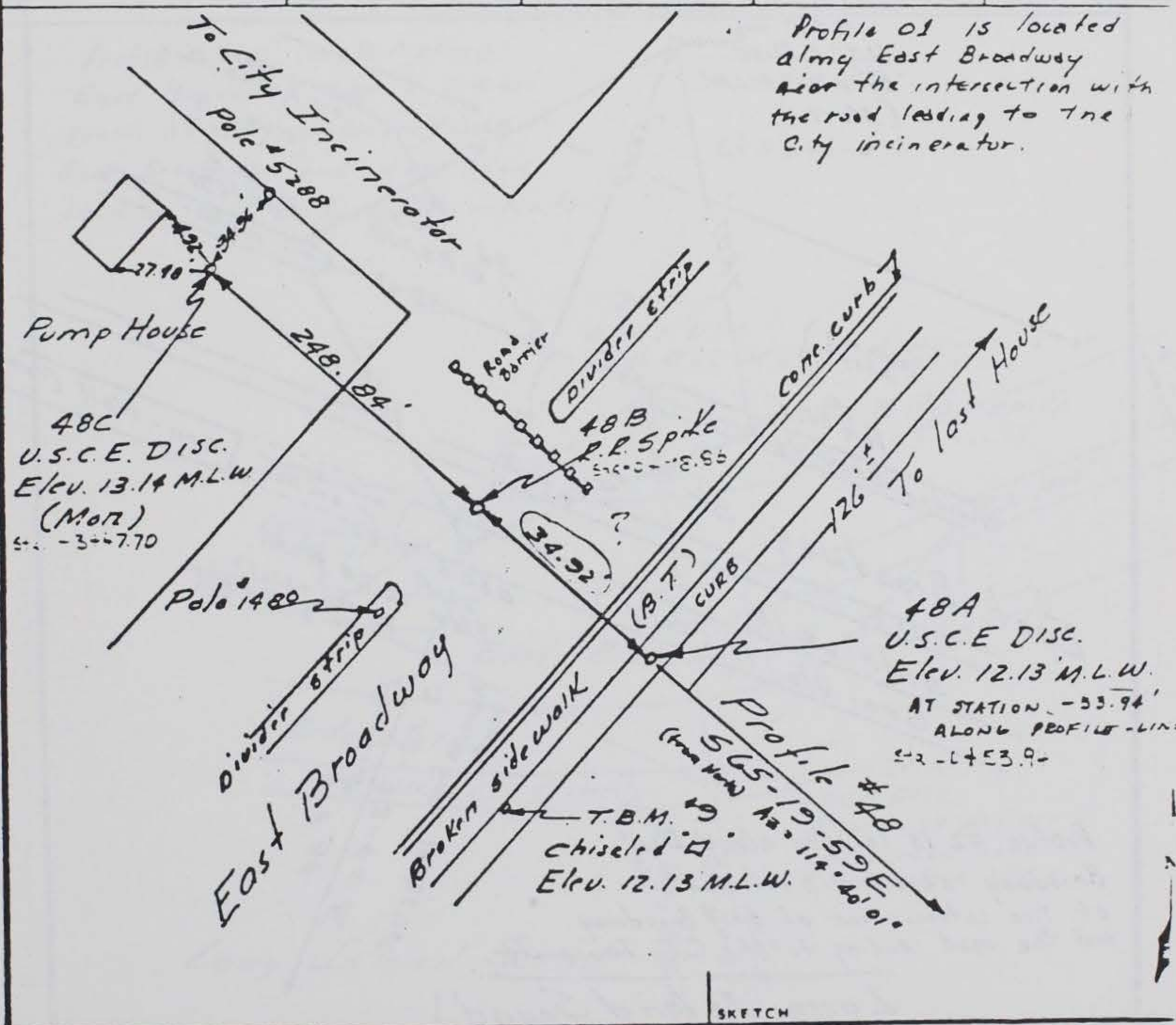

DA FORM 1959 REPLACES DA FORMS 1959 AND 1960, 1 FEB 57, WHICH ARE OBSOLETE. DESCRIPTION OR RECOVERY OF HORIZONTAL CONTROL STATION For use of this form, see TM 5-237, the proponent agency is U.S. Continental Army Command.

COUNTRY U.S.A.	TYPE OF MARK Corr. Mon. with Disc.	STATION Profile No. 2		CERC PROFILE (
LOCALITY Milford, Conn.	STAMPING ON MARK 34A 34C	AGENCY (CAST IN MARKS) CERC	ELEVATION 34A 12.28 MLW 34C 9.17 MLW	
LATITUDE	LONGITUDE	DATUM North America 1927	DATUM 1929 SLD	
(NORTHING: <del>        </del> ) (FT) 34A 132,754.20	(EASTING: <del>        </del> ) (FT) 512,289.64	GRID AND ZONE Conn Lambert	ESTABLISHED BY (AGENCY) CERC	
(NORTHING: <del>        </del> ) (FT) 34C 132,843.18	(EASTING: <del>        </del> ) (FT) 512,252.67	GRID AND ZONE	DATE 1974	ORDER Third

TO OBTAIN	GRID AZIMUTH, ADD	TO THE GEODETIC AZIM
TO OBTAIN	GRID AZ. (ADD/SUB.)	TO THE GEODETIC AZIM

OBJECT	AZIMUTH OR DIRECTION (GEODETIC) (GRID) (MAGNETIC)	BACK AZIMUTH	GEOD DISTANCE (METERS) (FEET)	GRID DISTANCE (METERS) (FEET)

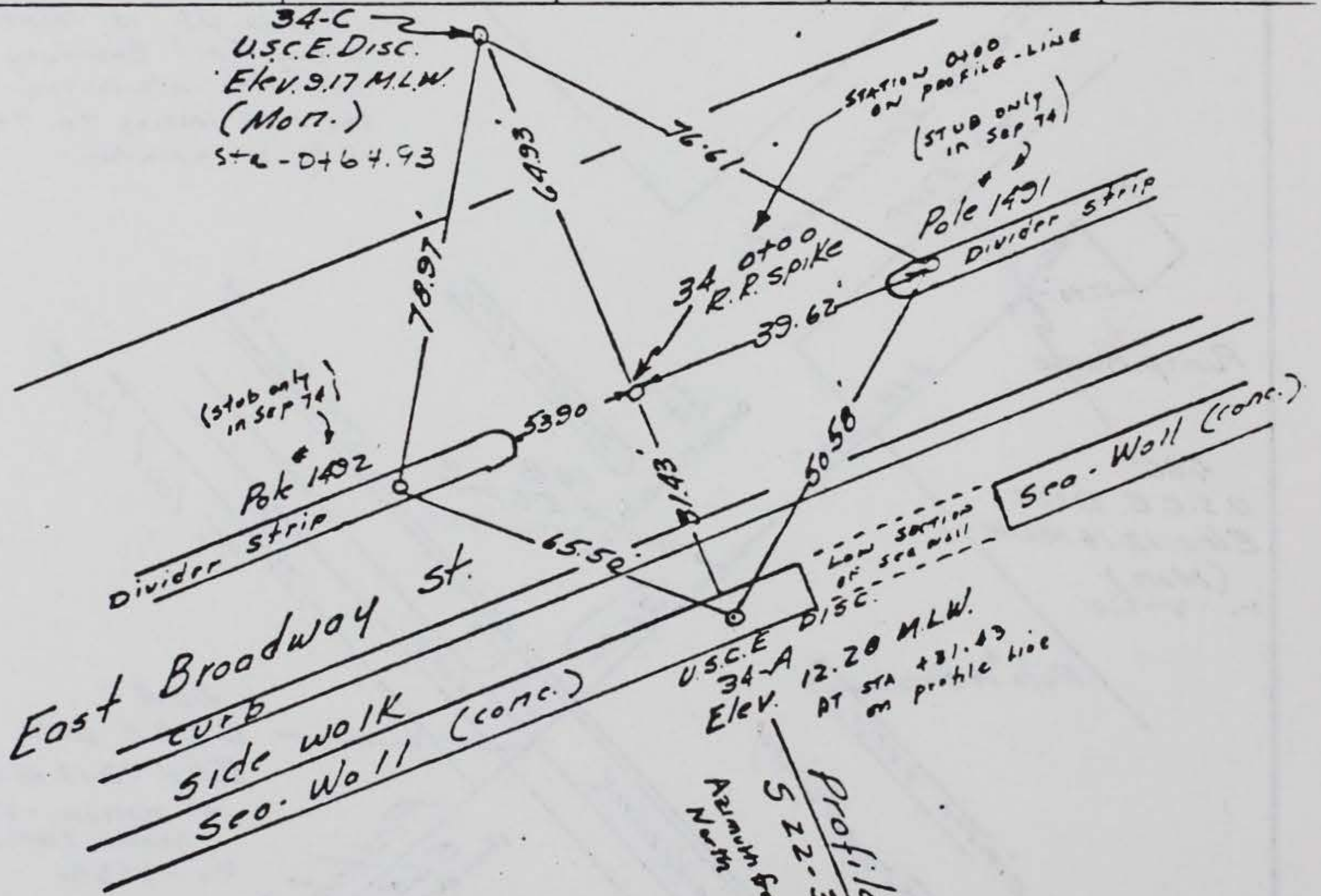

Profile 02 is located along East Broadway about 0.3 mi south of the intersection of East Broadway and the road leading to the City Incinerator

Long Island Sound

SKETCH

DA FORM 1959 1 OCT 64

REPLACES DA FORMS 1959 AND 1960, 1 FEB 67, WHICH ARE OBSOLETE.

DESCRIPTION OR RECOVERY OF HORIZONTAL CONTROL STA

For use of this form, see TM 5-237; the proponent agency is U.S. Continental Army Command.

COUNTRY U. S. A.	TYPE OF MARK Conc. Mon. with Disc.	STATION Profile No. 3	CERC PROFILE	
LOCALITY Milford, Conn.	STAMPING ON MARK 28A 28C	AGENCY (CAST IN MARKS) CERC	ELEVATION 28A 11.93 MLW 28C 8.67 MLW	
LATITUDE	LONGITUDE	DATUM North America, 1927	DATUM 1929 SLD	
(NORTHING) (FT) 132,626.73	(EASTING) (FT) 511,809.32	GRID AND ZONE Conn. Lambert	ESTABLISHED BY (AGENCY) CERC	
(NORTHING) (FT) 132,699.26	(EASTING) (FT) 511,807.87	GRID AND ZONE	DATE 1974	ORDER Thing

28A  
28C

TO OBTAIN	GRID AZIMUTH, ADD	TO THE GEODETIC AZIM.		
TO OBTAIN	GRID AZ. (ADD)(SUB.)	TO THE GEODETIC AZIM.		
OBJECT	AZIMUTH OR DIRECTION (GEODETIC)(GRID) (MAGNETIC)	BACK AZIMUTH	GEOD. DISTANCE (METERS) (FEET)	GRID DISTANCE (METERS) (FEET)

Profile 03 is located along East Broadway, about 0.4 mi south of the intersection of East Broadway and the road leading to the City Incinerator.

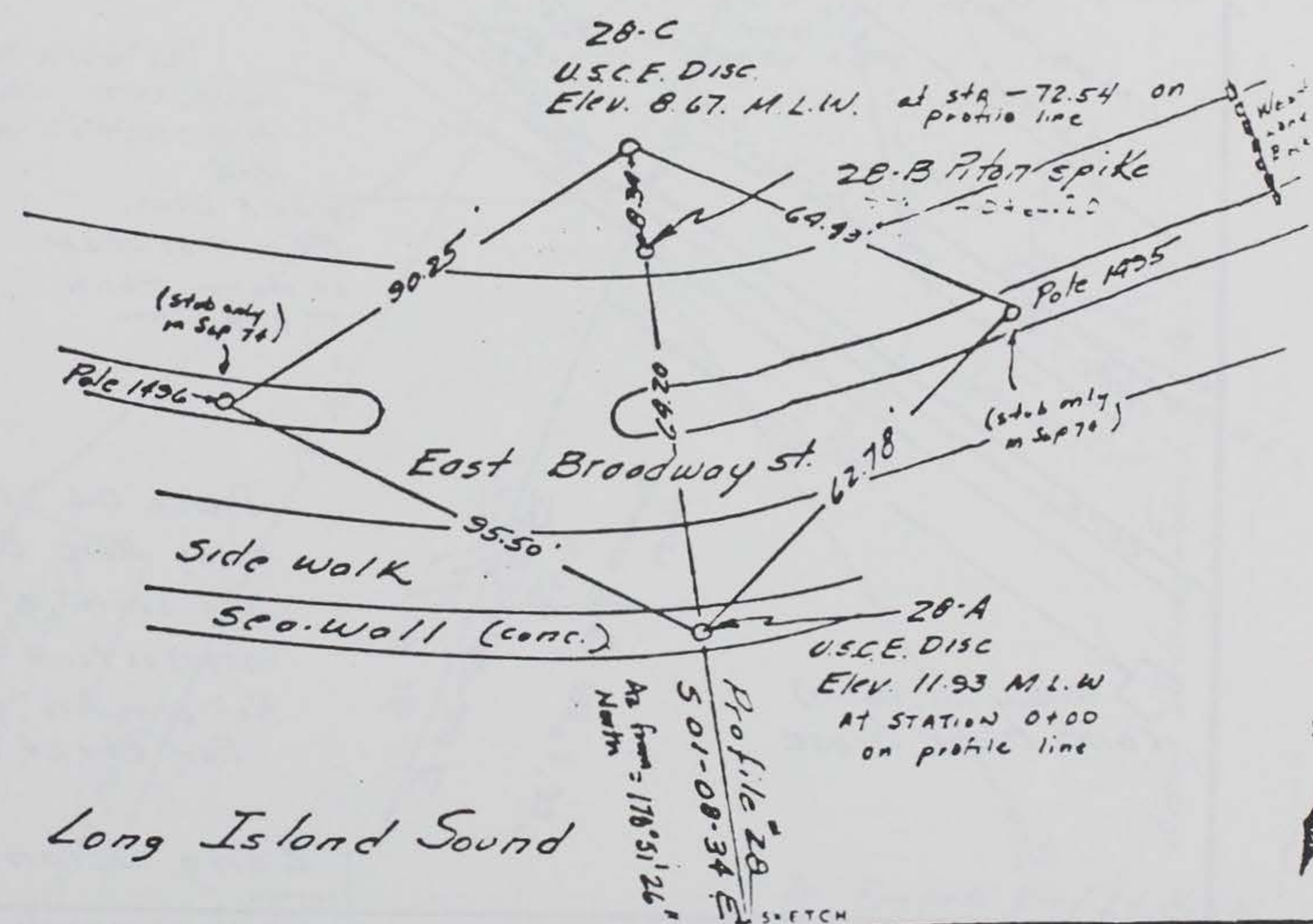

DA FORM 1959

REPLACES DA FORMS 1959 AND 1960, 1 FEB 57, WHICH ARE OBSOLETE.

DESCRIPTION OR RECOVERY OF HORIZONTAL CONTROL STATION  
For use of this form, see TM 5-227, the proponent agency is U.S. Continental Army Command.

COUNTRY <i>U.S.A.</i>	TYPE OF MARK <i>Conc. Mon. with Disc.</i>	STATION <i>Profile No. 4</i>	CERC PROFILE	
LOCALITY <i>Milford, Conn.</i>	STAMPING ON MARK <i>16 A 16 C</i>	AGENCY (CAST IN MARKS) <i>CERC</i>	ELEVATION <i>16 A 11.37 M.L.W. 16 C 11.31 M.L.W.</i>	
LATITUDE	LONGITUDE	DATUM <i>North America, 1927</i>	DATUM <i>1929 SLD</i>	
(NORTHING: <del>XXXXXX</del> ) (FT) <i>16A 132,558.73</i>	(EASTING: <del>XXXXXX</del> ) (FT) <i>510,321.42</i>	GRID AND ZONE <i>Conn. Lambert</i>	ESTABLISHED BY (AGENCY) <i>CERC</i>	
(NORTHING: <del>XXXXXX</del> ) (FT) <i>16C 132,605.52</i>	(EASTING: <del>XXXXXX</del> ) (FT) <i>510,303.64</i>	GRID AND ZONE	DATE <i>1974</i>	ORDER <i>Third</i>

TO OBTAIN	GRID AZIMUTH, ADD	TO THE GEODETIC AZIM		
TO OBTAIN	GRID AZ. (ADD)(SUB.)	TO THE GEODETIC AZIM		
OBJECT	AZIMUTH OR DIRECTION (GEODETIC)(GRID) (MAGNETIC)	BACK AZIMUTH	GEOD DISTANCE (METERS) (FEET)	GRID DISTANCE (METERS) (FEET)

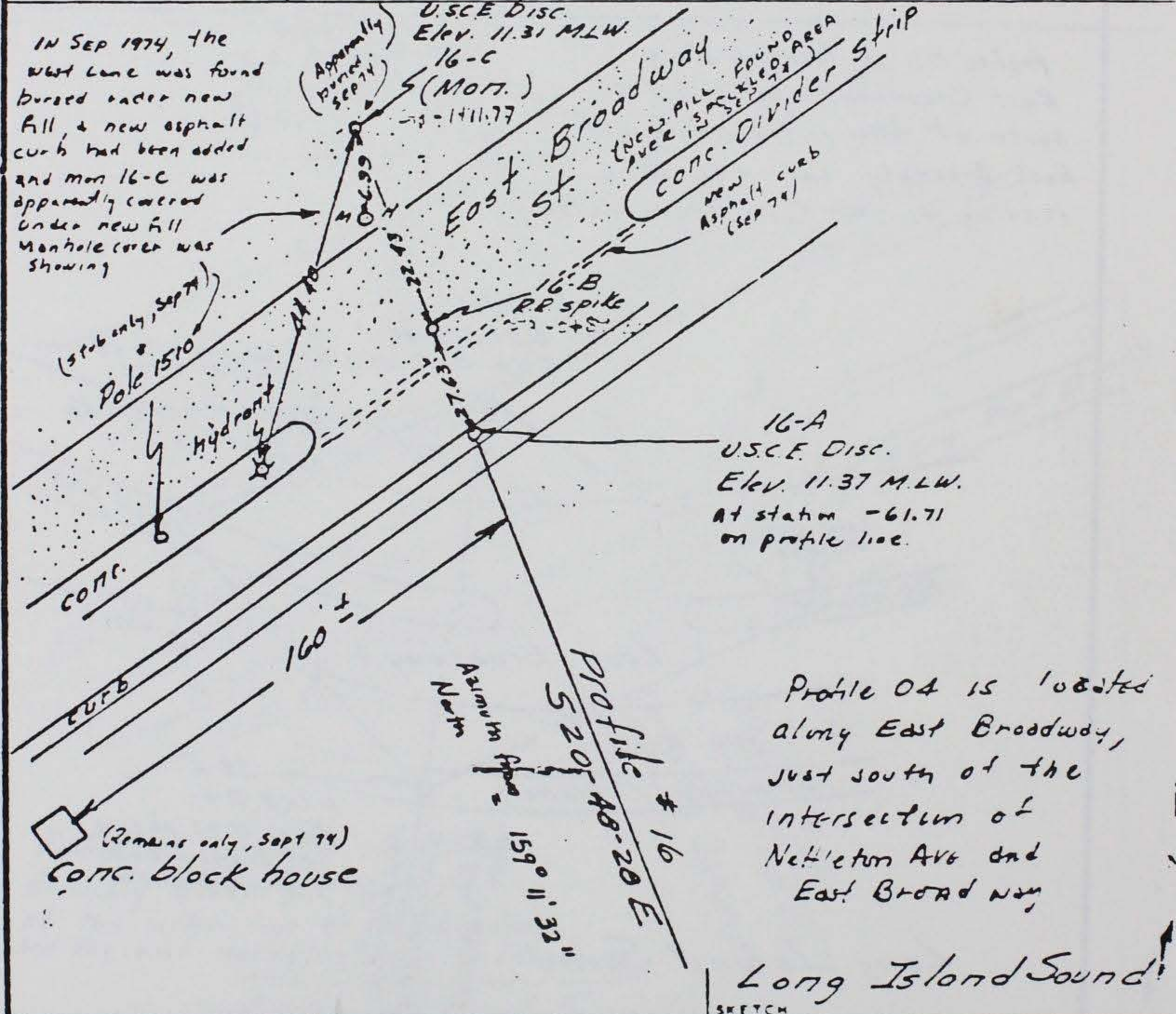

DA FORM 1959 REPLACES DA FORMS 1959 AND 1960, 1 FEB 67, WHICH ARE OBSOLETE. DESCRIPTION OR RECOVERY OF HORIZONTAL CONTROL STA: For use of this form, see TM 5-237; the proponent agency is U.S. Continental Army Command.



COUNTRY U.S.A.	TYPE OF MARK Conc. Mon. with Disc.	STATION Profile No. 2	CERC PROFILE	
LOCALITY Fairfield, Conn.	STAMPING ON MARK Apron .02 (1974)	AGENCY (CAST IN MARKS) C.E.R.C.	ELEVATION Apron 15.24 M.L.W. 02 13.09 M.L.W.	
LATITUDE	LONGITUDE	DATUM North America, 1927	DATUM 1929 SLD	
(NORTHING: <del>112,660.94</del> ) (FT)	(EASTING: <del>465,830.28</del> ) (FT)	GRID AND ZONE Conn. Lambert	ESTABLISHED BY (AGENCY) CERC	
(NORTHING: <del>112,712.83</del> ) (FT)	(EASTING: <del>465,754.06</del> ) (FT)	GRID AND ZONE	DATE 1974	ORDER THIRD

Apron  
02

TO OBTAIN	GRID AZIMUTH, ADD	TO THE GEODETIC AZIMUTH		
TO OBTAIN	GRID AZ. (ADD)(SUB)	TO THE GEODETIC AZIMUTH		
OBJECT	AZIMUTH OR DIRECTION (GEODETIC)(GRID) (MAGNETIC)	BACK AZIMUTH	GEOD. DISTANCE (METERS) (FEET)	GRID DISTANCE (METERS) (FEET)

U.S.C.E. Disc CERC.02 1974  
Elev. 13.09 M.L.W.  
(MOT.) at STA -92.21  
on profile  
line

Profile 01 is located at Jennings  
Public Beach which is at the  
foot of South Benson Road in  
Fairfield, Ct.

chiseled □  
Elev. 15.17 M.L.W.  
See R&H 200 P94

U.S.C.E. Disc "Apron"  
Elev 15.24 M.L.W.  
AT 0+00 ON  
PROFILE LINE

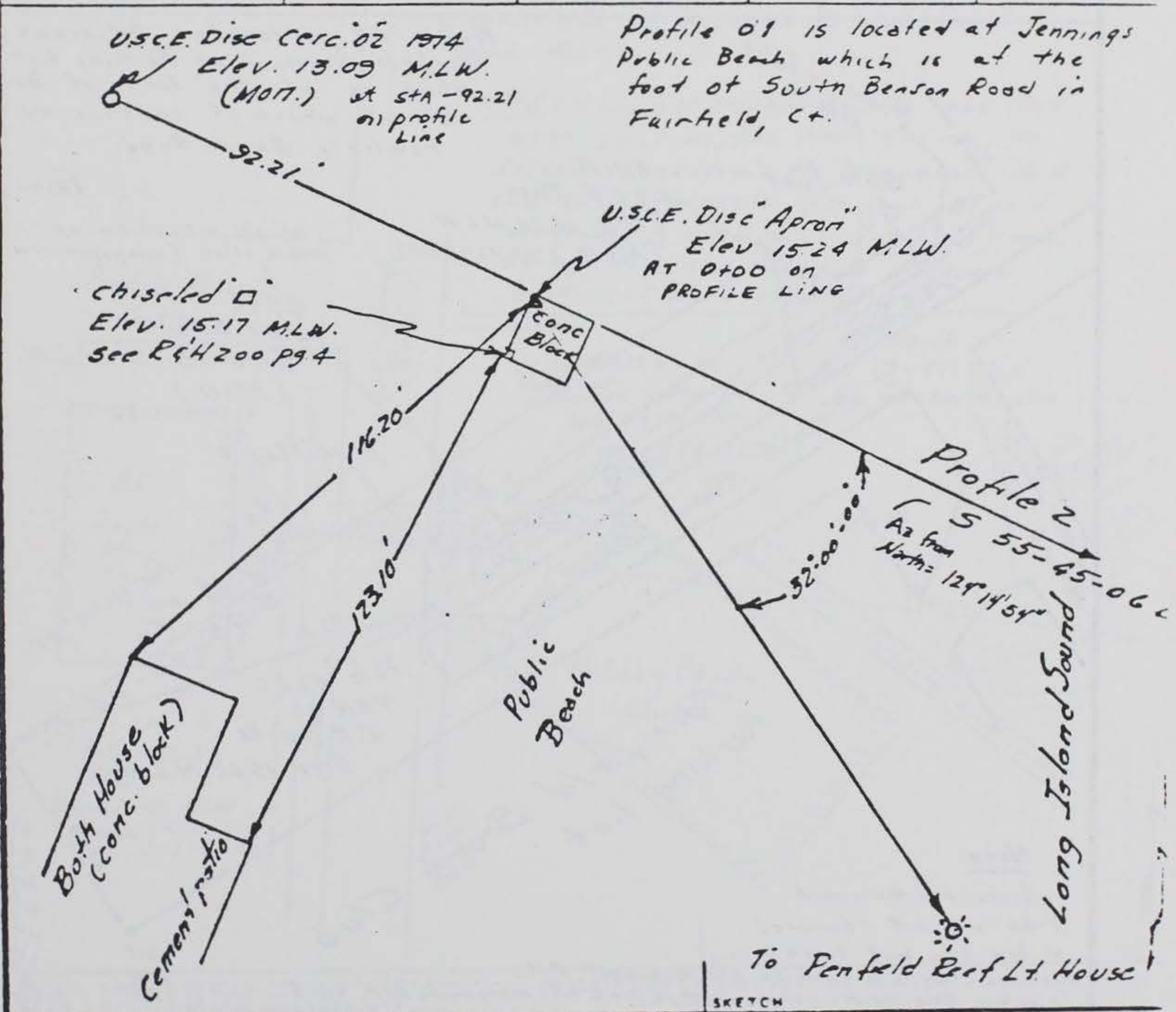

COUNTRY U.S.A.	TYPE OF MARK Conc. Mon. with Disc.	STATION Profile No. 40		CERC PROF. 02
LOCALITY Fairfield, Conn	STAMPING ON MARK 40 A 40 B	AGENCY (CAST IN MARKS) CERC	ELEVATION 40A 13.79 M.L.W. 40B 11.14 M.L.W.	
LATITUDE	LONGITUDE	DATUM North America, 1927	DATUM 1929 SLD	
(NORTHING: <del>111,728.02</del> ) (FT)	(EASTING: <del>465,133.54</del> ) (FT)	GRID AND ZONE Conn. Lambert	ESTABLISHED BY (AGENCY) CERC.	
(NORTHING: <del>111,790.37</del> ) (FT)	(EASTING: <del>464,995.22</del> ) (FT)	GRID AND ZONE	DATE 1974	CHECKED Thiric

40A  
40B

TO OBTAIN	GRID AZIMUTH, ADD	TO THE GEODETIC AZIM		
TO OBTAIN	GRID AZ. (ADD): (SUB.)	TO THE GEODETIC AZIM		
OBJECT	AZIMUTH OR DIRECTION (GEODETIC) (GRID) (MAGNETIC)	BACK AZIMUTH	GEOD DISTANCE (METERS) (FEET)	GRID DISTANCE (METERS) (FEET)

Profile 02 is located adjacent to Fairfield Beach Club Parking Lot which is at the foot of Beach street where it intersects Fairfield Beach Road.

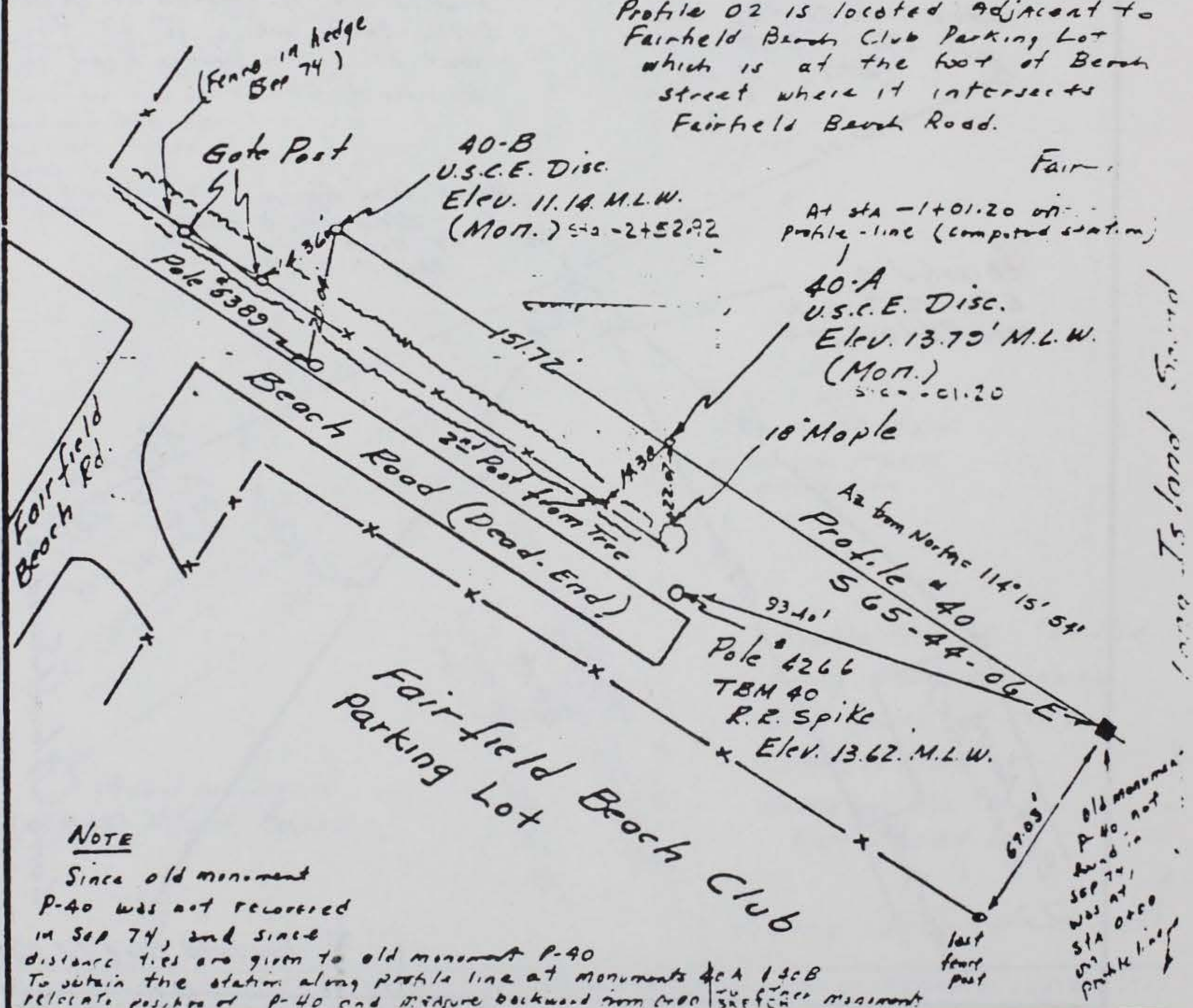

COUNTRY U.S.A.	TYPE OF MARK Conc Mon with Disc	STATION Profile No. 16	CERC Profile 03	
LOCALITY Fairfield, Conn	STAMPING ON MARK 16B 16C	AGENCY (CAST IN MARKS) CERC.	ELEVATION 16B 10.78 (F) 16C 10.10 (F)	
LATITUDE	LONGITUDE	DATUM North America, 1927	DATUM (MLW) 1929 SLD	
(NORTHING: <del>109,459.66</del> ) (FT) 109,459.66 (F)	(EASTING: <del>464,280.95</del> ) (FT) 464,280.95 (F)	GRID AND ZONE Conn Lambert	ESTABLISHED BY (AGENCY) CERC	
(NORTHING: <del>109,469.92</del> ) (FT) 109,469.92 (F)	(EASTING: <del>464,223.99</del> ) (FT) 464,223.99 (F)	GRID AND ZONE Conn Lambert	DATE 1974	ORDER Third
TO OBTAIN	GRID AZIMUTH, ADD	TO THE GEODETIC AZIMUTH		
TO OBTAIN	GRID AZ. (ADD/SUB.)	TO THE GEODETIC AZIMUTH		
OBJECT	AZIMUTH OR DIRECTION (GEODETIC) (GRID) (MAGNETIC)	BACK AZIMUTH	GEOD. DISTANCE (METERS) (FEET)	GRID DISTANCE (METERS) (FEET)

16B  
16C

Profile 03 is located just south of the intersection of Penfield Pl and Fairfield Beach Road.

NOTE: Since old Monument P-16 was the 0+00 point on the profile-line, to determine stations of monuments 16B and 16C, relocate position of old monument (not found in Sep 74) and using ties shown, and measure backward along profile line

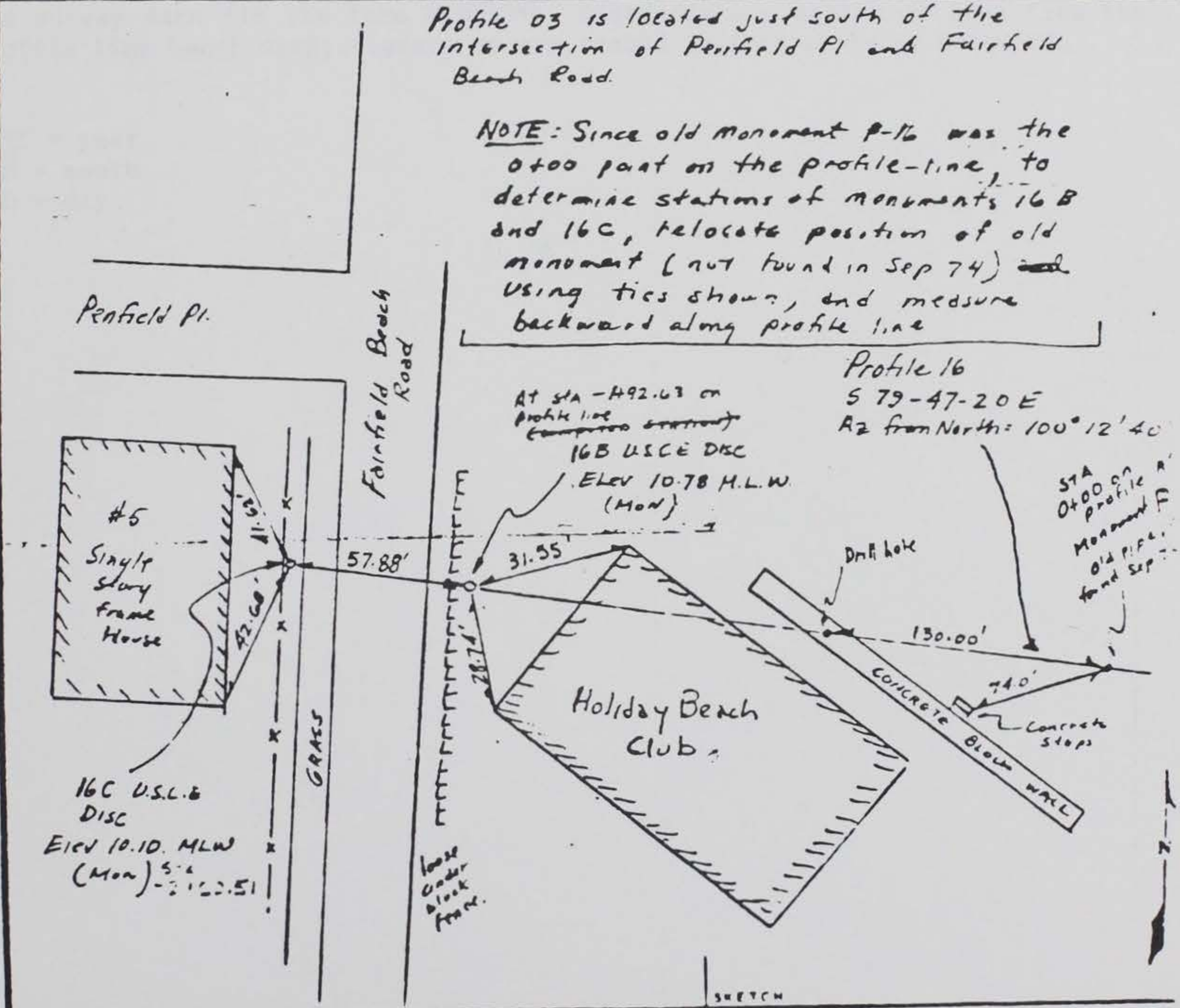

## APPENDIX B

### Profile Line Survey Data for Myrtle Beach

The survey data for Myrtle Beach are tabulated by profile line number and survey date (in the form YYMMDD\*). Distances are stated in feet from the profile line bench mark; elevations are stated in feet above or below MSL.

\*YY = year

MM = month

DD = day

MYRTLE BEACH, CONN.  
DATUM IS MSL MEASUREMENT IS FT

PROFILE 1  
-----

DATE 621100 SRVY 1 TIME 1200	DATE 621213 SRVY 2 TIME 1200	DATE 630102 SRVY 3 TIME 1200	DATE 630117 SRVY 4 TIME 1200	DATE 630130 SRVY 5 TIME 1200	DATE 630215 SRVY 6 TIME 1200	DATE 630301 SRVY 7 TIME 1200	DATE 630311 SRVY 8 TIME 1200								
1.00	11.60	-40.00	11.50	-40.00	11.60	-54.00	12.00	-55.00	12.20	-96.00	12.20	-55.00	12.30	-55.00	12.10
46.00	9.70	0.00	11.50	1.00	11.60	-37.00	11.30	-36.00	11.40	-36.00	11.40	-36.00	11.40	-29.00	11.10
94.00	4.70	29.00	10.50	31.00	10.40	1.00	11.50	3.00	11.60	1.00	11.60	1.00	11.60	0.00	11.70
137.00	3.70	99.00	4.60	69.00	7.40	51.00	9.00	23.00	11.00	92.00	9.00	50.00	9.00	20.00	11.60
155.00	4.60	126.00	3.80	102.00	4.40	90.00	4.80	50.00	9.00	91.00	4.70	92.00	4.70	52.00	9.00
202.00	4.50	199.00	4.60	125.00	3.90	118.00	3.80	97.00	4.60	126.00	3.80	126.00	3.70	92.00	4.70
251.00	3.80	291.00	2.70	201.00	4.50	166.00	4.60	123.00	3.80	196.00	4.70	192.00	4.70	120.00	3.60
301.00	2.90	404.00	1.20	338.00	2.00	212.00	4.30	163.00	4.80	388.00	1.30	389.00	1.30	192.00	4.80
352.00	1.80	492.00	.60	403.00	1.20	372.00	1.40	201.00	4.80	438.00	1.50	436.00	1.50	375.00	1.50
451.00	.80	539.00	1.60	492.00	.70	428.00	1.40	279.00	2.70	490.00	.50	492.00	.60	429.00	1.40
501.00	.90	620.00	-.20	539.00	1.50	488.00	.60	309.00	2.40	554.00	1.30	549.00	1.40	490.00	.70
552.00	1.50			618.00	0.00	532.00	1.40	392.00	1.20	684.00	-1.40	645.00	-.70	534.00	1.50
592.00	.90					632.00	-.30	426.00	1.30					639.00	-.20
628.00	0.00							495.00	.40						
								533.00	1.20						
								629.00	-.30						

PROFILE 1  
-----

DATE 630322 SRVY 9 TIME 1200	DATE 630405 SRVY 10 TIME 1200	DATE 630419 SRVY 11 TIME 1200	DATE 630503 SRVY 12 TIME 1200	DATE 630517 SRVY 13 TIME 1200	DATE 630531 SRVY 14 TIME 1200	DATE 630614 SRVY 15 TIME 1200	DATE 630628 SRVY 16 TIME 1200								
-55.00	12.30	-55.00	12.10	-55.00	12.00	-56.00	12.00	-54.00	12.20	-54.00	12.10	-57.00	12.20		
-36.00	11.40	-39.00	11.20	-31.00	11.30	-30.00	11.20	-35.00	11.20	-26.00	11.30	-30.00	11.20	-32.00	11.30
1.00	11.60	0.00	11.40	1.00	11.40	0.00	11.50	0.00	11.40	0.00	11.50	1.00	11.40	0.00	11.30
50.00	9.00	36.00	10.30	20.00	10.80	26.00	11.50	55.00	8.80	34.00	9.80	61.00	8.00	60.00	8.70
95.00	4.50	71.00	7.30	66.00	7.40	56.00	8.40	92.00	4.90	60.00	8.10	91.00	4.50	91.00	4.70
123.00	4.00	96.00	4.50	95.00	4.80	66.00	8.00	129.00	3.80	90.00	4.70	120.00	3.60	131.00	3.70
157.00	4.90	121.00	3.80	124.00	3.90	96.00	4.40	162.00	4.80	122.00	3.80	160.00	4.70	157.00	4.70
383.00	1.30	184.00	4.70	171.00	4.90	127.00	3.60	390.00	1.20	161.00	4.80	312.00	2.30	313.00	2.70
425.00	1.50	393.00	1.10	387.00	1.20	168.00	4.70	420.00	1.40	239.00	3.70	382.00	1.00	382.00	1.10
494.00	.50	426.00	1.50	435.00	1.50	387.00	1.00	484.00	.70	382.00	1.10	425.00	1.20	428.00	1.40
535.00	1.50	493.00	.40	489.00	.50	423.00	1.30	528.00	1.50	419.00	1.40	484.00	.30	483.00	.50
643.00	-.80	535.00	1.40	538.00	1.30	488.00	.30	628.00	-.20	482.00	.50	523.00	1.20	523.00	1.30
		659.00	-.90	625.00	-.10	529.00	1.20			537.00	1.40	622.00	-.30	624.00	0.00
						620.00	-.60			623.00	-.30				

B-1

MYRTLE BEACH, CONN.  
DATUM IS MSL MEASUREMENT IS FT

PROFILE 1

DATE 630717 SRVY 17 TIME 1200	DATE 630820 SRVY 18 TIME 1200	DATE 630925 SRVY 19 TIME 1200	DATE 631022 SRVY 20 TIME 1200	DATE 631127 SRVY 21 TIME 1200	DATE 631204 SRVY 22 TIME 1200	DATE 631223 SRVY 23 TIME 1200	DATE 640123 SRVY 24 TIME 1200								
54.00	12.10	53.00	12.00	53.00	12.10	50.00	12.00	54.00	12.20	55.00	12.20	53.00	12.00	54.00	12.10
3.00	11.50	0.00	11.40	0.00	11.40	0.00	11.30	10.00	11.00	1.00	11.40	1.00	11.50	0.00	11.60
58.00	8.60	61.00	8.40	54.00	9.10	54.00	9.20	48.00	9.20	21.00	11.00	28.00	10.50	39.00	10.50
102.00	4.40	101.00	4.30	100.00	4.00	95.00	4.40	93.00	4.30	51.00	9.10	51.00	9.00	92.00	4.40
127.00	3.80	128.00	3.80	125.00	4.00	151.00	4.30	101.00	3.90	93.00	4.30	100.00	3.90	101.00	3.80
152.00	4.90	152.00	4.60	152.00	4.40	201.00	3.80	200.00	4.10	100.00	3.90	150.00	3.90	151.00	3.30
301.00	2.90	292.00	3.50	202.00	3.80	253.00	3.90	251.00	3.80	200.00	4.40	201.00	4.30	201.00	3.30
354.00	1.90	352.00	1.60	255.00	3.70	352.00	1.50	352.00	1.60	351.00	1.60	252.00	3.40	254.00	3.50
457.00	.90	403.00	1.50	354.00	1.40	404.00	1.50	402.00	1.50	401.00	1.50	351.00	1.40	352.00	1.80
503.00	1.50	445.00	1.00	404.00	1.40	454.00	.90	452.00	.80	452.00	.80	404.00	1.30	451.00	1.00
557.00	1.40	507.00	1.50	452.00	.60	505.00	1.30	503.00	1.60	502.00	1.60	452.00	.70	504.00	1.60
617.00	.10	554.00	1.00	504.00	1.40	555.00	1.20	554.00	1.00	553.00	1.00	503.00	1.60	553.00	1.00
653.00	1.00	653.00	1.00	619.00	0.00	653.00	1.70	604.00	0.00	604.00	0.00	554.00	.70	653.00	1.00
								653.00	1.70	655.00	0.00	652.00	1.90		
										703.00	1.00	702.00	0.00		

PROFILE 1

DATE 640228 SRVY 25 TIME 1200	DATE 640420 SRVY 26 TIME 1200	DATE 640519 SRVY 27 TIME 1200	DATE 640618 SRVY 28 TIME 1200	DATE 640721 SRVY 29 TIME 1200	DATE 640916 SRVY 30 TIME 1200	DATE 640930 SRVY 31 TIME 1200	DATE 641202 SRVY 32 TIME 1200								
55.00	12.10	54.00	12.10	55.00	12.10	54.00	12.10	0.00	11.20	55.00	12.00	50.00	12.10	51.00	12.10
0.00	11.60	0.00	11.60	0.00	11.40	0.00	11.50	45.00	9.20	0.00	11.50	1.00	11.50	1.00	11.60
41.00	10.20	26.00	10.50	35.00	9.80	42.00	9.80	93.00	4.40	42.00	9.70	43.00	9.80	35.00	10.00
90.00	4.70	52.00	8.90	52.00	8.40	90.00	4.90	100.00	4.10	50.00	9.10	92.00	4.60	76.00	7.00
100.00	4.30	61.00	8.10	92.00	4.50	99.00	4.30	153.00	4.80	92.00	4.10	102.00	4.10	91.00	5.40
161.00	4.80	93.00	4.40	99.00	4.20	151.00	4.80	252.00	3.00	153.00	4.80	152.00	4.90	101.00	5.10
204.00	4.30	101.00	4.10	153.00	4.70	202.00	4.10	305.00	2.50	252.00	2.90	203.00	3.70	153.00	4.90
294.00	2.40	152.00	4.40	209.00	3.80	254.00	3.10	352.00	1.80	304.00	2.50	255.00	2.90	201.00	3.50
352.00	1.50	201.00	4.30	253.00	3.00	352.00	1.80	403.00	.80	404.00	.90	303.00	2.80	252.00	2.60
415.00	1.10	252.00	3.20	354.00	1.70	405.00	1.00	453.00	1.50	455.00	1.50	403.00	1.10	302.00	2.80
452.00	1.00	352.00	1.90	404.00	1.00	456.00	1.50	504.00	1.40	505.00	1.50	505.00	1.70	403.00	1.00
503.00	1.60	406.00	1.20	455.00	1.50	505.00	.90	554.00	.90	557.00	.80	604.00	0.00	434.00	.80
604.00	1.00	504.00	1.60	505.00	1.40	555.00	1.00	605.00	0.00	604.00	1.10	654.00	0.00	453.00	1.30
704.00	1.00	553.00	1.00	556.00	.90	606.00	0.00	705.00	1.30	655.00	1.10			505.00	2.00
		603.00	1.00	604.00	0.00	698.00	0.00							604.00	.10
		653.00	1.00	698.00	0.00									655.00	0.00
		704.00	1.10											704.00	1.40

MYRTLE BEACH, CONN.  
DATUM IS MSL MEASUREMENT IS FT

PROFILE 1  
-----

DATE 650211 SRVY 33 TIME 1200	DATE 650409 SRVY 34 TIME 1200	DATE 650607 SRVY 35 TIME 1200	DATE 650914 SRVY 36 TIME 1200	DATE 651220 SRVY 37 TIME 1200	DATE 660124 SRVY 38 TIME 1200	DATE 660505 SRVY 39 TIME 1200	DATE 660826 SRVY 41 TIME 1200								
-52.00	12.30	-51.00	12.00	-1.00	11.40	-51.00	12.10	-52.00	12.20	-52.00	12.20	-51.00	12.20	-51.00	12.10
0.00	11.60	-1.00	11.40	39.00	9.80	0.00	11.40	1.00	11.40	0.00	10.90	1.00	10.70	50.00	8.70
51.00	9.30	102.00	6.00	64.00	8.10	51.00	8.90	51.00	9.20	50.00	8.60	52.00	8.80	70.00	8.40
95.00	5.70	202.00	3.00	78.00	8.30	101.00	4.80	90.00	5.40	100.00	5.40	74.00	8.30	104.00	4.40
102.00	5.70	252.00	3.60	100.00	5.90	151.00	3.50	152.00	3.60	152.00	3.60	111.00	4.30	151.00	3.50
230.00	3.00	353.00	1.60	201.00	2.80	204.00	2.70	195.00	2.90	202.00	3.80	125.00	3.50	202.00	3.90
253.00	3.20	403.00	.90	254.00	3.50	228.00	3.50	203.00	3.40	252.00	3.20	203.00	3.70	252.00	3.00
304.00	3.00	428.00	2.00	303.00	2.60	253.00	3.40	254.00	3.40	303.00	2.10	253.00	3.00	302.00	1.70
404.00	1.10	456.00	2.10	402.00	.90	354.00	1.30	303.00	2.40	353.00	1.40	310.00	2.00	352.00	1.20
424.00	1.00	555.00	.50	428.00	2.10	397.00	1.00	353.00	1.50	383.00	1.40	353.00	1.40	403.00	2.30
454.00	2.00	605.00	0.00	454.00	2.10	418.00	1.80	397.00	1.20	403.00	2.30	403.00	2.00	503.00	.50
505.00	1.80	705.00	-.20	505.00	1.30	454.00	1.70	403.00	1.90	454.00	1.90	455.00	1.90	604.00	.30
605.00	.10			555.00	.50	505.00	1.20	435.00	2.30	504.00	.90	503.00	.90	654.00	-.50
646.00	.60			656.00	-.10	554.00	.20	462.00	1.80	555.00	.30	555.00	.20	704.00	-.80
705.00	-.40			705.00	-.50	598.00	.50	506.00	.70	605.00	.20	606.00	.50		
						607.00	.40	604.00	.40	655.00	-.40	656.00	-.40		
						655.00	-.40	655.00	-.20			695.00	-.90		

PROFILE 1  
-----

DATE 661108 SRVY 42 TIME 1200	DATE 670206 SRVY 43 TIME 1200	DATE 670503 SRVY 44 TIME 1200	DATE 670602 SRVY 45 TIME 1200	DATE 670912 SRVY 46 TIME 1200	DATE 671226 SRVY 47 TIME 1200	DATE 680306 SRVY 48 TIME 1200	DATE 681125 SRVY 49 TIME 1200								
-51.00	12.10	-53.00	12.10	-1.00	10.90	-1.00	11.00	-52.00	11.90	-51.00	12.10	-50.00	11.90	-53.00	12.10
55.00	9.80	0.00	10.90	50.00	9.80	50.00	10.40	5.00	10.60	0.00	10.90	0.00	10.80	0.00	10.40
63.00	8.50	41.00	10.50	101.00	4.80	101.00	4.70	50.00	9.10	50.00	9.60	26.00	9.50	50.00	8.60
103.00	4.40	101.00	5.00	152.00	4.40	151.00	4.60	73.00	7.80	96.00	6.90	70.00	8.90	73.00	8.60
151.00	3.40	151.00	4.60	253.00	2.40	253.00	2.40	86.00	8.10	101.00	6.90	101.00	6.00	90.00	7.50
202.00	3.80	202.00	3.60	304.00	1.70	304.00	1.70	101.00	6.00	118.00	4.60	112.00	4.60	100.00	7.70
253.00	2.30	252.00	2.20	354.00	2.50	354.00	2.50	112.00	4.90	151.00	4.30	151.00	4.30	138.00	4.40
327.00	1.60	303.00	1.70	454.00	1.00	405.00	1.90	152.00	4.70	202.00	3.50	201.00	3.10	150.00	4.70
345.00	2.60	353.00	2.30	505.00	.80	454.00	1.20	303.00	1.80	253.00	2.30	252.00	1.80	175.00	2.70
402.00	2.30	404.00	1.90	556.00	.80	505.00	1.00	329.00	2.50	354.00	2.20	302.00	2.20	200.00	2.30
453.00	1.10	454.00	.90	656.00	-.90	555.00	.90	355.00	2.50	404.00	1.50	352.00	1.70	246.00	1.60
504.00	.40	504.00	1.00			656.00	-.80	410.00	1.80	454.00	1.20	402.00	1.20	250.00	1.60
538.00	1.00	556.00	.70					457.00	1.00	505.00	.50	453.00	.90	300.00	2.30
555.00	.90	655.00	-.70					555.00	.70	554.00	.80	503.00	.30	350.00	2.30
605.00	0.00							605.00	.20	605.00	.20	553.00	.70	381.00	2.00
704.00	-.60							655.00	-.70	657.00	.70	604.00	0.00	400.00	1.70
										706.00	-1.00	654.00	-.70	450.00	1.10
														500.00	.60
														550.00	.60
														600.00	-.10

B-3

MYRTLE BEACH, CONN.  
DATUM IS MSL MEASUREMENT IS FT

PROFILE 1  
-----

DATE 690311	DATE 690610	DATE 690923	DATE 691230	DATE 700616	DATE 710419
SRVY 50	SRVY 51	SRVY 52	SRVY 53	SRVY 54	SRVY 55
TIME 1200	TIME 1200	TIME 1200	TIME 1200	TIME 1200	TIME 1200
0.00	10.50	53.00	11.90	53.00	12.10
50.00	9.00	0.00	10.30	0.00	10.70
82.00	9.10	50.00	8.70	23.00	10.30
100.00	7.20	89.00	8.40	56.00	9.00
122.00	4.60	100.00	7.50	100.00	6.70
150.00	3.30	138.00	3.50	108.00	6.30
200.00	2.90	150.00	3.10	121.00	4.50
250.00	1.60	186.00	2.80	150.00	3.50
300.00	2.30	200.00	1.50	175.00	2.90
350.00	2.00	250.00	2.00	200.00	2.50
400.00	1.50	300.00	1.90	250.00	1.80
450.00	1.20	350.00	1.70	275.00	1.90
500.00	.90	400.00	1.30	300.00	2.00
550.00	.90	450.00	1.00	350.00	2.00
600.00	.30	500.00	.90	400.00	1.70
650.00	.60	550.00	.40	450.00	1.30
700.00	-1.10	600.00	.90	500.00	1.00
		650.00	.20	550.00	.80
		700.00	-1.00	600.00	.50
				650.00	-.50
				700.00	-.20
					475.00
					500.00
					525.00
					550.00
					575.00
					600.00
					625.00

PROFILE 2  
-----

DATE 621109	DATE 621213	DATE 630102	DATE 630117	DATE 630130	DATE 630215	DATE 630301	DATE 630311
SRVY 1	SRVY 2	SRVY 3	SRVY 4	SRVY 5	SRVY 6	SRVY 7	SRVY 8
TIME 1200	TIME 1200	TIME 1200	TIME 1200	TIME 1200	TIME 1200	TIME 1200	TIME 1200
33.00	12.20	34.00	11.20	32.00	11.30	33.00	11.50
55.00	11.40	60.00	11.20	60.00	11.30	61.00	11.30
101.00	8.10	107.00	7.60	111.00	7.20	85.00	8.40
162.00	1.70	161.00	1.90	161.00	1.90	96.00	8.30
251.00	.70	300.00	.50	292.00	.50	151.00	2.10
302.00	.70	408.00	-.30	382.00	.10	219.00	1.00
352.00	.20			407.00	-.30	343.00	.70
388.00	0.00					416.00	-.40
						350.00	.50
						423.00	-.60
						464.00	-.20
						417.00	-.40
						429.00	-.30
							251.00
							156.00
							303.00
							353.00
							418.00

B-4



MYRTLE BEACH, CONN.  
DATUM IS MSL MEASUREMENT IS FT

PROFILE 2  
-----

DATE 630322	DATE 630405	DATE 630419	DATE 630503	DATE 630517	DATE 630531	DATE 630614	DATE 630628
SRVY 9	SRVY 10	SRVY 11	SRVY 12	SRVY 13	SRVY 14	SRVY 15	SRVY 16
TIME 1200	TIME 1200	TIME 1200	TIME 1200	TIME 1200	TIME 1200	TIME 1200	TIME 1200
-----	-----	-----	-----	-----	-----	-----	-----
50.00 11.10	34.00 11.60	33.00 11.50	32.00 11.50	40.00 11.20	32.00 11.80	41.00 10.90	30.00 12.00
61.00 11.20	42.00 10.90	40.00 10.80	44.00 11.10	57.00 11.30	41.00 10.90	61.00 11.10	40.00 10.90
94.00 8.00	61.00 11.20	60.00 11.20	56.00 11.40	111.00 6.70	61.00 11.10	93.00 8.30	52.00 11.30
100.00 8.10	156.00 1.80	92.00 8.20	86.00 8.70	149.00 1.90	100.00 7.50	136.00 3.00	63.00 10.90
151.00 1.80	304.00 .50	109.00 7.20	94.00 8.50	378.00 .40	146.00 1.80	152.00 1.70	92.00 8.60
263.00 .60	369.00 .60	152.00 1.80	156.00 2.00	417.00 -.10	396.00 -.30	228.00 .80	97.00 8.60
331.00 .40	427.00 -.50	221.00 1.10	221.00 1.00			368.00 .30	151.00 2.00
407.00 0.00		389.00 0.00	407.00 -.20			404.00 -.50	224.00 .90
		416.00 -.40					329.00 .50
							433.00 -.80

PROFILE 2  
-----

DATE 630717	DATE 630820	DATE 630925	DATE 631022	DATE 631127	DATE 631204	DATE 631223	DATE 640123
SRVY 17	SRVY 18	SRVY 19	SRVY 20	SRVY 21	SRVY 22	SRVY 23	SRVY 24
TIME 1200	TIME 1200	TIME 1200	TIME 1200	TIME 1200	TIME 1200	TIME 1200	TIME 1200
-----	-----	-----	-----	-----	-----	-----	-----
34.00 11.50	33.00 11.60	34.00 11.50	33.00 11.50	33.00 11.40	33.00 11.40	33.00 11.30	33.00 11.30
56.00 10.90	51.00 11.10	51.00 11.00	50.00 11.10	51.00 11.10	54.00 11.40	50.00 11.30	54.00 11.20
96.00 8.70	95.00 8.80	70.00 10.10	101.00 7.00	77.00 9.60	70.00 8.90	67.00 9.00	66.00 9.60
151.00 1.90	151.00 1.90	136.00 2.20	137.00 2.60	142.00 1.60	83.00 7.30	93.00 7.20	82.00 8.50
261.00 .70	201.00 1.20	153.00 1.70	152.00 1.70	152.00 1.80	102.00 6.00	151.00 1.90	131.00 2.90
354.00 .30	302.00 .50	252.00 .70	252.00 .80	352.00 .40	150.00 1.40	201.00 .90	151.00 2.10
394.00 0.00	353.00 .30	353.00 0.00	302.00 .60	401.00 -.30	202.00 .10	251.00 .70	201.00 1.30
418.00 -.30	402.00 -.50	402.00 -.50	352.00 .40	456.00 -.50	301.00 .50	351.00 .20	252.00 .80
			402.00 0.00	501.00 0.00	352.00 .30	401.00 -.70	302.00 .90
				551.00 -1.00	407.00 -.60	451.00 -.60	351.00 .40
					503.00 0.00		402.00 -.10
					551.00 -1.00		

B-5

MYRTLE BEACH, CONN.  
DATUM IS MSL MEASUREMENT IS FT

PROFILE 2  
-----

DATE 640224 SRVY 25 TIME 1200	DATE 640420 SRVY 26 TIME 1200	DATE 640519 SRVY 27 TIME 1200	DATE 640618 SRVY 28 TIME 1200	DATE 640721 SRVY 29 TIME 1200	DATE 640916 SRVY 30 TIME 1200	DATE 640930 SRVY 31 TIME 1200	DATE 641202 SRVY 32 TIME 1200								
32.00	11.90	32.00	11.40	31.00	11.80	32.00	11.70	33.00	11.50	32.00	11.60	33.00	11.90	33.00	11.90
51.00	11.30	49.00	11.40	50.00	11.50	50.00	11.10	50.00	11.10	54.00	11.10	52.00	10.40	51.00	11.20
136.00	2.90	85.00	8.10	48.00	8.10	88.00	8.30	151.00	1.70	104.00	6.10	73.00	9.20	75.00	8.00
202.00	1.00	132.00	2.40	137.00	1.80	137.00	1.80	207.00	.90	131.00	1.80	81.00	7.80	104.00	5.70
252.00	.90	202.00	1.20	151.00	1.80	151.00	1.80	252.00	.80	152.00	1.40	102.00	5.70	134.00	1.60
302.00	1.10	251.00	.80	202.00	1.00	202.00	1.00	303.00	.90	202.00	1.20	130.00	2.00	152.00	1.30
352.00	.40	302.00	1.00	252.00	.80	252.00	.80	358.00	.40	222.00	1.00	151.00	1.30	202.00	1.30
403.00	-.90	352.00	.50	372.00	1.10	302.00	1.10	403.00	-.60	252.00	.70	203.00	1.20	252.00	.60
502.00	0.00	402.00	-.20	353.00	.50	352.00	.50			302.00	1.10	251.00	.80	302.00	1.10
553.00	-1.00	502.00	.20	403.00	-.50	403.00	-.50			353.00	.50	301.00	1.10	402.00	-.10
		552.00	-1.00	555.00	.20	454.00	-.10			402.00	-.30	402.00	-.20		
				503.00	-.50	504.00	-.20								
				556.00	-.70	554.00	-1.00								

PROFILE 2  
-----

DATE 650211 SRVY 33 TIME 1200	DATE 650405 SRVY 34 TIME 1200	DATE 650607 SRVY 35 TIME 1200	DATE 650914 SRVY 36 TIME 1200	DATE 651220 SRVY 37 TIME 1200	DATE 660124 SRVY 38 TIME 1200	DATE 660505 SRVY 39 TIME 1200	DATE 660826 SRVY 41 TIME 1200								
33.00	12.00	33.00	12.00	33.00	11.90	32.00	11.90	34.00	9.40	33.00	9.60	33.00	9.50	33.00	8.50
51.00	10.70	50.00	11.00	51.00	10.60	50.00	10.50	102.00	1.40	101.00	3.50	61.00	8.00	58.00	8.50
77.00	7.80	62.00	9.00	66.00	8.50	55.00	9.00	152.00	1.90	111.00	2.80	121.00	2.30	101.00	2.80
103.00	5.10	101.00	9.20	77.00	8.20	101.00	3.60	239.00	.30	205.00	.90	202.00	.40	202.00	.40
134.00	1.80	129.00	1.80	127.00	1.80	137.00	1.40	303.00	1.50	253.00	.50	252.00	.30	302.00	1.30
153.00	1.40	152.00	1.80	203.00	1.30	151.00	1.90	354.00	.60	303.00	1.00	303.00	1.20	353.00	.70
203.00	1.30	202.00	1.20	251.00	.40	237.00	.30	452.00	.80	354.00	.70	353.00	.80	403.00	-.80
253.00	.40	252.00	.50	305.00	.90	281.00	.80			403.00	0.00	403.00	-.50		
303.00	.90	302.00	.90	354.00	.50	352.00	.50								
356.00	.40	353.00	.80	453.00	-.70	453.00	-.60								
405.00	0.00	453.00	-.70												
454.00	-.50														

B-6

MYRTLE BEACH, CONN.  
DATUM IS MSL MEASUREMENT IS FT

PROFILE 2  
-----

DATE 661108 SRVY 42 TIME 1200	DATE 670206 SRVY 43 TIME 1200	DATE 670503 SRVY 44 TIME 1200	DATE 670602 SRVY 45 TIME 1200	DATE 670912 SRVY 46 TIME 1200	DATE 671226 SRVY 47 TIME 1200	DATE 680306 SRVY 48 TIME 1200	DATE 681125 SRVY 49 TIME 1200								
34.00	10.90	34.00	10.70	33.00	11.10	33.00	11.20	36.00	10.60	35.00	10.70	35.00	10.30	33.00	10.00
52.00	8.90	51.00	8.70	51.00	9.00	50.00	10.40	50.00	10.00	50.00	10.50	41.00	9.40	50.00	8.40
122.00	2.10	65.00	7.90	62.00	9.30	67.00	8.90	66.00	8.80	67.00	8.90	69.00	9.30	68.00	8.20
203.00	.70	112.00	2.30	119.00	1.80	120.00	2.10	87.00	7.50	87.00	7.70	86.00	7.30	100.00	4.60
266.00	1.00	152.00	1.80	151.00	1.60	152.00	1.90	102.00	3.90	101.00	4.00	81.00	6.40	121.00	2.20
303.00	1.40	202.00	.40	202.00	.40	202.00	.60	119.00	1.80	121.00	1.90	117.00	2.00	150.00	1.60
353.00	.70	253.00	.60	253.00	.20	253.00	.40	152.00	1.50	152.00	1.60	150.00	1.50	200.00	.40
403.00	-.60	282.00	1.40	303.00	1.10	303.00	1.10	202.00	.30	202.00	.60	201.00	.40	231.00	-.20
453.00	-.80	303.00	1.50	354.00	.40	353.00	.60	253.00	.20	254.00	.50	251.00	.20	250.00	.30
		353.00	.70	403.00	-1.00	403.00	-.90	304.00	.90	302.00	.90	302.00	.40	300.00	1.30
		403.00	-1.10					354.00	.30	354.00	.40	351.00	.70	350.00	.50
								403.00	-.60	404.00	-.40	397.00	-.90	400.00	-1.10
								428.00	-1.20	454.00	-1.60				

PROFILE 2  
-----

DATE 690311 SRVY 50 TIME 1200	DATE 690610 SRVY 51 TIME 1200	DATE 690923 SRVY 52 TIME 1200	DATE 691230 SRVY 53 TIME 1200	DATE 700616 SRVY 54 TIME 1200	DATE 710419 SRVY 55 TIME 1200						
31.00	12.30	33.00	9.70	33.00	9.00	33.00	8.00	33.00	9.10	33.00	12.30
33.00	9.90	50.00	7.50	50.00	6.90	57.00	6.30	45.00	8.20	34.00	8.10
56.00	9.20	100.00	2.00	87.00	2.10	82.00	3.60	50.00	7.40	50.00	5.90
80.00	6.40	150.00	-.70	100.00	1.90	100.00	2.60	93.00	2.10	75.00	2.60
100.00	3.40	200.00	-.30	150.00	1.10	150.00	1.40	100.00	1.80	100.00	2.20
114.00	1.80	250.00	.10	200.00	.90	200.00	.90	150.00	1.40	125.00	2.00
150.00	1.40	300.00	.80	250.00	0.00	228.00	.10	190.00	1.40	150.00	1.60
200.00	.40	350.00	.90	300.00	.60			200.00	1.50	175.00	1.10
250.00	.30	400.00	-.90	350.00	.80			250.00	0.00	200.00	.70
300.00	1.40			400.00	-.70			300.00	.20	225.00	.20
350.00	.50							343.00	.70	250.00	.20
400.00	-1.20							356.00	.50	275.00	.70
450.00	-1.40							400.00	-1.00	300.00	.70
475.00	0.00									325.00	.50
500.00	.20									350.00	.50
550.00	-1.30									375.00	0.00
										400.00	-.60

B-7

MYRTLE BEACH, CONN.  
DATUM IS MSL MEASUREMENT IS FT

PROFILE 3  
-----

DATE 651220 SRVY 37 TIME 1200	DATE 660124 SRVY 38 TIME 1200	DATE 660505 SRVY 39 TIME 1200	DATE 660823 SRVY 41 TIME 1200	DATE 661108 SRVY 42 TIME 1200	DATE 670206 SRVY 43 TIME 1200	DATE 670503 SRVY 44 TIME 1200	DATE 670602 SRVY 45 TIME 1200								
80.00	5.20	80.00	5.90	81.00	5.90	80.00	7.80	79.00	7.70	79.00	8.20	79.00	8.10	79.00	8.10
101.00	4.00	101.00	3.90	101.00	3.90	83.00	5.50	81.00	4.90	82.00	5.30	81.00	5.40	81.00	5.30
137.00	3.30	137.00	3.40	137.00	3.30	103.00	4.00	102.00	3.90	151.00	2.40	101.00	3.90	101.00	3.90
151.00	2.50	202.00	1.30	202.00	1.30	153.00	2.70	136.00	3.30	252.00	.30	150.00	3.40	150.00	3.50
185.00	1.50	304.00	.60	253.00	.80	182.00	1.40	151.00	2.20	304.00	.40	187.00	1.00	188.00	1.00
201.00	1.50	353.00	.30	354.00	.40	254.00	.40	181.00	1.00	354.00	.40	203.00	1.00	204.00	1.10
252.00	.80	404.00	0.00	405.00	.10	311.00	.30	203.00	1.00	411.00	0.00	253.00	.40	253.00	.30
302.00	.60	453.00	-.10	453.00	-.30	355.00	0.00	253.00	.30	453.00	-.10	404.00	.50	403.00	.30
353.00	.40					424.00	0.00	305.00	.30	505.00	-.40	455.00	-.50	455.00	-.40
404.00	0.00					503.00	-.60	407.00	.10	554.00	-1.20	504.00	-.50	505.00	-.50
453.00	0.00							455.00	-.50			555.00	-1.20	555.00	-1.20
								504.00	-.50						

PROFILE 3  
-----

DATE 670912 SRVY 46 TIME 1200	DATE 671226 SRVY 47 TIME 1200	DATE 680306 SRVY 48 TIME 1200	DATE 681125 SRVY 49 TIME 1200	DATE 690311 SRVY 50 TIME 1200	DATE 690610 SRVY 51 TIME 1200	DATE 690923 SRVY 52 TIME 1200	DATE 691230 SRVY 53 TIME 1200								
79.00	8.00	80.00	8.00	79.00	7.30	80.00	5.40	96.00	3.90	78.00	7.20	80.00	5.20	80.00	5.30
81.00	5.00	82.00	5.10	81.00	5.10	100.00	3.90	125.00	3.40	80.00	5.20	100.00	3.80	100.00	3.80
100.00	3.80	101.00	4.00	100.00	3.80	126.00	3.40	150.00	1.80	100.00	3.80	125.00	3.30	125.00	3.30
152.00	2.20	143.00	2.80	138.00	3.30	150.00	2.10	200.00	.60	125.00	3.20	150.00	1.60	150.00	1.80
173.00	1.30	193.00	2.20	151.00	1.90	192.00	.80	250.00	.10	190.00	1.70	200.00	.70	200.00	.60
202.00	1.00	174.00	1.30	201.00	.80	200.00	.70	300.00	.70	166.00	1.00	250.00	.10	250.00	-.20
252.00	.30	254.00	.50	251.00	.10	250.00	0.00	350.00	.80	200.00	.40	300.00	.70		
304.00	.30	303.00	.50	302.00	.20	300.00	.50	400.00	-.40	250.00	0.00	350.00	.90		
403.00	-.10	354.00	.10	352.00	0.00	350.00	.40	450.00	-.10	300.00	.70	400.00	-.40		
455.00	-.50	405.00	-.10	402.00	.30	400.00	-.20	475.00	.50	350.00	.70				
472.00	-.90	456.00	-.70	452.00	-1.10	450.00	-.70	500.00	0.00	400.00	-.50				
505.00	-1.10	505.00	-1.10												

B-8

MYRTLE BEACH, CONN.  
DATUM IS MSL MEASUREMENT IS FT

PROFILE 3  
-----

DATE	700616
SRVY	54
TIME	1200
-----	-----
80.00	5.10
90.00	4.10
100.00	3.80
122.00	3.10
150.00	1.40
200.00	.70
250.00	0.00
300.00	.80
336.00	.90
350.00	.60
400.00	-.50

PROFILE 4  
-----

DATE	621109	DATE	621213	DATE	630102	DATE	630117	DATE	630130	DATE	630215	DATE	630301	DATE	630311
SRVY	1	SRVY	2	SRVY	3	SRVY	4	SRVY	5	SRVY	6	SRVY	7	SRVY	8
TIME	1200	TIME	1200	TIME	1200	TIME	1200	TIME	1200	TIME	1200	TIME	1200	TIME	1200
-----	-----	-----	-----	-----	-----	-----	-----	-----	-----	-----	-----	-----	-----	-----	-----
1.00	10.00	-60.00	11.30	-62.00	11.30	-60.00	11.40	-61.00	11.50	-62.00	11.50	-61.00	11.40	-60.00	11.40
61.00	10.70	-33.00	11.30	-33.00	11.30	-38.00	11.50	-42.00	11.60	-40.00	11.60	-41.00	11.80	-40.00	11.60
91.00	8.90	0.00	10.20	0.00	10.10	0.00	10.00	0.00	10.00	1.00	10.00	1.00	10.00	0.00	9.90
161.00	8.50	48.00	10.90	50.00	10.90	58.00	10.80	57.00	10.80	62.00	10.90	55.00	11.00	55.00	10.90
200.00	7.30	87.00	10.20	85.00	10.30	83.00	10.10	101.00	8.90	83.00	10.10	85.00	10.40	81.00	10.00
216.00	7.60	110.00	8.80	110.00	8.70	100.00	8.90	180.00	8.20	100.00	8.90	106.00	9.00	101.00	8.80
281.00	1.90	177.00	8.30	177.00	8.40	171.00	8.30	200.00	7.10	182.00	8.30	179.00	8.30	176.00	8.30
301.00	1.70	211.00	7.00	211.00	7.00	194.00	7.60	217.00	8.00	207.00	7.20	207.00	7.30	196.00	7.40
352.00	1.80	222.00	7.30	221.00	7.40	206.00	7.00	271.00	2.30	217.00	8.00	211.00	7.90	207.00	7.90
402.00	1.30	268.00	2.80	267.00	2.70	217.00	7.80	318.00	1.20	232.00	7.10	238.00	6.60	236.00	6.40
451.00	.60	320.00	1.20	321.00	1.20	241.00	6.00	379.00	1.80	276.00	2.90	268.00	2.30	270.00	2.20
476.00	1.10	385.00	1.80	394.00	1.80	263.00	2.90	439.00	.70	287.00	2.20	321.00	1.30	322.00	1.20
577.00	0.00	441.00	.70	437.00	.90	319.00	1.40	515.00	.80	328.00	1.10	380.00	1.70	378.00	1.70
600.00	-.50	496.00	.70	492.00	1.00	377.00	1.60	608.00	-.20	383.00	1.70	435.00	.80	448.00	.80
		562.00	0.00	583.00	-.20	444.00	.70	677.00	0.00	439.00	.70	485.00	.90	484.00	1.10
						484.00	1.00	740.00	-1.00	514.00	.80	522.00	.80	544.00	.50
						548.00	.30			608.00	-.20	602.00	0.00	589.00	-.20
						570.00	-.20								

B-9

MYRTLE BEACH, CONN.  
DATUM IS MSL MEASUREMENT IS FT

PROFILE 4  
-----

DATE 630322	DATE 630405	DATE 630419	DATE 630503	DATE 630517	DATE 630531	DATE 630614	DATE 630628
SRVY 9	SRVY 10	SRVY 11	SRVY 12	SRVY 13	SRVY 14	SRVY 15	SRVY 16
TIME 1200	TIME 1200	TIME 1200	TIME 1200	TIME 1200	TIME 1200	TIME 1200	TIME 1200
-----	-----	-----	-----	-----	-----	-----	-----
-57.00	11.40	-61.00	11.40	-58.00	11.40	-60.00	11.30
-43.00	11.50	-40.00	11.60	-40.00	11.50	-39.00	11.50
1.00	9.90	0.00	9.90	1.00	9.90	0.00	10.00
60.00	10.90	60.00	10.90	54.00	11.00	55.00	10.80
86.00	9.90	86.00	10.00	88.00	9.90	86.00	10.00
100.00	8.90	100.00	8.90	106.00	8.90	101.00	8.80
182.00	8.20	181.00	8.20	147.00	8.60	151.00	8.70
202.00	7.30	190.00	7.60	197.00	7.70	196.00	7.90
207.00	8.00	201.00	8.10	226.00	7.70	221.00	8.90
220.00	8.00	221.00	7.70	271.00	2.20	270.00	8.00
270.00	2.00	266.00	3.00	324.00	1.10	332.00	8.00
321.00	1.20	270.00	2.10	395.00	1.80	393.00	3.90
393.00	1.70	321.00	1.30	443.00	.70	442.00	2.30
439.00	.80	391.00	1.70	505.00	.80	483.00	1.30
502.00	1.00	444.00	.80	602.00	-.20	587.00	1.90
552.00	0.00	520.00	.70			512.00	.90
602.00	-.40	602.00	-.20			613.00	-.20
							623.00
							623.00

PROFILE 4  
-----

DATE 630717	DATE 630820	DATE 630925	DATE 631022	DATE 631127	DATE 631204	DATE 631223	DATE 640123
SRVY 17	SRVY 18	SRVY 19	SRVY 20	SRVY 21	SRVY 22	SRVY 23	SRVY 24
TIME 1200	TIME 1200	TIME 1200	TIME 1200	TIME 1200	TIME 1200	TIME 1200	TIME 1200
-----	-----	-----	-----	-----	-----	-----	-----
-59.00	11.20	-63.00	11.40	-60.00	11.50	-60.00	11.40
0.00	10.10	-58.00	11.40	1.00	10.00	-39.00	11.10
51.00	10.50	1.00	10.00	49.00	10.70	50.00	10.90
84.00	9.90	52.00	10.40	83.00	10.00	102.00	9.90
102.00	9.00	84.00	10.00	94.00	9.00	151.00	8.80
105.00	8.60	102.00	8.90	152.00	8.40	201.00	8.60
186.00	8.00	186.00	8.10	184.00	8.40	252.00	9.40
202.00	8.90	215.00	8.50	201.00	9.10	268.00	8.60
218.00	8.10	268.00	2.20	262.00	2.40	302.00	8.90
267.00	2.10	301.00	1.30	295.00	1.90	402.00	4.00
305.00	1.30	354.00	1.50	302.00	.90	453.00	2.90
354.00	1.20	402.00	1.50	403.00	1.00	502.00	1.50
404.00	1.40	452.00	.90	453.00	.40	553.00	1.00
453.00	.90	505.00	.70	503.00	.40	583.00	1.10
504.00	.80	588.00	0.00	582.00	0.00	404.00	.80
552.00	.40					446.00	.90
602.00	0.00					502.00	.90
							601.00
							601.00

B-10

MYRTLE BEACH, CONN.  
DATUM IS MSL MEASUREMENT IS FT

PROFILE 4  
-----

DATE 640224 SRVY 25 TIME 1200	DATE 640420 SRVY 26 TIME 1200	DATE 640519 SRVY 27 TIME 1200	DATE 640618 SRVY 28 TIME 1200	DATE 640721 SRVY 29 TIME 1200	DATE 640916 SRVY 30 TIME 1200	DATE 640930 SRVY 31 TIME 1200	DATE 641202 SRVY 32 TIME 1200								
58.00	11.50	58.00	11.50	50.00	10.80	50.00	11.30	0.00	10.00	0.00	10.70	56.00	11.40	57.00	11.40
1.00	10.00	1.00	10.20	80.00	9.90	1.00	10.00	50.00	10.80	50.00	10.90	2.00	10.20	1.00	10.10
50.00	11.00	50.00	11.00	102.00	9.80	50.00	10.80	101.00	8.80	81.00	10.20	62.00	10.70	50.00	10.70
83.00	10.00	89.00	10.20	150.00	8.20	100.00	8.90	151.00	8.50	101.00	9.00	100.00	8.90	100.00	8.90
100.00	9.10	100.00	9.10	190.00	9.10	152.00	8.50	202.00	8.50	151.00	8.60	151.00	8.40	150.00	8.70
151.00	8.90	150.00	8.60	252.00	3.90	182.00	9.10	234.00	6.30	191.00	8.90	185.00	9.30	188.00	9.30
186.00	9.50	193.00	9.20	266.00	2.20	201.00	8.10	272.00	1.90	212.00	8.60	201.00	8.80	201.00	8.00
202.00	8.80	202.00	8.70	306.00	1.80	211.00	8.30	353.00	1.60	267.00	2.10	210.00	8.80	221.00	7.00
251.00	4.40	211.00	8.60	404.00	1.00	268.00	2.00	404.00	.90	353.00	1.70	218.00	7.30	270.00	2.20
268.00	2.40	269.00	2.40	453.00	.90	304.00	1.90	454.00	.80	403.00	1.10	263.00	2.50	353.00	1.60
352.00	1.30	352.00	1.40	506.00	1.20	406.00	1.10	503.00	1.30	454.00	.70	302.00	1.70	402.00	1.50
404.00	.90	402.00	1.30	554.00	0.00	454.00	.90	503.00	0.00	503.00	1.20	404.00	1.30	452.00	.70
454.00	1.00	452.00	1.10	606.00	.40	504.00	1.20	605.00	.50	554.00	0.00	455.00	.80	503.00	1.10
504.00	1.00	503.00	1.20	655.00	.50	555.00	0.00	655.00	.50	604.00	.60	503.00	1.20	553.00	0.00
554.00	.20	553.00	.20	703.00	-.50	605.00	.50	704.00	-.20			554.00	.10	603.00	.60
604.00	0.00	608.00	0.00			656.00	.10					604.00	.60	654.00	0.00
703.00	-.60	653.00	.30			706.00	-.50								
		704.00	-.60												

PROFILE 4  
-----

DATE 650211 SRVY 33 TIME 1200	DATE 650405 SRVY 34 TIME 1200	DATE 650607 SRVY 35 TIME 1200	DATE 650914 SRVY 36 TIME 1200	DATE 651220 SRVY 37 TIME 1200	DATE 660124 SRVY 38 TIME 1200	DATE 660505 SRVY 39 TIME 1200	DATE 660826 SRVY 41 TIME 1200
57.00	11.50	56.00	11.50	61.00	11.50	56.00	11.20
0.00	10.10	0.00	10.20	52.00	11.40	0.00	9.80
50.00	11.00	50.00	10.80	0.00	10.10	50.00	10.30
101.00	9.10	100.00	8.90	49.00	10.70	101.00	8.40
151.00	8.70	150.00	8.60	101.00	8.90	150.00	8.10
199.00	9.20	189.00	9.10	151.00	8.50	200.00	8.60
225.00	7.00	261.00	2.60	187.00	9.10	251.00	8.10
252.00	4.30	352.00	1.50	203.00	7.70	267.00	4.80
277.00	2.90	407.00	1.60	216.00	8.30	302.00	2.90
303.00	3.00	456.00	.90	258.00	2.60	352.00	2.30
353.00	1.60	502.00	1.10	353.00	1.40	404.00	1.80
404.00	1.60	554.00	-.50	409.00	1.30	439.00	1.40
454.00	.60	654.00	.60	443.00	.90	453.00	1.50
504.00	1.20	704.00	-.30	504.00	1.00	554.00	.70
554.00	0.00			555.00	-.50	604.00	.50
655.00	.40			655.00	.30	655.00	.30
705.00	-.50			705.00	-.60	705.00	-.30
						655.00	.40
						704.00	-.90

E-11

MYRTLE BEACH, CONN.  
 DATUM IS MSL MEASUREMENT IS FT

PROFILE 4  
 -----

DATE 661108	DATE 670206	DATE 670503	DATE 670602	DATE 670912	DATE 671226	DATE 680306	DATE 681125
SRVY 42	SRVY 43	SRVY 44	SRVY 45	SRVY 46	SRVY 47	SRVY 48	SRVY 49
TIME 1200	TIME 1200	TIME 1200	TIME 1200	TIME 1200	TIME 1200	TIME 1200	TIME 1200
-----	-----	-----	-----	-----	-----	-----	-----
-57.00	0.00	0.00	0.00	-55.00	-57.00	-67.00	0.00
0.00	49.00	50.00	50.00	35.00	35.00	0.00	14.00
50.00	100.00	103.00	103.00	50.00	49.00	51.00	50.00
83.00	144.00	151.00	141.00	132.00	132.00	131.00	90.00
103.00	162.00	180.00	201.00	181.00	182.00	184.00	100.00
151.00	183.00	202.00	252.00	202.00	201.00	201.00	150.00
186.00	204.00	213.00	302.00	263.00	251.00	252.00	168.00
202.00	272.00	266.00	353.00	306.00	302.00	257.00	200.00
252.00	304.00	303.00	403.00	357.00	354.00	302.00	237.00
272.00	353.00	353.00	454.00	406.00	406.00	352.00	250.00
353.00	403.00	402.00	503.00	507.00	455.00	365.00	300.00
402.00	453.00	452.00	553.00	552.00	506.00	503.00	350.00
493.00	504.00		604.00	605.00	554.00	554.00	376.00
553.00	554.00		654.00	654.00	655.00	653.00	400.00
	604.00						450.00
	655.00						500.00
							550.00

E-12



MYRTLE BEACH, CONN.  
 DATUM IS MSL MEASUREMENT IS FT

PROFILE 4  
 -----

DATE 690311	DATE 690610	DATE 690923	DATE 691230	DATE 700616	DATE 710419
SRVY 50	SRVY 51	SRVY 52	SRVY 53	SRVY 54	SRVY 55
TIME 1200	TIME 1200	TIME 1200	TIME 1200	TIME 1200	TIME 1200
-----	-----	-----	-----	-----	-----
0.00	10.20	0.00	10.10	0.00	10.30
50.00	10.50	50.00	10.70	50.00	10.50
86.00	9.60	100.00	9.90	80.00	10.10
100.00	10.00	143.00	10.00	100.00	10.70
121.00	10.10	163.00	9.00	109.00	10.90
150.00	8.80	184.00	9.00	122.00	10.00
174.00	9.10	200.00	8.80	150.00	8.70
200.00	5.70	230.00	5.00	200.00	3.60
224.00	2.70	250.00	2.80	175.00	2.70
250.00	1.90	300.00	2.20	200.00	2.60
300.00	1.10	350.00	1.10	207.00	2.10
350.00	2.40	400.00	2.80	225.00	.70
400.00	1.80	450.00	2.60	250.00	.80
450.00	1.10	500.00	2.20	275.00	2.80
500.00	1.10	550.00	1.10	300.00	2.70
550.00	.60	600.00	1.30	311.00	1.70
600.00	0.50		.80	326.00	.60
			.20	350.00	1.00
				400.00	1.00
				450.00	1.00
				500.00	1.00
				550.00	1.00
				600.00	1.00
				650.00	1.00
					1.30
					.60
					.20
					.20
					0.00

B-13

## APPENDIX C

### Profile Line Survey Data for Fairfield Beach

The survey data for Fairfield Beach are tabulated by profile line number and survey date (in the form YYMMDD). Distances are in feet from the profile line bench mark; elevations are in feet above or below MLW.

FAIRFIELD BEACH, CONNECTICUT  
 DATUM IS M.L.A. MEASUREMENT IS FT

PROFILE 1

DATE 621213 SRVY 2 TIME 1200	DATE 630102 SRVY 3 TIME 1200	DATE 630118 SRVY 4 TIME 1200	DATE 630131 SRVY 5 TIME 1200	DATE 630214 SRVY 6 TIME 1200	DATE 630228 SRVY 7 TIME 1200	DATE 630311 SRVY 8 TIME 1200	DATE 630322 SRVY 9 TIME 1200								
-201.00	9.60	-154.00	9.50	-150.00	9.50	-156.00	9.50	-134.00	11.00	-151.00	9.90	-151.00	9.80	-151.00	9.70
-154.00	9.70	-78.00	12.90	-40.00	13.40	-135.00	11.00	-114.00	12.90	-130.00	11.20	-134.00	11.30	-130.00	11.00
-78.00	12.90	-34.00	13.50	3.00	13.80	-49.00	12.50	-70.00	12.70	-79.00	12.80	-79.00	12.90	-43.00	13.40
-30.00	13.60	0.00	13.50	67.00	14.60	-54.00	13.40	-43.00	13.50	-42.00	13.60	-44.00	13.40	0.00	13.50
0.00	13.70	51.00	14.60	115.00	12.50	1.00	13.80	1.00	13.50	1.00	13.50	1.00	13.50	73.00	14.50
50.00	14.50	81.00	14.50	162.00	7.20	66.00	14.90	35.00	14.40	34.00	14.30	74.00	14.00	110.00	12.20
81.00	14.40	116.00	12.10	210.00	.30	94.00	13.90	68.00	14.90	76.00	14.70	115.00	12.50	217.00	.00
116.00	12.10	211.00	.70	251.00	0.00	157.00	8.00	108.00	12.60	117.00	12.00	216.00	.40	232.00	-1.20
211.00	2.90	264.00	-1.60			212.00	1.00	210.00	.10	154.00	0.00	256.00	-1.30		
226.00	-1.20					252.00	0.00	257.00	-1.50	221.00	.20				
										272.00	-1.70				

PROFILE 1

DATE 630405 SRVY 10 TIME 1200	DATE 630419 SRVY 11 TIME 1200	DATE 630503 SRVY 12 TIME 1200	DATE 630517 SRVY 13 TIME 1200	DATE 630531 SRVY 14 TIME 1200	DATE 630614 SRVY 15 TIME 1200	DATE 630628 SRVY 16 TIME 1200	DATE 630716 SRVY 17 TIME 1200								
-149.00	9.70	-151.00	9.70	-151.00	9.70	-151.00	9.80	-152.00	9.50	-153.00	9.40	-130.00	10.70	-1.00	13.10
-131.00	11.00	-131.00	10.90	-130.00	11.00	-131.00	10.90	-131.00	10.80	-131.00	10.80	-77.00	12.50	51.00	14.21
-41.00	13.60	-40.00	13.60	-81.00	12.60	-81.00	12.60	-81.00	12.50	-80.00	12.50	-33.00	13.30	70.00	14.20
0.00	13.40	0.00	13.50	-34.00	13.50	-35.00	13.40	-37.00	13.30	-38.00	13.20	3.00	13.50	101.00	12.90
71.00	14.50	65.00	14.50	1.00	13.60	3.00	13.60	72.00	14.60	71.00	14.50	52.00	14.10	150.00	9.00
111.00	12.20	116.00	12.10	70.00	14.50	70.00	14.60	112.00	12.40	120.00	11.30	76.00	14.40	201.00	.90
217.00	-1.10	216.00	.50	168.00	6.70	121.00	11.40	222.00	0.00	231.00	-1.10	123.00	11.20	230.00	-1.10
260.00	-1.80	227.00	0.00	227.00	0.00	166.00	6.60					170.00	5.60		
						219.00	.20					201.00	1.30		
						227.00	0.00					237.00	-1.00		

PROFILE 1

DATE 631019 SRVY 18 TIME 1200	DATE 630925 SRVY 19 TIME 1200	DATE 631022 SRVY 20 TIME 1200	DATE 631127 SRVY 21 TIME 1200	DATE 631204 SRVY 22 TIME 1200	DATE 631223 SRVY 23 TIME 1200	DATE 640122 SRVY 24 TIME 1200	DATE 640224 SRVY 25 TIME 1200								
5.00	13.50	5.00	13.70	6.00	13.60	5.00	13.40	7.00	13.60	6.00	13.60	6.00	13.50	6.00	13.50
51.00	14.30	51.00	14.50	74.00	14.50	51.00	14.10	50.00	14.30	51.00	14.30	51.00	14.50	50.00	14.50
72.00	14.30	72.00	14.50	107.00	12.60	75.00	14.30	79.00	14.30	78.00	14.30	92.00	14.00	76.00	14.50
101.00	13.00	102.00	13.00	153.00	8.50	102.00	12.90	102.00	12.60	101.00	13.20	119.00	11.90	116.00	12.10
151.00	8.40	152.00	8.40	202.00	2.00	142.00	10.10	110.00	11.90	139.00	8.70	153.00	8.80	154.00	8.60
202.00	1.90	214.00	.30	252.00	-1.10	202.00	2.40	141.00	9.40	201.00	2.00	202.00	1.90	202.00	1.60
231.00	-1.20	251.00	-1.30			251.00	-1.10	153.00	8.70	251.00	-1.40	251.00	-1.60	212.00	.60
254.00	-1.10							225.00	-1.20	302.00	-1.70	304.00	-1.70	253.00	-1.30

C-1

FAIRFIELD BEACH, CONNECTICUT  
 DATUM IS M.L.W. MEASUREMENT IS FT

PROFILE 1

DATE 640420	DATE 641520	DATE 640618	DATE 640721	DATE 640916	DATE 640929	DATE 641202	DATE 650211
SRVY 26	SRVY 27	SRVY 28	SRVY 29	SRVY 30	SRVY 31	SRVY 32	SRVY 33
TIME 1200	TIME 1200	TIME 1200	TIME 1200	TIME 1200	TIME 1200	TIME 1200	TIME 1200
6.00 13.80	6.00 13.80	4.00 13.50	5.00 13.60	51.00 14.40	10.00 14.10	8.00 13.80	7.00 13.80
51.00 14.60	51.00 14.40	52.00 14.20	51.00 14.50	80.00 14.40	80.00 14.40	50.00 14.40	52.00 14.40
70.00 14.60	78.00 14.30	78.00 14.30	77.00 14.30	103.00 13.30	103.00 13.20	82.00 14.40	76.00 14.30
107.00 13.00	115.00 13.00	102.00 13.00	102.00 13.00	152.00 9.10	153.00 8.90	106.00 12.90	104.00 13.10
153.00 8.80	152.00 9.10	151.00 9.00	152.00 9.00	202.00 2.10	199.00 2.10	153.00 9.00	151.00 10.10
203.00 2.40	203.00 2.20	202.00 2.40	202.00 2.40	253.00 -.50	252.00 -.40	203.00 2.70	202.00 2.80
251.00 -.40	253.00 -.40	252.00 -.40	252.00 -.40	300.00 -1.20	348.00 -1.90	252.00 -.10	253.00 -.50
352.00 -1.40	353.00 -1.20	351.00 -1.80		354.00 -1.90	403.00 -2.20	303.00 -1.00	
	352.00 -1.70			403.00 -2.20		353.00 -1.60	

PROFILE 1

DATE 650425	DATE 650607	DATE 650914	DATE 651220	DATE 660125	DATE 660506	DATE 660823	DATE 661110
SRVY 34	SRVY 35	SRVY 36	SRVY 37	SRVY 38	SRVY 39	SRVY 40	SRVY 41
TIME 1200	TIME 1200	TIME 1200	TIME 1200	TIME 1200	TIME 1200	TIME 1200	TIME 1200
6.00 13.80	5.00 13.80	3.00 14.00	5.00 13.80	4.00 13.90	3.00 13.90	3.00 13.70	3.00 14.00
50.00 14.30	51.00 14.40	51.00 14.60	49.00 14.50	51.00 14.60	51.00 14.50	51.00 14.40	50.00 14.60
83.00 14.30	100.00 13.20	81.00 14.40	81.00 14.30	95.00 14.60	92.00 14.40	91.00 14.40	91.00 14.60
140.00 10.10	154.00 8.90	115.00 12.30	141.00 10.50	103.00 14.10	103.00 13.80	161.00 8.50	103.00 14.00
158.00 8.30	166.00 7.70	151.00 9.30	152.00 9.50	154.00 9.10	152.00 9.40	203.00 2.60	151.00 9.70
207.00 2.30	208.00 2.50	204.00 1.90	221.00 .50	204.00 2.40	227.00 -.20	252.00 -1.20	206.00 2.60
220.00 .20	223.00 2.00	253.00 -.20	251.00 -.60	252.00 -.80	253.00 -.50	301.00 -1.90	222.00 0.00
252.00 -.50	252.00 -.60				301.00 -1.70		233.00 -.80

PROFILE 1

DATE 670228	DATE 670503	DATE 670602	DATE 670911	DATE 671226	DATE 680306	DATE 681125	DATE 690310
SRVY 42	SRVY 43	SRVY 44	SRVY 45	SRVY 46	SRVY 47	SRVY 48	SRVY 49
TIME 1200	TIME 1200	TIME 1200	TIME 1200	TIME 1200	TIME 1200	TIME 1200	TIME 1200
2.00 13.80	2.00 13.80	1.00 13.80	2.00 13.80	5.00 13.90	5.00 13.90	-1.00 13.70	0.00 13.80
51.00 14.70	51.00 14.90	51.00 14.60	52.00 14.40	52.00 14.50	50.00 14.50	5.00 15.30	50.00 14.70
101.00 14.00	101.00 14.10	102.00 14.00	82.00 14.50	102.00 14.00	80.00 14.60	6.00 13.90	84.00 14.30
151.00 9.90	151.00 10.00	152.00 9.10	162.00 9.20	152.00 10.00	100.00 13.80	50.00 14.50	100.00 13.40
202.00 2.90	203.00 3.20	218.00 0.00	232.00 -.70	203.00 4.10	133.00 11.10	79.00 14.50	135.00 11.70
243.00 -.90	228.00 .80	242.00 -1.70	243.00 -1.00	232.00 -.60	150.00 10.00	100.00 13.40	150.00 9.90
	242.00 -1.40			253.00 -1.10	189.00 5.00	128.00 12.30	175.00 6.70
					241.00 -1.00	150.00 10.20	200.00 3.40
						200.00 3.30	220.00 .70
						220.00 0.00	250.00 -1.10
						250.00 -1.30	

C-2

FAIRFIELD BEACH, CONNECTICUT  
 DATUM IS M.L.W. MEASUREMENT IS FT

PROFILE 1  
 -----

DATE	SRVY	TIME	DATE	SRVY	TIME	DATE	SRVY	TIME	DATE	SRVY	TIME	DATE	SRVY	TIME
690610	50	1200	690923	51	1200	691230	52	1200	700616	53	1200	710420	54	1200
0.00	13.80		0.00	13.70		1.00	13.70		1.00	13.60		0.00	13.60	
50.00	14.50		50.00	14.50		50.00	14.50		50.00	13.90		25.00	14.10	
85.00	14.10		50.00	14.50		50.00	14.50		50.00	14.40		50.00	14.30	
100.00	13.40		100.00	13.50		100.00	13.70		100.00	13.40		75.00	14.20	
138.00	11.40		135.00	11.40		125.00	12.50		136.00	11.50		100.00	13.50	
150.00	9.90		150.00	12.20		150.00	10.00		150.00	9.80		125.00	12.30	
163.00	8.60		160.00	9.10		175.00	6.80		200.00	3.70		150.00	9.90	
190.00	4.00		190.00	5.10		200.00	2.90		227.00	-0.10		171.00	8.40	
200.00	3.70		200.00	4.10		214.00	.80					175.00	7.70	
230.00	.90		225.00	1.40		230.00	-0.50					200.00	4.30	
250.00	-1.10		250.00	-0.80								225.00	0.00	
250.00	-1.10													

PROFILE 2  
 -----

DATE	SRVY	TIME	DATE	SRVY	TIME	DATE	SRVY	TIME	DATE	SRVY	TIME	DATE	SRVY	TIME	DATE	SRVY	TIME							
621113	1	1200	621213	2	1200	630102	3	1200	630118	4	1200	630131	5	1200	630214	6	1200	630228	7	1200	630311	8	1200	
0.00	12.30		-141.00	12.00		-130.00	12.70		-139.00	12.60		-130.00	12.50		-87.00	14.30		-101.00	13.90		-115.00	12.90		
51.00	10.80		-90.00	14.50		-89.00	14.40		-91.00	14.40		-91.00	14.40		-44.00	13.90		-44.00	14.40		-91.00	14.30		
151.00	5.00		-40.00	13.80		-41.00	13.70		-40.00	13.70		-40.00	13.70		-9.00	12.90		-42.00	13.80		-21.00	13.40		
201.00	1.50		2.00	12.50		40.00	11.00		121.00	0.90		51.00	10.10		3.00	12.10		42.00	10.70		136.00	0.50		
251.00	-1.00		44.00	10.70		75.00	8.90		143.00	5.00		125.00	6.50		103.00	7.80		109.00	7.70		156.00	4.30		
			91.00	8.10		112.00	8.20		185.00	2.70		201.00	1.60		111.00	7.90		185.00	2.50		257.00	-0.80		
			111.00	8.20		144.00	5.10		207.00	1.20		251.00	-0.80		127.00	7.30		252.00	-0.90					
			143.00	4.30		211.00	.90		251.00	-0.70					178.00	2.50								
			202.00	1.50		238.00	-0.10								251.00	-0.80								
			236.00	-0.10																				

PROFILE 2  
 -----

DATE	SRVY	TIME	DATE	SRVY	TIME	DATE	SRVY	TIME	DATE	SRVY	TIME	DATE	SRVY	TIME	DATE	SRVY	TIME	DATE	SRVY	TIME			
630322	9	1200	630405	10	1200	630419	11	1200	630503	12	1200	630517	13	1200	630531	14	1200	630614	15	1200	630628	16	1200
-137.00	12.50		-131.00	12.60		-131.00	12.40		-132.00	12.40		-126.00	12.60		-128.00	12.70		-130.00	12.60		-126.00	12.20	
-100.00	13.70		-100.00	13.90		-86.00	14.30		-89.00	14.30		-85.00	14.30		-90.00	14.30		-90.00	14.20		-81.00	13.90	
-91.00	14.30		-90.00	14.60		-15.00	13.10		-41.00	13.50		-41.00	13.70		-30.00	13.60		-40.00	13.50		-21.00	13.20	
-40.00	13.70		-15.00	13.30		1.00	12.00		92.00	8.40		71.00	9.60		5.00	11.90		106.00	8.40		114.00	8.70	
91.00	8.30		2.00	12.20		90.00	8.40		103.00	8.60		115.00	7.10		75.00	9.40		125.00	0.10		126.00	5.70	
105.00	4.30		103.00	8.20		115.00	7.90		117.00	6.70		137.00	5.10		118.00	7.10		178.00	3.20		203.00	.90	
158.00	4.30		150.00	4.40		140.00	5.00		142.00	5.00		235.00	0.00		195.00	1.80		248.00	-0.30		236.00	-0.40	
207.00	1.10		242.00	-0.40		208.00	1.00		233.00	-0.10					231.00	0.00							

C-3





FAYFIELD BEACH, CONNECTICUT  
 DATUM IS M.L.W. MEASUREMENT IS FT

PROFILE 3  
 -----

DATE 621113	DATE 621213	DATE 630102	DATE 630118	DATE 630131	DATE 630214	DATE 630228	DATE 630311								
SRVY 1	SRVY 2	SRVY 3	SRVY 4	SRVY 5	SRVY 6	SRVY 7	SRVY 8								
TIME 1200	TIME 1200	TIME 1200	TIME 1200	TIME 1200	TIME 1200	TIME 1200	TIME 1200								
1.00	12.40	-130.00	10.80	-129.00	10.90	-122.00	11.20	-131.00	11.90	-130.00	11.20	-130.00	11.20	-130.00	10.90
51.00	4.40	-50.00	12.00	-46.00	11.80	-19.00	12.90	-50.00	12.50	-20.00	13.00	-20.00	13.00	-18.00	12.00
100.00	4.60	-15.00	13.10	-14.00	12.80	1.00	12.40	-20.00	12.90	2.00	12.30	1.00	12.40	2.00	12.20
202.00	2.90	51.00	9.10	1.00	12.30	47.00	9.90	3.00	12.30	45.00	9.80	47.00	9.70	70.00	7.50
251.00	1.20	101.00	4.00	87.00	5.80	92.00	4.60	45.00	9.90	49.00	9.90	96.00	5.00	99.00	4.10
301.00	1.30	122.00	4.00	96.00	4.50	111.00	3.80	97.00	4.50	94.00	4.30	114.00	4.30	116.00	3.80
351.00	-0.70	159.00	4.20	158.00	4.10	159.00	4.00	151.00	4.40	117.00	4.00	147.00	4.90	152.00	4.10
		254.00	1.80	214.00	2.30	246.00	1.80	247.00	1.70	146.00	4.20	242.00	2.20	227.00	1.80
		300.00	1.80	308.00	1.00	290.00	1.90	277.00	1.90	246.00	0.60	286.00	2.20	277.00	1.80
		326.00	-0.50	359.00	-0.70	326.00	0.50	361.00	-0.60	282.00	1.70	378.00	-1.20	374.00	-1.00
										363.00	-0.80				

PROFILE 3  
 -----

DATE 630322	DATE 630405	DATE 630419	DATE 630503	DATE 630517	DATE 630531	DATE 630614	DATE 630628								
SRVY 9	SRVY 10	SRVY 11	SRVY 12	SRVY 13	SRVY 14	SRVY 15	SRVY 16								
TIME 1200	TIME 1200	TIME 1200	TIME 1200	TIME 1200	TIME 1200	TIME 1200	TIME 1200								
-130.00	11.00	-130.00	11.00	-129.00	11.00	-131.00	11.00	-128.00	11.10	-128.00	11.10	-130.00	10.80		
-49.00	12.50	-20.00	12.90	-19.00	12.80	-99.00	11.30	-49.00	12.20	-49.00	12.30	-96.00	11.40	-91.00	11.60
-18.00	12.90	3.00	12.20	40.00	10.30	-24.00	12.80	-24.00	12.80	-23.00	13.00	-50.00	12.10	-19.00	12.50
2.00	12.30	24.00	10.50	50.00	8.90	2.00	12.10	0.00	12.20	0.00	12.10	-28.00	12.80	50.00	9.10
60.00	9.00	47.00	9.80	71.00	7.90	42.00	9.80	40.00	9.80	56.00	8.80	1.00	12.20	92.00	4.10
97.00	4.40	61.00	8.10	98.00	4.50	96.00	4.90	70.00	7.30	95.00	4.50	51.00	9.50	104.00	3.50
115.00	3.90	92.00	4.80	115.00	3.90	100.00	4.40	96.00	4.20	110.00	3.90	94.00	4.20	153.00	4.10
136.00	4.50	108.00	3.90	134.00	4.50	113.00	4.00	113.00	3.80	153.00	4.00	111.00	3.90	221.00	1.90
236.00	1.80	162.00	4.10	230.00	2.00	141.00	4.20	147.00	4.10	228.00	2.00	151.00	4.30	254.00	2.10
272.00	2.00	236.00	1.80	265.00	2.30	233.00	1.90	226.00	1.90	264.00	1.90	227.00	2.10	356.00	-0.80
352.00	-0.20	262.00	2.20	303.00	0.90	270.00	1.90	268.00	2.00	339.00	0.00	257.00	2.20		
		351.00	-0.20	350.00	-0.20	357.00	-0.20	338.00	-0.10			346.00	-0.10		



FAIRFIELD REACH, CONNECTICUT  
DATUM IS M.L.W. MEASUREMENT IS FT

PROFILE 3

DATE 630716	DATE 630819	DATE 630925	DATE 631022	DATE 631127	DATE 631204	DATE 631223	DATE 640122
SRVY 17	SRVY 18	SRVY 19	SRVY 20	SRVY 21	SRVY 22	SRVY 23	SRVY 24
TIME 1200	TIME 1200	TIME 1200	TIME 1200	TIME 1200	TIME 1200	TIME 1200	TIME 1200
2.00	11.40	1.00	12.20	1.00	12.20	0.00	12.20
50.00	9.50	52.00	9.40	51.00	9.20	50.00	9.20
93.00	8.00	92.00	8.30	92.00	8.40	95.00	8.40
101.00	8.00	101.00	8.00	100.00	8.30	134.00	8.40
152.00	8.80	153.00	8.10	132.00	8.40	204.00	2.50
202.00	2.10	202.00	2.50	211.00	2.50	252.00	2.00
253.00	.80	255.00	2.10	252.00	2.00	340.00	.40
337.00	.40	337.00	.10	312.00	.90	353.00	-.30
351.00	-.50	350.00	-.50	337.00	.50		
				352.00	-.40		
						302.00	1.20
						353.00	-.40
						393.00	-2.50
						377.00	-2.00

PROFILE 3

DATE 640224	DATE 640420	DATE 640520	DATE 640618	DATE 640721	DATE 640916	DATE 640929	DATE 641202
SRVY 25	SRVY 26	SRVY 27	SRVY 28	SRVY 29	SRVY 30	SRVY 31	SRVY 32
TIME 1200	TIME 1200	TIME 1200	TIME 1200	TIME 1200	TIME 1200	TIME 1200	TIME 1200
0.00	12.20	1.00	12.20	1.00	12.20	0.00	12.10
51.00	8.90	53.00	8.70	52.00	8.70	50.00	9.20
81.00	4.90	84.00	4.90	81.00	5.10	86.00	4.70
204.00	2.80	189.00	2.90	171.00	4.60	151.00	3.50
302.00	1.50	251.00	2.20	187.00	3.20	252.00	2.10
352.00	-.60	352.00	-.40	252.00	2.30	310.00	.90
				112.00	1.00	352.00	-.30
				352.00	-.40		
						304.00	1.00
						351.00	-.30
						304.00	1.00
						353.00	-.30
						350.00	0.00

PROFILE 3

DATE 650211	DATE 650405	DATE 650607	DATE 650914	DATE 651220	DATE 660125	DATE 660506	DATE 660823
SRVY 33	SRVY 34	SRVY 35	SRVY 36	SRVY 37	SRVY 38	SRVY 39	SRVY 40
TIME 1200	TIME 1200	TIME 1200	TIME 1200	TIME 1200	TIME 1200	TIME 1200	TIME 1200
1.00	12.10	1.00	12.30	1.00	12.10	1.00	11.10
28.00	10.80	30.00	11.10	34.00	10.40	29.00	11.10
53.00	8.90	52.00	8.40	51.00	8.30	105.00	4.00
80.00	6.50	81.00	6.70	83.00	8.50	154.00	3.50
108.00	5.00	102.00	4.90	91.00	4.70	202.00	2.50
151.00	3.20	152.00	3.10	210.00	2.40	255.00	2.00
202.00	2.50	302.00	1.50	303.00	1.40	303.00	.60
251.00	2.10	351.00	-.10	353.00	-.10	351.00	0.00
349.00	-.10						
						403.00	-2.50
						398.00	-2.30

C-7

FAIRFIELD BEACH, CONNECTICUT  
 DATUM IS M.L.W. MEASUREMENT IS FT

PROFILE 3  
 -----

DATE 661110 SRVY 41 TIME 1200	DATE 670208 SRVY 42 TIME 1200	DATE 670503 SRVY 43 TIME 1200	DATE 670602 SRVY 44 TIME 1200	DATE 670911 SRVY 45 TIME 1200	DATE 671226 SRVY 46 TIME 1200	DATE 680306 SRVY 47 TIME 1200	DATE 681125 SRVY 48 TIME 1200								
0.00	11.40	0.00	11.50	-1.00	11.10	0.00	11.70	0.00	11.80	0.00	11.90	0.00	11.60	0.00	10.30
25.00	9.80	51.00	7.80	28.00	10.40	20.00	11.10	49.00	8.70	11.00	11.40	19.00	10.60	50.00	8.20
52.00	9.00	86.00	7.10	50.00	8.00	28.00	9.80	61.00	8.50	51.00	7.90	50.00	8.00	60.00	7.60
59.00	8.20	102.00	6.00	151.00	2.90	50.00	8.90	99.00	4.90	101.00	5.30	80.00	7.10	63.00	8.00
101.00	5.30	152.00	3.30	196.00	1.60	127.00	3.00	131.00	3.00	152.00	2.10	123.00	3.00	100.00	5.30
142.00	3.10	201.00	1.30	201.00	1.80	176.00	2.00	152.00	2.30	182.00	1.60	151.00	2.60	127.00	3.70
152.00	3.30	217.00	1.00	252.00	2.10	204.00	2.30	201.00	2.10	205.00	2.00	201.00	2.30	150.00	3.60
188.00	3.90	250.00	2.10	303.00	1.40	253.00	1.90	226.00	2.60	252.00	2.10	251.00	1.90	200.00	2.10
251.00	.90	302.00	.90	353.00	0.00	303.00	1.30	252.00	2.30	354.00	-.40	301.00	1.10	250.00	.60
		352.00	-.90	383.00	-1.30	353.00	.10	303.00	.90	404.00	-1.10	352.00	-.40	300.00	1.20
						382.00	-1.20	353.00	-.10			376.00	-1.30	340.00	0.00
								374.00	-1.10						

PROFILE 3  
 -----

DATE 690310 SRVY 49 TIME 1200	DATE 690610 SRVY 50 TIME 1200	DATE 690923 SRVY 51 TIME 1200	DATE 691230 SRVY 52 TIME 1200	DATE 700616 SRVY 53 TIME 1200	DATE 710420 SRVY 54 TIME 1200						
0.00	10.20	0.00	10.30	0.00	10.10	0.00	10.00	0.00	10.40	-50.00	11.90
50.00	8.20	30.00	9.50	25.00	9.60	50.00	8.00	30.00	8.70	-30.00	11.80
75.00	7.80	50.00	8.50	50.00	9.30	43.00	6.60	55.00	8.80	-25.00	12.00
90.00	6.10	56.00	8.20	75.00	6.40	100.00	5.80	72.00	7.90	0.00	10.50
100.00	5.50	100.00	4.70	100.00	5.20	130.00	3.20	100.00	4.60	5.00	10.20
125.00	3.80	150.00	2.60	150.00	2.50	150.00	2.20	127.00	3.00	25.00	8.70
150.00	2.70	200.00	1.60	200.00	1.90	163.00	1.90	150.00	2.60	50.00	7.80
200.00	1.70	250.00	2.40	210.00	2.60	183.00	3.00	200.00	2.40	75.00	6.60
250.00	2.20	300.00	1.50	250.00	2.40	200.00	3.10	230.00	2.80	100.00	5.60
300.00	1.40	350.00	-.70	300.00	1.70	250.00	2.40	250.00	2.40	125.00	4.20
340.00	-.30			350.00	-.80	300.00	1.30	300.00	.90	150.00	3.10
						340.00	-.30	350.00	-.50	175.00	2.50
										200.00	2.00
										225.00	1.70
										250.00	1.70
										275.00	1.60
										300.00	1.40
										325.00	.90
										350.00	-.50

## APPENDIX D

### Above Mean Sea Level Unit Volume Change for Myrtle and Fairfield Beaches

The unit volume is the volume per unit width (cubic meters per meter) bounded by a horizontal line passing through the MSL position, a vertical line at the backshore datum and the measured beach profile. This appendix shows the above MSL volume at successive beach profile measurements relative to the mean above MSL unit volume.

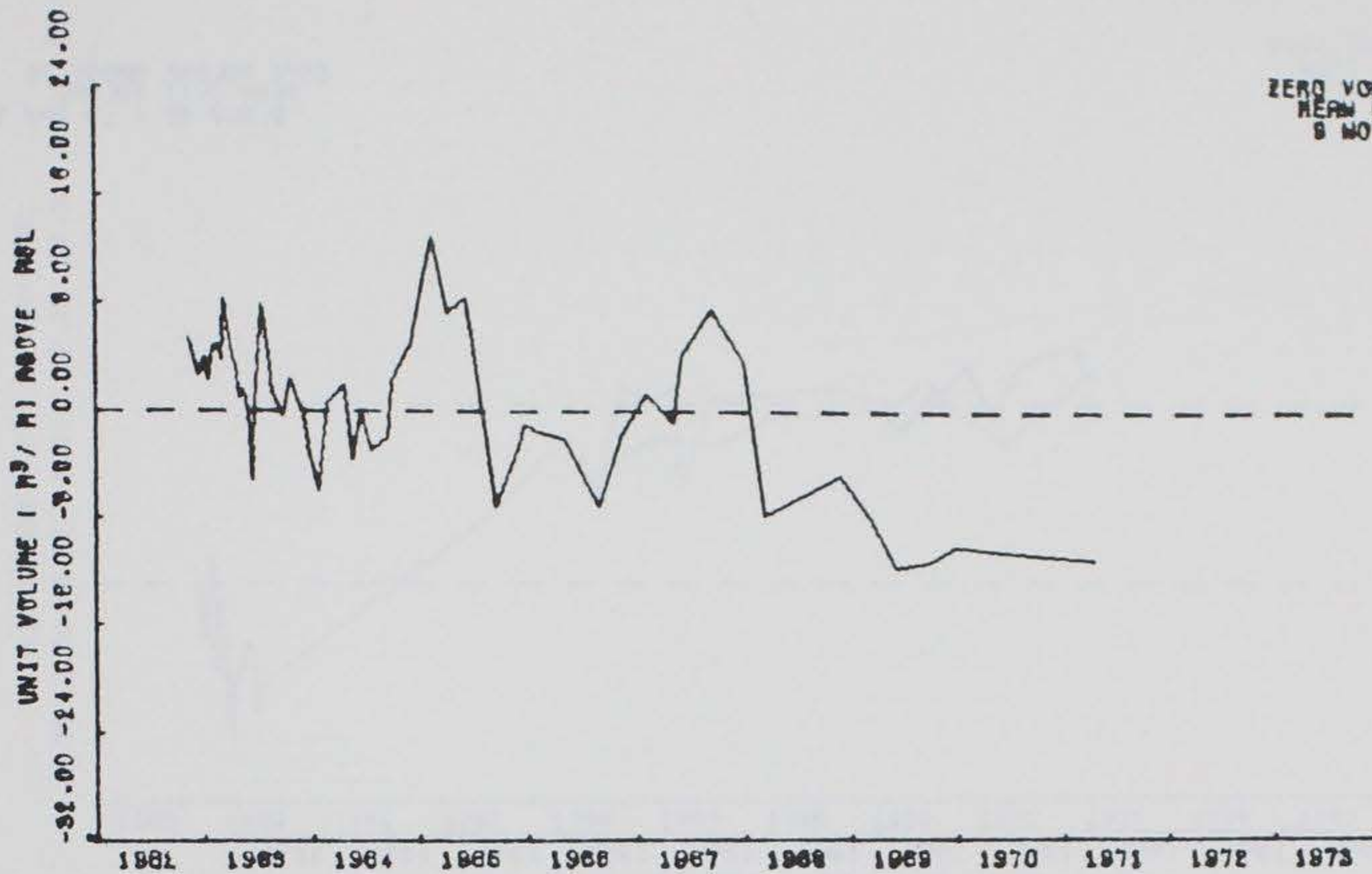

UNIT VOLUME CHANGES FOR PROFILE LINE 1 AT  
BEACH PROFILES MYRTLE BEACH CONNECTICUT

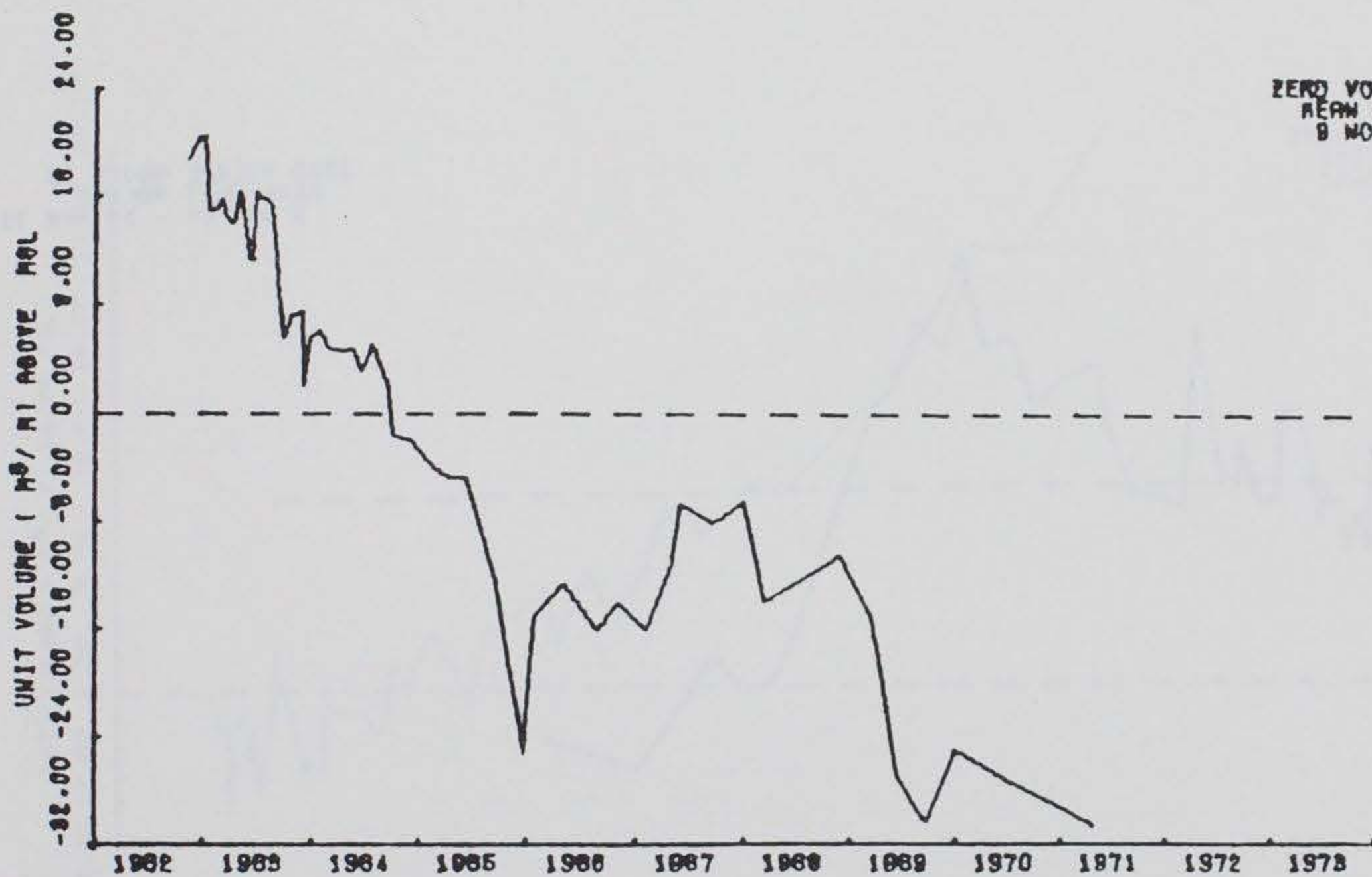

UNIT VOLUME CHANGES FOR PROFILE LINE 2 AT  
BEACH PROFILES MYRTLE BEACH CONNECTICUT

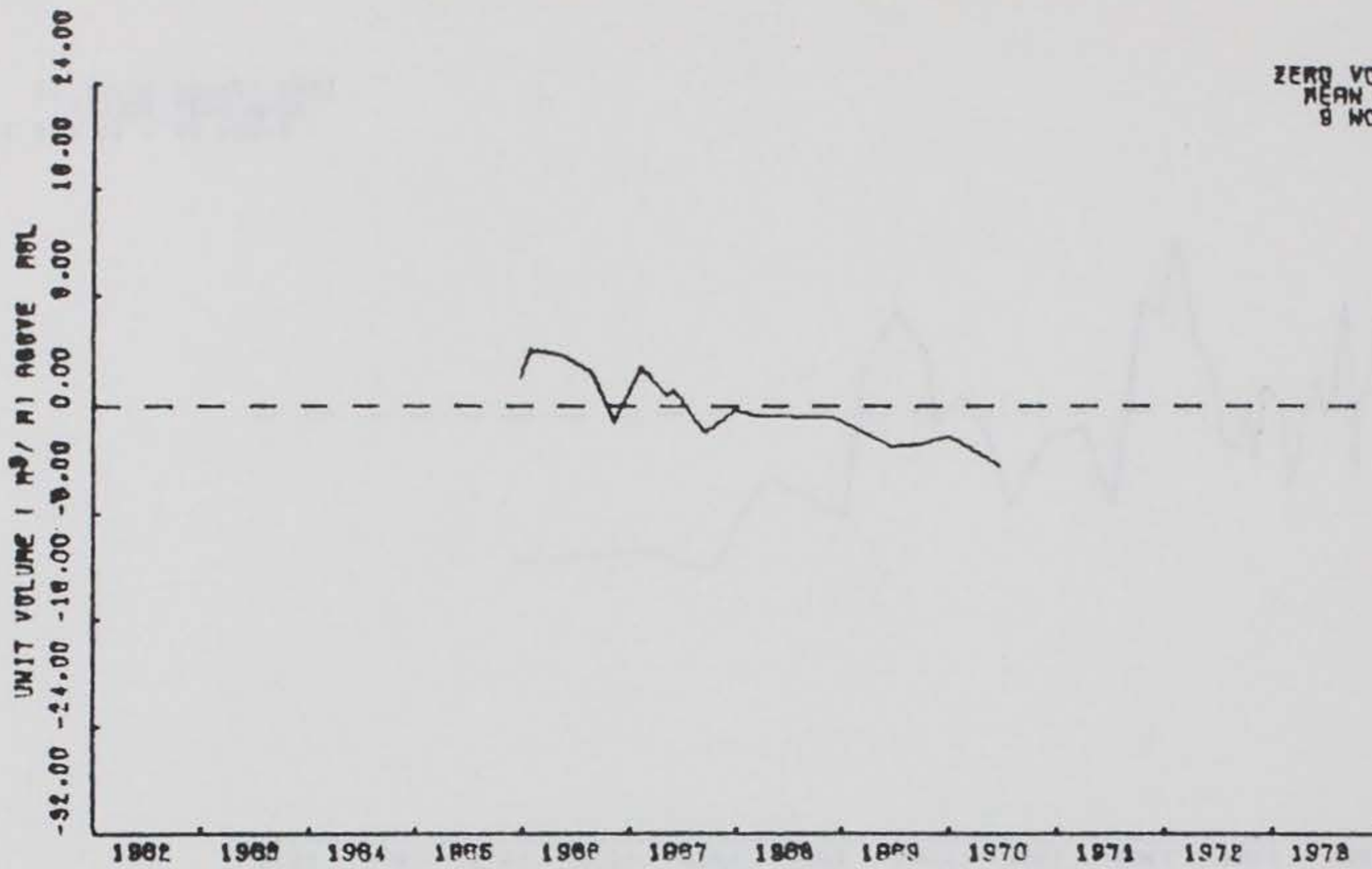

ZERO VOLUME ABOVE IS  
 MEAN UNIT VOLUME  
 8 NOV 62 - 18 APR 71

UNIT VOLUME CHANGES FOR PROFILE LINE 3 AT  
 BEACH PROFILES MYRTLE BEACH CONNECTICUT

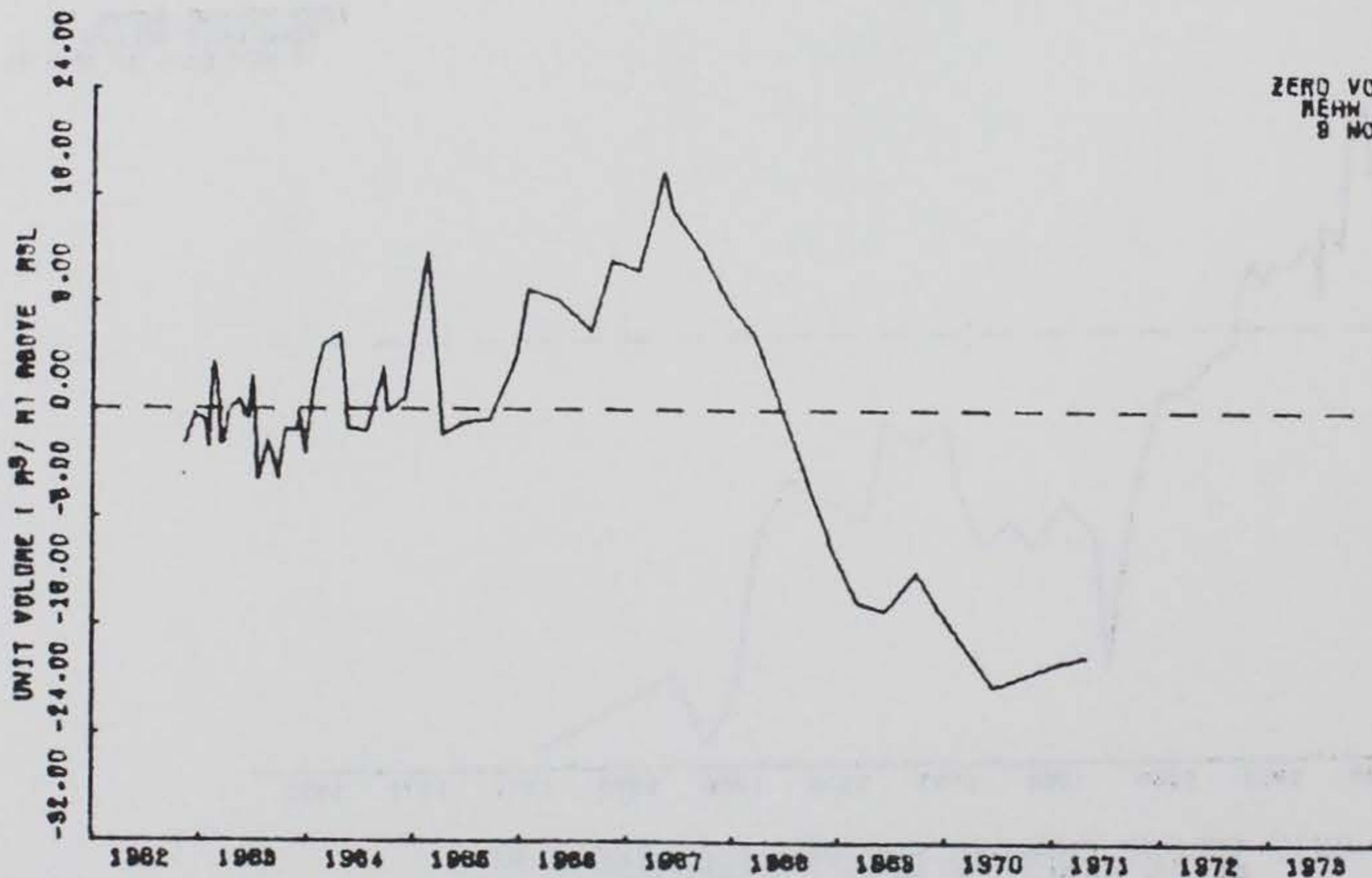

ZERO VOLUME ABOVE IS  
 MEAN UNIT VOLUME  
 8 NOV 62 - 18 APR 71

UNIT VOLUME CHANGES FOR PROFILE LINE 4 AT  
 BEACH PROFILES MYRTLE BEACH CONNECTICUT

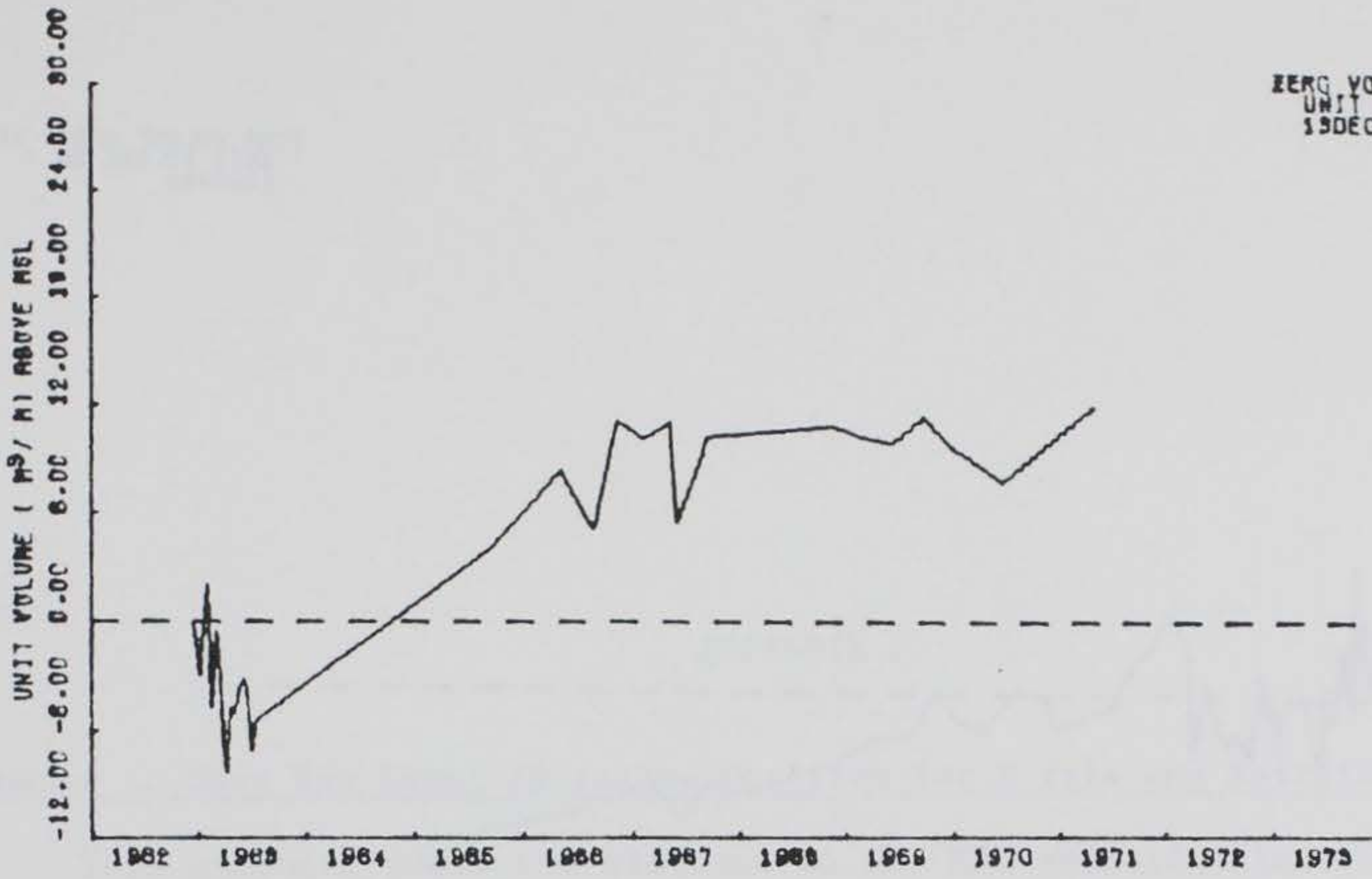

ZERO VOLUME ABOVE IS  
UNIT VOLUME ON  
19DEC62

UNIT VOLUME CHANGES FOR PROFILE LINE 1 AT  
FAIRFIELD BEACH, CONNECTICUT

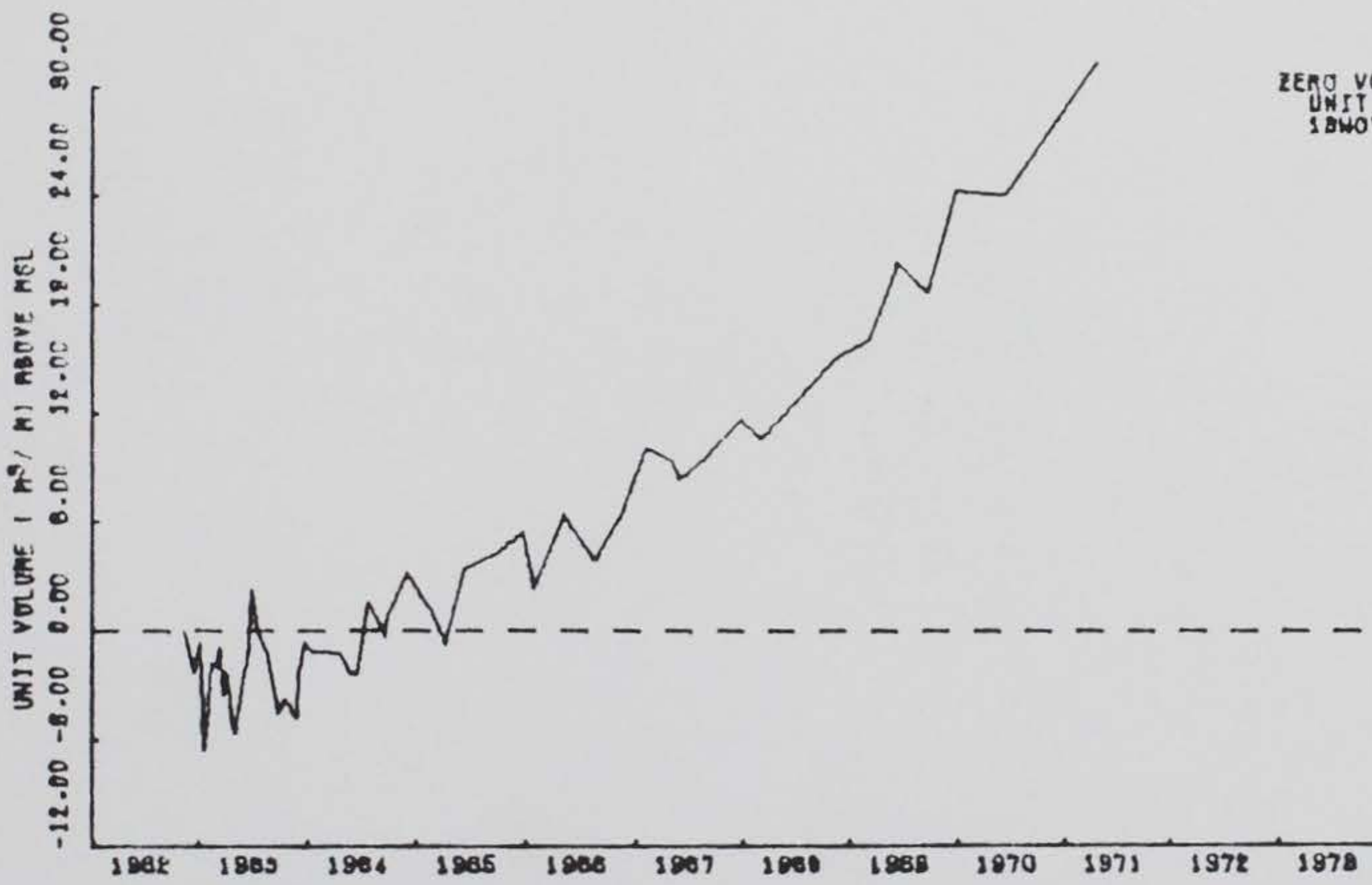

ZERO VOLUME ABOVE IS  
UNIT VOLUME ON  
18NOV62

UNIT VOLUME CHANGES FOR PROFILE LINE 2 AT  
FAIRFIELD BEACH, CONNECTICUT

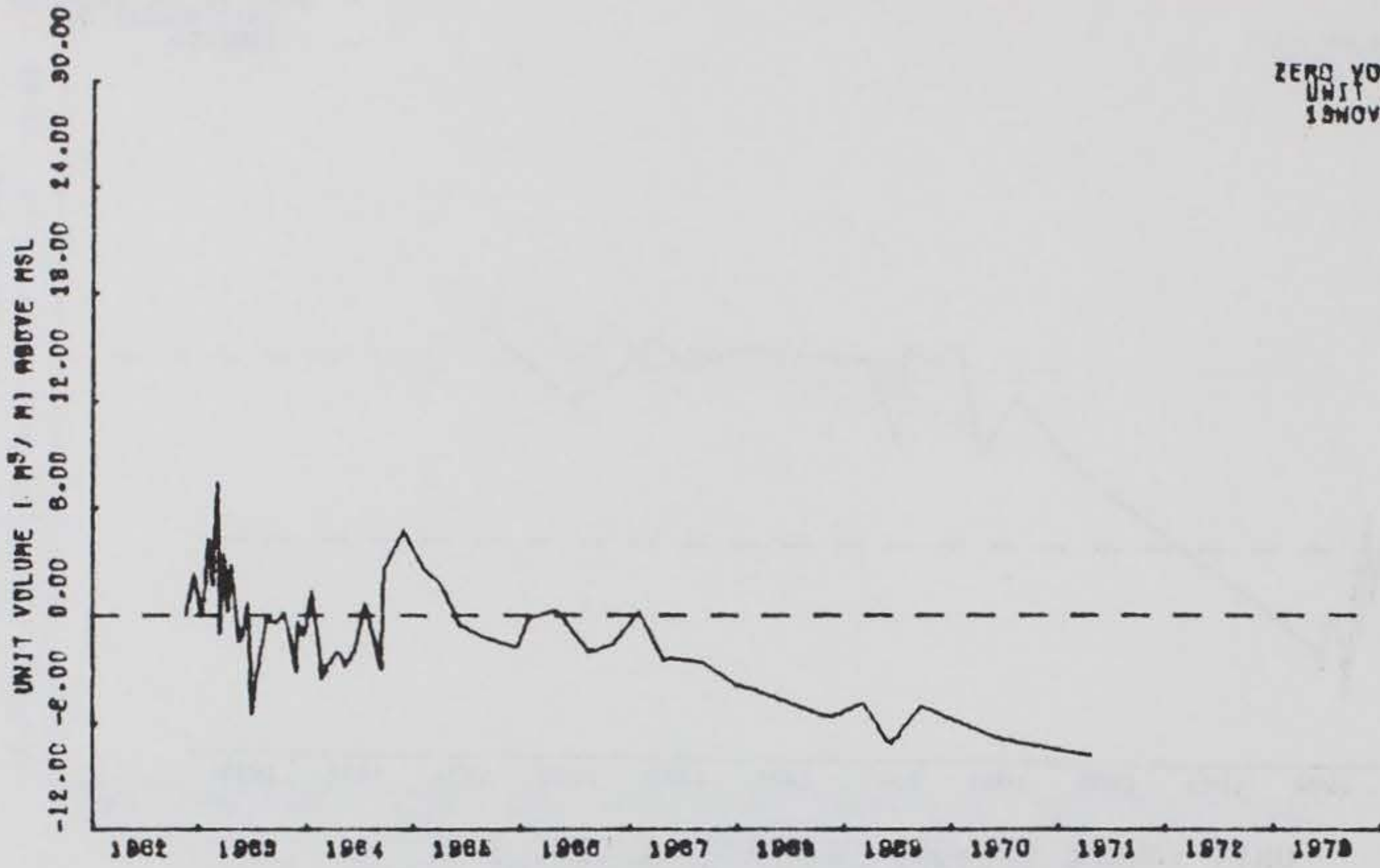

ZERO VOLUME ABOVE IS  
UNIT VOLUME ON  
19NOV62

UNIT VOLUME CHANGES FOR PROFILE LINE 3 AT  
FAIRFIELD BEACH, CONNECTICUT

APPENDIX E

Change in Mean Sea Level Shoreline Position for Myrtle and Fairfield Beaches

This appendix shows the distance to the MSL shoreline intercept relative to its position on the date of the first beach profile survey.



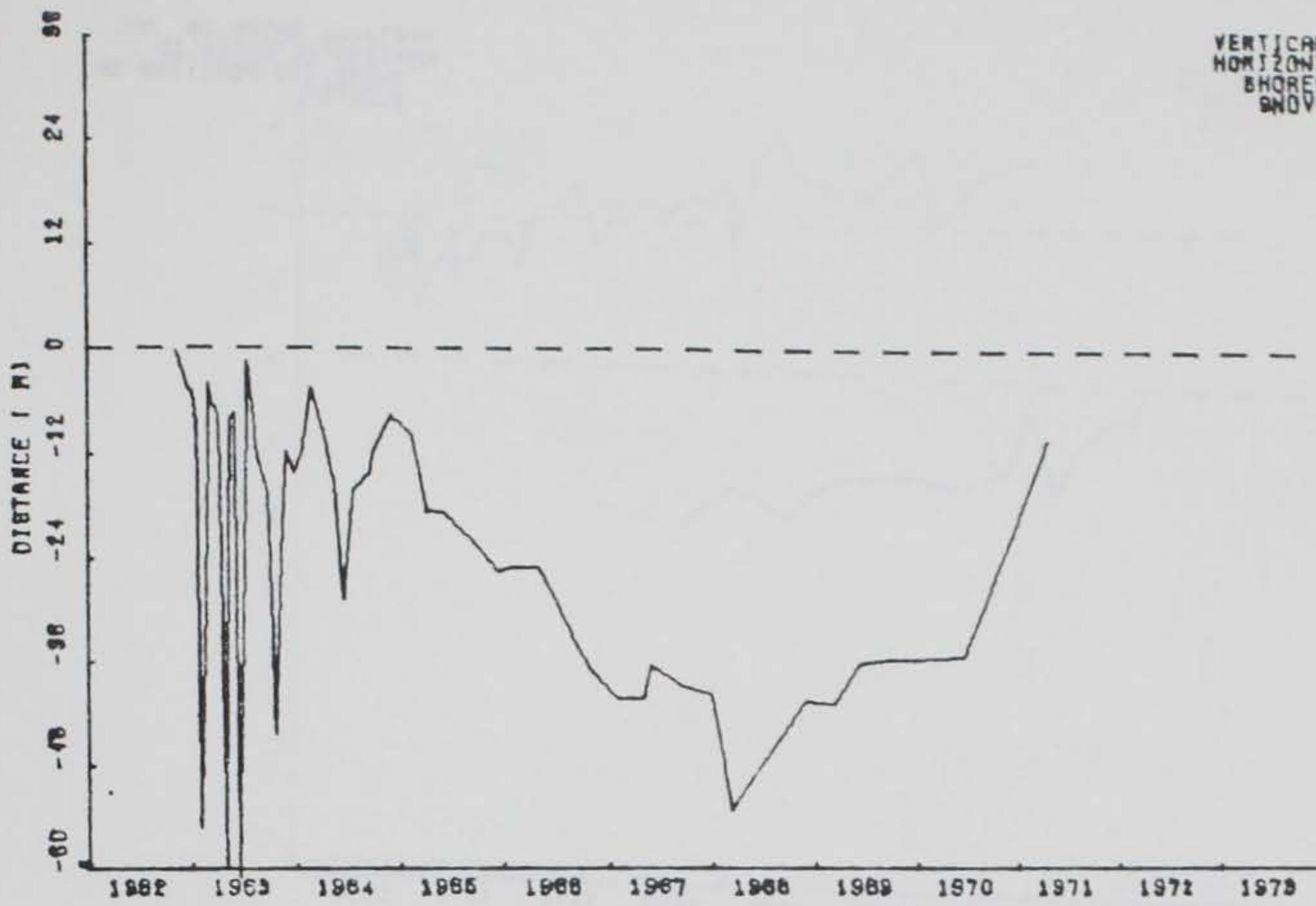

CHANGE IN DISTANCE TO SHOBE LINE AT  
PROFILE LINE 1 BEACH PROFILES MYRTLE BEACH CONN.

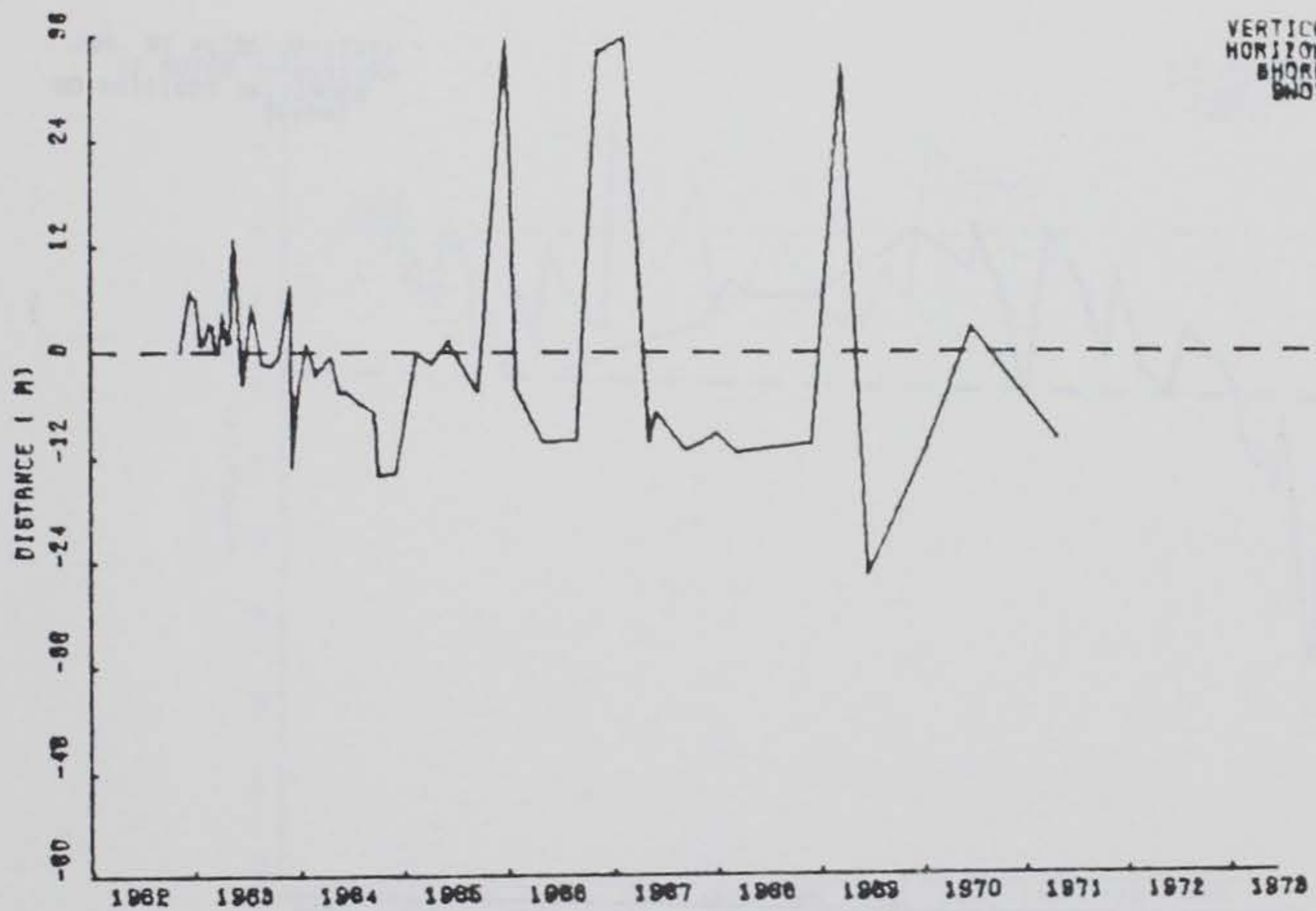

CHANGE IN DISTANCE TO SHOBE LINE AT  
PROFILE LINE 2 BEACH PROFILES MYRTLE BEACH CONN.

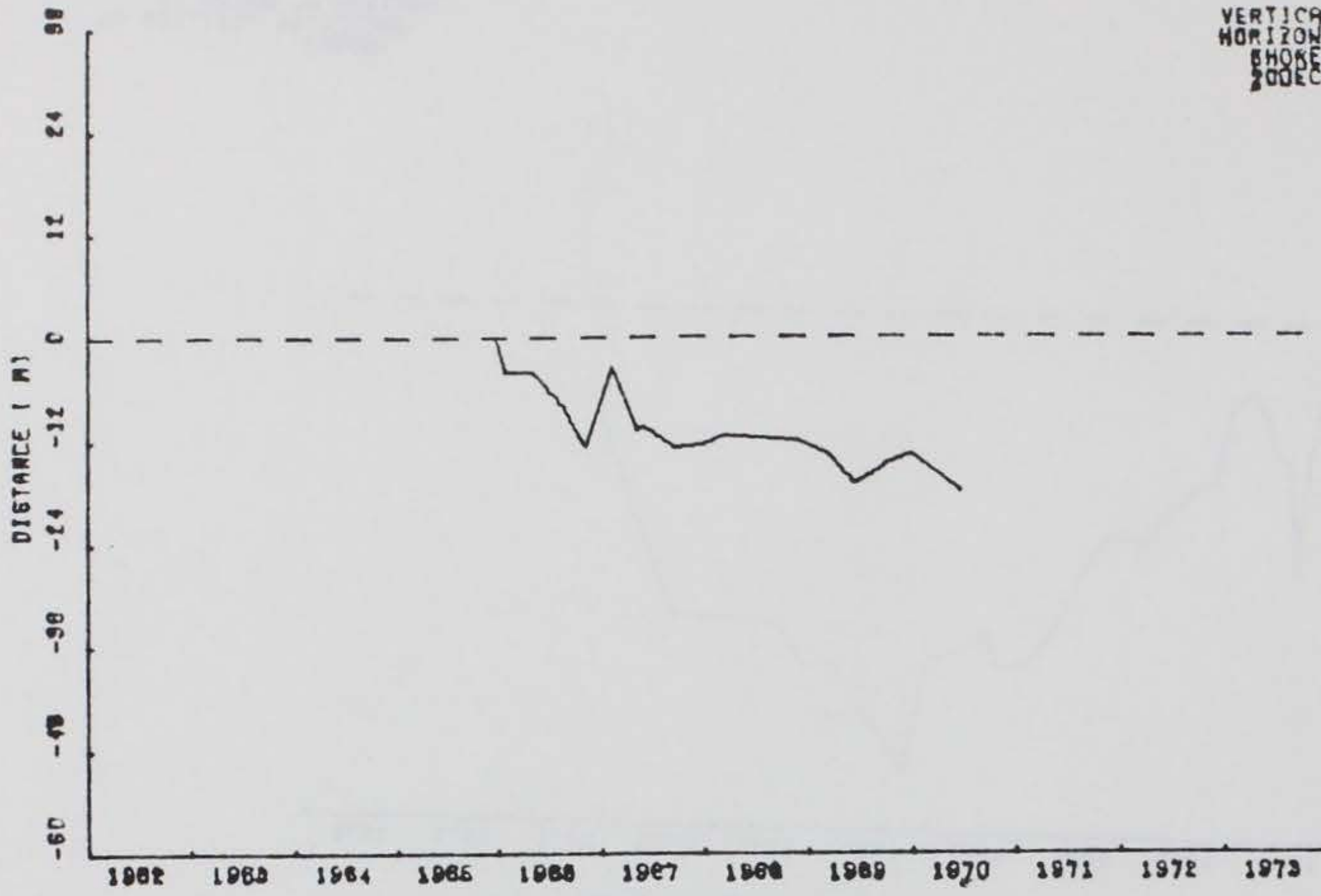

CHANGE IN DISTANCE TO SHORELINE AT  
PROFILE LINE 3 BEACH PROFILES MYRTLE BEACH CONN.

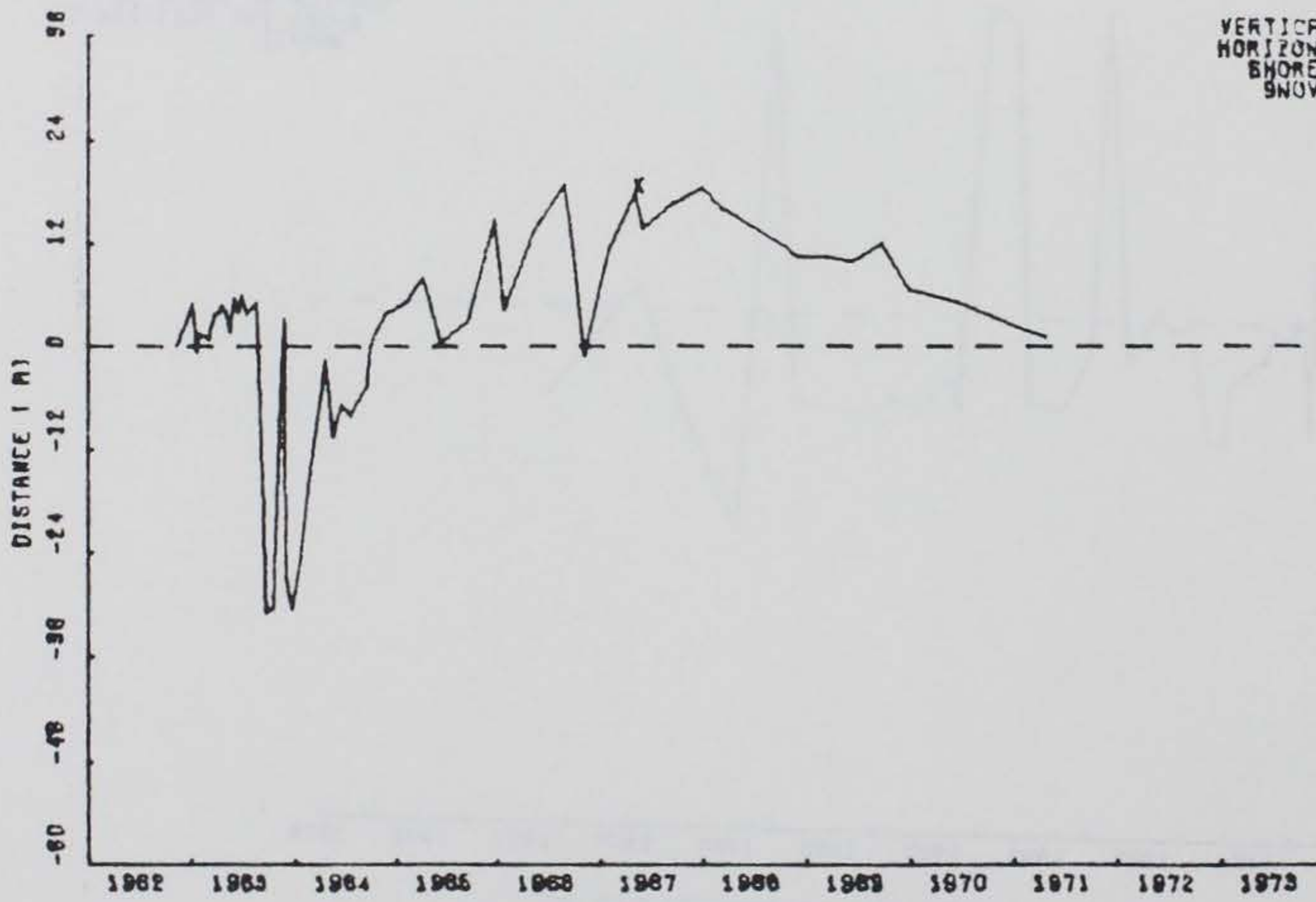

CHANGE IN DISTANCE TO SHORELINE AT  
PROFILE LINE 4 BEACH PROFILES MYRTLE BEACH CONN.

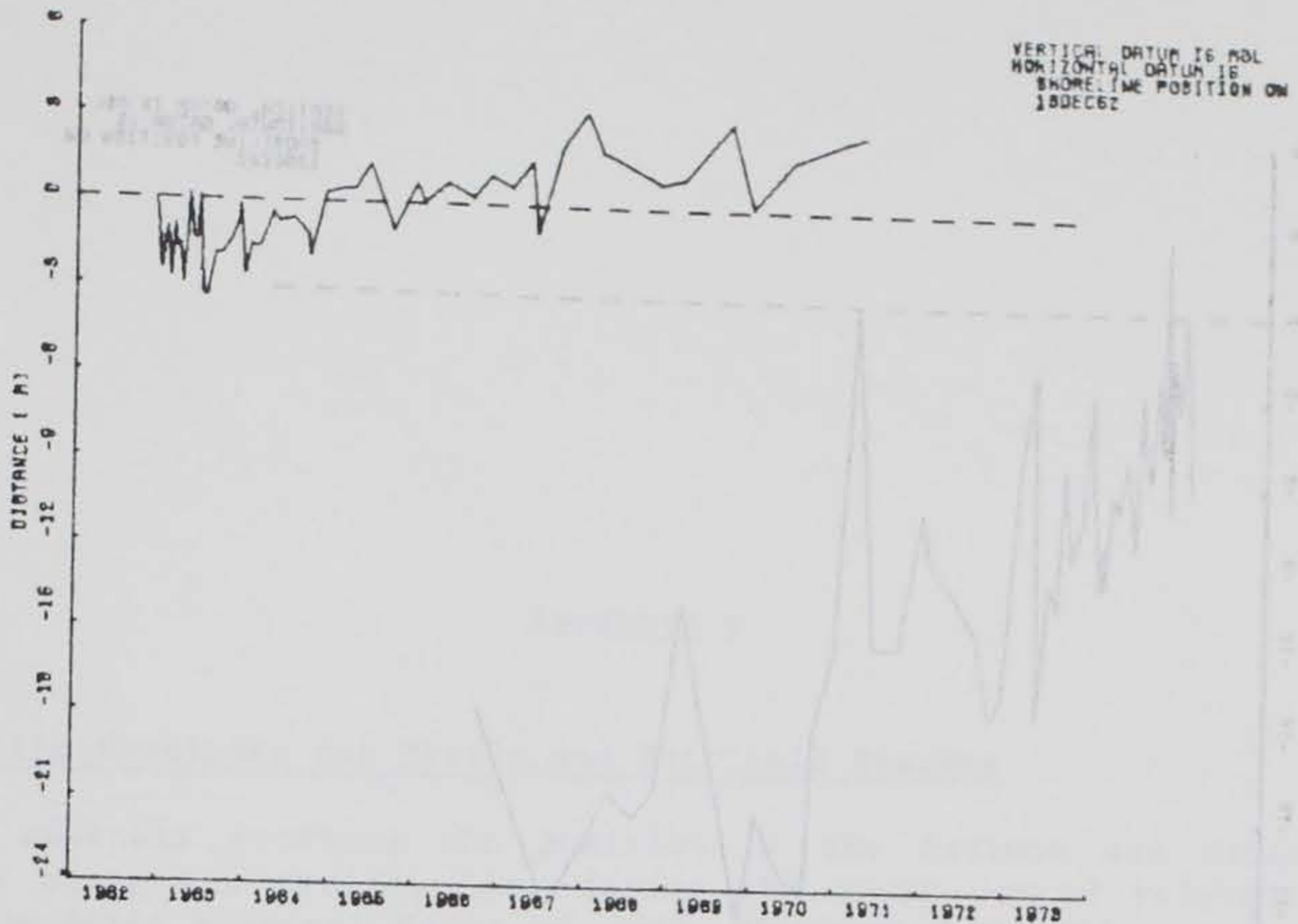

CHANGE IN DISTANCE TO SHORELINE AT  
PROFILE LINE 1 FAIRFIELD BEACH, CONNECTICUT

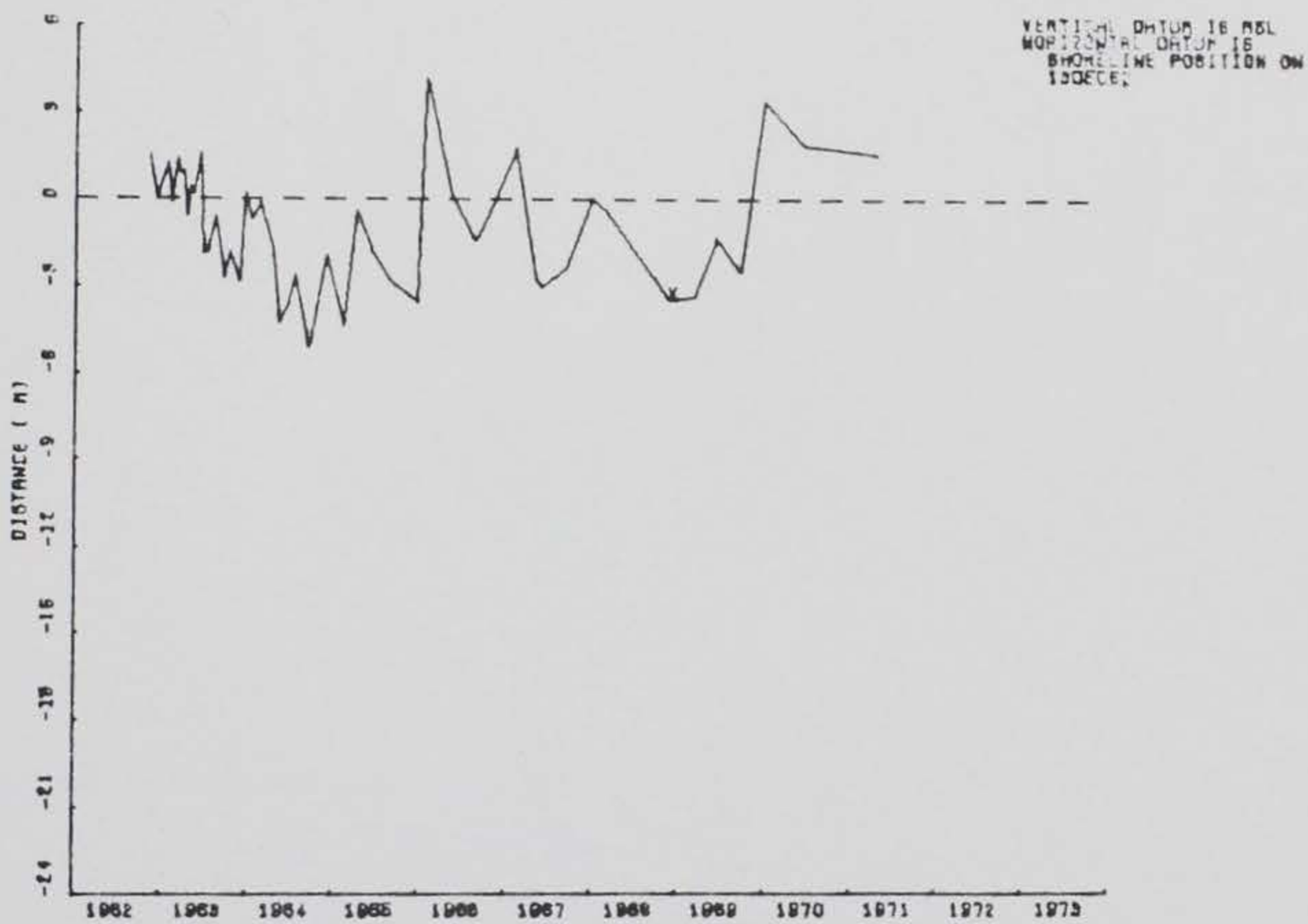

CHANGE IN DISTANCE TO SHORELINE AT  
PROFILE LINE 2 FAIRFIELD BEACH, CONNECTICUT

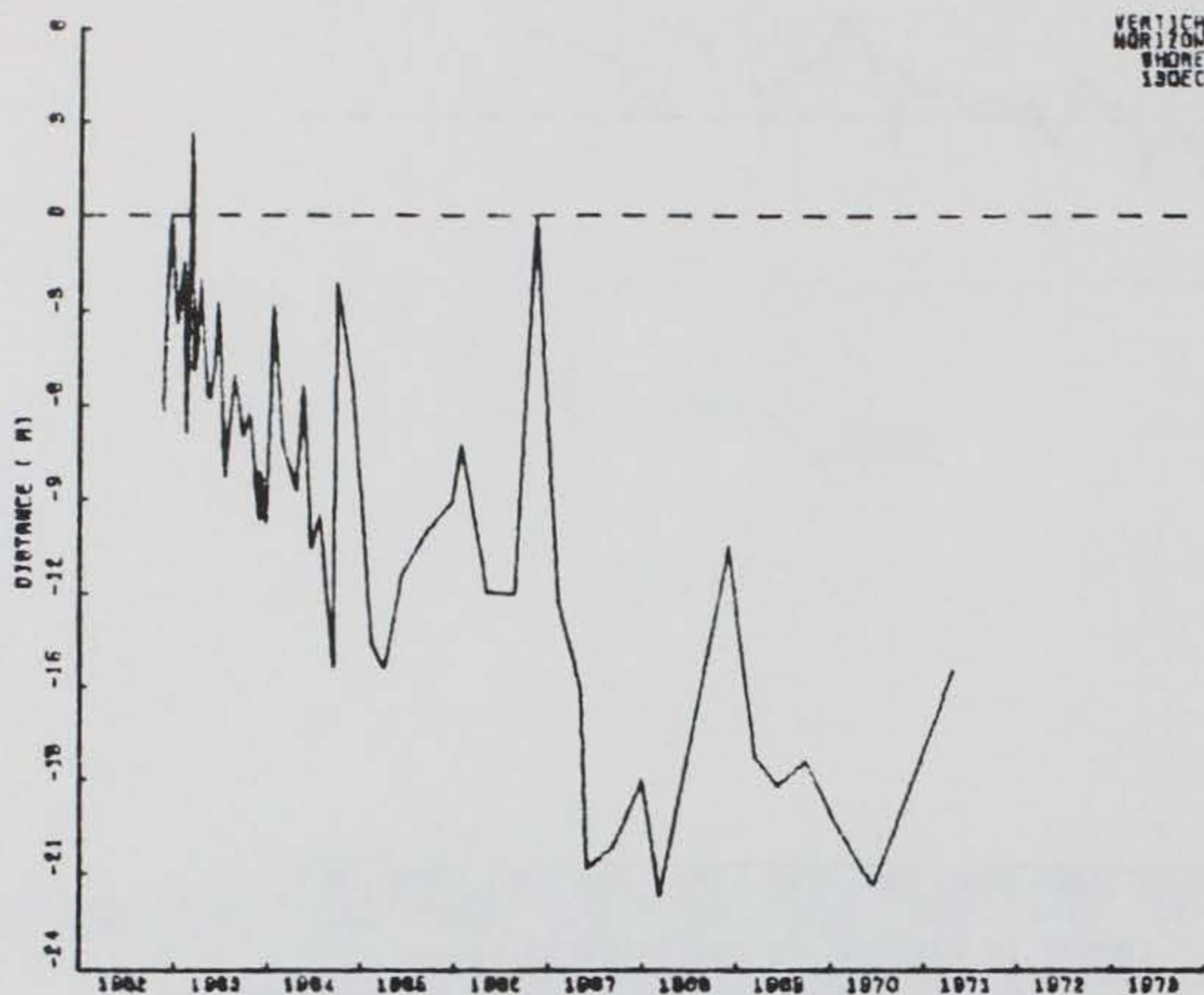

CHANGE IN DISTANCE TO SHORELINE AT  
PROFILE LINE 3 FAIRFIELD BEACH, CONNECTICUT

## APPENDIX F

### Beach Profile Envelopes for Myrtle and Fairfield Beaches

This appendix provides the position of the maximum and minimum sand elevations along the profile line during the study period relative to the National Geodetic Vertical Datum of 1929. Horizontal positions are measured from the MSL shoreline intercept on the first survey of the study for each profile line.

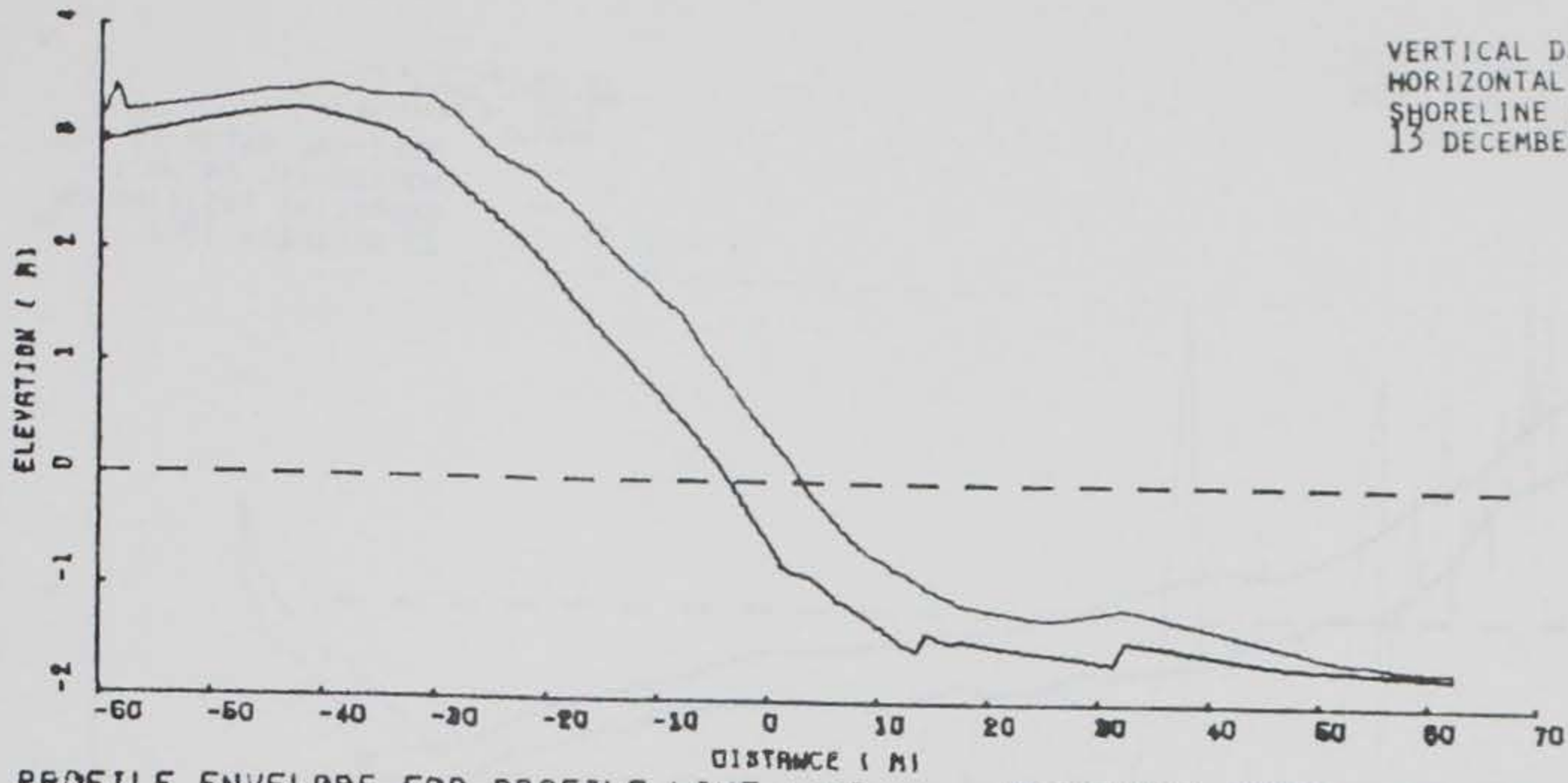

PROFILE ENVELOPE FOR PROFILE LINE 1 AT FAIRFIELD BEACH, CONNECTICUT  
13DEC62 - 20APR71

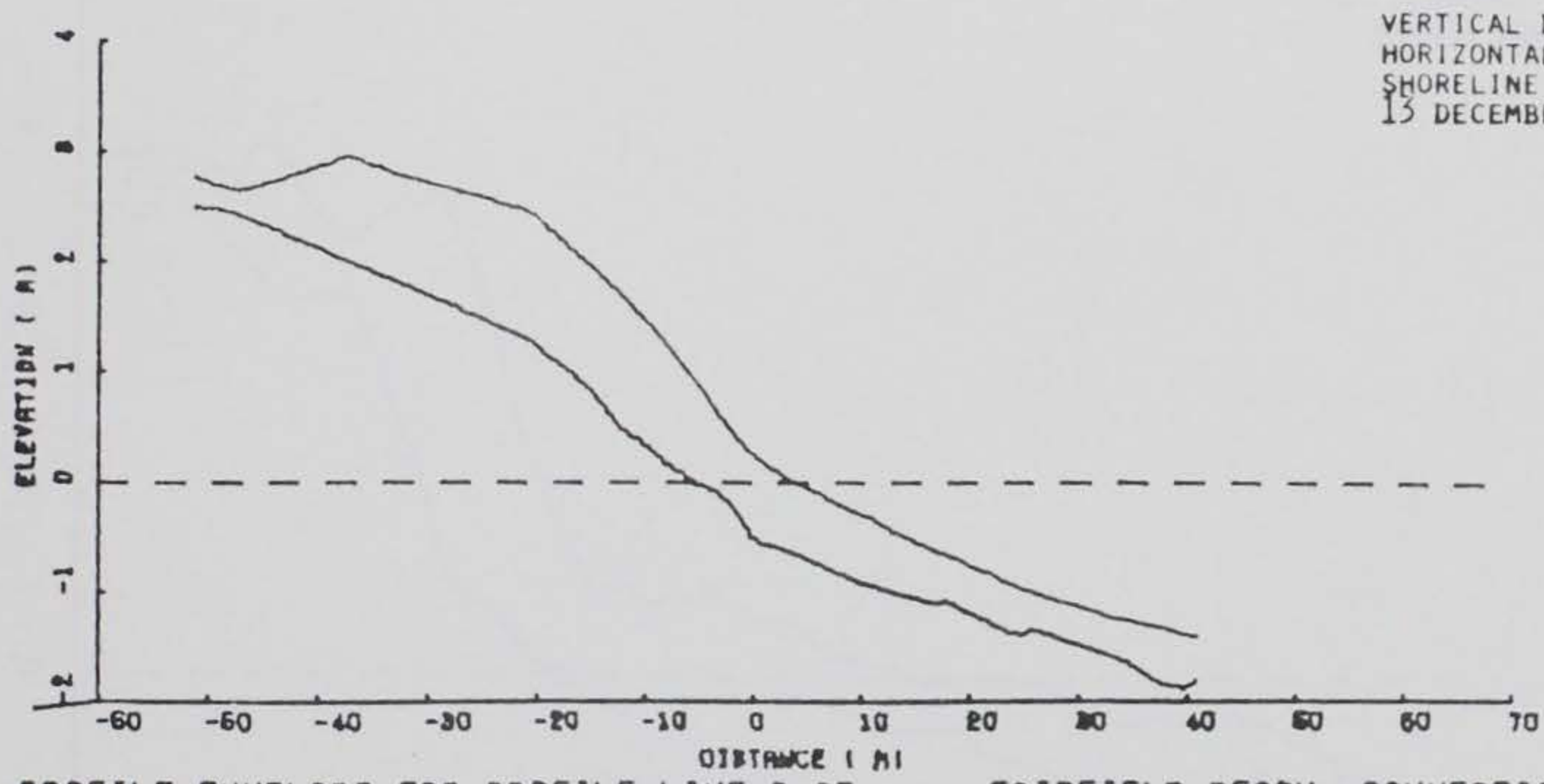

PROFILE ENVELOPE FOR PROFILE LINE 2 AT FAIRFIELD BEACH, CONNECTICUT  
13NOV62 - 20APR71

VERTICAL DATUM IS MSL  
HORIZONTAL DATUM IS  
SHORELINE POSITION ON  
15 DECEMBER 1962

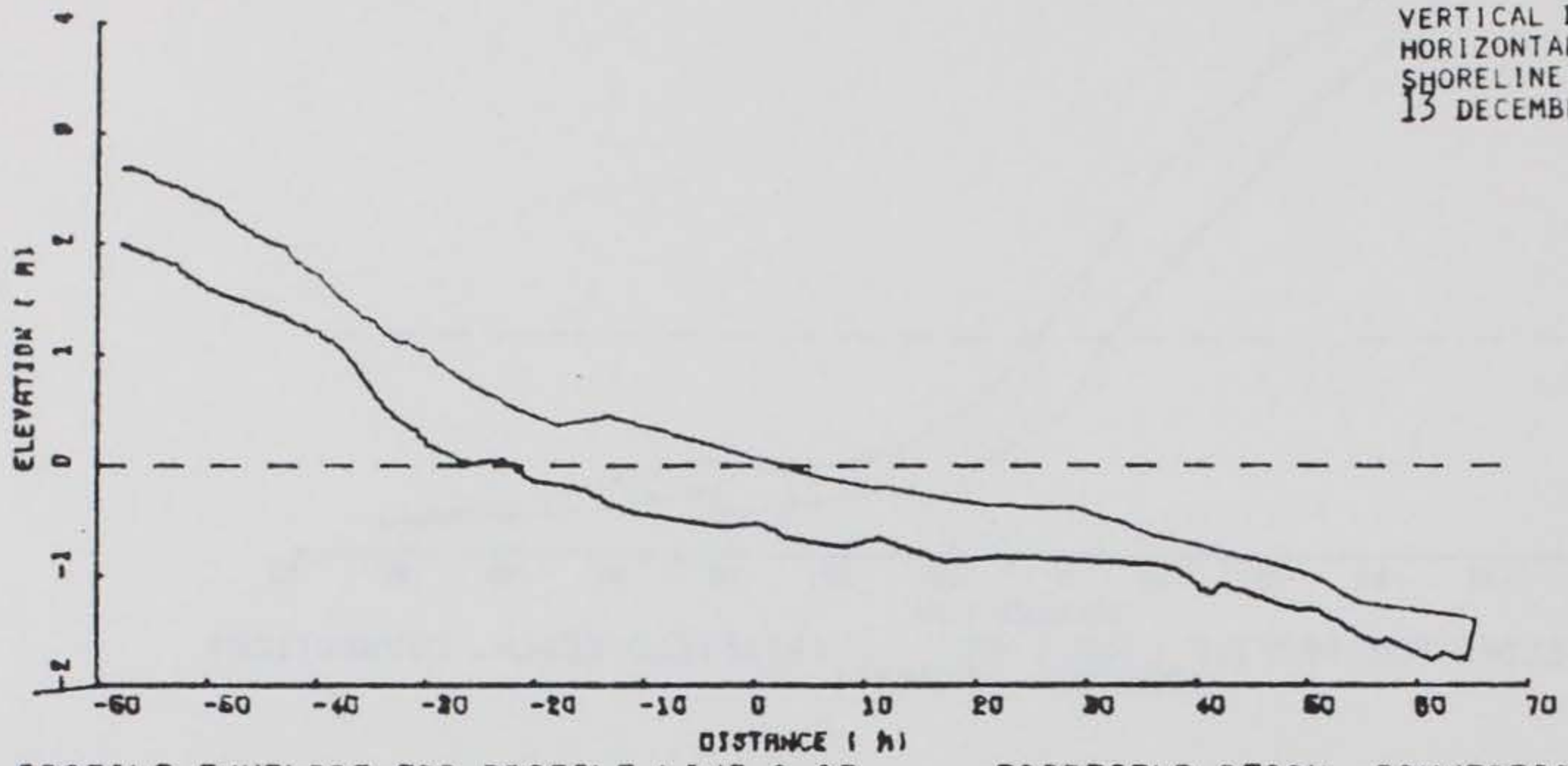

PROFILE ENVELOPE FOR PROFILE LINE 3 AT FAIRFIELD BEACH, CONNECTICUT  
13NOV62 - 20APR71

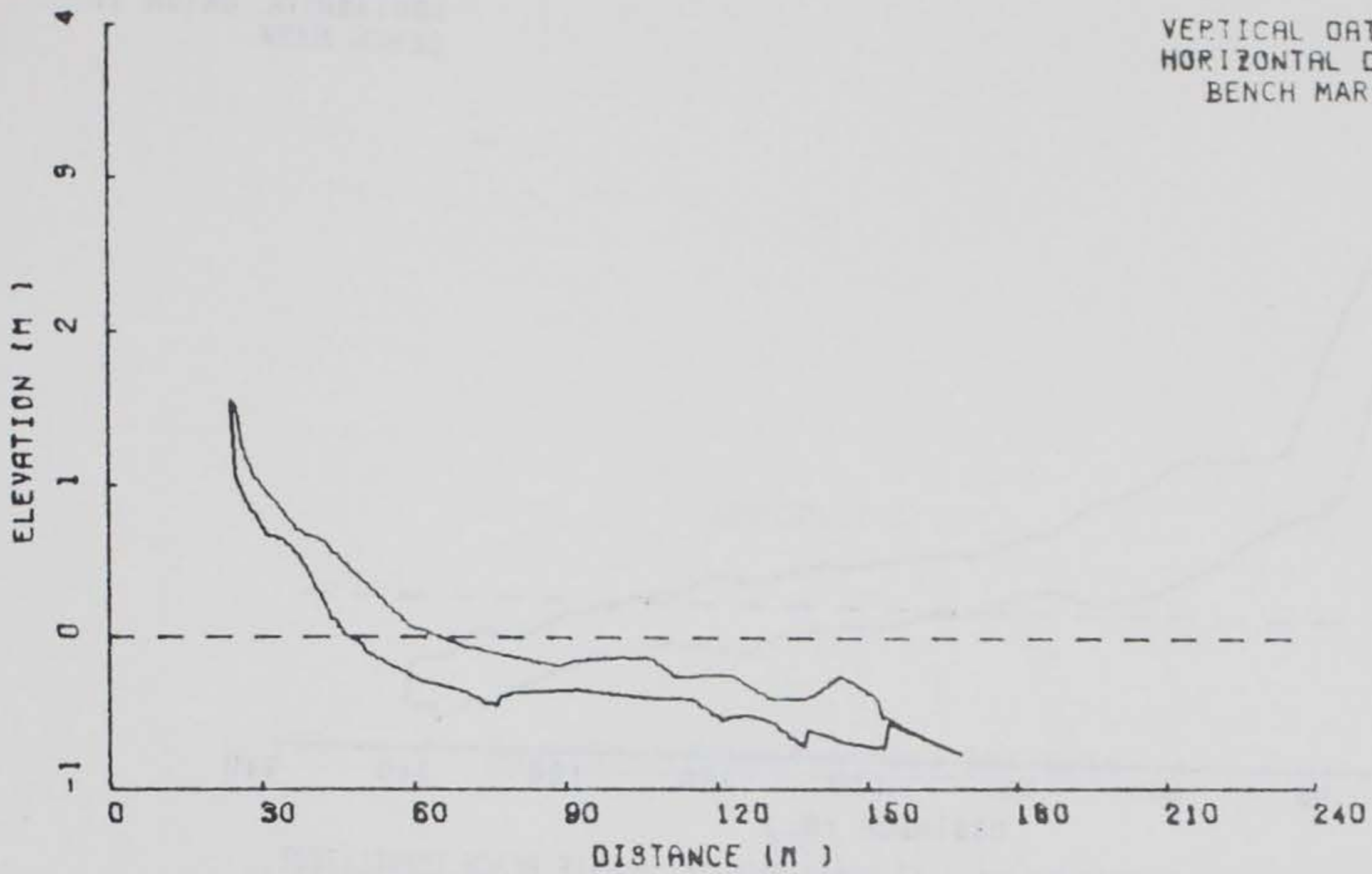

PROFILE ENVELOPE FOR PROFILE LINE 3 AT BEACH PROFILES MYRTLE BEACH, CONNECTICUT.  
20 DECEMBER 1965 - 16 JUNE 1970

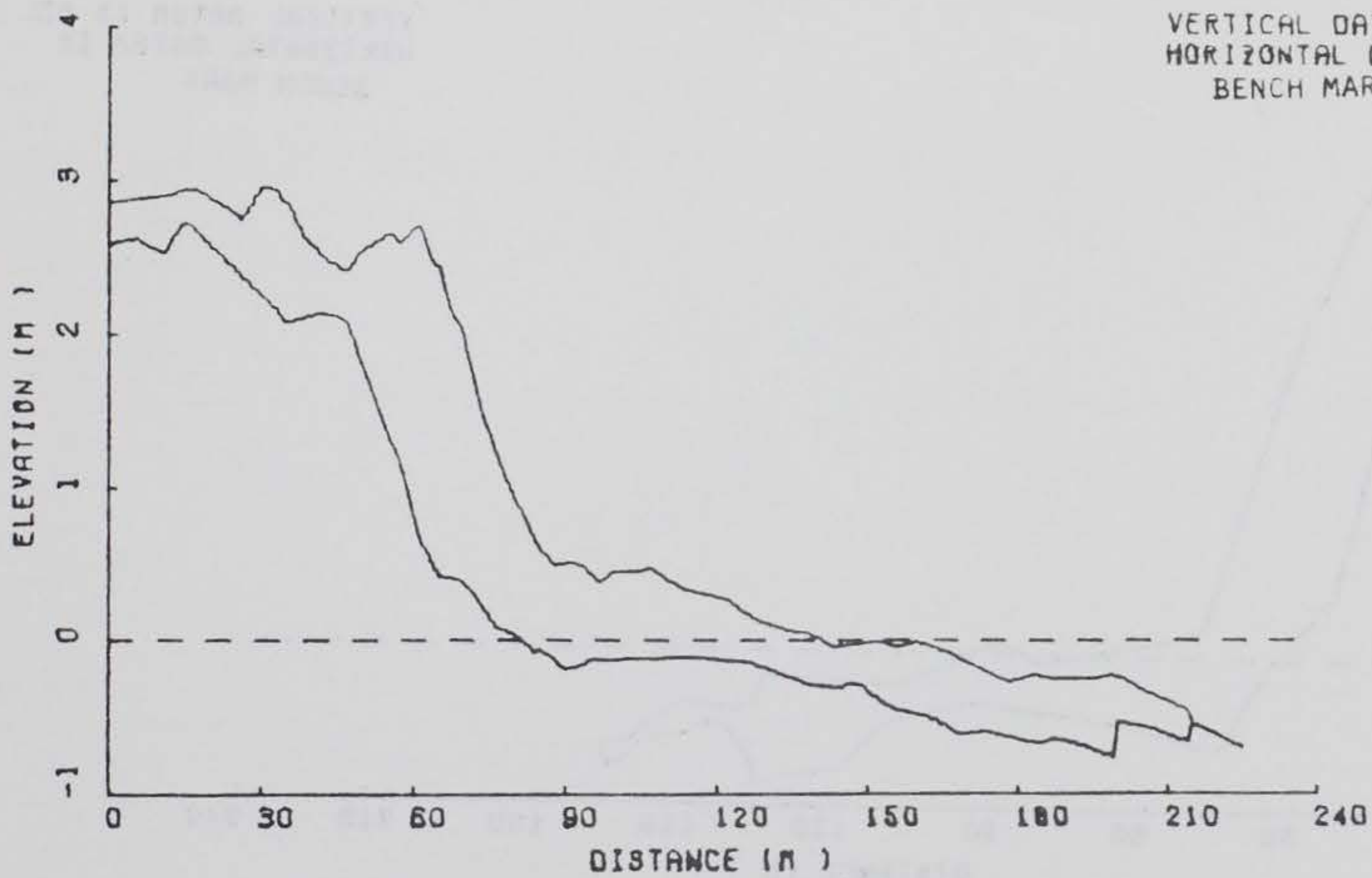

PROFILE ENVELOPE FOR PROFILE LINE 4 AT BEACH PROFILES MYRTLE BEACH, CONNECTICUT.  
9 NOVEMBER 1962 - 19 APRIL 1971



VERTICAL DATUM IS MSL  
HORIZONTAL DATUM IS  
BENCH MARK

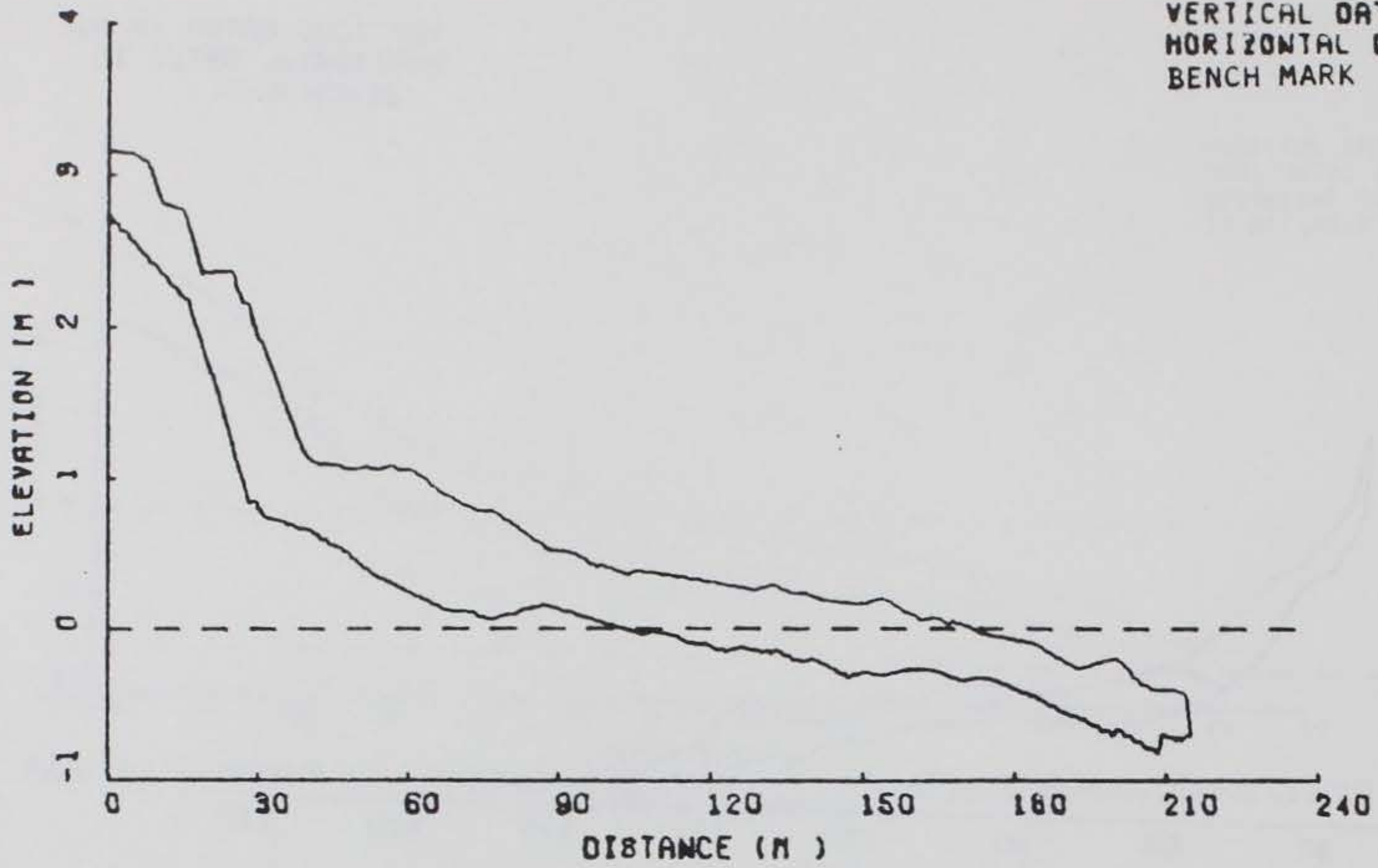

PROFILE ENVELOPE FOR PROFILE LINE 1 AT BEACH PROFILES MYRTLE BEACH, CONNECTICUT.  
9 NOVEMBER 1962 - 19 APRIL 1971

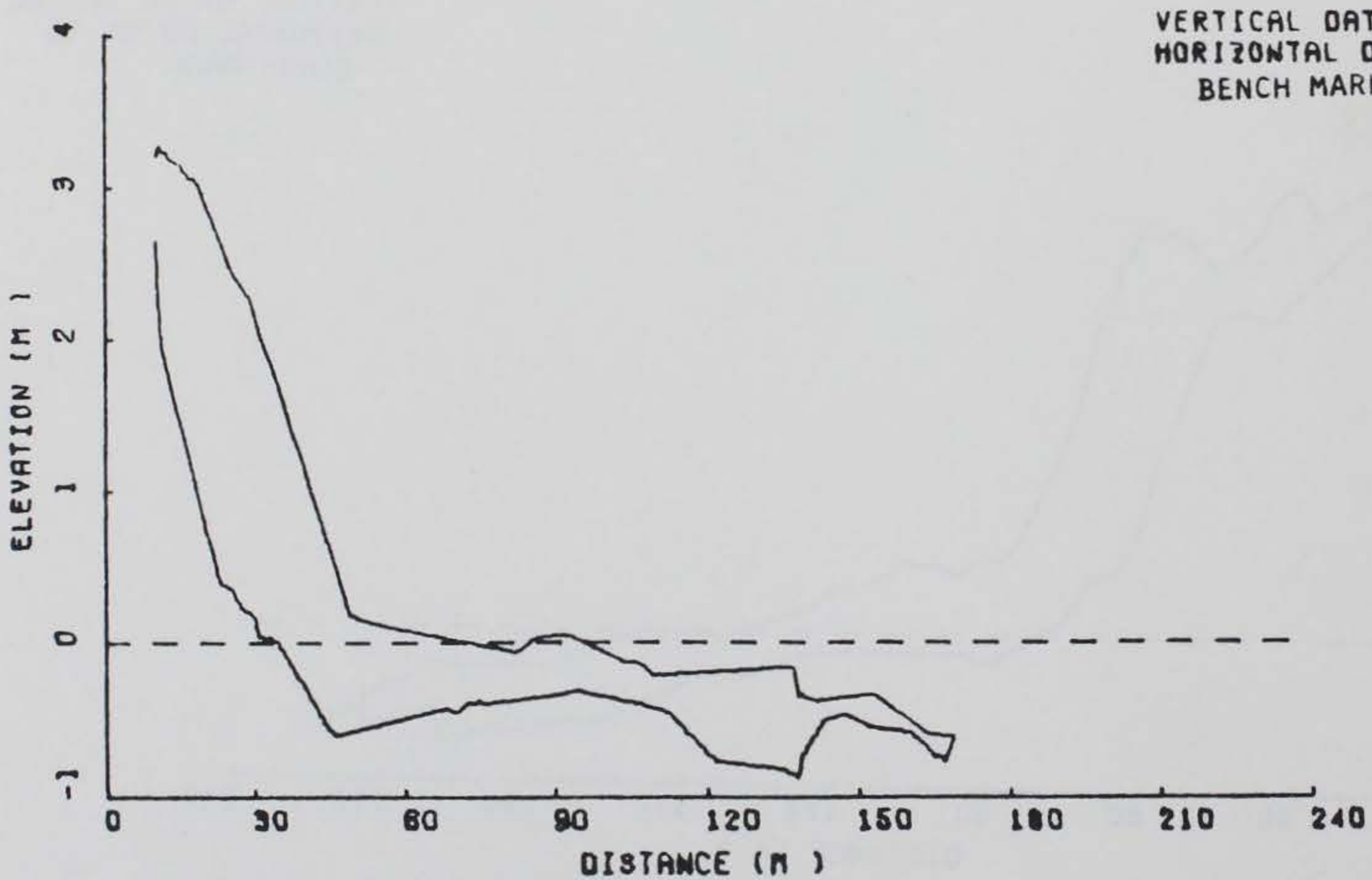

PROFILE ENVELOPE FOR PROFILE LINE 2 AT BEACH PROFILES MYRTLE BEACH, CONNECTICUT.  
9 NOVEMBER 1962 - 19 APRIL 1971

APPENDIX G

Empirical Eigenfunction Analysis

with

Myrtle and Fairfield Beach Eigenfunctions

## EMPIRICAL EIGENFUNCTION ANALYSIS

1. Methodology.

The empirical eigenfunction technique has been used by other investigators to determine the modes of variability of periodic beach profile measurements. The method can be useful in showing the spatial location at which the major amount of beach variability occurs along the profile line. Temporal eigenfunctions also show seasonal or other period trends in the data that may be less obvious by other methods of analysis. Properly used in conjunction with other, more conventional methods of analysis, the empirical eigenfunction technique provides a useful tool for understanding beach variability. Noble and Daniel (1977) provide a general explanation of the techniques. Specific applications to the coastal zone and beaches are provided by Winant, Inman, and Nordstrom (1975); Vincent, et al. (1976); Resio, et al. (1977); Aubrey (1978, 1979); and Bowman (1981).

The objective of eigenfunction analysis is to separate the temporal and spatial dependence of the data set so that it can be represented as a linear combination of corresponding functions of time and space:

$$h(x,t) = \sum_{\ell=1}^n c_{\ell}(t) e_{\ell}(x) (\lambda_{\ell} n_x n_t)^{1/2} \quad (1)$$

where

$h(x,t)$  = a profile sample at any point  $x$  and time  $t$

$n$  = the lesser of  $n_x$  and  $n_t$  (the number of points along each profile line and the number of times the profile was measured, respectively)

$c_{\ell}(t)$  = temporal beach eigenfunctions

$e_{\ell}(x)$  = spatial beach eigenfunctions (BEF)

$\lambda_{\ell}$  = eigenvalues associated with each eigenfunction pair  $(c_{\ell}, e_{\ell})$ .

This representation helps identify processes responsible for profile changes, assists in evaluation of their relative importance, and aids the identification of specific events. The following properties of the empirical eigenfunction make it a desirable tool for analysis of beach profile data (Aubrey, 1978):

(1) Empirical eigenfunctions provide the most efficient method of compressing the data; i.e., the most dense representation of a data set in the same sense that the first  $n$  terms in the expansion represent more of the data variability than the first  $n$  terms of any other orthogonal expansion.

(2) Since both the spatial and temporal eigenfunctions are orthogonal sets, each corresponding set  $(\lambda_\ell, e_\ell(x), c_\ell(t))$  may be regarded as representing a mode of variability that is uncorrelated with any other mode.

(3) The eigenfunction representation is convenient when using the method of minimum mean square error estimation. The eigenfunctions provide a useful a priori method for reducing the number of variables in this estimation theory, and also provide a means of removing the noise (or less predictable part of the data) from the data set.

The empirical eigenfunctions objectively represent the variation in the beach profile configuration in terms of the distance from fixed data points and in terms of temporal changes in the profile over the period of the study. Comparison of the variability of eigenfunctions from a series of profiles taken along the beach may show differences due to the presence of structures or change in shoreline orientation.

Since the empirical eigenfunctions form an orthogonal set, they are similar in some respects to the more familiar Fourier analysis. In Fourier analysis, a sinusoidal variation in the data set is assumed, and the best fits the data to a series of sines and cosines. This method assumes beforehand some given form for the orthogonal functions; in empirical eigenfunction analysis, the data themselves determine the form of orthogonal functions which are used in the analysis.

Applied to systematic measurements of beach elevation, the eigenfunction representation forms a concise means of representing beach profile variability. The eigenfunction modes can be used to distinguish between variability on different time scales. Though a large number of eigenvalues are determined, Aubrey (1978) found that more than 99.75 percent of the MSV of their data set could be accounted for by the three eigenfunctions associated with the three largest eigenvalues. The second through fourth eigenvalues accounted for approximately 90 percent of the variability in 4-year data sets of beach profiles in southern California. This concise representation of beach profile variability is desirable when trying to compare different locations, especially for data sets spanning long periods of time.

In the empirical eigenfunction technique, eigenvalues,  $\lambda_\ell$ , provide information on weights of the eigenfunctions. Each eigenvalue gives the MSV of the data (the variance, if the mean has been removed) accounted for by the eigenfunctions. This provides a convenient means for ranking eigenfunctions and assessing the importance of each. This also provides a convenient means of removing noise from the data, if it is assumed that a function accounting for only a small part of the MSV of the data is not an important variable in the data. Eigenfunctions whose eigenvalues are below a certain value can be neglected in cases where they are being used in an estimation problem.

The sum of the eigenvalues,  $\lambda_\ell$ , is equal to the MSV of the profile data:

$$MSV = \sum_{\ell=1}^n \lambda_\ell = \frac{1}{n_x n_t} \sum_t \sum_x \{h(x,t)\}^2 \quad (2)$$

This MSV is dominated by the mean shape of the beach, since those parts of the beach with the greatest absolute elevations are weighted most heavily. Beach variability can be evaluated by removing the arithmetic mean profile from the data set and calculating the variance of the profile data. The variance used in this study is defined:

$$\text{variance} = \frac{1}{n_x n_t} \sum_t \sum_x (h(x,t) - h(x))^2 \quad (3)$$

where the  $h$  represents the arithmetic mean profile. Both mean beach eigenfunctions (BEF) and demeaned beach eigenfunctions are useful in this study. The mean eigenfunctions are calculated from the raw profile data directly; the demeaned BEF are calculated only after subtracting the mean (in time) profile from the profile data. The success or use of the beach eigenfunctions representation is judged by the percent of the MSV (for the case of mean BEF) or variance (for the demeaned BEF) accounted for by the first few eigenfunctions and eigenvalues.

Instead of removing the mean beach profile before the eigenfunction calculation, an alternative is to compute mean beach eigenfunctions, remove the MSV accounted for by the first eigenfunction, and look at the percent of the residual MSV accounted for by the remaining eigenfunctions. This procedure yields information analogous to the demeaning process, but gives slightly different results. The inclusion of the mean profile in the eigenfunction decomposition introduces variability in the profile not observed when the profiles are demeaned before the analysis (Aubrey, 1978). Both approaches have been used here.

An ultimate objective of beach profile analysis is to compare results from different localities to understand the effects of wave climate, continental slope width, wave sheltering, and weather patterns on beach variability. It is difficult to parameterize beach variability even using eigenfunction analysis, although the MSV and variance are obvious candidates for this purpose. The variance is sensitive to the length of the profile ( $n_x$ ). If the beach backshore is represented by 100 meters at one line and only 10 meters along another line, their variance could differ significantly, even though the beaches had comparable variabilities. A rough measure for comparison would be a modified variability, defined as:

$$\text{VAR}_m = R \text{ variability} \quad (4)$$

where  $R$  is the ratio of the total profile length to the length of the active beach. The length of the active beach can be taken as extending from the point of active winter erosion seawards to a practical limit of no motion. In the BEP profiles, since the measurements do not extend seaward to the limit of no motion, the seaward extent is the maximum offshore distance out to which the profiles were measured. An estimate of the onshore limit to the active beach can be the landwardmost point beyond which the second spatial eigenfunction is close to zero.  $R$  is constrained to have a maximum value of 1.

Although this criterion for beach profile change is ad hoc, it does yield a rough technique for intercomparing the mean variability of different beaches. The variability has a time average, but no spatial average, so it represents the variability over the entire beach. This measure would be useful for intercomparison, if taken to the same (or equivalent) offshore depth. Unless the first eigenfunction is removed, there is no equivalent measure for the MSV.

## 2. Whole Beach Eigenfunctions.

The following pages provide the graphic results of the spatial and temporal eigenfunction analysis for the total beach profiles. Only the first three eigenfunctions (mean retained) are provided. The next four pages represent the graphs from Milford while the last three pages of the appendix show the graphs for Fairfield.

SPATIAL EIGENFUNCTIONS  
 PROFILE LINE # 1 DATA NOT DemeanED

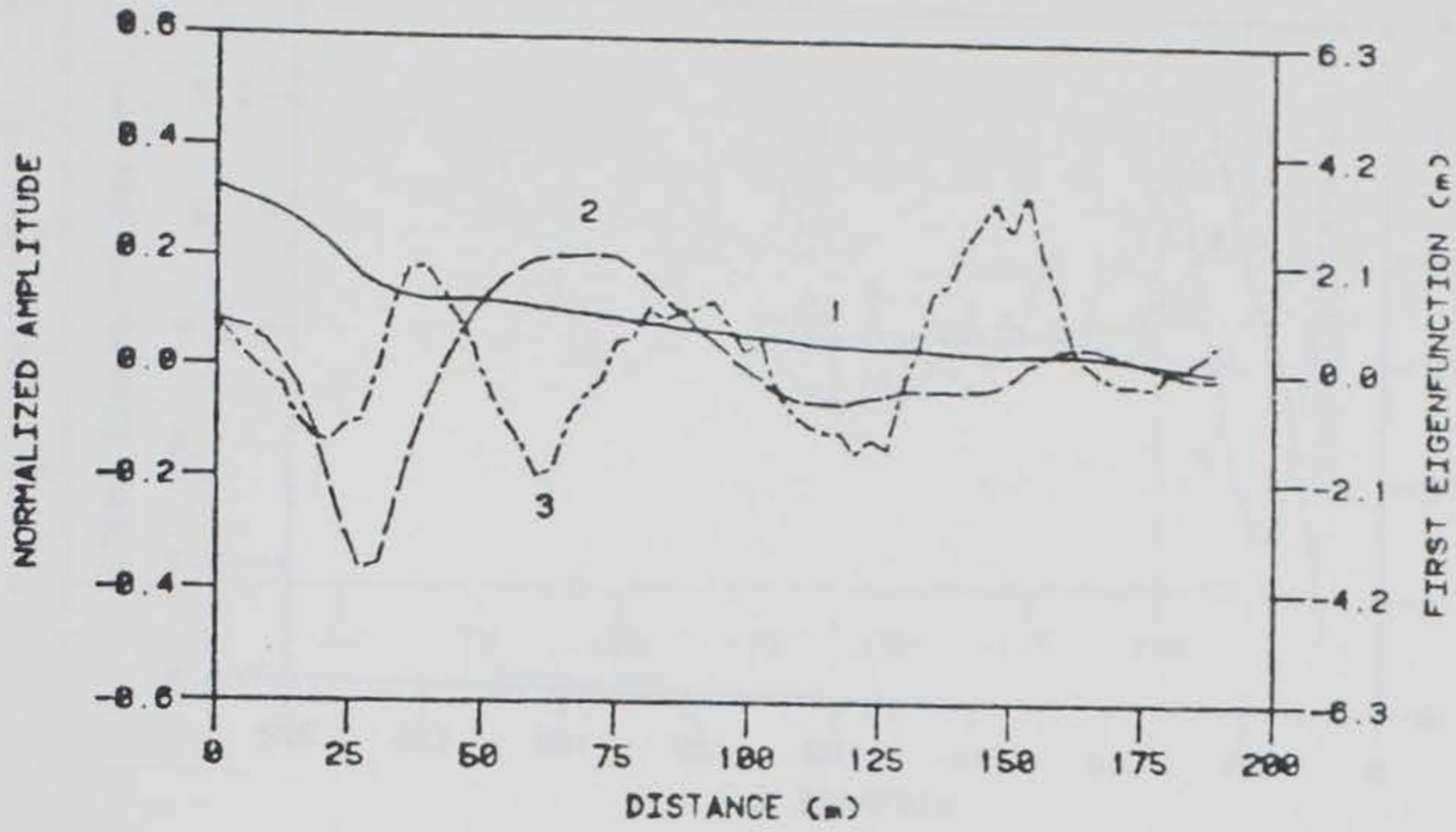

TEMPORAL EIGENFUNCTIONS  
 PROFILE LINE # 1 DATA NOT DemeanED

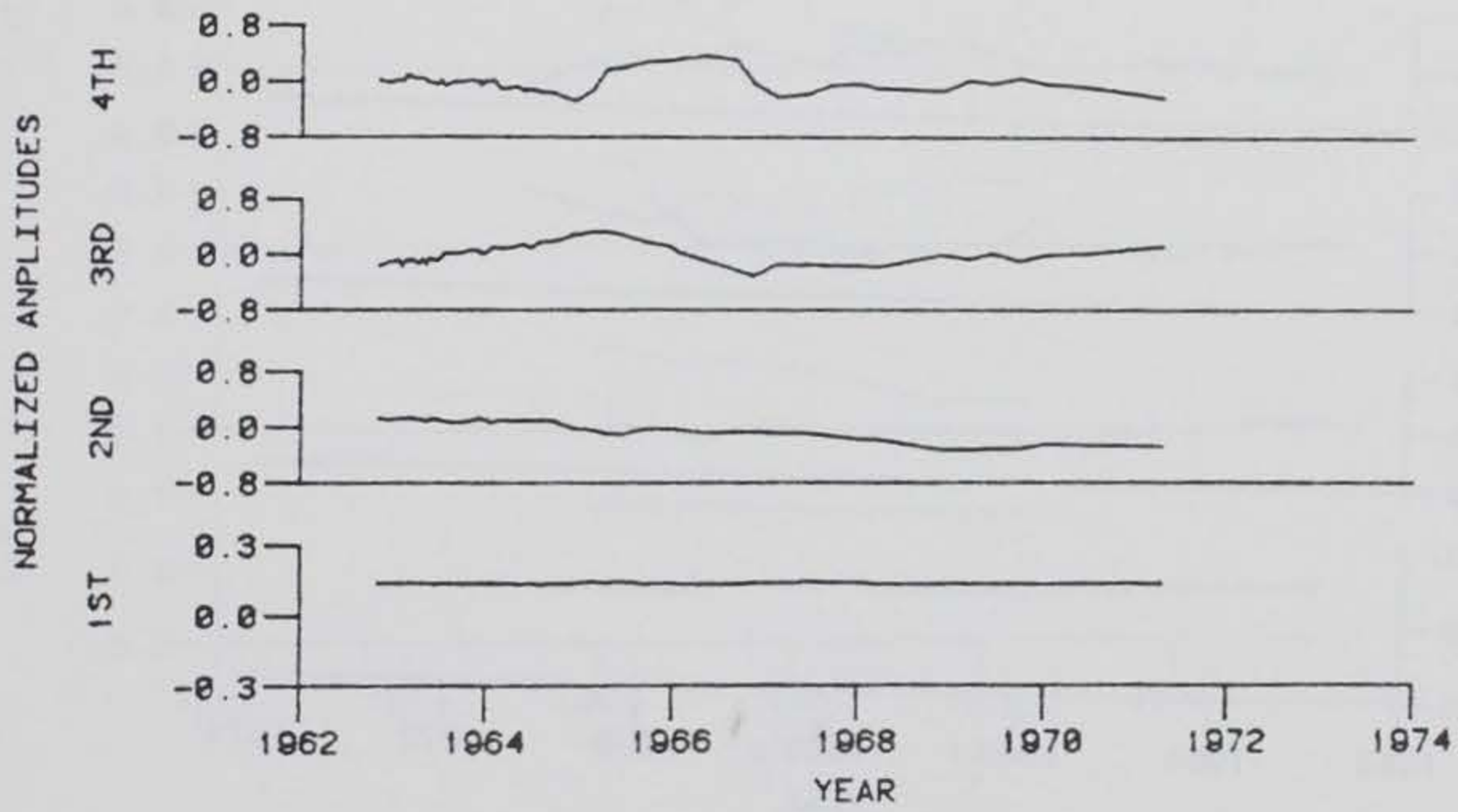

SPATIAL EIGENFUNCTIONS

PROFILE LINE 2 DATA NOT Demeaned

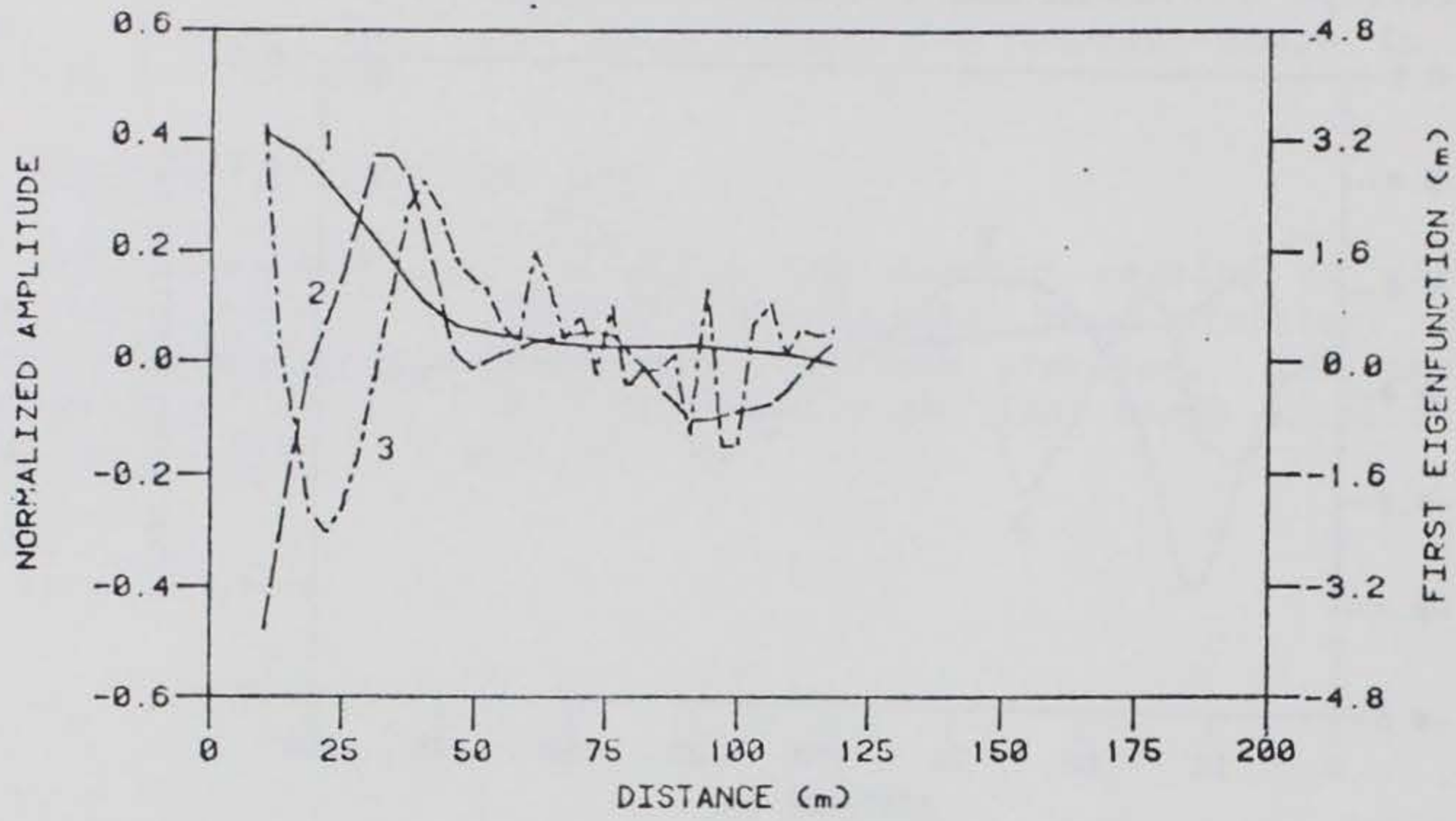

TEMPORAL EIGENFUNCTIONS

PROFILE LINE 2 DATA NOT Demeaned

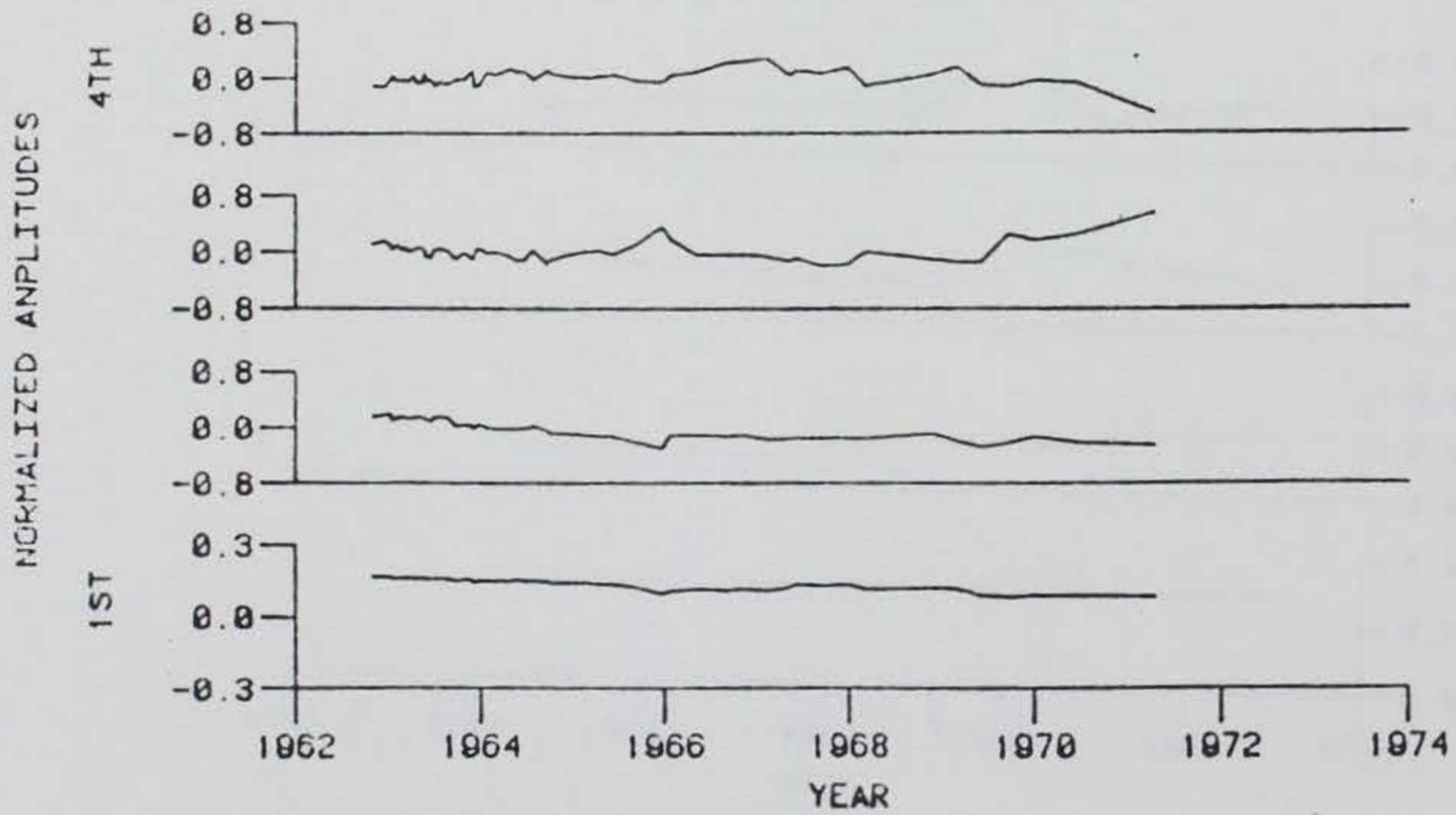



SPATIAL EIGENFUNCTIONS

PROFILE LINE 3 DATA NOT Demeaned

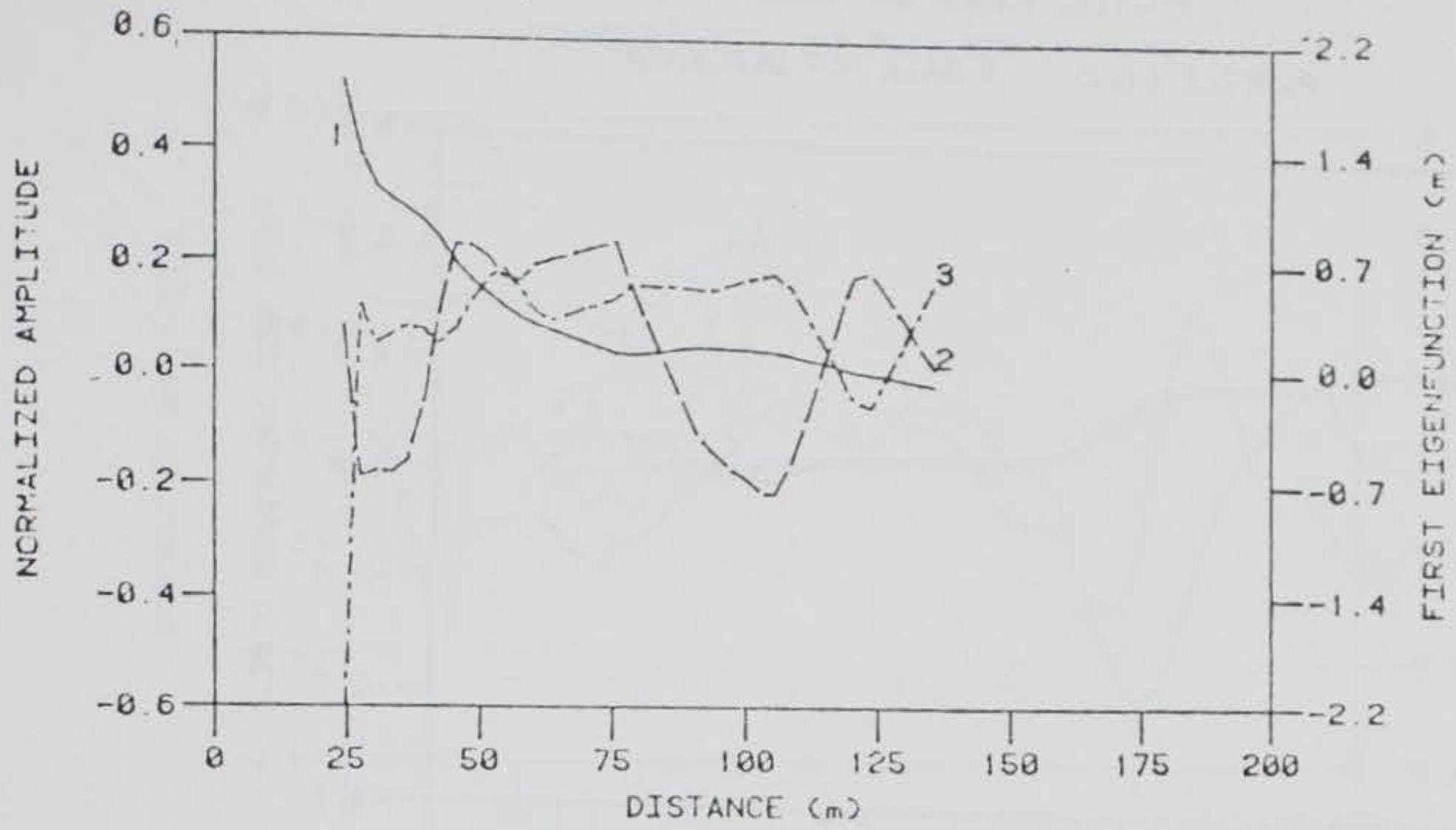

TEMPORAL EIGENFUNCTIONS

PROFILE LINE 3 DATA NOT Demeaned

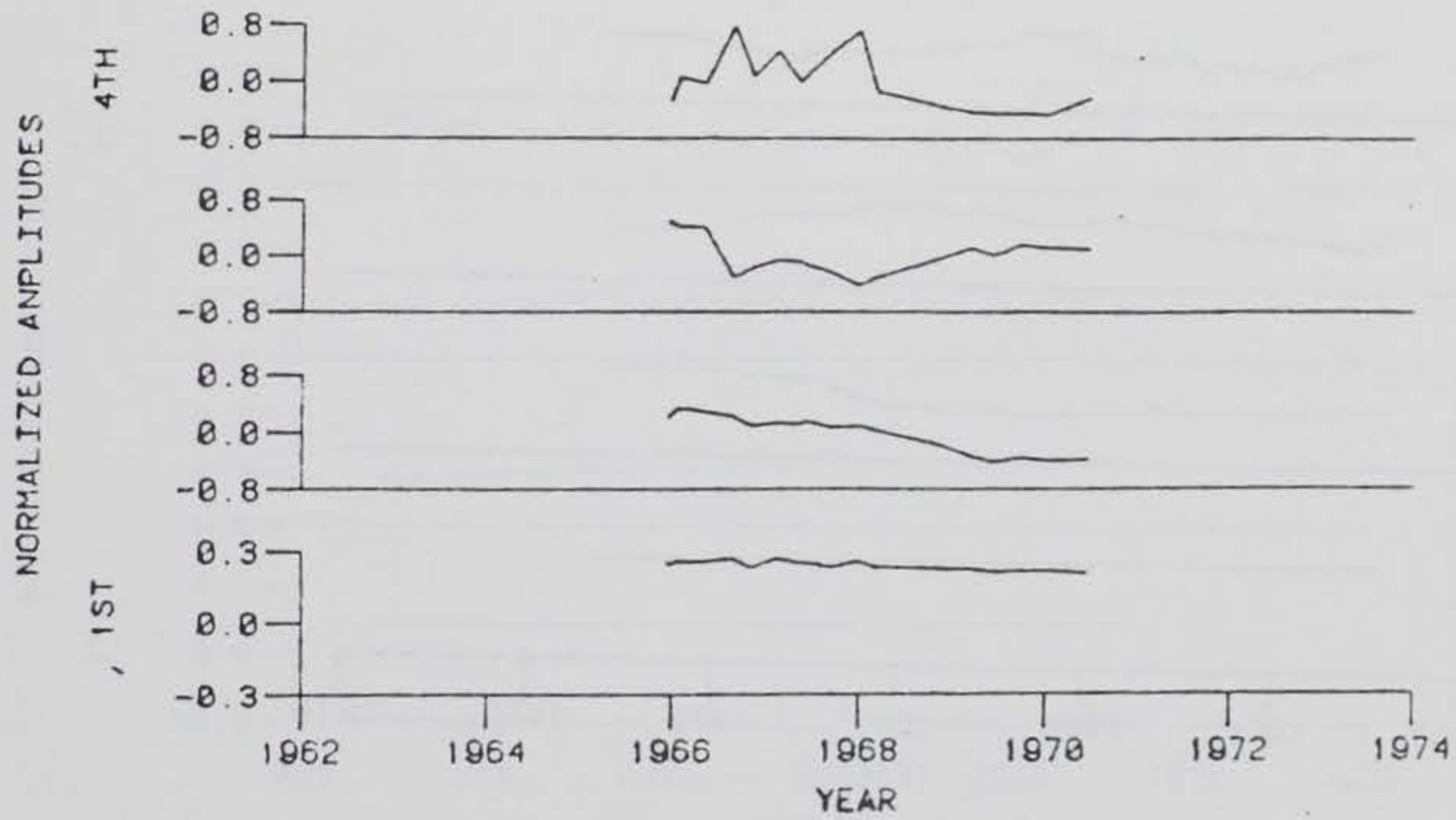

SPATIAL EIGENFUNCTIONS

PROFILE LINE 4 DATA NOT Demeaned

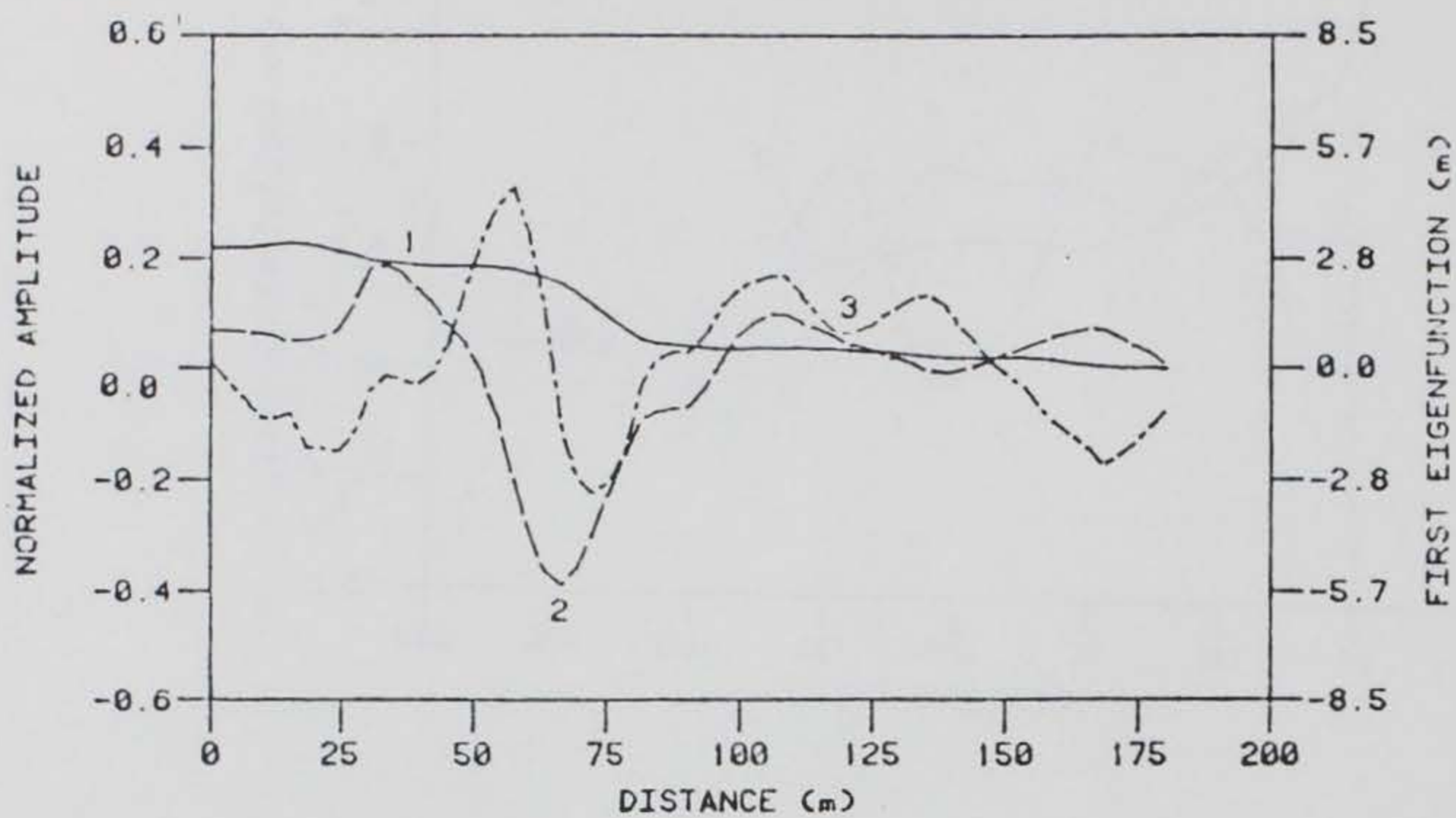

TEMPORAL EIGENFUNCTIONS

PROFILE LINE 4 DATA NOT Demeaned

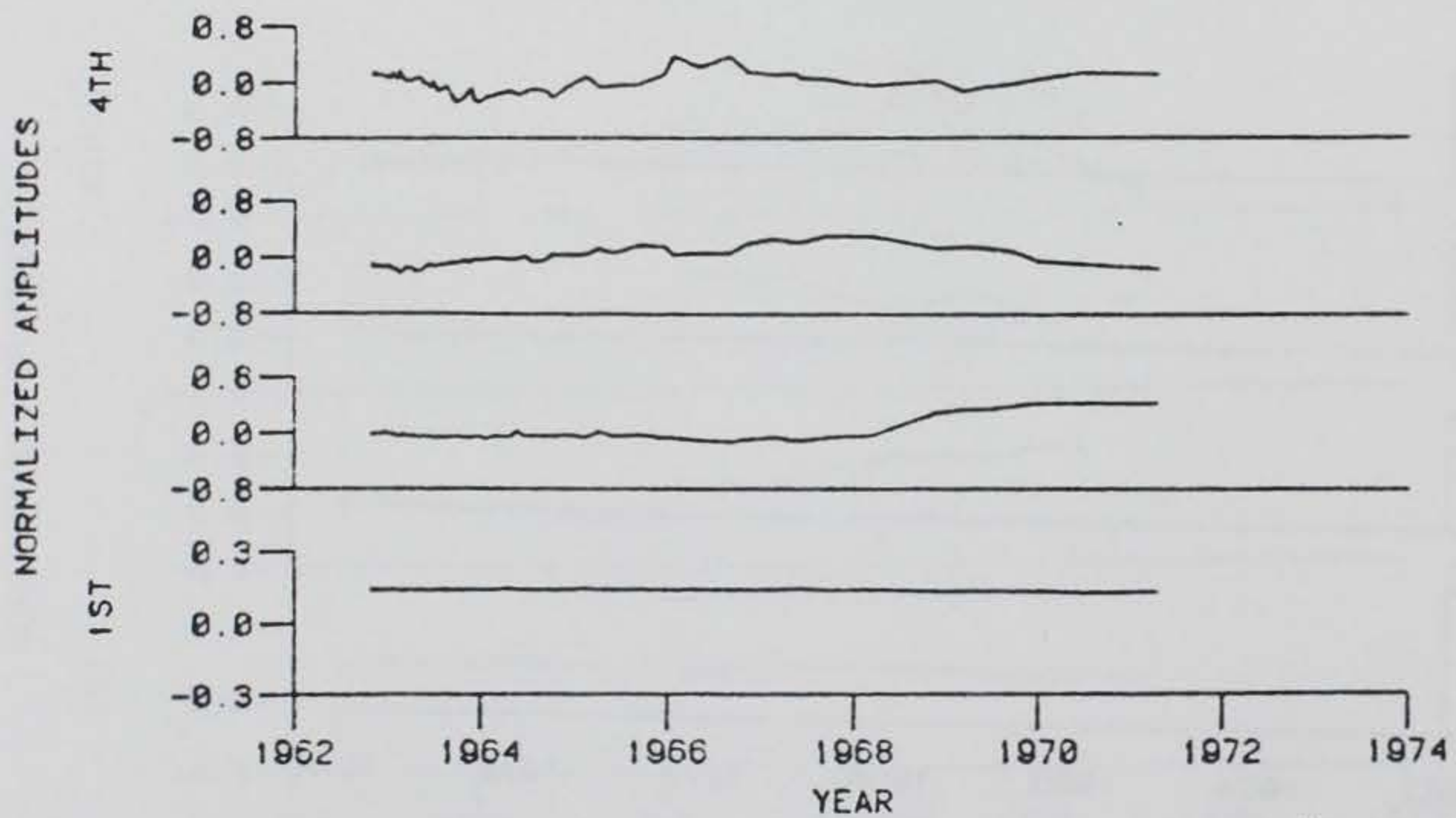

SPATIAL EIGENFUNCTIONS

PROFILE LINE 1 DATA NOT Demeaned

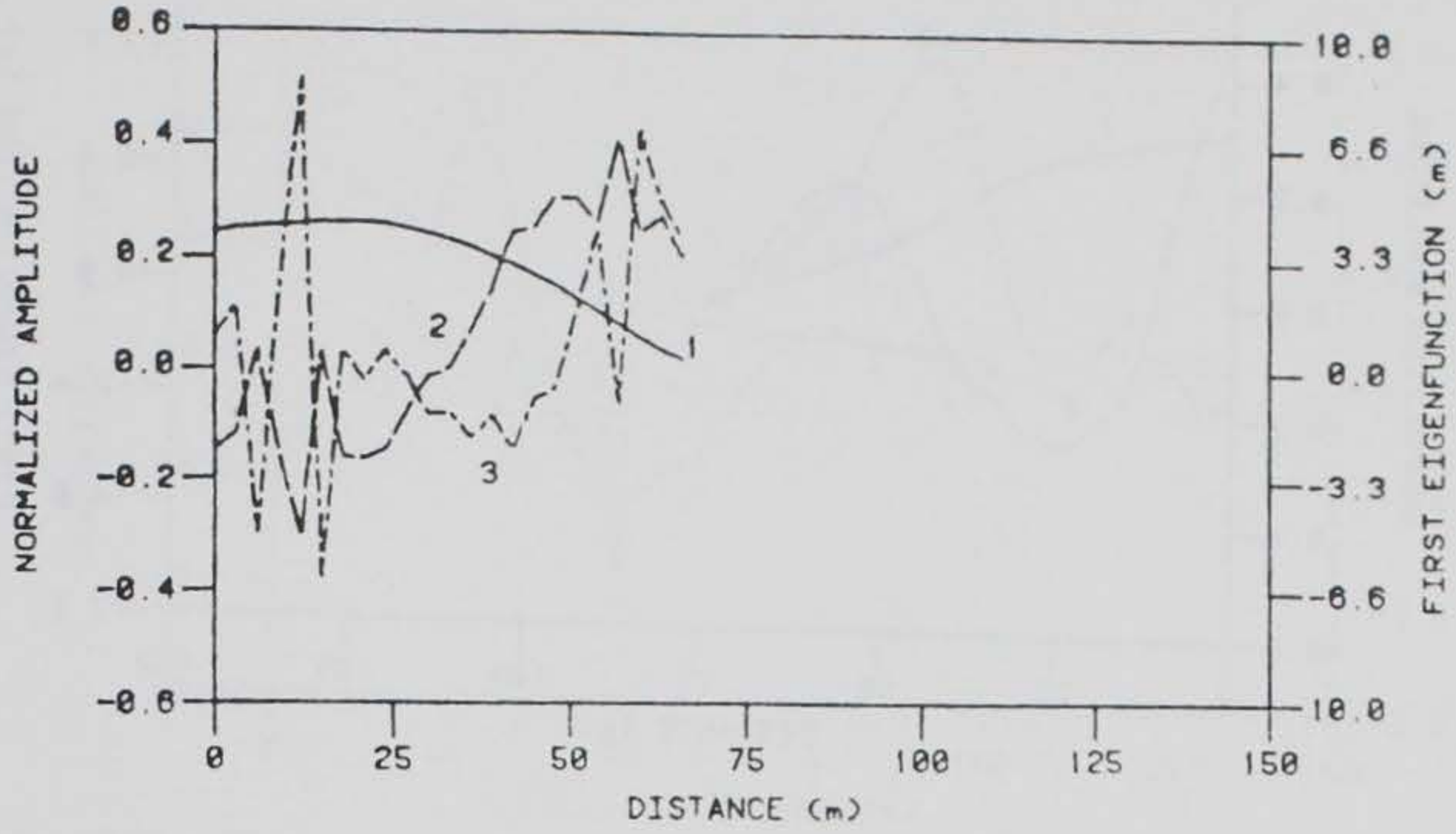

TEMPORAL EIGENFUNCTIONS

PROFILE LINE 1 DATA NOT Demeaned

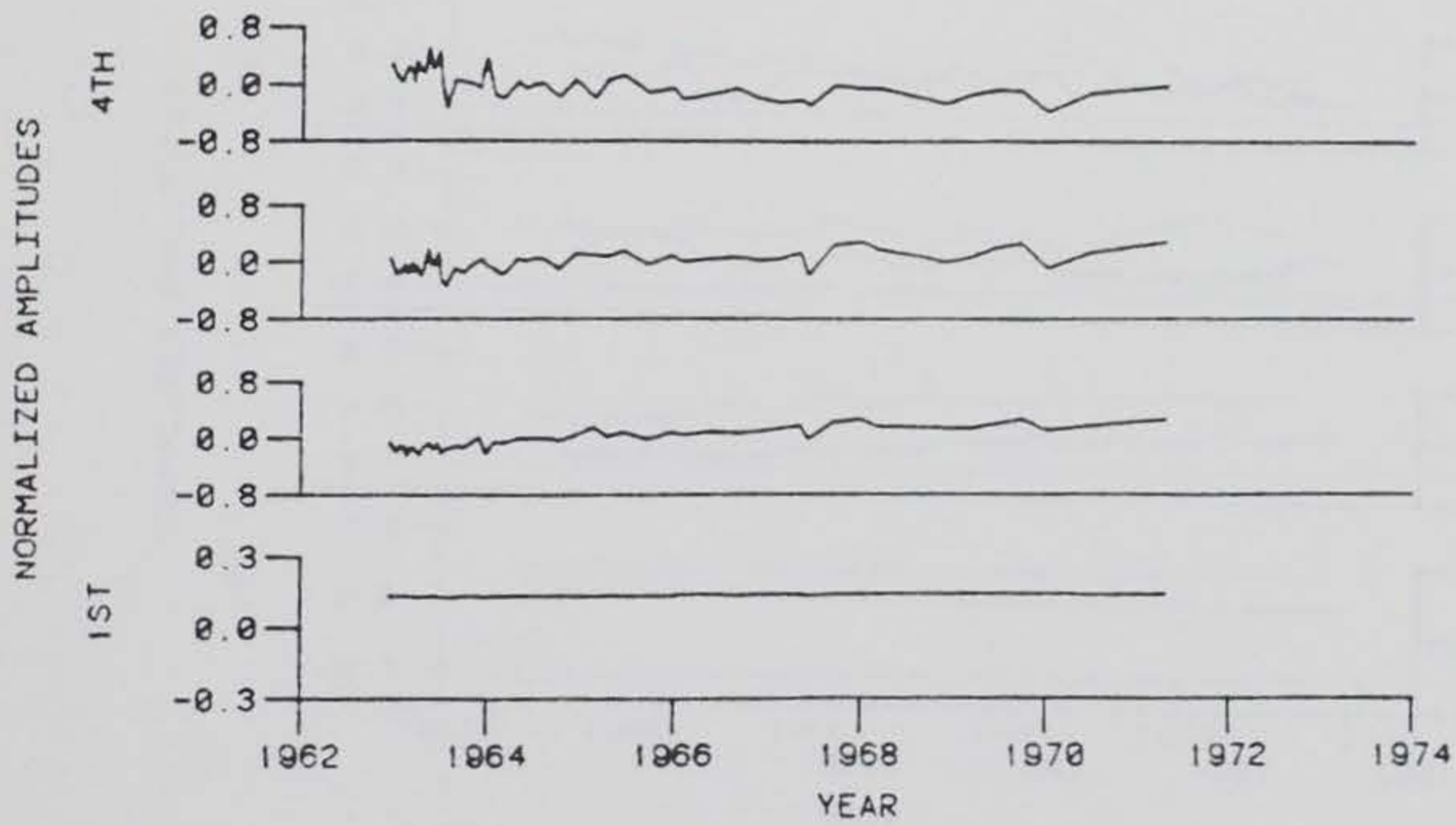

SPATIAL EIGENFUNCTIONS

PROFILE LINE 2 DATA NOT Demeaned

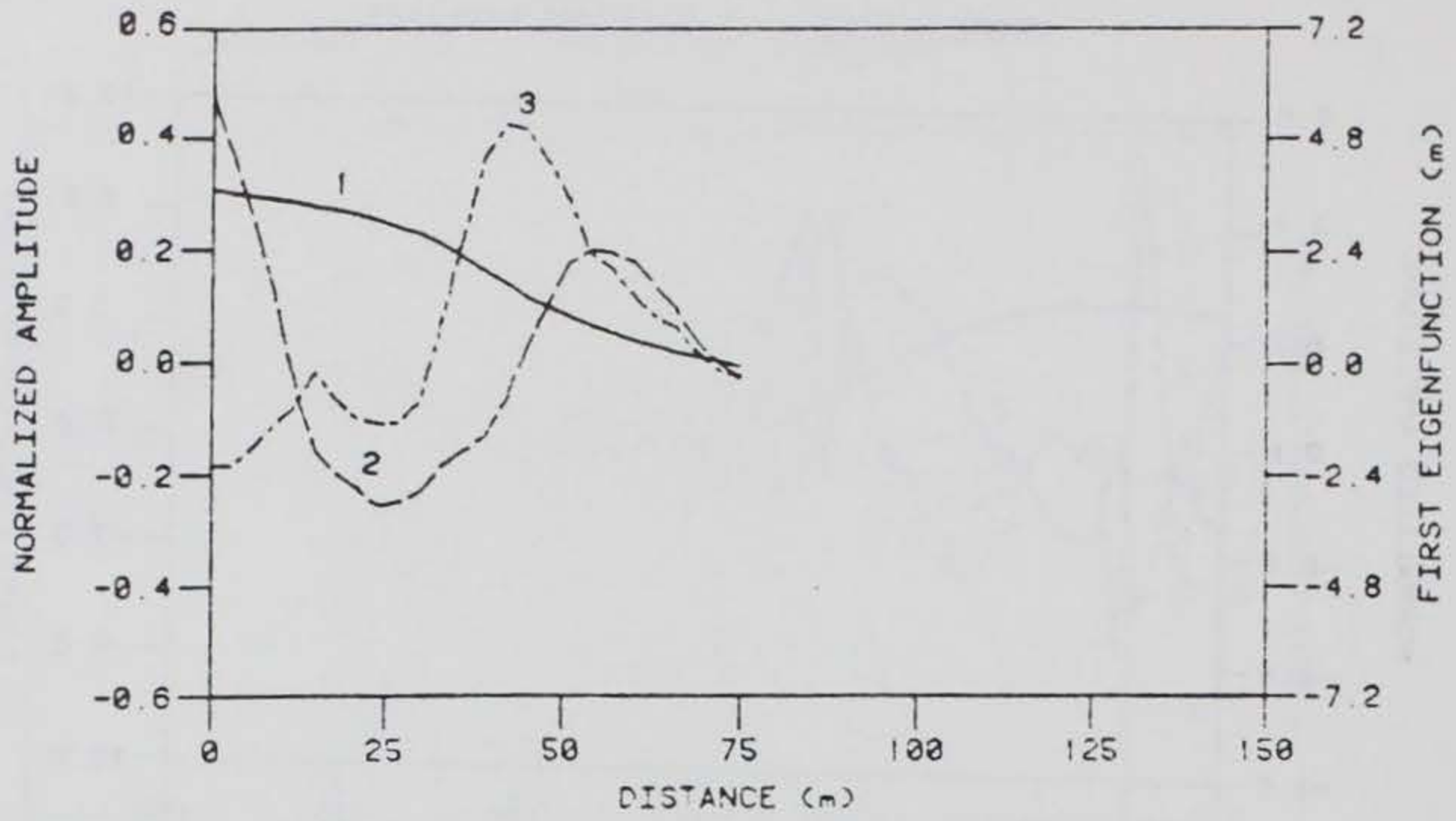

TEMPORAL EIGENFUNCTIONS

PROFILE LINE 2 DATA NOT Demeaned

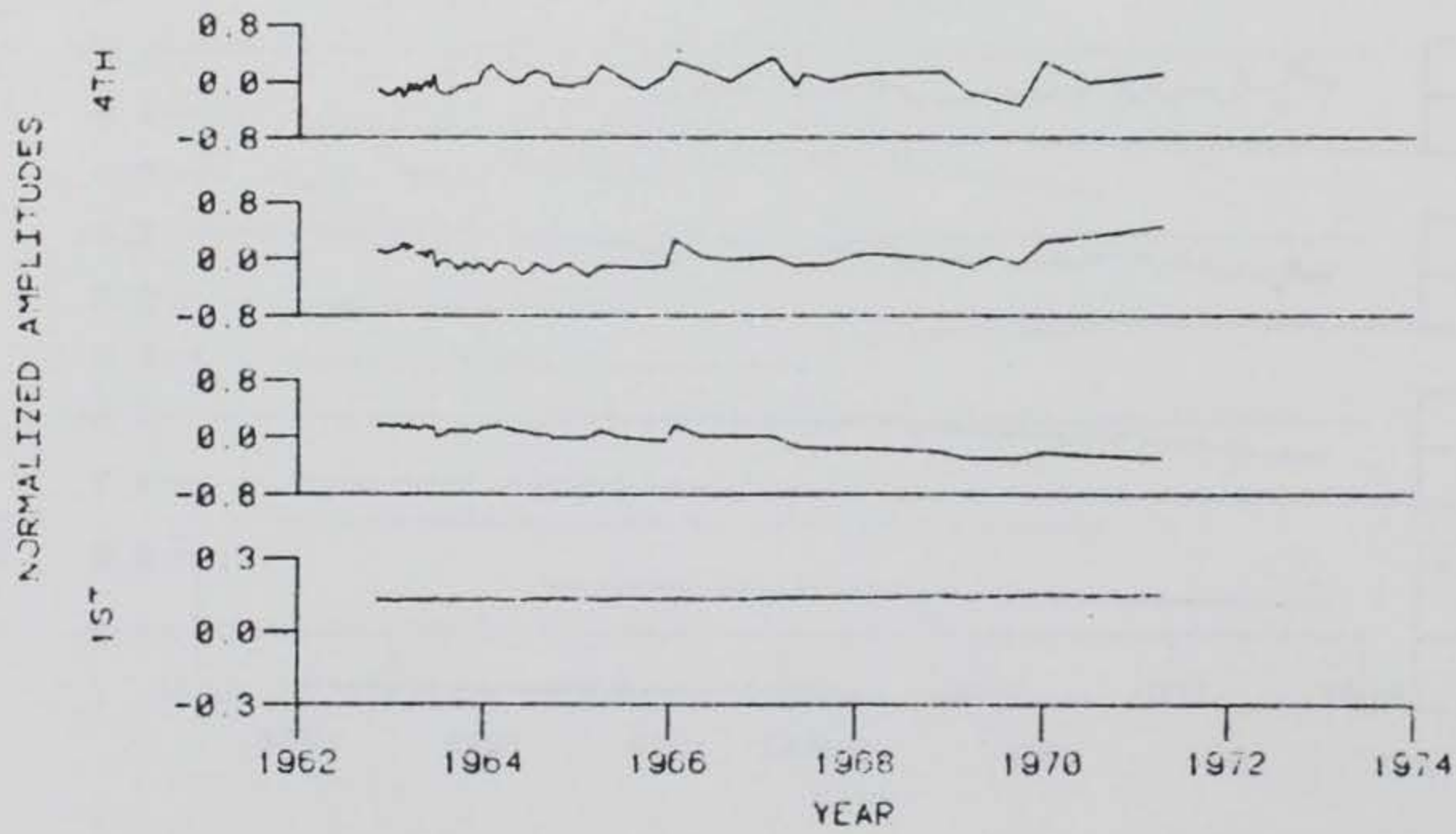

SPATIAL EIGENFUNCTIONS

PROFILE LINE 3 DATA NOT DEMAANED

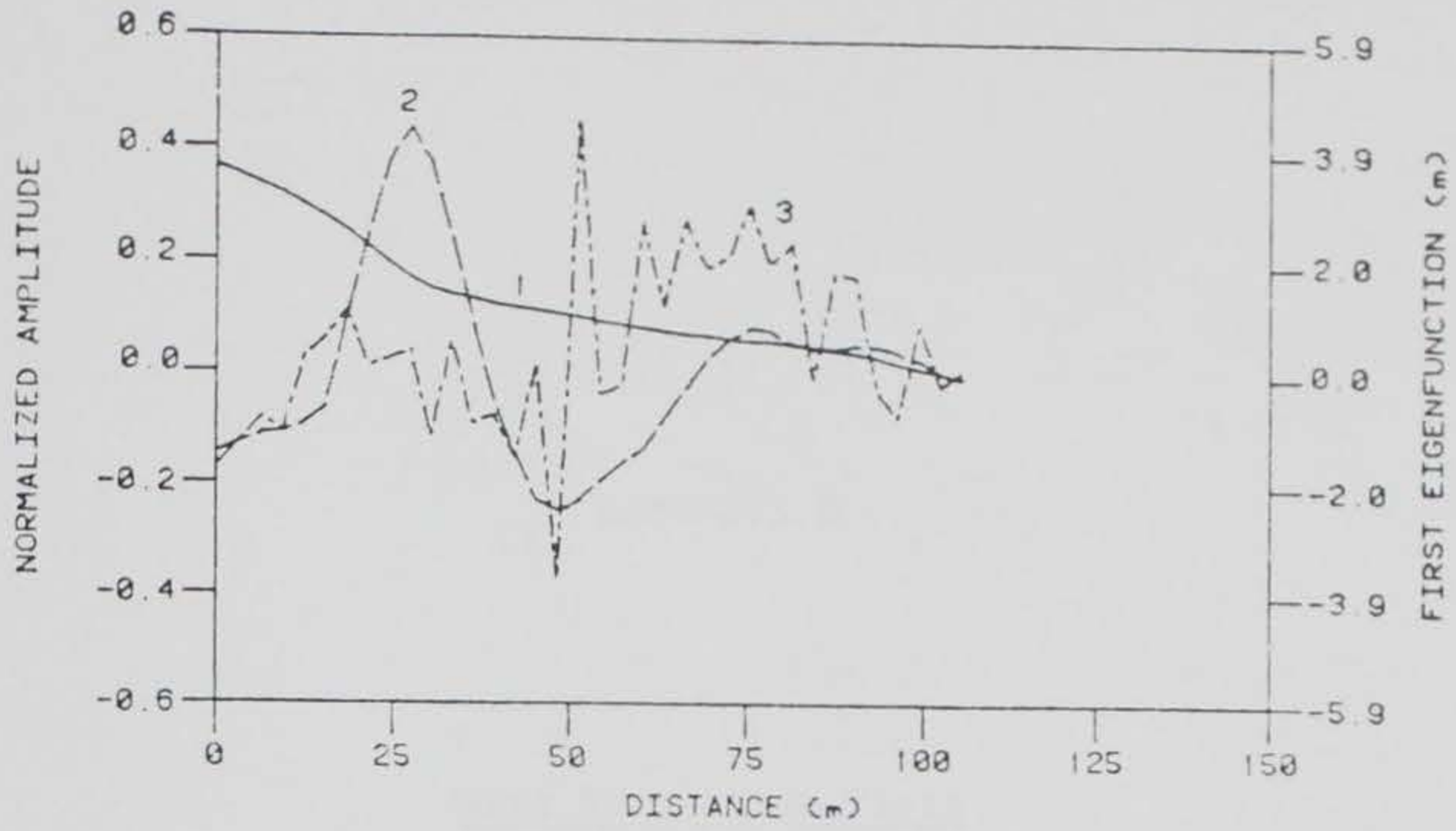

TEMPORAL EIGENFUNCTIONS

PROFILE LINE 3 DATA NOT DEMAANED

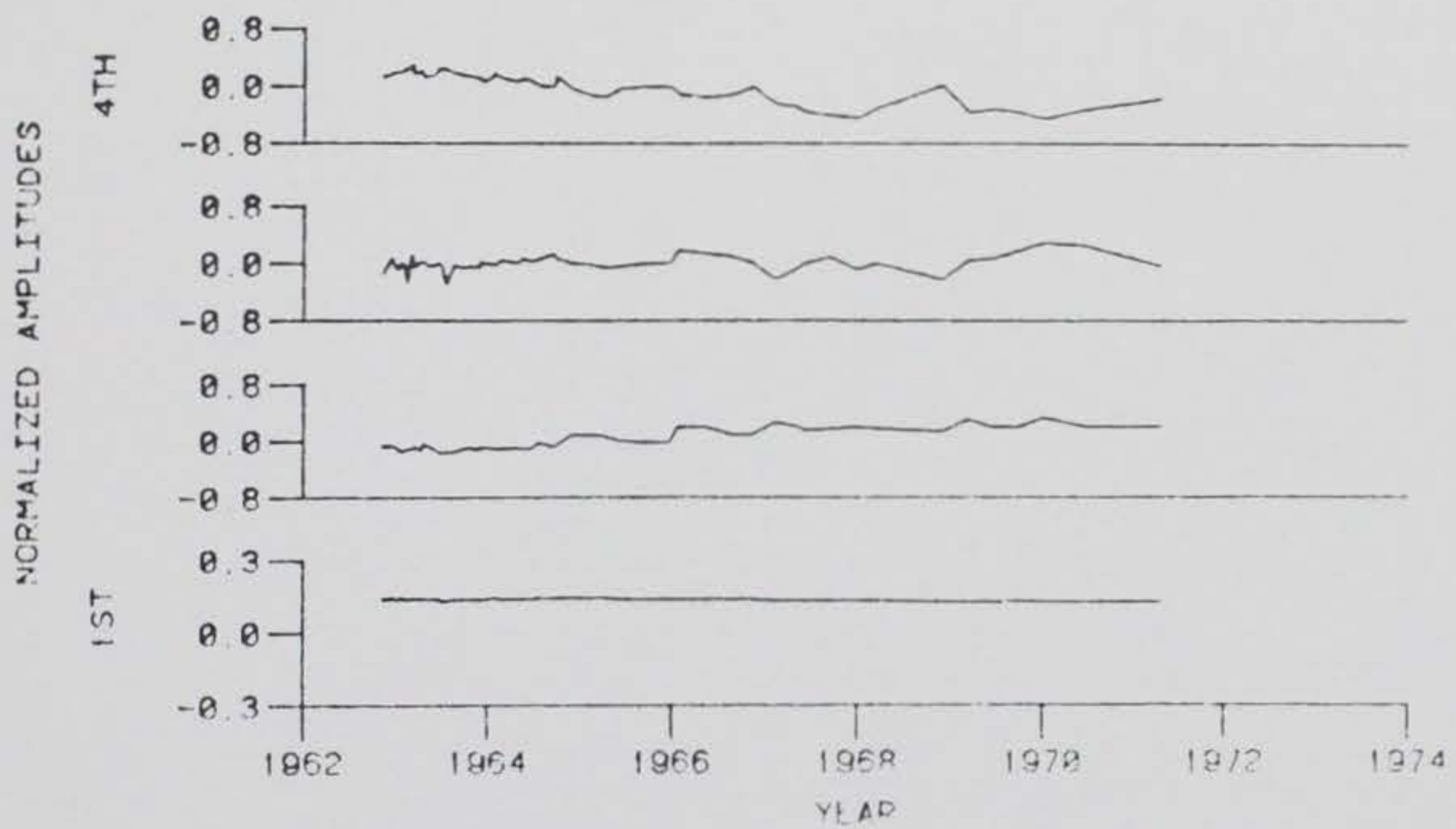

APPENDIX H

Wave Refraction Plots

