

TA7
W34
no.
GL-91-8

y Corps
neers

LIBRARY
USE ONLY

TECHICAL REPORT GL-91-8

ALTERNATIVES FOR CONTROL OF SHORELINE EROSION AT FORT EUSTIS, VIRGINIA

by

Edward B. Perry

Geotechnical Laboratory

Robert D. Carver

Coastal Engineering Research Center

and

Robert L. Lazor

Environmental Laboratory

DEPARTMENT OF THE ARMY

Waterways Experiment Station, Corps of Engineers
3909 Halls Ferry Road, Vicksburg, Mississippi 39180-6199

US-CE-C PROPERTY OF THE
UNITED STATES GOVERNMENT



April 1991

Final Report

Approved For Public Release; Distribution Unlimited

RESEARCH LIBRARY
US ARMY ENGINEER WATERWAYS
EXPERIMENT STATION
VICKSBURG, MISSISSIPPI

Prepared for DEPARTMENT OF THE ARMY
Fort Eustis, Virginia 23604



23946769

TAT
W34
no. GL-91-8

REPORT DOCUMENTATION PAGE			Form Approved OMB No. 0704-0188	
Public reporting burden for this collection of information is estimated to average 1 hour per response, including the time for reviewing instructions, searching existing data sources, gathering and maintaining the data needed, and completing and reviewing the collection of information. Send comments regarding this burden estimate or any other aspect of this collection of information, including suggestions for reducing this burden, to Washington Headquarters Services, Directorate for Information Operations and Reports, 1215 Jefferson Davis Highway, Suite 1204, Arlington, VA 22202-4302, and to the Office of Management and Budget, Paperwork Reduction Project (0704-0188), Washington, DC 20503.				
1. AGENCY USE ONLY (Leave blank)	2. REPORT DATE April 1991	3. REPORT TYPE AND DATES COVERED Final report		
4. TITLE AND SUBTITLE Alternatives for Control of Shoreline Erosion at Fort Eustis, Virginia			5. FUNDING NUMBERS	
6. AUTHOR(S) Edward B. Perry, Robert D. Carver, Robert L. Lazor			MIPR ERCOR274	
7. PERFORMING ORGANIZATION NAME(S) AND ADDRESS(ES) USAE Waterways Experiment Station Geotechnical Laboratory, Coastal Engineering Research Center, Environmental Laboratory 3909 Halls Ferry Road, Vicksburg, MS 39180-6199			8. PERFORMING ORGANIZATION REPORT NUMBER Technical Report GL-91-8	
9. SPONSORING / MONITORING AGENCY NAME(S) AND ADDRESS(ES) Fort Eustis, VA 23604			10. SPONSORING / MONITORING AGENCY REPORT NUMBER	
11. SUPPLEMENTARY NOTES Available from National Technical Information Service, 5285 Port Royal Road, Springfield, VA 22161				
12a. DISTRIBUTION / AVAILABILITY STATEMENT Approved for public release; distribution unlimited			12b. DISTRIBUTION CODE	
13. ABSTRACT (Maximum 200 words) This study gives alternatives for control of shoreline erosion at thirteen sites at Fort Eustis, Virginia. Waves are the major cause of erosion in the study area with design wave heights from 1.0 to 4.0 ft. Design still-water levels are +5.6 ft MLW for the 25-year return period event and +6.2 ft MLW for the 50-year return period event. A total of 13 different structures is presented for possible use at one or more sites, to yield a total of 49 structure-site alternatives. The various types of protection were categorized (low, medium, or high) according to potential environmental problems and relative cost and were assigned a numerical ranking. Advantages and disadvantages of the various types of protection are given along with a sketch for each structure-site combination. General requirements, which are applicable to all types of protection, are presented. Labor-intensive protection and/or the use of locally available materials which could result in significant cost savings are (Continued)				
14. SUBJECT TERMS Shoreline erosion Streambank protection Warwick River Shoreline protection Fort Eustis Streambank erosion James River			15. NUMBER OF PAGES 142	
			16. PRICE CODE	
17. SECURITY CLASSIFICATION OF REPORT UNCLASSIFIED	18. SECURITY CLASSIFICATION OF THIS PAGE UNCLASSIFIED	19. SECURITY CLASSIFICATION OF ABSTRACT UNCLASSIFIED	20. LIMITATION OF ABSTRACT	

13. (Concluded).

delineated. Mitigation banking, as an acceptable form of compensatory mitigation, is described. Cumulative impacts of project sediment erosion and deposition are addressed. The importance of monitoring, to determine whether permit conditions were complied with and whether the purpose of the project or mitigation is achieved, is discussed.

PREFACE

This report gives alternatives for control of shoreline erosion at thirteen sites at Fort Eustis, Virginia.

This project was authorized by the Directorate of Engineering and Housing (DEH), Fort Eustis, Virginia, under Military Interdepartmental Purchase Request Number ERCOR274 dated 24 September 1990. The work was carried out during the period of September 1990 to December 1990. MG Samuel N. Wakefield was Commanding General of Fort Eustis during this period of time.

Dr. Edward B. Perry, Soil and Rock Mechanics Division (S&RMD), Geotechnical Laboratory (GL), US Army Engineer Waterways Experiment Station (WES), was the Principal Investigator. Mr. Michael H. Cochran, DEH, Fort Eustis, was the Technical Monitor for this work.

The work was conducted and this report prepared by Dr. Perry, S&RMD; Mr. Robert D. Carver, Wave Dynamics Division (WDD), Coastal Engineering Research Center (CERC); and Mr. Robert L. Lazor, Environmental Resources Division (ERD), Environmental Laboratory (EL). General supervision was provided by Mr. W. Milton Myers, Chief, Soil Mechanics Branch, Dr. Don C. Banks, Chief, S&RMD, and Dr. William F. Marcuson III, Chief, GL; Mr. D. D. Davidson, Chief, Waves Research Branch, Mr. Claude E. Chatham, Jr., Chief, WDD, and Dr. James R. Houston, Chief, CERC; and Mr. Hollis H. Allen, Leader, Habitat Resources Team, Mr. E. Carl Brown, Chief, Wetlands and Terrestrial Habitat Group, Dr. Conrad J. Kirby, Chief, ERD, and Dr. John Harrison, Chief, EL.

COL Larry B. Fulton, EN, was Commander and Director of WES during the preparation of this report. Dr. Robert W. Whalin was Technical Director.

CONTENTS

	<u>Page</u>
PREFACE.....	1
CONVERSION FACTORS, NON-SI TO SI (METRIC) UNITS OF MEASUREMENT.....	4
PART I: INTRODUCTION.....	5
Background.....	5
Purpose.....	5
Scope.....	5
PART II: DESCRIPTION OF THE SITES.....	7
General.....	7
Grouping of Sites.....	7
PART III: CAUSES OF SHORELINE EROSION.....	9
General.....	9
Waves.....	9
Currents.....	10
Water Level Variations.....	10
Determination of Design Still-Water Levels.....	12
Estimation of Design Wave Heights.....	13
PART IV: SHORELINE EROSION PROTECTION.....	18
Types of Protection Considered.....	18
Types of Protection Selected.....	18
Labor-Intensive Protection and/or Locally Available Materials.....	28
Mitigation.....	29
Cumulative Impacts of Project Sediment Erosion and Deposition.....	31
Monitoring.....	31
PART V: SUMMARY AND RECOMMENDATIONS.....	33
Summary.....	33
Recommendations.....	34
REFERENCES.....	36
TABLES 1-13	
FIGURES 1-66	
GLOSSARY	

CONVERSION FACTORS, NON-SI TO SI (METRIC)
UNITS OF MEASUREMENT

Non-SI units of measurement used in this report can be converted to SI (metric) units as follows:

<u>Multiply</u>	<u>By</u>	<u>To Obtain</u>
cubic feet	0.02831685	cubic metres
cubic yards	0.7645549	cubic metres
Fahrenheit degrees	5/9	Celsius degrees or Kelvins*
feet	0.3048	metres
gallons (US dry)	0.004404884	cubic decimetres
gallons (US liquid)	3.785412	cubic decimetres
inches	2.54	centimetres
kips (force) per square inch	6.894757	megapascals
pounds (force) per square inch	6.894757	kilopascals
pounds (mass)	0.4535924	kilograms
pounds (mass) per cubic foot	16.01846	kilograms per cubic metre
pounds (mass) per cubic yard	0.5932764	kilograms per cubic metre
miles per hour	0.86898	knots
square inches	6.4516	square centimetres

* To obtain Celsius (C) temperature readings from Fahrenheit (F) readings, use the following formula: $C = (5/9)(F - 32)$. To obtain Kelvin (K) readings, use: $K = (5/9)(F - 32) + 273.15$.

ALTERNATIVES FOR CONTROL OF SHORELINE

EROSION AT FORT EUSTIS, VIRGINIA

PART I: INTRODUCTION*

Background

1. Fort Eustis, Virginia, is located on Mulberry Island which is bordered by the James River on the west side and the Warwick River on the east side (Figure 1). Portions of the shoreline along the James and Warwick Rivers bordering Fort Eustis, Virginia, are experiencing significant erosion due to wave and/or current attack.

Purpose

2. The purpose of this study was to provide alternatives for control of shoreline erosion at thirteen sites at Fort Eustis, Virginia.

Scope

3. The scope of this study was to study the problem at each site using existing information such as maps, aerial photographs, etc.; to estimate the maximum wave heights and current velocities

* Terms used in this report which may not be familiar to the reader are defined in the Glossary.

for each of the thirteen sites; to identify alternate types of protection, including vegetation where applicable, for use at the thirteen sites with at least three alternative concepts per site, identify the advantages and disadvantages of each type of protection, rank the types of protection in terms of relative cost, and provide a conceptual sketch for each type of protection.

PART II: DESCRIPTION OF THE SITES

General

4. Thirteen sites were investigated. As shown in Figure 2, eight of these sites are located on the James River and the remaining five sites are on the Warwick River. As summarized in Table 1, eroded lengths varied from 75 to 1200 ft, bank heights ranged from 3 to 18 ft above mean low water (MLW), and bank slopes ranged from vertical to 1H:1V. Also, as will be verified in Part III, one would expect design wave conditions to vary to some extent.

Grouping of Sites

5. In the interest of efficiency, it was decided to form several common groups of sites. Grouping, based primarily on geometric similarity and expected wave conditions, is summarized as follows:

<u>Group</u>	<u>Site Numbers</u>	<u>River</u>
1	1	James
2	2, 2A	↓
3	3, 4	
4	5	Warwick
5	6, 7	
6	8	↓
7	9, 10	
8	brickyard	
9	11	

Plan and elevation (sectional) views of individual sites are

presented in Figures 3 through 15.

PART III: CAUSES OF SHORELINE EROSION

General

6. In order to investigate problems in the study area, it is necessary to first identify natural forces affecting the area. These factors are described in this part.

Waves

7. While waves are always present on the open coast, they are not continuous in sheltered waters. However, they are the major cause of erosion in these areas. Understanding how wave action influences shoreline processes requires familiarity with several basic characteristics of waves, including height, period, and length (Figure 16). Wave height is the vertical distance between the wave crest and trough. Wave period is the time it takes two successive wave crests to pass a stationary point, and wavelength is the distance between successive crests.

8. The actual process of wave generation depends on several important factors, the most prominent being wind, although pleasure craft and large vessels also cause significant wave activity in the form of wakes. The height of wind-driven waves depends on the wind speed, duration, fetch length, and water depth. Wind speed is obviously important, but duration must also be considered because wind action must be sustained for wave

growth. Fetch is the over-water distance wind travels while generating waves. At a given site, the maximum fetch length is generally the most important parameter. Less important, but still critical, is the average water depth along the fetch. Deeper water allows for somewhat larger waves because of decreased bottom friction. Design wave conditions will be developed later in this part (US Army Corps of Engineers 1989c).

Currents

9. The water at the shore is constantly in motion due to currents as well as waves. Tides produce currents in sheltered bays connected to the open ocean. As the tide begins to rise in the ocean (flood tide), the bay's water surface elevation lags behind, generating a current into the bay. As the tide falls (ebbs), the ocean surface drops more quickly so that the bay surface becomes higher and current flows out of the bay. The maximum tidal currents in the study area (3 ft per second) are by themselves not strong enough to cause erosion problems (Herbich et al. 1984).

Water Level Variations

10. The still-water level (SWL), or water level with no waves present, changes because of astronomical tides and storms. Tides are generated in ocean basins by gravitational attraction

between the earth, moon, and sun, and are classified as diurnal, semidiurnal, or mixed. Diurnal tides have only one high and low each day, while semidiurnal tides have two approximately equal highs and two approximately equal lows daily. Mixed tides, on the other hand, exhibit a distinct difference in the elevation of either successive highs or successive lows. In addition, at locations with mixed tides, the characteristics of the tide may change to diurnal or semidiurnal at certain times during the lunar month.

11. The tide range, or difference between the high and low, tends to fluctuate throughout the lunar month. Spring tides have larger than average ranges while neap tides have smaller ranges. Spring tides occur with full and new moons because the gravitational attractions of both the sun and moon act along the same line, tending to exaggerate the difference between high and low tides. Differences in tidal range also are caused by the varying distance to the moon as it orbits the earth, declination of the moon, and declination of the sun.

12. Storms tend to increase the still-water level because of atmospheric pressure differences and high winds. Atmospheric pressure differences across a large water body commonly can cause one or two foot rises in the water level in the lower pressure area. Stress on the water's surface from high storm winds also tends to drive the water on shore to above normal levels (storm setup) until balanced by the tendency for the water to flow back to a lower level (Douglass 1990).

Determination of Design Still-Water Levels

Tides

13. Tidal fluctuation at Mulberry Island varies between 2 and 3 ft. For design purposes, a spring tide was assumed with a tidal elevation of +3.2 ft Mean Low Water (MLW) (Langley AFB 1991).

Wave setup

14. Wave setup is superelevation of the water surface above normal surge elevation due to onshore mass transport of water by wave action alone. For the area under consideration, 25- and 50-year return period wave setups of 0.4 and 0.5 ft are typical and will be assumed applicable to this project (US Army Engineer Districts, Baltimore and Norfolk, State of Maryland, Commonwealth of Virginia 1990).

Surge

15. For the study area, 25- and 50-year storm surges of 2.0 and 2.5 ft are typical and thus were incorporated into design of this project (US Army Corps of Engineers 1989c; US Army Engineer Districts, Baltimore and Norfolk, State of Maryland, Commonwealth of Virginia 1990).

Design still-water level

16. The design still-water level for the 25-year event is thus the sum of design tide, wave setup, and surge or $3.2 \text{ ft} + 0.4 \text{ ft} + 2.0 \text{ ft} = +5.6 \text{ ft MLW}$. Similarly, for the 50-year design, the still-water level is $3.2 \text{ ft} + 0.5 \text{ ft} + 2.5 \text{ ft} = +6.2$

ft MLW. Note from Figures 3 to 15 that the design still-water level exceeds the bank elevation for all sites except site 1 and site 11.

Estimation of Design Wave Heights

General

17. Design wave heights for sites such as those under study may be controlled by maximum wind driven waves, maximum depth limited waves, or local sources such as boat wake.

Wind driven waves - James River sites - 50-year event

18. As discussed earlier in this part, the height of wind driven waves depends primarily on wind speed, fetch length, and water depth. Eroded sites on the James River side of Mulberry Island are primarily exposed to wind waves over the 90 degree sector from south to west. Assuming inputs and estimated wave conditions approaching site 3 are representative of all the James River sites, wave conditions would be as follows:

<u>Direction</u>	<u>Wind Speed* knots</u>	<u>Fetch miles</u>	<u>Average Depth Along Fetch ft</u>	<u>Predicted Wave Period sec</u>	<u>Height ft</u>
S	57	4.5	16	4.3	6.3
SW	58	5.0	14	4.4	6.1
W	57	4.0	15	4.2	5.9

* Based on values measured at Langley AFB (Langley AFB 1991)

Wind driven waves - James River sites - 25-year event

19. Assuming inputs and estimated wave conditions

approaching site 3 are representative of all the James River sites, wave conditions would be as follows:

<u>Direction</u>	<u>Wind</u>		<u>Average Depth Along Fetch ft</u>	<u>Predicted Wave</u>	
	<u>Speed*</u> <u>knots</u>	<u>Fetch</u> <u>miles</u>		<u>Period</u> <u>sec</u>	<u>Height</u> <u>ft</u>
S	47	4.5	15.4	3.9	4.9
SW	48	5.0	13.4	4.0	4.9
W	47	4.0	14.4	3.8	4.7

* Based on values measured at Langley AFB (Langley AFB 1991)

Depth limited waves - James River sites

20. The design water depth at site 3 for the 50 year event is approximately 5.2 ft (+6.2 ft MLW surge less a toe depth of +1.0 ft MLW). The maximum wave height that can be supported in a given water depth varies from 60 to 80 percent of the depth, depending primarily on wave period and bottom slope. Assuming a height to depth ratio of 0.75, the maximum stable wave height is $(0.75)(5.2 \text{ ft}) = 3.9 \text{ ft}$. Similar reasoning for the 25 year event yields a maximum wave height of $(0.75)(4.6 \text{ ft}) = 3.5 \text{ ft}$.

Boat wake - James River sites

21. Commercial and military craft of the type using this section of the James River typically create waves of 3 ft or less in height.

Summary - James River sites

22. Since the maximum wind driven wave heights are considerably greater than can be supported in the design depths, the design wave heights for the 25 and 50 year events for site 3

are chosen to be 3.5 and 4 ft (the 3.9 ft depth limited value, rounded to 4 ft), respectively. Fetch lengths and water depths approaching the other sites are all similar enough to site 3 that maximum wind generated waves can be assumed to be well in excess of depth limited wave heights at each of these sites. Therefore, depth limited wave heights will be used for design at all James River sites.

Wind driven waves - Warwick River sites - 50-year event

23. Eroded sites on the Warwick River side of Mulberry Island are primarily exposed to wind waves over the 135 degree sector from north to southeast. Assumed inputs and estimated wave conditions approaching site 8 (the most exposed site) are as follows:

<u>Direction</u>	<u>Wind Speed* knots</u>	<u>Fetch miles</u>	<u>Average Depth Along Fetch ft</u>	<u>Predicted Wave Period sec</u>	<u>Height ft</u>
N	56	0.9	8	2.62	3.16
NE	60	0.5	9	2.29	2.93
E	60	0.6	9	2.42	3.14
SE	55	0.9	9	2.61	3.19

* Based on values measured at Langley AFB (Langley AFB 1991)

Wind driven waves - Warwick River sites - 25-year event

24. Assumed inputs and estimated wave conditions approaching site 8 (the most exposed site) are as follows:

<u>Direction</u>	<u>Wind</u>		<u>Average Depth Along Fetch ft</u>	<u>Predicted Wave</u>	
	<u>Speed*</u> <u>knots</u>	<u>Fetch</u> <u>miles</u>		<u>Period</u> <u>sec</u>	<u>Height</u> <u>ft</u>
N	46	0.9	7.4	2.36	2.40
NE	50	0.5	8.4	2.08	2.23
E	50	0.6	8.4	2.19	2.39
SE	45	0.9	8.4	2.34	2.41

* Based on values measured at Langley AFB (Langley AFB 1991)

Depth limited waves - Warwick River sites

25. The design water depth at all sites is sufficient to support the maximum wind driven waves calculated in paragraphs 23 and 24.

Boat wake - Warwick River sites

26. Small to medium size pleasure craft of the type using the Warwick River typically create waves of 1 ft or less in height.

Summary - Warwick River sites

27. At site 8 a design wave height of 3.2 ft (maximum wind wave of 3.19 ft rounded to 3.2 ft) will be used for the 50 year event and a design height of 2.5 ft (maximum wind wave of 2.41 rounded to 2.5 ft) will be used for the 25 year event. Sites 9, 10, 11, and the brickyard, located upstream in a narrow portion of the river, are probably not subjected to wind waves of significant height. Therefore, the assumed boat wake wave height of 1 ft will be used for design at these sites.

Design wave conditions

28. A summary of the design wave conditions for the thirteen sites is given in Table 2. Waves are the major cause of

erosion in the study area.

PART IV: SHORELINE EROSION PROTECTION

Types of Protection Considered

29. From an environmental viewpoint it is desirable to consider a wide range of types of protection. Subsequently certain types of protection may be shown to be inappropriate for various reasons and dropped from consideration. A number of shoreline erosion protection methods were considered for possible use at each group of sites as shown in Table 3. These included regulation of boat traffic, site preparation, drainage control, vegetation, geocomposite mattress, graded riprap revetment, broken concrete revetment, other revetment, bulkheads, retards, longitudinal dike, beach nourishment, island creation, bank failure protection, segmented offshore breakwater, segmented low-crested breakwater, sill, and floating breakwater. Due to the remoteness of most sites, cast-in-place concrete structures were not considered (US Army Engineer Waterways Experiment Station 1981a, Brown 1985, Dennis 1988, Hardaway and Anderson 1980). The advantages and disadvantages of various types of protection are given in Table 4.

Types of Protection Selected

General

30. As shown in Table 3, several types of protection were

not selected for various reasons. Self-forming (windrow and/or trench-fill) revetment were not considered applicable because of difficulty in establishing a stable bank angle under wave action, particularly for the relatively low (less than 5 ft) bank heights involved (US Army Corps of Engineers 1981b). Longitudinal dikes (similar to rubble-mound seawall) were not considered to offer adequate protection for the wave heights involved. Island creation by maintenance dredging is experimental and would require long-term study. Bank failure protection (slope flattening and/or benching and retaining walls) is not necessary because internal stability of the bank is not a problem. A conventional segmented offshore breakwater would be more expensive and too conservative compared to a segmented low-crested breakwater. A sill (continuous low-crested breakwater) would be more expensive compared to a segmented low-crested breakwater and would adversely affect water circulation. Floating breakwaters are not recommended due to shallow water conditions that would result in grounding at low tide (US Army Corps of Engineers 1981c, 1984, 1986).

31. The types of protection selected as viable options for each group of sites are indicated in Table 3. The various types of protection selected for each group of sites were categorized (low, medium, or high) according to potential environmental problems and relative cost and assigned a numerical ranking as shown in Tables 5 to 13 for Groups 1 to 9, respectively. Sketches of the various types of protection are given in Figures

17 to 66.

General Requirements

32. There are a number of general requirements which should be addressed in any shoreline protection method. These include allowance for changes in site conditions between design and construction, timing of completion of construction (especially important with vegetation), extensions (or tiebacks) at upstream and downstream ends of protection to "tie" the structure into the bank and prevent flanking, consideration of overtopping, and design against vandalism (US Army Engineer Waterways Experiment Station 1985a).

Description of Protection Methods

33. Regulation of Boat Traffic. Water craft speed reduction to control navigation traffic impacts to shoreline erosion at the brickyard site could be accomplished through the posting of appropriate signs on the Warwick River to warn of entry into a delineated no wake zone. Both upstream and downstream approaches to the no wake zone should be established through normal installation regulatory processes.

34. Site Preparation - Grade Bank to Stable Slope. As noted in Table 1 the bank slopes range from vertical to 1V:1H. Many types of protection require that the bank be graded to a stable slope (angle depending upon soil conditions) prior to construction of protection. Often some fill material must be placed to obtain the desired slope angle. A stable slope is required for geocomposite mattresses and all types of revetments

(US Army Corps of Engineers 1985).

35. Drainage Control. Diversion of runoff at the top of the bank is required when high (greater than 5 ft) banks with vertical slopes are present (sites 1, 5, and 11). This prevents gullying and sheet erosion caused by upland runoff and reduces potential for excess hydrostatic water pressures within the bank (US Army Corps of Engineers 1981a, 1981b).

36. Vegetation. Until recently salt marsh vegetation has been restricted to planting in the intertidal zone. However, certain salt tolerant wetland species [saltmeadow cordgrass (*Spartina patens*)] colonize and grow well above the intertidal zone and may be considered in formulating alternatives to minimize overtopping, flanking or undermining of hardened structures. Some important factors to consider in vegetation use are (Allen and Klimas 1986):

- a. species selection
- b. planting methods
- c. planting times (windows)
- d. acquisition of plant materials
- e. plant handling and care
- f. maintenance and replacement

Detailed information and guidance on the use of salt marsh vegetation in the Virginia and North Carolina coastal area in moderate to low energy environments is available (Broome, Seneca, and Woodhouse 1988). Additionally, Ft. Eustis is located near a number of commercial marsh planning and planting companies.

37. Geocomposite Mattress. Specialty geocomposites have been developed for the purpose of erosion control. Geocomposite mattresses on prepared slopes used in concert with vegetation can be an economical stabilization technique (Koerner 1990).

38. Riprap Revetment. The general requirements for single component revetments are durability, erosion resistance, permeability and filtering, flexibility, weight or anchorage, and natural roughness similar to that of the bank. Stone revetments, a proven method of shoreline protection, satisfy all of the above-mentioned requirements. They are durable and can be relatively inexpensive if there is a local source of armor stone. Such stone should be clean, hard, dense, durable, and free of cracks and cleavages. The armor stone size is a function of bank slope, wave height, and stone density. Assuming the bank is graded to a 1:2.5 slope and 165 pcf stone is available, the 4 ft design wave height (James River side) would require 300 lb armor stone for stability (US Army Corps of Engineers 1985, 1986).

39. Since it is not possible to obtain stone of exactly the same weight, a range of permissible sizes must be specified. For any given required weight, W , stones ranging from $0.75W$ to $1.25W$ can be used, but at least 75% should weigh W or more (US Army Corps of Engineers 1985, 1986). As shown in Figures 19 through 30, stone revetments are recommended as an alternative at all sites, with the exception of the brickyard. The 300-lb armor is recommended in concert with the 1:2.5 slope at sites 2, 2A, 3, 4, 5, 6, 7, and 8. Due to the higher bank at site 1, a steeper

slope (1V:2H) was used to minimize excavation (see Figure 10). This steeper slope and one layer of armor would require 1,000-lb stone. Sites 9, 10, and 11 can use 30-lb underlayer stone as armor (US Army Corps of Engineers 1984, 1985; US Army Engineer Waterways Experiment Station 1981c, 1985b; Fulton-Bennett and Griggs 1986).

40. Broken Concrete Revetment. A concrete rubble revetment utilizes a waste product otherwise difficult to dispose of in an environmentally acceptable manner. Concrete rubble from the Fort Eustis dump, if available in sufficient quantity, could be used. It would be necessary to burn off all protruding reinforcing bars and some additional processing (breaking into smaller pieces) would be required to insure that long or side slab-like pieces do not exist that would cause bridging or large cavities in or under the rubble. This can usually be accomplished if the longest dimension of an individual piece of concrete rubble is no greater than three times the shortest. Proposed structures for sites 9, 10, and 11 are given in Figures 31, 32, and 33 (US Army Corps of Engineers 1981c, 1981d, 1981e, 1985).

41. Other Revetment. In addition to riprap and broken concrete, other revetment types include used auto tire mattress, sand-cement sack revetment, interlocking concrete blocks, and gabions (vinyl-coated wire).

42. Used auto tire mattresses consist of connected scrap tires placed on a filter and filled with concrete for ballast. Such structures can be durable, flexible, and inexpensive

49. Treated timber bulkheads are formed from horizontal, pressure-treated planks spiked to the landward side of posts that are anchored to deadman or piles in the backfill (Figure 56). The planks must be backed by filter cloth or graded filter stone to prevent soil loss through the cracks. Again, site 5 is a candidate for this type structure.

50. Sheetpile bulkheads consist of interconnecting or very tightly spaced sheets of material driven vertically into the ground. The sheeting can be made of steel, aluminum, or timber. Sheetpile structures are either cantilevers or anchored. A cantilever bulkhead is a sheetpile wall supported solely by ground penetration, making it susceptible to failure from toe scour. An anchored or braced bulkhead is similar to a cantilever structure, but gains additional support against seaward deflection from embedded anchors. The advantages of sheetpile bulkheads are their long and relatively maintenance-free life and their uniform appearance. Their disadvantages include special pile-driving equipment and trained operators required to install them. The equipment requires a fairly wide access route and ample maneuvering room at the site. Figure 57 shows a steel sheetpile structure that could be used at site 5.

51. Steel H-piles and railroad ties with cap can be used to form bulkheads. This system utilizes vertical steel piles that are H-shaped in section. Railroad ties are placed horizontally between the piles and a steel channel is welded to the top. A structure of this type could also be used at site 5 (Figure 58).

52. Retard - Used Auto Tire Post. Closely spaced vertical poles can be strung with used tires to form an inexpensive structure. Tires are advantageous because they are durable and are available free in most areas. Figures 59 through 63 show structures that may be considered for sites 1, and 5 through 8, respectively. Retards are positioned in plan so as to achieve a desired alignment of the bank. Tiebacks (spurs connecting the retard structure to the bank), as shown in Figure 64, are used unless the retard is constructed directly against the toe of the existing bank. Tiebacks increase structural stability and induce sedimentation following overtopping (Combe et al 1989, US Army Corps of Engineers 1981a 1981b).

53. Beach Nourishment. Sand recovered from navigation channels by maintenance dredging now often is perceived as a resource, not a waste product. Beach nourishment involves placing sand on the shoreline by mechanical means, such as dredged material disposal or overland hauling and dumping by trucks. The beach fill functions as an eroding buffer zone. As large waves strike it, sand is carried offshore and deposited in a bar. As the bar grows, it causes incoming waves to break farther offshore. The useful life of such a beach can be completely eliminated in a short period of time by a rapid succession of storm waves. Beach fills generally have a fixed initial cost (advantage) but an uncertain periodic maintenance cost (disadvantage) (Landin 1987; US Army Corps of Engineers 1987; US Army Engineer Waterways Experiment Station 1981b, 1981e,

1986a, 1988b; Virginia Institute of Marine Science 1987).

54. Segmented Low-Crested Breakwater - Riprap. A bottom-connected, rubble-mound breakwater could be utilized to provide the desired protection. Figures 65 and 66 show structures that could be used at sites 3 and 4. These structures would be situated 75 to 100 ft offshore and constructed to a crown elevation of +5 ft MLW. These structures are normally constructed with intermediate gaps about equal to the structures' length. Structures of this type typically have a rather high initial cost; however, maintenance costs are normally low, thus yielding reasonable life-cycle costs (Rosati 1990; US Army Corps of Engineers 1986; US Army Engineer Districts, Baltimore and Norfolk, State of Maryland, Commonwealth of Virginia 1990; US Army Engineer Waterways Experiment Station 1981f, 1984, 1987, 1988a, 1990).

Labor-Intensive Protection and/or
Locally Available Materials

55. A total of 13 different structures are presented for possible use at one or more of the sites to yield a total of 49 structure-site alternatives. Significant savings can be achieved if volunteer or troop labor is available and/or if there are locally available materials that can be used for a savings over imported materials. Labor-intensive techniques include:

- a. Drainage Control - Diversion of Runoff at top of bank.

- b. Vegetation.
- c. Riprap Revetment - Placed Revetment.
- d. Broken Concrete Revetment - Placed Revetment.
- e. Other Revetment - Used Auto Tire Mattress, Sand-Cement Sack Revetment, Interlocking Concrete Block, Gabion (Vinyl-Coated Wire).
- f. Bulkheads (w or w/o Toe Protection) - Used Auto Tires and Timber Post, Gabions (Vinyl-Coated Wire), Treated Timber, Steel Sheetpiling, Steel H-Piles and Railroad Ties with Cap.
- g. Retard - Used Auto Tire Post.
- h. Beach Nourishment - Truck in Sand (Road Required).

56. Locally available materials which may be available for use in constructing shoreline erosion protection include:

- a. Vegetation
- b. Broken Concrete - Placed Revetment.
- c. Used Auto Tires - Other Revetment (Mattress), Bulkheads (Used Auto Tires and Timber Post), Retards (Used Auto Tire Post).
- d. Sand-Cement Sacks - Other Revetment.
- e. Gabions Filled With Small Stones or Rubble - Other Revetment, Bulkheads.
- f. Treated Timber - Bulkheads
- g. Steel H-Piles and Railroad Ties with Cap - Bulkheads
- h. Sand - Beach Nourishment (Truck in Sand - Road Required).

Mitigation

57. Mitigation is defined as avoiding, minimizing or

compensating for unavoidable adverse environmental impacts resulting from a proposed project. A 1989 Memorandum of Agreement (MOA) between the US Army Corps of Engineers (Corps) and the US Environmental Protection Agency (EPA) requires sequencing, i.e. consideration of avoidance first, then minimization, and finally compensation for unavoidable adverse project impacts (Page and Wilcher 1989). Compensatory mitigation consists of many types of mitigation and includes wetlands restoration, development, enhancement, exchange and preservation. Exchange and preservation are generally considered to result in the net loss of wetlands and therefore conflict with existing "no net loss of wetlands" policy (Schnick et.al. 1982).

58. Mitigation banking is defined as wetland restoration, creation or enhancement undertaken expressly for the purpose of providing compensation credits for wetland losses from future development activities (Page and Wilcher 1989). Mitigation banking may be an acceptable form of compensatory mitigation. Where mitigation banking has been approved by the Corps and EPA on a District by District basis, use of that mitigation bank for those particular projects may be considered as meeting the requirements of the 404 (b)(1) Guidelines which are established as the environmental standard for Section 404 permit issuance under the Clean Water Act. Additional specific guidance on mitigation banking for projects is currently under consideration by the Corps and EPA. General guidance is given in EM 1110-2-

Cumulative Impacts of Project Sediment
Erosion and Deposition

59. Shorelines are subjected to many diverse and dynamic conditions which influence sediment transport and result in erosion and/or deposition on both a short and long-term basis. Generally, nature establishes an equilibrium between these two opposing forces through complex mechanisms which results in alternating areas of erosion and deposition. The physical laws which regulate these forces are consistent in nature. Proposed project activities should consider the cumulative impacts of the project in altering erosion and deposition from both within and outside project boundaries. Increased shoreline erosion or sediment deposition outside project boundaries, as a direct or indirect effect of the project, is an important consideration for permitting purposes. The cumulative impacts of the project are considered in the Clean Water Act (Section 404) permitting program.

Monitoring

60. Monitoring is an important aspect in determining

* Additional information concerning possible mitigation banking at Fort Eustis should be directed to the Regulatory Branch (CENAO-OP-P) ATTN: Mr. Kenneth Kimidy, US Army Engineer District, Norfolk, Construction-Operations Division, 803 Front Street, Norfolk, VA 23510-1096 (AC 804 462-7832).

project and mitigation success, especially in areas of scientific uncertainty. Monitoring may be directed toward determining whether permit conditions are complied with and whether the purpose of the project or mitigation is actually achieved. The physical condition of the structure should be periodically evaluated so that any necessary repairs can be undertaken in a timely manner. Inspections should note such things as stone (or broken concrete, auto tires, sand-cement sacks, interlocking concrete blocks) displacement from revetments and/or bulkheads, possible damage to gabion wire on revetment and/or bulkheads, rotation or slippage of gravity structures, and erosion at the ends of structures (flanking). Long-term monitoring, reporting and potential remedial action may be required for projects involving mitigation with relatively high levels of uncertainty. Project monitoring at Fort Eustis sites to determine shoreline method performance may follow simplified technical guidance (Gatto 1988). Example methods for documentation of shoreline erosion control methods may include the use of erosion control monitoring pins (Gatto 1988). Additional guidance on monitoring and reporting on streambank erosion control methods is available (Pickett and Brown 1977).

PART V: SUMMARY AND RECOMMENDATIONS

Summary

61. This study gives alternatives for control of shoreline erosion at thirteen sites at Fort Eustis, Virginia. Eight of these sites are located on the James River and five are on the Warwick River. The natural forces affecting the area were identified. Maximum tidal currents (3 ft per second) are by themselves not strong enough to cause erosion problems. Design still-water levels are +5.6 ft MLW for the 25-year return period and +6.2 ft MLW for the 50-year return period. Design wave heights ranged from 1.0 to 4.0 ft. Waves are the primary cause of erosion in the study area.

62. General requirements, which are applicable to all types of protection, are presented. A total of 13 different structures is presented for possible use at one or more sites, to yield a total of 49 structure-site alternatives. The various types of protection were categorized (low, medium, or high) according to potential environmental problems and relative cost and assigned a numerical ranking. Advantages and disadvantages of the various types of protection are given along with a sketch for each structure-site combination. Labor-intensive protection and/or locally available materials which could result in significant cost savings are delineated.

63. Mitigation banking, as an acceptable form of

compensatory mitigation, is described. Cumulative impacts of project sediment erosion and deposition were addressed. The importance of monitoring, to determine whether permit conditions were complied with and whether the purpose of the project or mitigation was achieved, was discussed.

Recommendations

64. The following recommendations are made:

- a. Design of the protection method selected for the shoreline erosion sites should consider design still-water levels of +5.6 ft and +6.2 ft MLW for 25- and 50-year return periods, respectively, and design wave heights which ranged from 1.0 to 4.0 ft for various sites.
- b. Selection of the structure to be used at each shoreline erosion site should consider the ranking presented in Tables 5 to 13 which is based on potential environmental problems and relative cost.
- c. The use of volunteer or troop labor (to the extent permitted by law) and locally available materials should be considered in structure selection to minimize construction costs.
- d. The following general requirements should be considered in selection and design of each protection method: allowance for changes in site conditions between design and construction, timing of completion of construction (especially important with vegetation), extensions or tiebacks at upstream and downstream ends of protection to prevent flanking, consideration of overtopping, and design against vandalism.
- e. Mitigation, as defined in terms of avoiding, minimizing or compensating for unavoidable adverse environmental impacts resulting from a proposed project, should be addressed using guidelines established in the MOA between EPA and CE dated 15 December 1989. Mitigation banking, as an acceptable form of compensatory mitigation, should

be investigated.

- f. A cumulative impact assessment of the erosion control program's effects on shoreline erosion and/or deposition should be made as required by the Clean Water Act (Section 404).
- g. A monitoring program, to include baseline characterizations at each site, should be carried out to determine whether permit conditions were complied with and whether the purpose of the project or mitigation was achieved.

REFERENCES

- Allen, H. H., and Klimas, C. V. 1986. "Reservoir Shoreline Revegetation Guidelines," Technical Report E-86-13, US Army Engineer Waterways Experiment Station, Vicksburg, Miss.
- Broome, S. W., Seneca, E. D., and Woodhouse, Jr., W. M. 1988. "Tidal Salt Marsh Restoration, Aquatic Botany, Vol 32, pp 1-22.
- Brown, S. A. 1985. "Streambank Stabilization Measures for Highway Engineers," Report No. FHWA-RD-84-100, Federal Highway Administration, McLean, Va.
- Combe, A. J., III, et al. 1989. "Shoreline Erosion Control Demonstration Program - Revisited," US Army Corps of Engineers, Washington, DC.
- Dennis, W. A. 1988. "New River Shore Protection Study," Proceedings of Symposium on Coastal Water Resources, held in Wilmington, North Carolina, Lyke, W. L., and Hoban, T. J., eds., American Water Resources Association, Bethesda, Md., p 1-16.
- Douglass, S. L. 1990. "Estimating Runup on Beaches: A Review of the State of the Art," Contract Report CERC-90-3, US Army Engineer Waterways Experiment Station, Vicksburg, Miss.
- Fulton-Bennett, K., and Griggs, G. B. 1986. "Coastal Protection Structures and Their Effectiveness," Joint publication of the State of California Department of Boating and Waterways and the Marine Sciences Institute of the University of California at Santa Cruz.
- Gatto, L. W. 1988. "Techniques for Measuring Reservoir Bank Erosion," Special Report 88-3, US Army Corps of Engineers Cold Regions Research and Engineering Laboratory, Hanover, N.H.
- Hardaway, S. and Anderson, G. 1980. "Shoreline Erosion in Virginia," Educational Series No. 31, Virginia Institute of Marine Science, Gloucester Point, Va.
- Herbich, J. B., et al. 1984. Seafloor Scour: Design Guidelines for Ocean-Founded Structures, Marcel Dekker, Inc., New York, N.Y.
- Koerner, R. M. 1990. Designing with Geosynthetics, Prentice Hall, Englewood Cliffs, N.J.
- Landin, M. C., ed. 1988. "Beneficial Uses of Dredged Material," Proceedings of the North Atlantic Regional Conference, 12-14 May 1987, Baltimore, Maryland, US Army Engineer Waterways Experiment Station, Vicksburg, Miss.

Langley AFB. 1991. "1990 Climatology Pamphlet," Prepared by Detachment 7, 3 WS (MAC), Langley AFB, Va.

Page, R. W., and Wilcher, L. S. 1989. "Memorandum of Agreement Between the Environmental Protection Agency and the Department of the Army Concerning the Determination of Mitigation under the Clean Water Act Section 404(b)(1) Guidelines," Washington, DC.

Pickett, E. B., and Brown, B. J. 1977. "Guidelines for Monitoring and Reporting Demonstration Projects," Instruction Report H-77-1, US Army Engineer Waterways Experiment Station, Vicksburg, Miss.

Rosati, J. D. 1990. "Functional Design of Breakwaters for Shore Protection: Empirical Methods," Technical Report CERC-90-15, US Army Engineer Waterways Experiment Station, Vicksburg, Miss.

Schnick, R. A., et. al. 1982. "Mitigation and Enhancement Techniques for the Upper Mississippi River System and Other Large River Systems," Resource Publication 149, US Department of the Interior Fish and Wildlife Service, Washington, DC.

US Army Corps of Engineers. 1981a. "Final Report to Congress - Streambank Erosion Control Evaluation and Demonstration Act of 1974, Section 32, Public Law 93-251," Appendix A - Literature Survey, Washington, DC.

_____. 1981b. "Final Report to Congress - Streambank Erosion Control Evaluation and Demonstration Act of 1974, Section 32, Public Law 93-251," Main Report, Washington, DC.

_____. 1981c. "Low Cost Shore Protection," Brochure for Shoreline Property Owners, Washington, DC.

_____. 1981d. "Low-Cost Shore Protection," Final Report of the Shoreline Erosion Control Demonstration Program (Section 54), Washington, DC.

_____. 1981e. "Low Cost Shore Protection," Guide for Engineers and Contractors, 1981, Washington, DC.

_____. 1984. "Shore Protection Manual," 2 Vols., Washington, DC.

_____. 1985. "Design of Coastal Revetments, Seawalls, and Bulkheads," EM 1110-2-1614, Washington, DC.

_____. 1986. "Design of Breakwaters and Jetties," EM 1110-2-2904, Washington, DC.

_____. 1987. "Beneficial Uses of Dredged Material," EM 1110-2-5026, Washington, DC.

- _____. 1989a. "Environmental Engineering for Coastal Protection," EM 1110-2-1204, Washington, DC.
- _____. 1989b. "Retaining and Flood Walls," EM 1110-2-2502, Washington, DC.
- _____. 1989c. "Water Levels and Wave Heights for Coastal Engineering Design," EM 1110-2-1414, Washington, DC.
- US Army Engineer Districts, Baltimore and Norfolk, State of Maryland, Commonwealth of Virginia. 1990. "Chesapeake Bay, Shoreline Erosion Study," 2 Vols., Baltimore, Md.
- US Army Engineer Waterways Experiment Station. 1981a. "Bulkheads - Their Applications and Limitations," Coastal Engineering Technical Note CETN-III-7, Vicksburg, Miss.
- _____. 1981b. "Protective Beaches - Their Applications and Limitations," Coastal Engineering Technical Note CETN-III-11, Vicksburg, Miss.
- _____. 1981c. "Revetments - Their Applications and Limitations," Coastal Engineering Technical Note CETN-III-9, Vicksburg, Miss.
- _____. 1981d. "Seawalls - Their Applications and Limitations," Coastal Engineering Technical Note CETN-III-8, Vicksburg, Miss.
- _____. 1981e. "Selecting Construction Profiles for Initial Placement of Beach Fills," Coastal Engineering Technical Note CETN-II-5, Vicksburg, Miss.
- _____. 1981f. "Shore Protection Selection Criteria," Coastal Engineering Technical Note CETN-III-6, Vicksburg, Miss.
- _____. 1984. "Use of Segmented Offshore Breakwaters for Beach Erosion Control," Coastal Engineering Technical Note CETN-III-22, Vicksburg, Miss.
- _____. 1985a. "Determining Lengths of Return Walls," Coastal Engineering Technical Note CETN-III-25, Vicksburg, Miss.
- _____. 1985b. "Riprap Revetment Design," Coastal Engineering Technical Note CETN-III-1, Vicksburg, Miss.
- _____. 1986a. "Overfill and Renourishment Factors," Coastal Engineering Technical Note CETN-II-15, Vicksburg, Miss.
- _____. 1986b. "Use of Gabions in the Coastal Environment," Coastal Engineering Technical Note CETN-III-31, Vicksburg, Miss.

_____. 1987. "Sizing of Toe Berm Armor Stone on Rubble-Mound Breakwater and Jetty Trunks Designed for Depth-Limited Breaking Waves," Coastal Engineering Technical Note CETN-III-37, Vicksburg, Miss.

_____. 1988a. "Design of Rubble Foundations and Rubble Toe Protection," Coastal Engineering Technical Note CETN-III-39, Vicksburg, Miss.

_____. 1988b. "Wetlands Created for Dredged Material Stabilization and Wildlife Habitat in Moderate to High Wave-Energy Environments," Environmental Effects of Dredging Technical Note EEDP-07-2, Vicksburg, Miss.

_____. 1990. "An Empirical Method for Design of Breakwaters as Shore Protection Structures," Coastal Engineering Technical Note CETN-III-23, Vicksburg, Miss.

Virginia Institute of Marine Science. 1978. "Habitat Development Field Investigations, Windmill Point Marsh Development Site, James River, Virginia," Appendix D, Environmental Impacts of Marsh Development with Dredged Material: Botany, Soils, Aquatic Biology, and Wildlife, Technical Report D-77-23, US Army Engineer Waterways Experiment Station, Vicksburg, Miss.

Table 1

Characteristics of Eroded Sites

<u>Site</u>	<u>Length ft</u>	<u>Bank Height (above MLW) ft</u>	<u>Bank Slope</u>
1	150	18	Vertical to 1V:1H
2	150	4	Vertical
2A	400	4	Vertical
3	650	4	Vertical
4	1200	4	Vertical
5	300	6	Vertical
6	100	3	Vertical
7	100	4	Vertical
8	75	3	Vertical
9	250	4	Vertical
brickyard	300	4	Vertical
10	75	3.5	Vertical
11	150	18	Vertical to 1V:1H

Table 2

Summary of Design Wave Conditions

Site	Length ft	Bank Height (above MLW) ft	Design Wave Height ft	
			25-year life	50-year life
1	150	18	3.5	4.0
2	150	4	↓	↓
2A	400	4		
3	650	4		
4	1200	4		
5	300	6		
6	100	3		
7	100	4		
8	75	3	2.5	3.2
9	250	4	1.0	1.0
brickyard	300	4	↓	↓
10	75	3.5		
11	150	18		

Notes:

1. Design still-water levels are +5.6 ft MLW for the 25-year return period and +6.2 ft MLW for the 50-year return period.
2. Wave heights on the James River exposure are depth limited.
3. Wave heights at site 8 on the Warwick River are fetch limited.
4. Boat wake is presumed to govern at sites 9, 10, 11, and the brickyard, located upstream in a narrow portion of the Warwick River.

Table 3

Types of Protection

<u>Protection Method</u>	Group (Sites)								
	1 (1)	2 (2,2A)	3 (3,4)	4 (5)	5 (6,7)	6 (8)	7 (9,10)	8 Brickyard	9 (11)
<u>Regulation of Boat Traffic</u>									
Boat Speed and/or Horsepower								X*	
Off-Limit Zones								X	
<u>Site Preparation</u>									
Remove Trees Within 2X Bank Height									
Grade Bank to Stable Slope		X	X	X	X	X	X		
<u>Drainage Control</u>									
Diversion of Runoff at Top of Bank	X			X					X

(Continued)

* Indicates protection method is considered a viable option.

Table 3 (Continued)

Protection Method	Group (Sites)								
	1 (1)	2 (2,2A)	3 (3,4)	4 (5)	5 (6,7)	6 (8)	7 (9,10)	8 Brickyard	9 (11)
<u>Vegetation</u>									
Upper 1 ft above MHT of Upper Bank		X	X	X			X		X
Upper 2/3 of Intertidal Zone (ML to MH Tide)							X	X	X
<u>Geocomposite Mattress (w/ Vegetation)</u>									
Biodegradable									
HoldGro**							X		
Geojute**							X		
Ero-Mat**							X		
Excelsior Blanket**							X		

(Continued)

** Citation of trade names does not constitute an official endorsement or approval of the use of such commercial products.

Table 3 (Continued)

<u>Protection Method</u>	Group (Sites)								
	1 (1)	2 (2,2A)	3 (3,4)	4 (5)	5 (6,7)	6 (8)	7 (9,10)	8 Brickyard	9 (11)
<u>Geocomposite Mattress (w/ Vegetation)</u>									
Non-Biodegradable									
Enkamat**							X		
Miramat**							X		
Tensarmat**							X		
<u>Riprap Revetment</u>									
Placed Revetment	X	X	X	X	X	X	X		X
Self-Forming Revetment									
Windrow									
Trench-Fill									

(Continued)

** Citation of trade names does not constitute an official endorsement or approval of the use of such commercial products.

Table 3 (Continued)

Protection Method	Group (Sites)								
	1 (1)	2 (2,2A)	3 (3,4)	4 (5)	5 (6,7)	6 (8)	7 (9,10)	8 Brickyard	9 (11)
Broken Concrete Revetment									
Placed Revetment							X		X
Self-Forming Revetment									
Windrow									
Trench-Fill									
Other Revetment									
Used Auto Tire Mattress							X		
Sand-Cement Sack Revetment							X		
Interlocking Concrete Block		X				X	X		
Gabion (Vinyl-Coated Wire)		X	X		X	X	X		X

(Continued)

Table 3 (Continued)

Protection Method	Group (Sites)									
	1 (1)	2 (2,2A)	3 (3,4)	4 (5)	5 (6,7)	6 (8)	7 (9,10)	8 Brickyard	9 (11)	
<u>Bulkheads (w or w/o Toe Protection)</u>										
Used Auto Tires and Timber Post				X						
Gabions (Vinyl-Coated Wire)				X						
Treated Timber				X						
Steel Sheetpiling				X						
Steel H-Piles and Railroad Ties with Cap				X						
<u>Retard†</u>										
Used Auto Tire Post	X			X	X	X				

(Continued)

† Tiebacks (spurs connecting the retard structure to the bank) are recommended if the retard is not constructed directly against the toe of the existing bank.

Table 3 (Continued)

Protection Method	Group (Sites)								
	1 (1)	2 (2,2A)	3 (3,4)	4 (5)	5 (6,7)	6 (8)	7 (9,10)	8 Brickyard	9 (11)
<u>Longitudinal Dike (similar to rubble-mound seawall)</u> ††									
Riprap									
Broken Concrete									
<u>Beach Nourishment</u> ‡									
Maintenance Dredging									
Truck in Sand (Road Req'd)							X	X	
<u>Island Creation</u>									
Maintenance Dredging									

(Continued)

†† Tiebacks (spurs connecting the dike to the bank) are recommended if the dike is not constructed directly against the toe of the existing bank.

‡ Would require continued maintenance (could be destroyed by a rapid succession of severe storms). Could be used in combination with a perched beach.

Table 3 (Continued)

Protection Method	Group (Sites)								
	1 (1)	2 (2,2A)	3 (3,4)	4 (5)	5 (6,7)	6 (8)	7 (9,10)	8 Brickyard	9 (11)
Bank Failure Protection									
Slope Flattening (with Vegetation)									
Slope Benching (with Vegetation)									
Retaining Walls									
Concrete									
Mechanically Stabilized Soil									
Concrete Modular Units									

(Continued)

Table 3 (Continued)

Protection Method	Group (Sites)								
	1 (1)	2 (2,2A)	3 (3,4)	4 (5)	5 (6,7)	6 (8)	7 (9,10)	8 Brickyard	9 (11)
<u>Segmented Offshore Breakwater</u>									
Riprap									
Broken Concrete									
Sand-Cement Sack with Geotextile									
<u>Segmented Low-Crested Breakwater</u> ††									
Riprap			X						
Broken Concrete									
Sandbag									

(Continued)

†† Periodically overtopped.

Table 3 (Concluded)

Protection Method	Group (Sites)								
	1 (1)	2 (2,2A)	3 (3,4)	4 (5)	5 (6,7)	6 (8)	7 (9,10)	8 Brickyard	9 (11)
<u>Sill (Continuous Low-Crested Breakwater)## and Perched Beach</u>									
Riprap									
Broken Concrete									
Sandbag									
<u>Floating Breakwater</u>									
Floating Tire									
Tire-Pole									
Pole									
Concrete Box									

Periodically overtopped.

Table 4

Advantages and Disadvantages
of Types of Protection

1. Drainage Control - Diversion of Runoff at Top of Bank

Advantages. Reduces erosion at source; diversion to adjacent wetlands assists in sediment deposition and water quality treatment provided system not overloaded; prevents erosion during overtopping storm or excessive rainfall events.

Disadvantages. If improperly constructed and sited, results in increased erosion at site, adjacent wetlands and uplands.

2. Vegetation - Various

Advantages. No intertidal impacts or bottom impacts; creates wetland habitat for mitigation banking; increased fish habitat; increased sediment deposition and beach formation; increased nutrient uptake; self-maintaining.

Disadvantages. Experimental in moderate to high wave energy areas and must be used with other shoreline protection methods; sufficient time must be allowed for plantings to take hold; impacted by animals, i.e. beavers, geese, ducks, etc.

3. Geocomposite Mattresses - Various

Advantages. Biodegradable; temporary covering of intertidal zone; creates habitat for benthic organisms; increased sediment deposition; minimum impacts to shoreline access and recreation; may be used in combination with vegetation.

Disadvantages. Temporary requiring frequent re-installation and maintenance with subsequent habitat disturbance; experimental; restricted to soft sediments; subject to vandalism.

4. Revetments - Various

Advantages. No direct impacts to shallow bottom marine sediments and organisms by covering or suspended sediment impacts; creates reef-type fisheries and encrusting organism habitats in the intertidal zone; flexible revetments (riprap, broken concrete, used auto tire mattress, etc. will adjust to minor shifts in underlying bank material and is easily repaired; may be used with other methods such as vegetation.

(Continued)

Table 4 (Continued)

Disadvantages. Requires considerations of overtopping by waves and storm events; requires flanking considerations; shaping and sloping of bank required for installation; rely on bank for support, and therefore, must follow an existing bankline; rigid revetments, such as sand-cement sack revetment are impervious and provide no relief of excess ground water pressure nor can they accommodate differential movements; interlocking (non cable-stayed) concrete block systems gain their strength from the protection from undercutting that each block provides its neighbors - if one block is lost, the entire revetment can unravel; reduction of beach access and recreation.

5. Bulkheads - Various

Advantages. Few direct impacts to intertidal and bottom dwelling organisms; provides access to bank for small boats; may be used in combination with other methods.

Disadvantages. Decreased beach access and use for recreation; overtopping and flanking impacts to adjacent wetlands and uplands; increased toe scour; treated timbers and poles with contaminants; excessive site preparation; upland losses; backfill requirements.

6. Retards - Auto Tire Post - Various

Advantages. Few impacts to intertidal and bottom-dwelling organisms; may be oriented to obtain a desired bank alignment; the sediment deposition caused by the retard structure can create an environment acceptable to the volunteering of vegetation.

Disadvantages. Restricted access to beach for recreation; unsightly; foreign material use for construction; navigation hazard; have a history of being outflanked if a smooth transition from retard structure to bank is not provided at the upstream and downstream terminus of the structure.

7. Longitudinal Dike

Advantages. Permanent nature; easily constructed along irregularly eroding banks; increased fisheries and encrusting organism habitat; increased sediment deposition in breakwater area.

(Continued)

Table 4 (Concluded)

Disadvantages. Direct and indirect burial; restricted access to beach for recreation; navigation hazard.

8. Beach Nourishment

Advantages. Availability of like-kind fill materials readily available; new habitat created for bottom-dwelling and fisheries organisms; beneficial use of dredged material; may be used with vegetation.

Disadvantages. Temporary nature; impacts to intertidal and bottom dwelling organisms; experimental in moderate to high wave energy areas; increased permitting and mitigation requirements.

9. Island Creation

Advantages. Creates new open-water, wetland and upland habitats for fish and wildlife; long-term wave abatement solution; provide relatively predator-free wildlife habitat areas, such as nesting areas for shore birds.

Disadvantages. Experimental; impacts to bottom dwelling organisms; navigation hazard; interference with water quality, i.e. circulation; wave refraction to adjacent areas; permanent.

10. Breakwater - Emergent and Submerged - Permanent

Advantages. Permanent nature; increased fisheries and encrusting organism habitat; increased sediment deposition in breakwater area.

Disadvantages. Direct and indirect burial impacts to bottom-dwelling organisms; navigation hazard; water circulation impacts; increased mitigation requirements.

11. Breakwater - Floating Offshore - Temporary

Advantages. Sediment deposition behind structure assisting in beach formation; no suspended solids or fill impacts to bottom dwelling organisms; may be used with other methods such as vegetation; natural materials may be used, i.e. logs, timbers, etc.; highly valued for fish attractant structures.

Disadvantages. May fail in high energy, high magnitude storm events; subject to icing effects and burial by sediments; subject to vandalism; navigation hazard, contamination If new creosoted or treated lumber or poles are used; temporary and require maintenance.

Table 5

Protection Methods Selected for Group 1 (Site 1)

<u>Protection Method*</u>	<u>Environmental Problems</u>	<u>Relative Cost</u>	<u>Ranking</u>
<u>Used Auto Tire Post Retard</u>	Medium	Low	1
<u>Placed Revetment</u>			
a. Graded Riprap	Low	High	2
<u>Other Revetment</u>			
a. Gabion (Vinyl-Coated Wire)	High	High	3

* Drainage Control (diversion of runoff at top of bank) should be used in conjunction with whatever protection method is selected.

Table 6

Protection Methods Selected for Group 2 (Sites 2, 2A)

<u>Protection Method</u>	<u>Environmental Problems</u>	<u>Relative Cost</u>	<u>Ranking</u>
<u>Placed Revetment and Vegetation on Upper 1 ft Above MHT</u>			
a. Graded Riprap	Low	Low	1
<u>Other Revetment</u>			
a. Interlocking Concrete Block	Low	Medium	2
b. Gabion (Vinyl-Coated Wire)	Low	High	3

Table 7

Protection Methods Selected for Group 3 (Sites 3, 4)

<u>Protection Method</u>	<u>Environmental Problems</u>	<u>Relative Cost</u>	<u>Ranking</u>
<u>Placed Revetment and Vegetation on Upper 1 ft Above MHT</u>			
a. Graded Riprap	Low	Medium	1
<u>Segmented Low-Crested Breakwater</u>			
a. Graded Riprap	High	High	2
<u>Other Revetment</u>			
a. Gabion (Vinyl-Coated Wire)	Low	High	3

Table 8

Protection Methods Selected for Group 4 (Site 5)

<u>Protection Method*</u>	<u>Environmental Problems</u>	<u>Relative Cost</u>	<u>Ranking</u>
<u>Placed Revetment and Vegetation on 1 ft Wide Strip Above MHT</u>			
a. Graded Riprap	Low	Medium	1
<u>Used Auto Tire Post Retard</u>			
	Medium	Low	2
<u>Bulkheads with Toe Protection and Vegetation Behind Bulkhead</u>			
	High	High	3
a. Used Auto Tires and Timber Post			
b. Gabions (Vinyl-Coated Wire)			
c. Treated Timber			
d. Steel Sheetpiling			
e. Steel H-Piles and Railroad Ties with Cap			

* Drainage Control (diversion of runoff at top of bank) should be used in conjunction with whatever protection method is selected.

Table 9

Protection Methods Selected for Group 5 (Sites 6, 7)

<u>Protection Method</u>	<u>Environmental Problems</u>	<u>Relative Cost</u>	<u>Ranking</u>
<u>Placed Revetment</u>			
a. Graded Riprap	Low	Low	1
<u>Used Auto Tire Post Retard</u>	Medium	Low	2
<u>Other Revetment</u>			
a. Gabion (Vinyl-Coated Wire)	Low	High	3

Table 10

Protection Methods Selected for Group 6 (Site 8)

<u>Protection Method</u>	<u>Environmental Problems</u>	<u>Relative Cost</u>	<u>Ranking</u>
<u>Placed Revetment</u>			
a. Graded Riprap	Low	Low	1
<u>Used Auto Tire Post Retard</u>	Low	Low	2
<u>Other Revetment</u>			
a. Interlocking Concrete Block			
b. Gabion (Vinyl-Coated Wire)	Low	High	3

Table 11

Protection Methods Selected for Group 7 (Sites 9, 10)

<u>Protection Method</u>	<u>Environmental Problems</u>	<u>Relative Cost</u>	<u>Ranking</u>
<u>Geocomposite Mattress and Vegetation of Upper 2/3 of Intertidal Zone (Grade bank to stable slope)</u>	Low	Low	1
a. Biodegradable			
1. HoldGro			
2. Geojute			
3. Ero-Mat			
4. Excelsior Blanket			
b. Non-Biodegradable			
1. Enkamat			
2. Miramat			
3. Tensarmat			
<u>Beach Nourishment and Vegetation of Upper 2/3 of Intertidal Zone (Would have to be replenished periodically)</u>			
a. Truck in Sand (Road required)	Medium	Medium	2
<u>Placed Revetment and Vegetation on Upper 1 ft Above MHT (Grade bank to stable slope)</u>	High	Medium	3
a. Graded Riprap			
b. Broken Concrete			

(Continued)

Table 11 (Concluded)

Protection Methods Selected for Group 7 (Sites 9, 10)

<u>Protection Method</u>	<u>Environmental Problems</u>	<u>Relative Cost</u>	<u>Ranking</u>
<u>Other Revetment and Vegetation on Upper 1 ft Above MHT (Grade bank to stable slope)</u>	High	Medium	4
a. Used Auto Tire Mattress			
b. Sand-Cement Sack Revetment			
c. Interlocking Concrete Block			
d. Gabion (Vinyl-Coated Wire)			

Table 12

Protection Methods Selected for Group 8 (Brickyard)

<u>Protection Method</u>	<u>Environmental Problems</u>	<u>Relative Cost</u>	<u>Ranking</u>
<u>Regulation of Boat Traffic</u>	Low	Low	1
a. Boat Speed and/or Horsepower			
b. Off-Limit Zones			
<u>Vegetation</u>			
a. Upper 2/3 of intertidal Zone (ML to MH Tide)	Medium	Medium	2
<u>Beach Nourishment and Vegetation of Upper 2/3 of Intertidal Zone (Would have to be replenished periodically)</u>			
a. Truck in Sand (Road Required)	High	High	3

Table 13

Protection Methods Selected for Group 9 (Site 11)

<u>Protection Method*</u>	<u>Environmental Problems</u>	<u>Relative Cost</u>	<u>Ranking</u>
<u>Vegetation</u>			
a. Upper 2/3 of intertidal Zone (ML to MH Tide)	Low	Low	1
<u>Placed Revetment and Vegetation on Upper 2/3 of Intertidal Zone</u>			
a. Graded Riprap			
b. Broken Concrete			
<u>Other Revetment and Vegetation on Upper 1 ft Above MHT</u>			
a. Gabion (Vinyl-Coated Wire)	High	High	3

* Drainage Control (diversion of runoff at top of bank) should be used in conjunction with whatever protection method is selected.

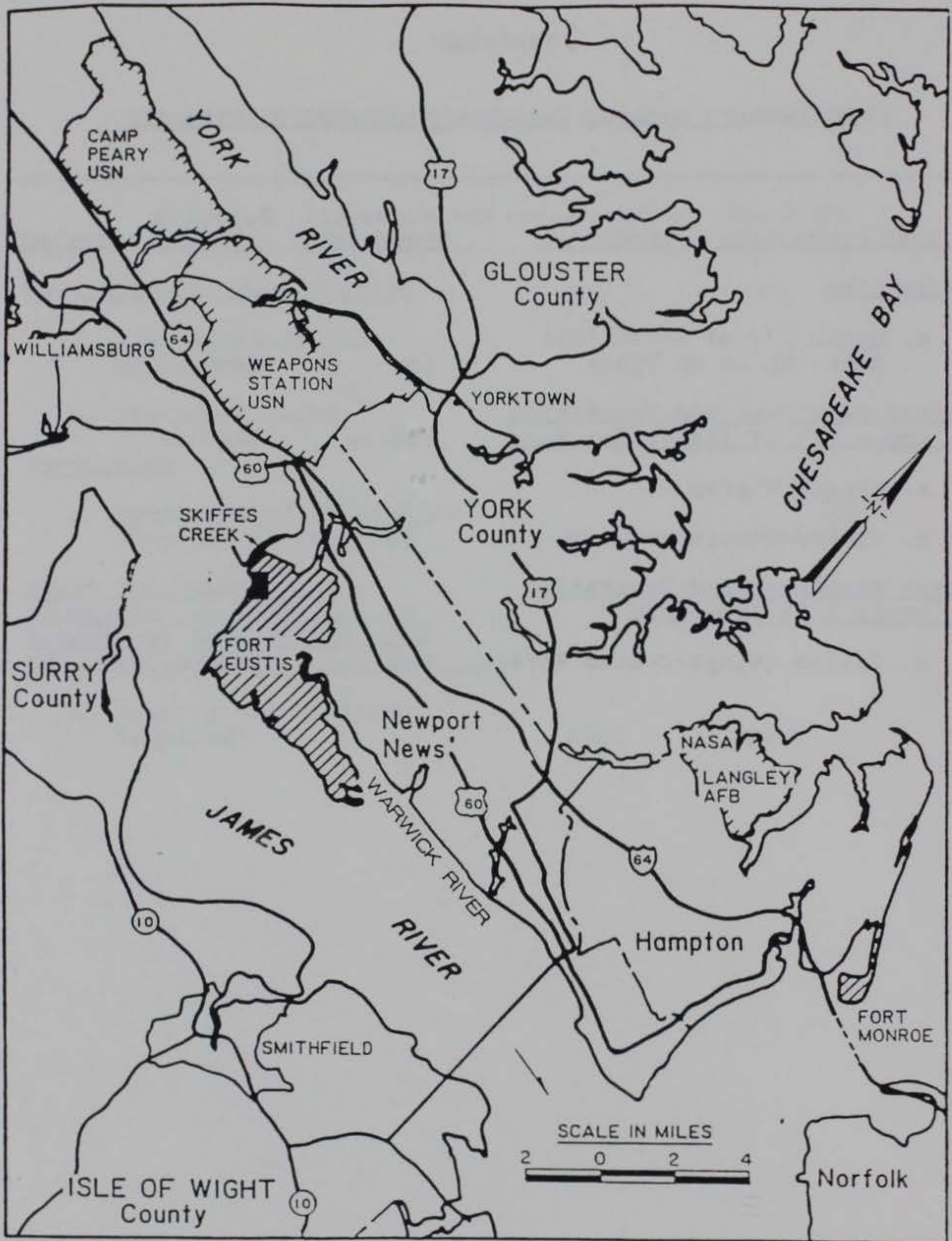

FIGURE 1. VICINITY MAP OF FORT EUSTIS, VA.

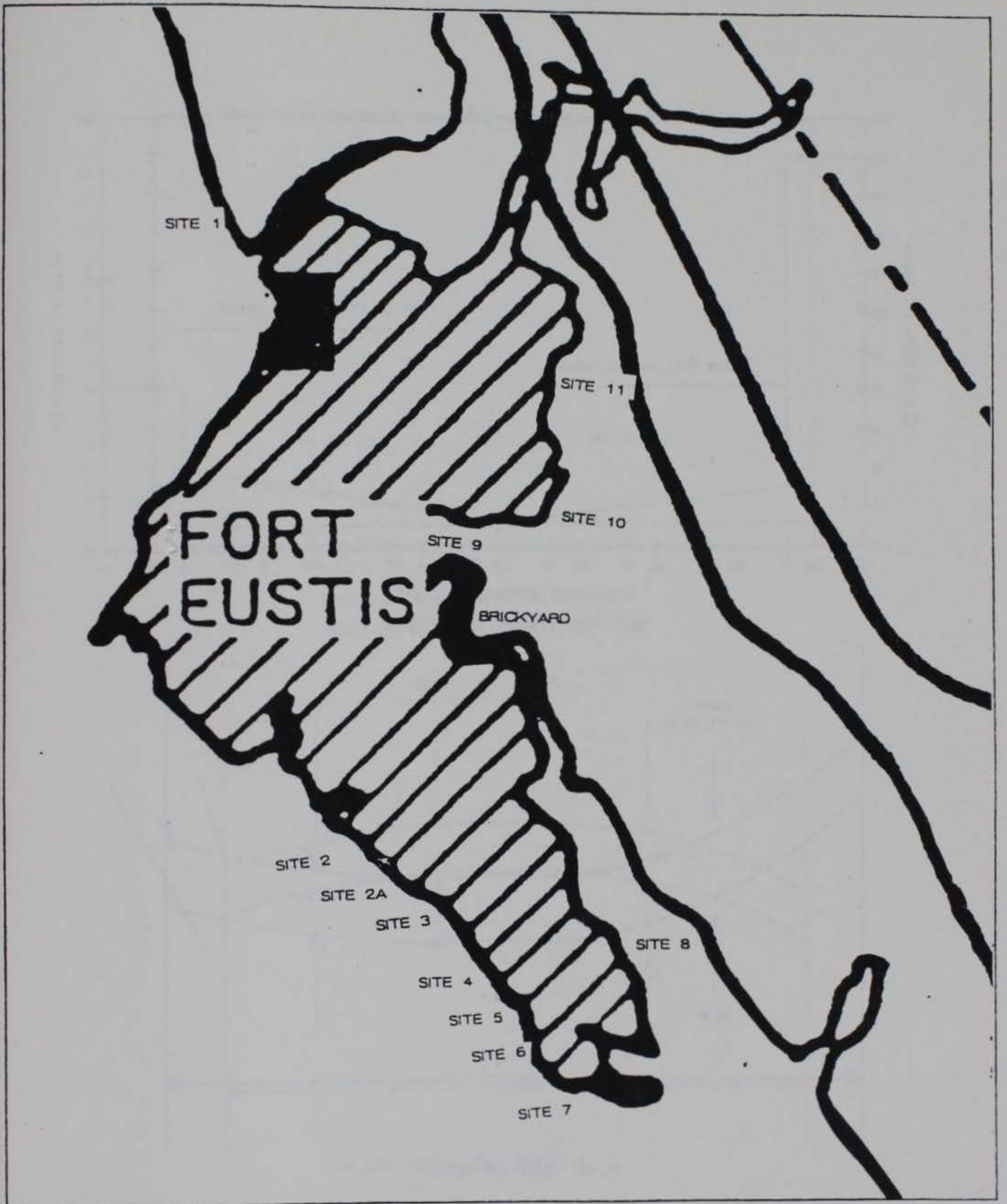

FIGURE 2. LOCATION OF ERODED SITES

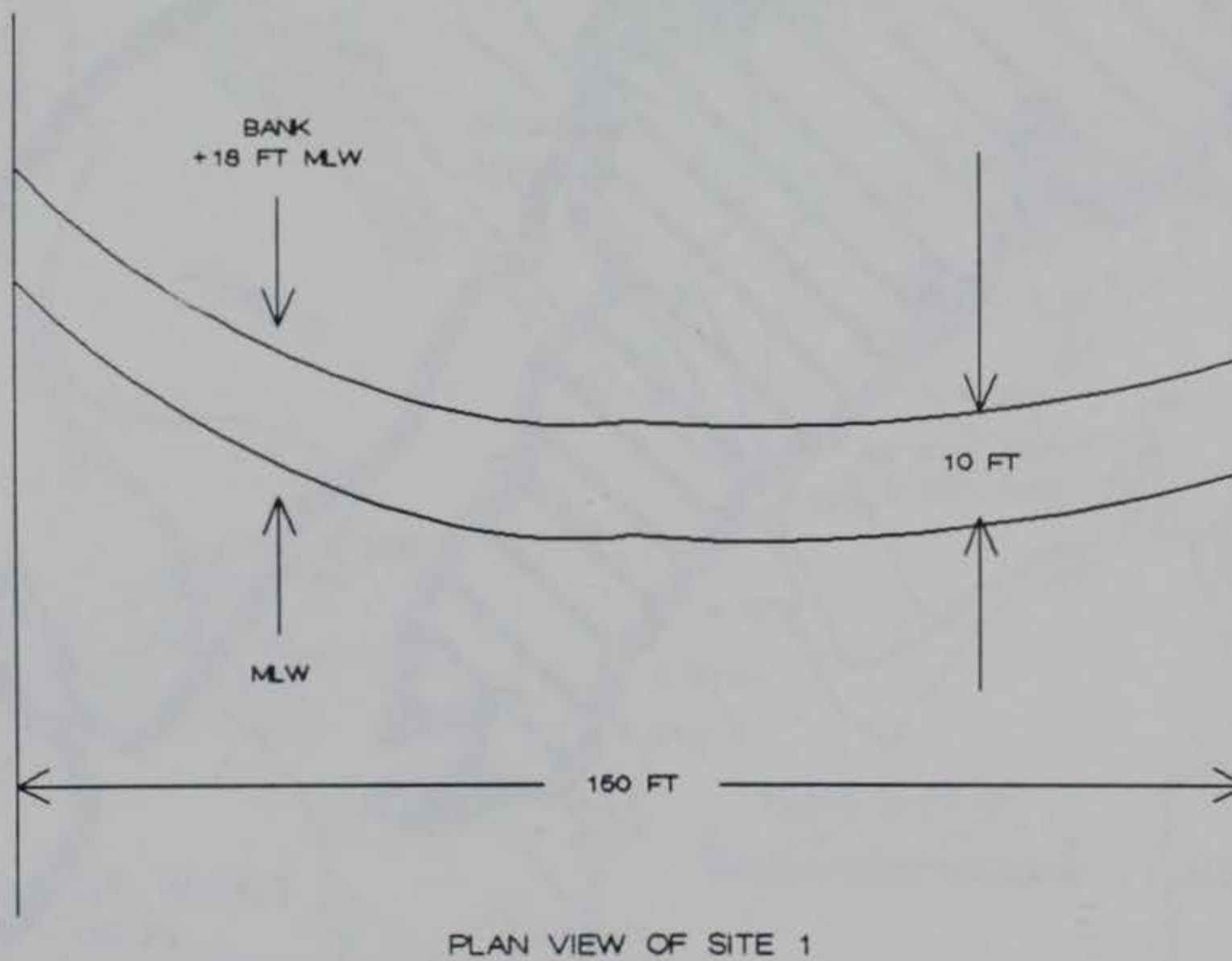
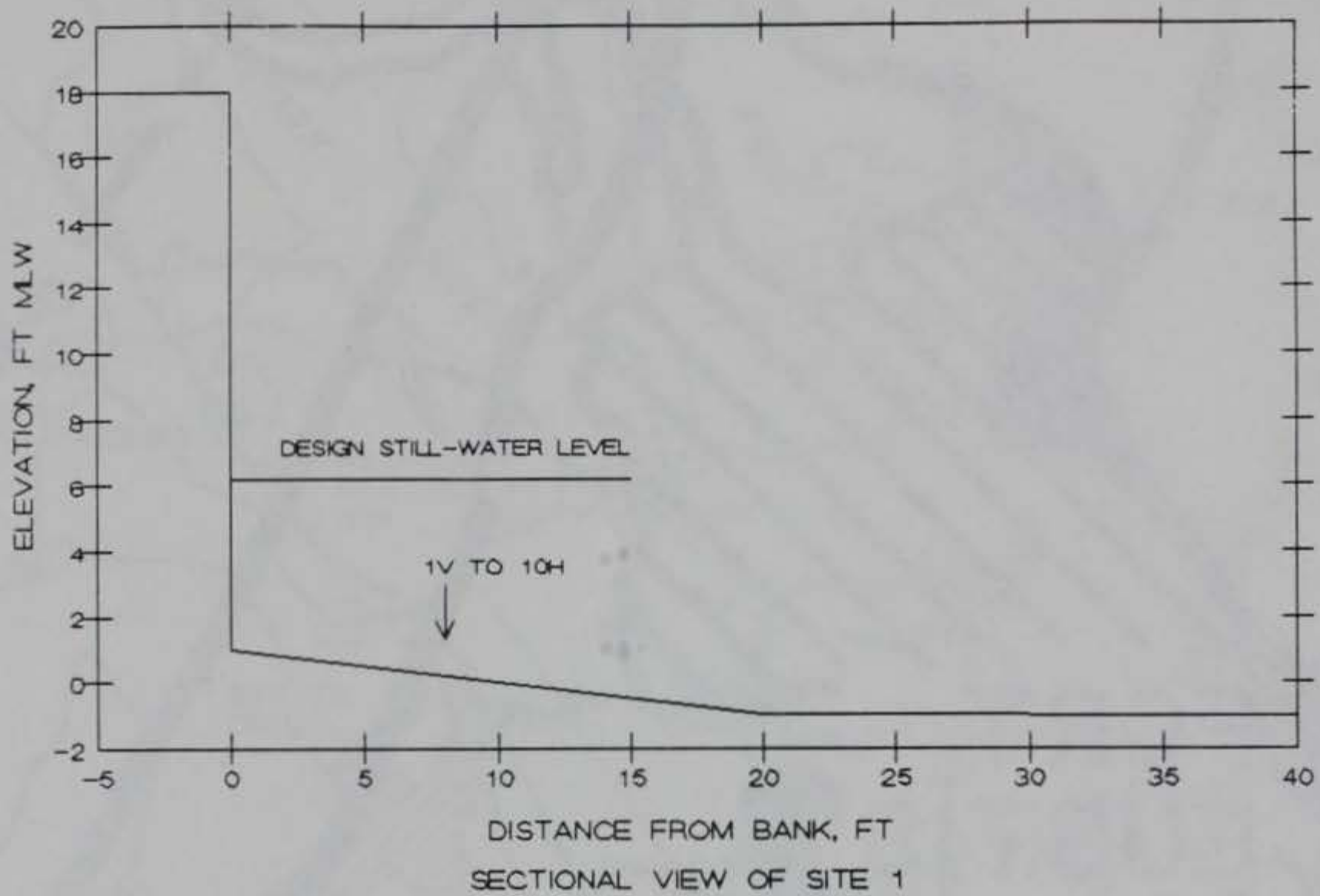

FIGURE 3. SECTIONAL AND PLAN VIEWS OF SITE 1

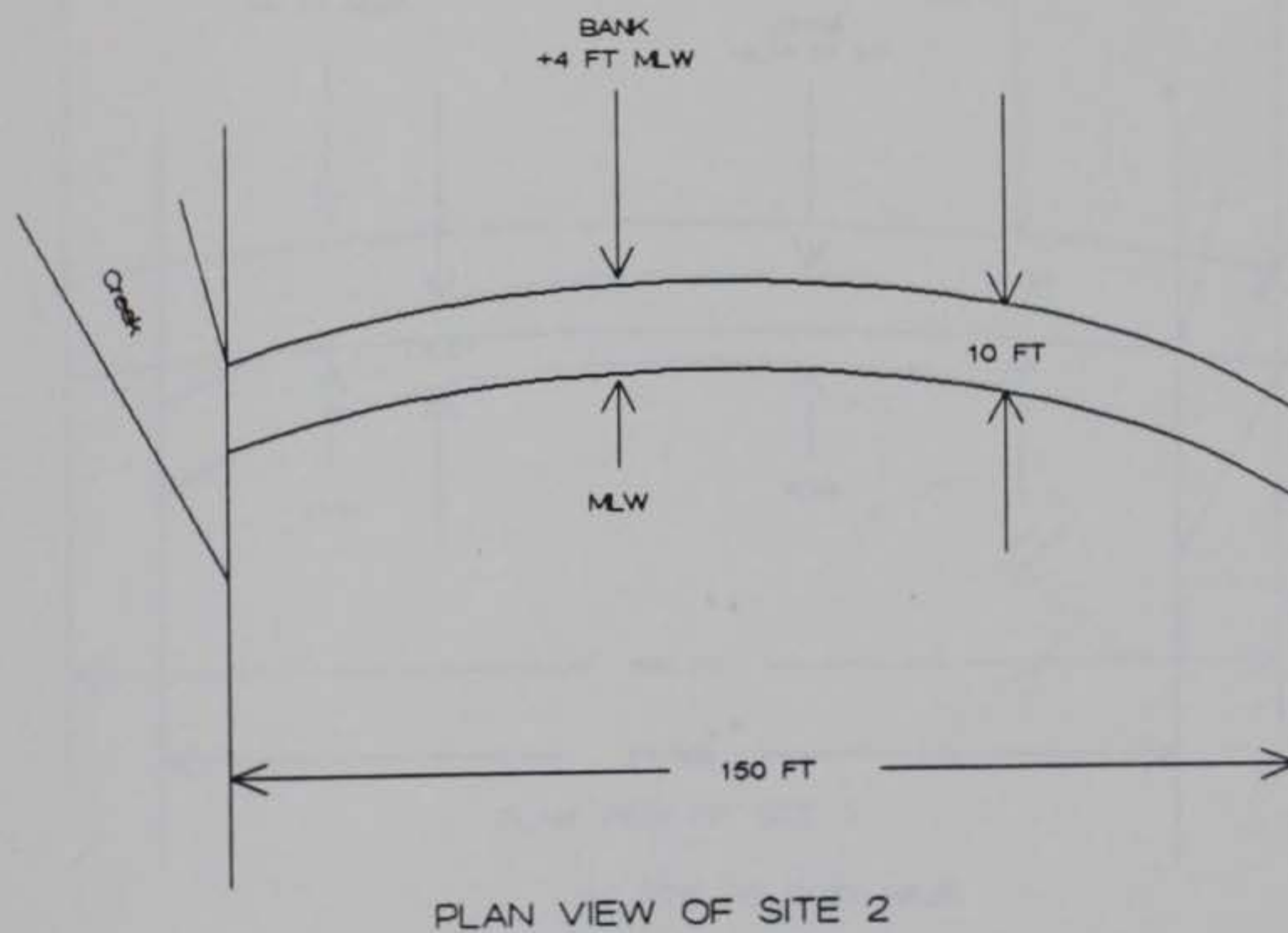
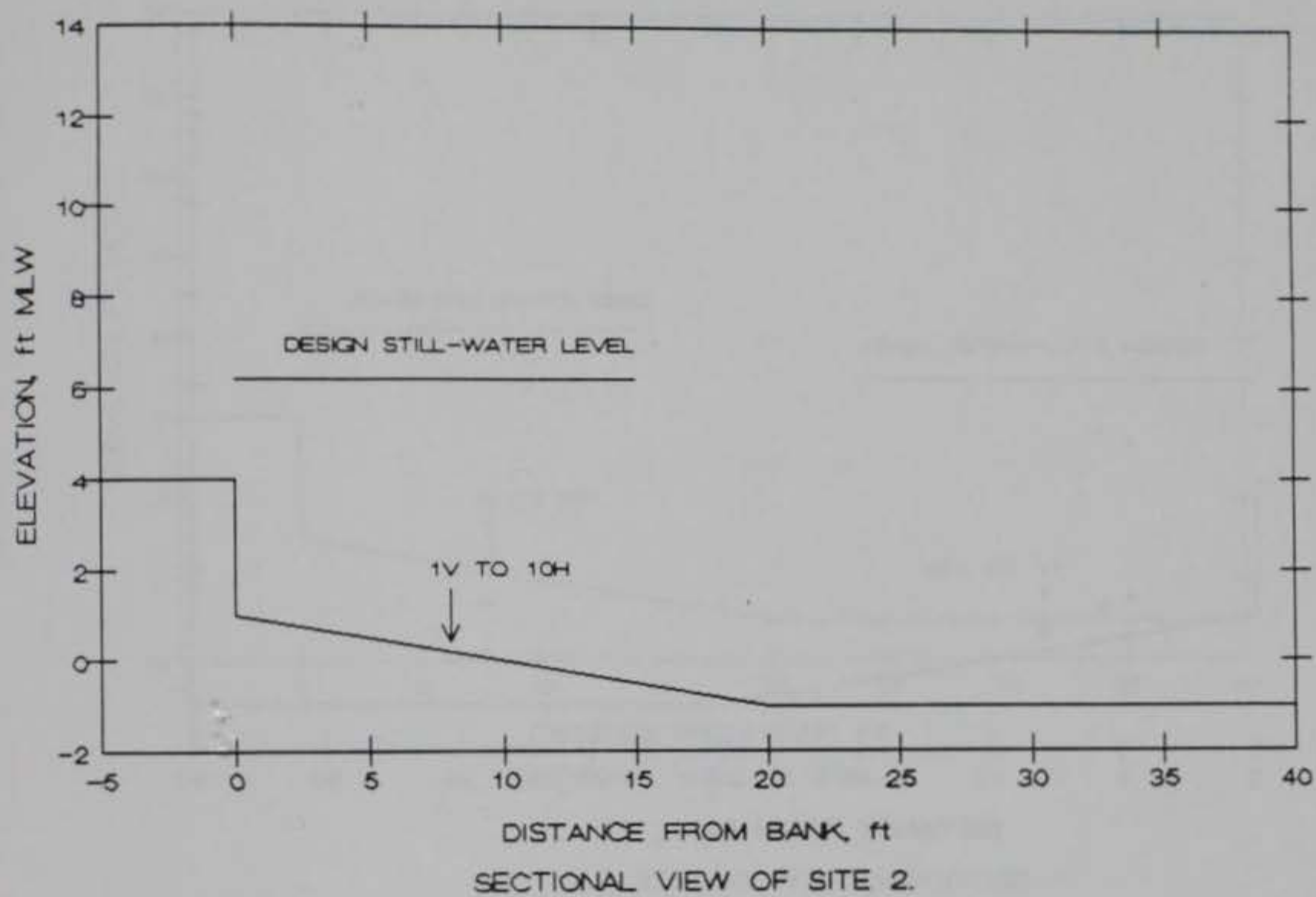

FIGURE 4. SECTIONAL AND PLAN VIEWS OF SITE 2

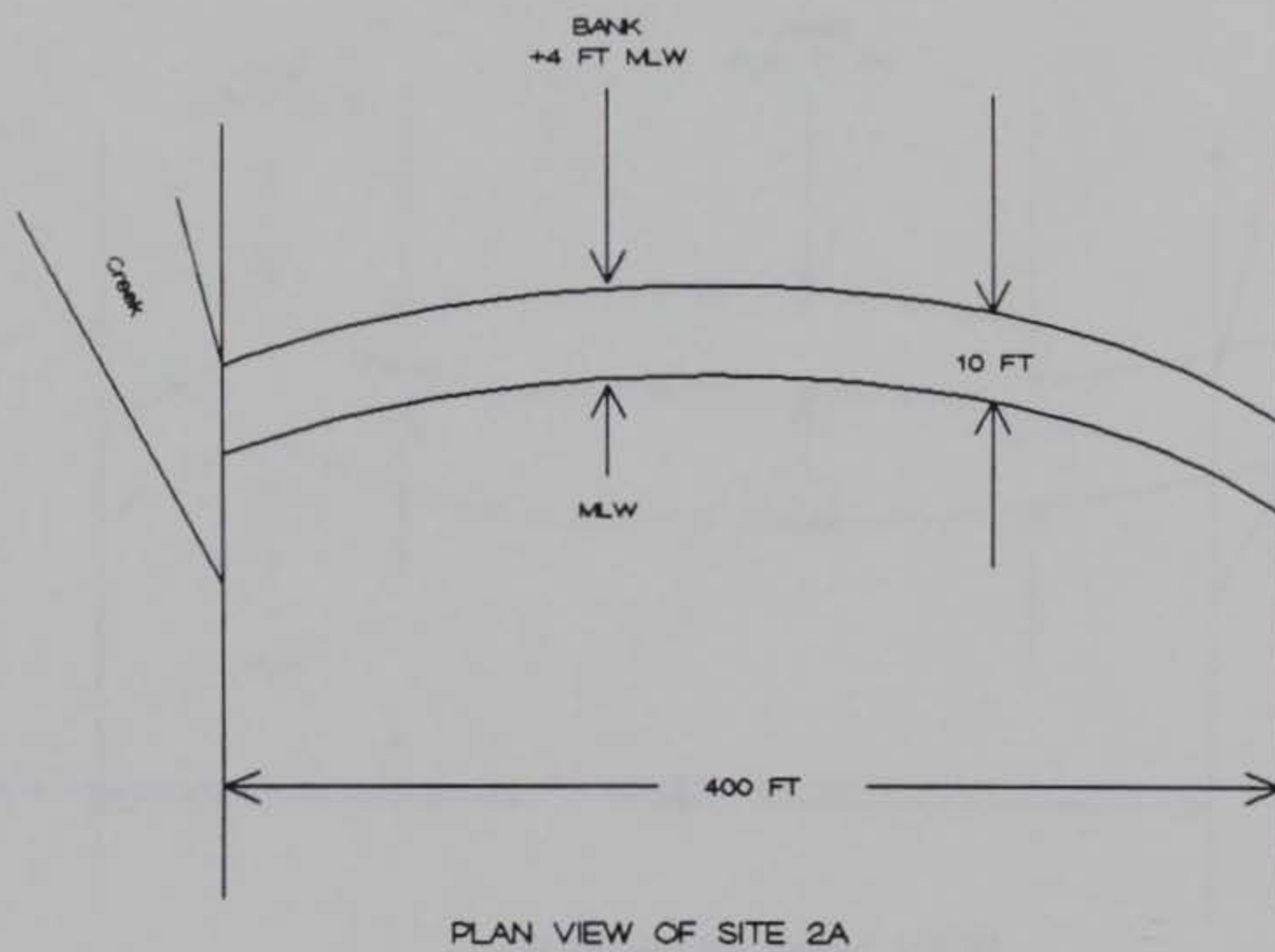
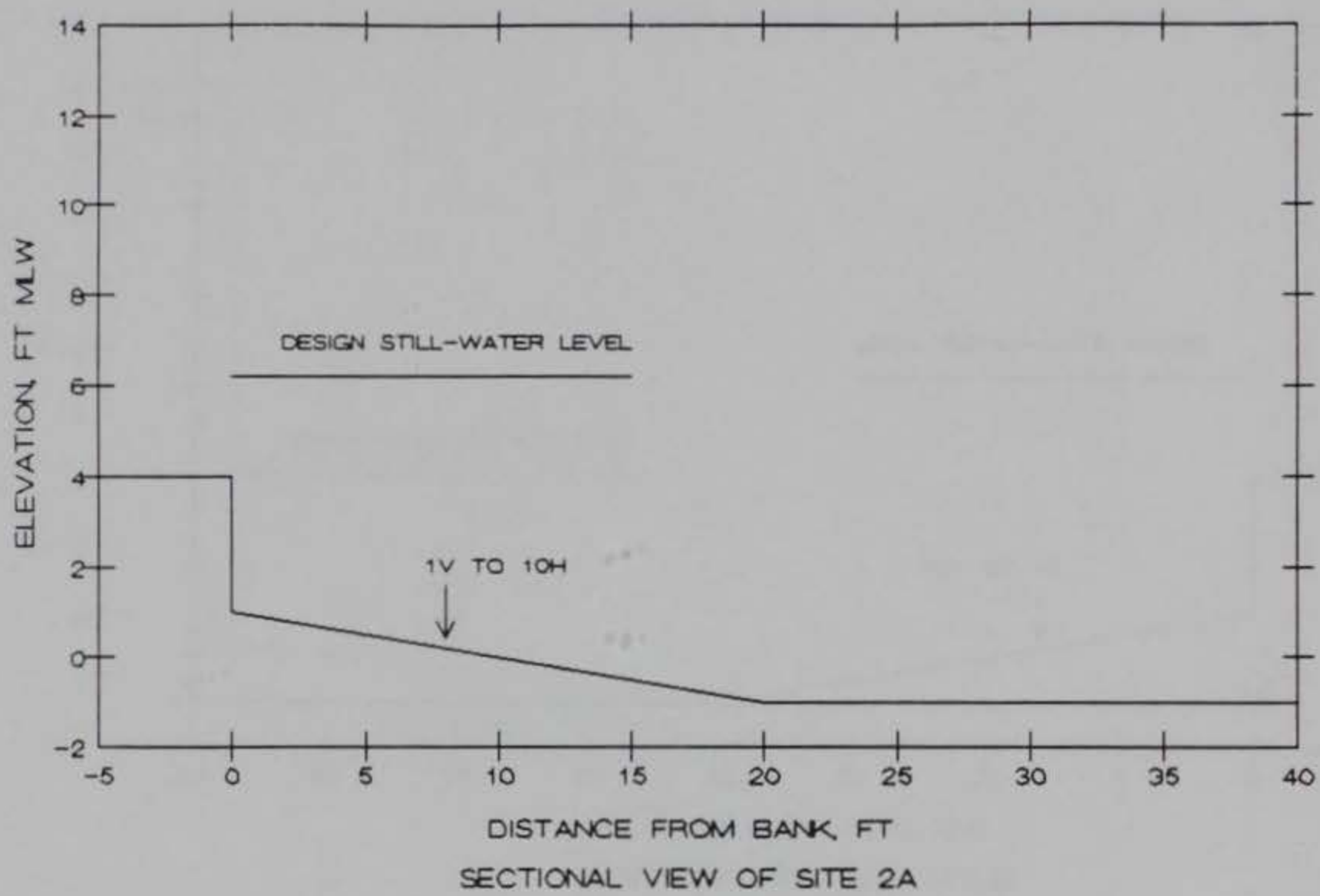

FIGURE 5. SECTIONAL AND PLAN VIEWS OF SITE 2A

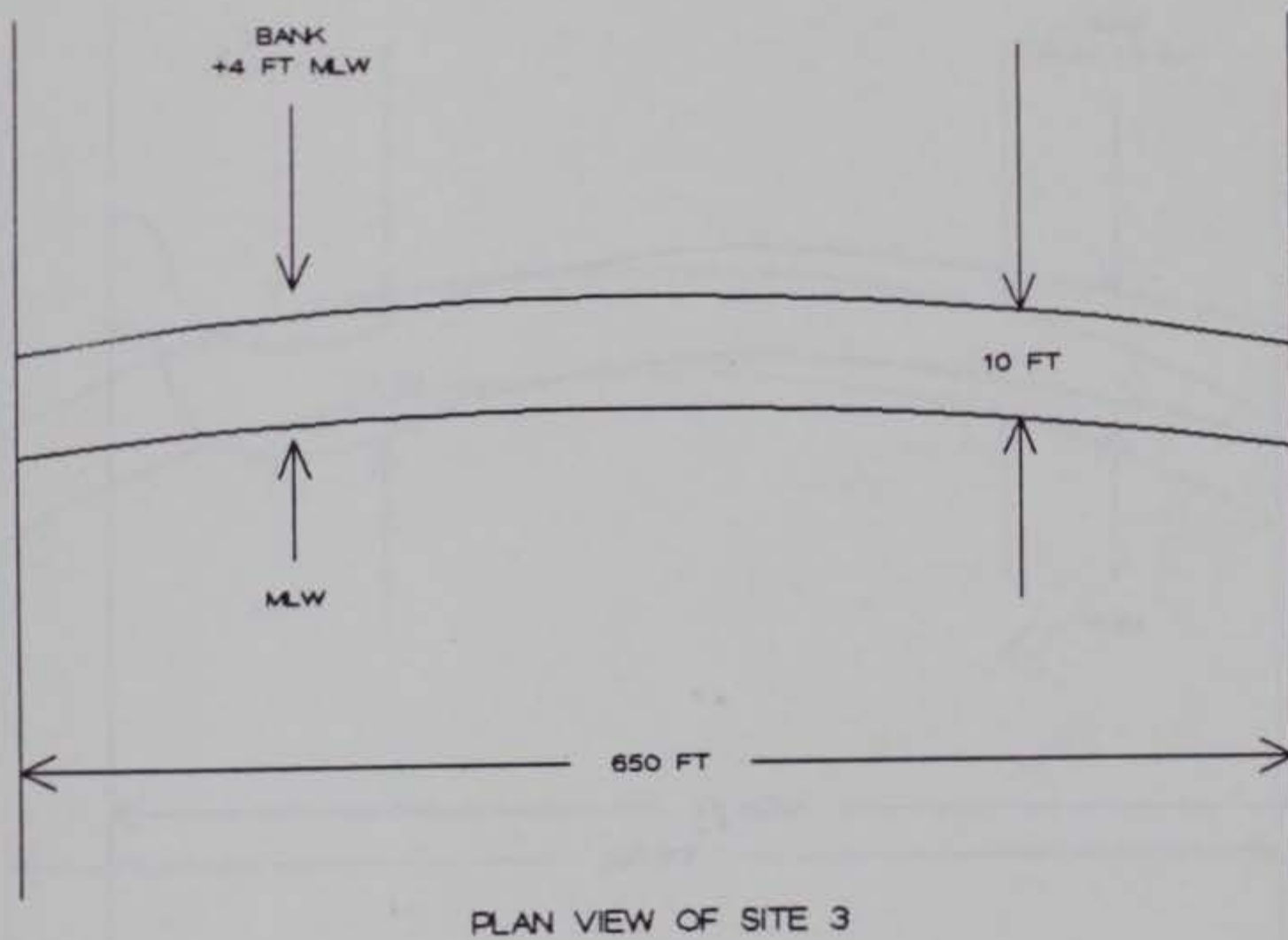
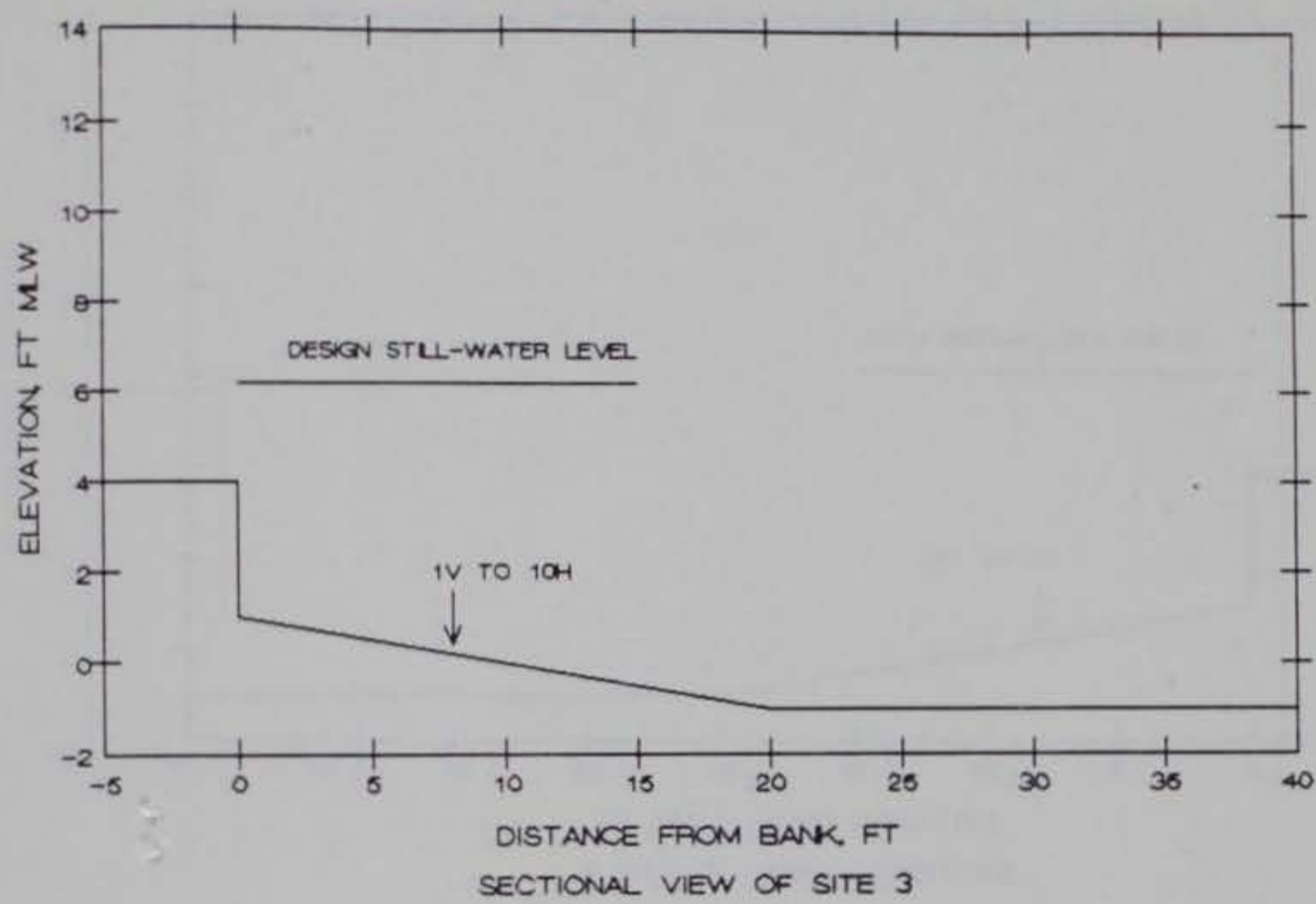

FIGURE 6. SECTIONAL AND PLAN VIEWS OF SITE 3

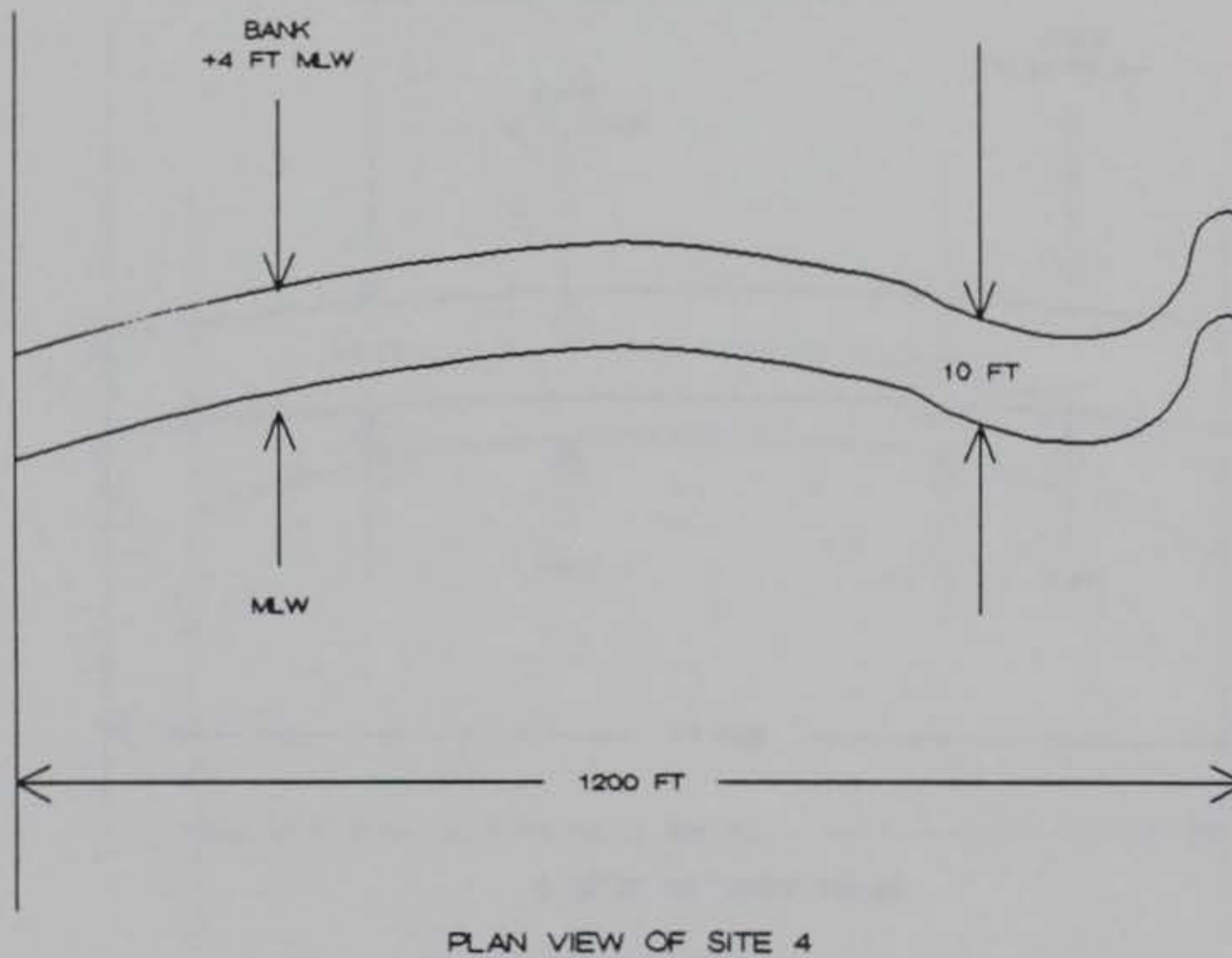
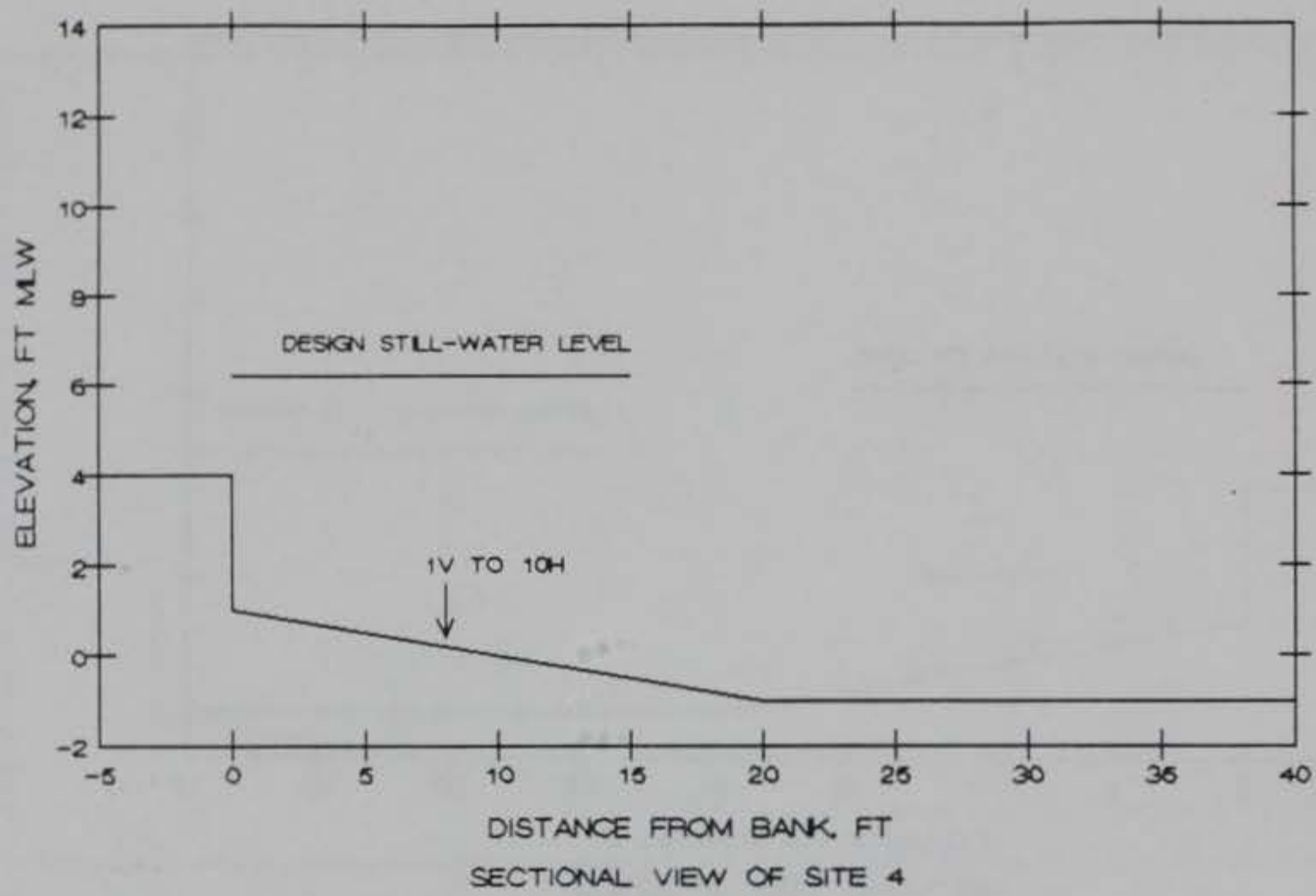

FIGURE 7. SECTIONAL AND PLAN VIEWS OF SITE 4

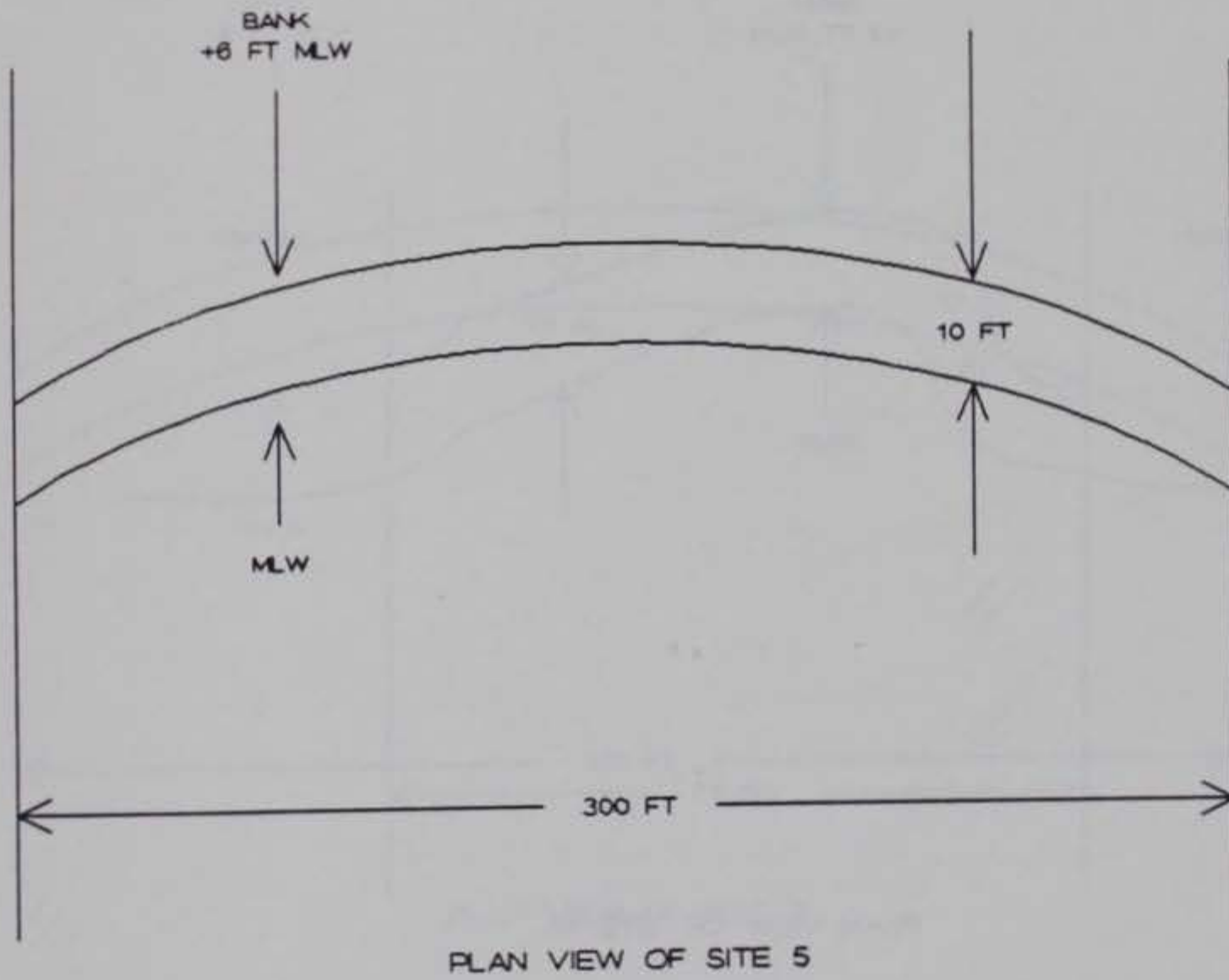
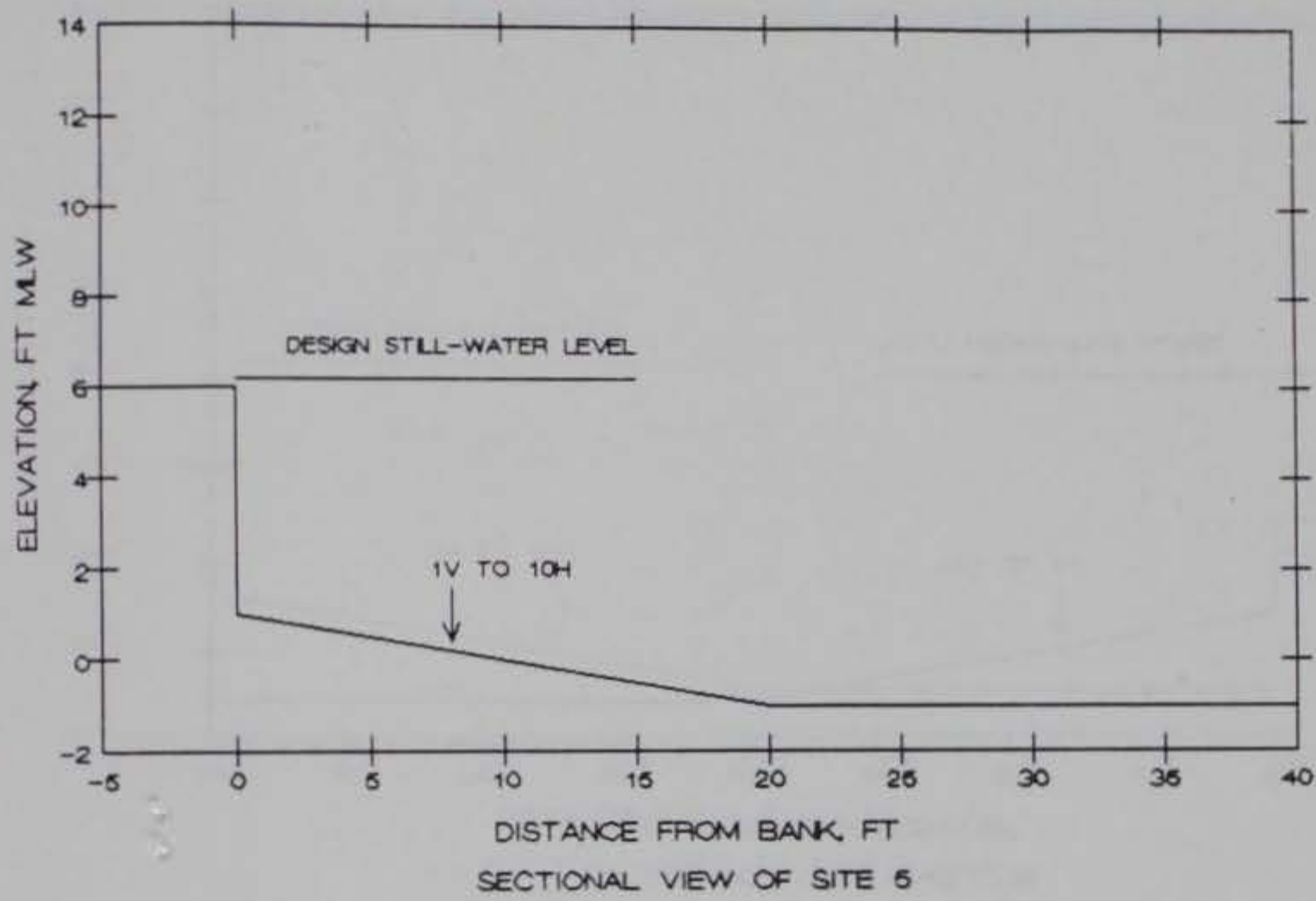

FIGURE 8. SECTIONAL AND PLAN VIEWS OF SITE 5

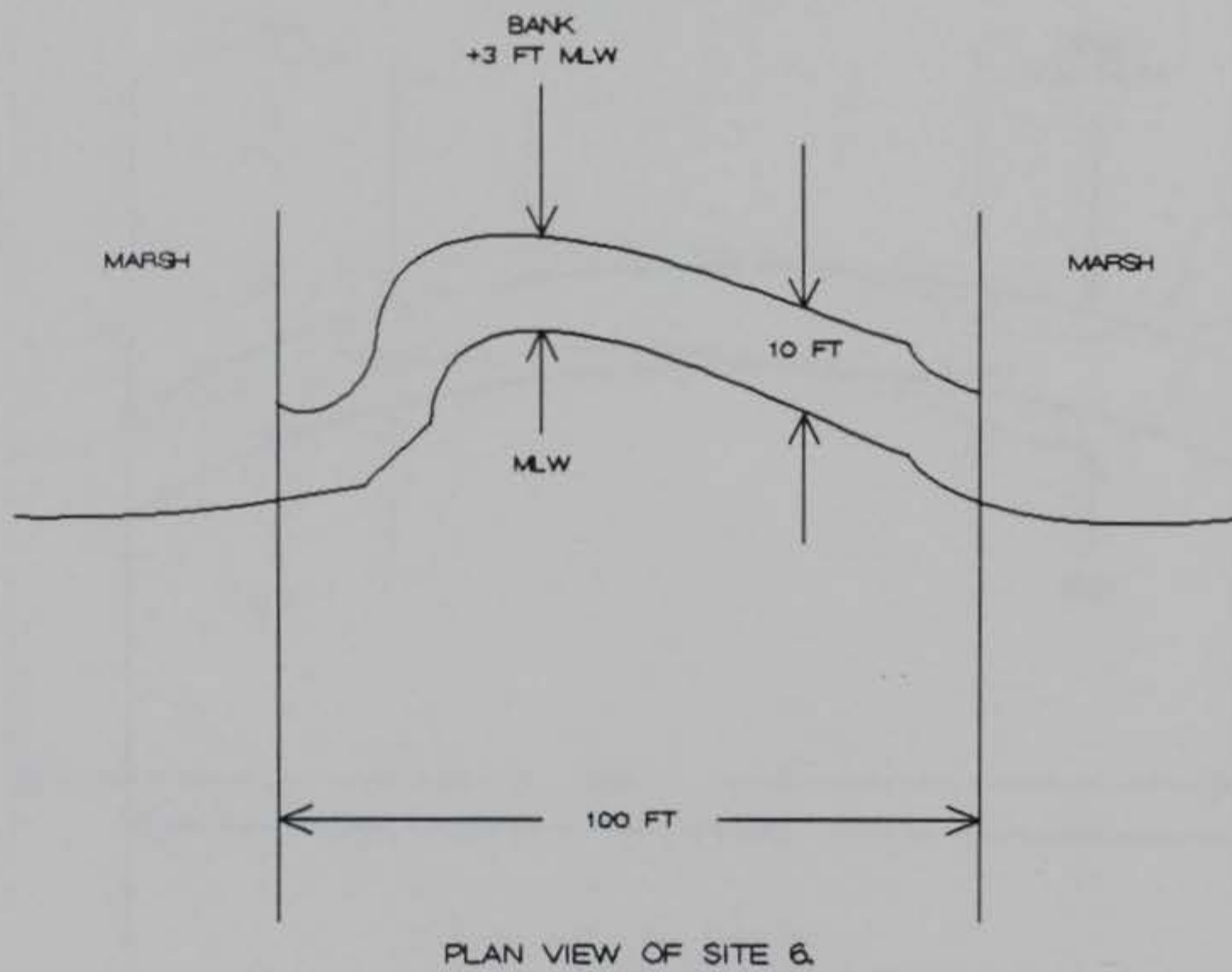
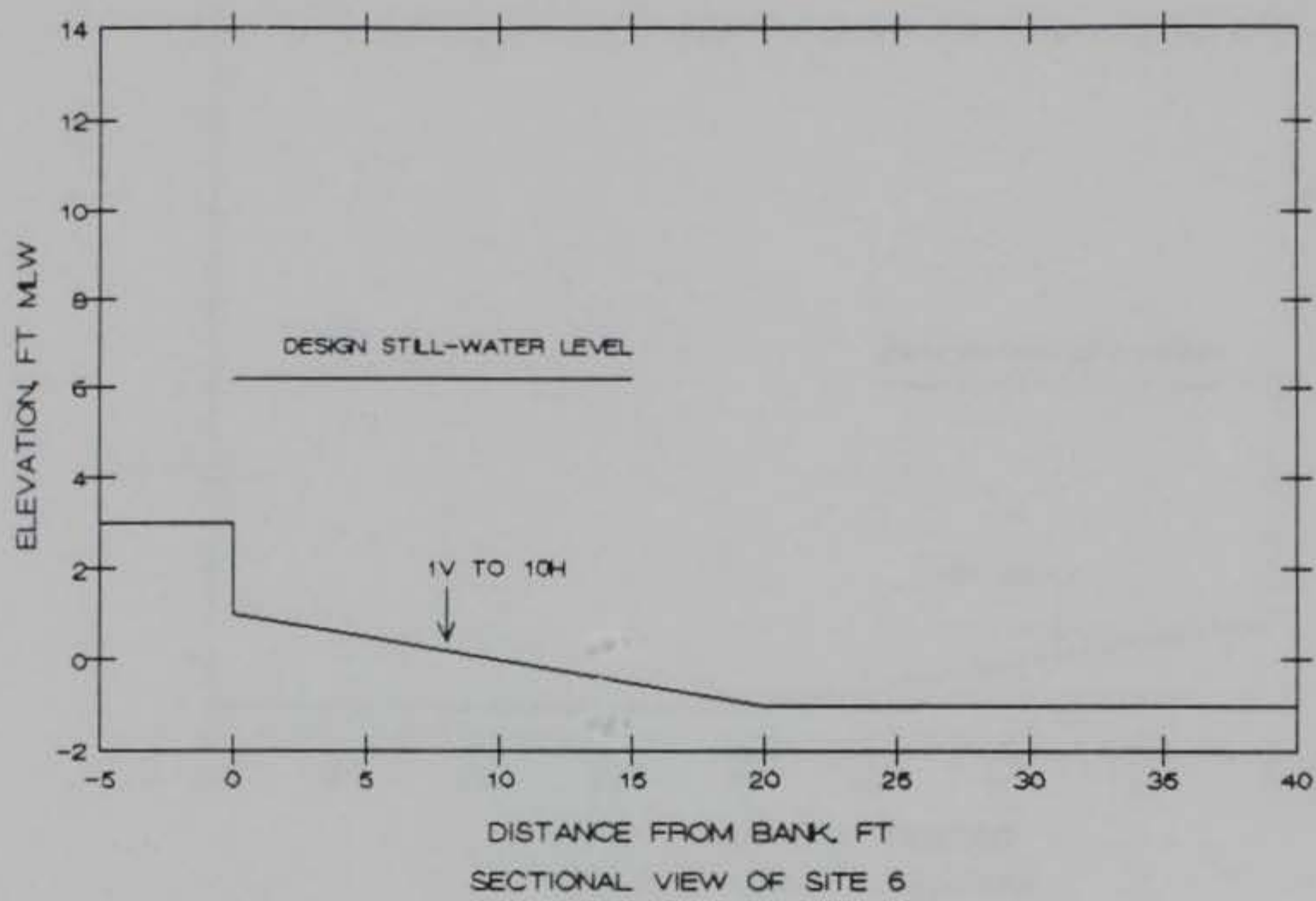

FIGURE 9. SECTIONAL AND PLAN VIEWS OF SITE 6

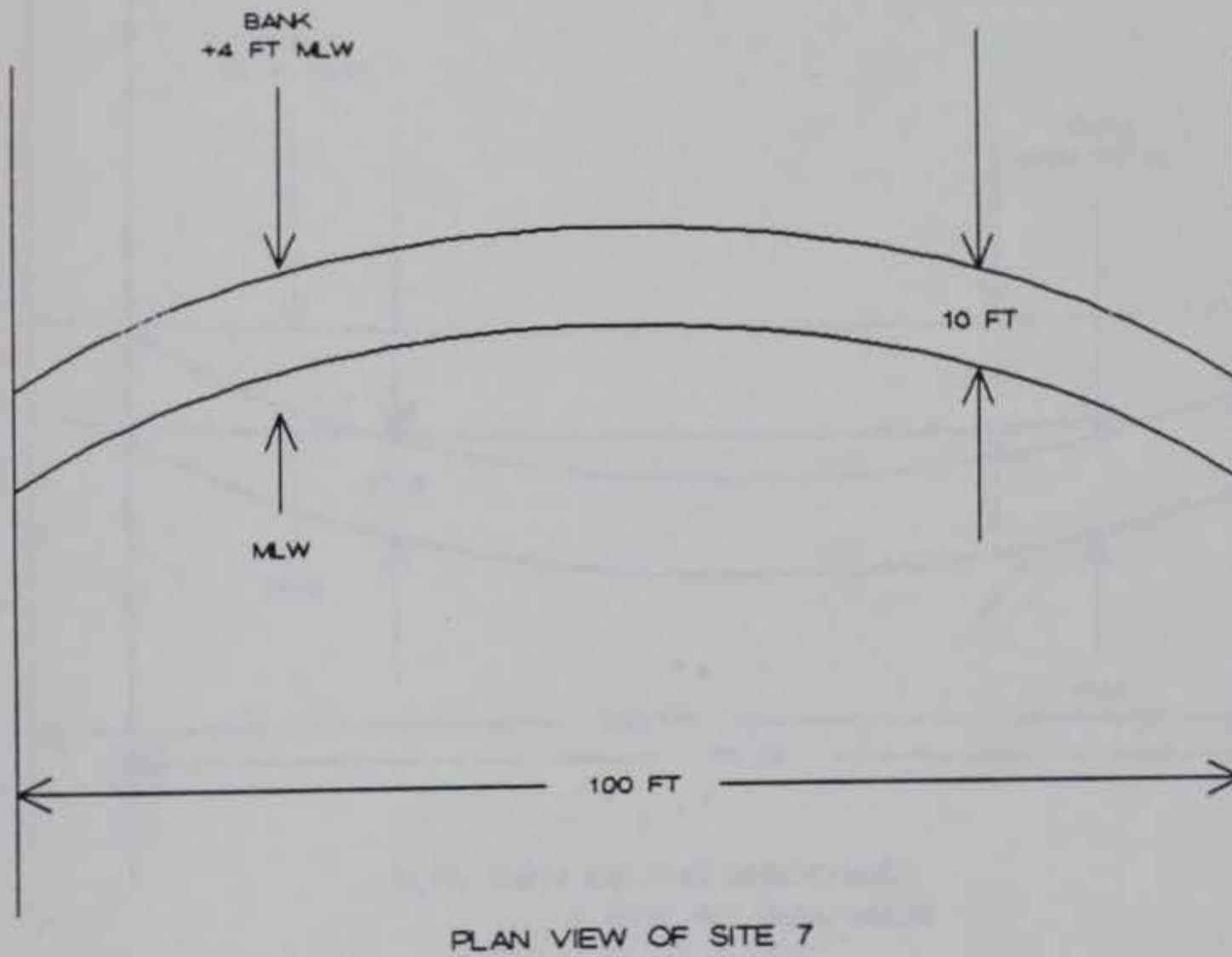
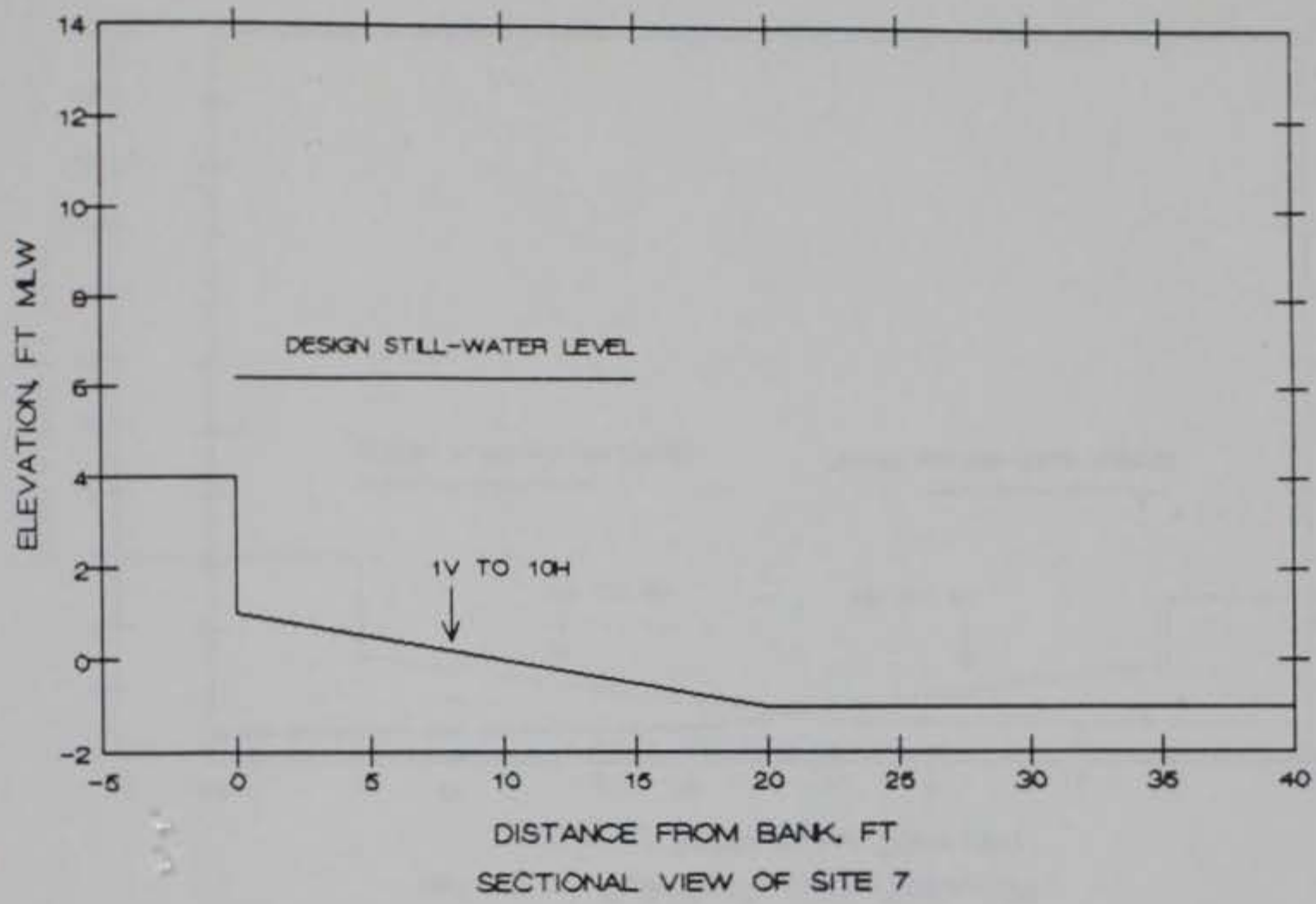

FIGURE 10. SECTIONAL AND PLAN VIEWS OF SITE 7

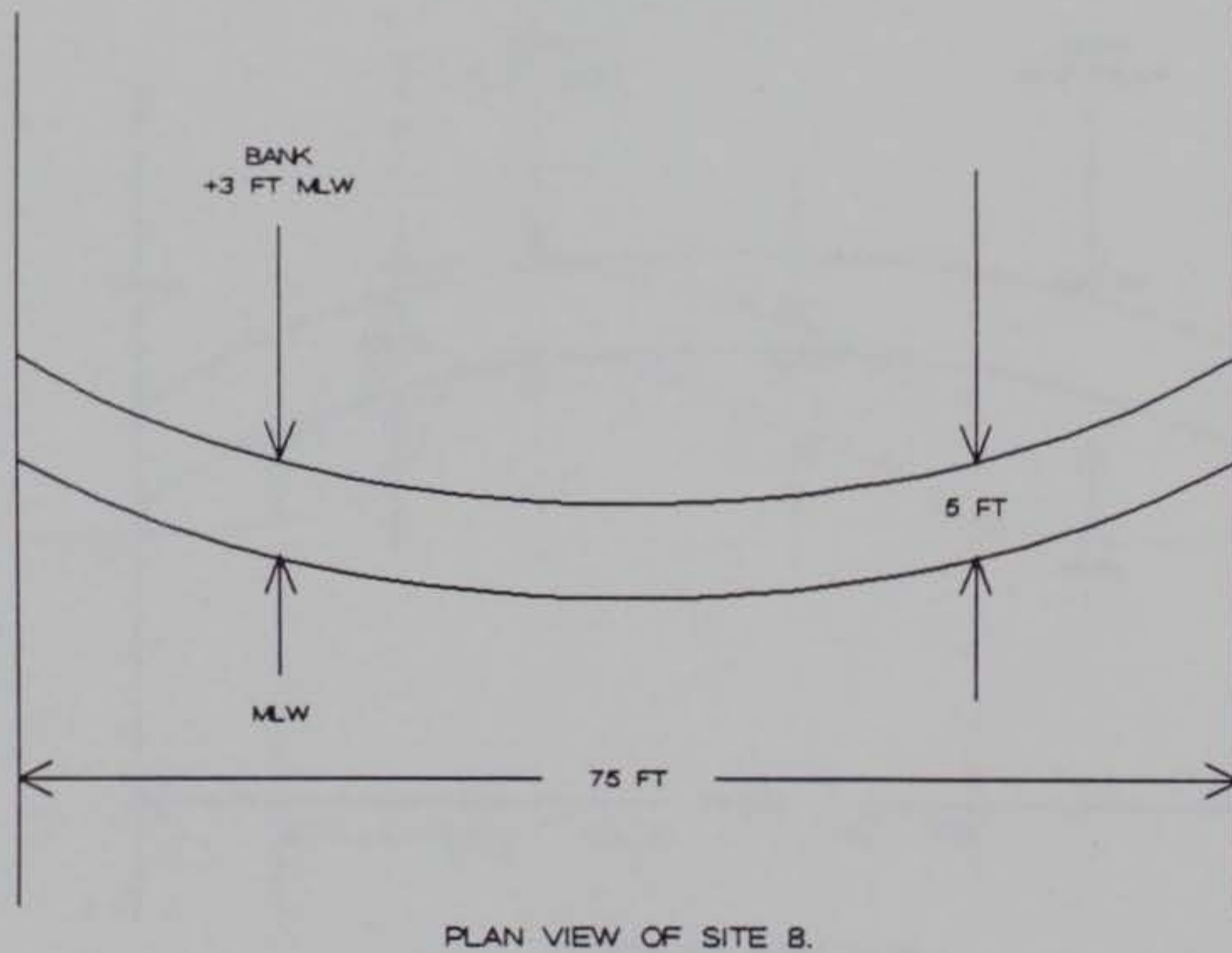
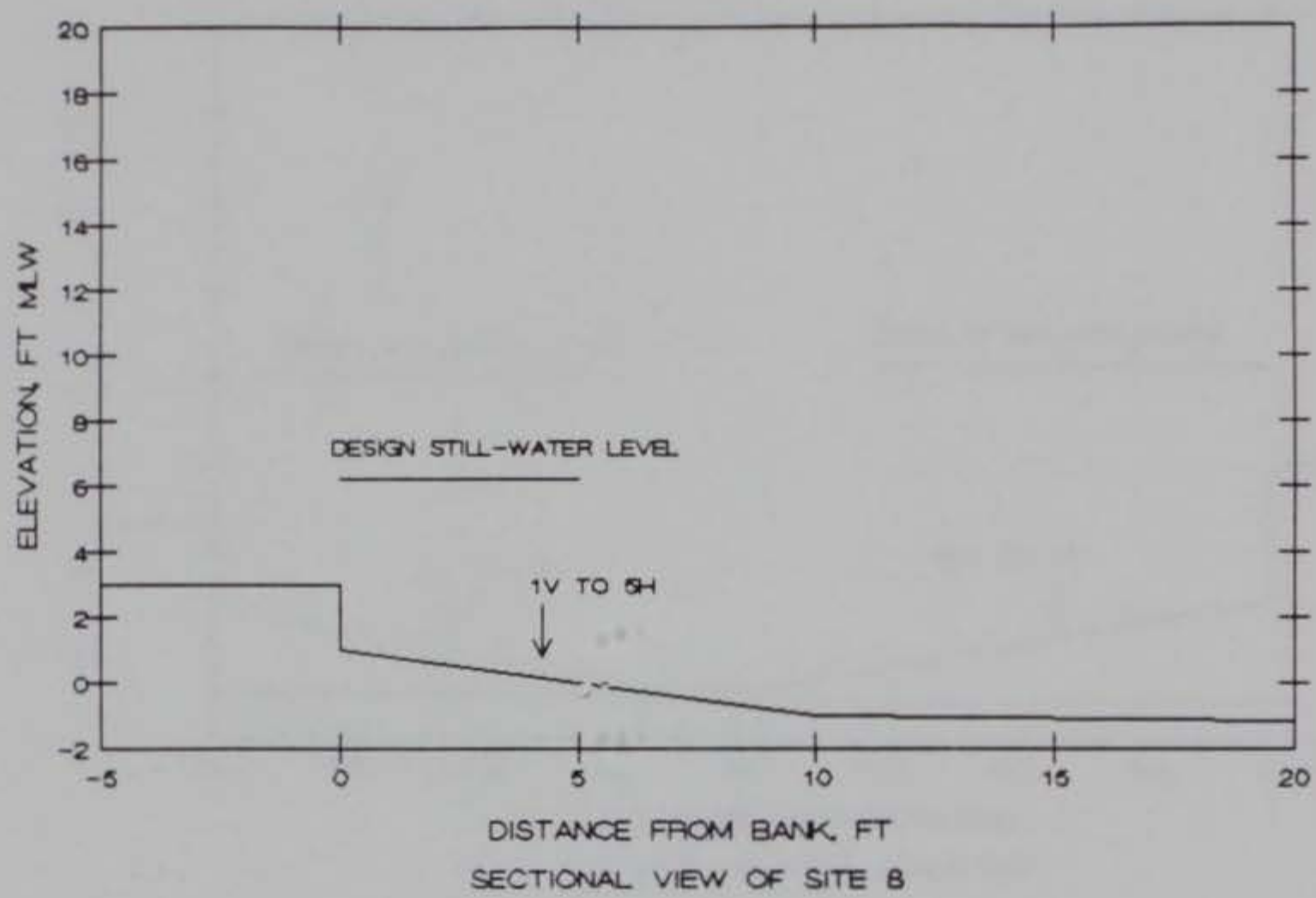

FIGURE 11. SECTIONAL AND PLAN VIEWS OF SITE 8

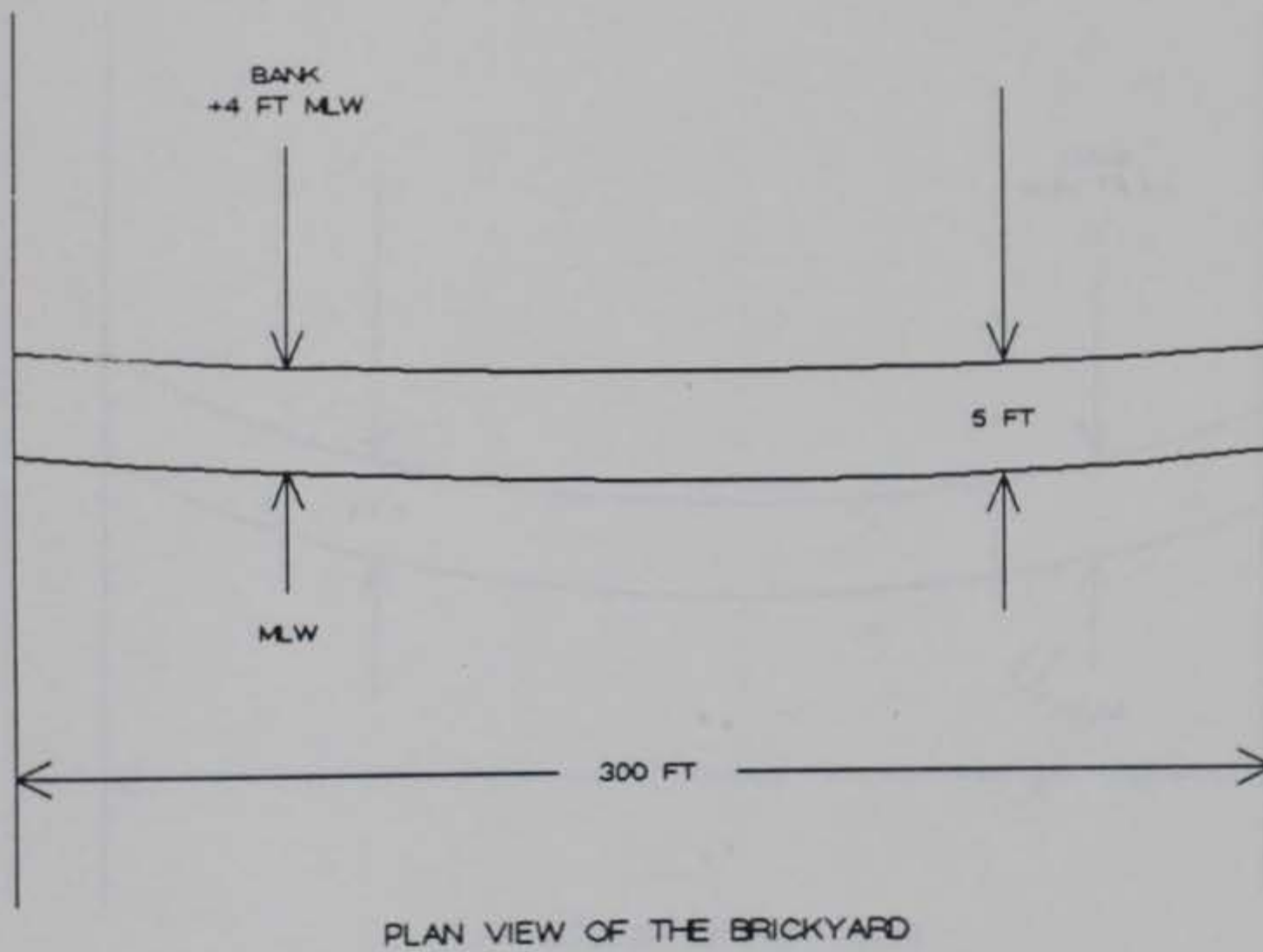
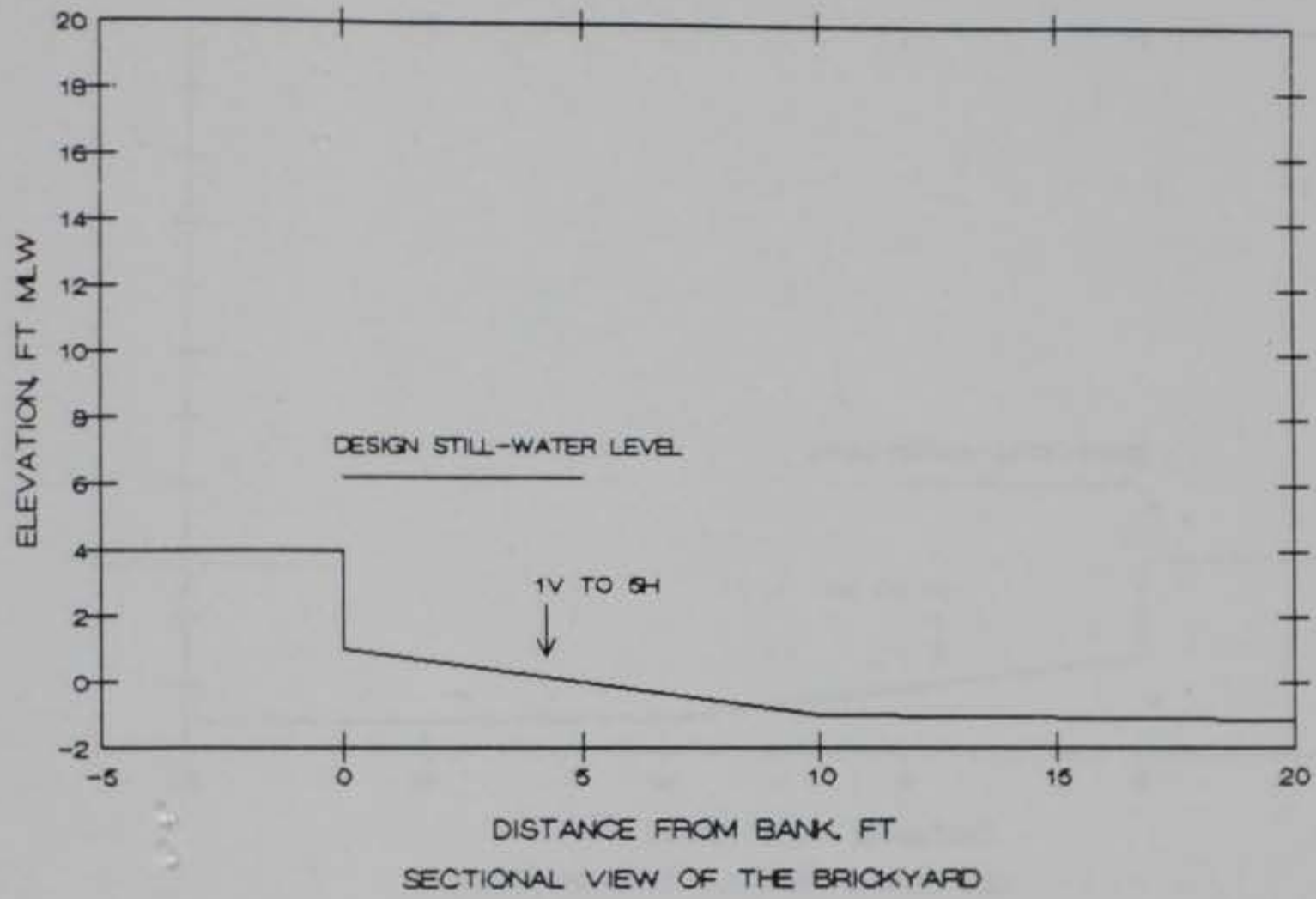

FIGURE 12. SECTIONAL AND PLAN VIEWS OF THE BRICKYARD

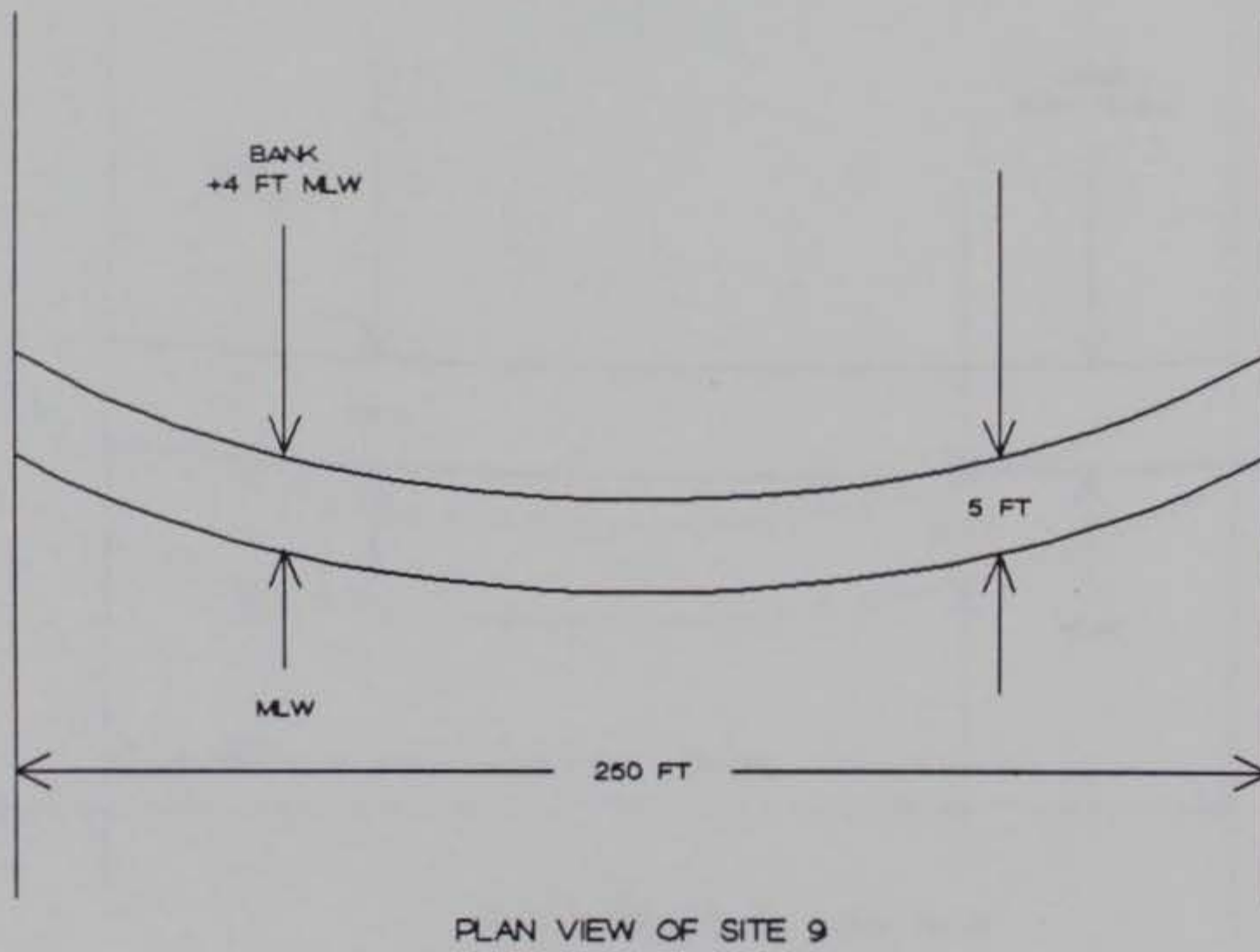
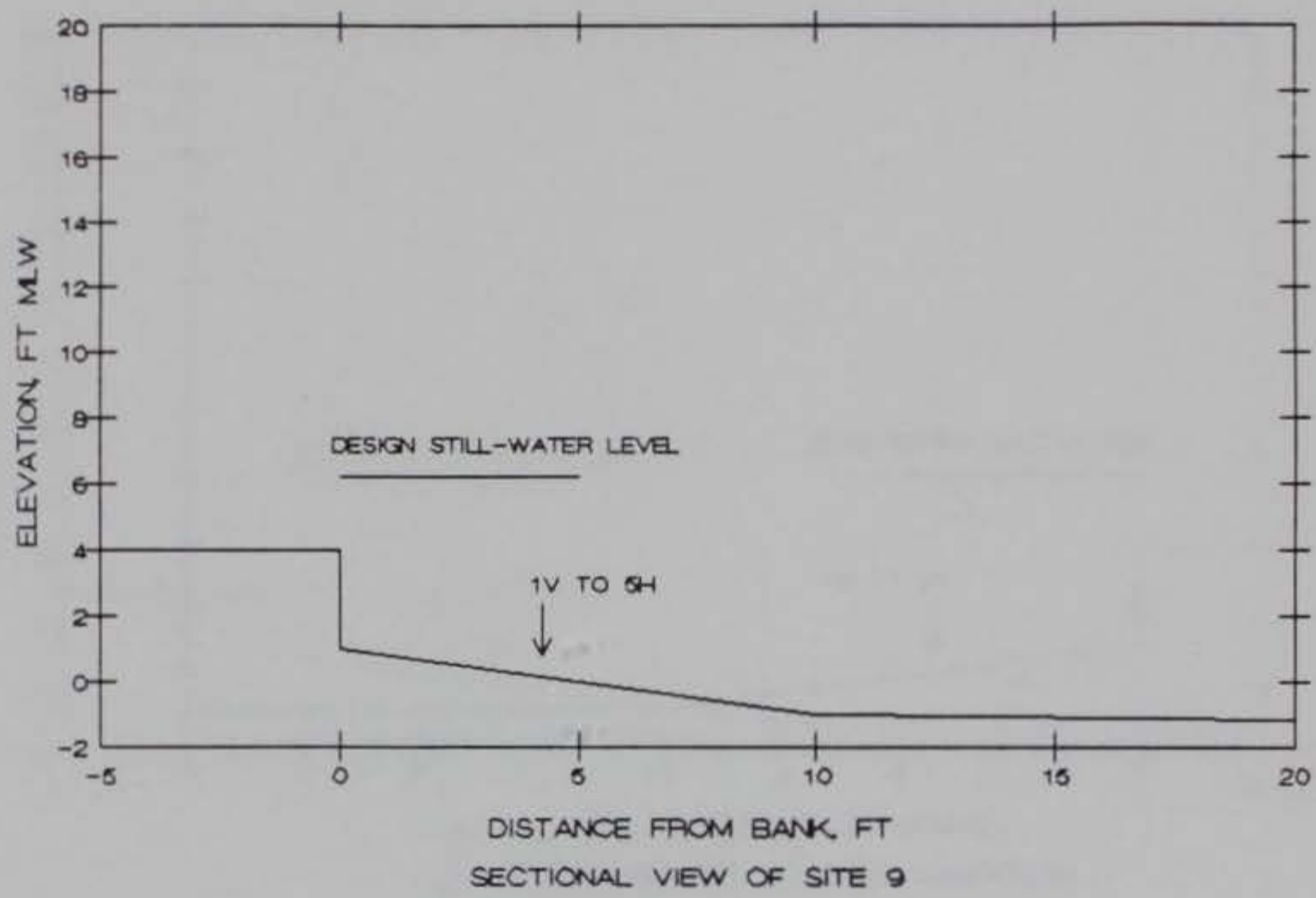

FIGURE 13. SECTIONAL AND PLAN VIEWS OF SITE 9

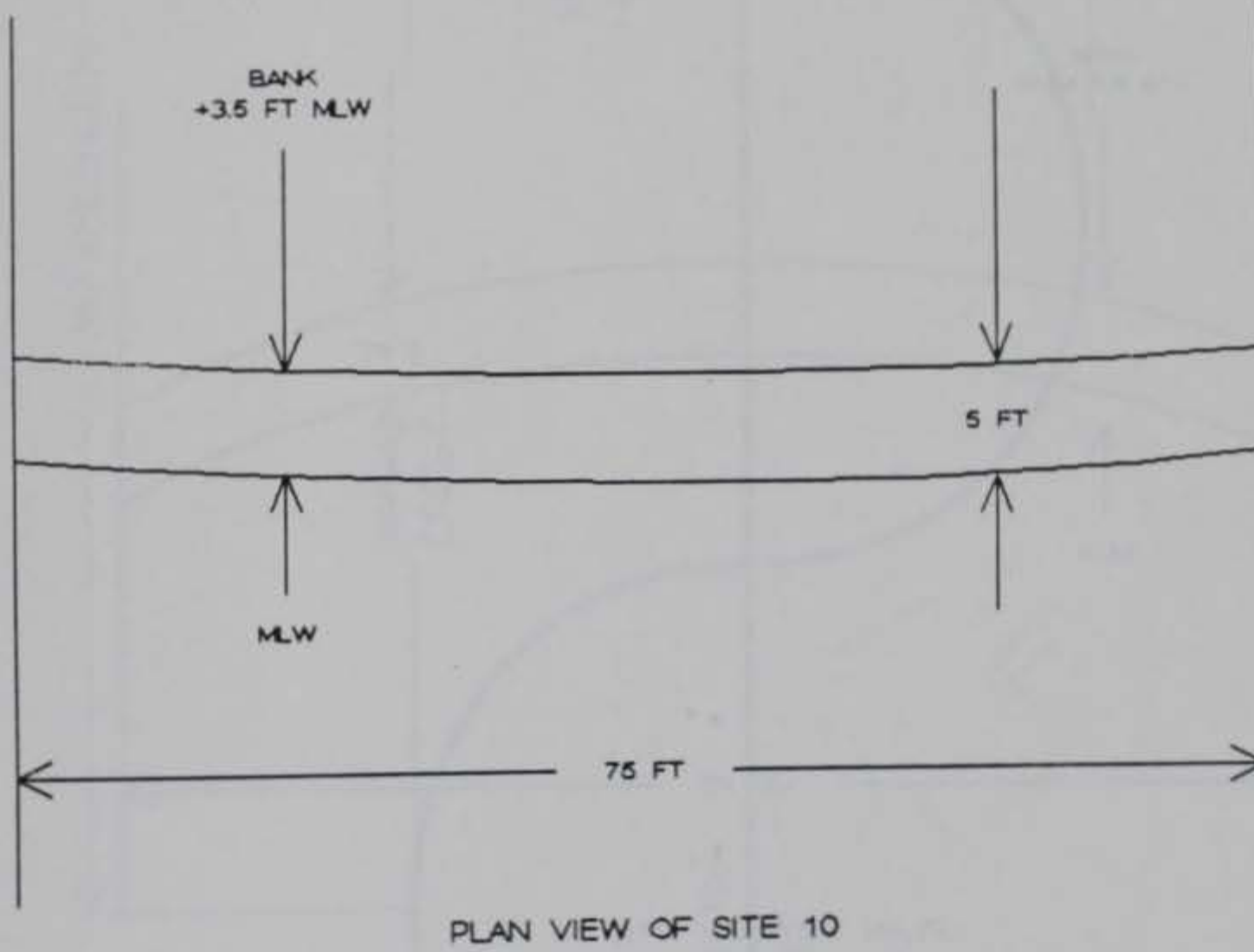
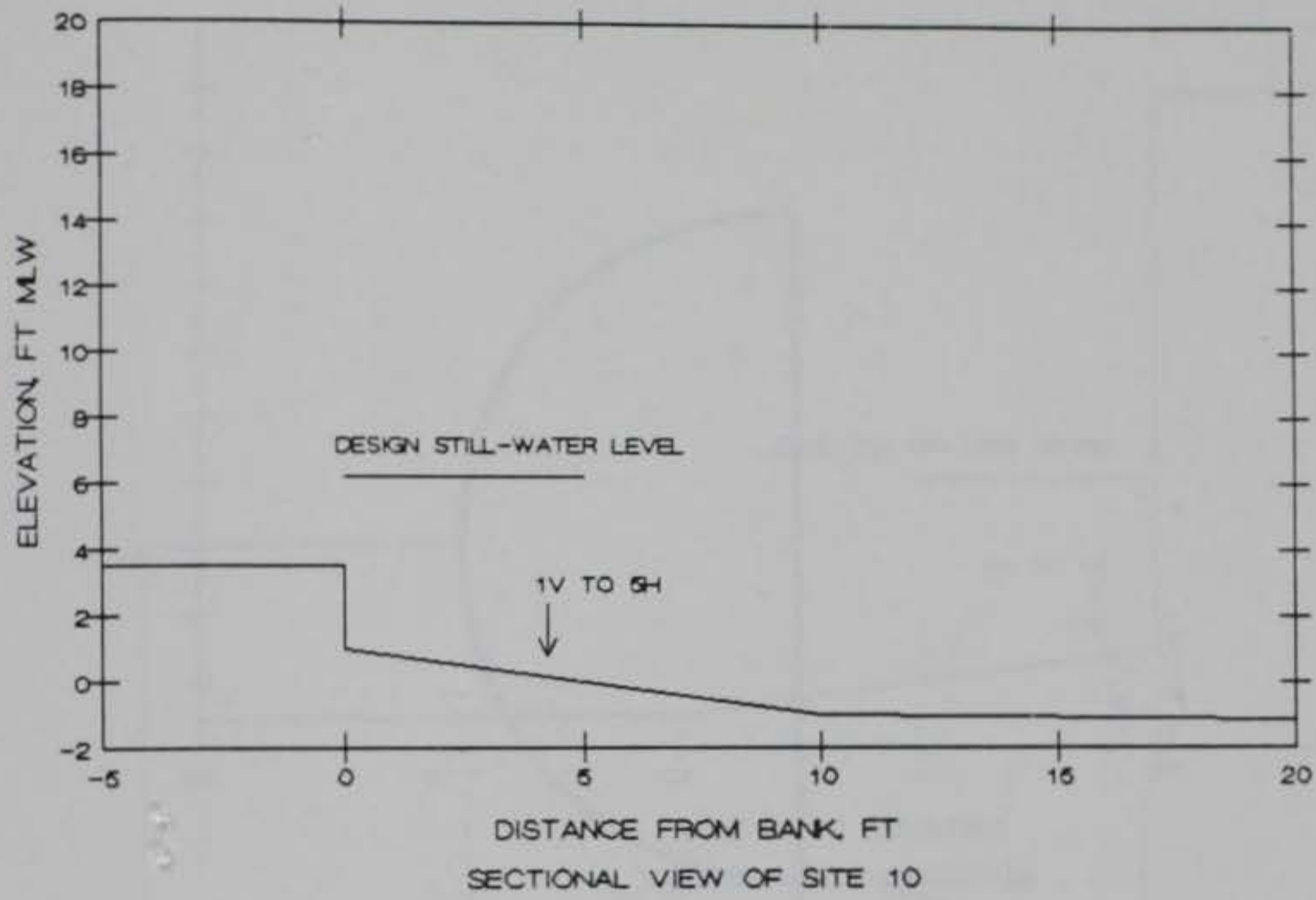

FIGURE 14. SECTIONAL AND PLAN VIEWS OF SITE 10

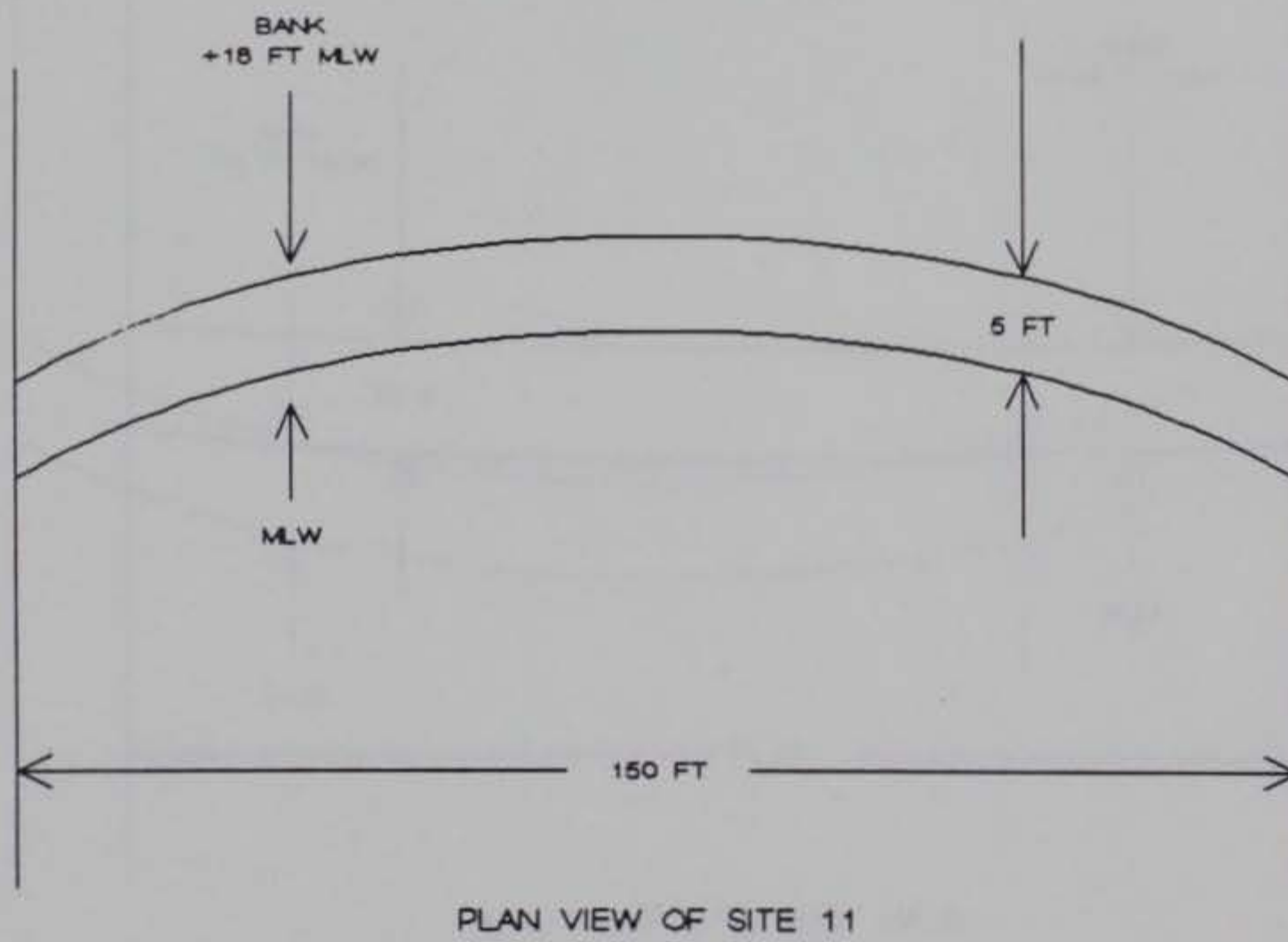
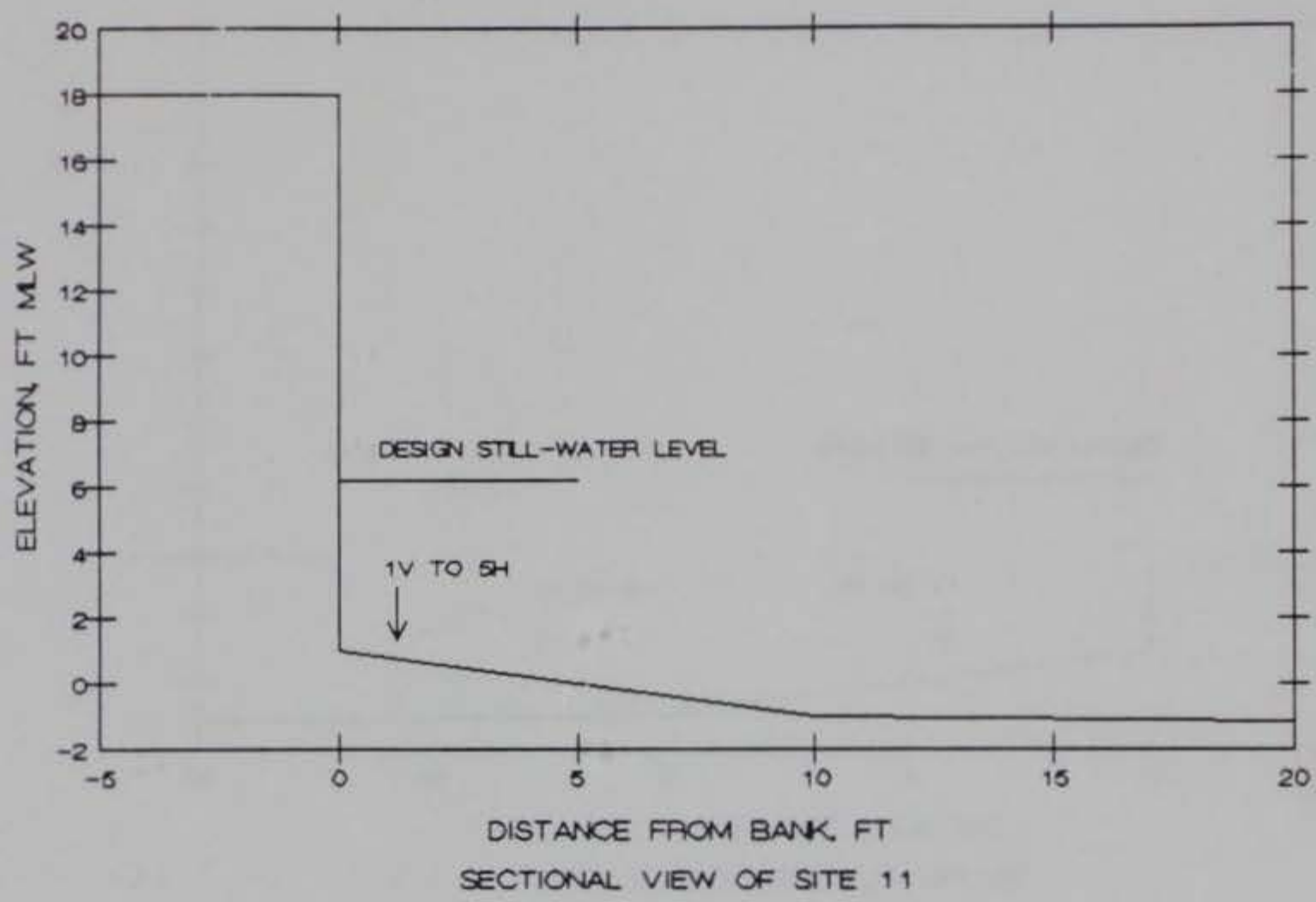

FIGURE 15. SECTIONAL AND PLAN VIEWS OF SITE 11

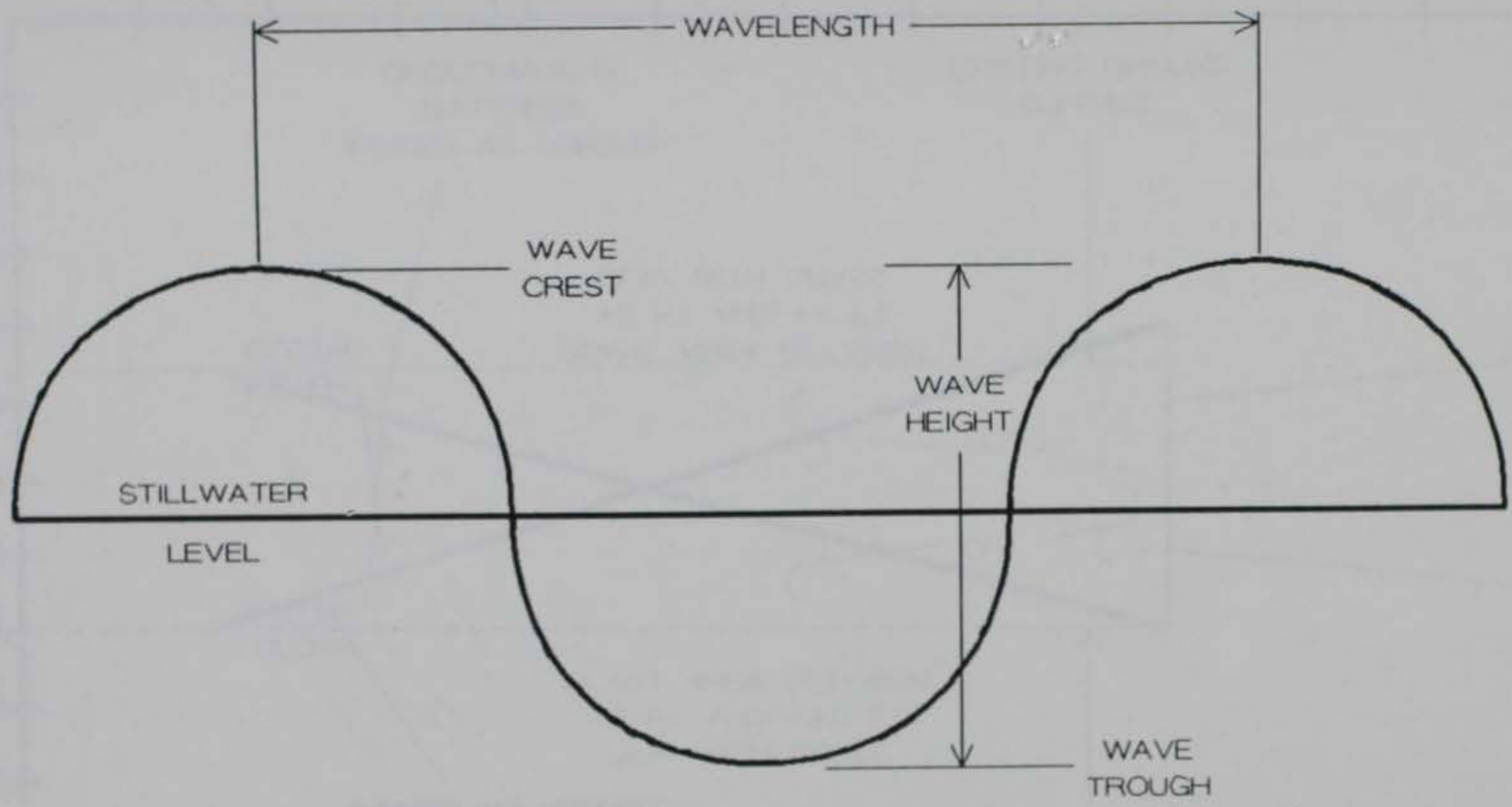

FIGURE 16. CHARACTERISTICS OF WAVES

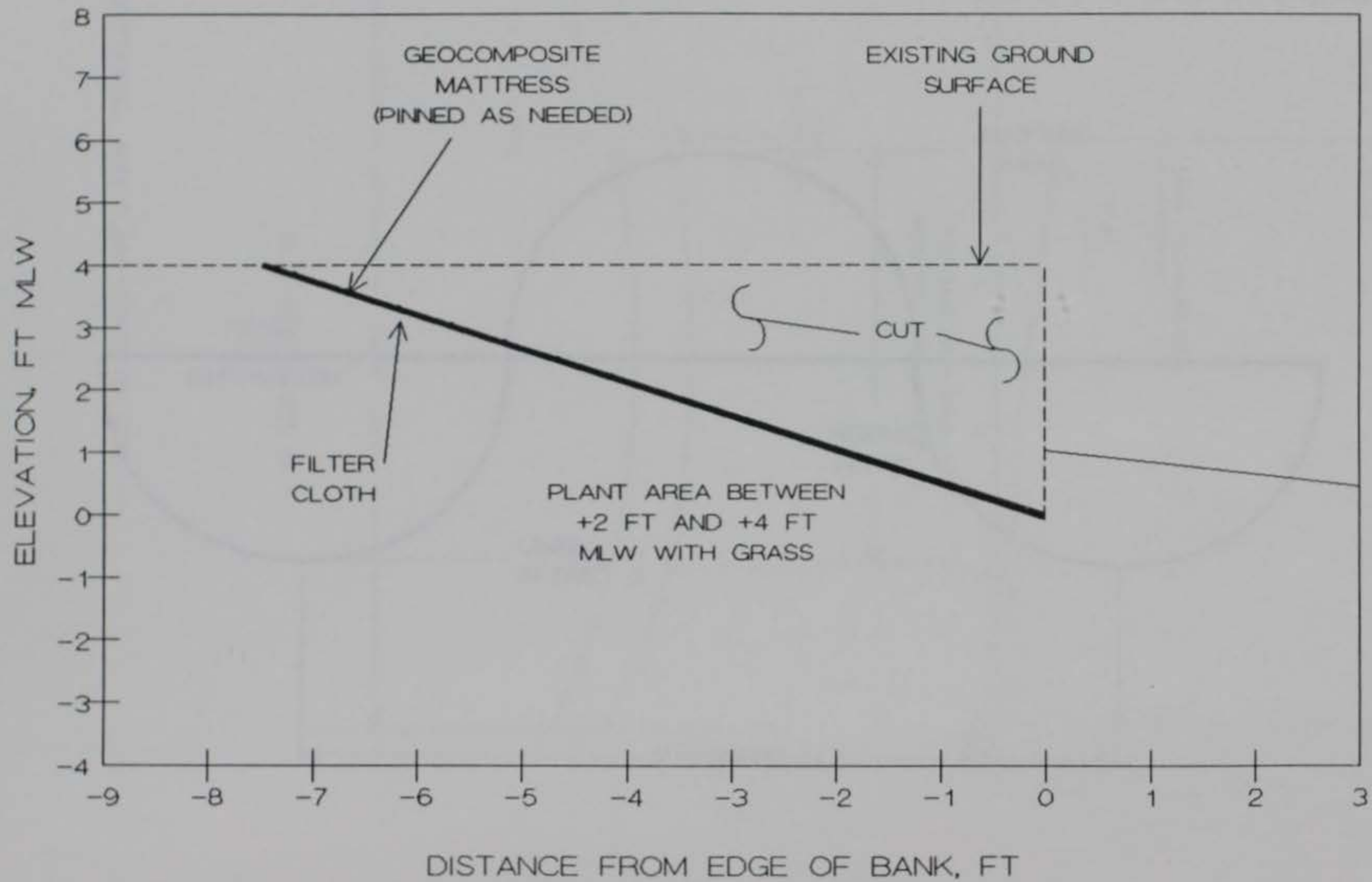

FIGURE 17. GEOCOMPOSITE MATTRESS PROPOSED FOR SITE 9

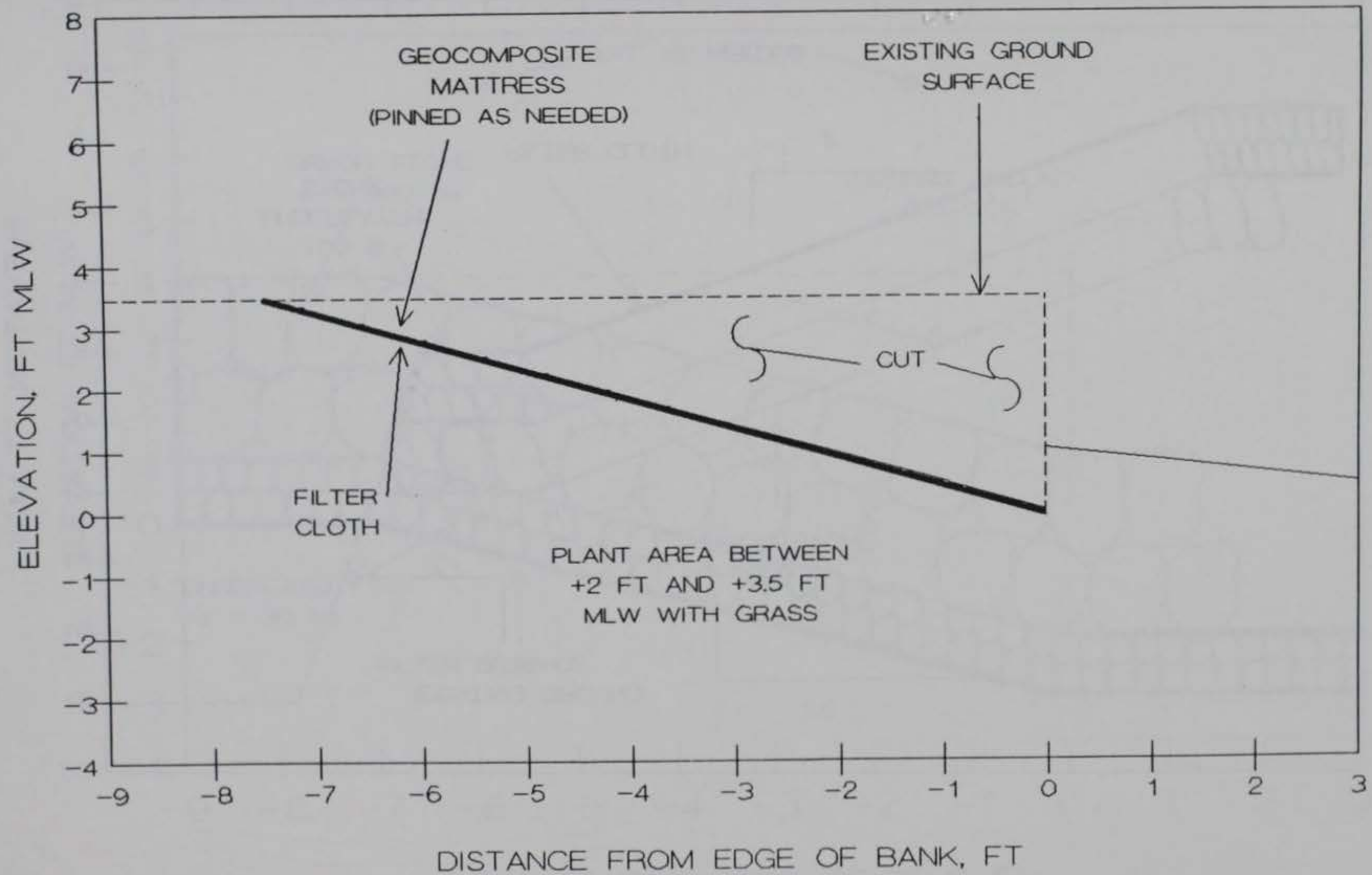

FIGURE 18. GEOCOMPOSITE MATTRESS PROPOSED FOR SITE 10

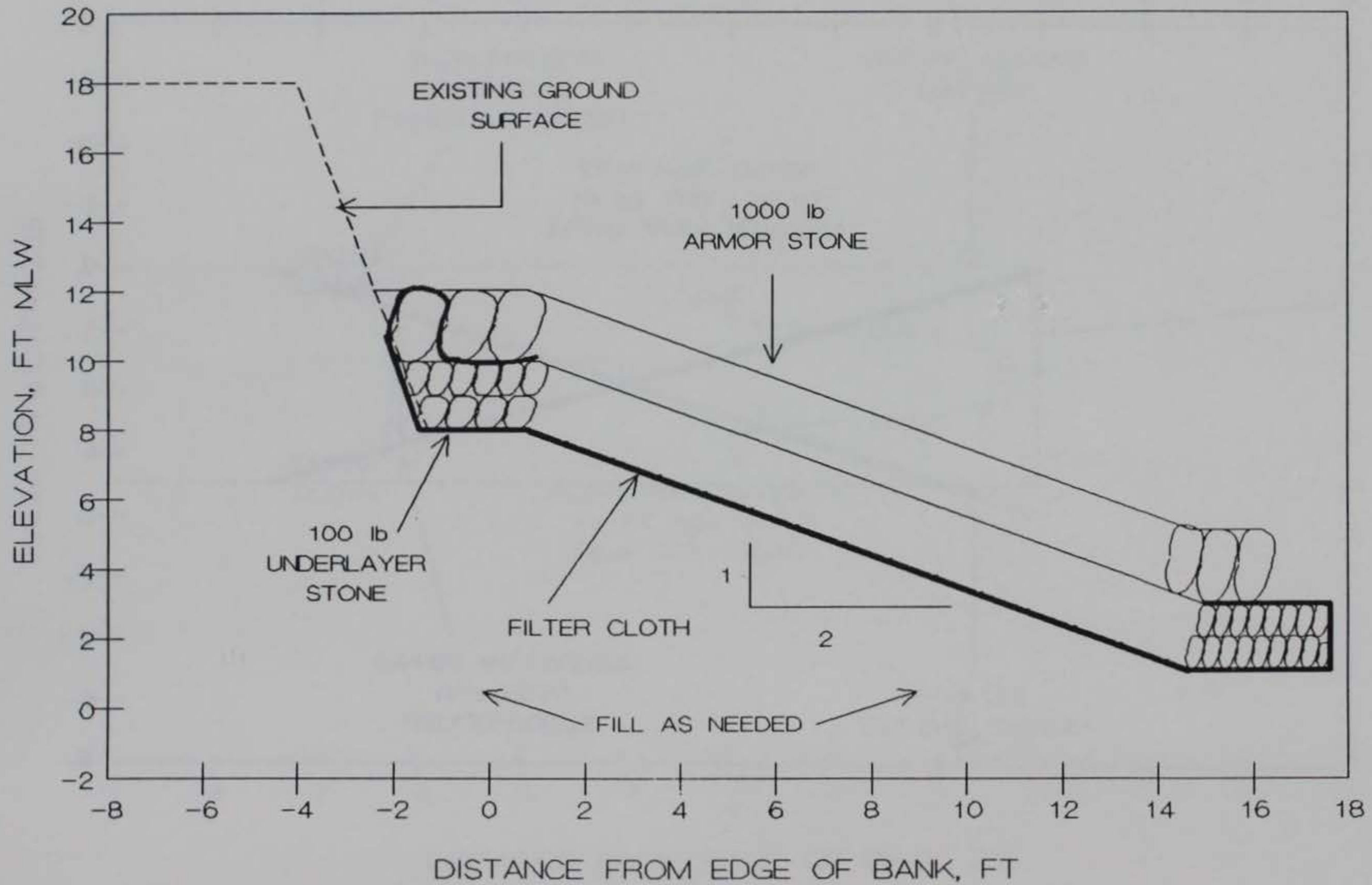

FIGURE 19. PLACED RIPRAP REVETMENT PROPOSED FOR SITE 1

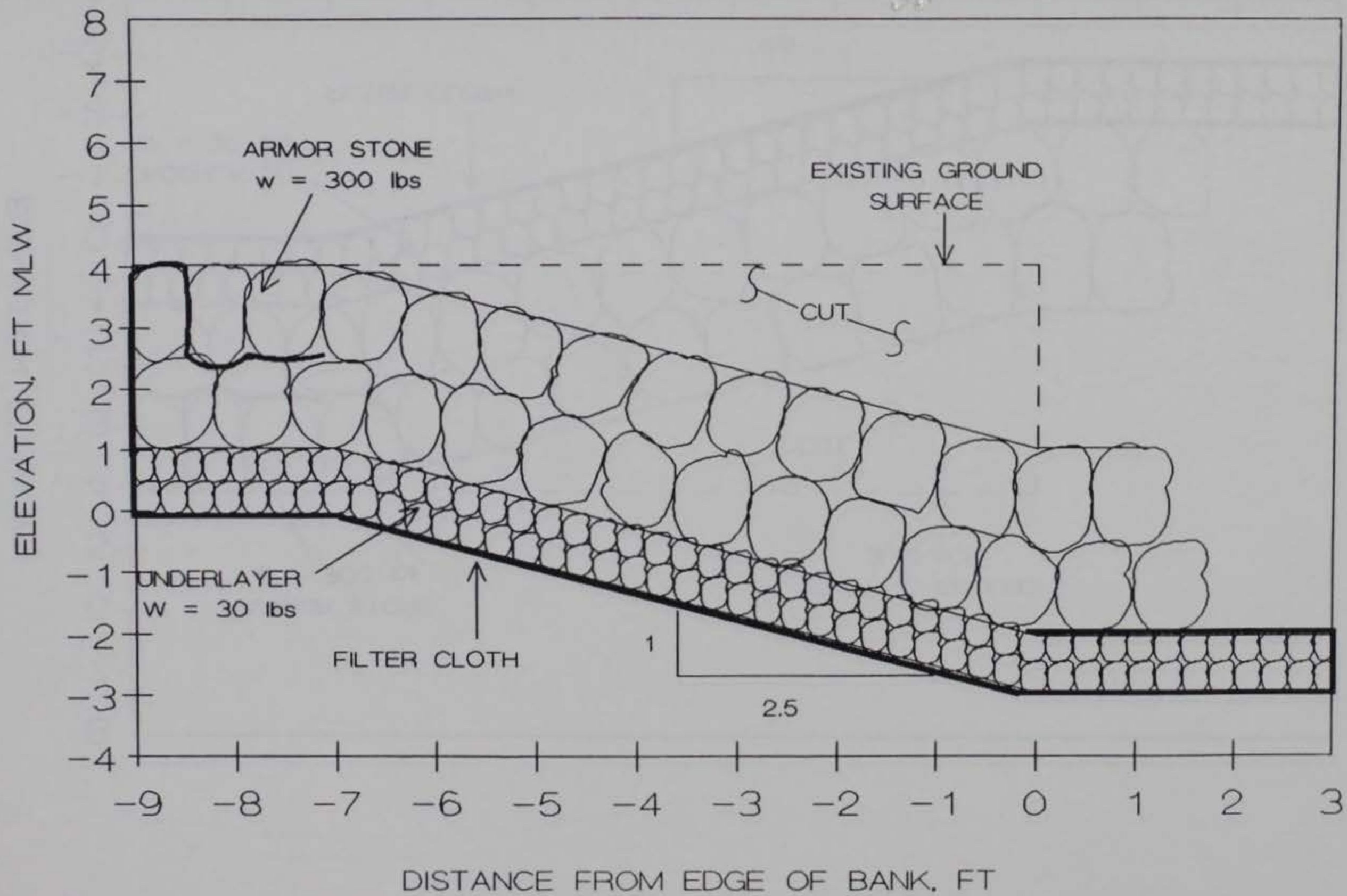

FIGURE 20. PLACED RIPRAP REVETMENT PROPOSED FOR SITE 2

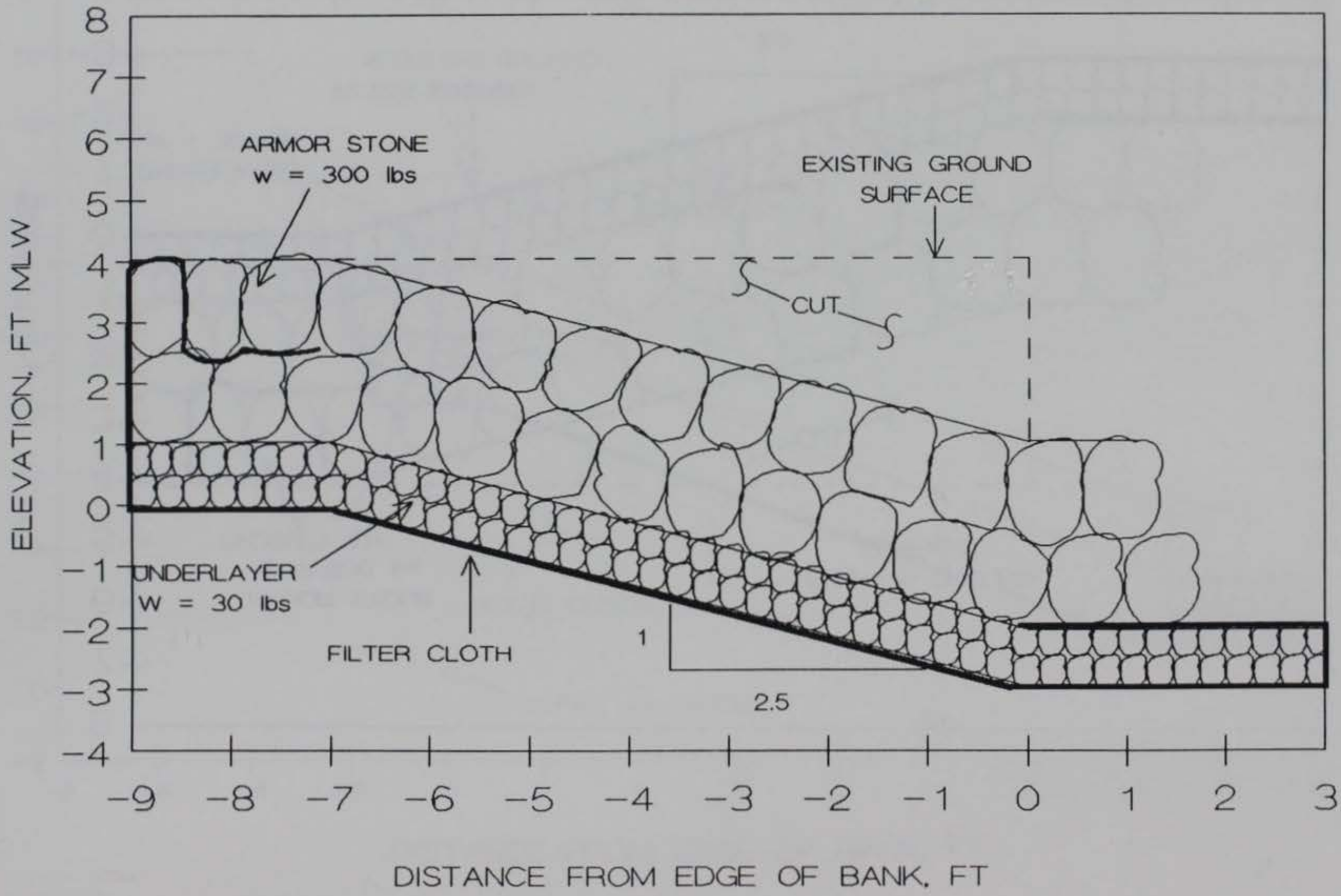

FIGURE 21. PLACED RIPRAP REVETMENT PROPOSED FOR SITE 2A

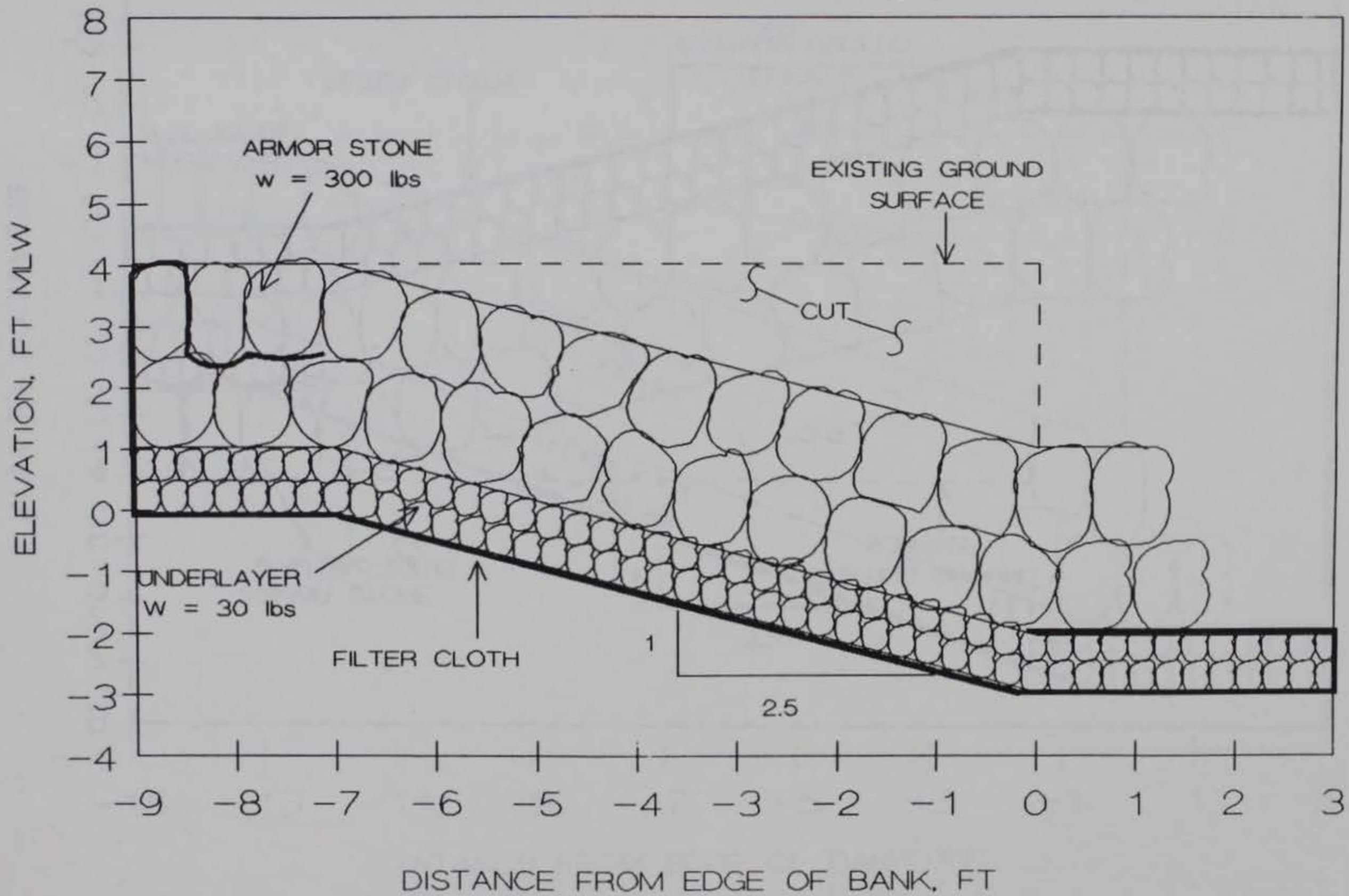

FIGURE 22. PLACED RIPRAP REVETMENT PROPOSED FOR SITE 3

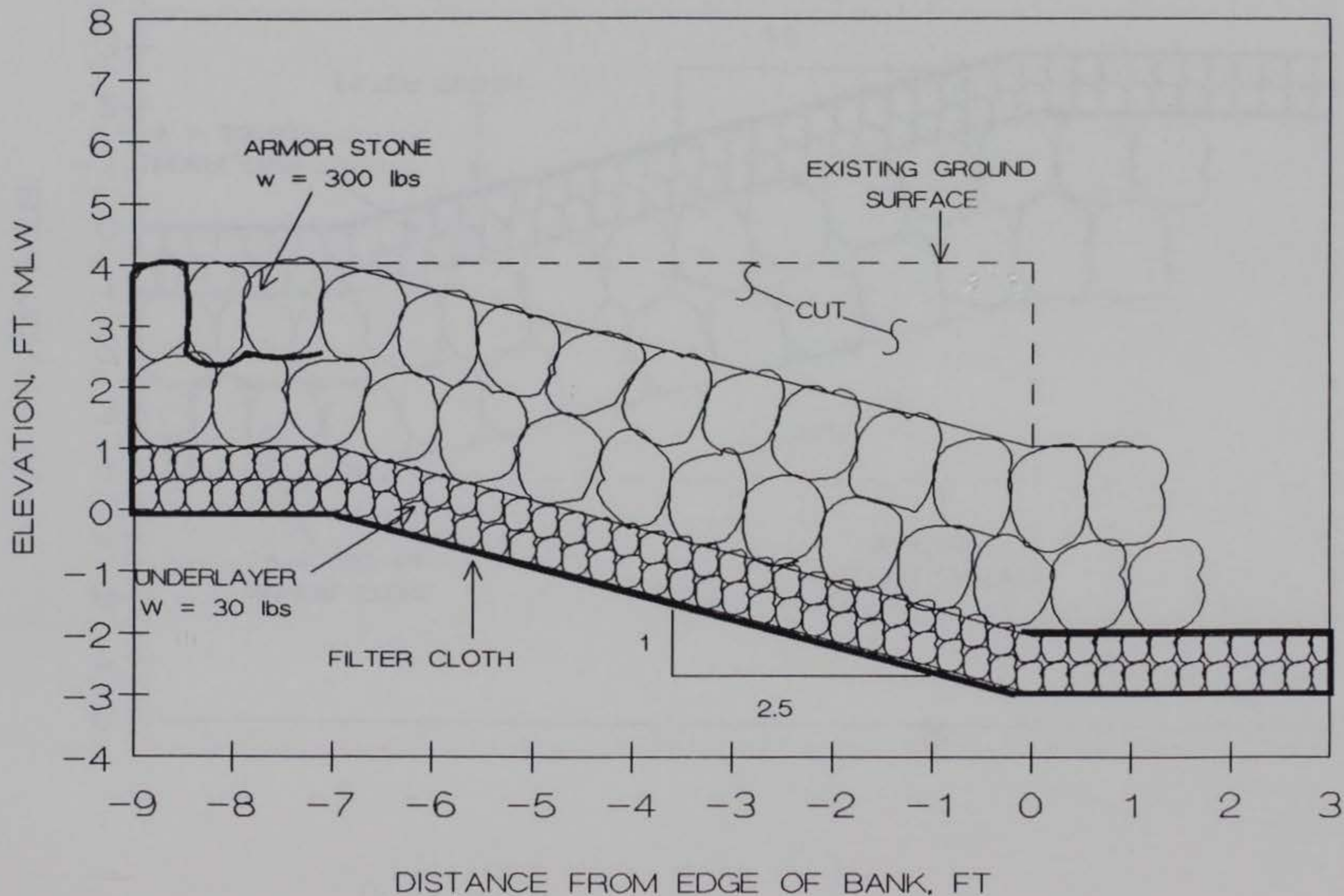

FIGURE 23. PLACED RIPRAP REVETMENT PROPOSED FOR SITE 4

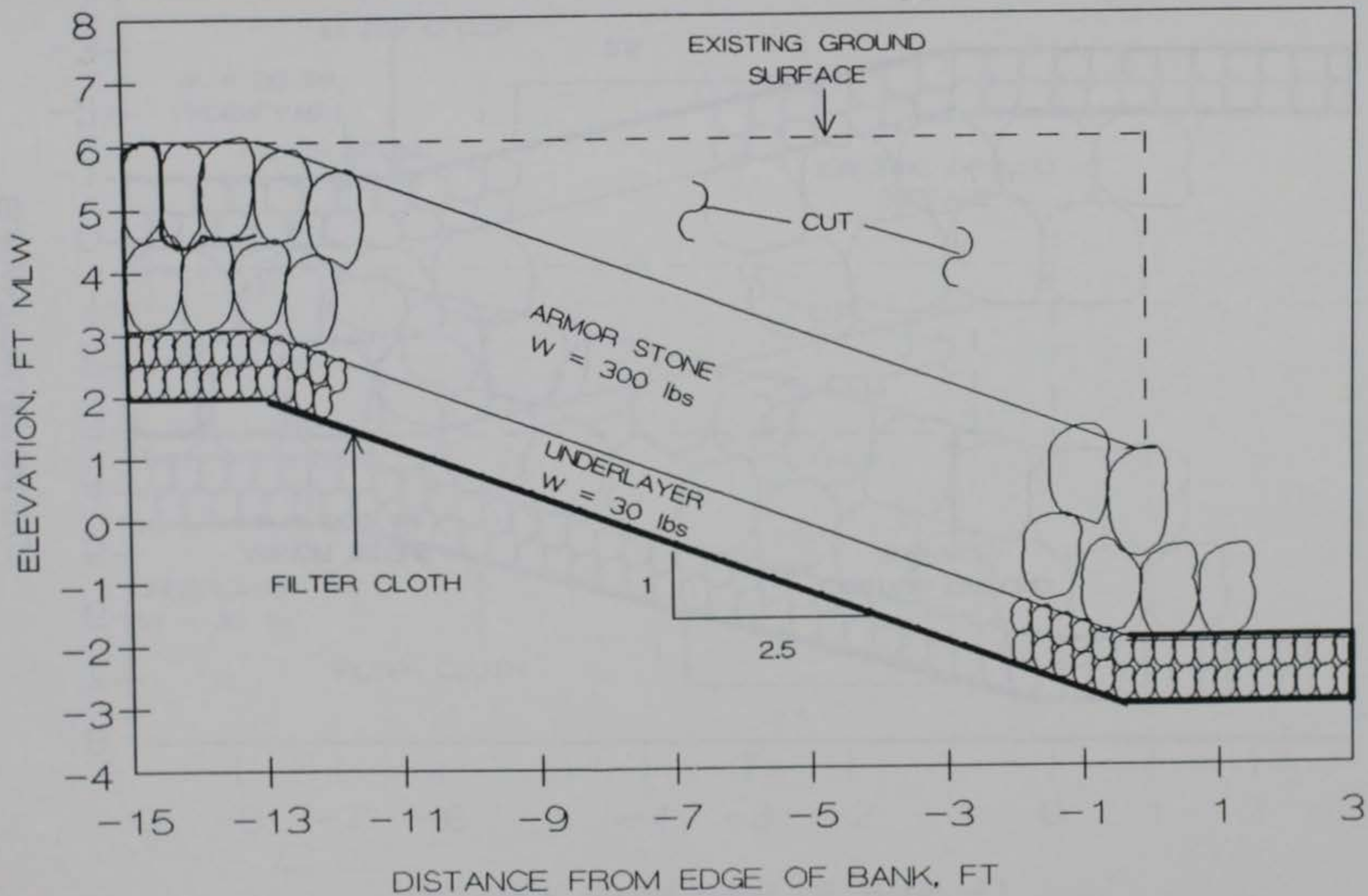

FIGURE 24. PLACED RIPRAP REVETMENT PROPOSED FOR SITE 5

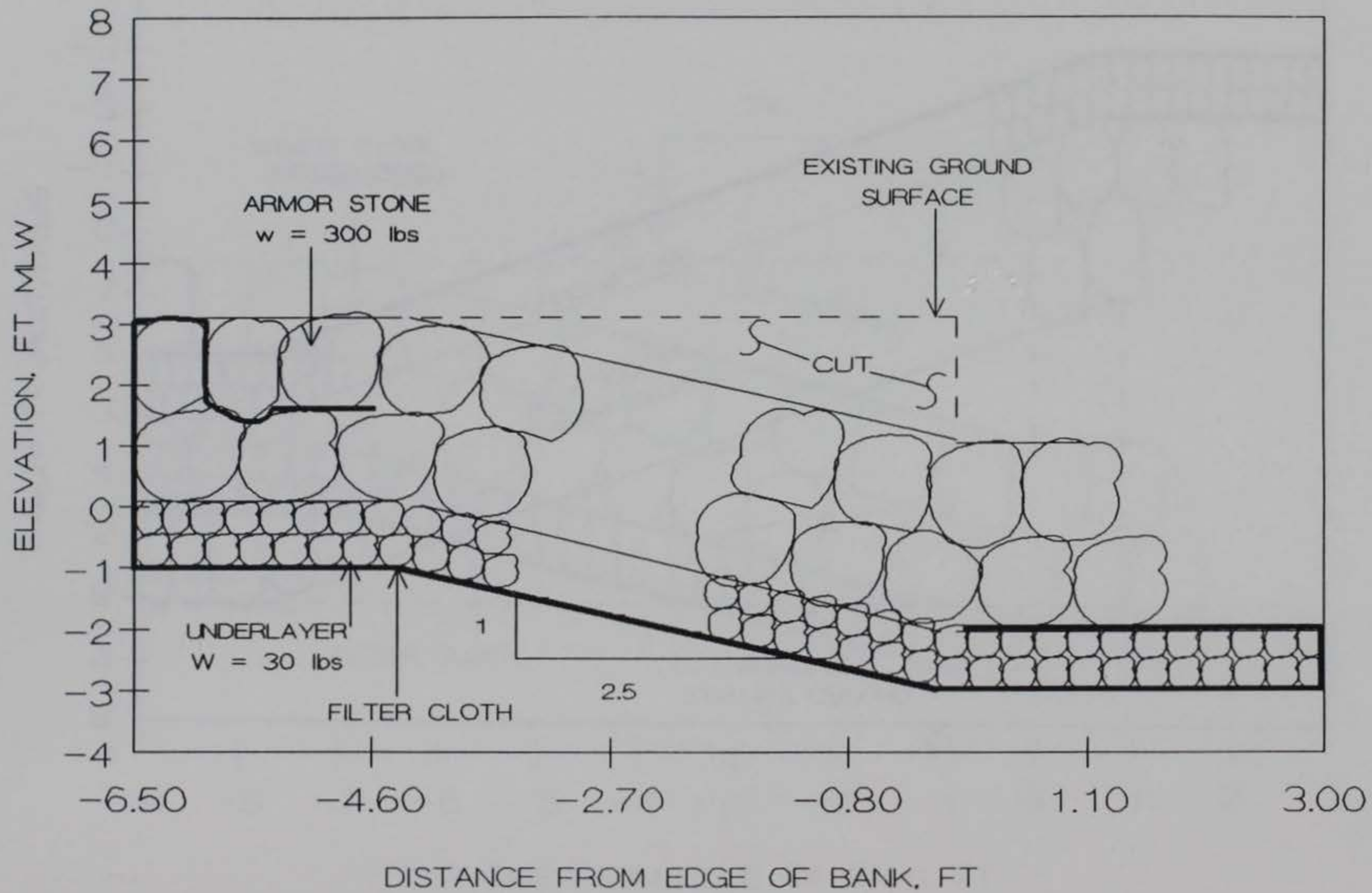

FIGURE 25. PLACED RIPRAP REVETMENT PROPOSED FOR SITE 6

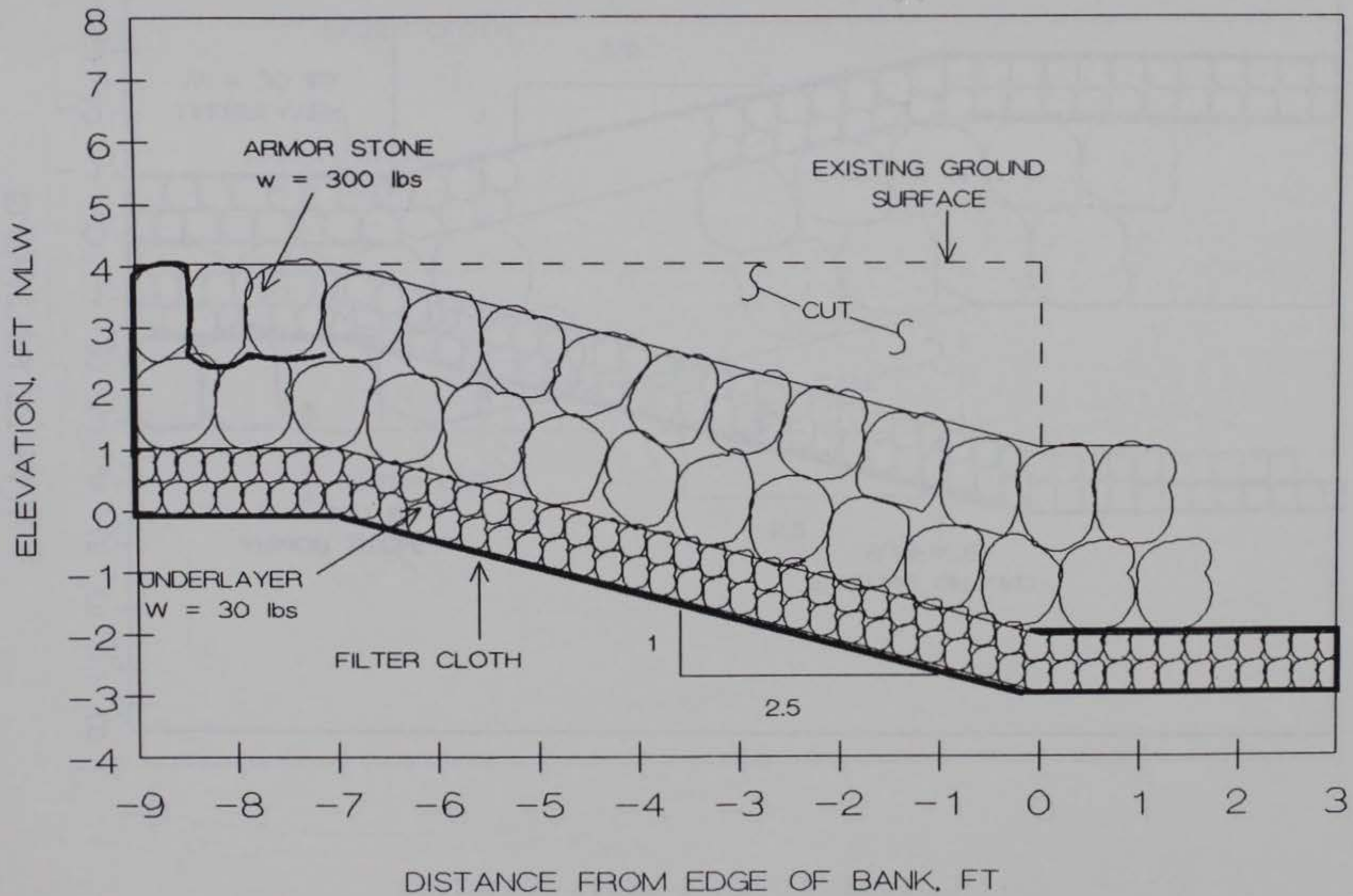

FIGURE 26. PLACED RIPRAP REVETMENT PROPOSED FOR SITE 7

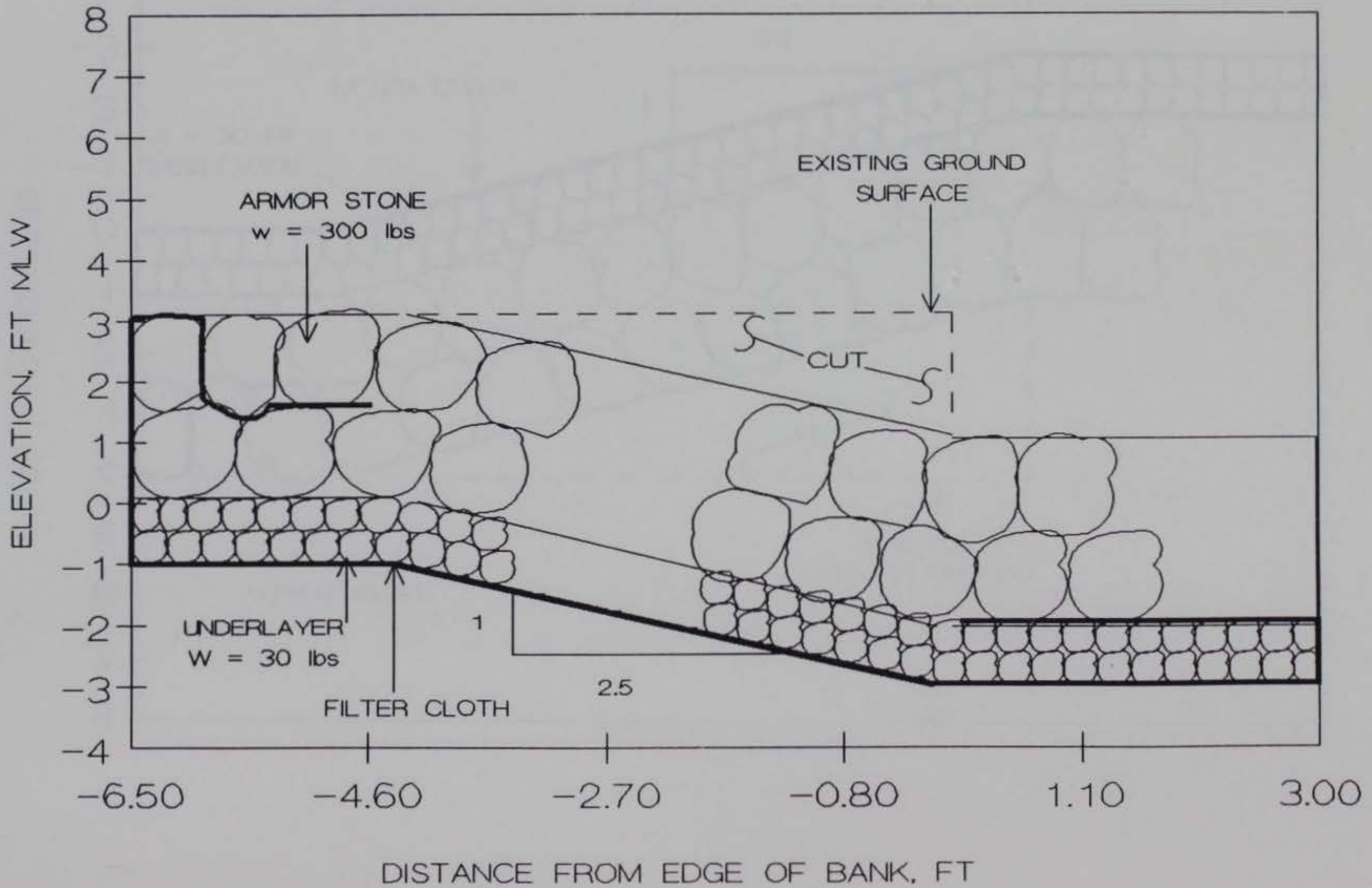

FIGURE 27. PLACED RIPRAP REVETMENT PROPOSED FOR SITE 8

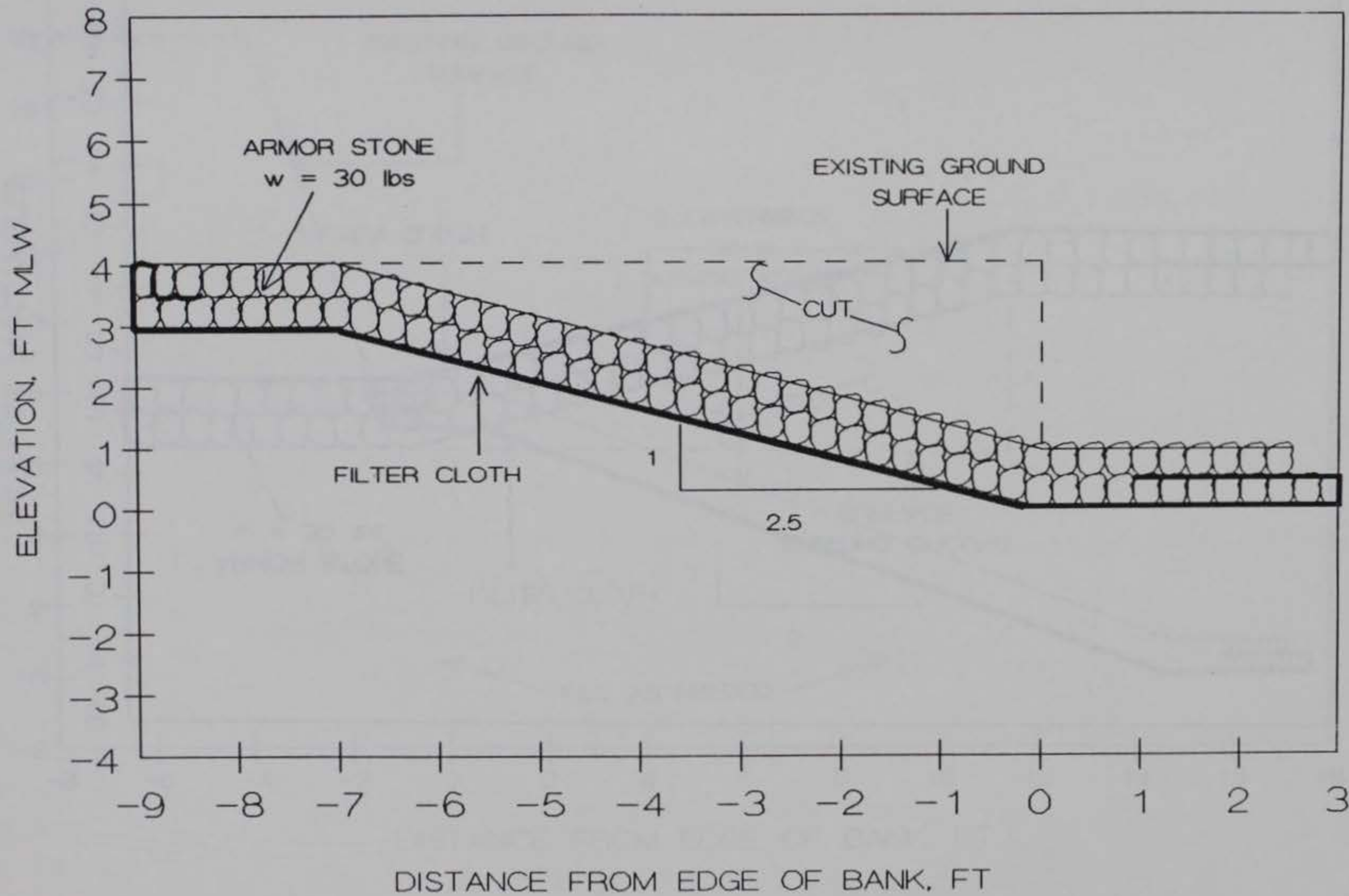

FIGURE 28. PLACED RIPRAP REVETMENT PROPOSED FOR SITE 9

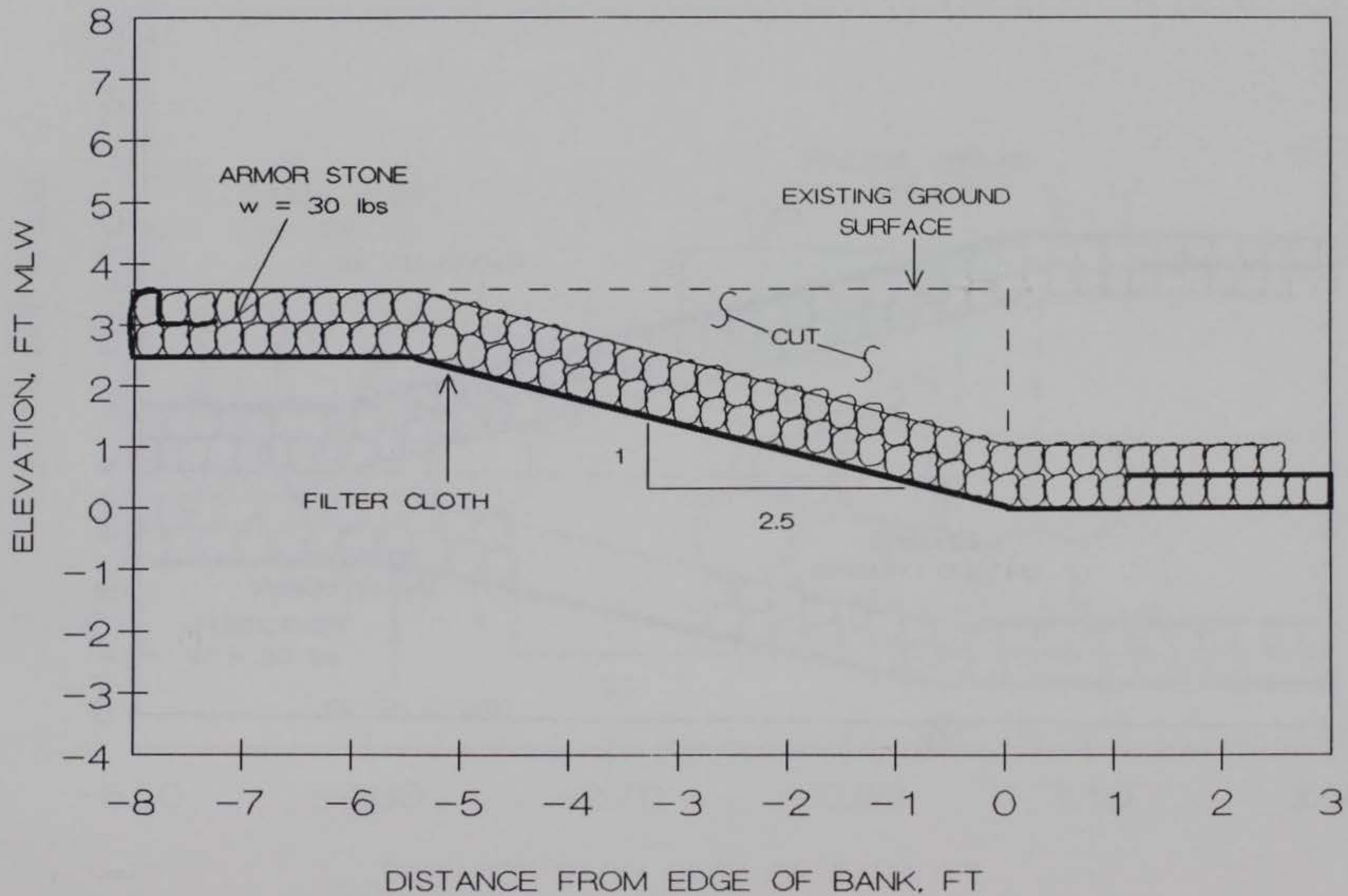

FIGURE 29. PLACED RIPRAP REVETMENT PROPOSED FOR SITE 10

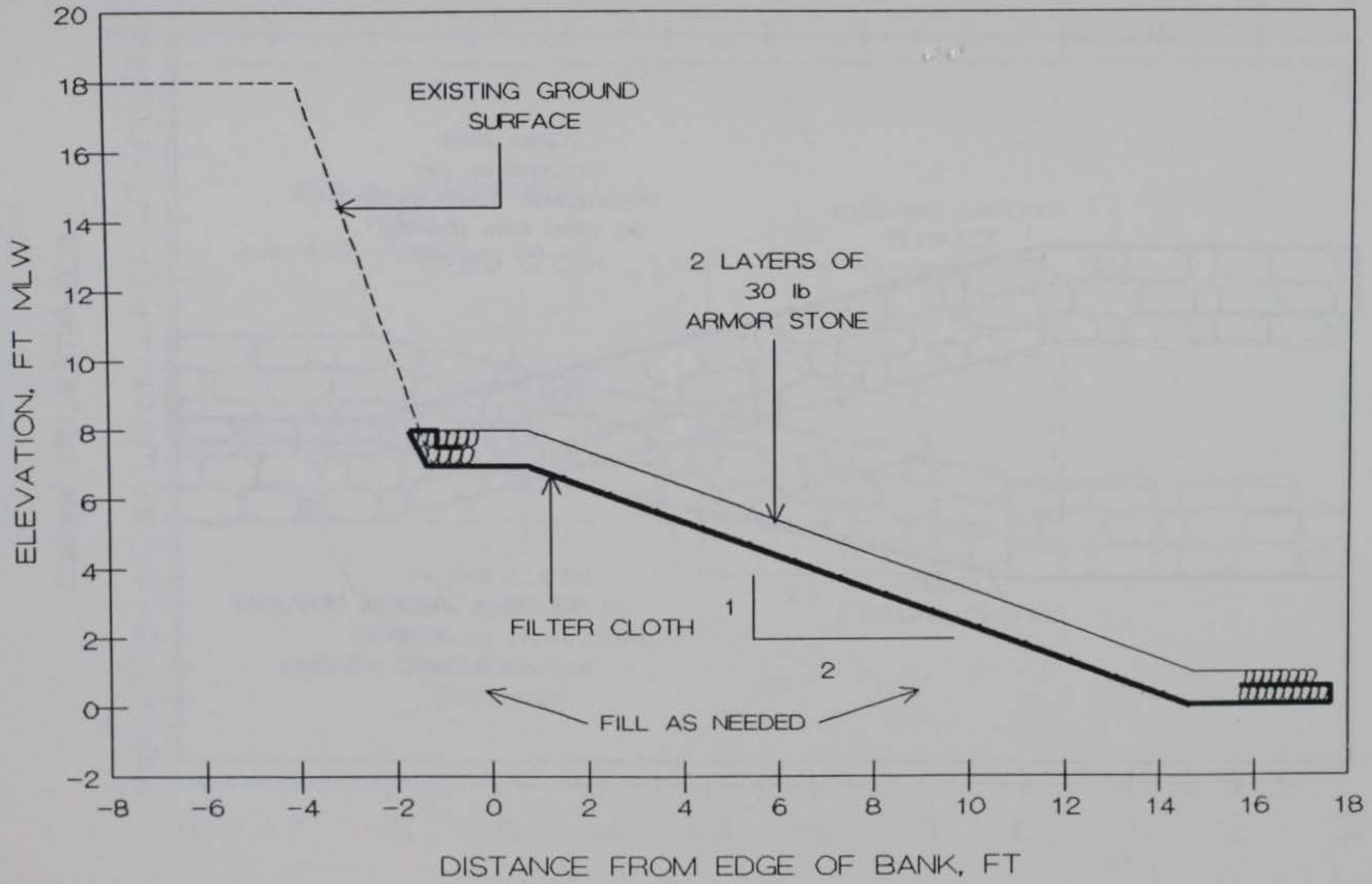

FIGURE 30. PLACED RIPRAP REVETMENT PROPOSED FOR SITE 11

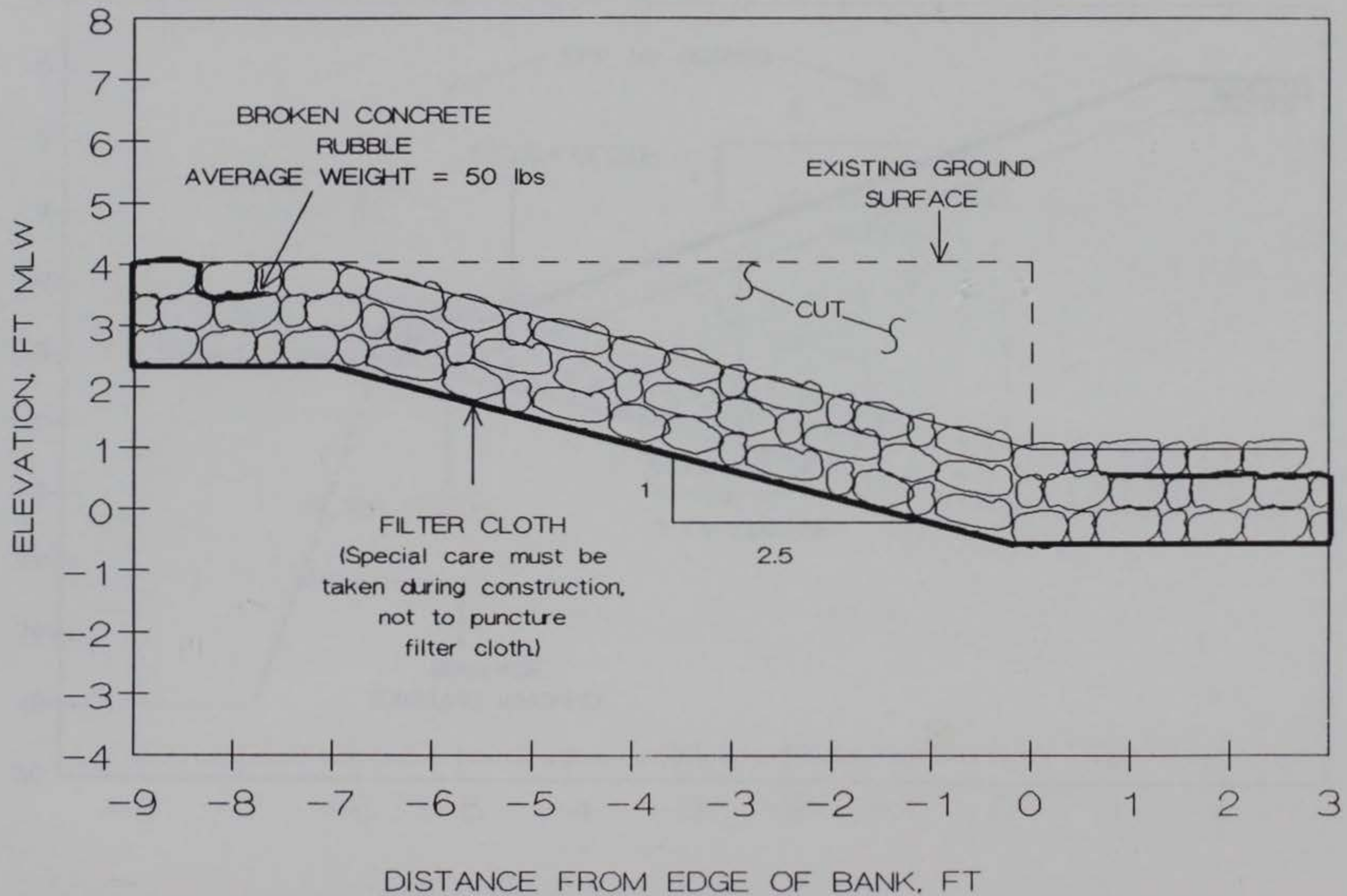

FIGURE 31. BROKEN CONCRETE REVETMENT PROPOSED FOR SITE 9

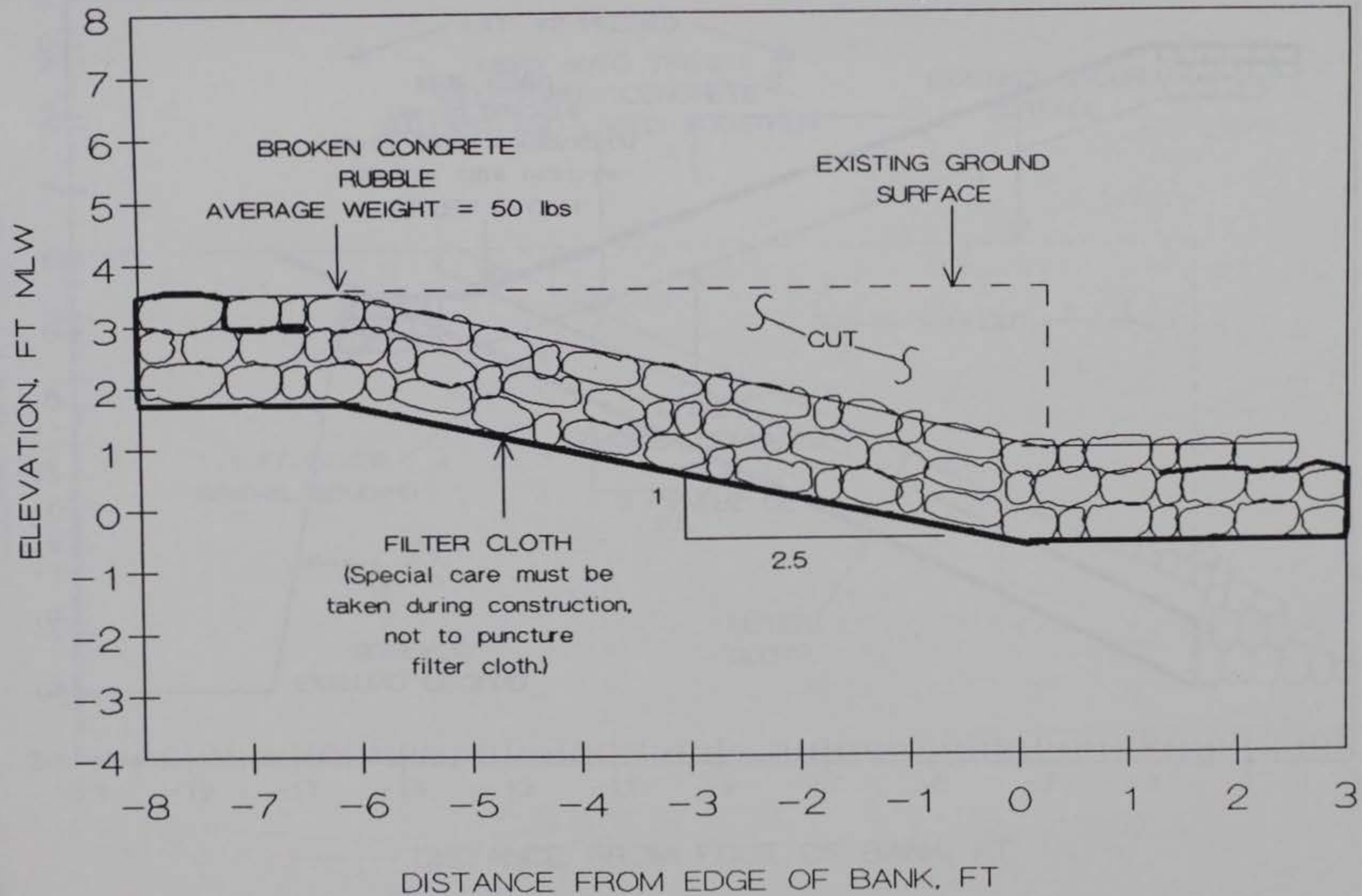

FIGURE 32. BROKEN CONCRETE REVETMENT PROPOSED FOR SITE 10

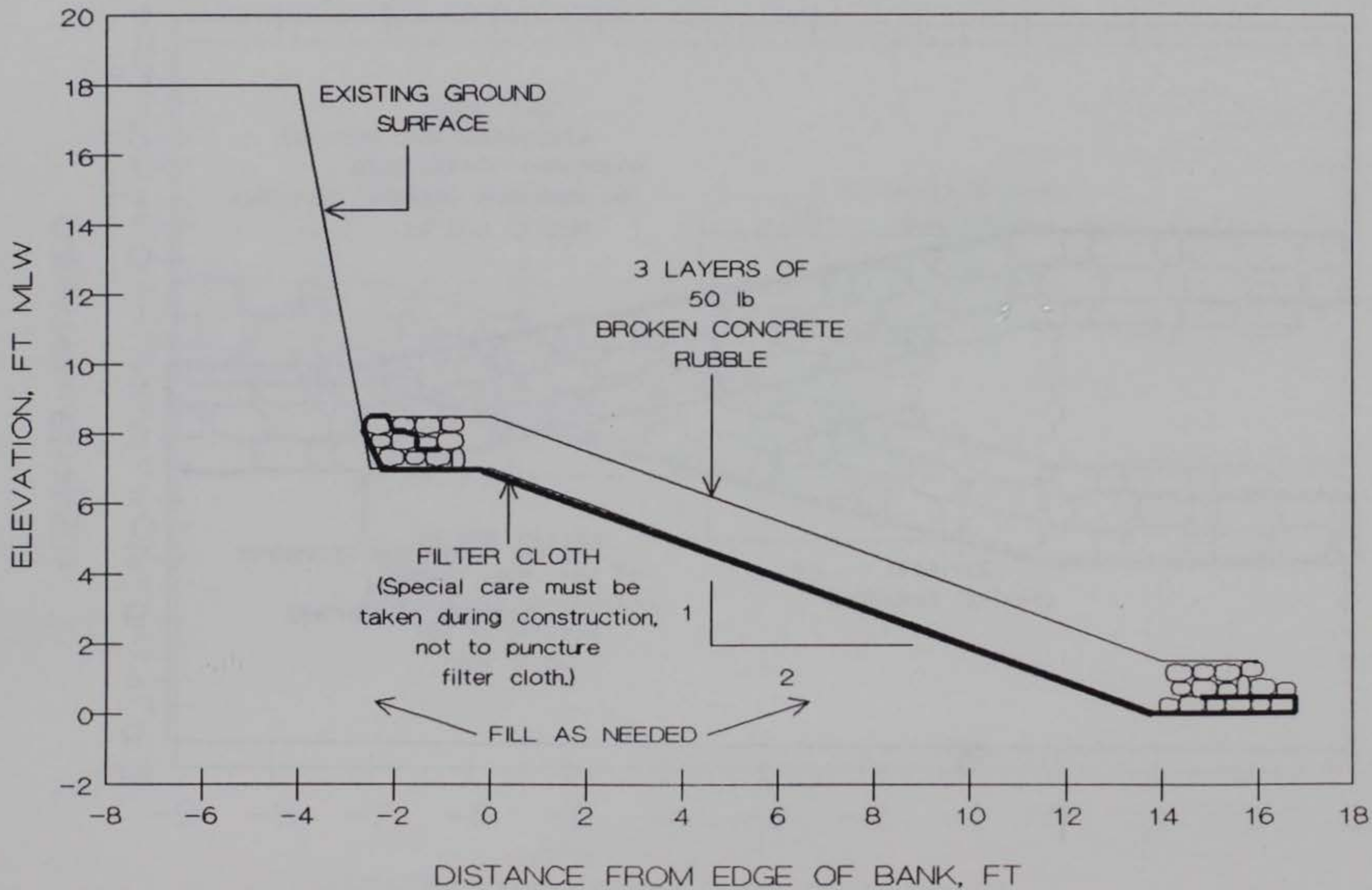

FIGURE 33. BROKEN CONCRETE REVETMENT PROPOSED FOR SITE 11

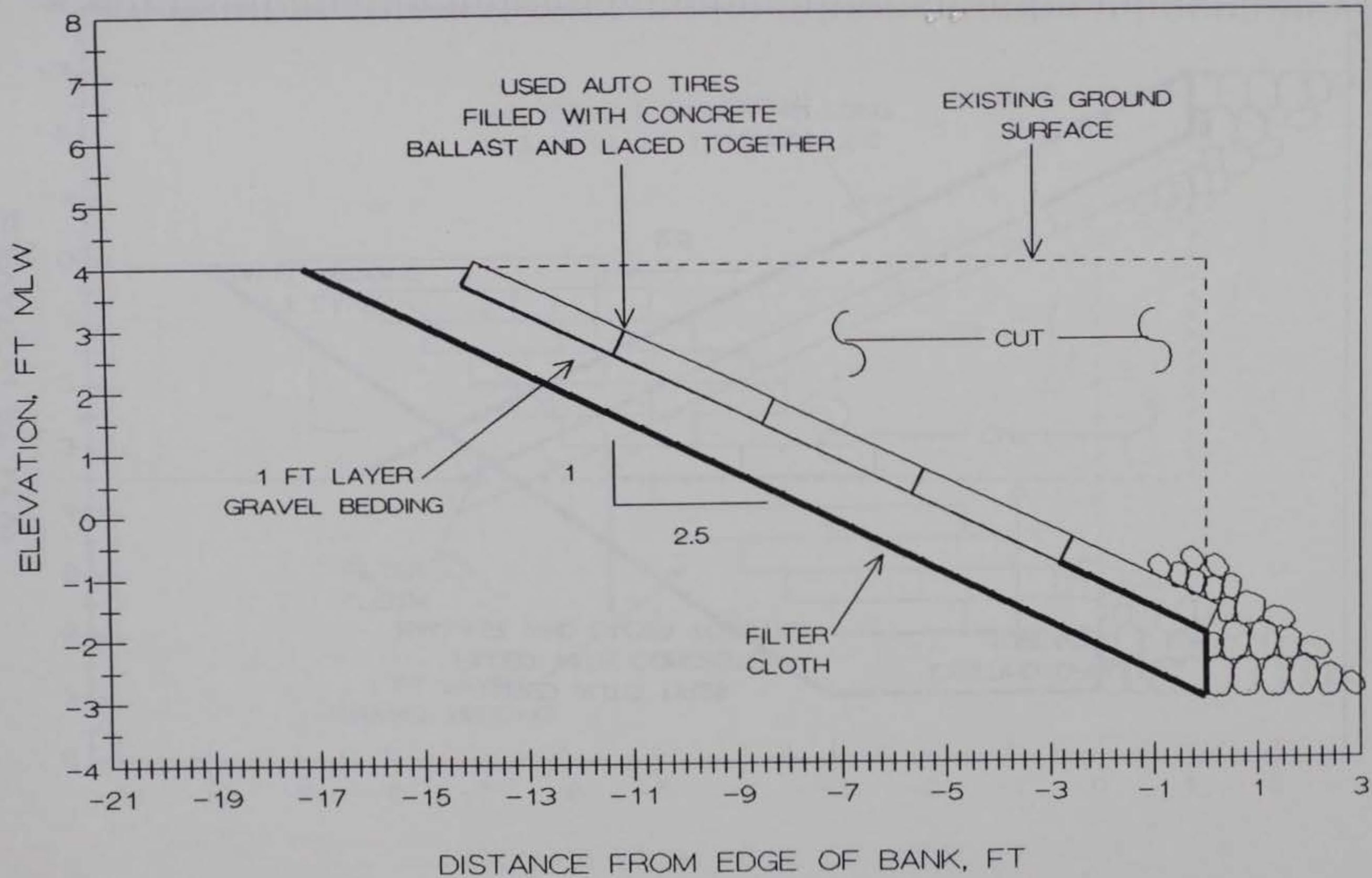

FIGURE 34. USED AUTO TIRE MATTRESS REVETMENT PROPOSED FOR SITE 9

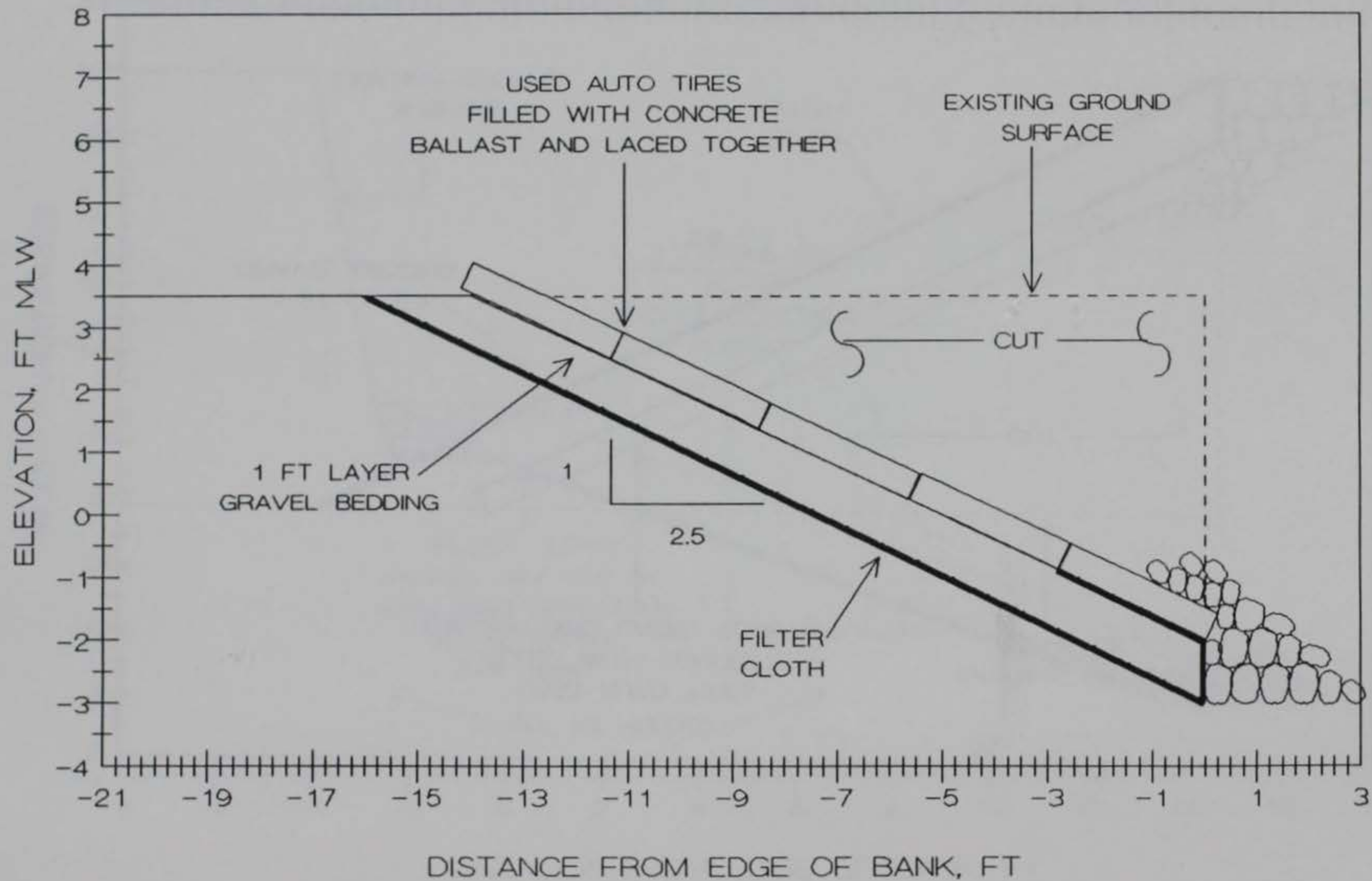

FIGURE 35. USED AUTO TIRE MATTRESS REVETMENT PROPOSED FOR SITE 10

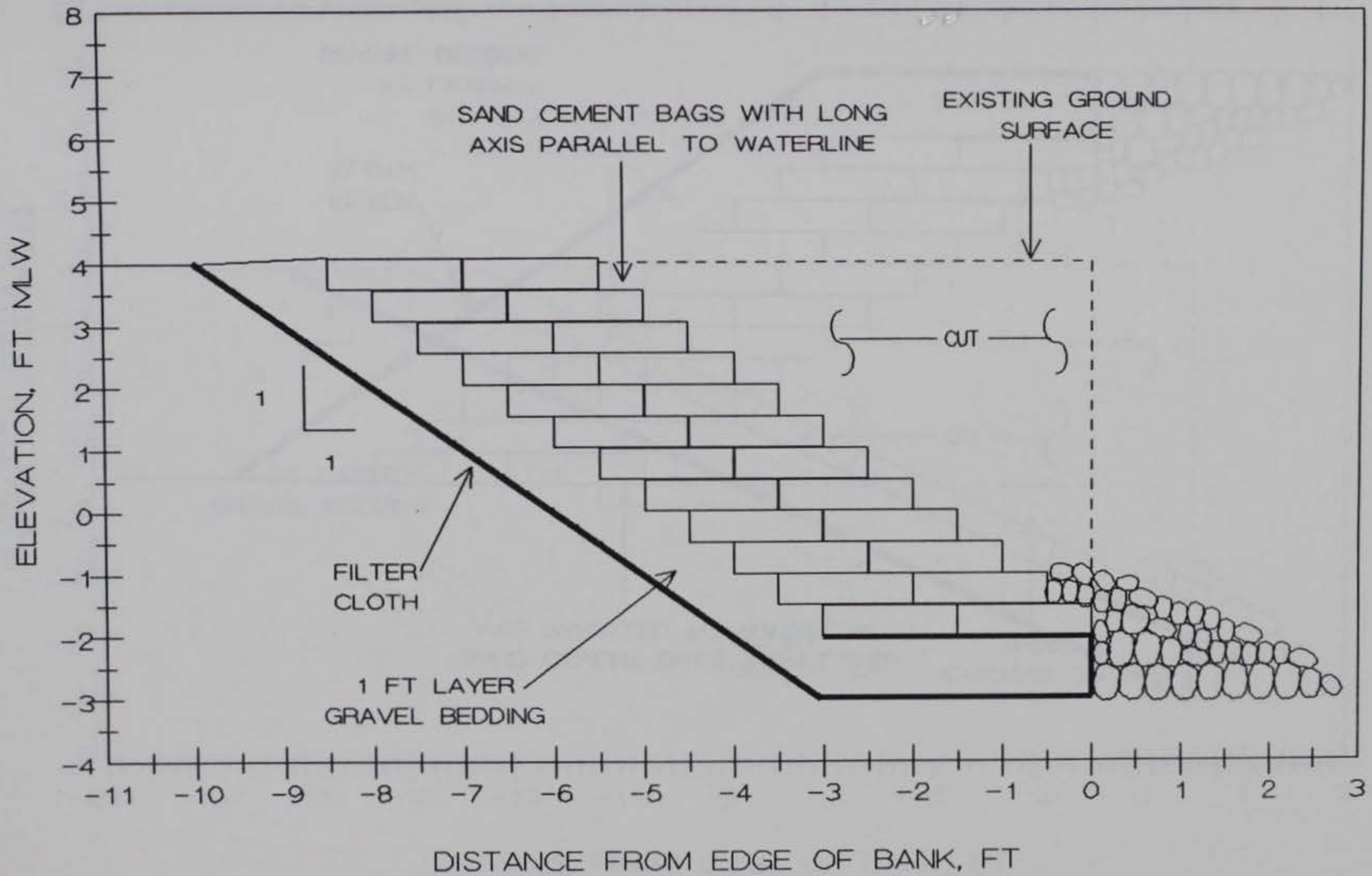

FIGURE 36. SAND-CEMENT SACK REVETMENT PROPOSED FOR SITE 9

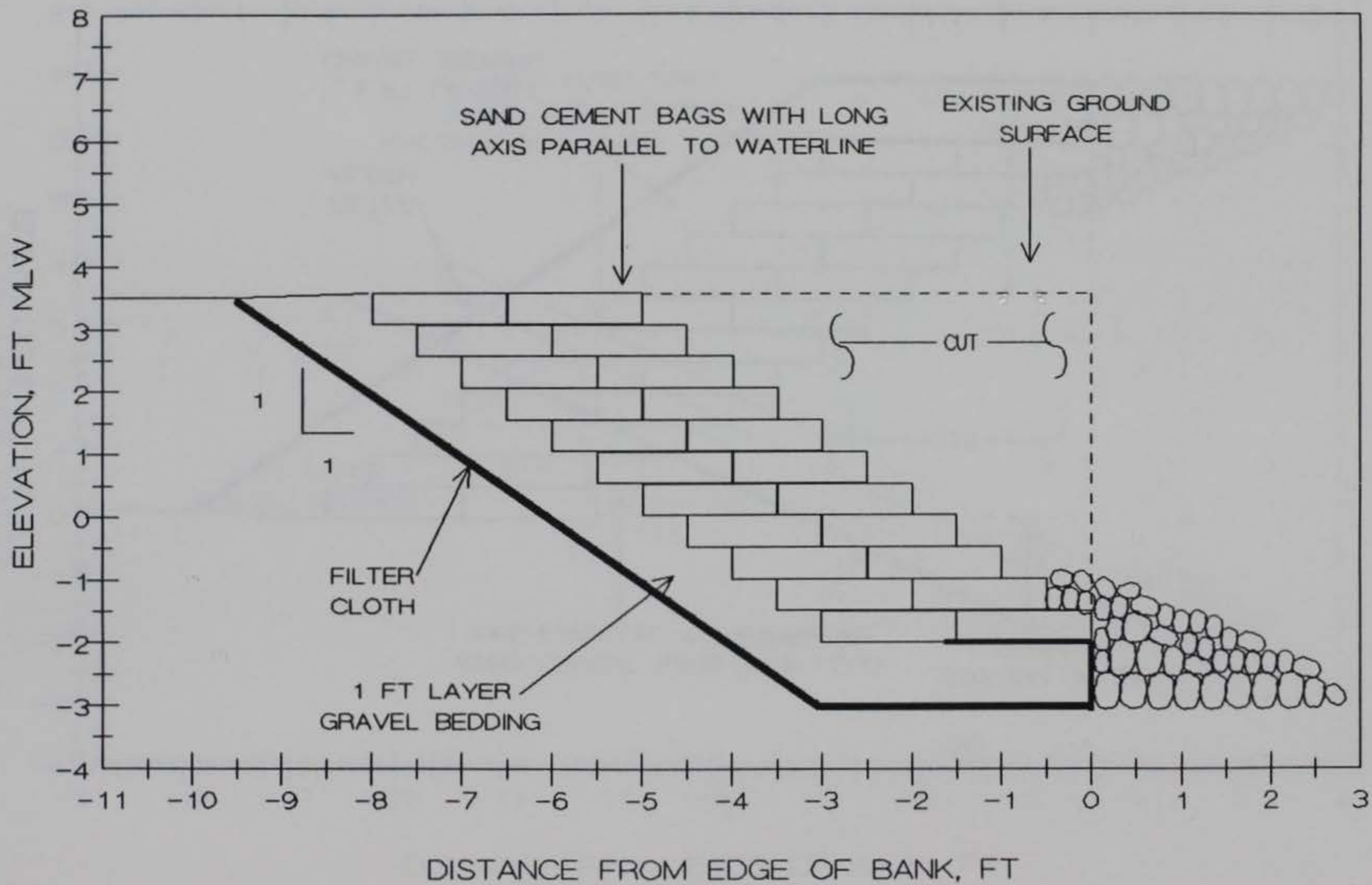

FIGURE 37. SAND-CEMENT SACK REVETMENT PROPOSED FOR SITE 10

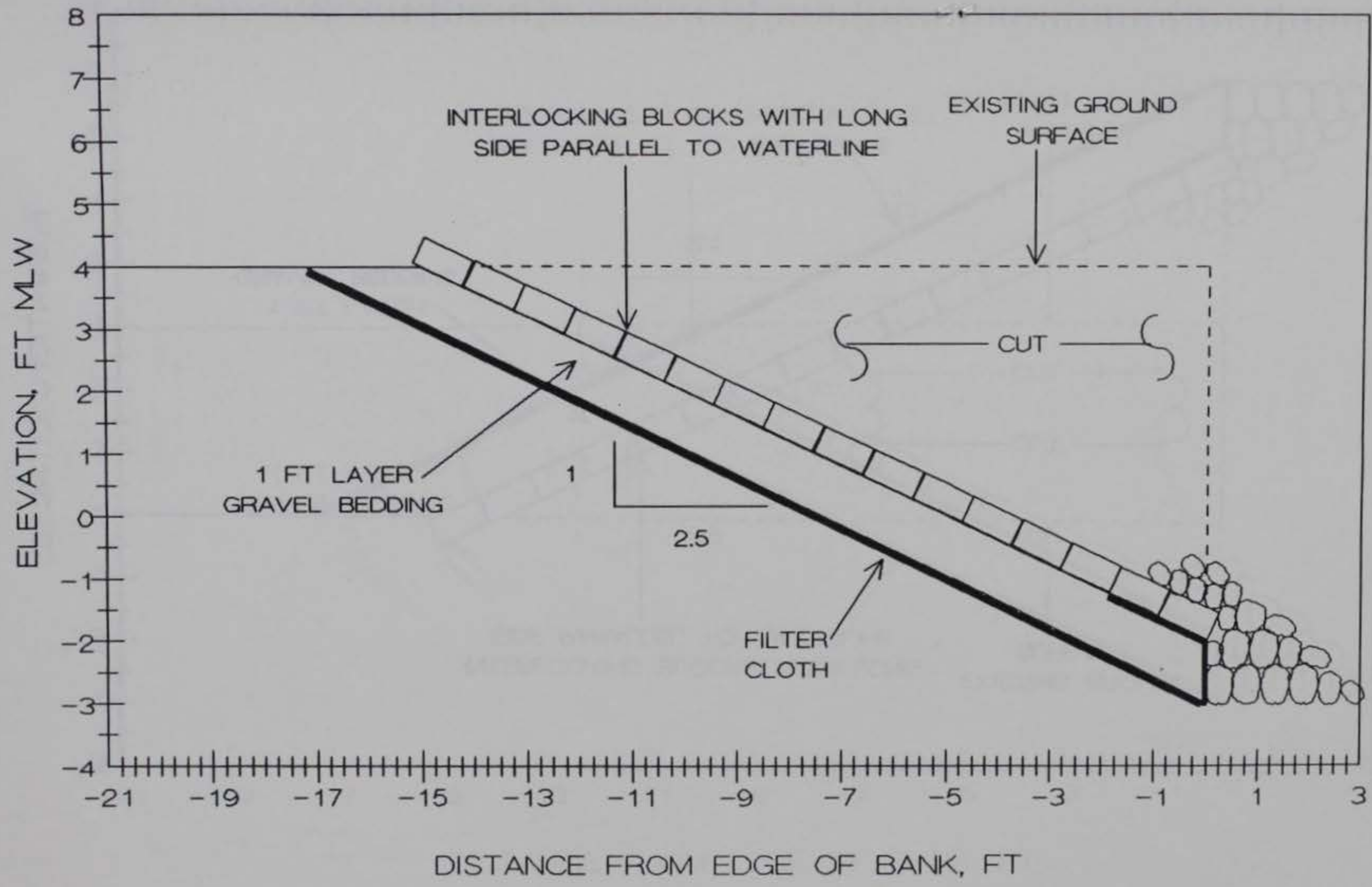

FIGURE 38. INTERLOCKING CONCRETE BLOCK REVETMENT PROPOSED FOR SITE 2

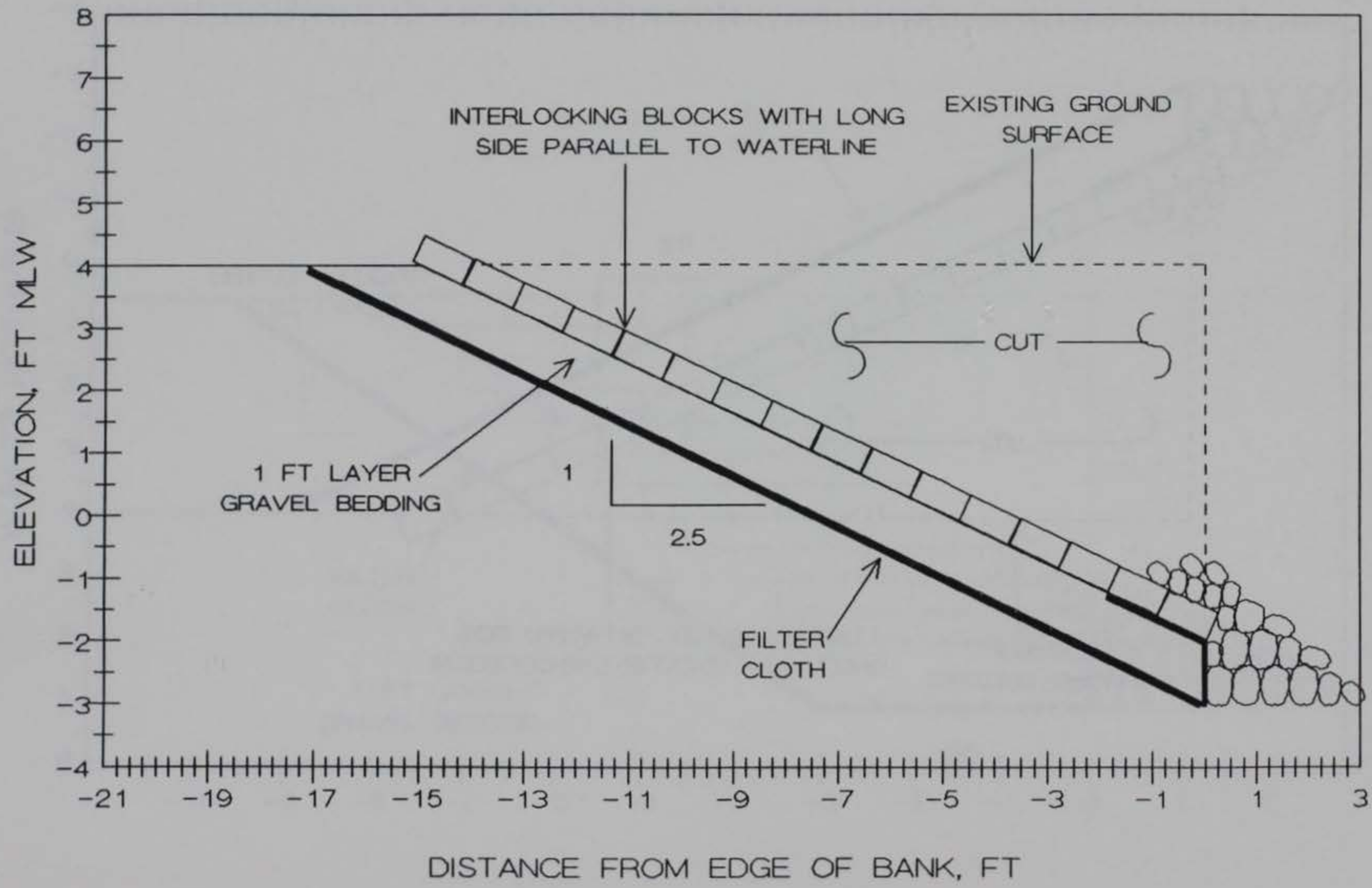

FIGURE 39. INTERLOCKING CONCRETE BLOCK REVETMENT PROPOSED FOR SITE 2A

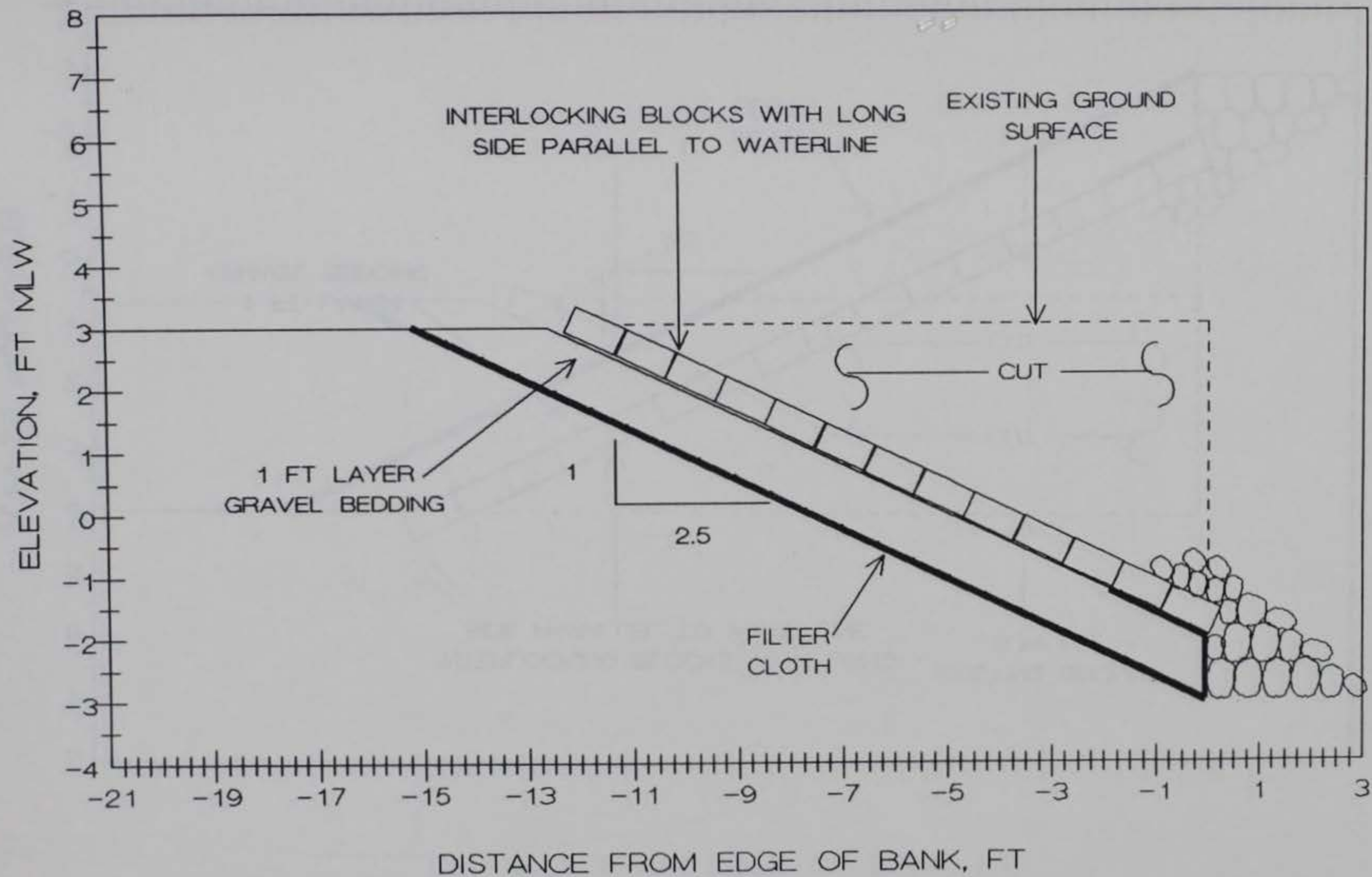

FIGURE 40. INTERLOCKING CONCRETE BLOCK REVETMENT PROPOSED FOR SITE 8

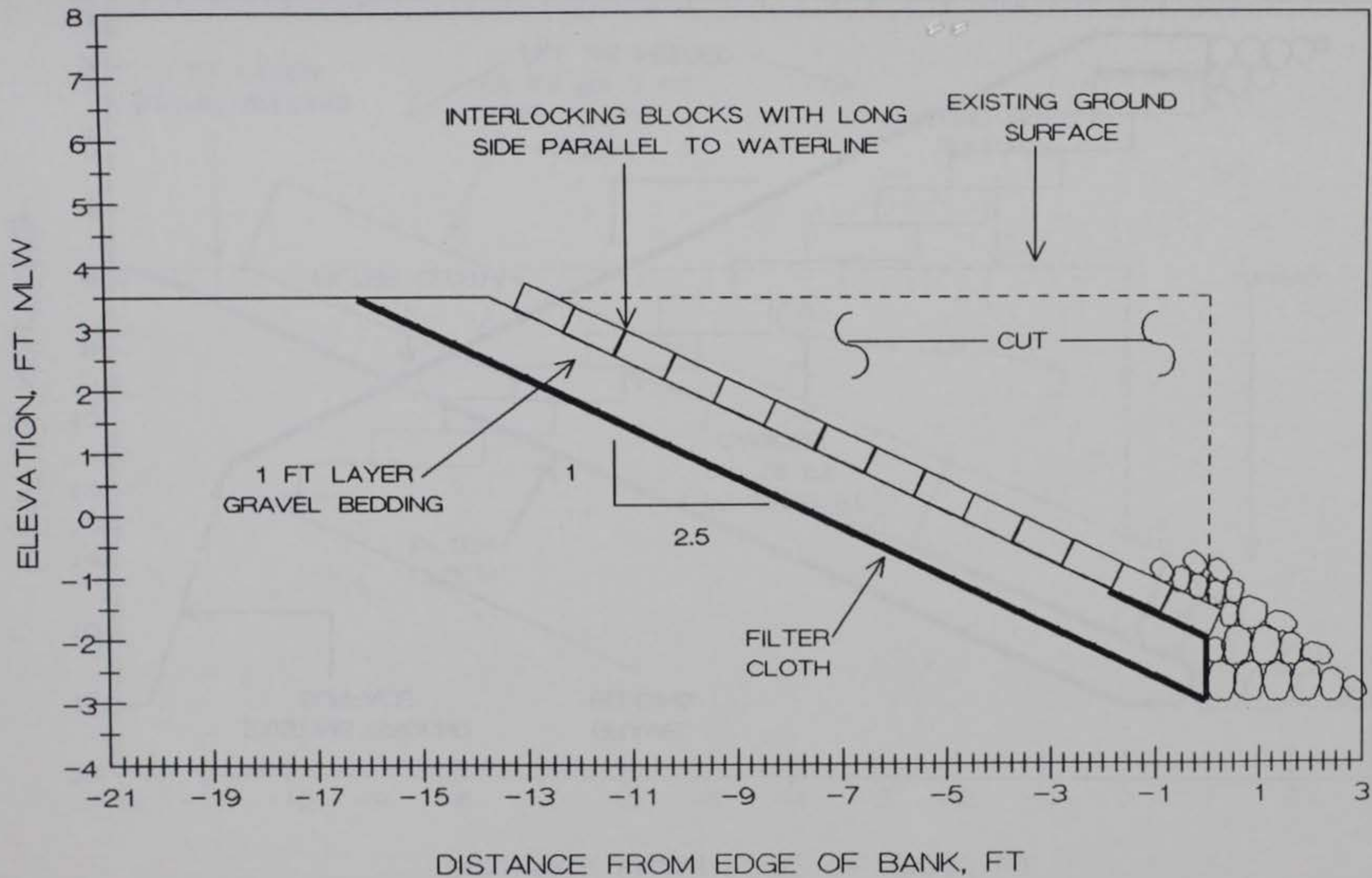

FIGURE 42. INTERLOCKING CONCRETE BLOCK REVETMENT PROPOSED FOR SITE 10

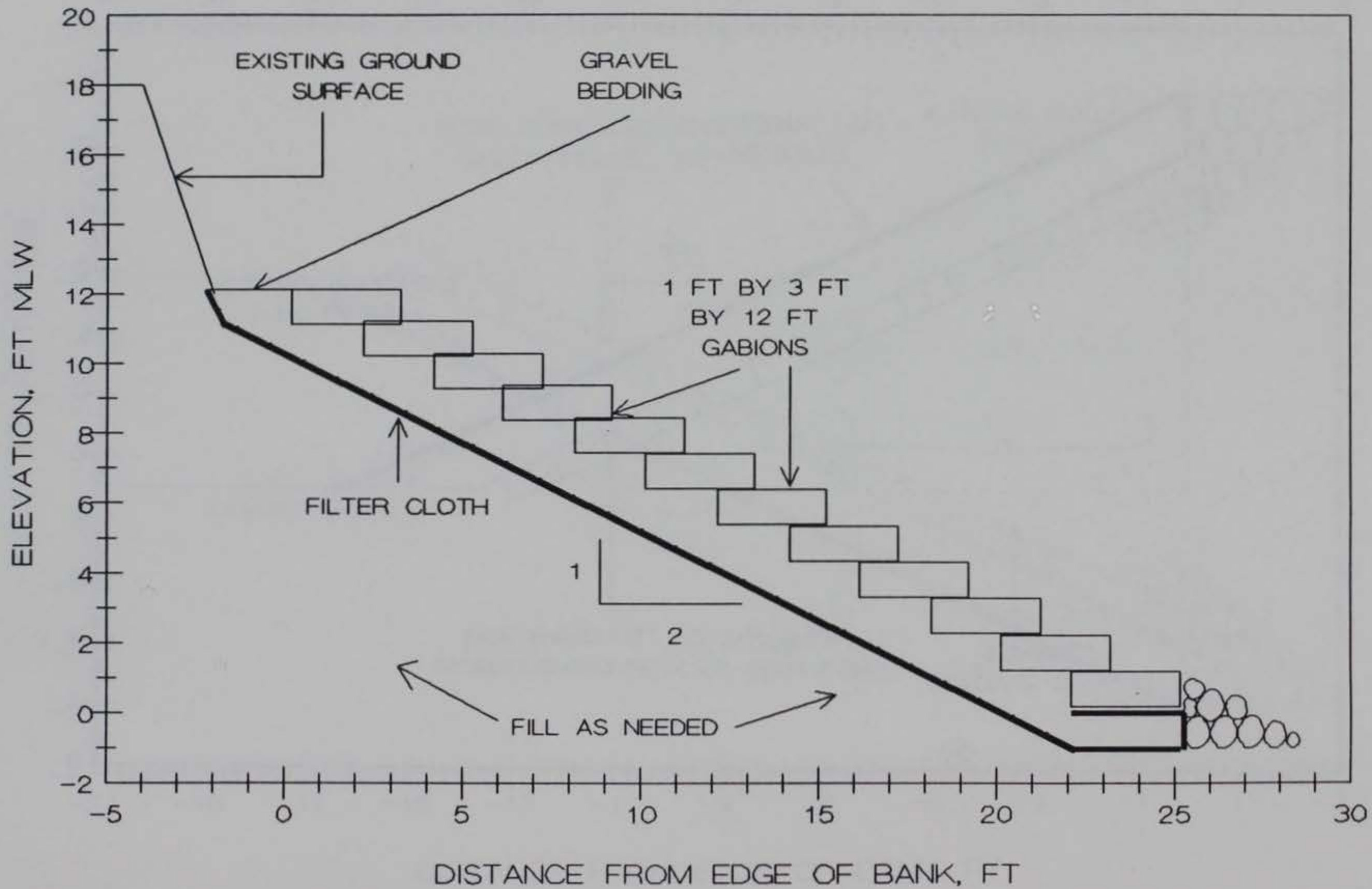

FIGURE 43. GABION REVETMENT PROPOSED FOR SITE 1

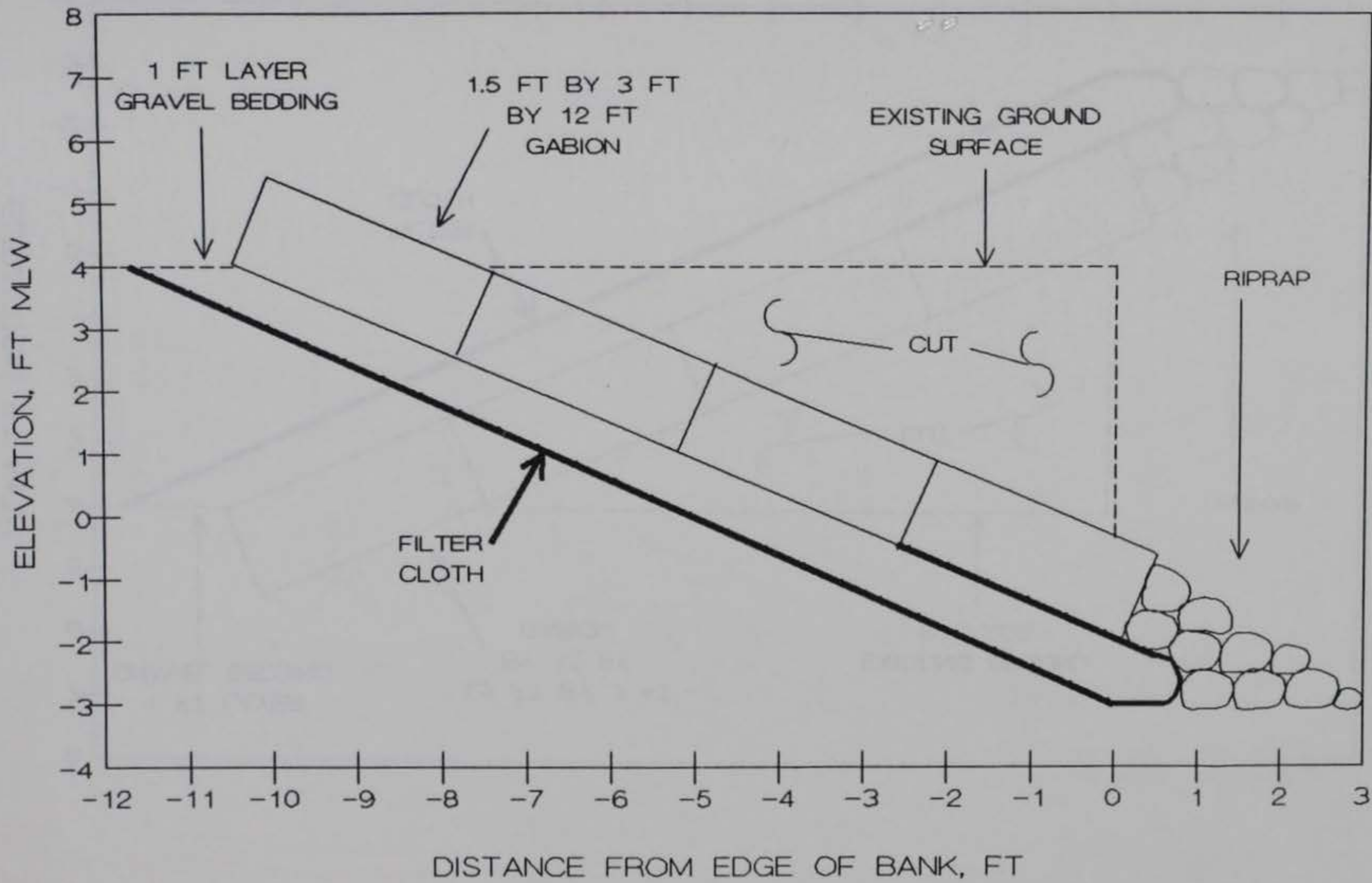

FIGURE 44. GABION REVETMENT PROPOSED FOR SITE 2

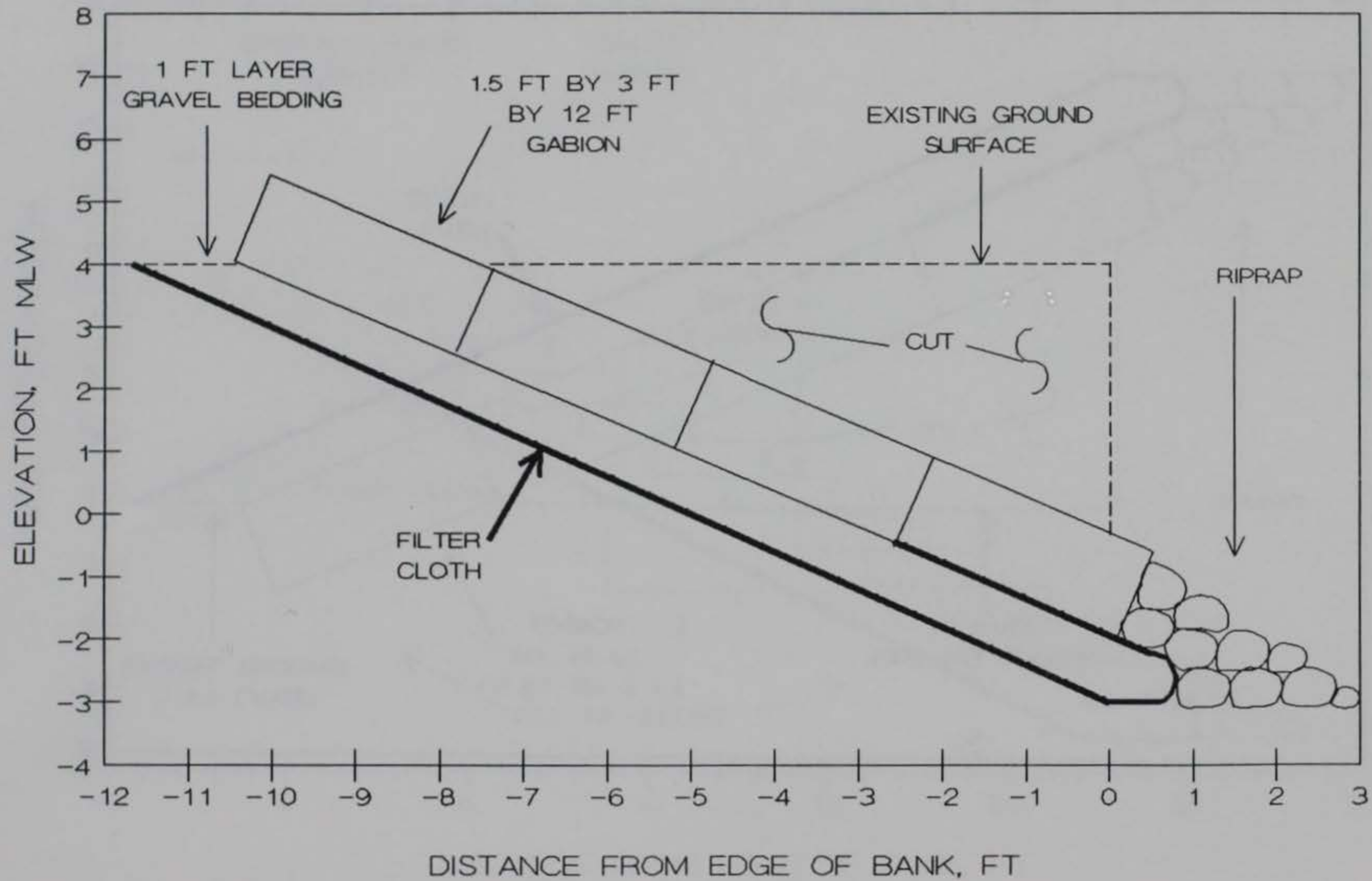

FIGURE 45. GABION REVETMENT PROPOSED FOR SITE 2A

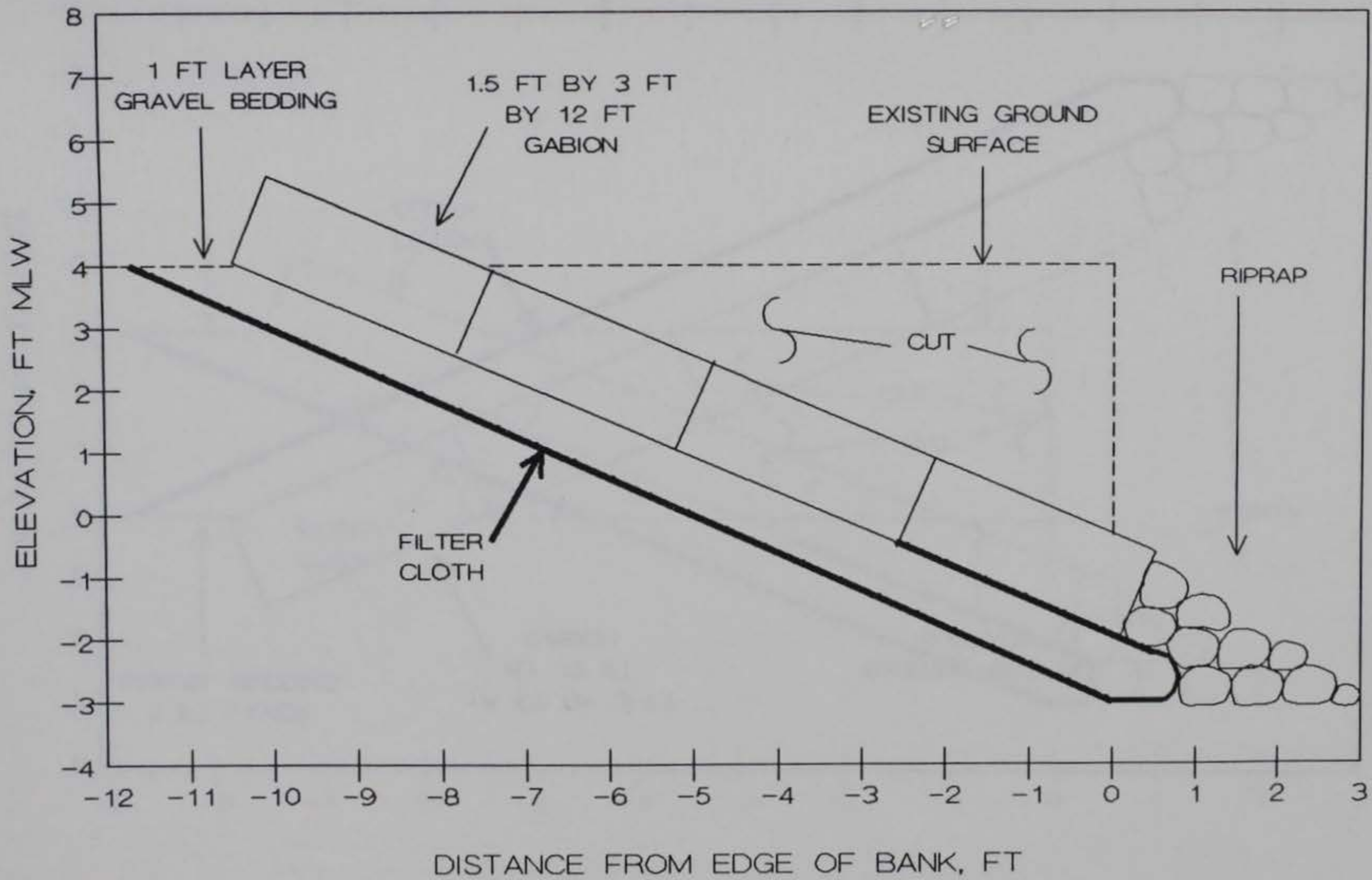

FIGURE 46. GABION REVETMENT PROPOSED FOR SITE 3

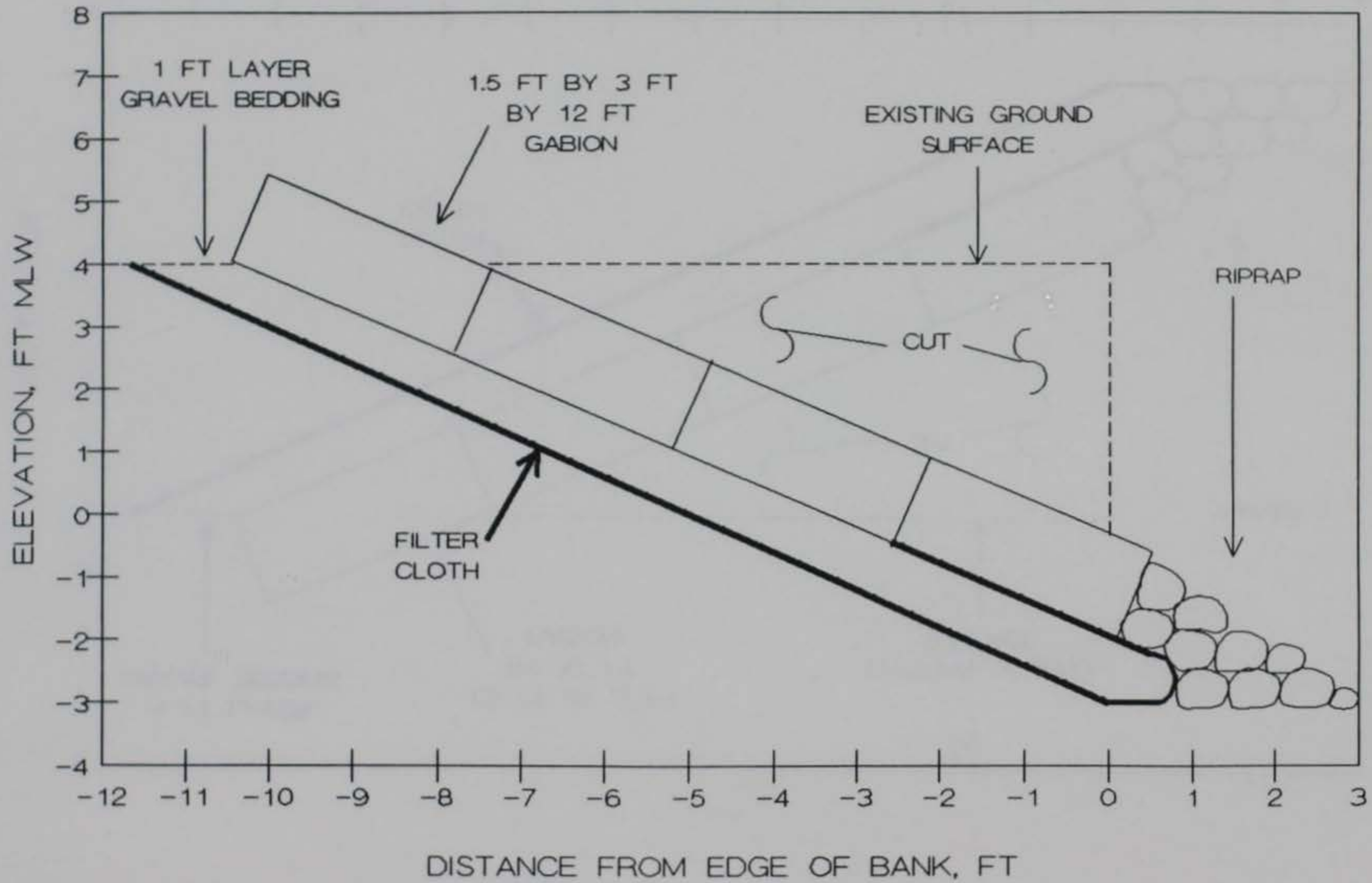

FIGURE 47. GABION REVETMENT PROPOSED FOR SITE 4

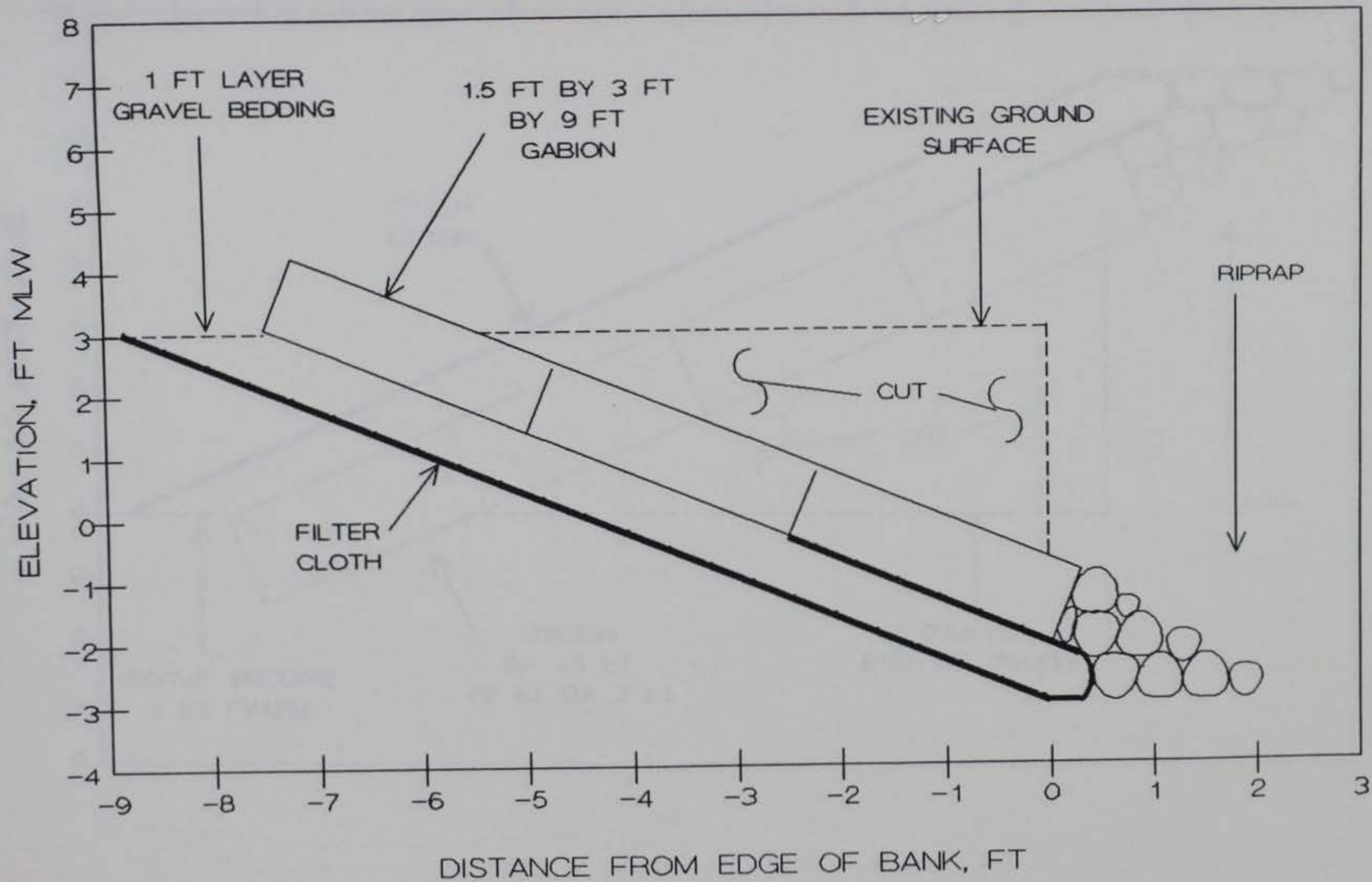

FIGURE 48. GABION REVETMENT PROPOSED FOR SITE 6

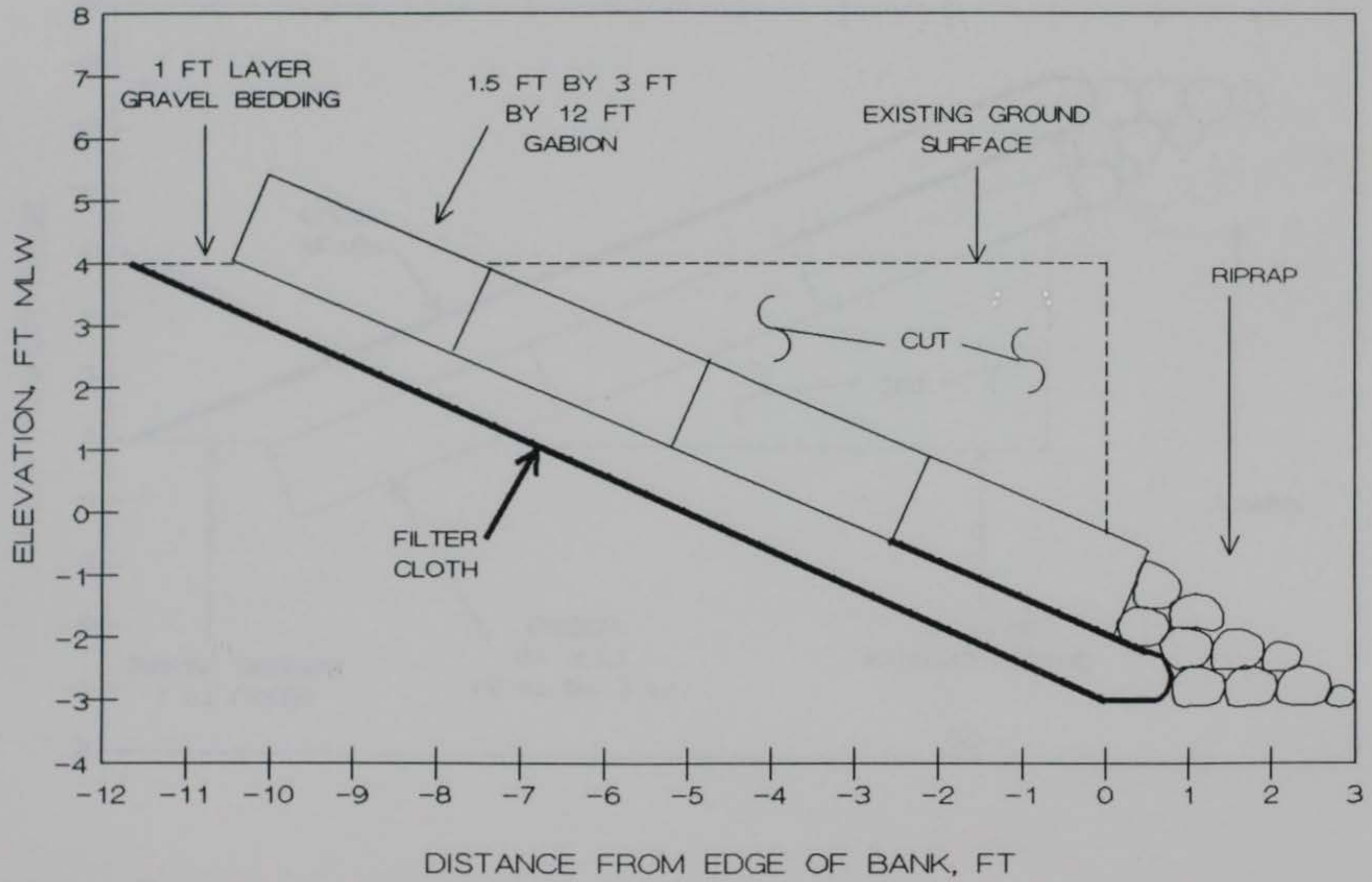

FIGURE 49. GABION REVETMENT PROPOSED FOR SITE 7

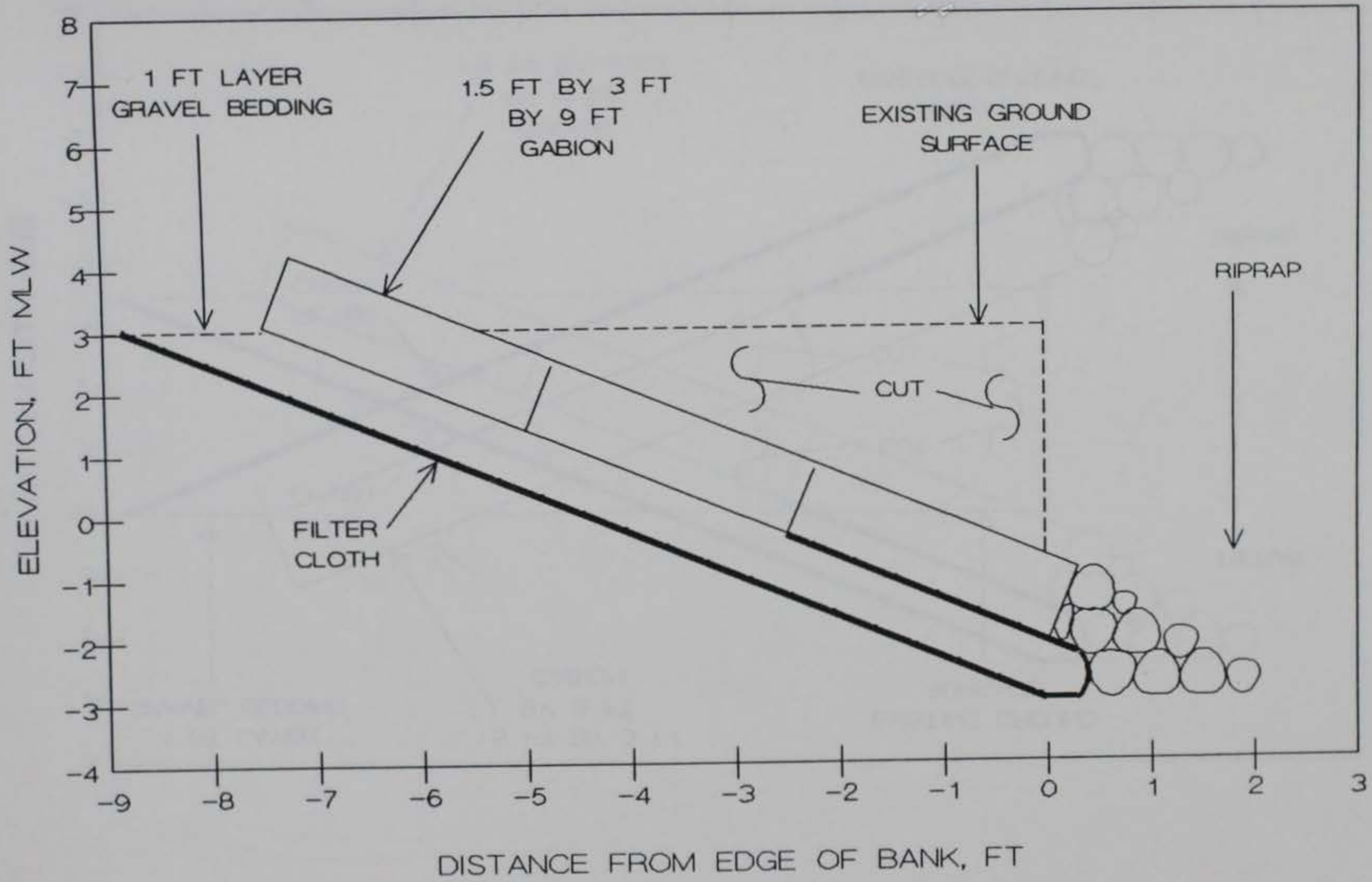

FIGURE 50. GABION REVETMENT PROPOSED FOR SITE 8

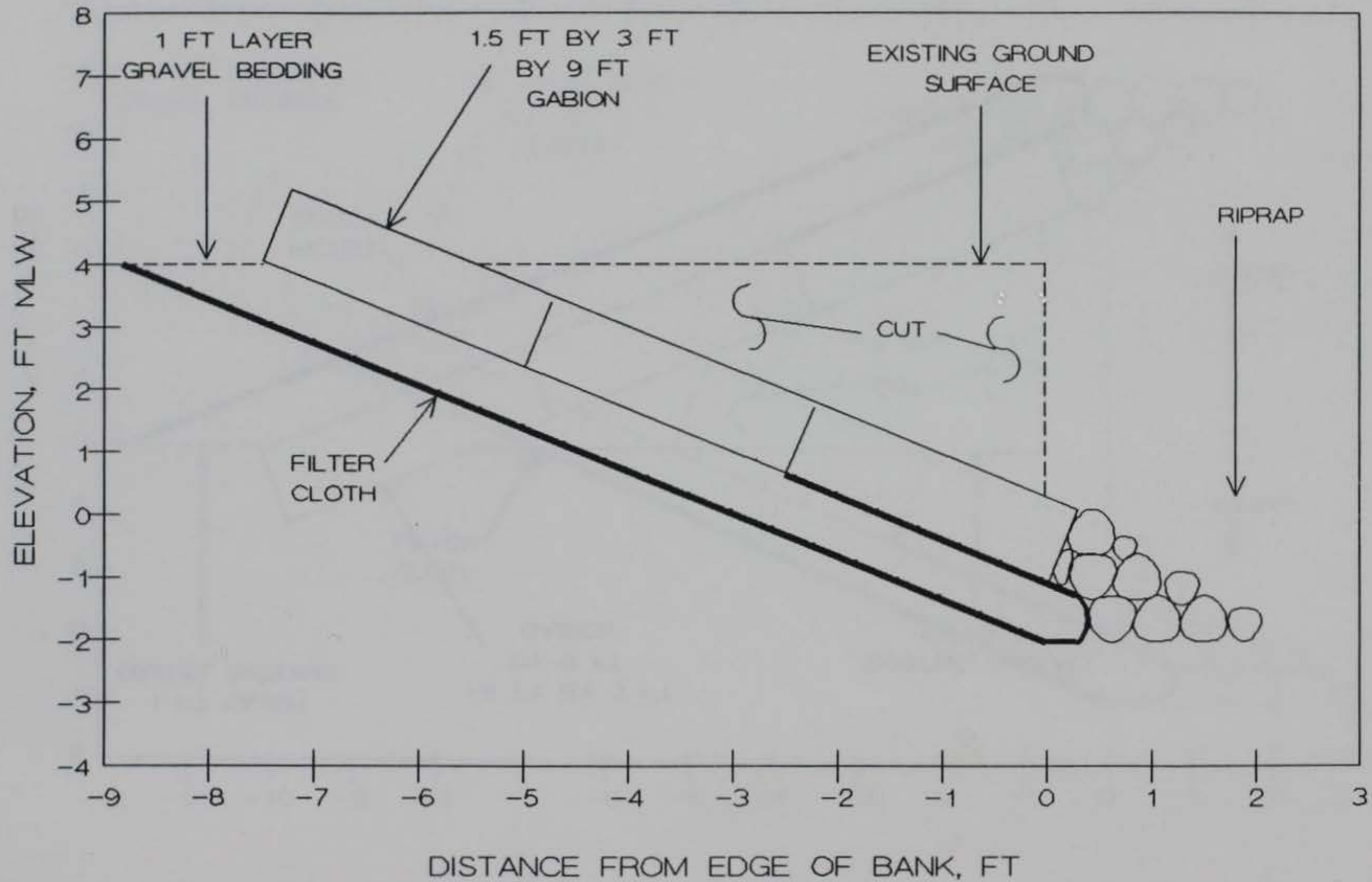

FIGURE 51. GABION REVETMENT PROPOSED FOR SITE 9

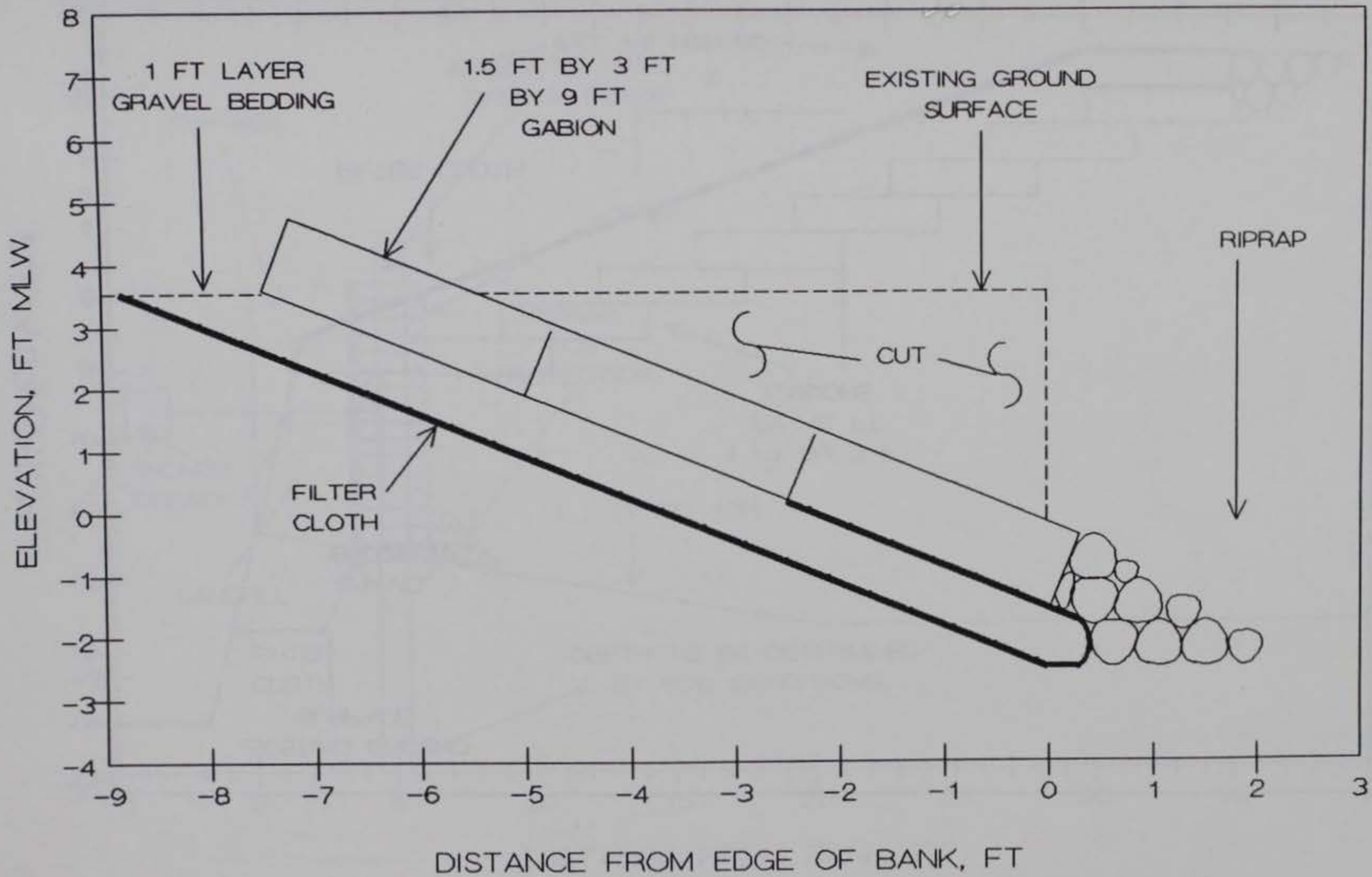

FIGURE 52. GABION REVETMENT PROPOSED FOR SITE 10

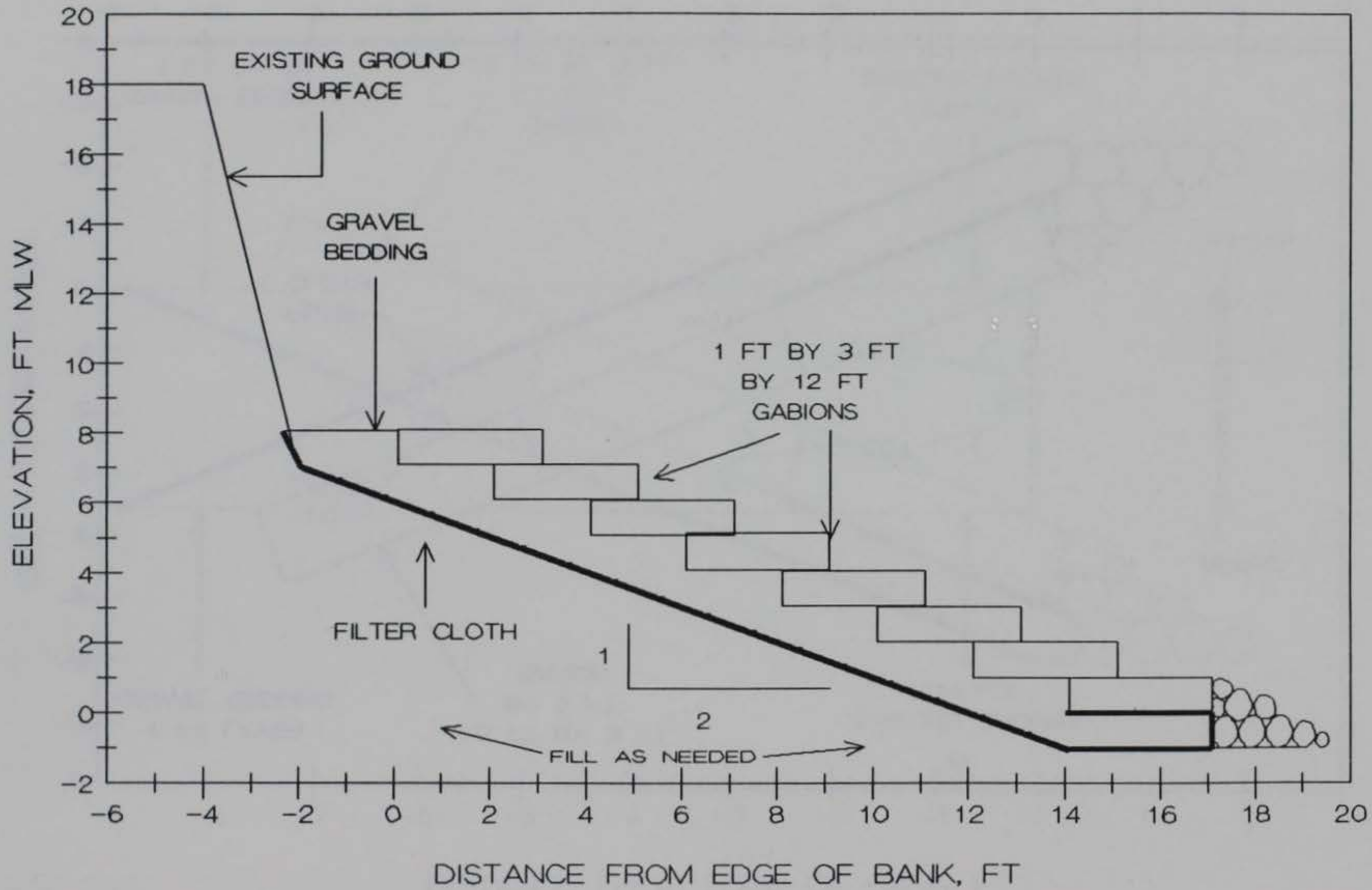

FIGURE 53. GABION REVETMENT PROPOSED FOR SITE 11

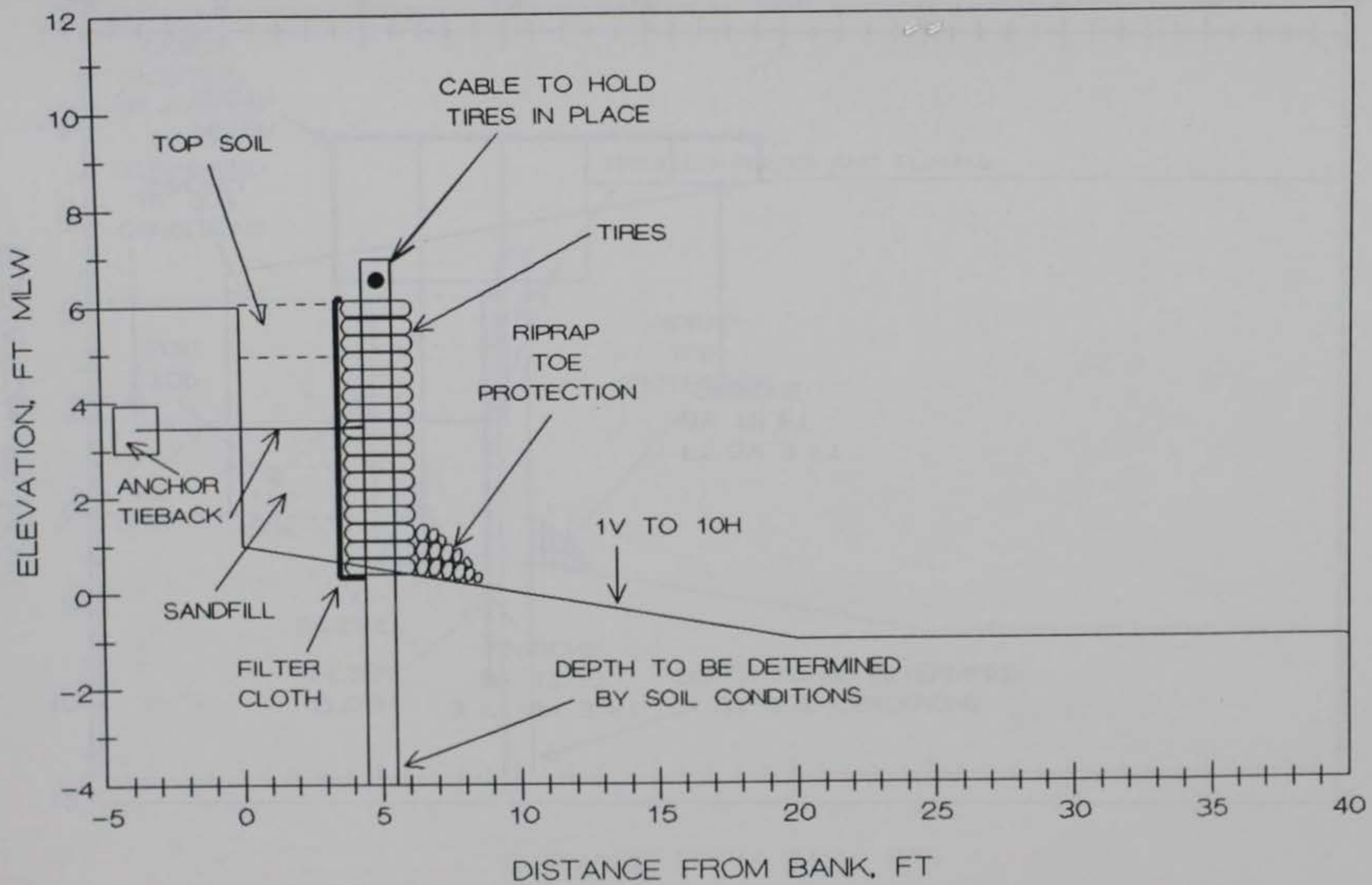

FIGURE 54. USED AUTO TIRE POST BULKHEAD PROPOSED FOR SITE 5

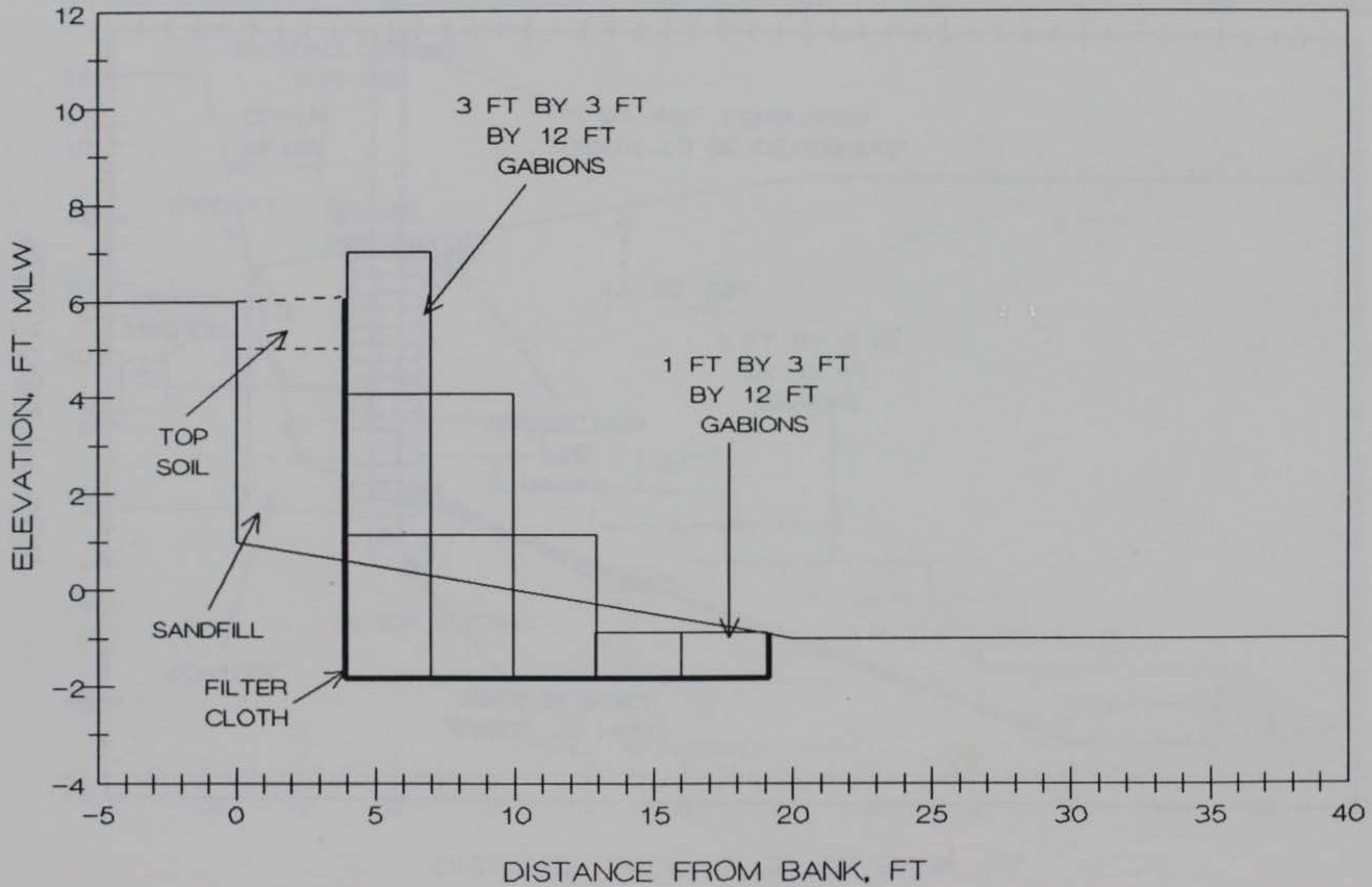

FIGURE 55. GABION BULKHEAD PROPOSED FOR SITE 5

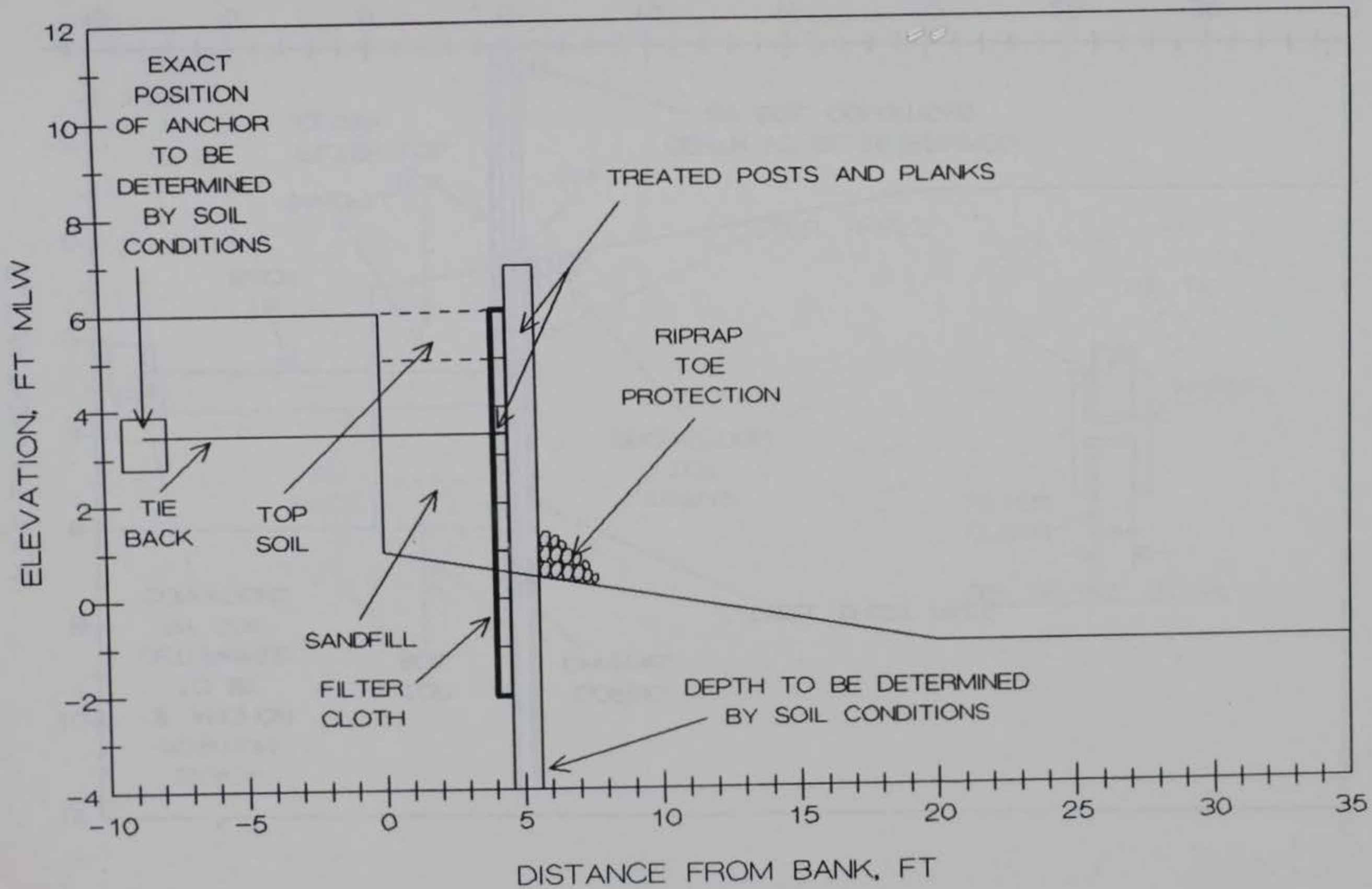

FIGURE 56. TREATED TIMBER BULKHEAD PROPOSED SITE 5

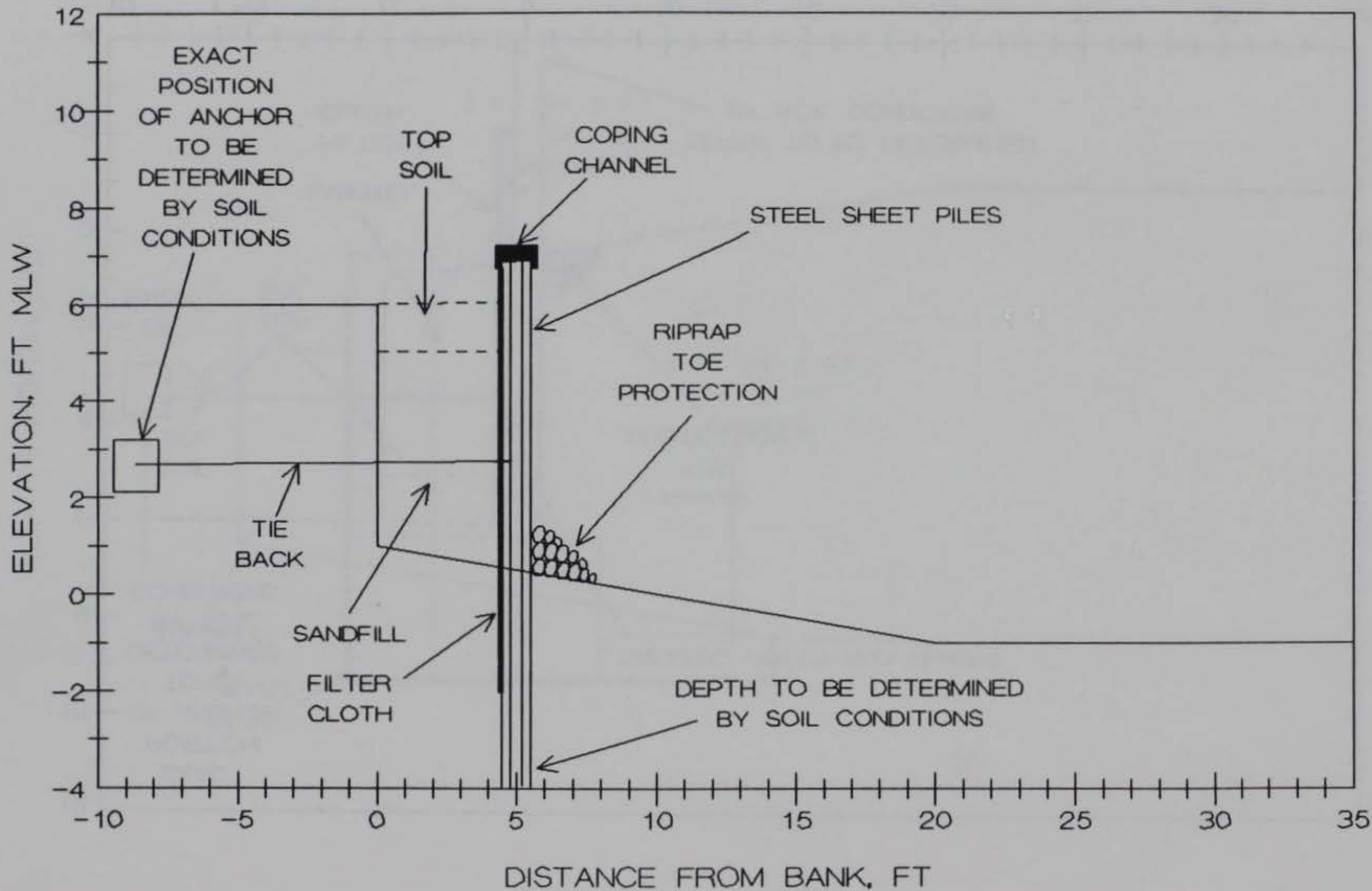

FIGURE 57. STEEL SHEETPILE BULKHEAD PROPOSED FOR SITE 5

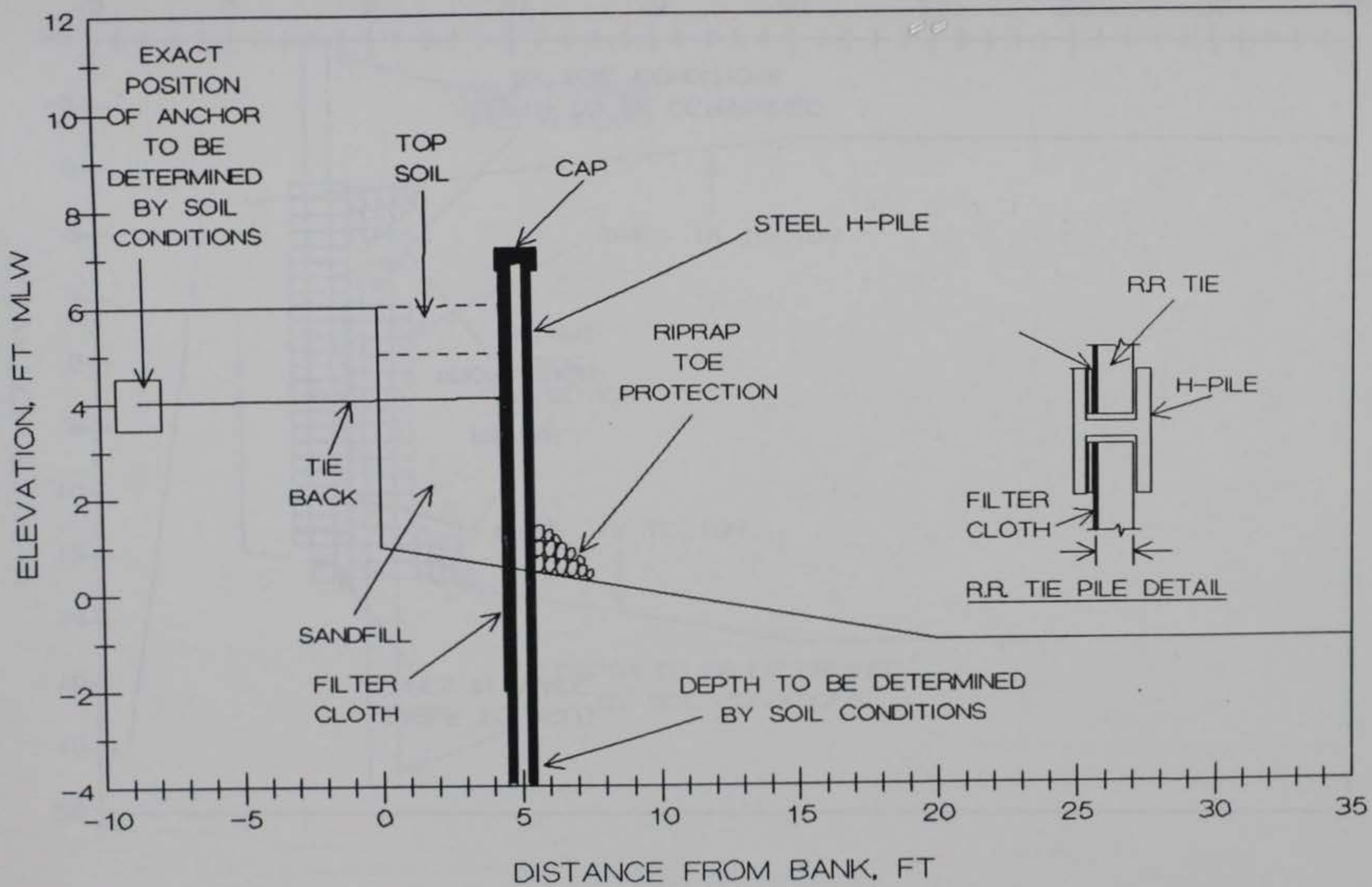

FIGURE 58. STEEL H-PILE AND RAILROAD TIES BULKHEAD PROPOSED FOR SITE 5

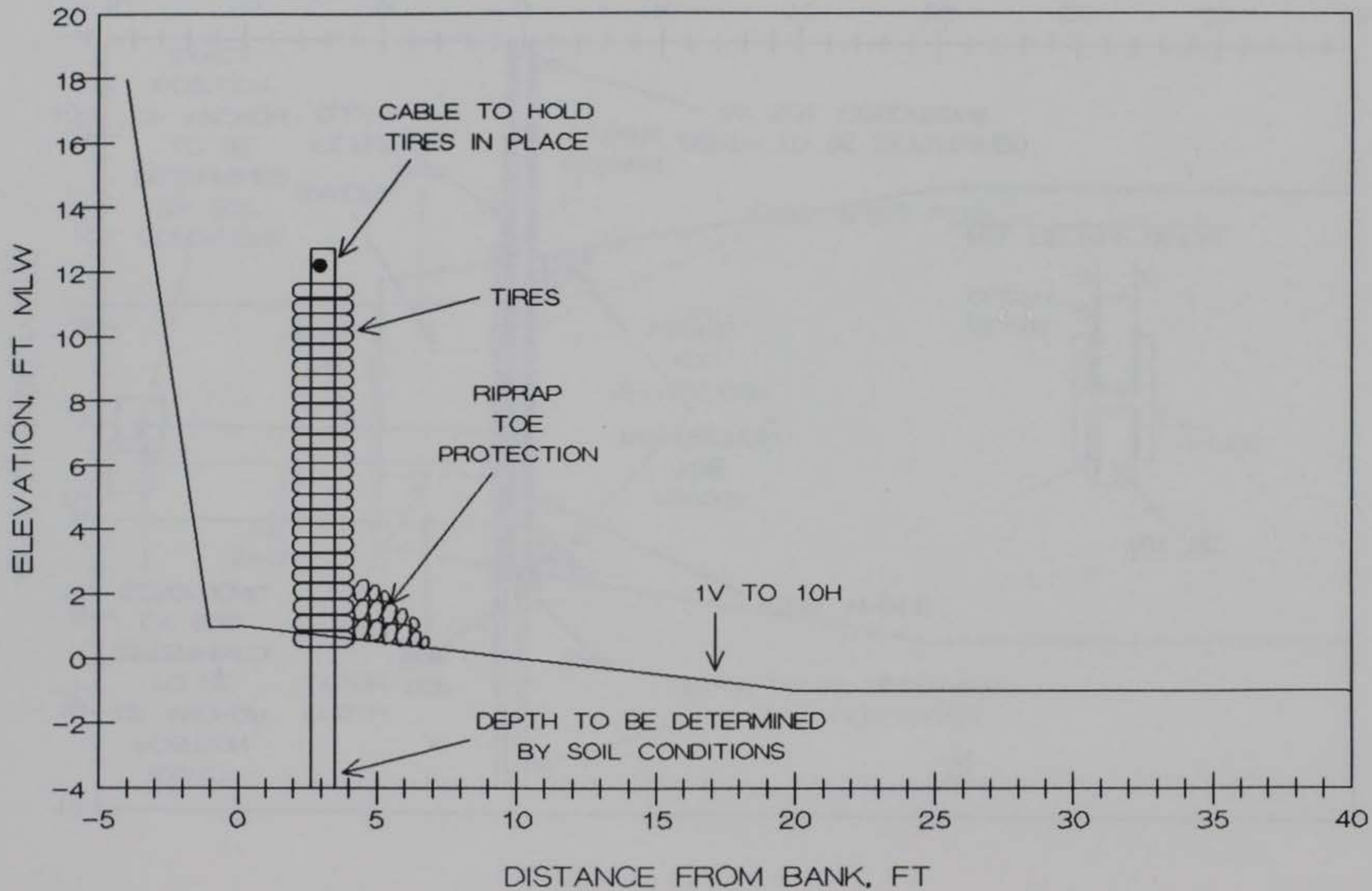

FIGURE 59. USED AUTO TIRE POST RETARD PROPOSED FOR SITE 1

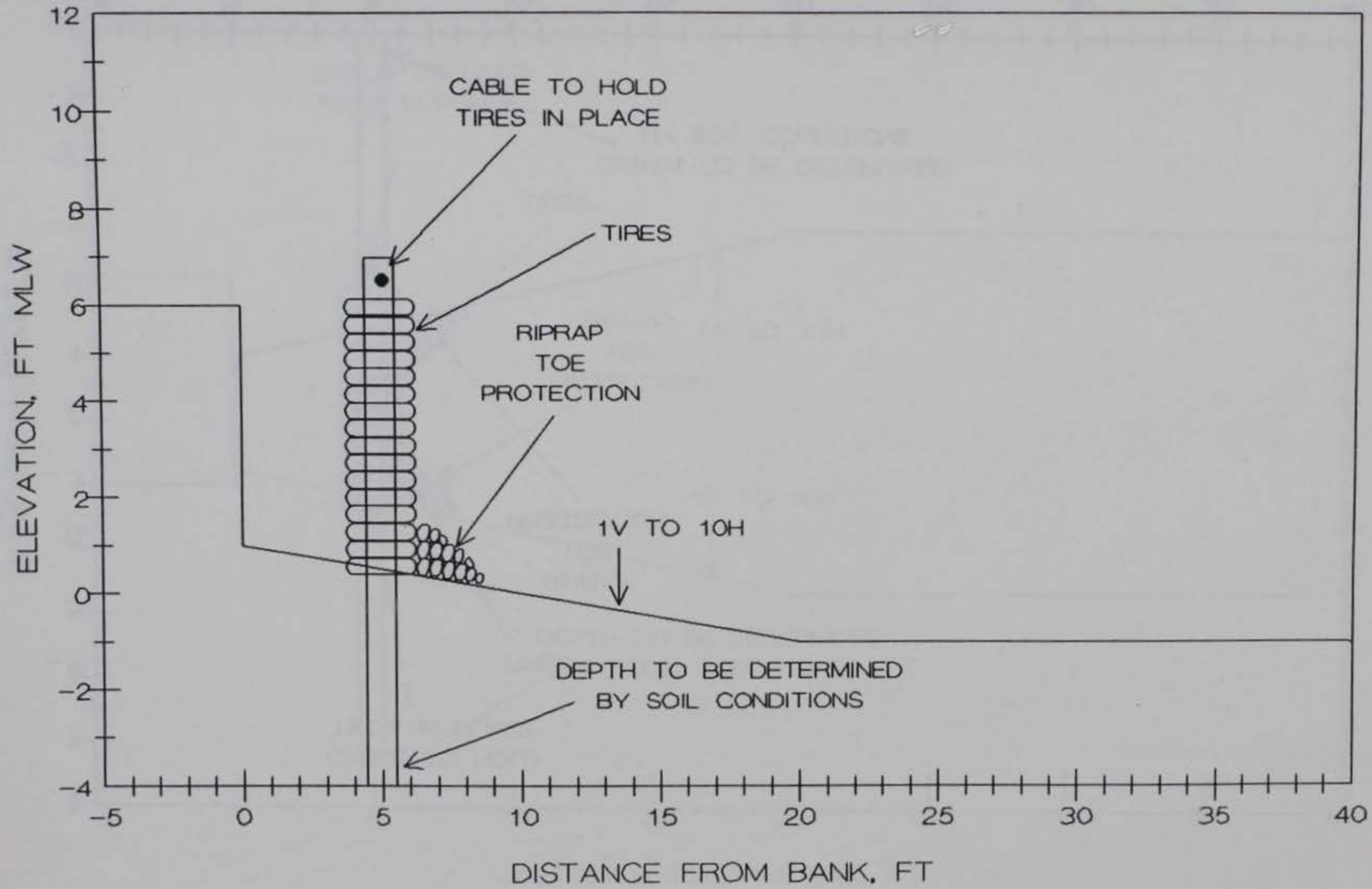

FIGURE 60. USED AUTO TIRE POST RETARD PROPOSED FOR SITE 5

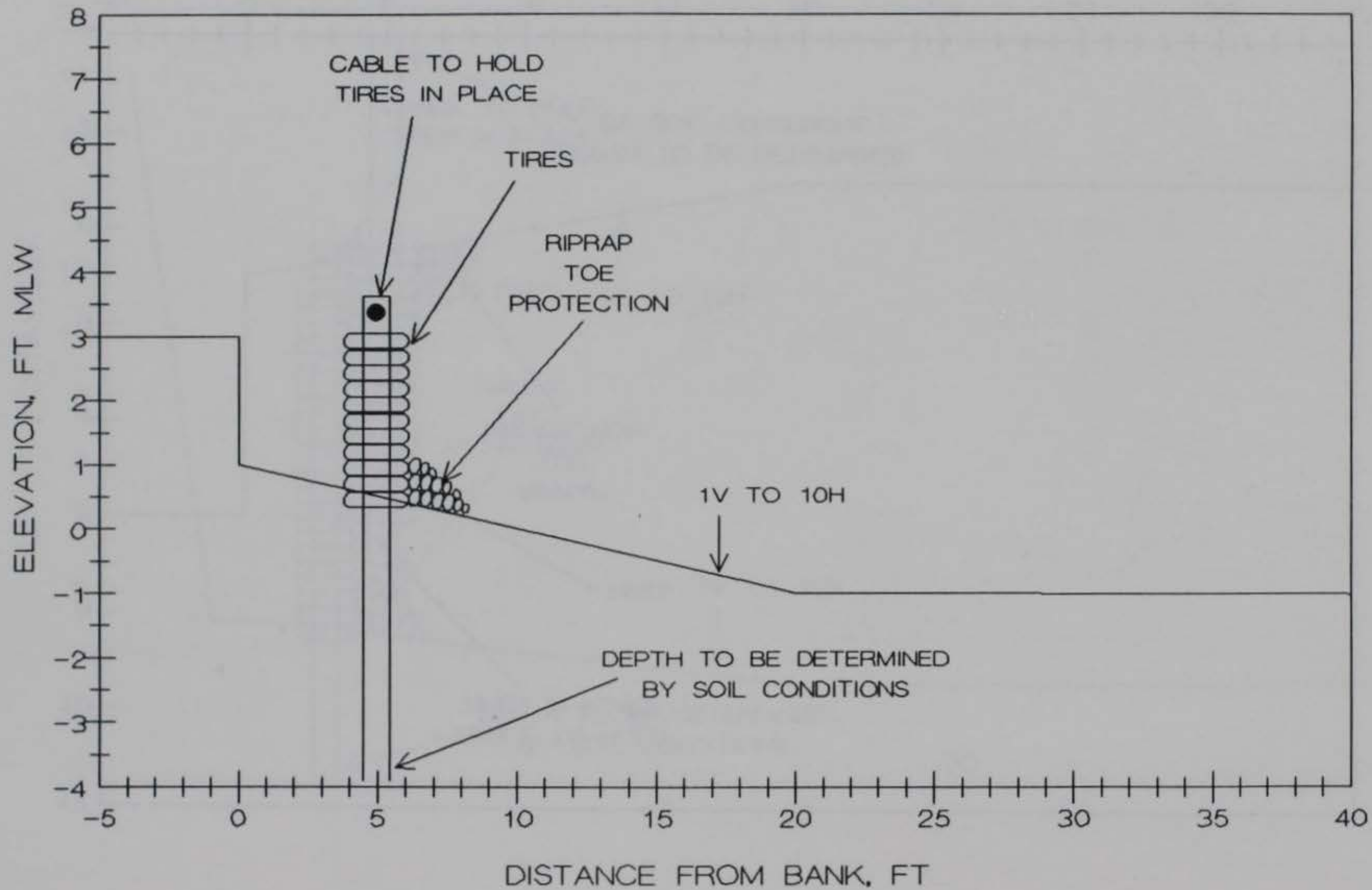

FIGURE 61. USE AUTO TIRE POST RETARD PROPOSED FOR SITE 6

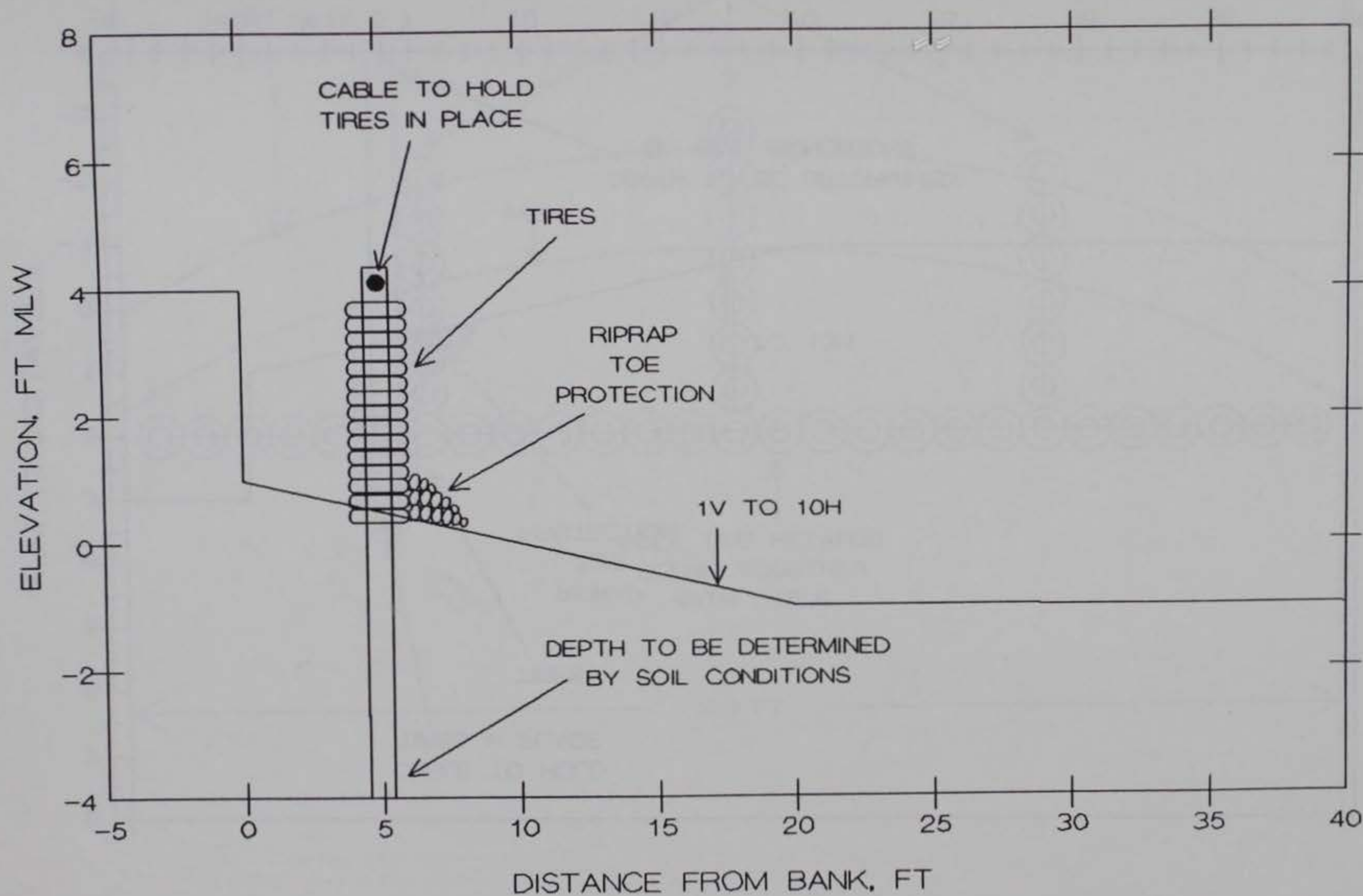

FIGURE 62. USED AUTO TIRE POST RETARD PROPOSED FOR SITE 7

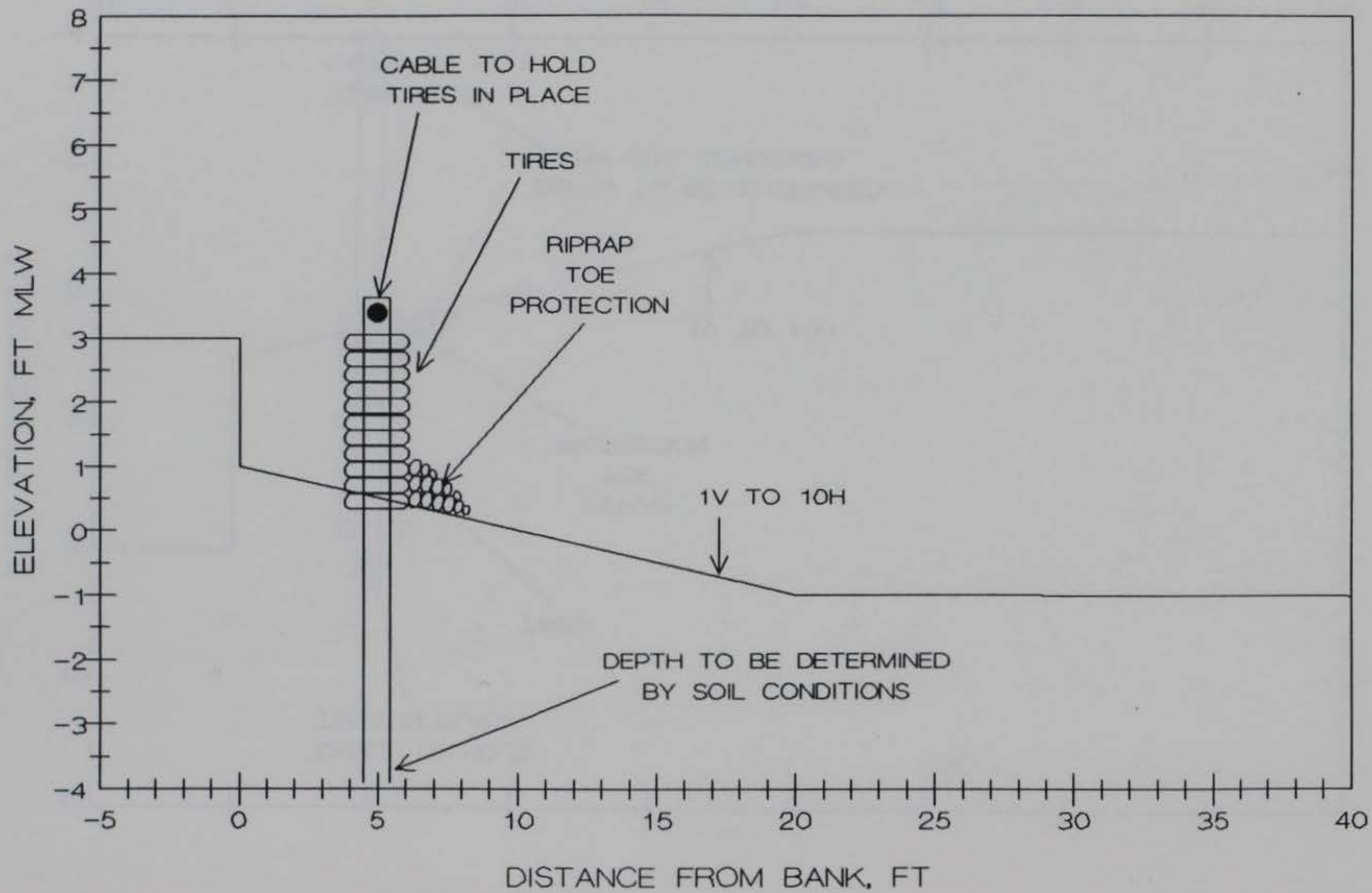

FIGURE 63. USED AUTO TIRE POST RETARD PROPOSED FOR SITE 8

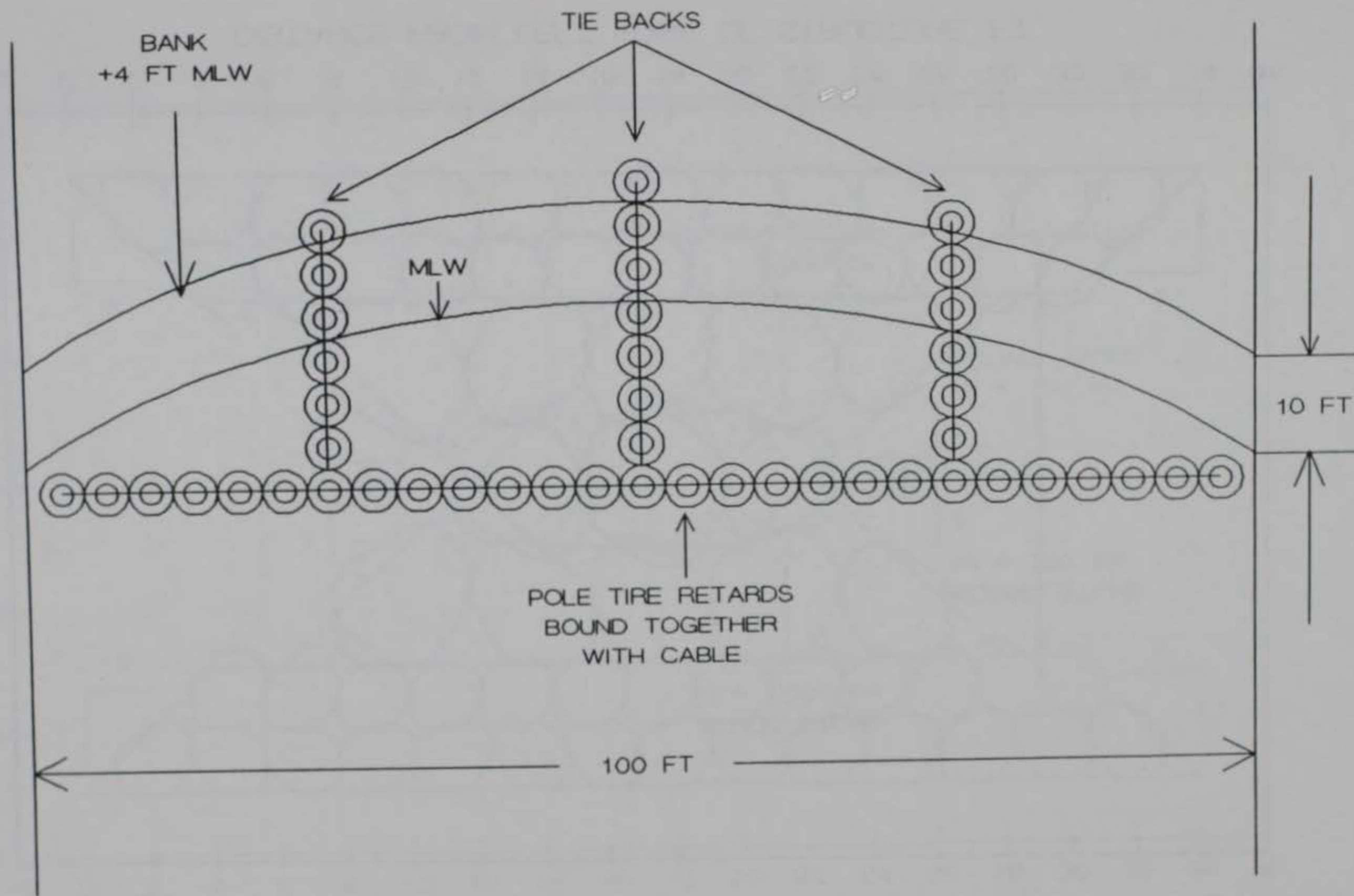

FIGURE 64. PLAN VIEW OF TYPICAL USED AUTO TIRE POST RETARD INSTALLATION

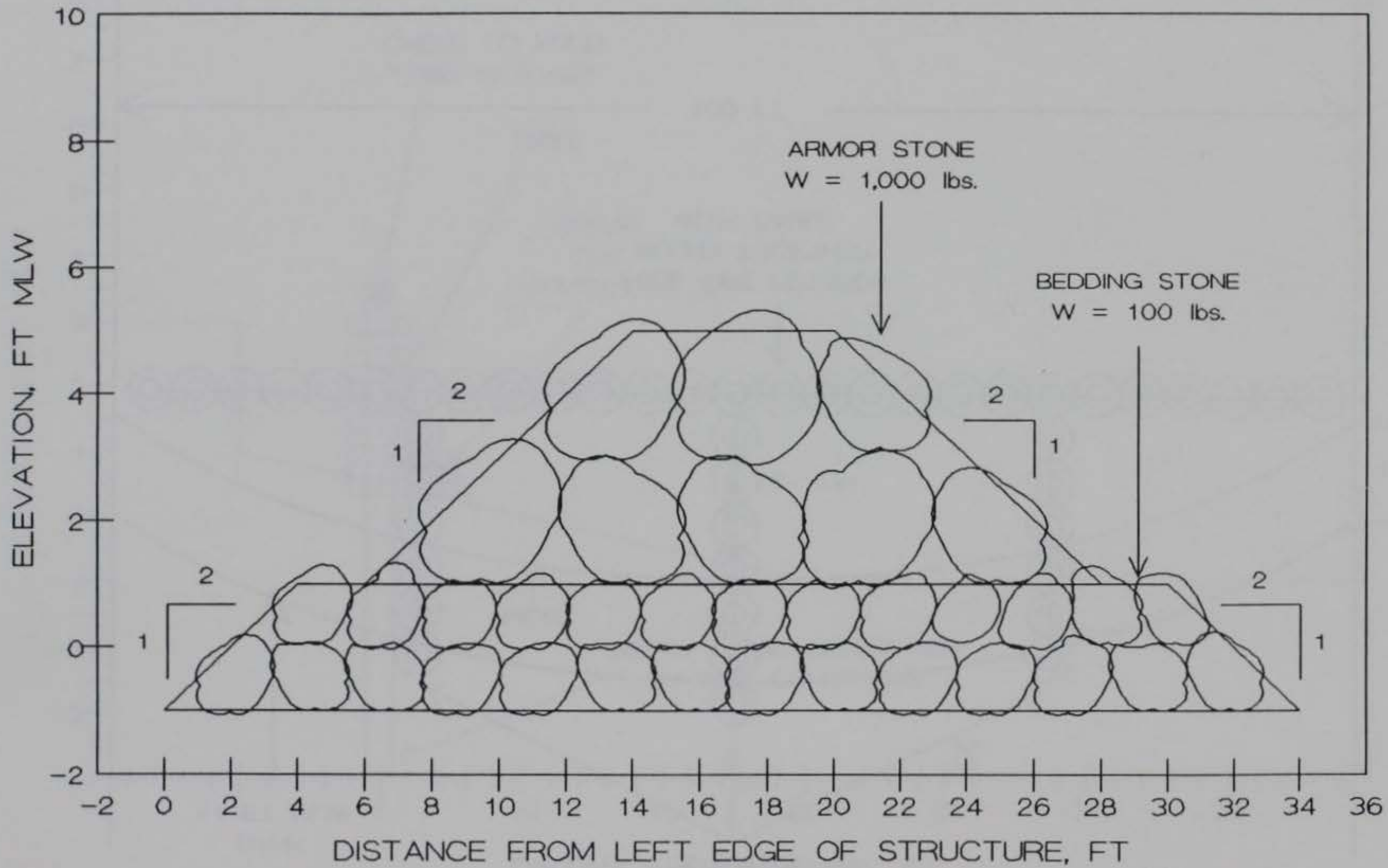

FIGURE 65. SEGMENTED LOW CRESTED BREAKWATER PROPOSED FOR SITE 3

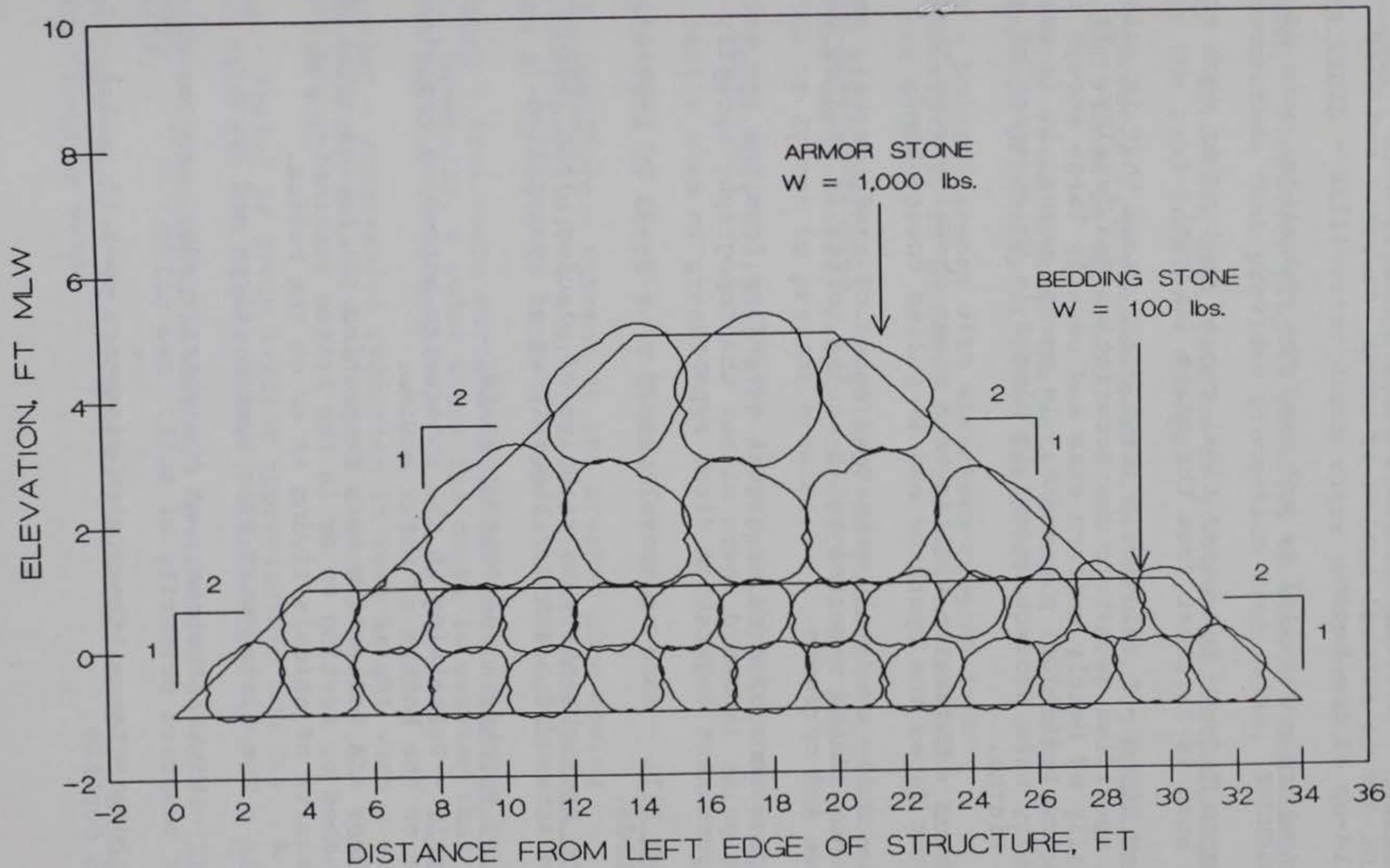

FIGURE 66. SEGMENTED LOW CRESTED BREAKWATER PROPOSED FOR SITE 4

GLOSSARY

Accretion - Accumulation of sand or other beach material at a point due to natural action of waves, currents and wind. A build-up of the beach.

Alongshore - Parallel to and near the shoreline; same as LONGSHORE.

Apogean Tides - Decreased tidal ranges that occur each month when the moon is farthest from the earth (apogee).

Armor Stone - A relatively large quarystone that is selected to fit specified geometric characteristics and density. It is usually of nearly uniform size and usually large enough to require individual placement. In normal cases, it is used as primary wave protection and is placed in thicknesses of at least two widths.

Backhoe - Excavator similar to a power shovel except that the bucket faces the operator and is pulled toward him.

Bar - Fully or partly submerged mound of sand, gravel, or other unconsolidated material built on the bottom in shallow water by waves and currents.

Beach - Zone of sand or gravel extending from the low water line to a point landward where either the topography abruptly changes or permanent vegetation first appears.

Beach Fill - Sand or gravel placed on a beach by mechanical methods.

Beach Nourishment - The practice of placing clean, sandy sediment onto an eroded beach for the purpose of restoration.

Beach, Perched - See PERCHED BEACH.

Benthic - Pertaining to the subaquatic bottom or organisms that live on the bottom of water bodies.

Benthos - A collective term describing (1) bottom organisms attached or resting on or in the bottom sediments, and (2) community of animals living in or on the bottom.

Biota - The living part of a system (flora and fauna).

Bluff - High, steep bank at the water's edge. In common usage, a bank composed primarily of soil. See CLIFF.

Boulders - Large stones with diameters over 10 inches. Larger than COBBLES.

Breaker - A wave as it spills, plunges, or collapses on a shore, natural obstruction, or man-made structure.

Breaker Zone - Area offshore where waves break.

Breaking Depth - Still-water depth where waves break.

Breakwater - Structure aligned parallel to shore, sometimes shore-connected, that provides protection from waves.

Bulkhead - Structure that retains or prevents sliding of land or protects the land from wave damage.

Clay - Extremely fine-grained soil with individual particles less than 0.00015 inch in diameter.

Cliff - High steep bank at the water's edge. In common usage, a bank composed primarily of rock. See BLUFF.

Cobbles - Rounded stones with diameters ranging from approximately 3 to 10 inches. Cobbles are intermediate between GRAVEL and BOULDERS.

Concrete Block Revetment - Regularly cavitated interconnected (sometimes cable-stayed) precast concrete blocks placed on a shoreline or filter to prevent erosion.

Crest - Upper edge or limit of a shore protection structure.

Culm - Single stem of grass.

Current - Flow of water in a given direction.

Current, Longshore - Current in the breaker zone moving essentially parallel to shore and usually caused by waves breaking at an angle to shore. Also called alongshore current.

Deep Water - Area where surface waves are not influenced by the bottom. Generally, a point where the depth is greater than one-half the surface wavelength.

Diffraction - Progressive reduction in wave height when a wave spreads into the shadow zone behind a barrier after the wave has passed its end.

Diurnal - Period or cycle lasting approximately one day. A diurnal tide has one high and one low in each cycle.

Downdrift - Direction of alongshore movement of littoral materials.

Dune - Hill, bank, bluff, ridge, or mound of loose, wind-blown material, usually sand.

Duration - The length of time the wind blows in nearly the same direction across a FETCH (generating area).

Ebb Tide - Part of the tidal cycle between high water and the next low. The falling tide.

Equatorial Tides - Tides that occur semimonthly as the result of the moon being over the equator. At these times the tendency of the moon to cause an inequality in mixed tides is minimized.

Equilibrium - State of balance or equality of opposing forces.

Erosion - Wearing away of land by action of natural forces.

Fetch - Area where waves are generated by wind which has steady direction and speed. Sometimes called FETCH LENGTH.

Fetch Length - Horizontal direction (in the wind direction) over which a wind generates waves. In sheltered waters, often the maximum distance that wind can blow across water.

Filter Cloth - Synthetic textile with openings for water to escape, but which prevents passage of soil particles.

Flood Tide - Part of the tidal cycle between low water and the next high. The rising tide.

Gabion - A wickerwork or wire mesh basket or cage filled with stone or other materials placed against a shoreline either as a mattress or bulkhead to prevent erosion.

Geocomposite Mattress - Fibrous matting consisting of a combination of geotextile and geogrid; or geogrid and geomembrane; or geotextile, geogrid, and geomembrane; or any one of these three materials with another material (e.g., deformed plastic sheets, steel cables, or steel anchors) which is placed on the shoreline for the purpose of preventing erosion. They may be composed of biodegradable wood, straw, coconut, or cellulose fibers (HoldGro, Geojute, Ero-Mat, Excelsior Blanket, etc.) or nonbiodegradable vinyl or nylon (Enkamat, Miramat, Tensarmat, etc.)

Glacial Till - Unstratified glacial drift consisting of unsorted clay, sand, gravel, and boulders intermingled.

Gravel - Small, rounded granules of rock with individual diameters ranging from 3.0 to 0.18 inches. Gravels are intermediate between SAND and COBBLES.

Groin - Shore protection structure built perpendicular to shore to trap sediment and retard shore erosion.

Groin Field - Series of groins acting together to protect a section of beach. Also called a groin system.

Grout - Mixture of portland cement, fine aggregates (usually sand), and water. Usually used to seal openings or fill bags or other containers.

H-Pile - Straight length of structural steel with an H-shaped cross section designed for driving into the earth.

High Tide - Maximum elevation reached by each rising tide. See also TIDE.

High Water - See HIGH TIDE.

Line - Intersection of the level of MEAN HIGH WATER with the shore. Shorelines on navigation charts are approximations of the high water line.

Longitudinal Dike - Riprap or broken concrete placed parallel to the toe of a shoreline (at the natural angle of repose of the stone) to prevent erosion of the toe and induce sediment deposition behind the dike.

Hogwire - Short, smooth-wire fencing of the kind normally used to enclose a pig sty.

Impermeable - Not having openings large enough to permit water to freely pass.

International Great Lakes Datum (IGLD) - Common reference datum for the Great Lakes area based on mean water level in the St. Lawrence River at Father Point, Quebec, and established in 1955.

Intertidal Zone - Land area alternately inundated and uncovered by tides. Usually considered to extend from MEAN LOW WATER to MEAN HIGH WATER.

Lee - Sheltered; part or side facing away from wind or waves.

Leeward - Direction toward which wind is blowing or waves are travelling.

Littoral Material - Sediments moved in the LITTORAL ZONE by waves and currents. Also called littoral drift.

Littoral Transport - Movement of LITTORAL MATERIAL by waves and currents.

Littoral Zone - Indefinite zone extending from the shoreline to just beyond the breaker zone.

Longshore - Parallel to and near the shoreline; same as ALONG-SHORE.

Longshore Transport Rate - Rate of transport of littoral material parallel to shore. Usually expressed in cubic yards per year.

Low Tide - Minimum elevation reached by each falling tide.

Low Water Datum (LWD) - The elevation of each of the Great Lakes to which are referenced the depths shown on navigation charts and the authorized depths of navigation projects.

Low Water Line - Intersection of the low tide level with shore.

Marsh - Area of soft, wet, or periodically inundated land, generally treeless, and usually characterized by grasses and other low growth.

Mean Higher High Water (MHHW) - Average height of the daily higher high water over a 19-year period. Only the higher high water of each of the high waters of a tidal day is included in the mean.

Mean High Water (MHW) - Average height of the daily high waters over a 19-year period. For semidiurnal or mixed tides, the two high waters of each tidal day are included in the mean. For diurnal tides, the single daily high water is used to compute the mean.

Mean Lower Low Water (MLLW) - Average height of the daily lower low waters of a 19-year period. Only the lower low water of each pair of low waters of a tidal day is included in the mean. Long used as the datum for Pacific coast navigation charts, it is now gradually being adopted for use across the United States.

Mean Low Water (MLW) - Average height of the low waters over a 19-year period. For semidiurnal and mixed tides, the two low waters of each tidal day are included in the mean. For a diurnal tide, the one low water of each tidal day is used in the mean. Mean Low Water has been used as datum for many navigation charts published by the National Ocean Survey, but it is being phased out in favor of Mean Lower Low Water for all areas of the United States.

Mean Sea Level - Average height of the sea surface over a 19-year period. Not necessarily equal to MEAN TIDE LEVEL.

Mean Tide Level - Plane midway between MEAN HIGH WATER and MEAN LOW WATER. Not necessarily equal to MEAN SEA LEVEL. Also called half-tide level.

Mitigation - Avoiding the impact of a certain action or part of an action; minimizing impacts by limiting the degree of magnitude of an action; rectifying an impact by repairing, rehabilitating, or restoring the affected environment; reducing an impact over time by preserving and maintaining operations during the life of the action; compensating the impact by replacing or providing substitute resources or environments.

Mitigation Banking - Wetland restoration, creation or enhancement

undertaken expressly for the purpose of providing compensation credits for wetland losses from future development activities (for additional information see Page and Wilcher 1989).

Mixed Tide - A tide in which there is a distinct difference in height between successive high and successive low waters. For mixed tides there are generally two high and two low waters each tidal day. Mixed tides may be described as intermediate between semidiurnal and diurnal tides.

Module - A structural component, a number of which are joined to make a whole.

National Geodetic Vertical Datum (NGVD) - Datum of the United States geodetic level net. Mean Sea Level varies slightly from this datum from place to place along the shores of the nation.

Neap Tides - Tides with decreased ranges that occur when the moon is at first or last quarter, and the pull of the sun and moon are in opposition to each other. The neap range is smaller than the mean range for semidiurnal and mixed tides.

Nearshore - In beach terminology, an indefinite zone extending seaward from the shoreline well beyond the breaker zone.

Nourishment - Process of replenishing a beach either naturally by longshore transport, or artificially by delivery of materials dredged or excavated elsewhere.

Offshore - (1) (Noun) In beach terminology, comparatively flat zone of variable width extending from the breaker zone to the seaward edge of the Continental Shelf. (2) (Adjective) Direction seaward from the shore.

Overtopping - Passing of water over a structure from wave runup or surge action.

Peat - Residual product produced by partial decomposition of organic matter in marshes and bogs.

Peat Pot (vegetation) - Pot formed from compressed peat and filled either with soil or peat moss in which a plant or plants, grown from seed, are transplanted without being removed from the pot.

Perched Beach - Beach or fillet of sand retained above the otherwise normal profile level by a submerged dike or sill.

Perigean Tides - Increased tidal ranges that occur each month when the moon is closest to the earth (perigee).

Permeable - Having openings large enough to permit free passage of appreciable quantities of sand or water.

Pile - Long, heavy section of timber, concrete or metal driven or jetted into the earth or seabed as support or protection.

Pile, Sheet - Pile with a generally slender, flat cross section driven into the ground or seabed and meshed or interlocked with like members to form a diaphragm, wall, or bulkhead.

Piping - Fluidizing of backfill or an embankment to the extent that large quantities of material are pumped by wave action through holes under or through a bulkhead or revetment.

Plasticity - As applied mainly to clay, the relative ease with which the material yields or deforms under pressure.

Plug - Core containing both plants and underlying soil, usually cut with a cylindrical coring device and transplanted to a hole cut by the same device.

Polyvinyl Chloride (PVC) - Plastic material (usually black) that forms a resilient coating suitable for protecting metal from corrosion .

Profile, Beach - Intersection of the ground surface with a vertical plane that may extend from the top of the dune line to the seaward limit of sand movement.

PVC - (see POLYVINYL CHLORIDE).

Ravelling - Progressive deterioration of a revetment under wave action.

Refraction (of water waves) - (1) Process by which direction of a wave moving in shallow water at an angle to the contours is changed. Part of the wave advancing in shallower water moves more slowly than the part still advancing in deeper water, causing the wave crest to bend toward alignment with the underwater contours. (2) Bending of wave crests by currents.

Retard - Structure placed parallel to a shoreline to prevent erosive waves from attacking the bank.

Revetment - Facing of stone, concrete, etc., to protect a scarp, embankment, or shore structure against erosion by waves or currents.

Rhizome - Underground stem or root stock. New shoots are usually produced from the tip of the rhizome.

Riprap - Layer, facing, or protective mound of stones randomly placed to prevent erosion, scour, or sloughing of a structure or embankment; also, the stone so used.

Rubble - (1) Loose, angular, waterworn stones along a beach. (2) Rough, irregular fragments of broken rock or concrete.

Rubble-mound structure - A mound of random-shaped and random-placed stones protected with a cover layer of selected stones or specially shaped concrete armor units. (Armor units in a primary cover layer may be placed in an orderly manner or dumped at random).

Runup - The rush of water up a structure or beach on breaking of a wave. Amount of runup is the vertical height above still-water level that the rush of water reaches.

Sand - Generally, coarse-grained soils having particle diameters between 0.18 and approximately 0.003 inches. Sands are intermediate between SILT AND GRAVELS.

Sandbag - Cloth bag filled with sand or grout and used as a module in a shore protection device.

Sand Fillet - Accretion trapped by a groin or other protrusion in the littoral zone.

Scour - Removal of underwater material by waves or currents, especially at the base or toe of a shore structure.

Screw Anchor - Type of metal anchor screwed into the bottom for holding power.

Seawall - Structure separating land and water areas primarily to prevent erosion and other damage by wave action. See also BULK-HEAD.

Self-Forming Revetment - See TRENCH-FILL REVETMENT, WINDROW REVETMENT.

Semidiurnal Tide - Tide with two high and two low waters in a tidal day, each high and each low approximately equal in stage.

Setup, Wind - Vertical rise in the still-water level on a body of water caused by piling up of water on the shore due to wind action. Synonymous with wind tide and STORM SURGE. STORM SURGE usually pertains to the ocean and large bodies of water. Wind setup usually pertains to reservoirs and smaller bodies of water.

Shallow Water - Commonly, water of such a depth that surface waves are noticeably affected by bottom topography. It is customary to consider water of depths less than one-twentieth the surface wavelength as shallow water.

Sheet Pile - see PILE, SHEET.

Shoal - (noun) Rise of the sea bottom from an accumulation of sand or other sediments. (verb) - (1) to become shallow gradually. (2) To cause to become shallow. (3) to proceed from a greater to a lesser depth of water.

Shoot - Collective term applied to the STEM and leaves or any growing branch or twig.

Shore - Narrow strip of land in immediate contact with the sea, including the zone between high and low water lines. A shore of unconsolidated material is usually called a beach.

Shoreline - Intersection of a specified plane of water with the shore or beach (e.g., the high water shoreline would be the intersection of the plane of mean high water with the shore or beach). The line delineating the shoreline on National Ocean Survey nautical charts and surveys approximates the mean high water line.

Sill - Low offshore barrier structure whose crest is usually submerged, designed to retain sand on its landward side.

Silt - Generally refers to fine-grained soils having particle diameters between 0.003 and 0.00015 inches. Intermediate between CLAY and SAND.

Slope - Degree of inclination to the horizontal. Usually expressed as a ratio, such as 1:25 or 1 on 25, indicating 1 unit vertical rise in 25 units of horizontal distance; or in degrees from horizontal.

Sloughing - Process where a weakened mass of soil fails and moves downslope.

Sprig - Single plant with its relatively bare roots, as pulled apart from a clump and used for transplanting.

Spring Tides - Increased tidal ranges that occur semimonthly when the moon is new or full and the pull of the sun and moon are nearly in phase. The spring range is larger than the mean range for semidiurnal or mixed tides.

Stem - Main axis of a plant, leaf-bearing and flower-bearing, as distinguished from the root-bearing axis.

Still-Water Level (SWL) - Elevation that the surface of the water would assume if all wave action were absent.

Storm Surge - Rise above normal water level on the open coast due to action of wind on the water surface. Storm surge resulting from a hurricane also includes the rise in level due to atmospheric pressure reduction as well as that due to wind stress. See SETUP, WIND.

Suspended Load - Material moving in suspension in a turbulent field .

Swell - Wind-generated waves travelling out of their generating area. Swell characteristically exhibits a more regular and

longer period and has flatter crests than waves within their fetch.

Tidal Period - Interval between two consecutive like phases of the tide.

Tidal Range - Difference in height between consecutive high and low (or higher high and lower low) waters. The mean range is the difference in height between mean high water and mean low water. The diurnal range is the difference in height between mean higher high water and mean lower low water. For diurnal tides, the mean and diurnal range are identical. For semidiurnal and mixed tides, the spring range is the difference in height between the high and low waters during the time of spring tides.

Tide - Periodic rising and falling of water resulting from gravitational attraction of the moon, sun and other astronomical bodies acting upon the rotating earth. Although the accompanying horizontal movement of the water resulting from the same cause is also sometimes called tide, it is preferable to designate the latter as tidal current, reserving the name TIDE for vertical movement.

Tide, Ebb - See EBB TIDE.

Tide Station - Place at which tide observations are being taken. A primary tide station is a location where continuous observations are taken over a number of years to obtain basic tidal data for the locality. A secondary tide station is operated over a short period of time to obtain data for a specific purpose.

Tieback - Structure placed between revetment and bank to prevent flanking (also called return walls).

Tiller - A plant shoot which springs from the root or bottom of the original plant stalk.

Topography - Configuration of a surface, including relief, position of streams, roads, buildings, etc.

Transplant - SHOOT or CULM removed from one location and replanted in another.

Trench-Fill (Self-Forming) Revetment - Stone or broken concrete placed in a trench dug behind and parallel to an eroding shoreline. When the erosive action of the waves reaches the trench, the material placed in the trench armors the bank and thus retards further erosion.

Trough of Wave - Lowest part of a waveform between successive crests. Also, that part of a wave below still-water level.

Tides - Tides that occur semimonthly when the declination

of the moon is maximized. During these times, the diurnal range tends to be greatest.

Updrift - Direction opposite the predominant movement of littoral materials in longshore transport.

Wake (boat) - Waves generated by the motion of a vessel through water.

Wale - Horizontal beam on a bulkhead used to transfer horizontal loads against the structure laterally along it and hold it in a straight alinement.

Waterline - Juncture of land and sea. This line migrates, changing with the tide or other fluctuation in water level. Where waves are present on the beach, this line is also known as the limit of backrush. (Approximately, the intersection of land with the still-water level).

Wave - Ridge, deformation, or undulation of the surface of a liquid.

Wave Climate - Normal seasonal wave regimen along a shoreline.

Wave Crest - Highest part of a wave or that part above the still-water level.

Wave Diffraction - See DIFFRACTION.

Wave Direction - Direction from which a wave approaches.

Wave Height - Vertical distance between a crest and the preceding trough.

Wavelength - Horizontal distance between similar points on two successive waves measured perpendicular to the crest.

Wave Period - Time in which a wave crest traverses a distance equal to one wavelength. Time for two successive wave crests to pass a fixed point.

Wave Refraction - See REFRACTION (of water waves).

Wave Steepness - Ratio of wave height to wavelength.

Wave Train - Series of waves from the same direction.

Wave Trough - Lowest part of a wave form between successive crests. Also, that part of a wave below still-water level.

Weep Hole - Hole through a solid revetment, bulkhead, or seawall for relieving pore pressure.

Wetland - Periodically inundated communities characterized by

vegetation which survives in wet soils, ranging from coastal intertidal marshes to freshwater swamps and bottomland hardwoods. These areas usually have quite distinctive vegetation communities.

Wind Setup - See SETUP, WIND.

Windward - Direction from which wind is blowing.

Wind Waves - (1) Waves being formed and built up by wind. (2) Loosely, any waves generated by wind.

Windrow (Self-Forming) Revetment - A row of stone or broken concrete (called a windrow) placed on top bank landward of an eroding shoreline. As erosion continues the windrow is eventually undercut, launching the stone downslope, thus armoring the bank face.