

TA7
W34
no. GL-93-29
c.3

Technical Report GL-93-29
November 1993

**U.S. Army Corps
of Engineers**
Waterways Experiment
Station

Geophysical Investigation at U.S. Army Materials Technology Laboratory, Massachusetts

*by José L. Llopis, Janet E. Simms
Geotechnical Laboratory*

The logo for the Waterways Experiment Station (WES) is displayed in a stylized, italicized font. The letters 'W', 'E', and 'S' are composed of multiple horizontal lines, giving the logo a sense of motion or a layered appearance.

Approved For Public Release; Distribution Is Unlimited

Prepared for U.S. Army Environmental Center

29526480

TA7
W34
no. GL-93-29
c.3

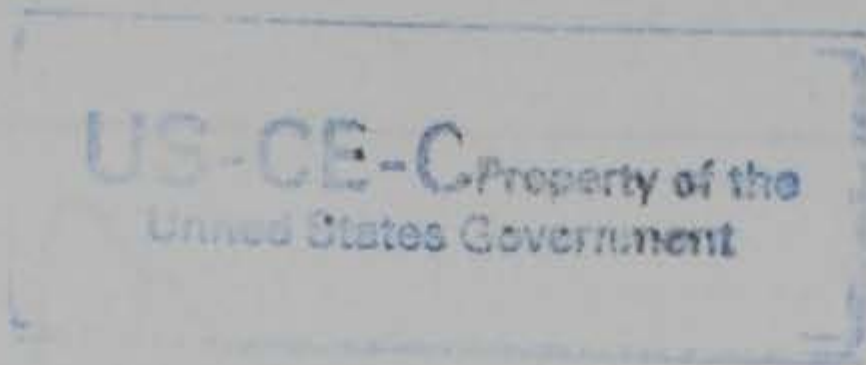

Technical Report GL-93-29
November 1993

Geophysical Investigation at U.S. Army Materials Technology Laboratory, Massachusetts

by José L. Llopis, Janet E. Simms
Geotechnical Laboratory

U.S. Army Corps of Engineers
Waterways Experiment Station
3909 Halls Ferry Road
Vicksburg, MS 39180-6199

Final report

Approved for public release; distribution is unlimited

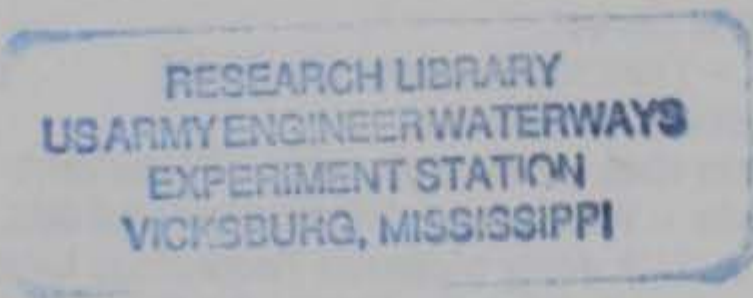

Prepared for U.S. Army Environmental Center
Aberdeen Proving Ground, MD 21010-5401



**US Army Corps
of Engineers**
Waterways Experiment
Station

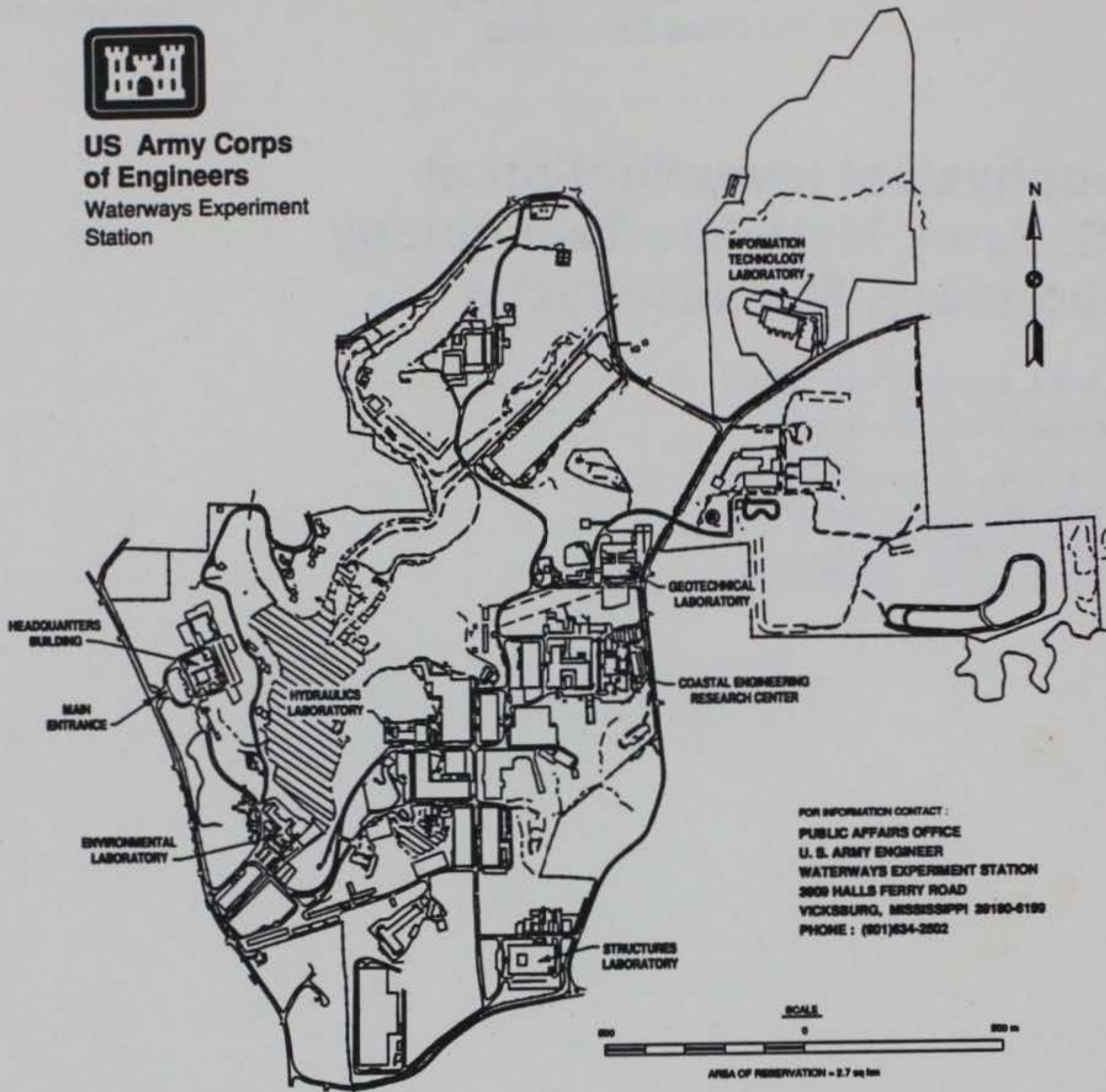

Waterways Experiment Station Cataloging-In-Publication Data

Llopis, José L.

Geophysical investigation at U.S. Army Materials Technology Laboratory, Massachusetts / by José Llopis, Janet E. Simms ; prepared for U.S. Army Environmental Center.

75 p. : ill. ; 28 cm. -- (Technical report ; GL-93-29)

Includes bibliographical references.

1. Hazardous waste sites -- Massachusetts -- Watertown. 2. Soil surveys -- Massachusetts -- Watertown -- Geophysical methods. 3. Ground penetrating radar. 4. U.S. Army Materials Technology Laboratory.

I. Simms, Janet E. II. U.S. Army Environmental Center. III. U.S. Army Engineer Waterways Experiment Station. IV. Title. V. Series: Technical report (U.S. Army Engineer Waterways Experiment Station) ; GL-93-29.

TA7 W34 no.GL-93-29

Contents

Preface	iv
Conversion Factor, Non-SI to SI Units of Measurement	v
1—Introduction	1
Background	1
Objectives	1
2—Geophysical Test Principles and Field Procedures	3
Geophysical Test Principles	3
Electromagnetic surveys	3
Magnetic surveys	4
Ground penetrating radar	5
Field Methods	6
3—Geophysical Test Results	7
Presentation of Test Results	7
Test Results	7
Site 1 (parking lot south of bldg. 36)	7
Site 2 (between North Beacon Street and fuel storage area)	10
Site 3 (parking lot south of bldg. 37)	11
Site 4 (parking lot west of bldg. 39)	13
Site 5 (parking lot south of bldg. 243)	15
4—Data Interpretation	18
5—Conclusions and Recommendations	24
References	25
Figures 1 - 42	
SF 298	

Preface

A geophysical investigation was conducted at the U.S. Army Materials Technology Laboratory, Watertown, Massachusetts, by personnel of the Geotechnical Laboratory (GL), U.S. Army Engineer Waterways Experiment Station (WES), between 1 and 4 October 1992. The investigation was conducted for the U.S. Army Environmental Center (AEC), Aberdeen Proving Ground, Maryland. The AEC Technical Monitors were Ms. Phyllis Breland and Mr. Mark Mahoney. Mr. William Nelson (AEC) was project geologist.

This report was prepared by Mr. José L. Llopis and Dr. Janet E. Simms, Earthquake Engineering and Geosciences Division (EEGD). The work was performed under the direct supervision of Mr. Joseph R. Curro, Jr., Chief, Engineering Geophysics Branch. The work was performed under the general supervision of Drs. A. G. Franklin, Chief, EEGD, and William F. Marcuson III, Director, GL. Field work and data analysis were performed by Mr. José L. Llopis and Dr. Janet E. Simms. Mr. William Megehee, EEGD, assisted in drafting and preparing the report figures.

At the time of publication of this report, Director of WES was Dr. Robert W. Whalin. Commander was COL Bruce K. Howard, EN.

Conversion Factors, Non-SI to SI Units of Measurement

Non-SI units of measurement used in this report can be converted to SI units as follows:

Multiply	By	To Obtain
acres	4,046.873	square meters
feet	0.3048	meters
gamma	1.0	nanotesla
miles (U.S. statute)	1.609347	kilometers
miles per hour	1.609347	kilometers per hour
millimhos per foot	3.28	millimhos per meter
millimhos per foot	3.28	milliSiemens per meter

1 Introduction

Background

The U.S. Army Materials Technology Laboratory (MTL) is located on 36.5 acres of land on the north bank of the Charles River in Watertown, MA, approximately 5 miles west of Boston (Figure 1). The facility was established in 1816 by President James Madison and was originally used for the storage, cleaning, repair, and issue of small arms and ordnance supplies. During the 1800's the mission was expanded to include ammunition and pyrotechnics production; materials testing and experimentation with paint, lubricants, and cartridges; and manufacture of breech-loading steel guns and cartridges for field and siege guns. Arms manufacturing continued at the facility until operational phasedown was initiated in 1967. In 1960, the Army's first materials research reactor was completed at MTL, which was used actively in molecular and atomic structure research activities until 1970, when it was deactivated.

In December of 1989, the Secretary of Defense's ad hoc Commission on Base Realignment and Closure issued its final report that included a recommendation, subsequently approved by Congress, for the closure of 81 Department of Defense installations, including MTL. The MTL closure program is being supervised by the U.S. Army Environmental Center (AEC).

Both the research reactor and the facilities that handled depleted uranium (DU) were associated with the storage, testing and handling of radioactive materials. The purpose of the geophysical investigation was to characterize those sites not previously studied, to determine if anomalies exist, and to aid in the decision to conduct remedial actions.

Objectives

At the request of AEC, personnel of the U.S. Army Engineer Waterways Experiment Station (WES) conducted a geophysical investigation at five locations at MTL during the period 1 and 4 October 1992 (Figure 2). Geophysical surveys were conducted at Sites 1 and 2 to delineate anomalies indicative of buried waste and waste containers. The waste supposedly consists of buried drums of DU and/or burlap sacks containing sand and DU chips. Site 1 was a parking lot south of Bldg. 36 where former Bldg. 45 was located and

Site 2 was an area between Bldg. 295 (fuel storage tanks) and the south boundary fence. Site 3 was located south of Bldg. 37 and was investigated to determine the presence of a suspected underground storage tank (UST). Sites 4 and 5 were investigated to delineate anomalies indicative of unmapped underground drain or sewer lines with the potential of carrying wastes off site. Site 4 was a parking lot located west of Bldg. 39 whereas, Site 5, also a parking lot, was located northwest of Bldg. 39 and south of Bldg. 243 as shown in Figure 2. Electromagnetic (EM), magnetic, and ground penetrating radar (GPR) surveys were conducted at the sites to accomplish these objectives.

2 Geophysical Test Principles and Field Procedures

Geophysical Test Principles

Electromagnetic surveys

The EM technique is used to measure differences in terrain conductivity. Like electrical resistivity, conductivity is affected by differences in soil porosity, water content, chemical nature of the ground water and soil, and the physical nature of the soil. In fact, for a homogeneous earth, the true conductivity is the reciprocal of the true resistivity. Some advantages of using the EM over the electrical resistivity technique are (a) less sensitivity to localized resistivity inhomogeneities, (b) no direct contact with the ground required, thus no current injection problems, (c) smaller crew size required, and (d) rapid measurements (McNeil, 1980). The DU chips should be detectable if buried in the near-surface in metal containers. However, because DU is not a good electrical conductor and is only very weakly magnetic, it may not be detected if buried in burlap sacks unless it is in sufficient quantity to create a conductivity contrast with that of the surrounding material.

The EM equipment used in this survey consists of a transmitter and receiver coil set a fixed distance apart. The transmitter coil is energized with an alternating current at an audio frequency (Khz range) to produce a time-varying magnetic field which in turn induces small eddy currents in the ground. These currents then generate secondary magnetic fields which are sensed together with the primary field by the receiver coil. The units of conductivity are millimhos per meter (mmho/m) or, in the SI system milliSiemens per meter (mS/m). The EM data are then presented in profile plots or as isoconductivity contours if data are obtained in a grid form. A more thorough discussion on EM theory and field procedures is given by Butler (1986), Telford et al. (1973) and Nabighian (1988).

There are two components of the induced magnetic field measured by the EM equipment. The first is the quadrature phase component, which gives the ground conductivity measurement. The second is the in-phase component, which is used primarily for calibration purposes. However, the in-phase component is significantly more sensitive to large metallic objects and hence very useful when looking for buried metal containers (Geonics Limited 1984).

When measuring the in-phase component, the true zero level is not known since the reference level is arbitrarily set by the operator. Therefore, measurements collected in this mode are relative to a reference level and have arbitrary units of parts per thousand (ppt).

A Geonics model EM-31 ground conductivity meter was used to survey the sites. The EM-31 has an intercoil spacing of 12 ft and an effective depth of exploration of about 20 ft (Geonics Limited 1984). The EM-31 meter reading is a weighted average of the earth's conductivity as a function of depth. A thorough investigation to a depth of 12 ft is usually possible, but below that depth the effect of conductive anomalies becomes more difficult to distinguish. The EM-31, when carried at a usual height of approximately 3 ft, is most sensitive to features at a depth of about 1 ft. Half of the instrument's readings result from features shallower than about 9 ft, and the remaining half from below that depth (Bevan 1983). Figure 3 more clearly illustrates the effect of depth on instrument sensitivity with the dashed line depicting the sensitivity of the instrument to objects between it and the ground surface. The instrument can be operated in both a horizontal and vertical dipole orientation (Figure 4) with correspondingly different effective depths of exploration. The instrument is normally operated with the dipoles vertically oriented (coils oriented horizontally and co-planar) which gives the maximum depth of penetration. The instrument can be operated in a continuous or a discrete mode.

Magnetic surveys

The magnetic method of surveying is based on the ability to measure local disturbances of the earth's magnetic field. Magnetic anomalies are caused by two different types of magnetism: induced and remanent magnetization (Parasnis 1966 and Breiner 1973). Remanent magnetization is a permanent magnetic moment per unit volume whereas induced magnetization is temporary magnetization that disappears if the material is removed from a magnetic field. Generally, the induced magnetization is parallel with and proportional to the inducing field (Barrows and Rocchio 1990). The remanent magnetism of a material depends on the thermal and magnetic history of the body and is independent of the field in which it is measured (Breiner 1973).

An EDA OMNI IV proton-precession magnetometer was used to measure the total field intensity of the local magnetic field. The magnetic unit of measurement is the nanotesla (nT) or gamma. One nanotesla is equivalent to one gamma. The local magnetic field is the vector sum of the field of the local magnetized materials (local disturbance) and the ambient (undisturbed) magnetic field. Figure 5 shows the ambient earth's field as 50,000 nT with a local disturbance of 10 nT. Figure 5 shows that the quantity measured with the magnetometer is the resultant total field with a value of 50,006 nT.

The magnetometer was also used with dual sensors thereby allowing the gradient of the total magnetic field to be measured. The gradient is taken by measuring the total field at the two sensors which are fixed a small distance apart. The difference in values between the two sensors divided by their sepa-

ration approximates the gradient measured at the midpoint of the sensor spacing. Two advantages of using the magnetic gradient are that 1. the regional magnetic gradient is filtered out thus local anomalies are better defined and 2. since the two readings are taken simultaneously magnetic storm effects and diurnal magnetic variations are essentially removed (Breiner 1973). The magnetometer used in this survey has an absolute accuracy of approximately ± 1 nT. For reference, the earth's magnetic field varies from approximately 60,000 nT at the poles to 30,000 nT at the equator (the nominal field strength at MTL is 51,000 nT).

A magnetic anomaly represents a local disturbance in the earth's magnetic field which arises from a localized change in magnetization, or magnetization contrast. The observed anomaly expresses the net effect of the induced and remanent magnetization and the earth's ambient magnetic field. Depth of detection of a localized subsurface feature depends on its mass, magnetization, shape and orientation, and state of deterioration.

Ground penetrating radar

Ground penetrating radar (GPR) is a geophysical subsurface exploration method using high frequency EM waves. The GPR system consists of a transmitting and a receiving antenna. The transmitting antenna transmits an EM signal into the ground and is reflected by materials having contrasting electrical properties back to the receiving antenna. These signals are then amplified, processed and recorded to provide a continuous profile of the subsurface.

The transmitted EM waves respond to changes in soil and rock conditions having sufficiently different electrical properties such as those caused by clay content, soil moisture or ground water, water salinity, cementation, man-made objects, voids, etc. The depth of exploration is determined by the electrical properties of the soil or rock as well as by the power of the transmitting antenna. The primary disadvantage to GPR is its extremely site specific applicability; the presence of high-clay content soils in the shallow subsurface will generally defeat the application of GPR (Olhoeft 1984). High water contents in the shallow subsurface and shallow water tables can also limit the applicability of GPR at some sites. A general rule is that GPR should not be applied to projects in which the mapping objective is greater than 50 ft in depth. For shallow mapping applications at sites with low clay content soils, GPR will generally have the best vertical and horizontal resolution of any geophysical method (Butler and Llopis 1990).

A Geophysical Survey Systems, Inc. SIR System-8 radar with a 300 Mhz antenna as shown in Figure 6 was used to conduct the GPR surveys. A graphic recorder was used with the SIR System-8. The graphic recorder accepts the analog signal from the receiver and produces a continuous, permanent chart on electro-sensitive paper. By recording a vertical intensity modulated scan for every few inches of antenna travel, a continuous profile is developed showing reflections from subsurface strata and anomalies within the strata.

Soils at MTL are agriculturally classified as Merrimac gravelly sandy loam, although they have been significantly altered as a result of numerous construction and fill activities (Roy F. Weston, Inc. 1992). Much of the site is overlain by sand and gravel fill material, which is underlain by less coarse glacial till deposits. The groundwater table ranges in depth from approximately 4 ft in the southeastern corner of the site to 24 ft in the northwestern corner.

Field Methods

Detailed surveys were conducted by establishing rectangular-shaped grids at the sites to encompass the area of interest. The grid stations at the sites were marked at constant intervals with chalk on paved areas and by implanting polyvinyl chloride (PVC) stakes into the ground in grassy areas. PVC stakes were used to prevent any possible interference with the geophysical tests conducted at the sites. Magnetic and EM-31 readings were taken at 10 ft intervals over the gridded areas. Continuous GPR survey profile lines were taken along the long axis of the sites and in some cases additional GPR survey profile lines were collected transverse to the long axis of the site. The distance between GPR profile lines ranged between 5 and 20 ft with the distance between profile lines being dependent on the shape and size of the target of interest.

The EM-31 data were taken in both the quadrature phase (conductivity) and in-phase mode at each measurement station. Measurements were recorded on a digital data logger and transferred to a portable field computer at the conclusion of the survey.

Total magnetic field and magnetic gradient readings were taken at each survey point. Data were collected and stored in the internal memory of the magnetometer and transferred to a portable field computer at the conclusion of the survey.

The radar antenna was hand-towed along each survey line at a slow walking rate (approximately 1 to 2 miles per hour) while the control unit and graphic recorder were operated from a motor vehicle. Station positions were established on the radar records by electronically impressing dashed, vertical reference lines on the graphic records as the antenna passed each marked location.

3 Geophysical Test Results

Presentation of Test Results

The results of the EM-31 and magnetic surveys for Sites 1,3,4 and 5 are presented as contour maps of the measured values. The color contour maps show a two-dimensional representation of the data with hot colors (reds) indicating areas with relatively high values and cold colors (blues) showing areas with relatively low values. No contour plots of EM-31 or magnetic survey results were prepared for Site 2 because the site was too narrow to make a meaningful contour plot. Instead, profile plots showing the survey values were prepared. The plots of the GPR survey results are presented showing areas of discrete hits (depicted with an "X" for Sites 1,3,4 and 5 and with an "*" for Site 2) and disturbed areas (depicted by shaded areas). A discrete hit was identified by a hyperbolic shape on the radar record due to an isolated buried object, whereas a disturbed area was characterized by a section of discontinuous reflectors and is generally associated with fill zones.

Superimposed on the contour and GPR plots are the locations of cultural features (metal signs, lamp posts, steel grates, etc.) which may have an affect or interfere with the survey results. By superimposing the cultural features on the contour plots anomalous features caused by these features can be accounted for and not misinterpreted as being caused by an unknown buried feature. Maps of underground utilities (steam pipes, sewer lines, water lines, etc.) were obtained from the Facilities Engineering Branch, MTL in order to determine any correlation between interpreted anomalies and mapped utilities.

Test Results

Site 1 (parking lot south of bldg. 36)

Figure 7 shows the location of Site 1 and the extent of the surveyed area. Figure 7 also shows the location of the known buried utilities and utility tunnel. Figure 8 shows the layout of the survey grid along with the location of cultural features. Total field magnetic, magnetic gradient, EM-31 conductivity and in-phase, and GPR survey results are presented in Figures 9 through 13, respectively. EM and magnetic readings were taken on a 10-ft grid interval across the site. The survey stations are denoted on the maps by the tick

marks along each survey line. GPR survey lines were run in a east-west direction with a 5-ft survey line separation.

The results of the magnetic total field, magnetic gradient, EM-31 conductivity and in-phase surveys are given in Figures 9-12, with descriptions and locations of significant anomalies presented in Tables 1-4, respectively.

The GPR anomaly results are presented in Figure 13. As previously mentioned, individual GPR anomalies are represented with an "X" whereas, more widespread anomalies are represented by the shaded areas. Numerous individual anomalies as well as disturbed areas were interpreted. The linear anomaly extending from (100W, 00N) to (150W, 130N) as seen on the other anomaly maps is also detected by the GPR, as well as a disturbed area between (140-190W, 65-85N).

Table 1
Description and Location of Significant Magnetic Total Field Anomalies, Site 1

Anomaly Reference Number	Anomaly Description and Location
1	Approximately 10-ft wide positive linear anomaly extending from (100W,00N) to (145W,130N).
2	Positive linear anomaly extending from (140W,70N) to (190W,70N).
3	Spatially small positive linear anomaly extending between (150W,110N) and (180W,110N).
4	Circular negative anomaly located at (00W,90N).
5	Small negative anomaly located at (10W,130N).
6	Small positive anomaly centered on (70W,115N).
7	Positive 10-15 ft wide anomaly located between (160W,25N) and (210W,15N).

Table 2
Description and Location of Significant Magnetic Gradient
Anomalies, Site 1

Anomaly Reference Number	Anomaly Description and Location
1	Circular anomaly centered on (05W,70N).
2	Circular anomaly centered on (10W,130N).
3	Linear anomaly between (40W,75N) and (85W,70N).
4	Small circular anomaly centered on (70W,110N).
5	Series of linear trending anomalies extending from (110W,00N) to (150W,130N).
6	Anomalous area bounded approximately by (140W,50N),(140W,120N), (210W,120N), and (210W,50N).
7	Anomalous area centered on (180W,20N).

Table 3
Description and Location of Significant EM-31 Conductivity
Anomalies, Site 1

Anomaly Reference Number	Anomaly Description and Location
1	Approximately 10-ft wide linear low conductivity anomaly extending from (100W,00N) to (150W,130N).
2	High conductivity linear anomaly extending from (30W,130N) to (140W,130N).
3	Spatially large, high conductivity anomaly centered on (165W,100N).
4	Small, high conductivity anomaly located at (185W,130N).
5	Small negative anomaly located at (10W,130N).
6	A high-low conductivity anomaly centered on (195W,75N).

Table 4
Description and Location of Significant EM-31 In-phase Anomalies,
Site 1

Anomaly Reference Number	Anomaly Description and Location
1	Negative circular anomaly centered approximately around (05W,50N).
2	Small negative anomaly centered around (15W,120N).
3	Negative 10-ft wide linear anomaly extending from (115W,00N) to (150W,130N).
4	Small positive anomaly centered around (130W,10N).
5	Circular negative anomaly located at (50W,80N).
6	Large positive anomaly centered about (170W,90N).
7	Small positive anomaly centered about (205W,75N).

Site 2 (between North Beacon Street and fuel storage area)

Site 2 is a narrow strip of land located between North Beacon Street and the fuel storage area as shown in Figure 14. Figure 14 also shows the location of cultural features which might have the potential to interfere with the geophysical readings. The width of the site varied between 5 and 15 ft, whereas the length varied between 120 and 310 ft. The western portion of the site sloped steeply to the south (towards North Beacon Street) causing Lines 00N and 05N to be shortened. Magnetic total field, EM-31 conductivity and in-phase, and GPR surveys were conducted at this site. Magnetic and EM-31 readings were taken at 10-ft intervals along each survey line. GPR surveys were run along the entire length of each survey line.

Figures 15 through 17 present the magnetic, conductivity, and in-phase data, respectively, for Site 2. The figures have been annotated indicating the location of buried lines, manhole covers, monitoring wells, and other features which might affect these readings. The graphed data show many anomalies as indicated by the peaks and valleys. The majority of these anomalies can be attributed to interference from cultural features. Figure 18 was prepared to show the location of the anomalies as interpreted from the different tests and to indicate their relative position to cultural features. Also presented in Figure 18 are the interpreted anomalies from the GPR survey. Figure 18 shows that indeed, most of the anomalies occur in the vicinity of, and are being affected by underground lines, manhole covers, and monitoring wells. However, there are basically two anomalous zones that cannot be attributed to known cultural features. One zone consists of anomalous conductivity readings (Lines 00N, 05N, and 10N) located approximately 120 ft west of the survey line starting point. The other anomalous area is located on line 05N approximately 140-150 ft west of the survey line starting point where a small

magnetic and a significant in-phase anomaly were interpreted. The disturbed anomalous zones determined from the GPR surveys appear to correspond with the location of cultural features.

Site 3 (parking lot south of bldg. 37)

Figure 19 shows the location of Site 3 and the boundaries of the geophysical survey along with the locations of known buried utilities. Figure 20 shows the layout of the geophysical survey grid and the location of cultural features. The survey encompassed an area measuring 180 ft by 60 ft. Total field magnetic, magnetic gradient, EM-31 conductivity and in-phase, and GPR surveys were conducted at this site and are presented in Figures 21 through 25, respectively. EM-31 and magnetic readings were taken on a 10-ft grid interval. GPR survey lines were run in an east-west fashion with a 5-ft survey line separation. As previously mentioned the purpose of this survey was to determine the presence of a UST near the northern portion of the parking lot.

The results of the magnetic total field, magnetic gradient, EM-31 conductivity and in-phase surveys are presented in Figures 21-24, respectively. The significant anomalies interpreted from these surveys are presented in Tables 5-8, respectively.

The GPR anomaly results for Site 3 are presented in Figure 25. Individual GPR anomalies are represented with an "X" whereas, more widespread anomalies are represented by the shaded areas. Numerous individual anomalies as well as disturbed areas were interpreted. A large disturbed area is noted in the northern portion of the parking lot. Also, there is a large concentration of individual GPR anomalies in the western portion of the parking lot.

Table 5 Description and Location of Significant Magnetic Total Field Anomalies, Site 3	
Anomaly Reference Number	Anomaly Description and Location
1	A plus-minus anomaly centered on (75W,00N).
2	Positive circular anomaly centered on (65W,35N).
3	Large elongated negative anomaly extending between approximately (20W,60N) and (95W,60N).
4	Circular positive anomaly located at (150W,15N).
5	Positive anomaly located at (160W,60N).

Table 6
Description and Location of Significant Magnetic Gradient
Anomalies, Site 3

Anomaly Reference Number	Anomaly Description and Location
1	Circular positive anomaly centered on (00W,00N).
2	Negative anomaly centered on (35W,60N).
3	Positive anomaly centered on (80W,00N).
4	Small circular anomaly centered on (65W,40N).
5	Negative anomaly located at (85W,60N).
6	Positive anomaly centered at (150W,15N).
7	Positive anomaly centered on (160W,60N).

Table 7
Description and Location of Significant EM-31 Conductivity
Anomalies, Site 3

Anomaly Reference Number	Anomaly Description and Location
1	Approximately 5 to 10-ft wide linear high conductivity anomaly extending from (20W,60N) to (170W,60N).
2	Low conductivity anomaly centered at (70W,00N).
3	Low conductivity anomaly centered on (150W,20N).

Table 8
Description and Location of Significant EM-31 In-phase Anomalies,
Site 3

Anomaly Reference Number	Anomaly Description and Location
1	Positive circular anomaly centered approximately around (25W,25N).
2	Small negative anomaly centered around (00W,60N).
3	Positive circular anomaly centered about (35W,60N).
4	Small positive anomaly centered around (50W,20N).
5	Circular negative anomaly located at (65W,00N).
6	Negative anomaly centered about (60W,60N).
7	Positive anomaly centered about (95W,15N).
8	Positive anomaly centered about (125W,00N).
9	Large positive anomaly centered about (140W,20N).
10	Elongate positive anomaly extending between (140W,60N) and (180W,60N).

Site 4 (parking lot west of bldg. 39)

As previously mentioned a geophysical investigation was carried out at Site 4 to determine the location of unknown drain lines. The location of the boundaries of the geophysical survey and the known buried utility lines for Site 4 are shown in Figure 26. The layout of the geophysical grid and location of cultural features are shown in Figure 27. The gridded area covered an area 150 ft by 120 ft. Magnetic total field, EM-31 conductivity and in-phase measurements were taken on a 10-ft grid interval. GPR survey lines were run in an east-west and north-south fashion at 10-ft survey line intervals. To facilitate in the detection of pipes or drain lines, GPR survey lines are usually run perpendicular to these linear features. Since the direction of the suspect drain lines was unknown at Site 4, GPR lines were run in an east-west and north-south configuration.

The results of the magnetic total field, EM-31 conductivity and in-phase surveys for Site 4 are presented in Figures 28-30, respectively. The significant anomalies interpreted from these surveys are shown in Tables 9-11, respectively.

The GPR anomaly results for Site 4 are presented in Figure 31. There are numerous GPR anomalies scattered across the surveyed area. It is noted that there is a high concentration of GPR disturbed areas in the northwest portion of the site coinciding with interpreted anomalous areas from EM-31 and magnetic surveys.

Table 9
Description and Location of Significant Magnetic Total Field Anomalies, Site 4

Anomaly Reference Number	Anomaly Description and Location
1	Magnetic low anomaly located approximately between (10W,20N) and (10W,70N).
2	Magnetic low anomaly located approximately between (20W,50N) and (45W,50N).
3	High magnetic anomaly encompassing the northwest portion of the site.
4	Magnetic low anomaly along the southern boundary of site between (00W,00N) (150W,00N).

Table 10
Description and Location of Significant EM-31 Conductivity Anomalies, Site 4

Anomaly Reference Number	Anomaly Description and Location
1	Conductivity low anomaly located approximately between (10W,20N) and (10W,80N).
2	Conductivity low anomaly located approximately between (20W,60N) and (50W,60N).
3	High conductivity anomaly along the southern portion of the survey area.
4	High-low broad (approx. 30 ft wide) conductivity anomaly in northwest portion of the site. Anomaly is centered along a line between (40W,120N) and (150W,50N).

Table 11 Description and Location of Significant EM-31 In-phase Anomalies, Site 4	
Anomaly Reference Number	Anomaly Description and Location
1	Negative anomaly along the eastern perimeter of survey area.
2	Elongated east-west trending negative anomaly between approximately (25W,60N) and (70W,60N).
3	Elongated positive anomaly along the southern perimeter of survey area.
4	Broad, diagonally oriented anomaly in the northwest portion of the survey area. The anomaly runs along a line with approximate end points (30W,120N) and (130W,50N).

Site 5 (parking lot south of bldg. 243)

A geophysical survey using magnetic total field and EM-31 conductivity and in-phase methods was conducted at Site 5 to delineate the location of possible drain pipes. The area covered by the survey and the location of underground utilities is presented in Figure 32. Figure 33 shows the survey grid points and the location of cultural features. Geophysical readings were taken on a 10-ft grid spacing. GPR lines were run east to west with lines spaced 10 ft apart. An additional three lines oriented in a north-south sense were run along lines 20E, 00E, and 20W.

The magnetic total field, EM-31 conductivity and in-phase survey results are presented in Figures 34-36, respectively. A description and location of the significant anomalies are presented in Tables 12-14, respectively.

The results of the GPR survey are presented in Figure 37. Two disturbed areas were interpreted near the eastern portion of the site. Numerous GPR individual anomalies were interpreted across the site.

Table 12
Description and Location of Significant Magnetic Total Field Anomalies, Site 5

Anomaly Reference Number	Anomaly Description and Location
1	Magnetic low anomaly located along eastern portion of the site.
2	Magnetic high anomaly located between approximately (25E,40N) and (15W,40N).
3	Low magnetic anomaly located between approximately (15W,40N) and (50W,40N).
4	Elongated east-west trending magnetic high anomaly extending between (25E,20N) and (30W,20N).
5	Small negative anomaly centered about (00W,00N).
6	Magnetic high anomaly centered on (80W,40N).

Table 13
Description and Location of Significant EM-31 Conductivity Anomalies, Site 5

Anomaly Reference Number	Anomaly Description and Location
1	Conductivity high anomaly centered about (50E,20N).
2	Possible small anomaly centered about (30E,20N).
3	Conductivity high anomaly located along northern portion of the site approximately between (50E,40N) and (40W,40N). This may be two separate anomalies.
4	Small negative anomaly centered about (00W,00N).
5	Conductivity high anomaly centered on (80W,40N).

Table 14
Description and Location of Significant EM-31 In-phase Anomalies,
Site 5

Anomaly Reference Number	Anomaly Description and Location
1	Negative anomaly centered about (30E,20N).
2	Large positive anomaly between (05E,40N) and (50W,40N). Small negative anomaly centered about (55W,40N) is probably associated with this positive anomaly.
3	In-phase positive anomaly centered about (00W,00N).
4	In-phase positive anomaly centered on (80W,40N).

4 Data Interpretation

In determining which of the anomalous areas are to be considered significant, several factors must be considered. Anomaly detection is limited by instrument accuracy and local "noise" or variations in the measurements caused by factors not associated with the anomalies of interest. For the anomaly to be significant, it must be two to three times greater than responses due to these factors. Since the anomaly amplitude, spatial extent, and wavelength are the keys to detection, the size and depth of the feature causing the anomaly are important factors in determining detectability and resolution. The intensity of the anomaly is also a function of the degree of contrast in material properties between the anomaly and the surrounding material. Based upon the methods employed, noise conditions at the site and the assumption that the target objects are relatively shallow (less than 10 ft), the areas indicated as anomalous in Section 3 (Geophysical Test Results) can be considered as significant. In the interpretation of the results, the above criteria were utilized and refer to anomalies caused by localized contrasts in magnetic susceptibility and electrical properties.

The location, an anomaly reference number, type, and an interpretation of the anomalies resulting from the geophysical surveys conducted at Sites 1 through 5 are presented in Tables 15-19, respectively. The tables also indicate whether further action should be taken to determine the cause of the anomaly. The location of the geophysical anomalies described in Tables 15-19 (Sites 1 through 5) are shown in Figures 38 through 42, respectively. The numbered areas refer to the anomaly reference numbers used in the corresponding anomaly interpretation table.

Table 15
Geophysical Anomaly Interpretation, Site 1 (Parking Lot South of Bldg. 36)

General Anomaly Location	Anomaly reference number	Magnetometer		EM-31		GPR	Anomaly Description and Interpretation	Further action required? Yes/No
		T	G	C	I			
(100W,00N) to (150W,130N)	1	X	X	X	X	X	Linear anomaly approximately 10 ft wide. Magnetic gradient shows an indication of an anomaly. Anomaly is due to tunnel beneath the parking lot.	No
(170W,90N)	2	X	X	X	X		Large anomalous area. Indicative of buried ferrous material. Possibly old building foundation or rubble.	Yes
(05W,120N-130N)	3	X	X		X		Anomaly probably caused by a metal grate and metal sign in the area.	No
(70W,110N)	4	X	X				Anomaly caused by unknown ferrous object.	Yes
(60W,80N)	5		X	X	X	X	Weak anomaly. May be caused by small ferrous object.	Yes
(190W,20N)	6	X	X	X	X	X	Anomaly probably due to buried ferrous objects.	Yes
(190W,80N)	7	X	X	X	X	X	Anomaly caused by parked vehicle.	No
(30W,130N) to (140W,130N)	8			X			High conductivity anomaly along northern portion of parking lot. May be caused by sidewalk or buried utility line.	No
(180W,130N)	9	X	X	X	X	X	Anomaly caused by metal manhole cover and/or buried utility line.	No
(00W,50N-80N)	10		X		X		Anomaly probably caused by a buried ferrous object. Steel grate is the probable cause.	No

Note: T = magnetic total field
 G = magnetic gradient
 C = EM-31 conductivity
 I = EM-31 in-phase

Table 16
Geophysical Anomaly Interpretation, Site 2 (Between North Beacon Street and Fuel Storage Area)

General anomaly location	Anomaly reference number	Mag	EM-31		GPR	Anomaly description and interpretation	Further action required? Yes/No
		T	C	I			
00W Lines 00N - 15N	1	X		X		These anomalies are probably associated with a mapped buried storm drain.	No
30W 05N - 15N	2		X		X	These anomalies are probably associated with a mapped buried storm drain.	No
45W Lines 00N - 15N	3	X	X	X		A north-south trending anomaly may be caused by a combination of the monitoring well and mapped buried storm drain and sewer line.	No
90W Lines 00N - 15N	4	X				A north-south trending anomaly probably caused by a mapped storm drain.	No
110W Lines 00N - 15N	5		X	X	X	A north-south trending anomaly probably caused by an unmapped subsurface utility line.	Yes
140W Line 05N	6	X		X		Small anomalous area probably caused by a small shallowly buried ferrous object.	Yes
170W Lines 05N - 15N	7	X	X	X	X	A north-south trending anomaly. Caused by a combination of a buried metal pipe and a metal manhole cover in the vicinity.	No
220W Lines 10N & 15N	8	X		X		A north-south trending anomaly. Probably caused by a mapped storm drain.	No
230W Line 15N	9			X		Anomaly probably caused by a small shallow metallic object.	Yes
280W - 310W 10N & 15N	10	X	X	X	X	Large anomalous area coincides with an area in which a storm drain; water, electrical and sewer lines; a metal manhole cover; and a monitoring well are mapped.	No

Note: T = magnetic total field
 C = EM-31 conductivity
 I = EM-31 in-phase

Table 17
Geophysical Anomaly Interpretation, Site 3 (Parking Lot South of Bldg. 37)

General Anomaly Location	Anomaly reference number	Magnetometer		EM-31		GPR	Anomaly Description and Interpretation	Further action required? Yes/No
		T	G	C	I			
(60W-100W, 00N)	1	X	X	X		X	A plus-minus total field magnetic and EM-31 in-phase anomaly. An EM-31 conductivity low and magnetic gradient high anomaly. Anomaly probably caused by steel grate located at (80W,02N).	No
(65W,35N)	2	X	X		X		Positive magnetic anomalies and a small EM-31 in-phase anomaly in the general location. Indicative of buried ferrous material.	Yes
(00W,00N)	3		X	X			Anomaly probably caused by a metal rebar in concrete walk.	No
(20W-100W, 60N)	4	X				X	Strong negative anomaly probably caused by unknown ferrous object.	Yes
(150W,15N)	5	X	X	X	X	X	A large broad anomaly detected by all methods. May be caused by buried ferrous material.	Yes
(180W,60N)	6	X	X	X	X		Anomaly probably due to buried ferrous objects.	Yes
(05W,60N)	7		X	X	X	X	Anomaly caused by monitoring well.	No
(20W,60N) to (180W,60N)	8			X			High conductivity anomaly along northern portion of parking lot. May be caused by sidewalk or buried utility line. The other geophysical methods detected discrete anomalies in the same general area as mentioned above.	No
(25W,25N)	9				X	X	Anomaly may be caused by shallow and/or small buried metallic object.	No
(125W,00N)	10				X		Anomaly may be caused by a nearby steel sign.	No

Note: T = magnetic total field
 G = magnetic gradient
 C = EM-31 conductivity
 I = EM-31 in-phase

Table 18 Geophysical Anomaly Interpretation, Site 4 (Parking Lot West of Bldg. 39)							
General Anomaly Location	Anomaly reference number	Mag	EM-31		GPR	Anomaly Description and Interpretation	Further action required? Yes/No
		T	C	I			
(05W,00N) to (05W,120N)	1			X		Elongated negative north-south trending anomaly along eastern edge of parking lot. Probably caused metal grates and/or buried drain pipe.	No
(10W,20N) to (10W,70N)	2	X	X	X	X	This anomaly is probably caused by metal grates and/or buried drain pipe.	No
(20W,60N) to (60W,60N)	3	X	X	X		Elongated east-west trending anomaly may be caused by buried ferrous utility (drain pipe, water pipe, steam line, etc.) or by rebar in concrete walk.	Yes
(00W,00N) to (150W,00N)	4	X	X	X		An east-west trending anomaly is probably caused by an east-west steel perimeter fence located 12 ft from the southern portion of the site. Any buried ferrous utility line or object would probably be masked by the influence of the steel fence on the local magnetic field.	No
(40W,120N) to (150W,50N)	5	X	X	X	X	The EM-31 anomaly is a large broad elongated anomaly approximately 30 ft wide. The magnetometer anomaly overlaps the EM-31 anomaly and covers the whole northwest portion of the site. The anomaly is caused by ferrous material which may be associated with buried rubble, an unmapped tunnel, unmapped utility lines, infilled trench, etc.	Yes

Note: T = magnetic total field
 C = EM-31 conductivity
 I = EM-31 in-phase

Table 19**Geophysical Anomaly Interpretation, Site 5 (Parking Lot South of Bldg. 243)**

General Anomaly Location	Anomaly reference number	Mag	EM-31		GPR	Anomaly Description and Interpretation	Further action required? Yes/No
		T	C	I			
(50E,20N)	1	X	X			Anomaly probably caused by steel stop sign located at approximately (55E,15N) and/or steel manhole cover located at approximately (35E,22N).	No
(25E,20N)	2		X	X	X	This anomaly is most likely caused by a metal manhole cover located at approximately (35E,22N).	No
(10E-50W, 40N)	3	X	X	X		The EM-31 positive anomalies and the magnetic plus-minus anomaly is probably caused by metal rebar in concrete drive in front of Bldg. 243 and/or the metal in the building.	No
(80W,40N)	4	X	X	X		Anomaly probably caused by a buried ferrous object in the vicinity, possibly a catch basin.	Yes
(00W,00N)	5	X	X	X		Anomaly probably caused by a buried ferrous object.	Yes
(20E,20N) to (90W,20N)	6	X				Elongated east-west trending anomaly. May be caused by buried utility.	Yes

Note: T = magnetic total field
 C = EM-31 conductivity
 I = EM-31 in-phase

5 Conclusions and Recommendations

A geophysical investigation was conducted at five sites at the U.S. Army Materials Technology Laboratory. The purpose of the investigation was to determine any evidence of soil disturbance indicative of fill material at Sites 1 and 2, the presence of an underground storage tank at Site 3, and any evidence suggesting the presence of unmapped underground lines capable of carrying wastes off the Laboratory boundaries at Sites 4 and 5. Magnetic, electromagnetic, and ground penetrating radar methods were employed to meet these objectives. Numerous geophysical anomalies were interpreted for each site. However, many of these anomalies were attributable to visible or mapped objects capable of interfering with the geophysical tests. Maps showing the locations of the interpreted anomaly locations, along with a corresponding anomaly reference number, were constructed for each site. The areas requiring further action were defined for each site.

The anomalous areas that should be considered for further action include:

- a. Site 1 - Anomaly numbers 2, 4, 5, and 6
- b. Site 2 - Anomaly numbers 5, 6, and 9
- c. Site 3 - Anomaly numbers 2, 4, 5, and 6
- d. Site 4 - Anomaly numbers 3 and 5
- e. Site 5 - Anomaly numbers 4, 5, and 6

References

- Barrows, L., and Rocchio, J.E. (1990). "Magnetic surveying for buried metallic objects," *Ground Water Monitoring Review* 10(3), 204-11.
- Bevan, B.W. (1983). "Electromagnetics for mapping buried earth features," *Journal of Field Archaeology* 10, 47-54.
- Breiner, S. (1973). *Applications manual for portable magnetometers*. Geometrics, Sunnyvale, CA.
- Butler, D.K. (1986). "Military hydrology; Report 10: Assessment and field examples of continuous wave electromagnetic surveying for ground water," Miscellaneous Paper EL-79-6, U.S. Army Engineer Waterways Experiment Station, Vicksburg, MS.
- Butler, D.K., and Llopis, J.L. (1990). "Assessment of anomalous seepage conditions," in *Geotechnical and environmental geophysics, Volume II: Environmental and groundwater*. Soc. Explo. Geoph., Tulsa, OK.
- Geonics Limited. (1984). *Operating manual for EM31-D non-contacting terrain conductivity meter*. Mississauga, Ontario, Canada.
- McNeil, J.D. (1980). "Electromagnetic terrain conductivity measurements at low induction numbers," Technical note TN-6, Geonics Limited, Mississauga, Ontario, Canada.
- Nabighian, M.N. (1988). *Electromagnetic methods in applied geophysics-Theory, Vol. 1*. Soc. Explo. Geoph., Tulsa, OK.
- Olhoeft, G.R. (1984). "Applications and limitations of ground penetrating radar," *54th Ann. Internat. Mtg., Soc. Explo. Geoph.*, Expanded Abstracts, 147-8.
- Parasnis, D.S. (1966). *Mining geophysics*. Elsevier, New York.

Roy F. Weston, Inc. (1992). "Phase 2 remedial investigation report, Army Materials Technology Laboratory," Draft Final, West Chester, PA.

Telford, W.M., Geldhart, L.P., Sheriff, R.E., and Keys, D.A. (1973). *Applied geophysics*. Cambridge University Press, New York.

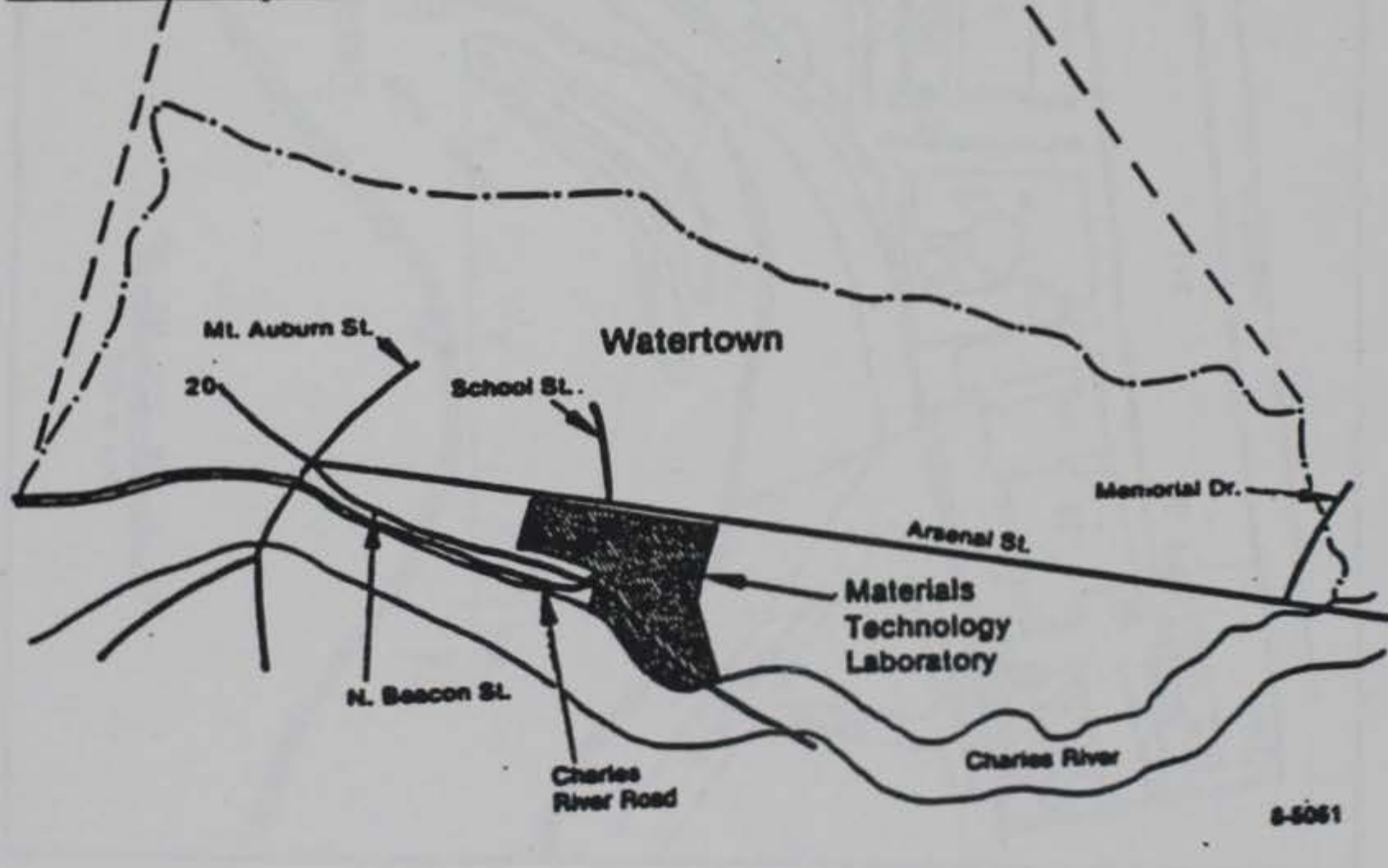
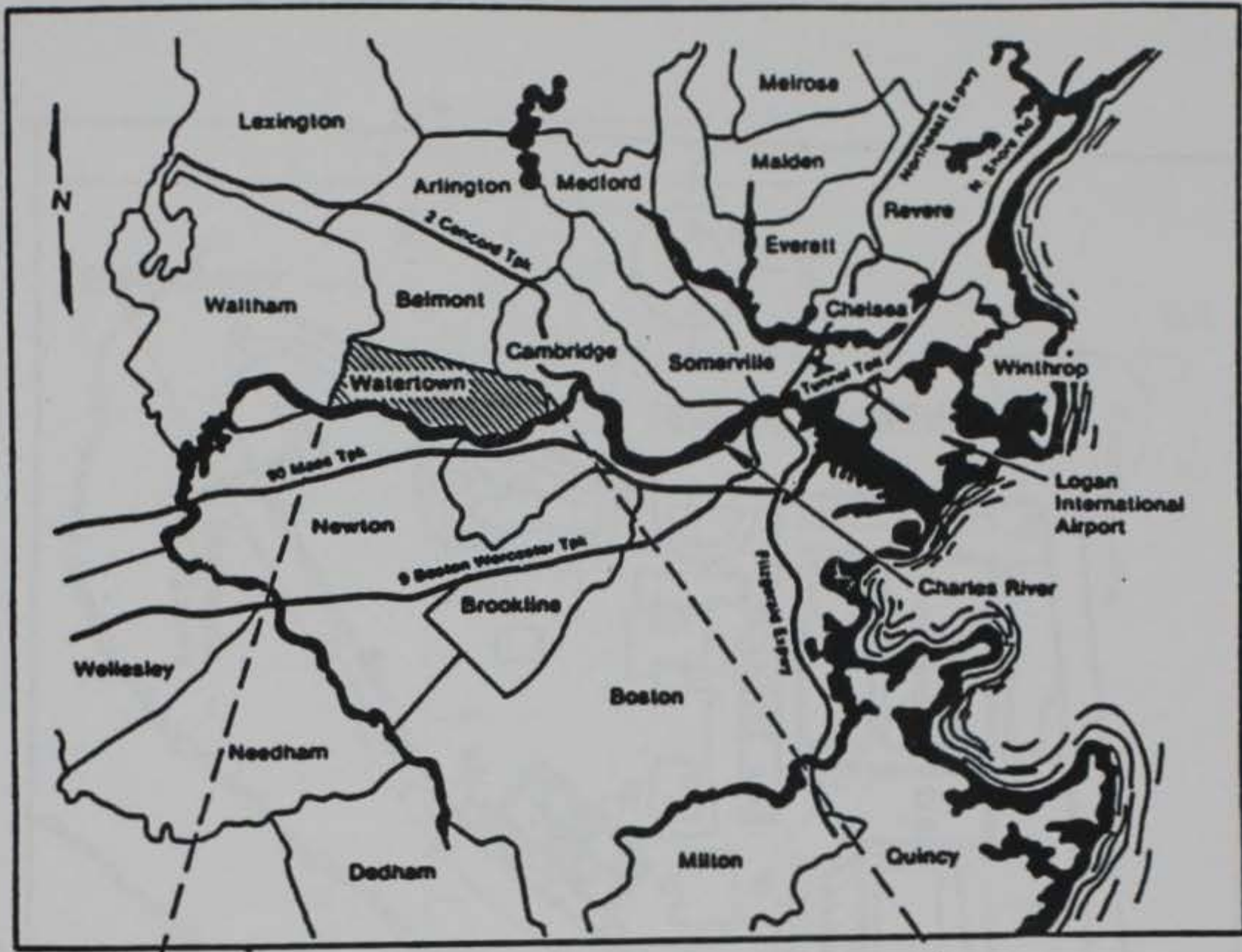

8-5051

Figure 1. Vicinity map

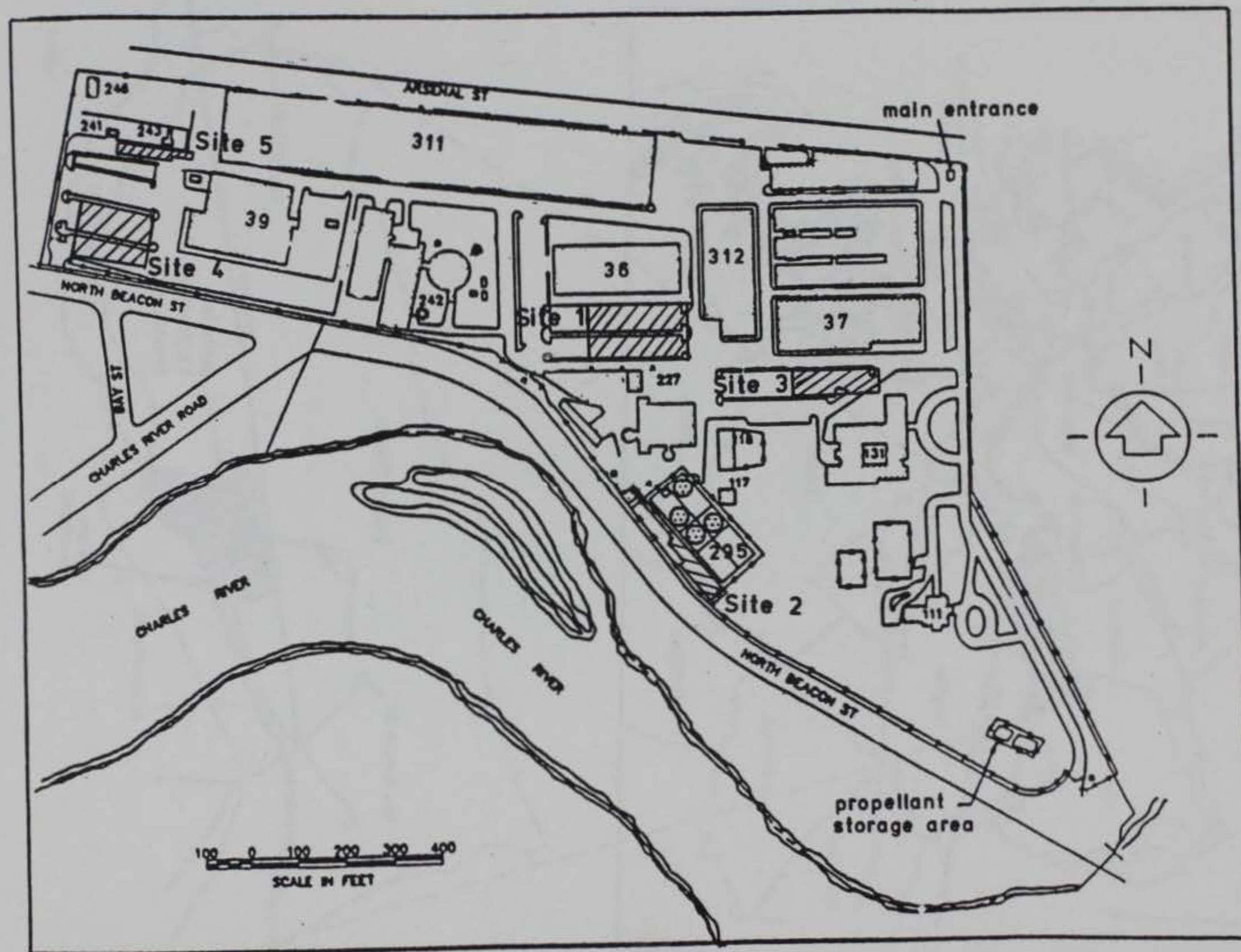

Figure 2. General site map

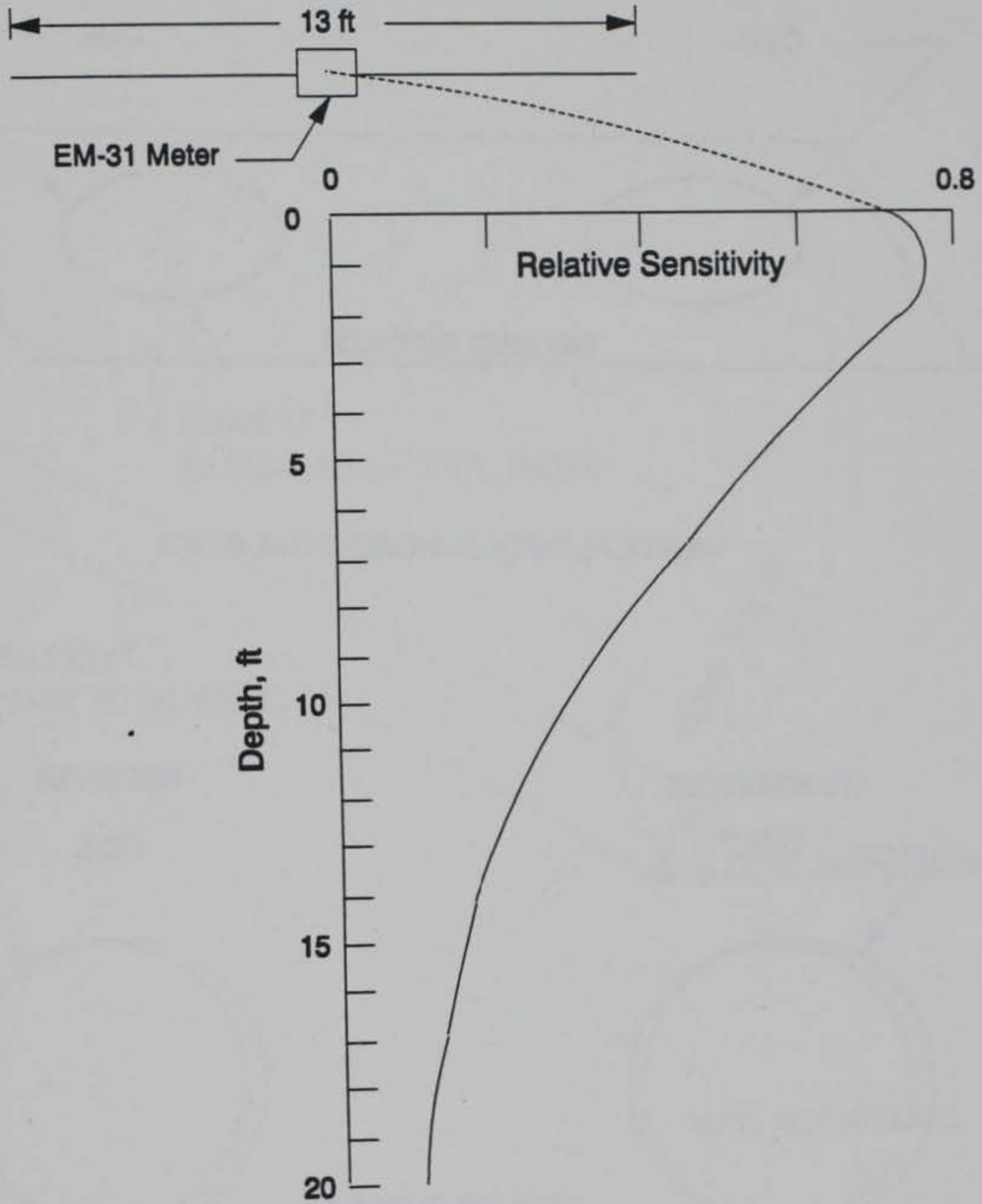
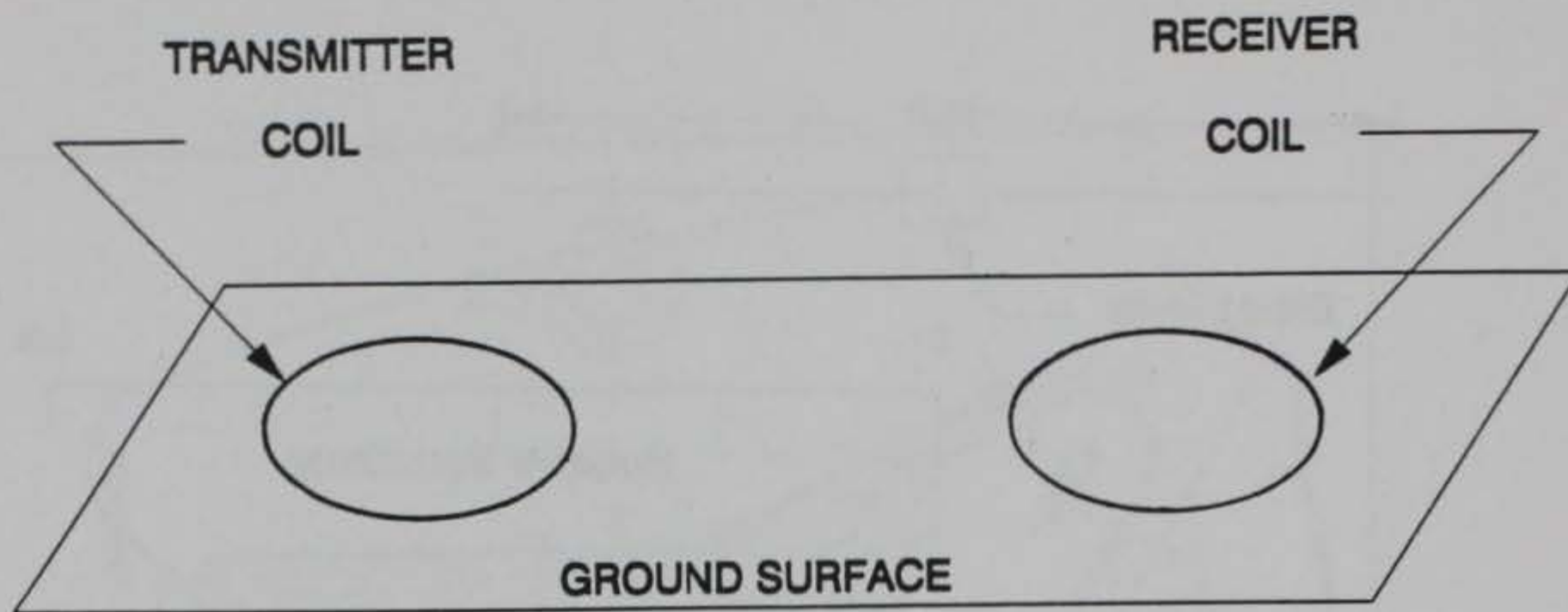
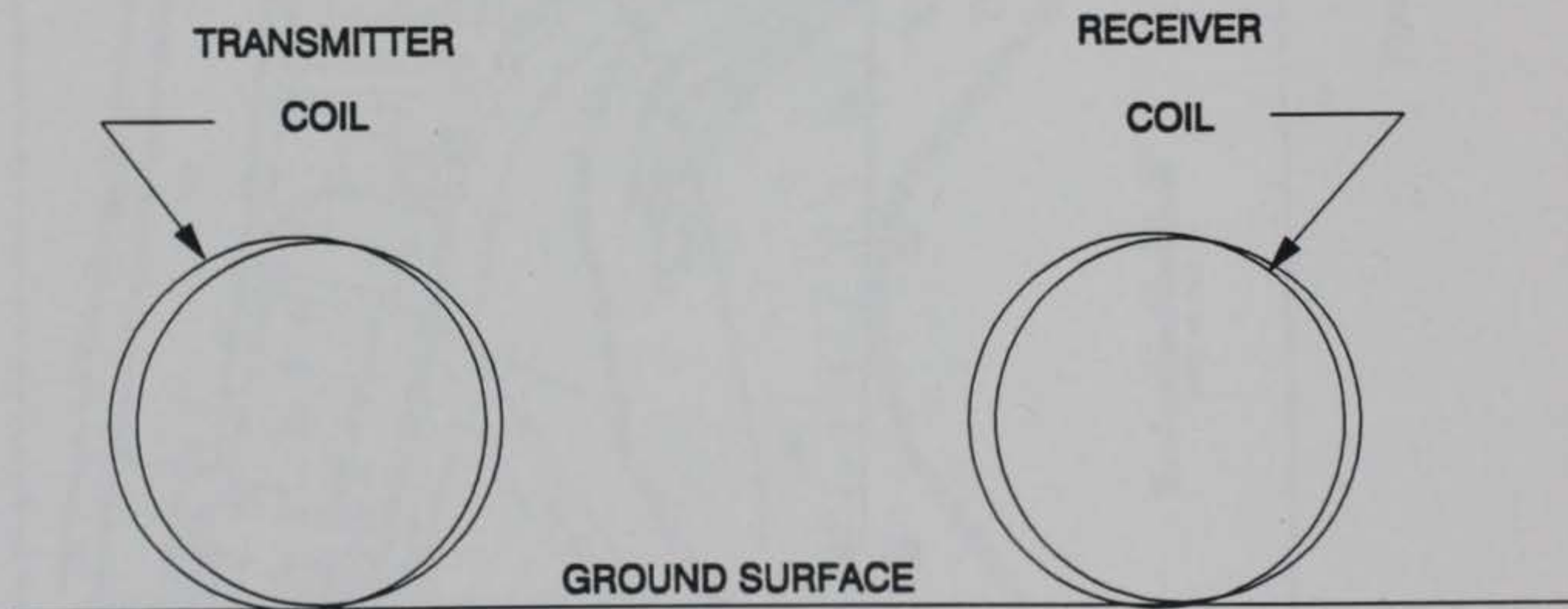

Figure 3. Sensitivity versus depth for the EM-31 terrain conductivity meter



VERTICAL DIPOLE - HORIZONTAL COILS



HORIZONTAL DIPOLE - VERTICAL COILS

Figure 4. Schematic illustration of the EM-31 transmitter and receiver coil orientations

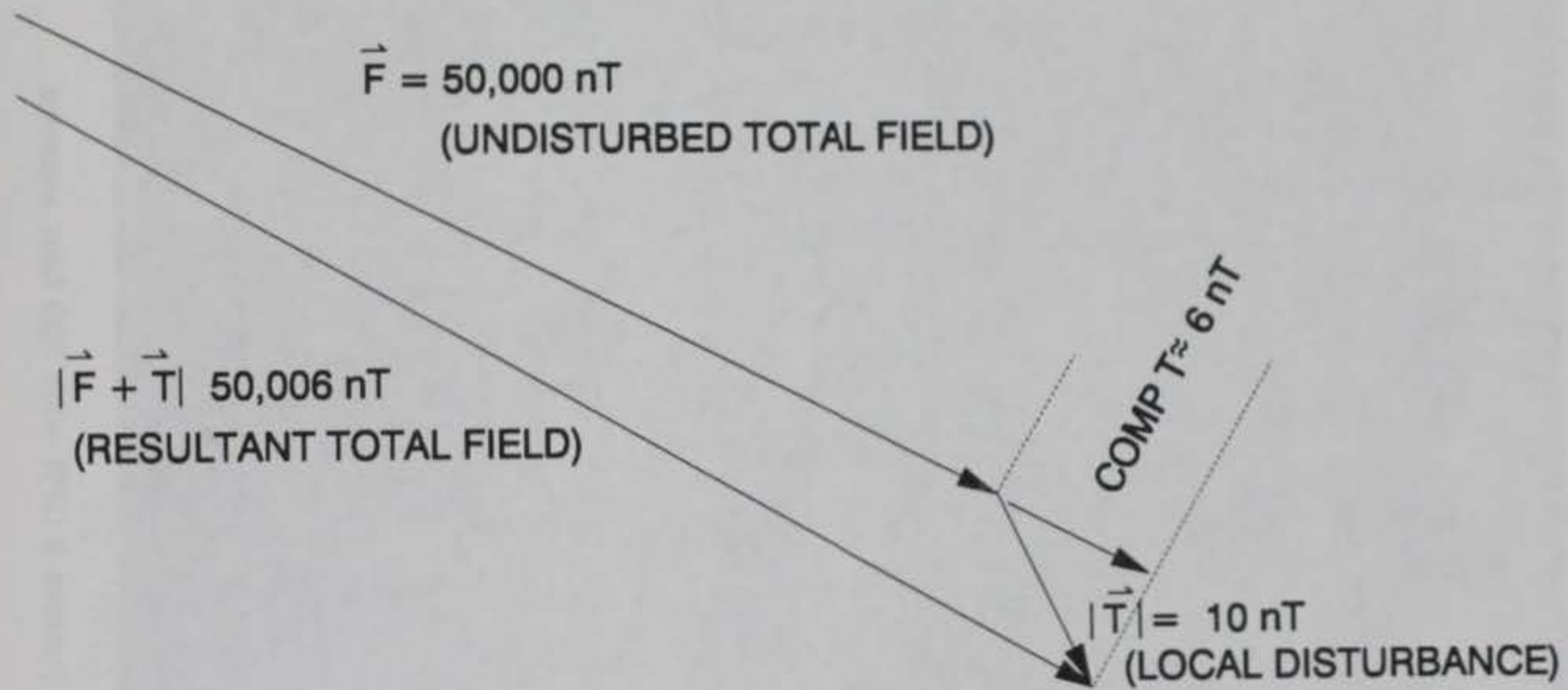

NOTE: NOT TO SCALE

Figure 5. Local perturbation of the total field vector (after Breiner, 1973)



Figure 6. GSSI System 8 GPR with 300 Mhz antenna

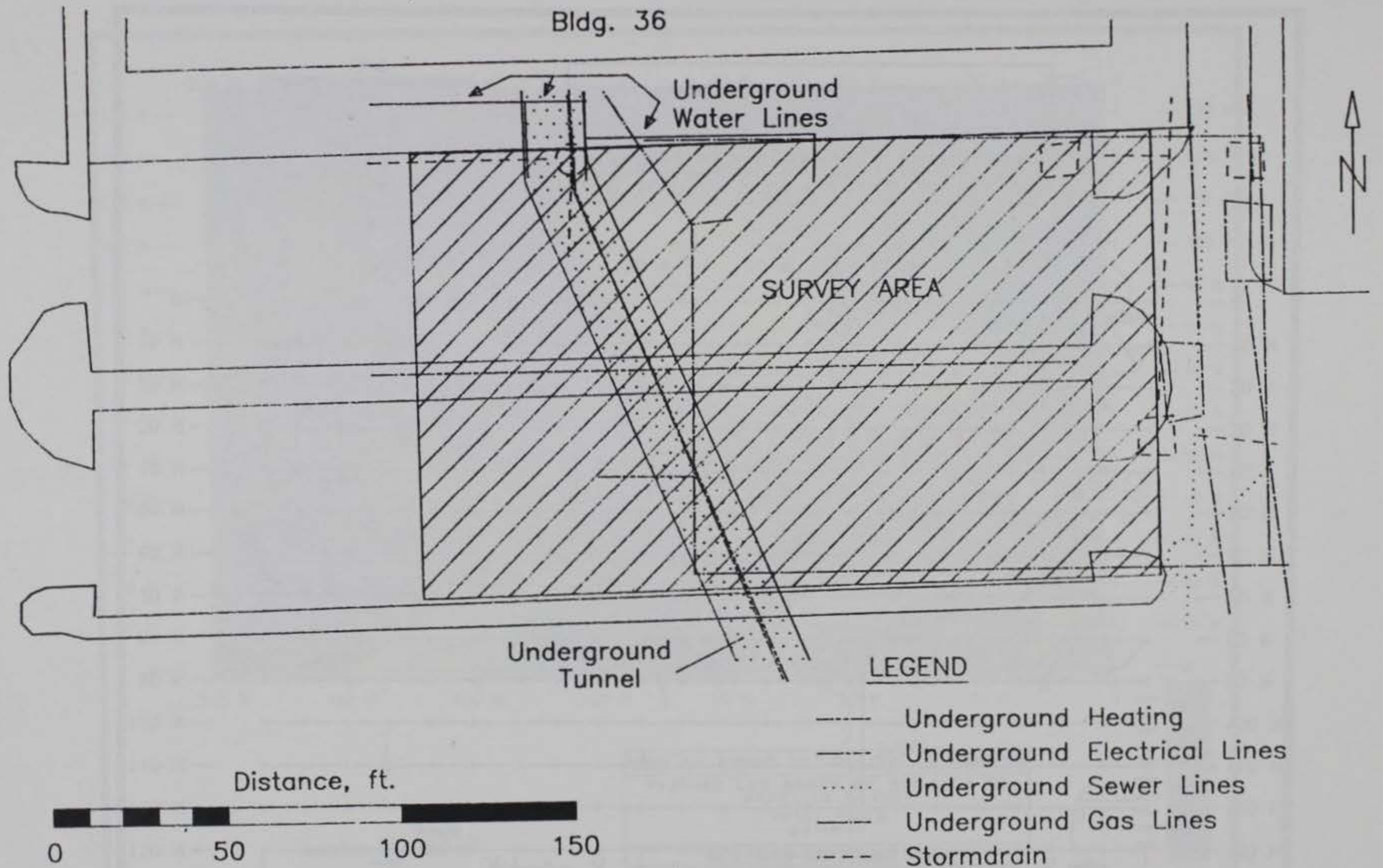

Figure 7. Site 1 map showing the area surveyed and location of underground utilities

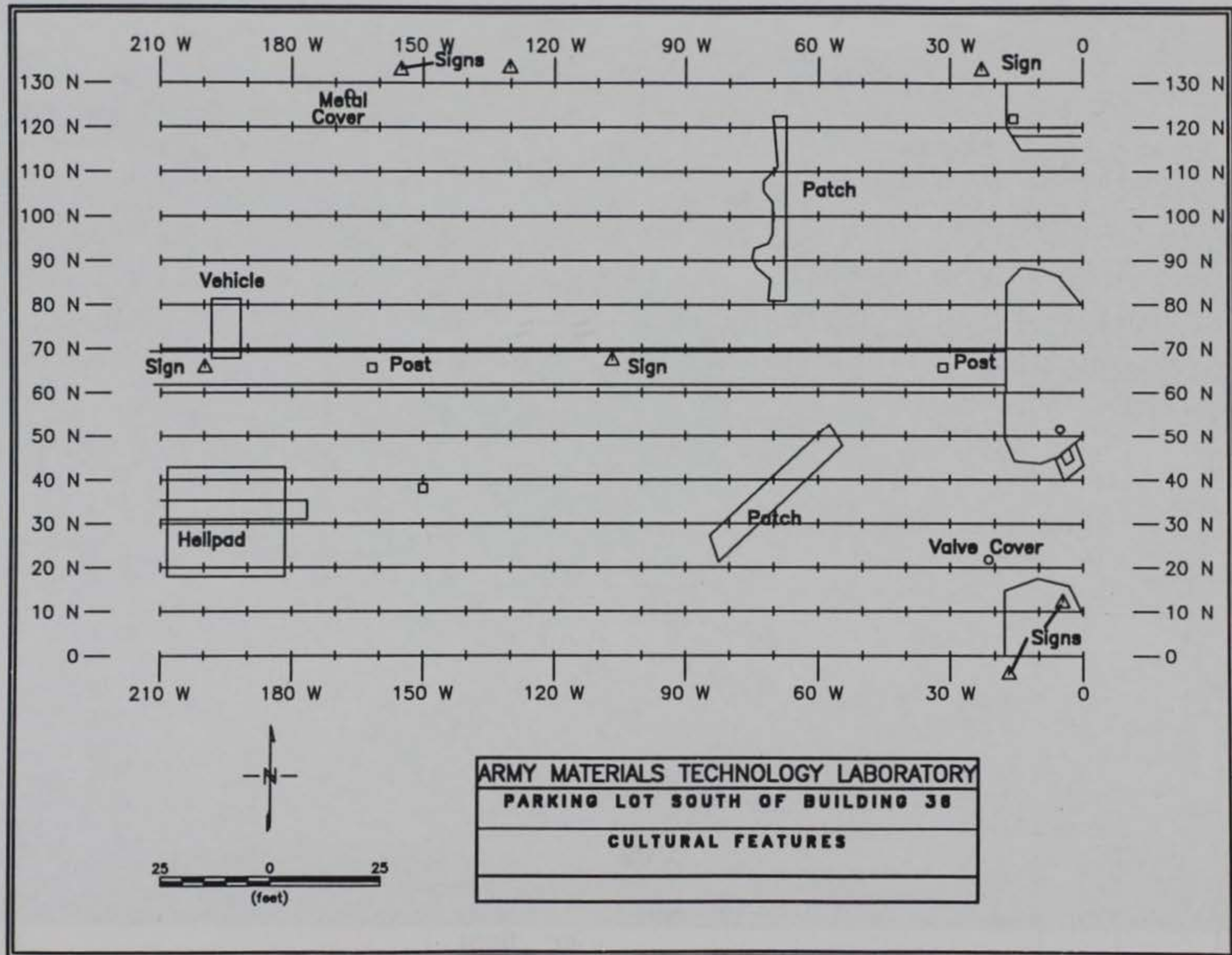

Figure 8. Site 1 survey grid layout and location of cultural features

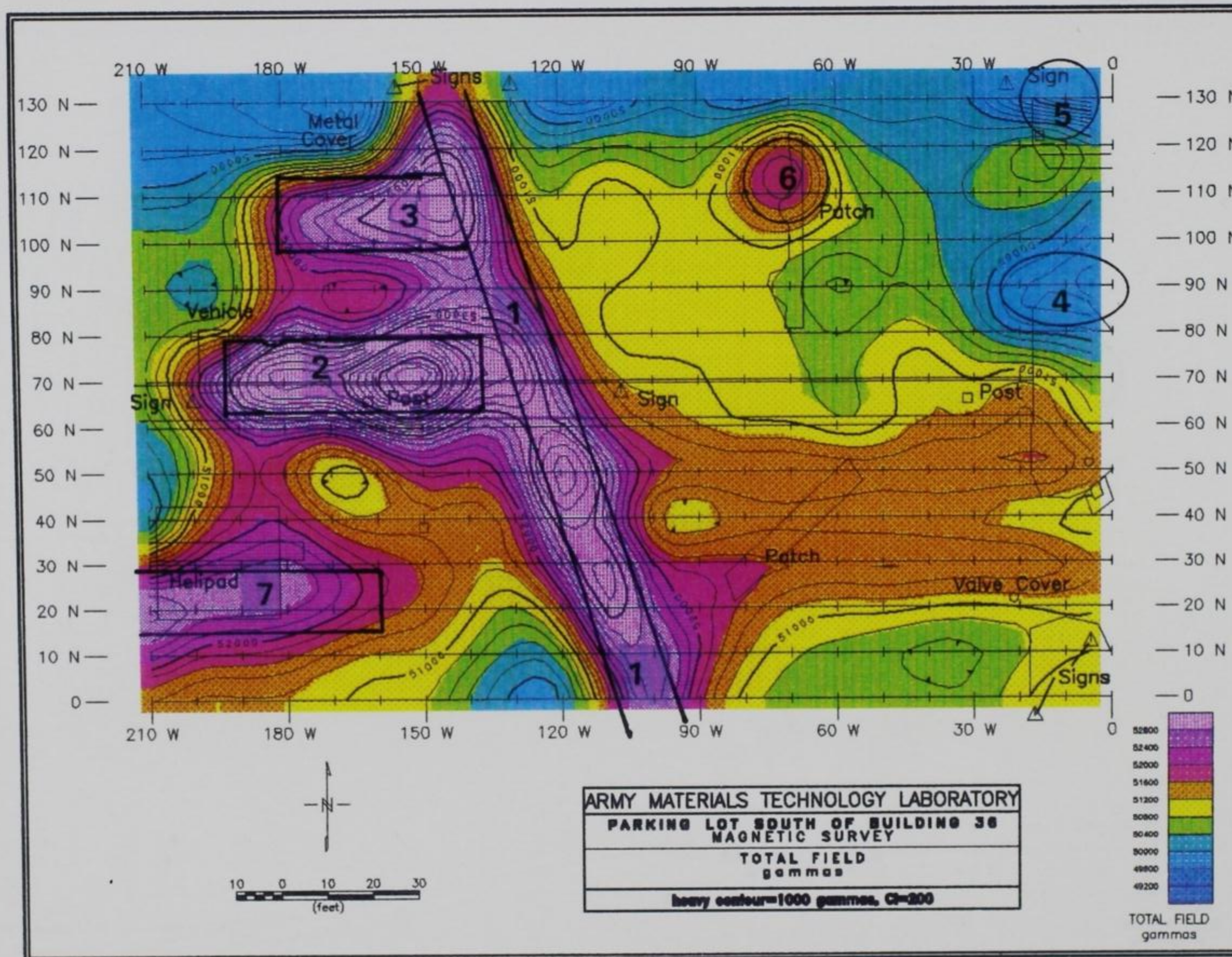

Figure 9. Results of magnetic total field survey, Site 1

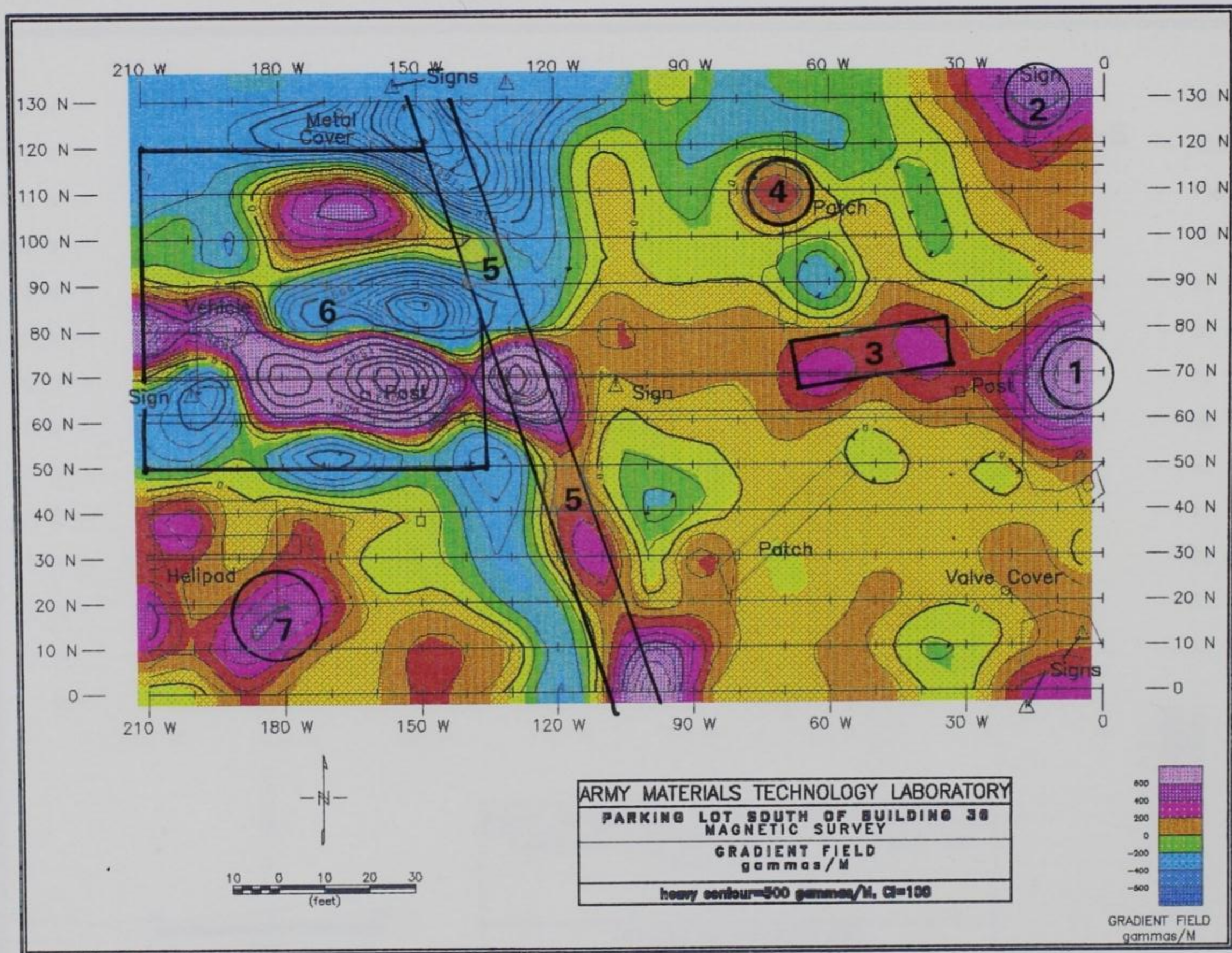

Figure 10. Results of magnetic gradient survey, Site 1

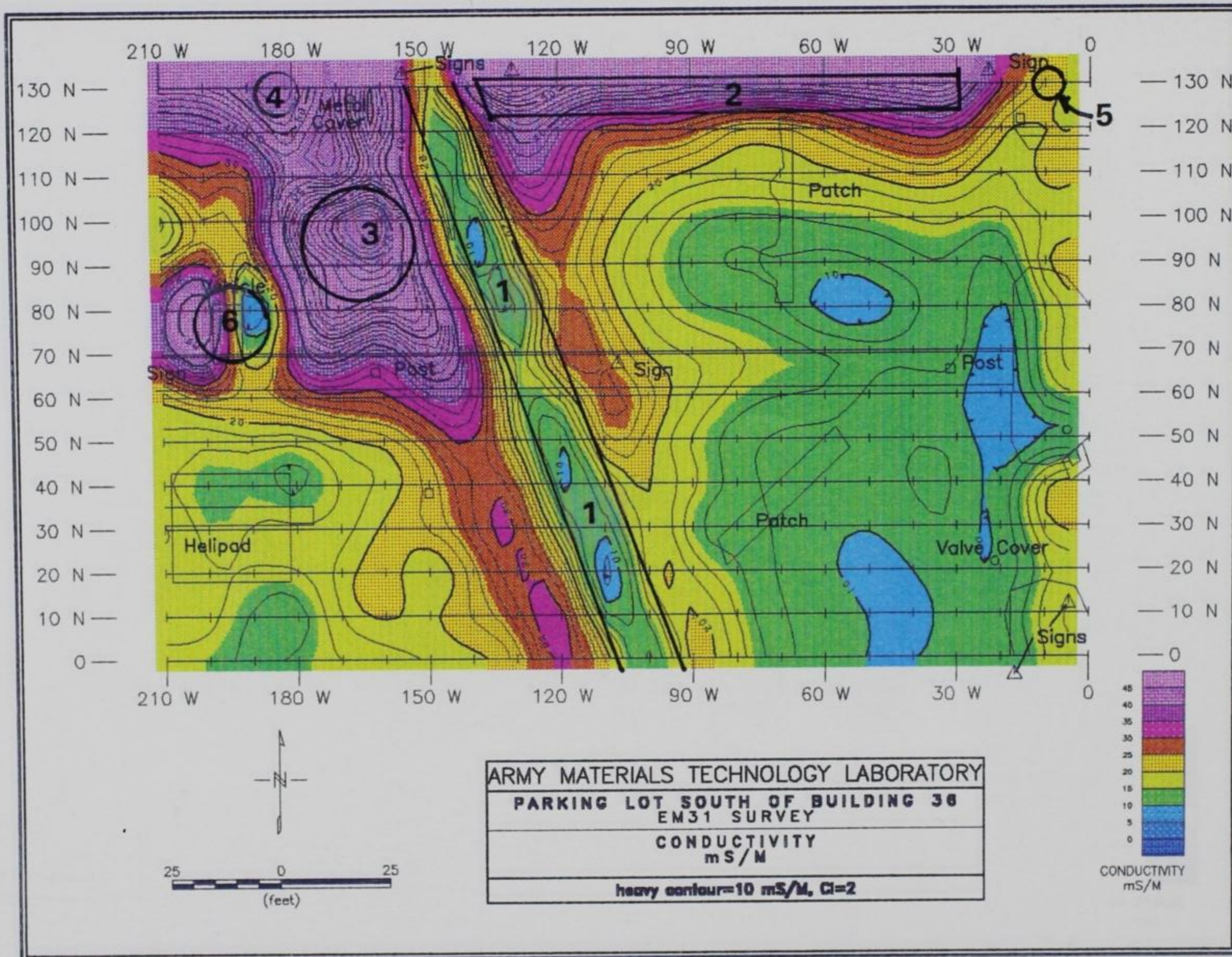

Figure 11. Results of EM-31 conductivity survey, Site 1

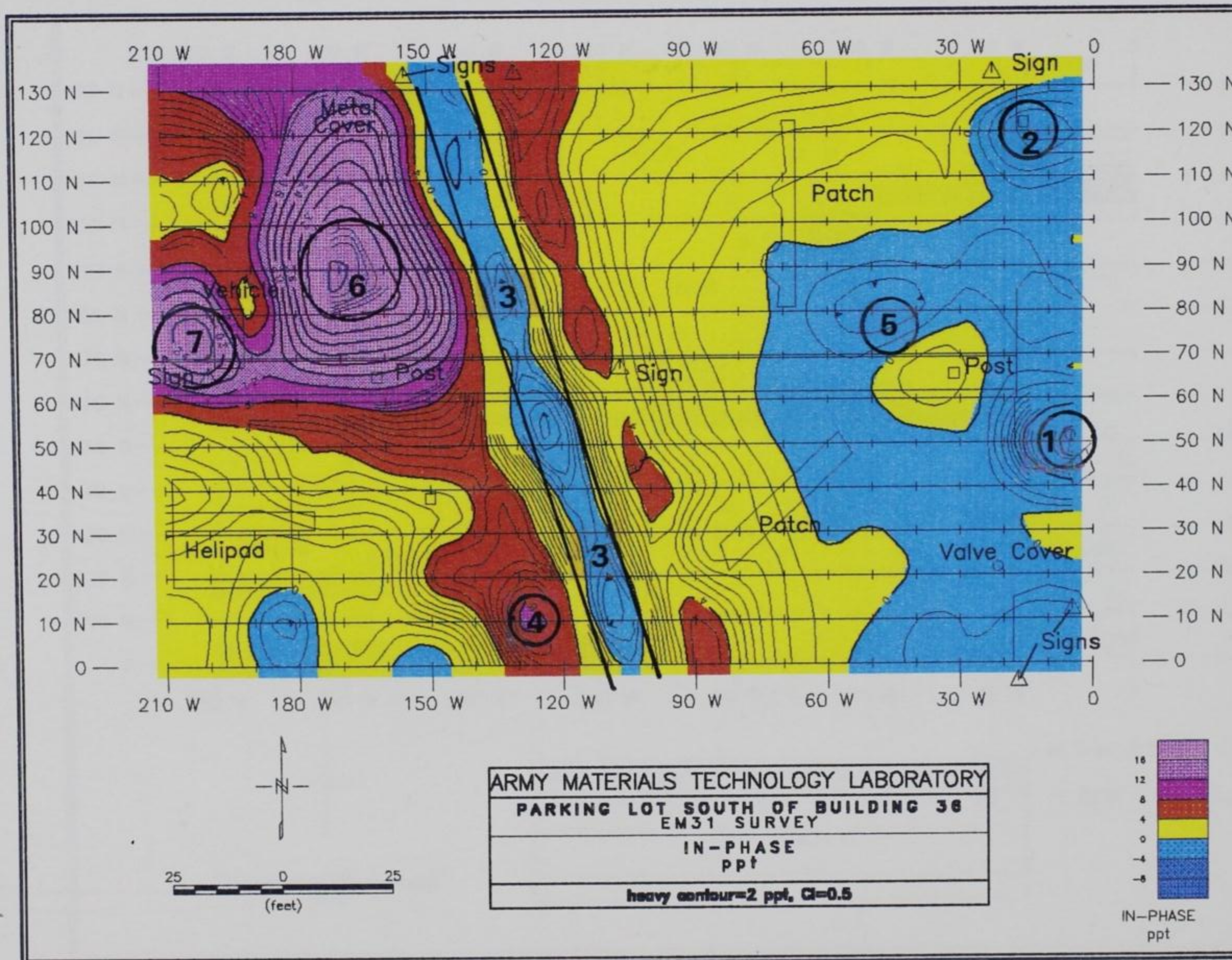

Figure 12. Results of EM-31 in-phase survey, Site 1

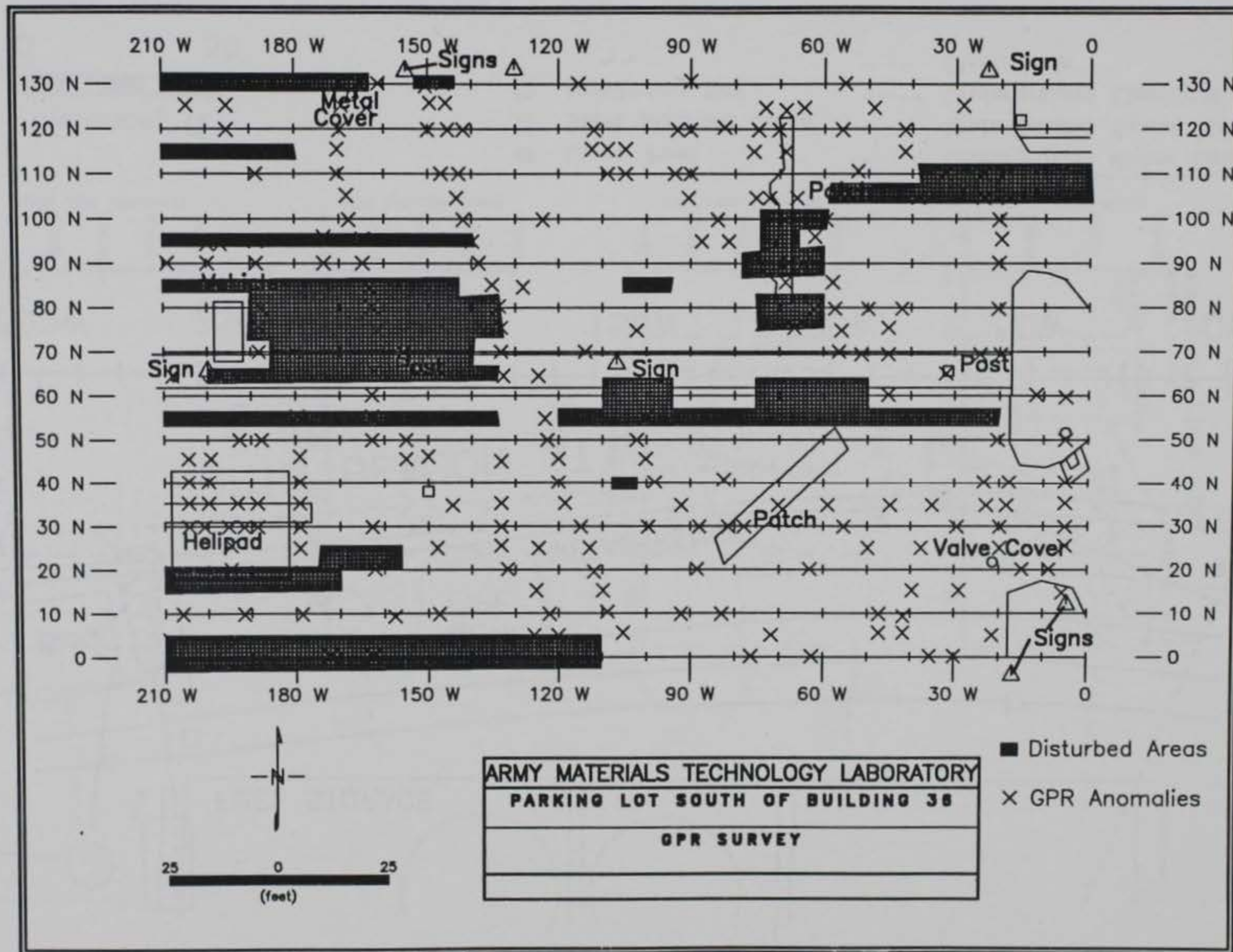
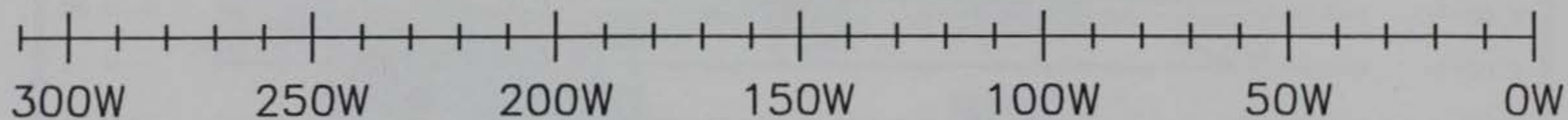
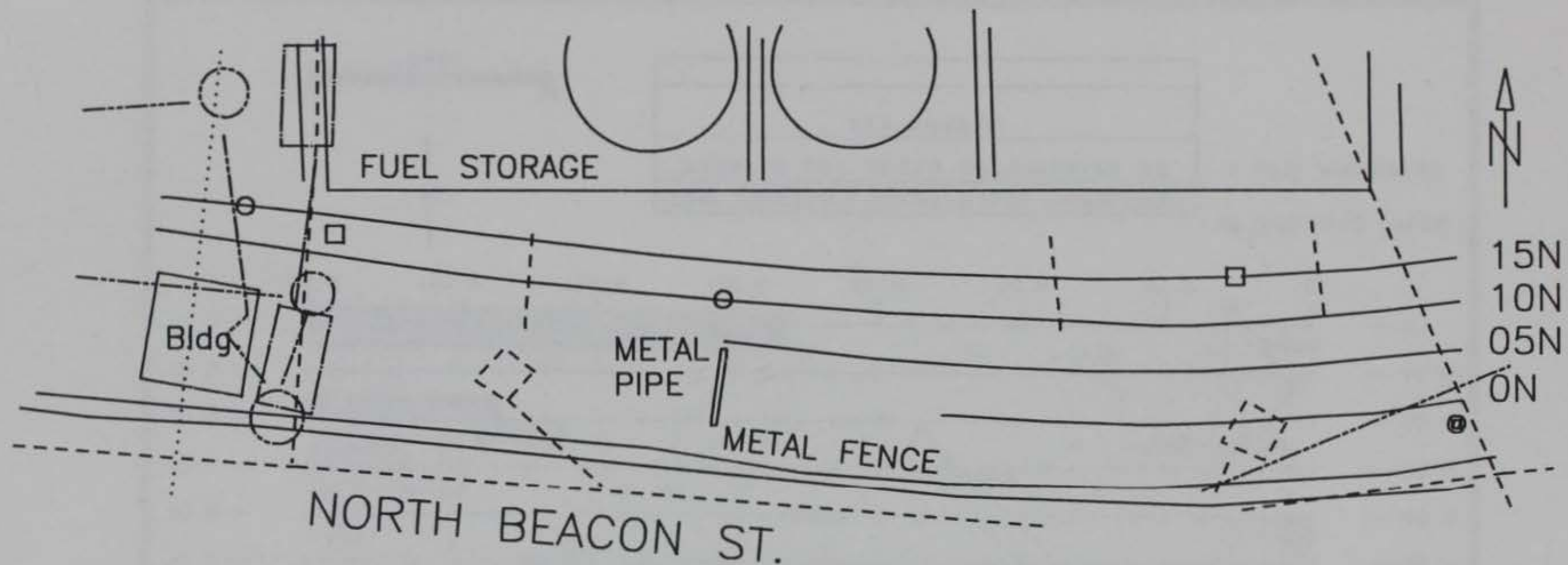

Figure 13. Results of GPR survey, Site 1



Distance, ft.

0 50

LEGEND

⊙	Lamp Post	Underground Water Lines
○	Steel Manhole Cover	-----	Underground Sewer Lines
□	Monitoring Well	————	Underground Electrical
		-----	Stormdrain

Figure 14. Site 2 test layout and location of cultural features and underground utilities

AREA ALONG SOUTH FENCE MAGNETIC SURVEY

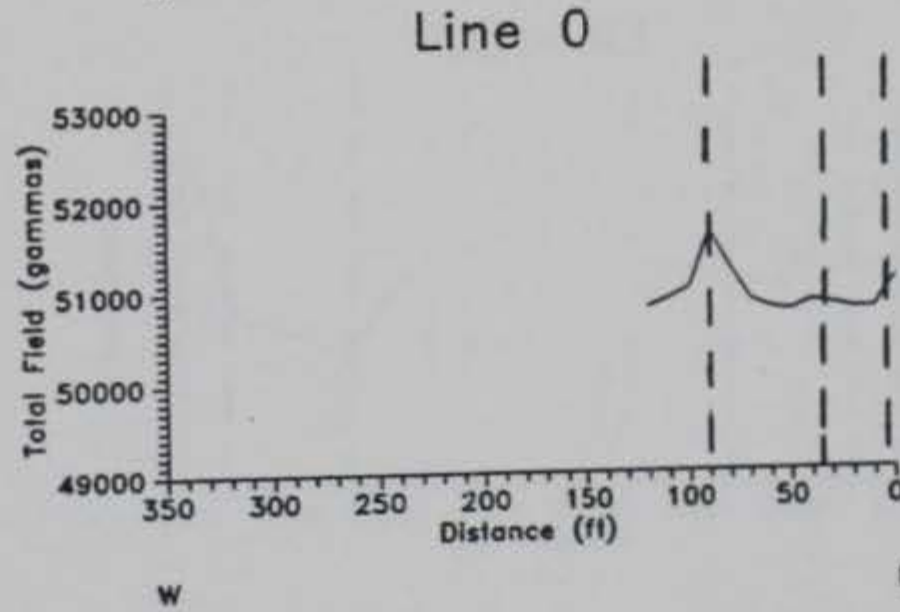
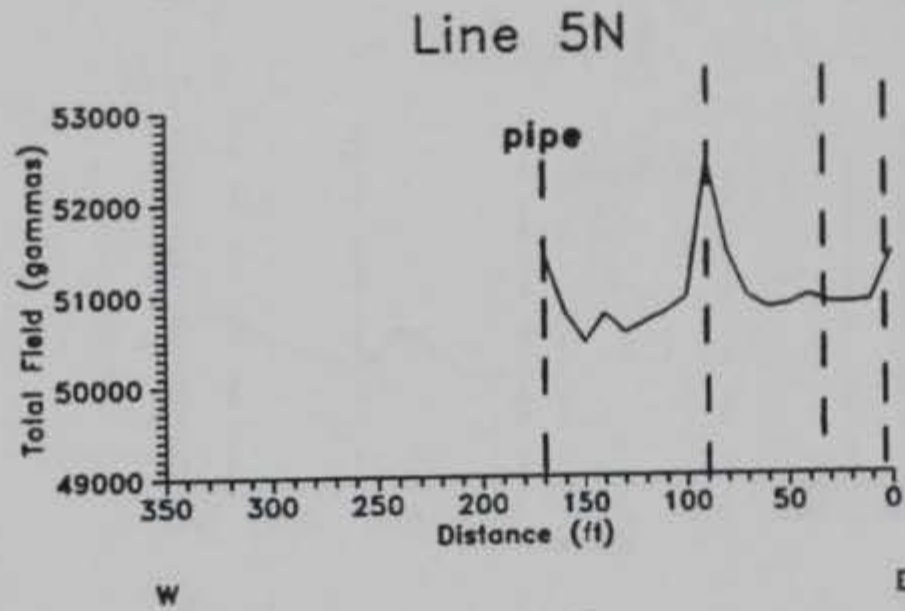
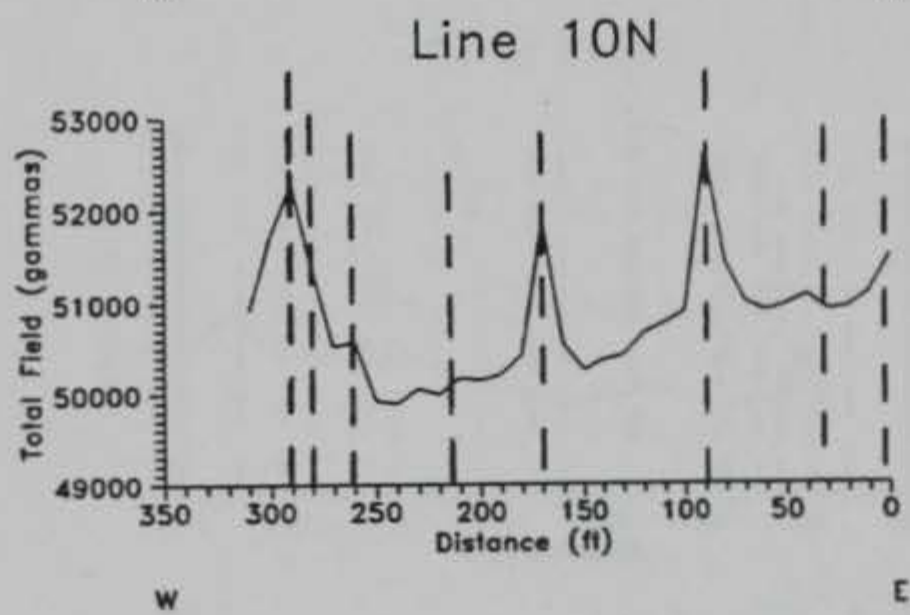
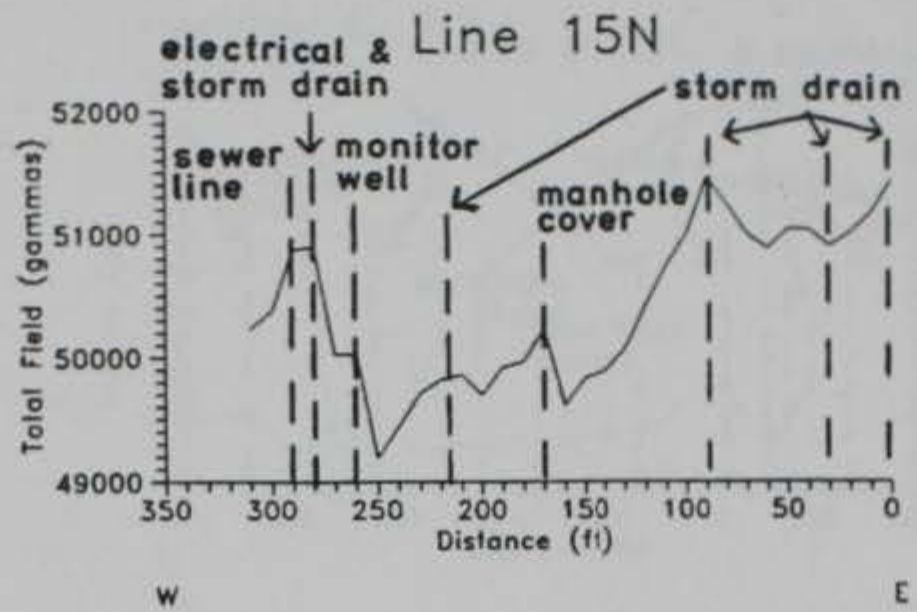

Figure 15. Results of magnetic total field survey, Site 2

AREA ALONG SOUTH FENCE EM31 SURVEY

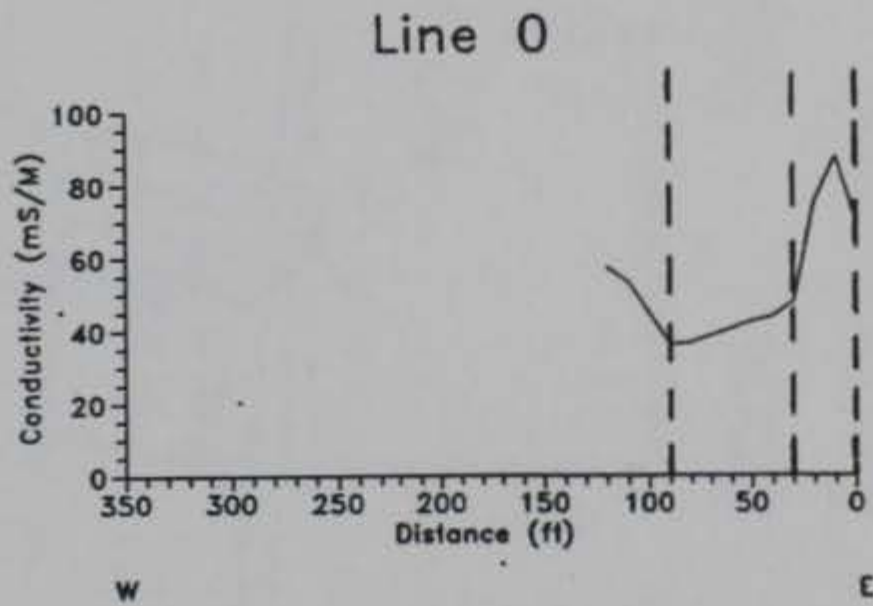
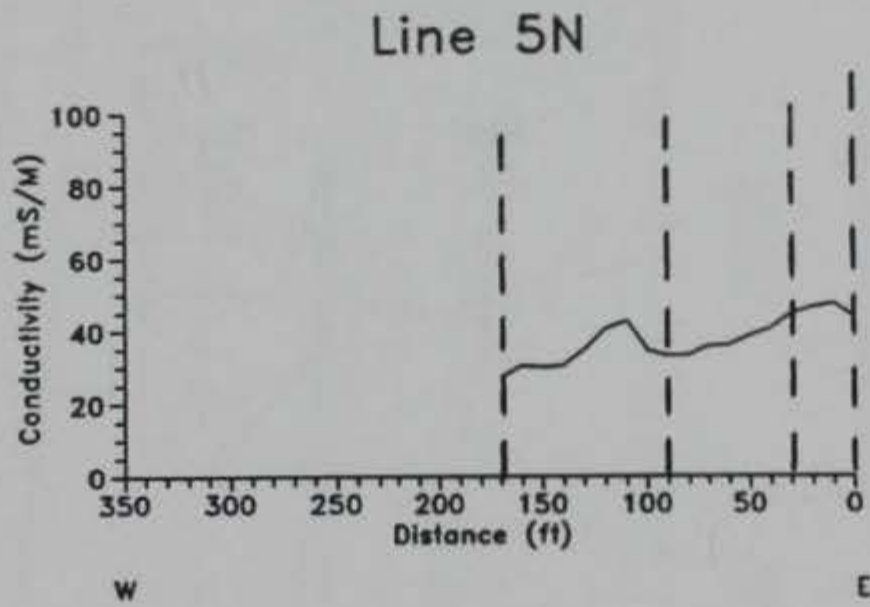
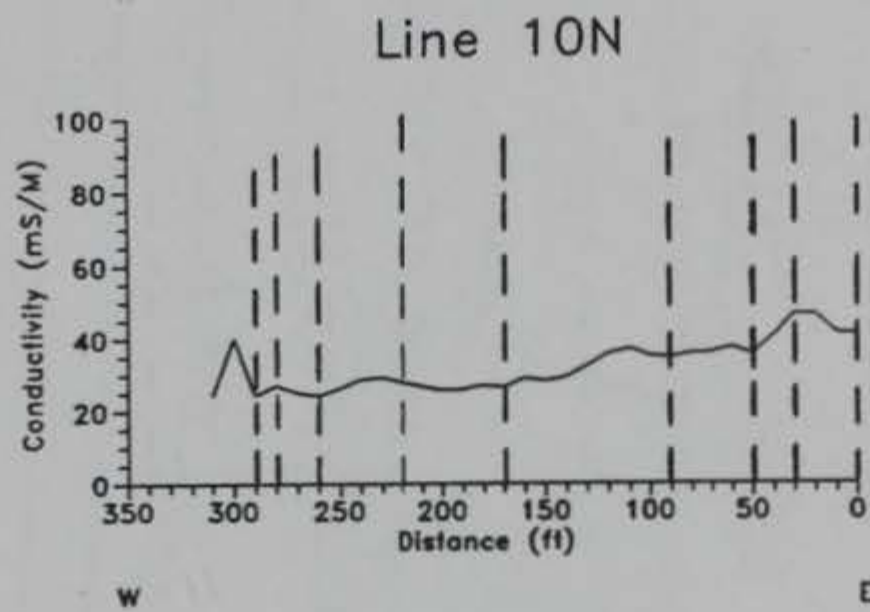
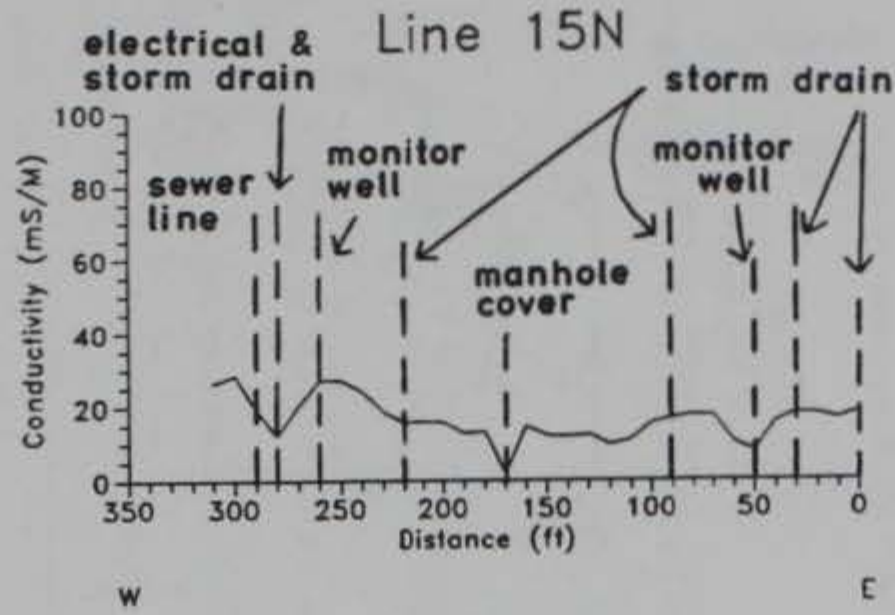

Figure 16. Results of EM-31 conductivity survey, Site 2

AREA ALONG SOUTH FENCE EM31 SURVEY

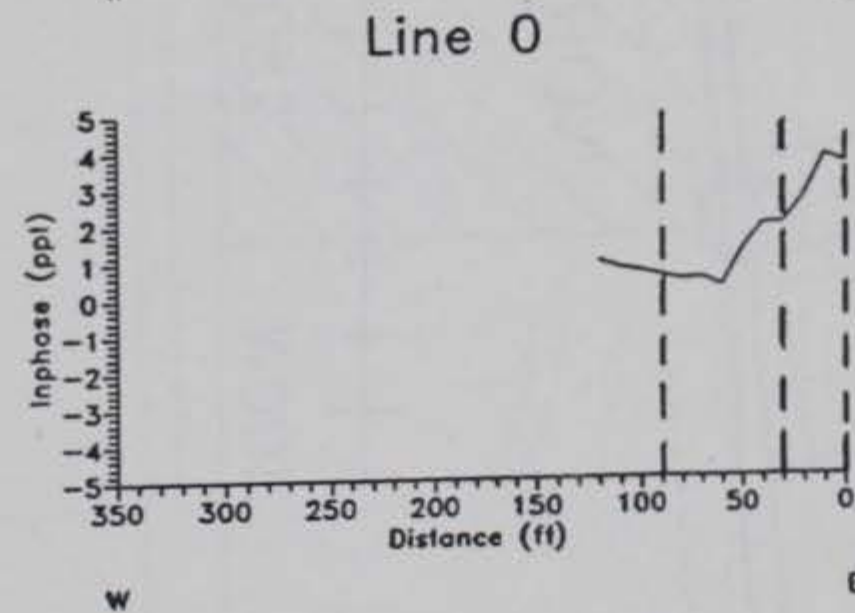
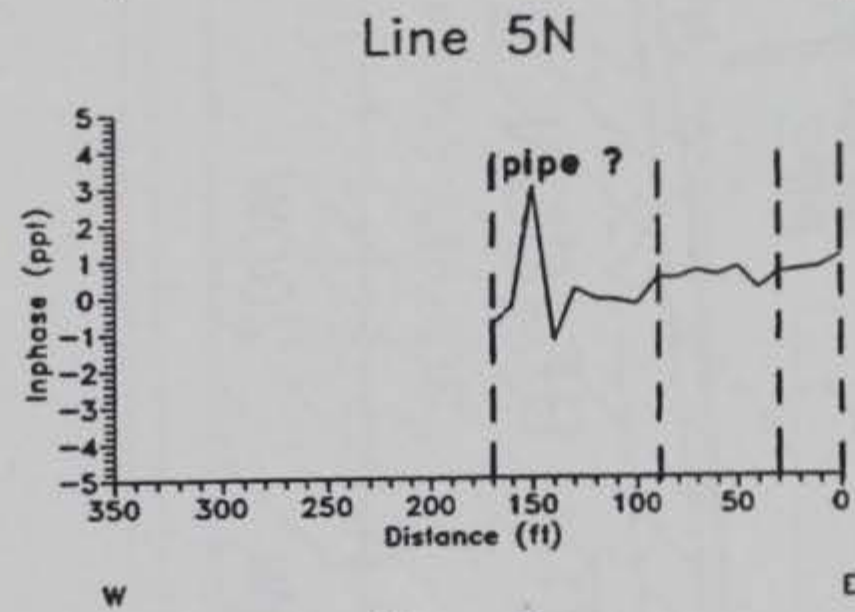
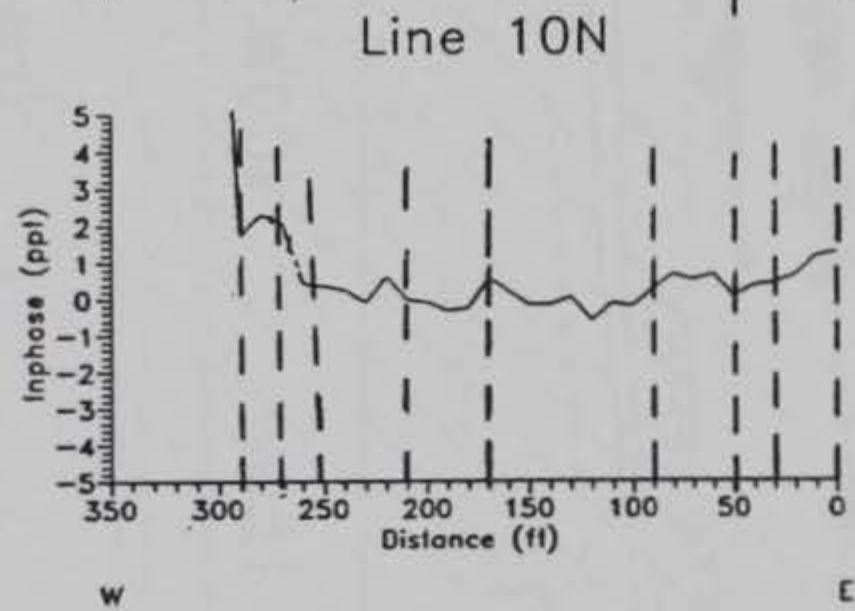
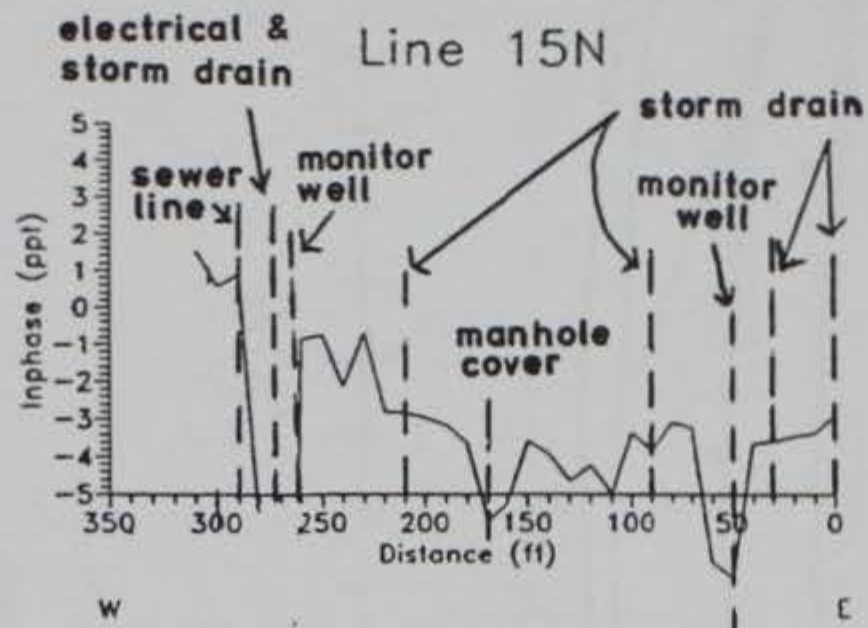
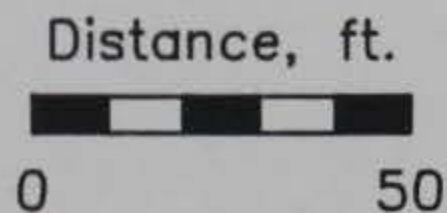
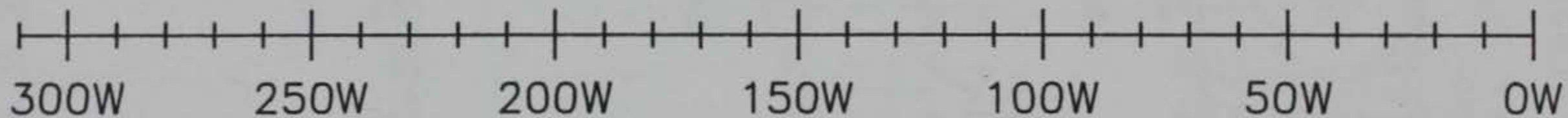
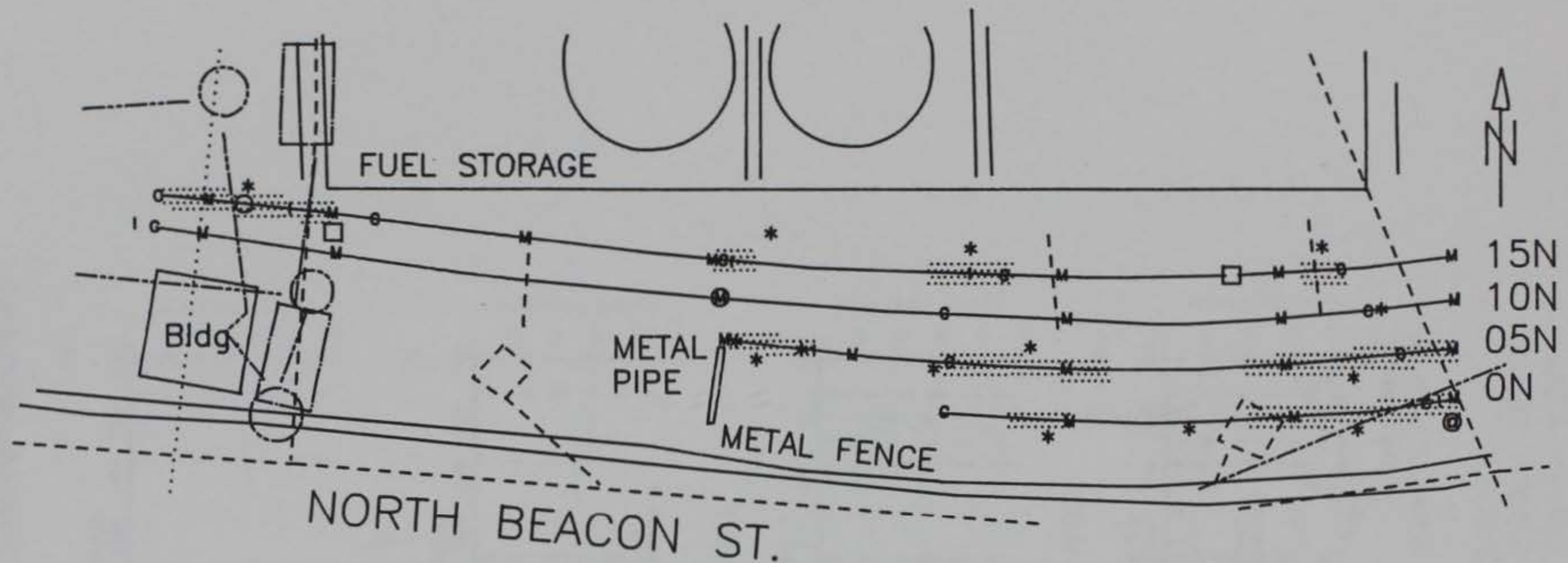

Figure 17. Results of EM-31 in-phase survey, Site 2



LEGEND

- | | | | |
|---|---------------------|---------|-------------------------|
| ⊙ | Lamp Post | | Underground Water Lines |
| ○ | Steel Manhole Cover | ----- | Underground Sewer Lines |
| □ | Monitoring Well | ——— | Underground Electrical |
| M | Magnetic Anomaly | - - - - | Stormdrain |
| ▨ | GPR Disturbed Area | C | Conductivity Anomaly |
| * | GPR Anomaly | I | Inphase Anomaly |

Figure 18. Results of GPR survey, Site 2

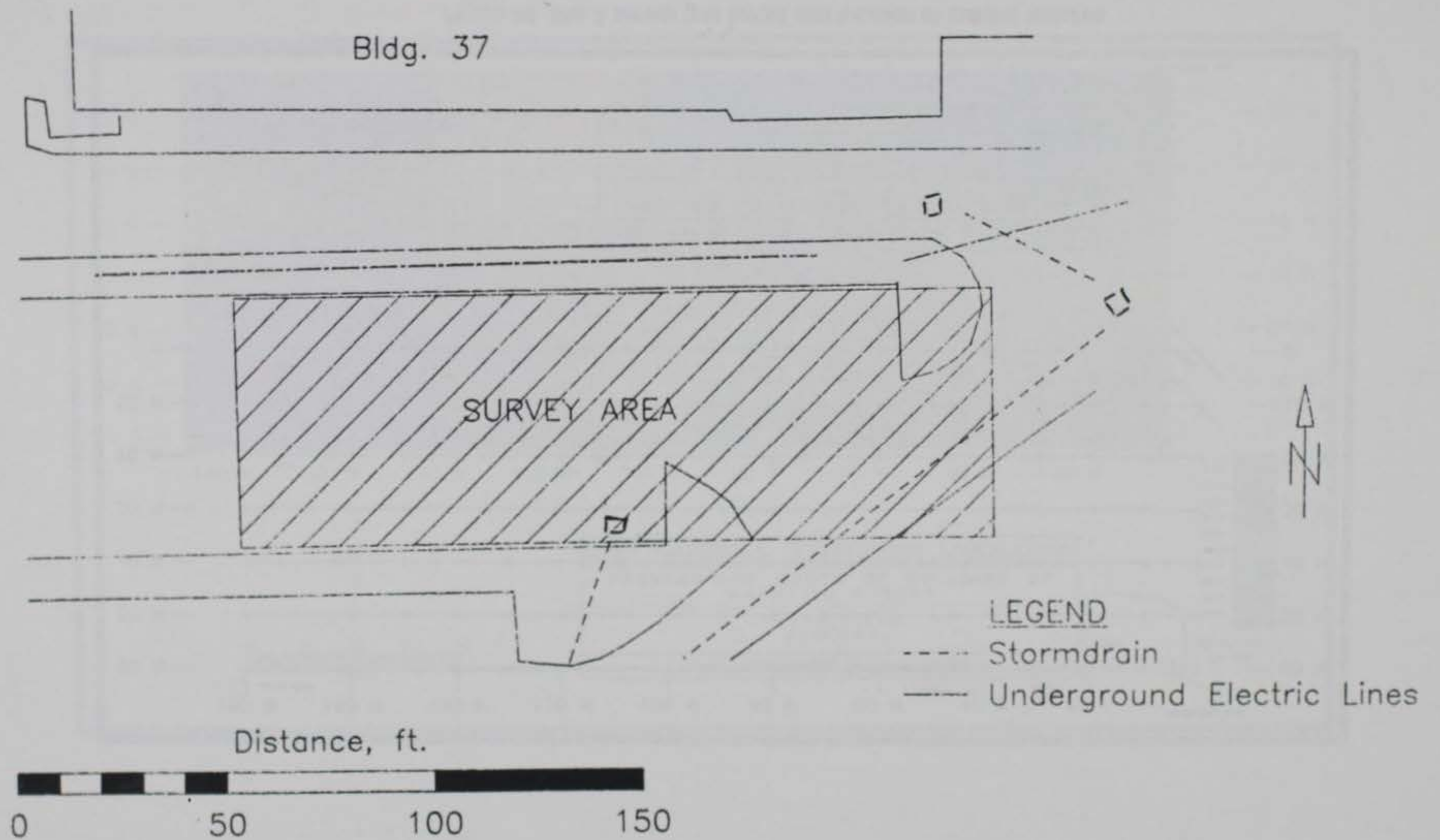

Figure 19. Map of Site 3 showing the area surveyed and location of underground utilities

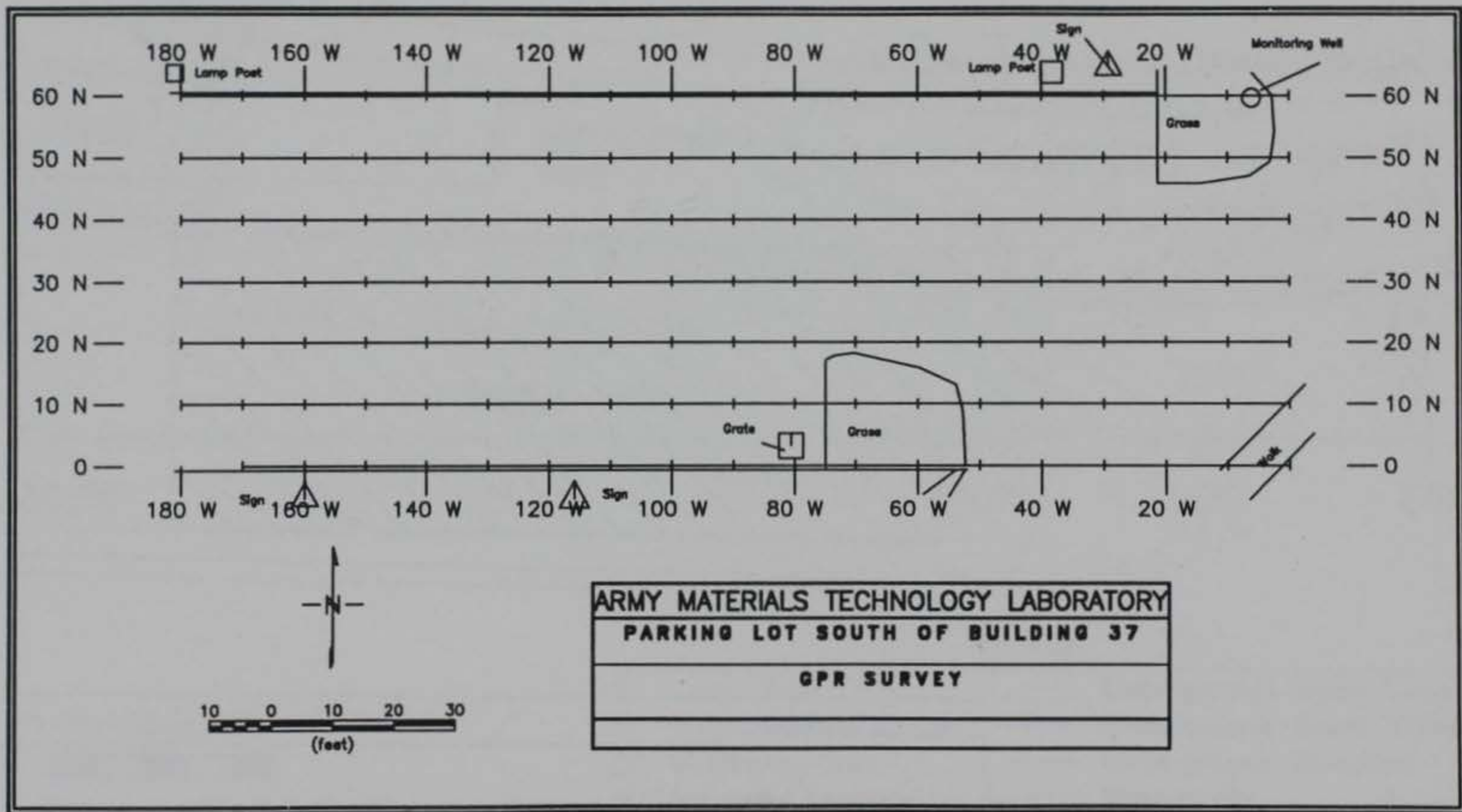

Figure 20. Site 3 survey grid layout and location of cultural features

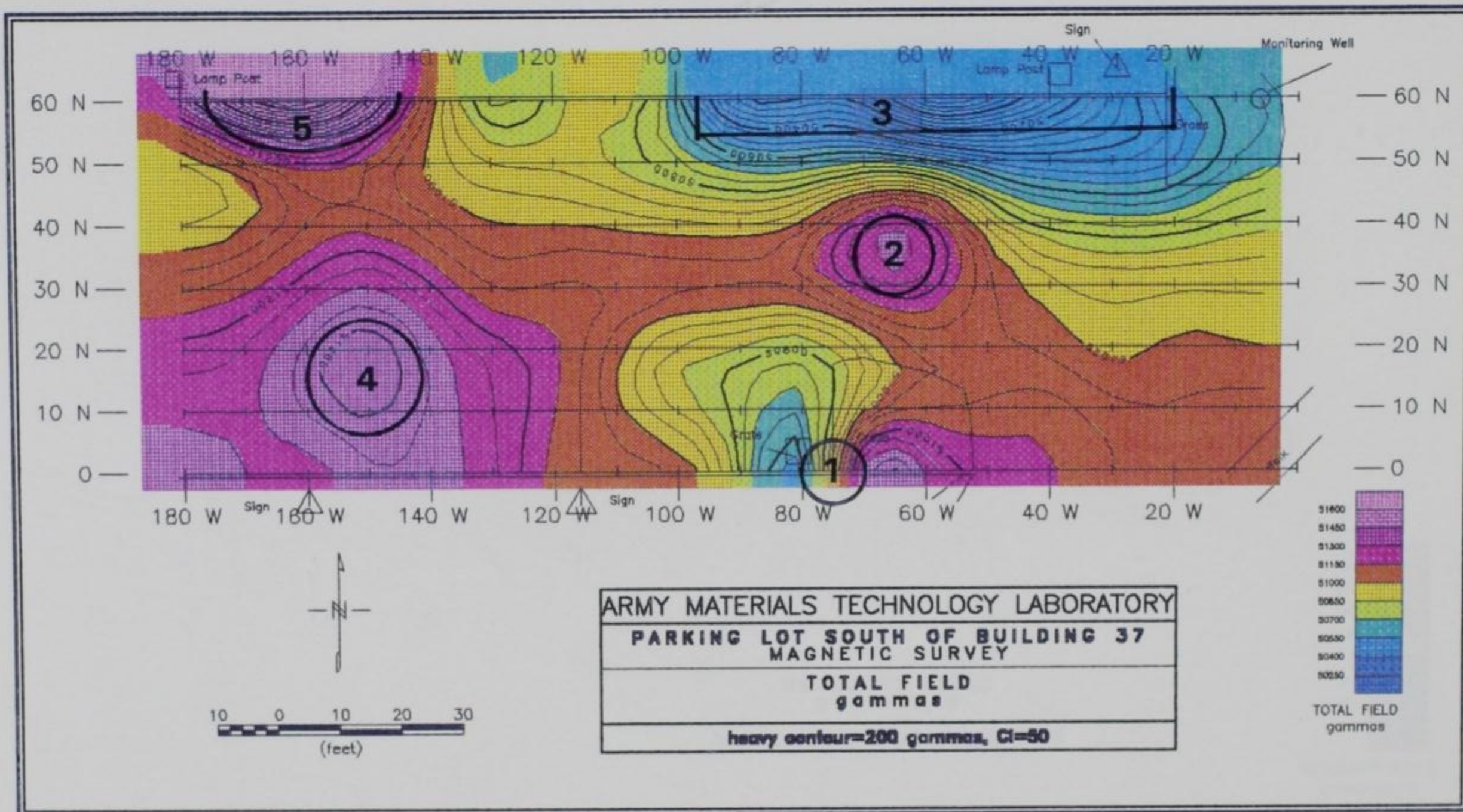

Figure 21. Results of magnetic total field survey, Site 3

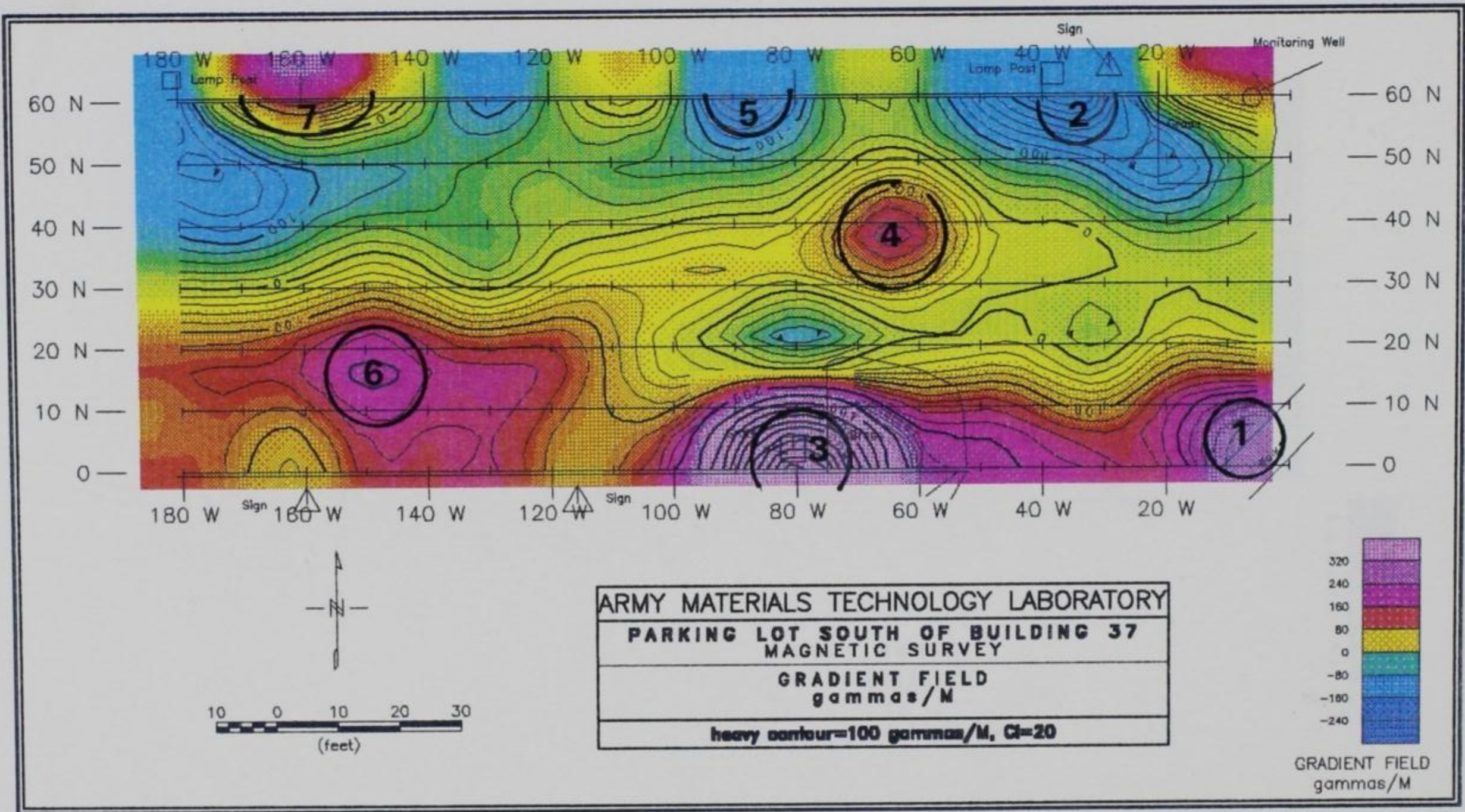

Figure 22. Results of magnetic gradient survey, Site 3

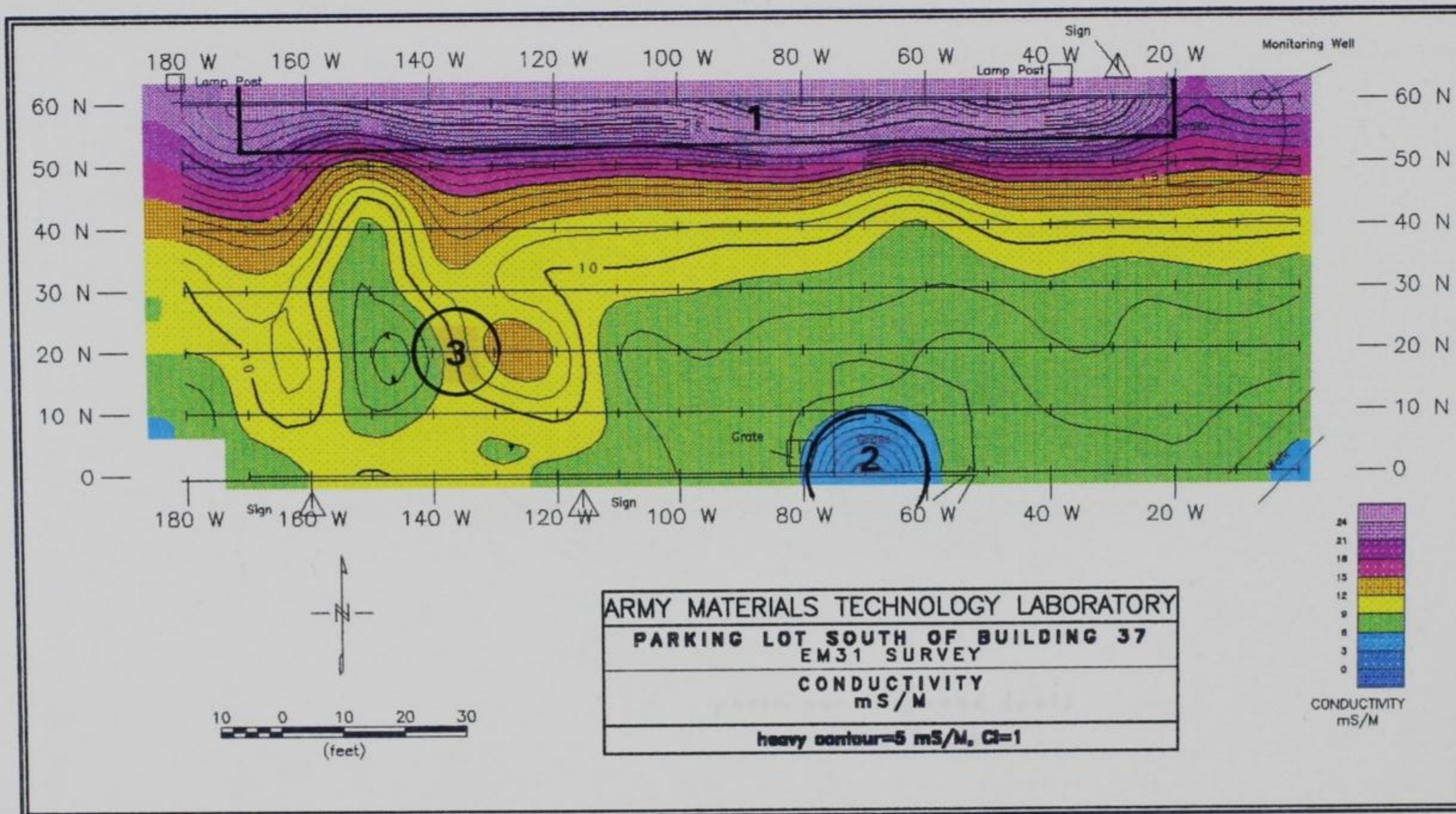

Figure 23. Results of EM-31 conductivity survey, Site 3

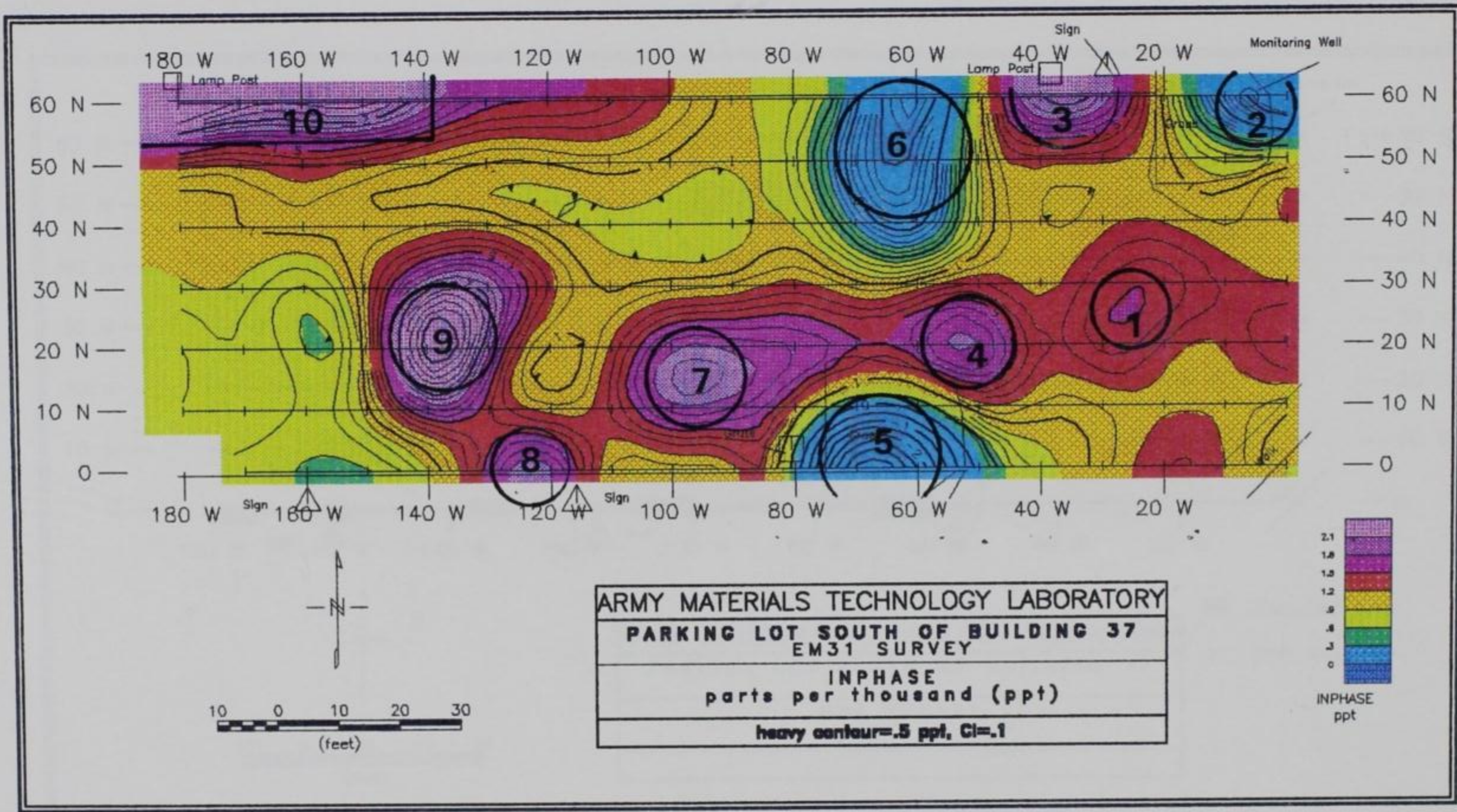

Figure 24. Results of EM-31 in-phase survey, Site 3

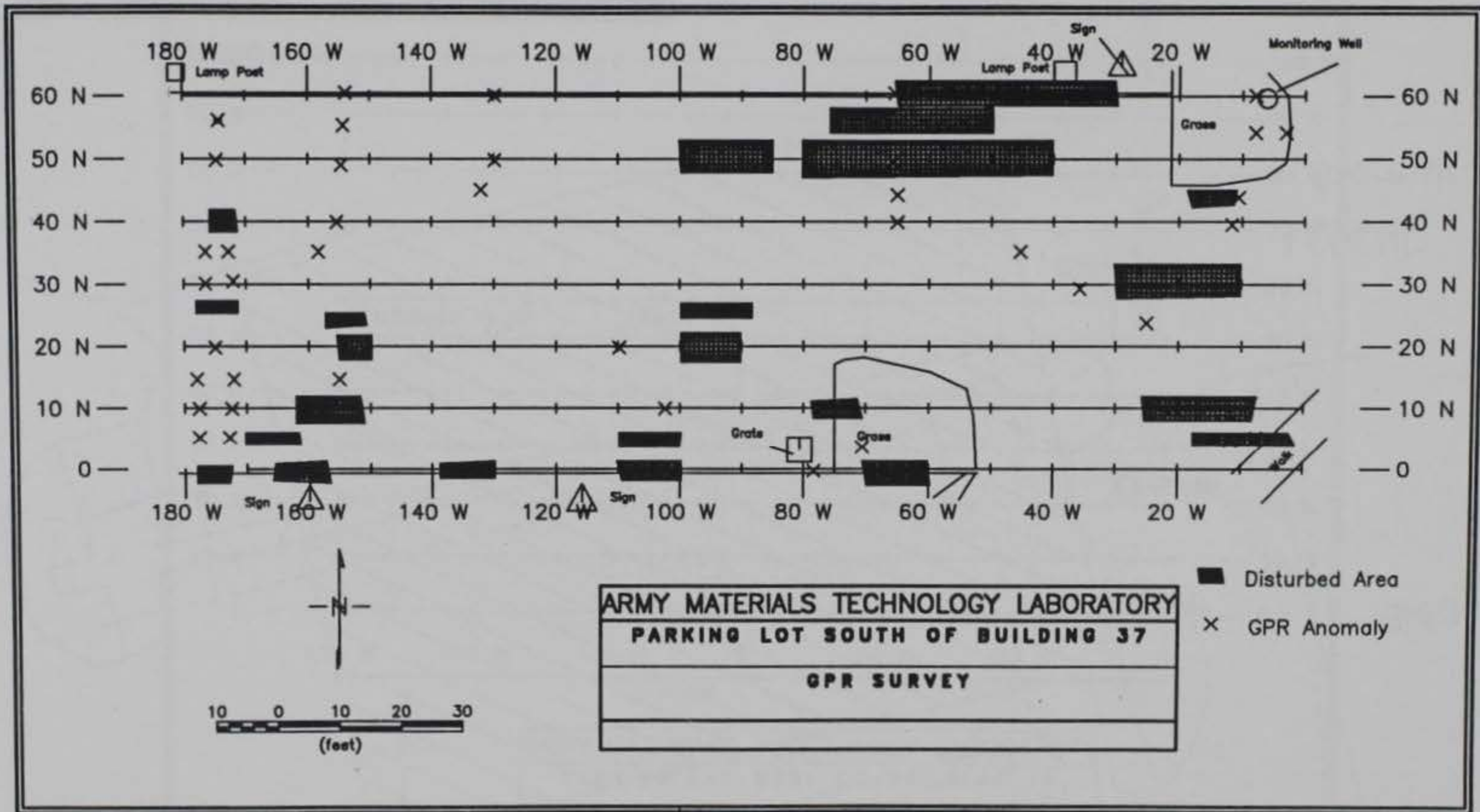

Figure 25. Results of GPR survey, Site 3

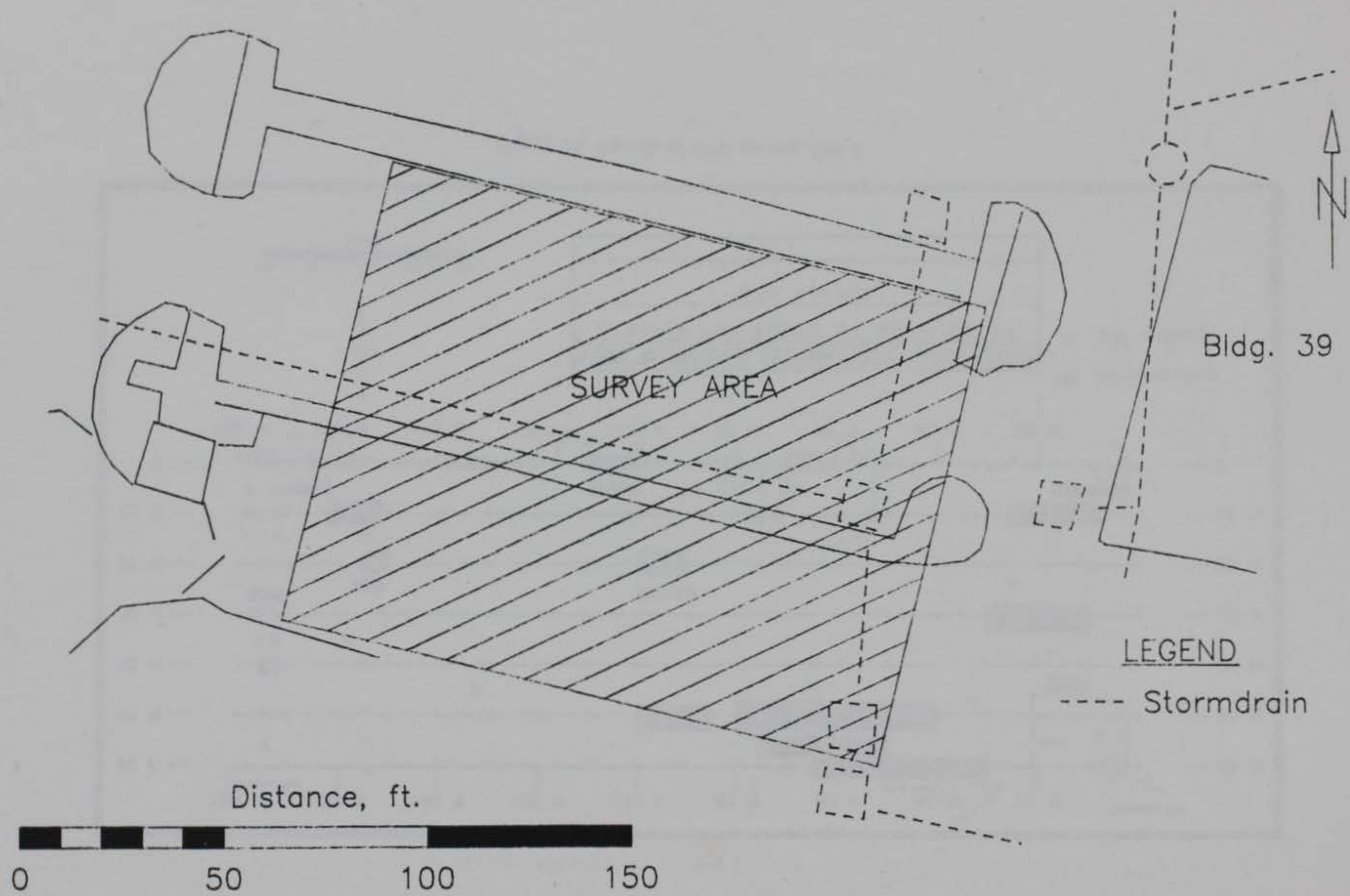

Figure 26. Map of Site 4 showing the area surveyed and location of underground utilities

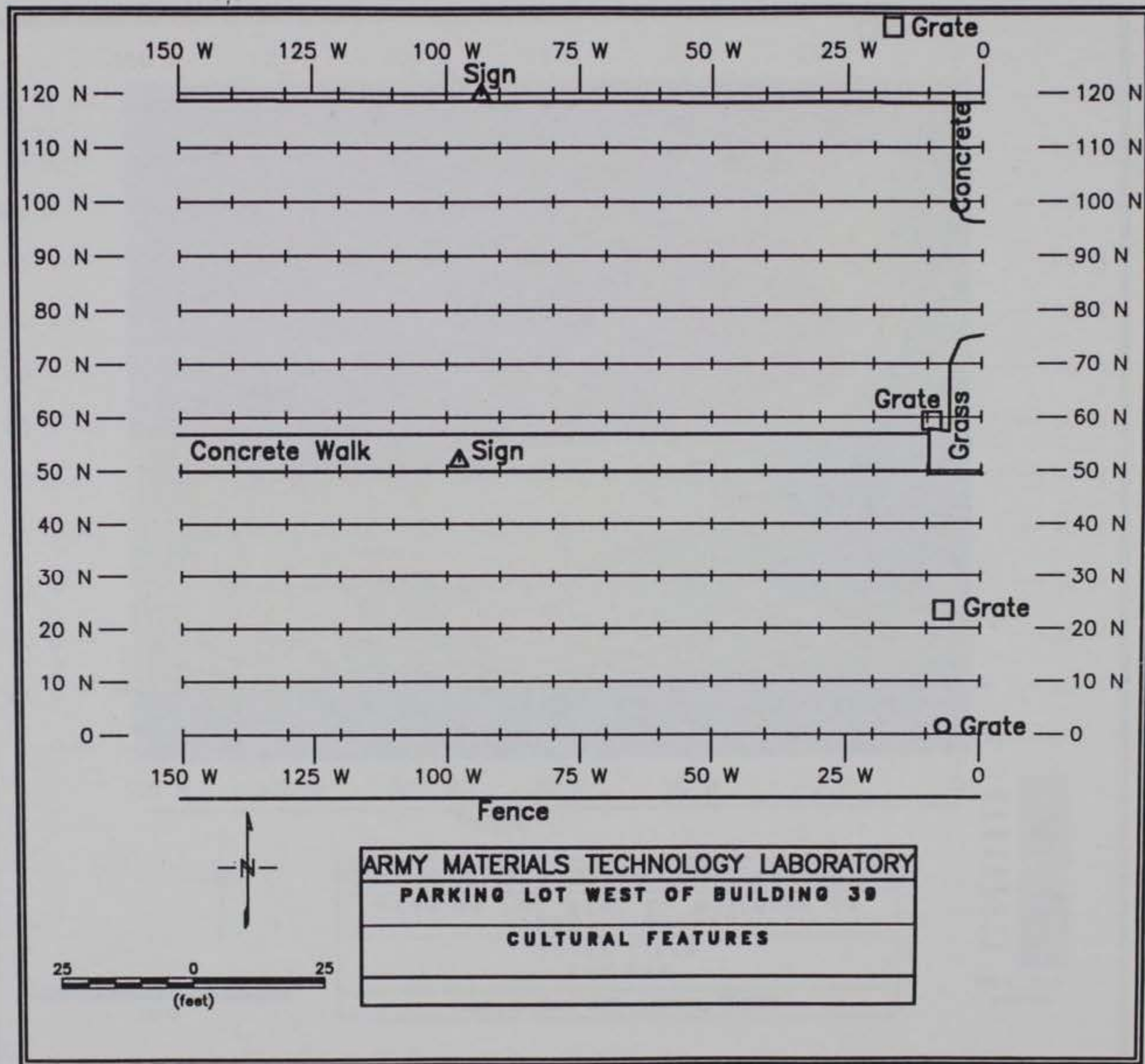

Figure 27. Site 4 survey grid layout and location of cultural features

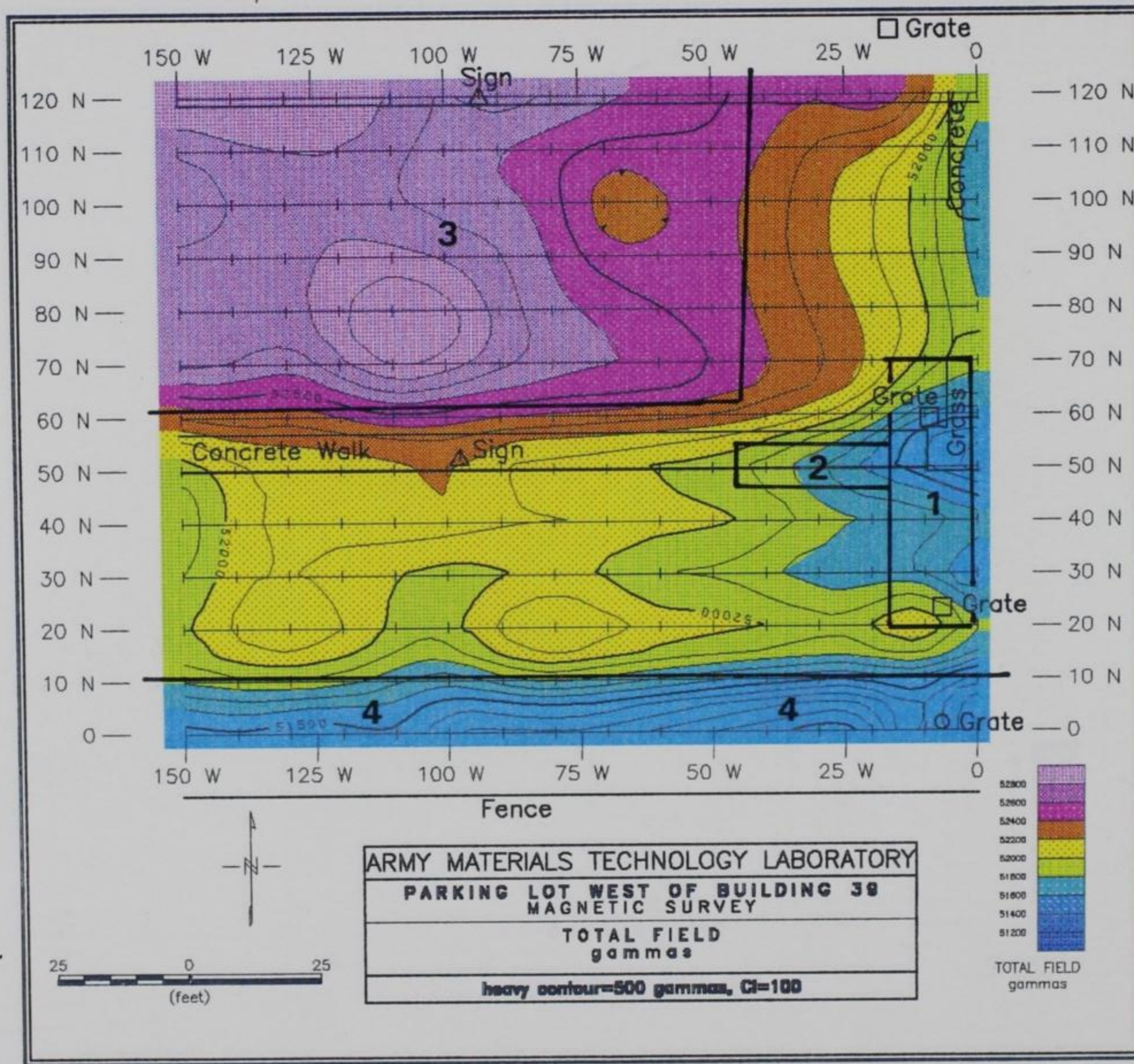

Figure 28. Results of magnetic total field survey, Site 4

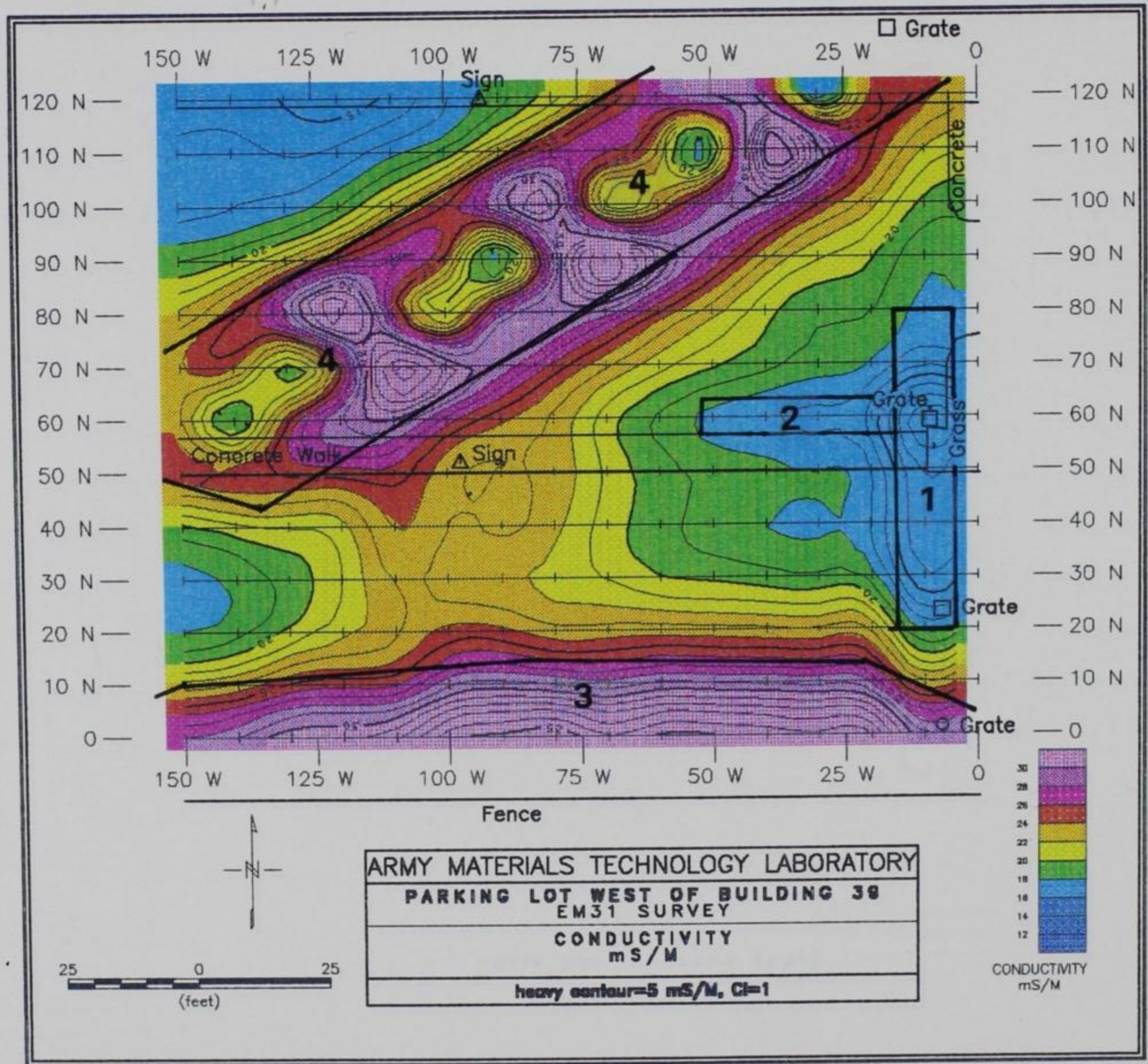

Figure 29. Results of EM-31 conductivity survey, Site 4

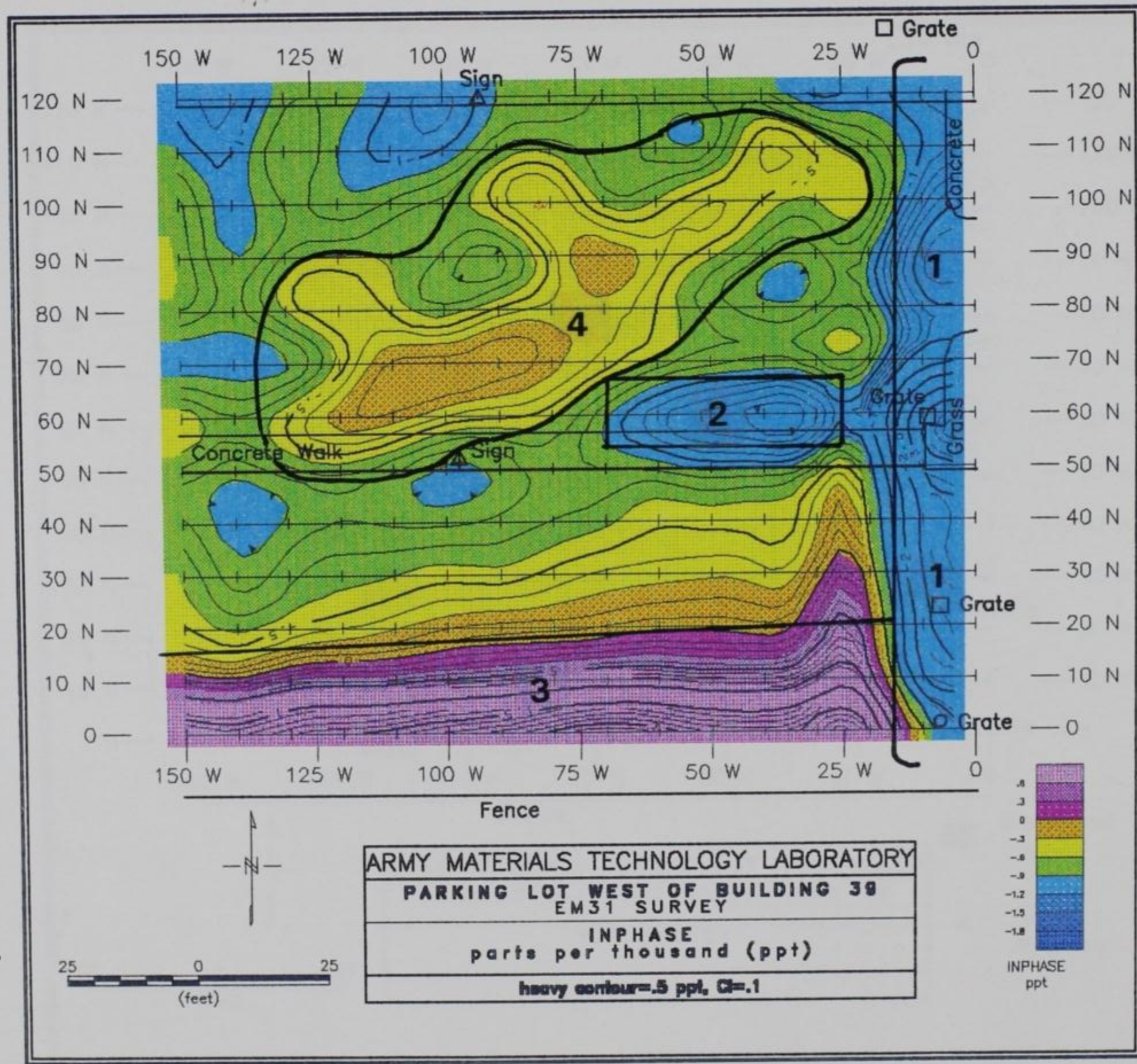

Figure 30. Results of EM-31 in-phase survey, Site 4

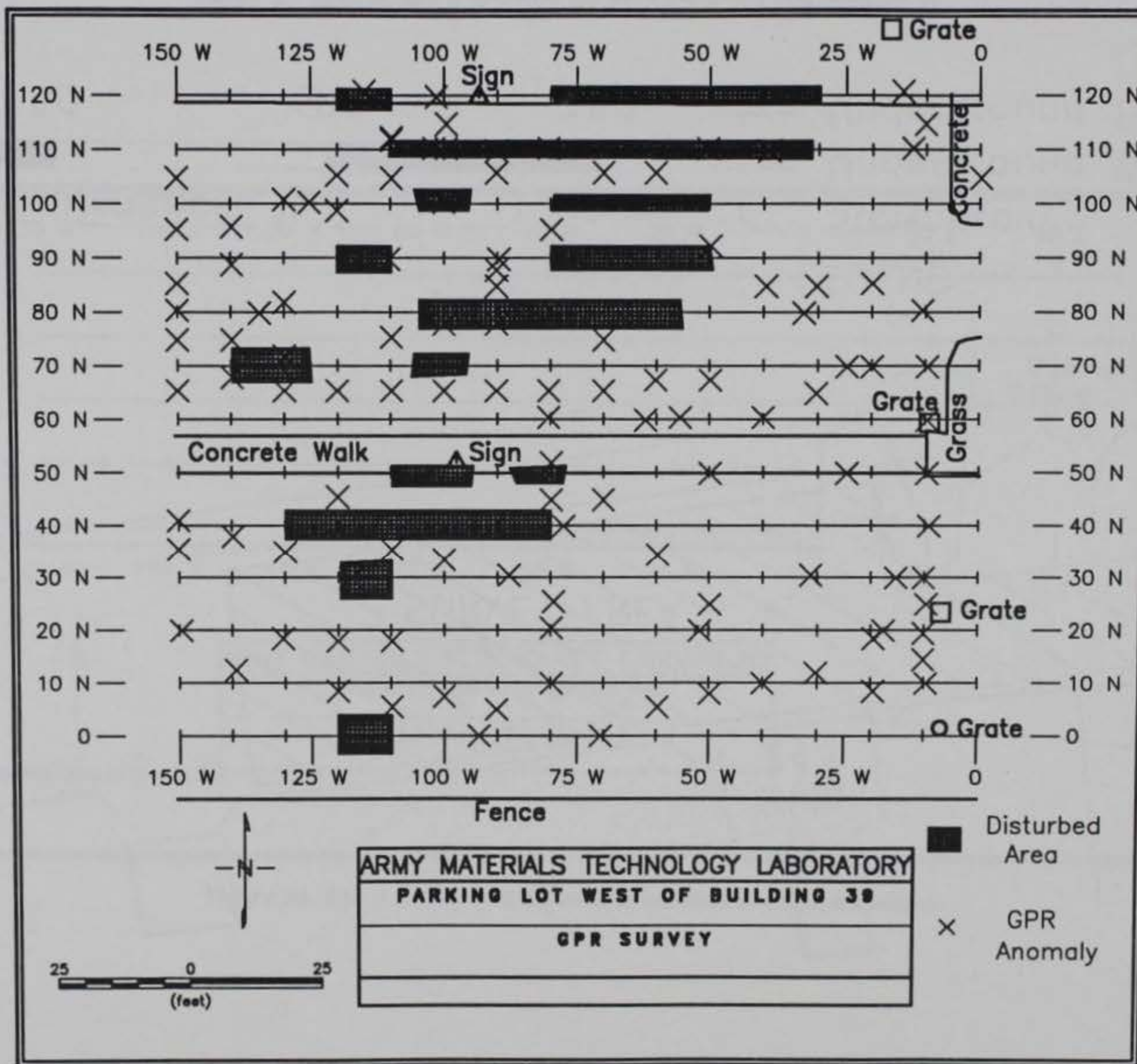

Figure 31. Results of GPR survey, Site 4

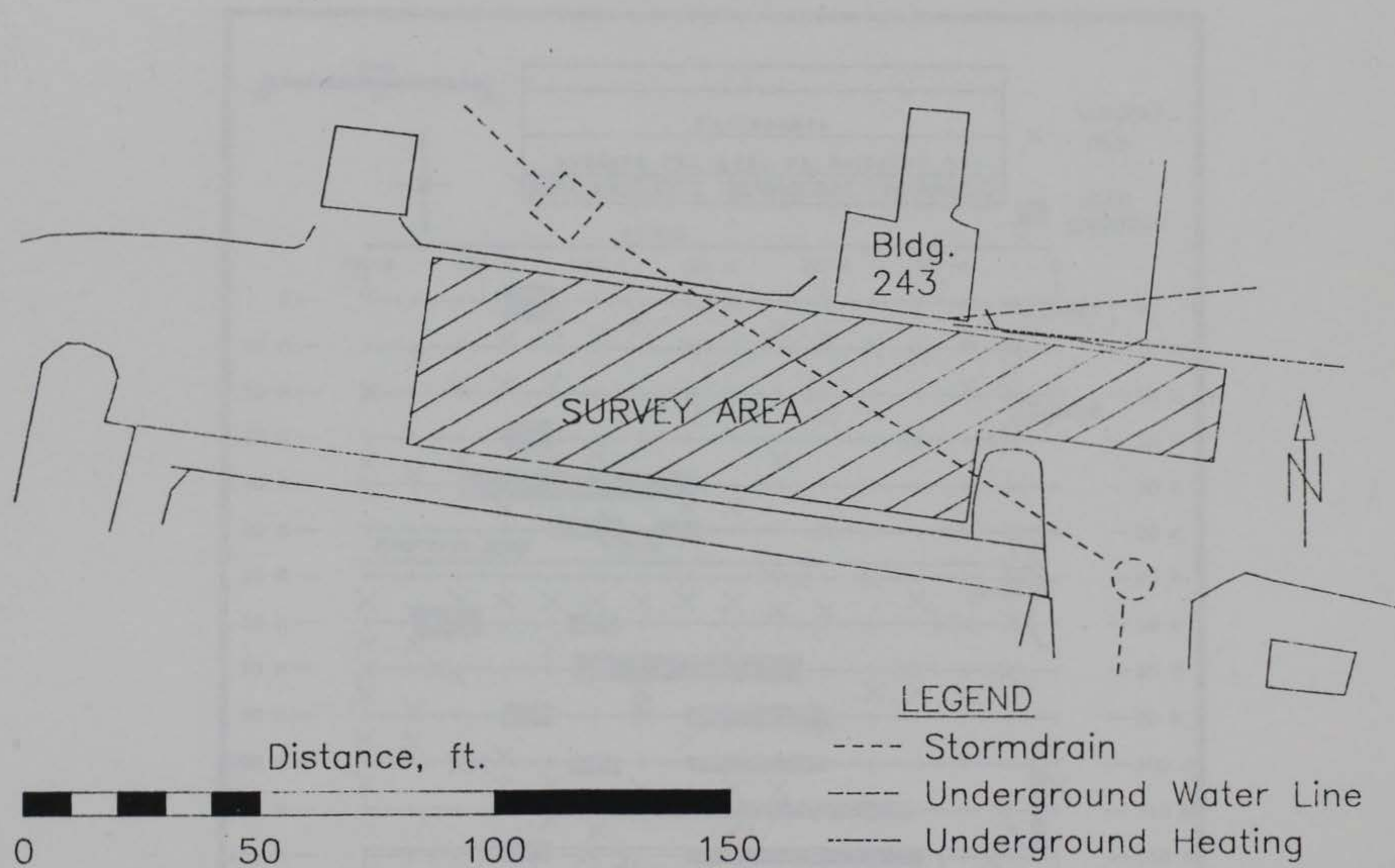

Figure 32. Map of Site 5 showing the area surveyed and location of underground utilities

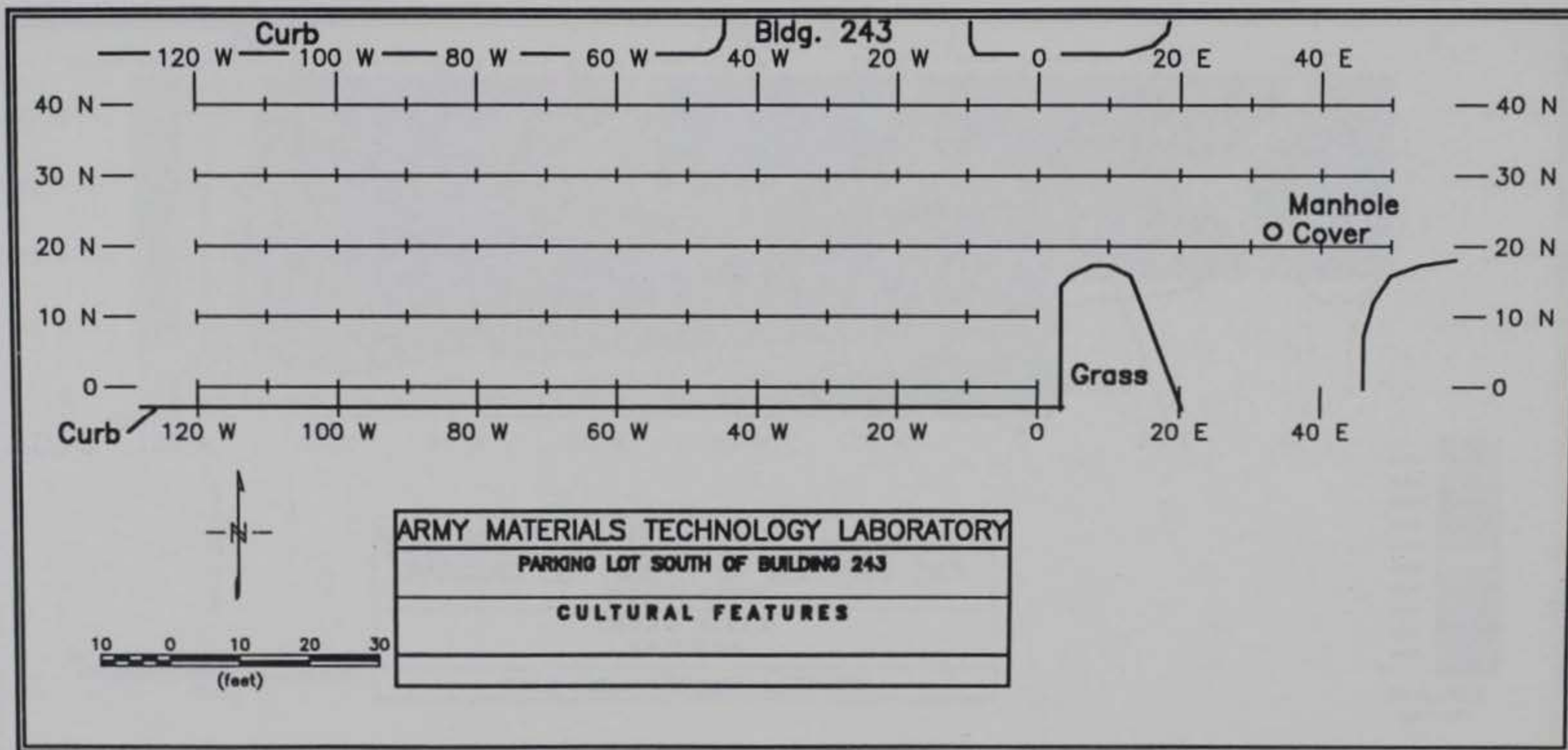

Figure 33. Site 5 survey grid layout and location of cultural features

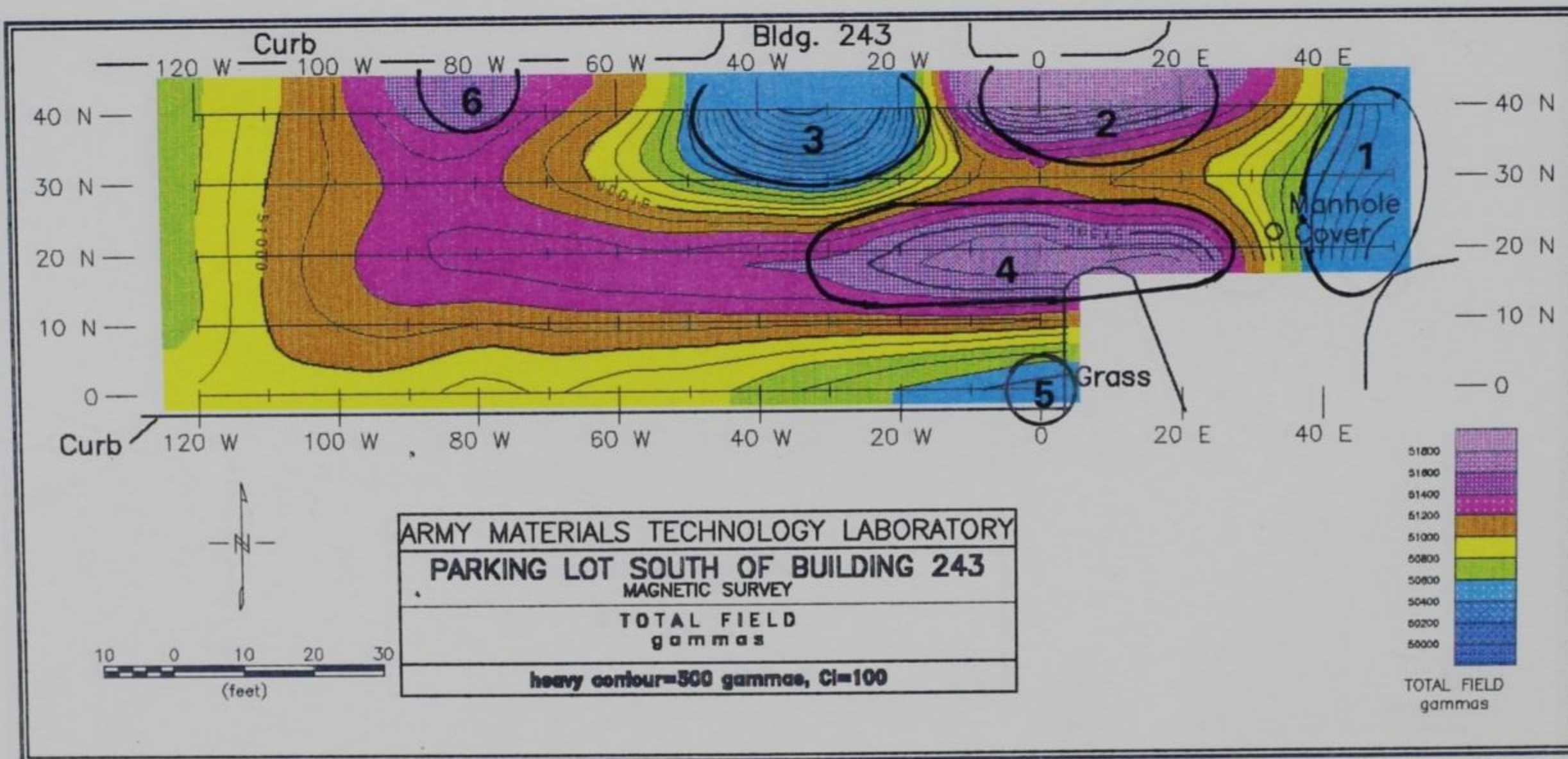

Figure 34. Results of magnetic total field survey, Site 5

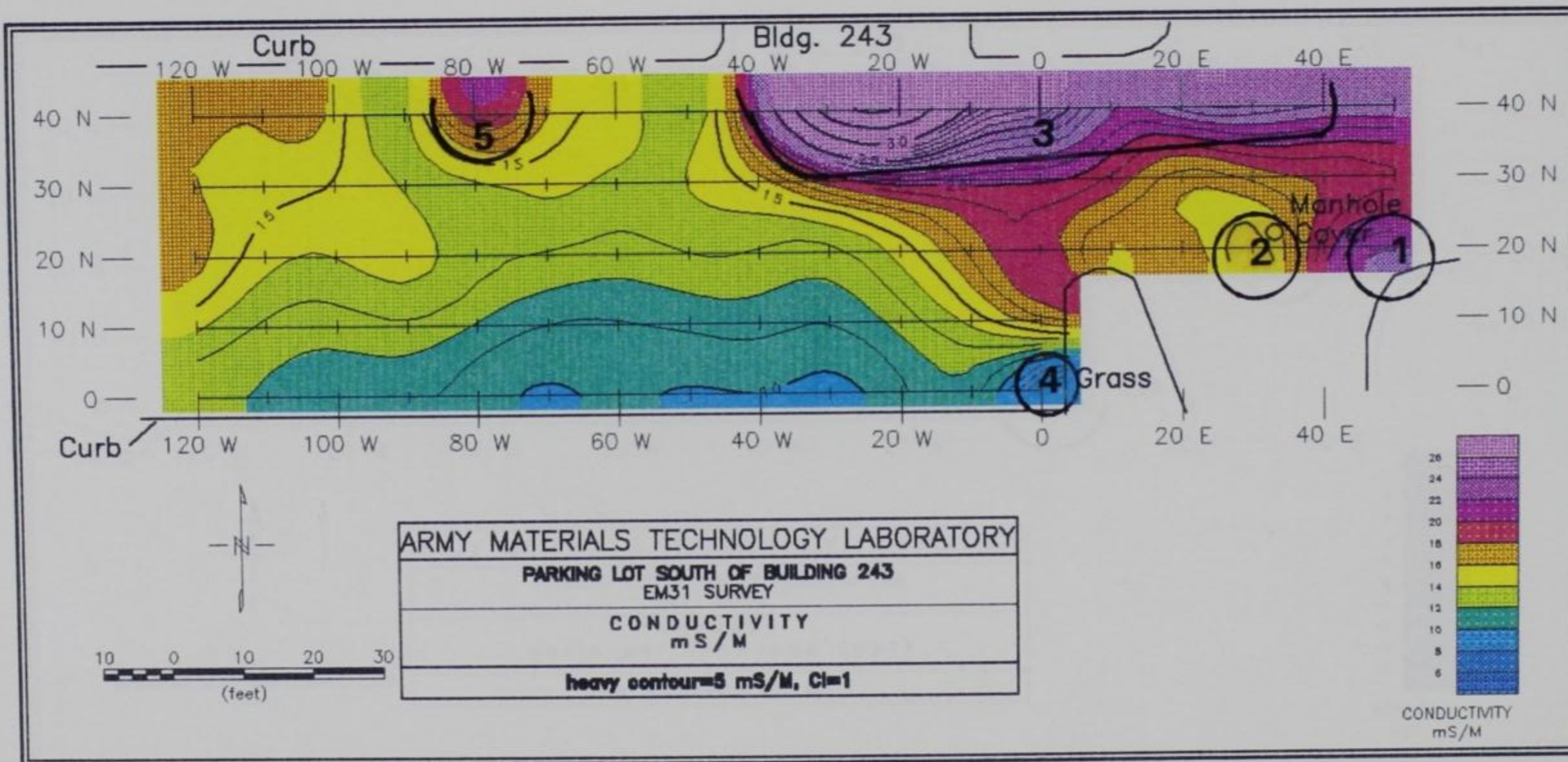

Figure 35. Results of EM-31 conductivity survey, Site 5

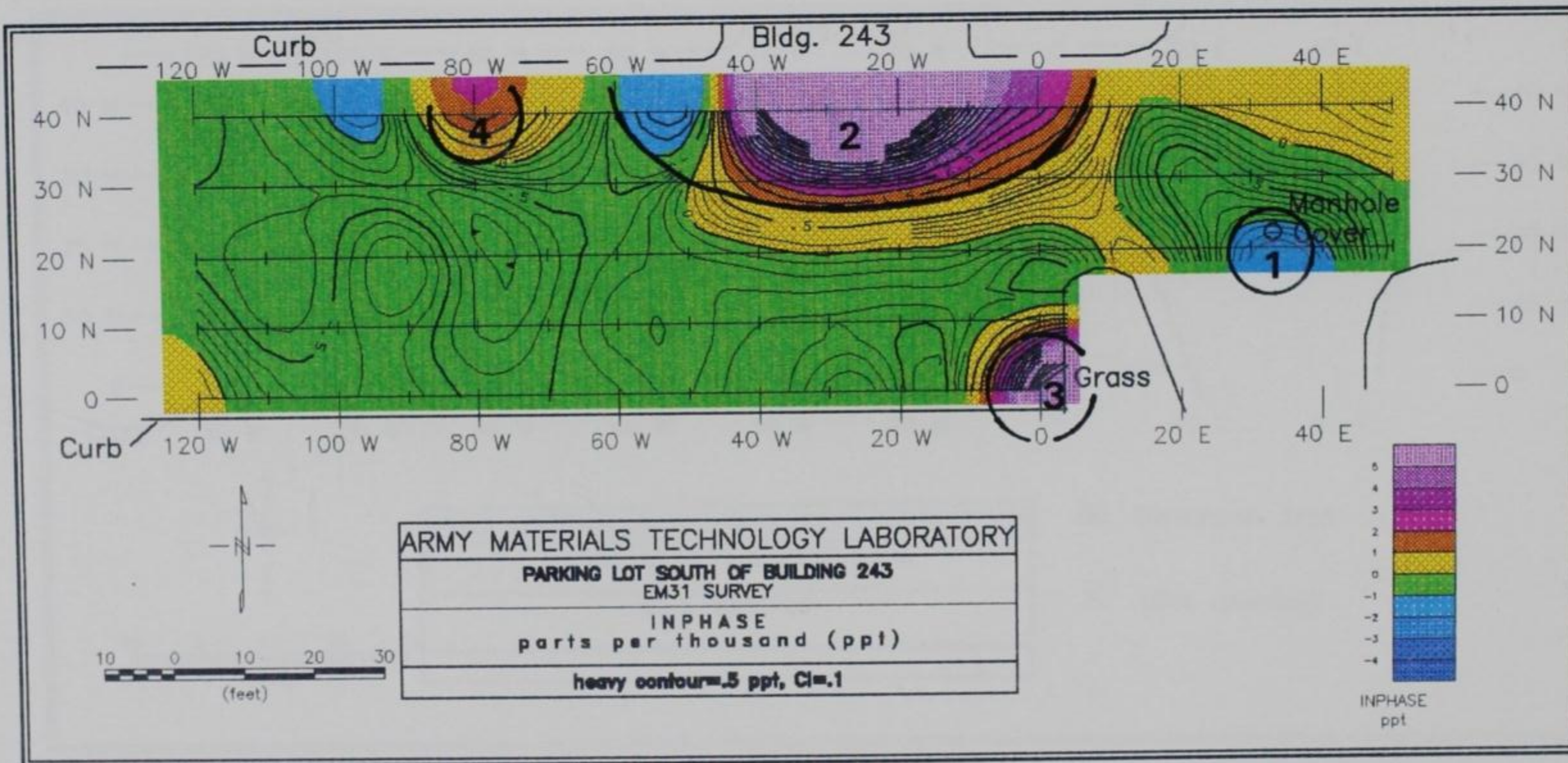

Figure 36. Results of EM-31 in-phase survey, Site 5

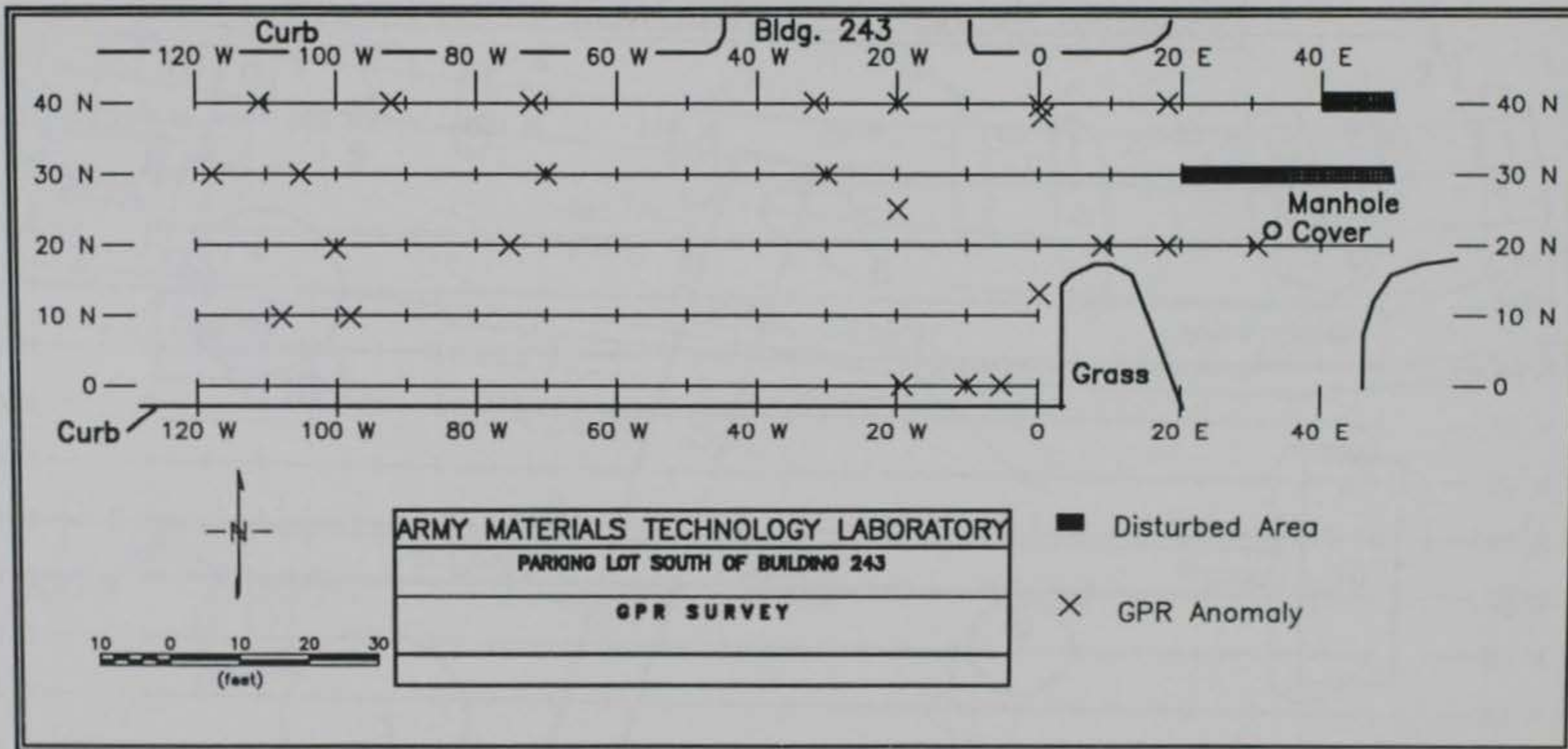

Figure 37. Results of GPR survey, Site 5

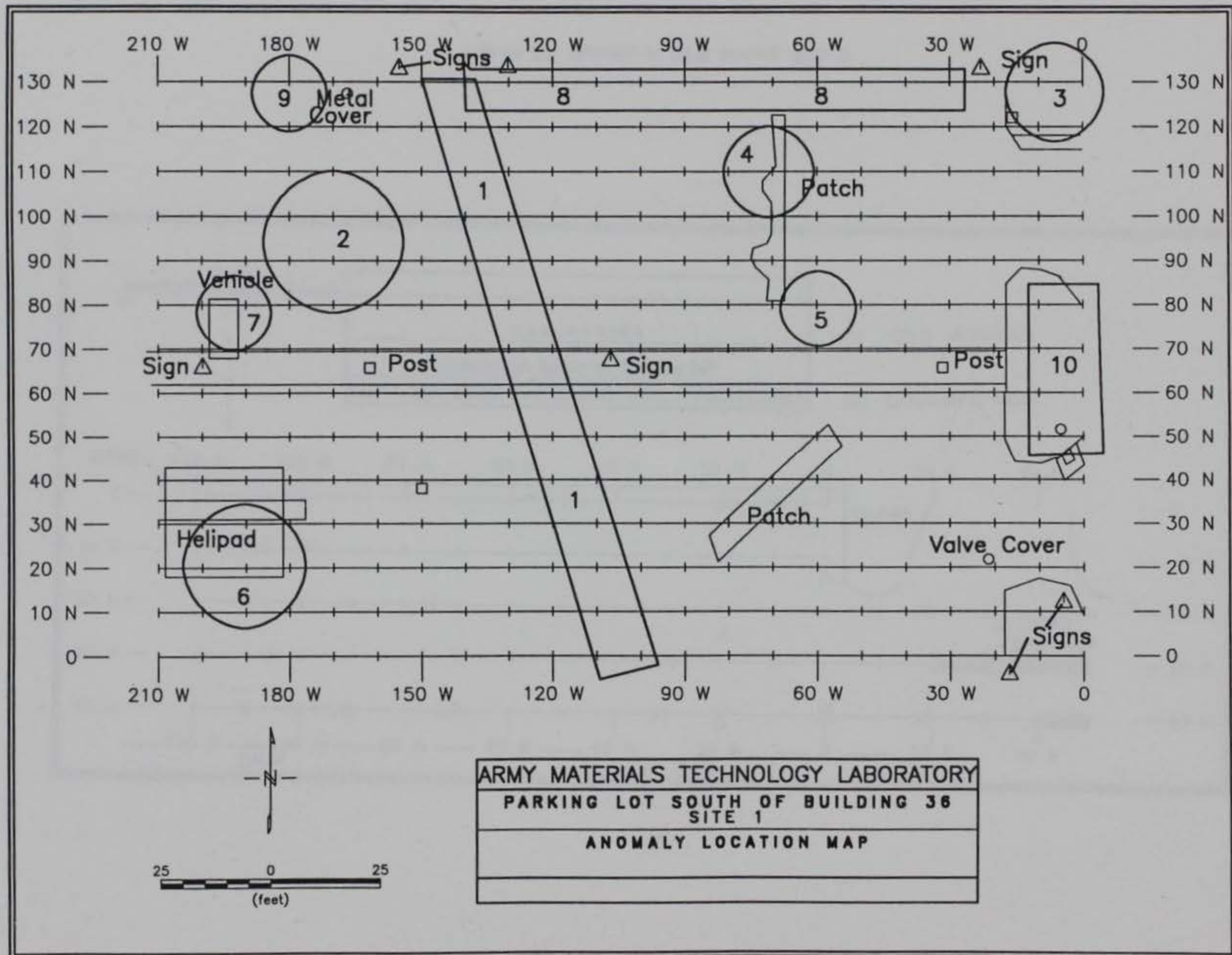
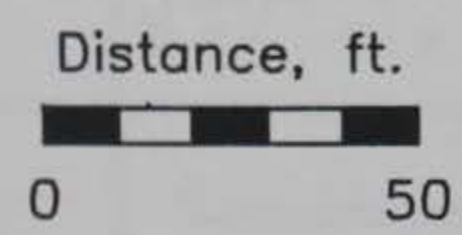
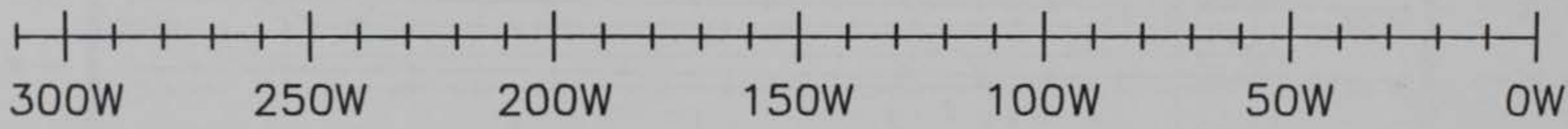
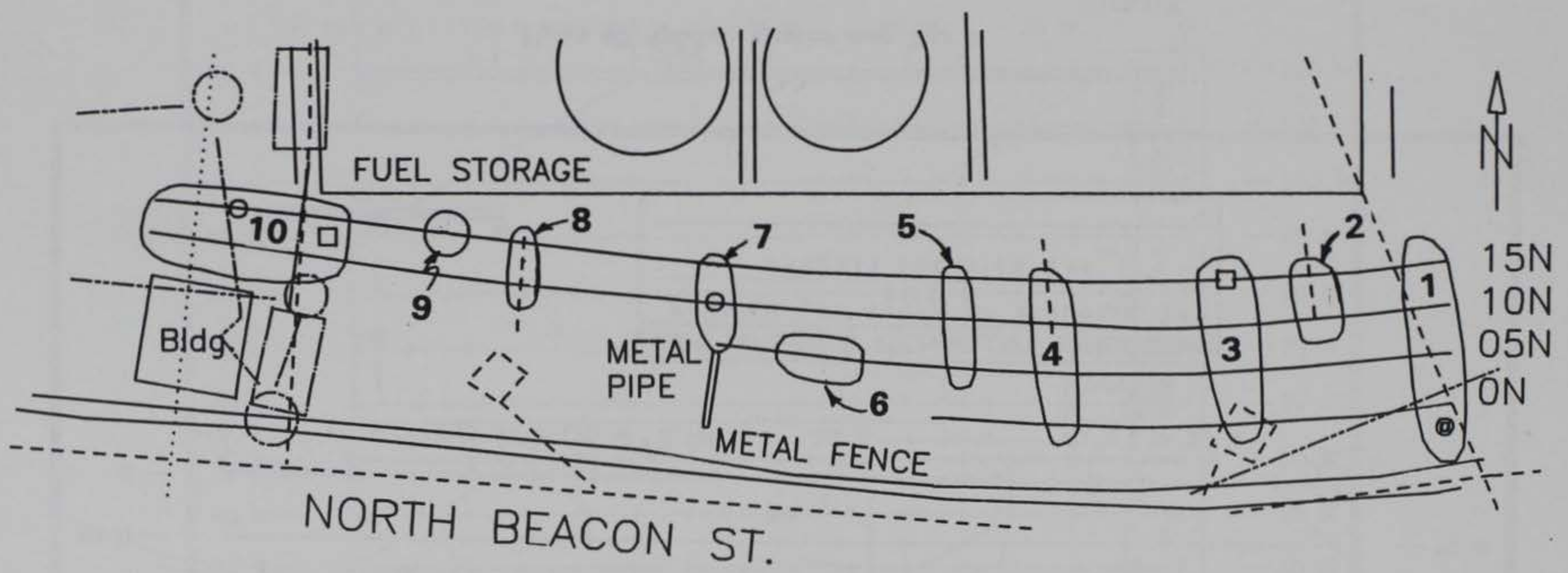

Figure 38. Anomaly location map, Site 1



LEGEND			
⊙	Lamp Post	Underground Water Lines
○	Steel Manhole Cover	-----	Underground Sewer Lines
□	Monitoring Well	-----	Underground Electrical
①	Anomaly Location & No.	-----	Stormdrain

Figure 39. Anomaly location map, Site 2

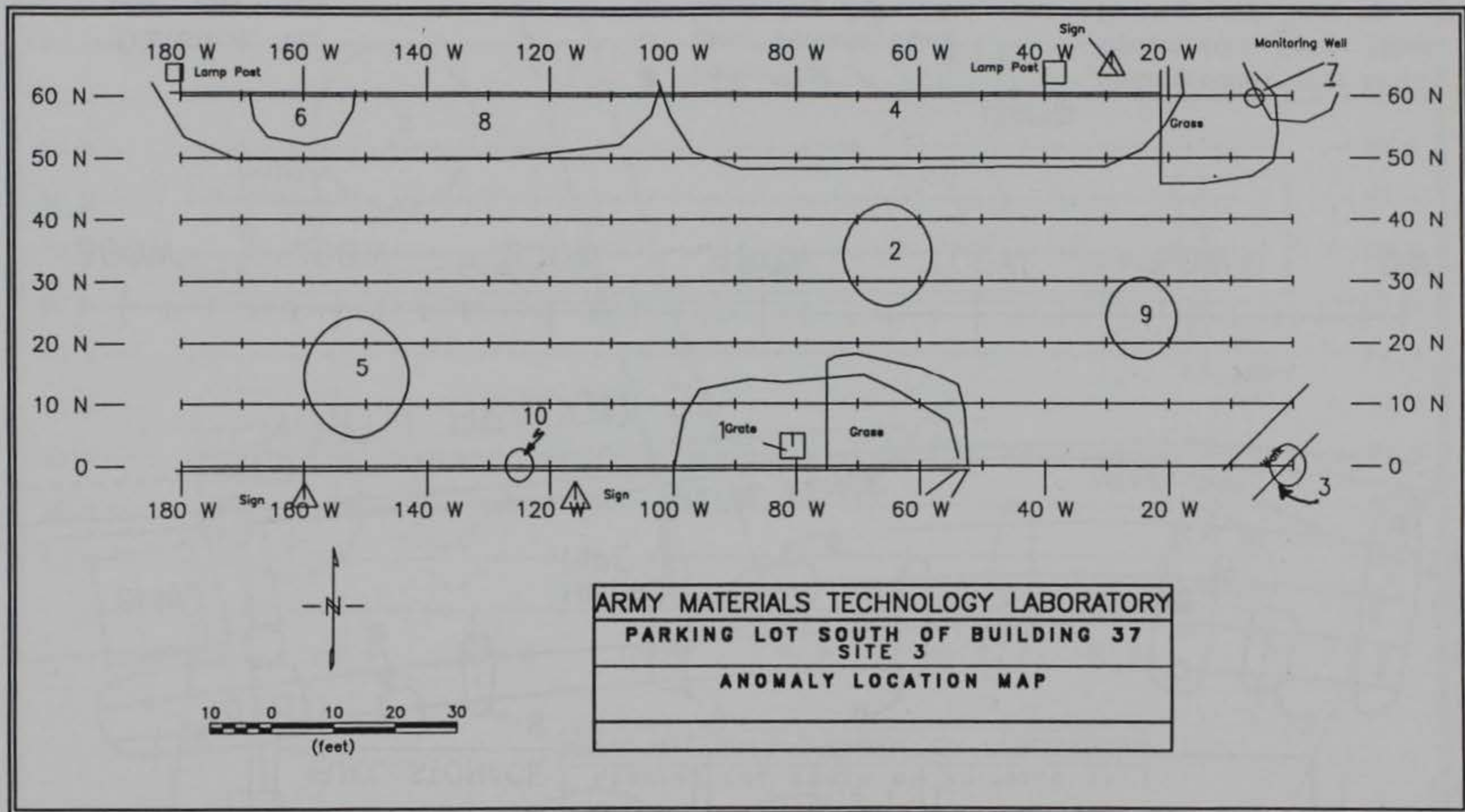

Figure 40. Anomaly location map, Site 3

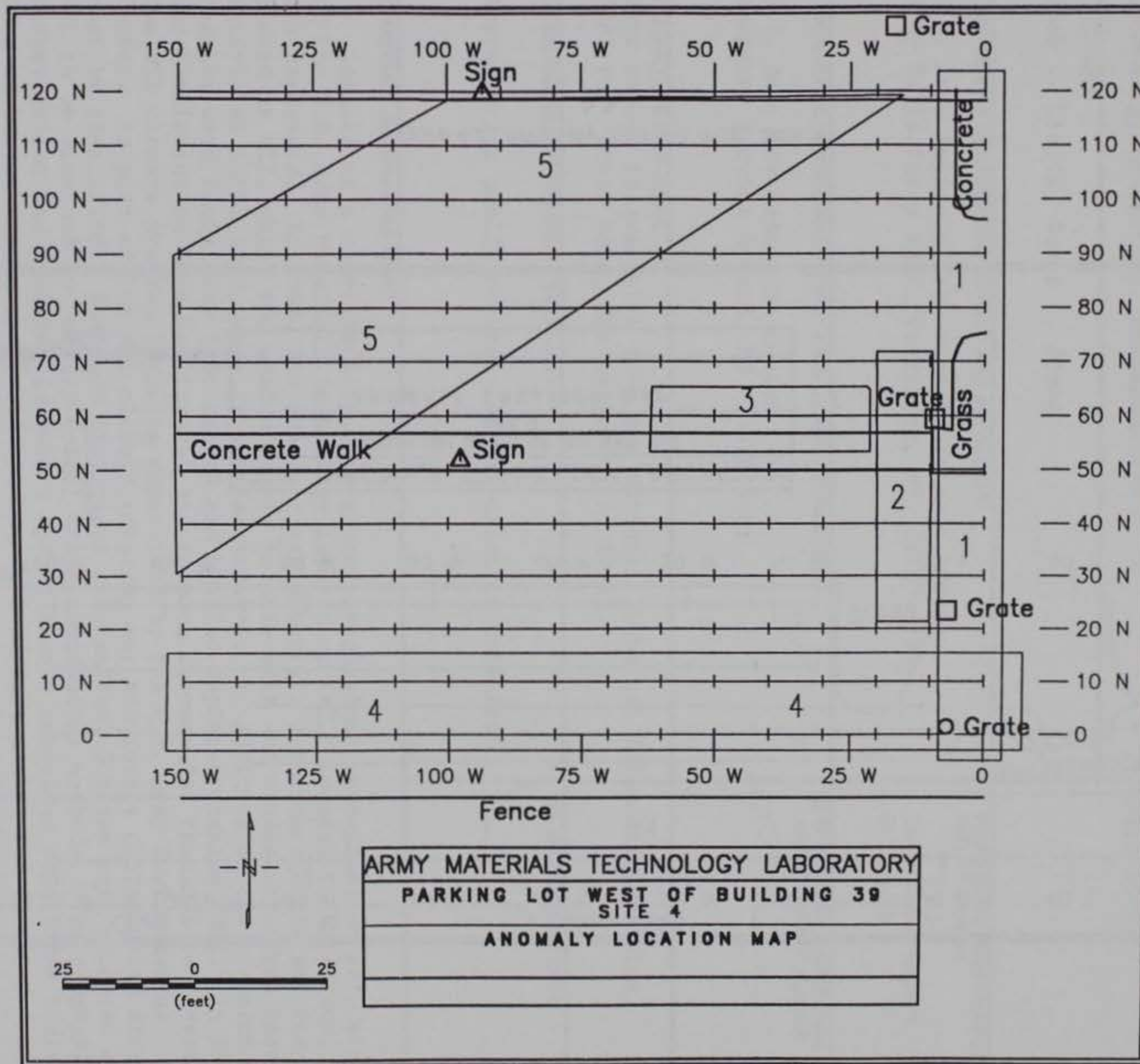

Figure 41. Anomaly location map, Site 4

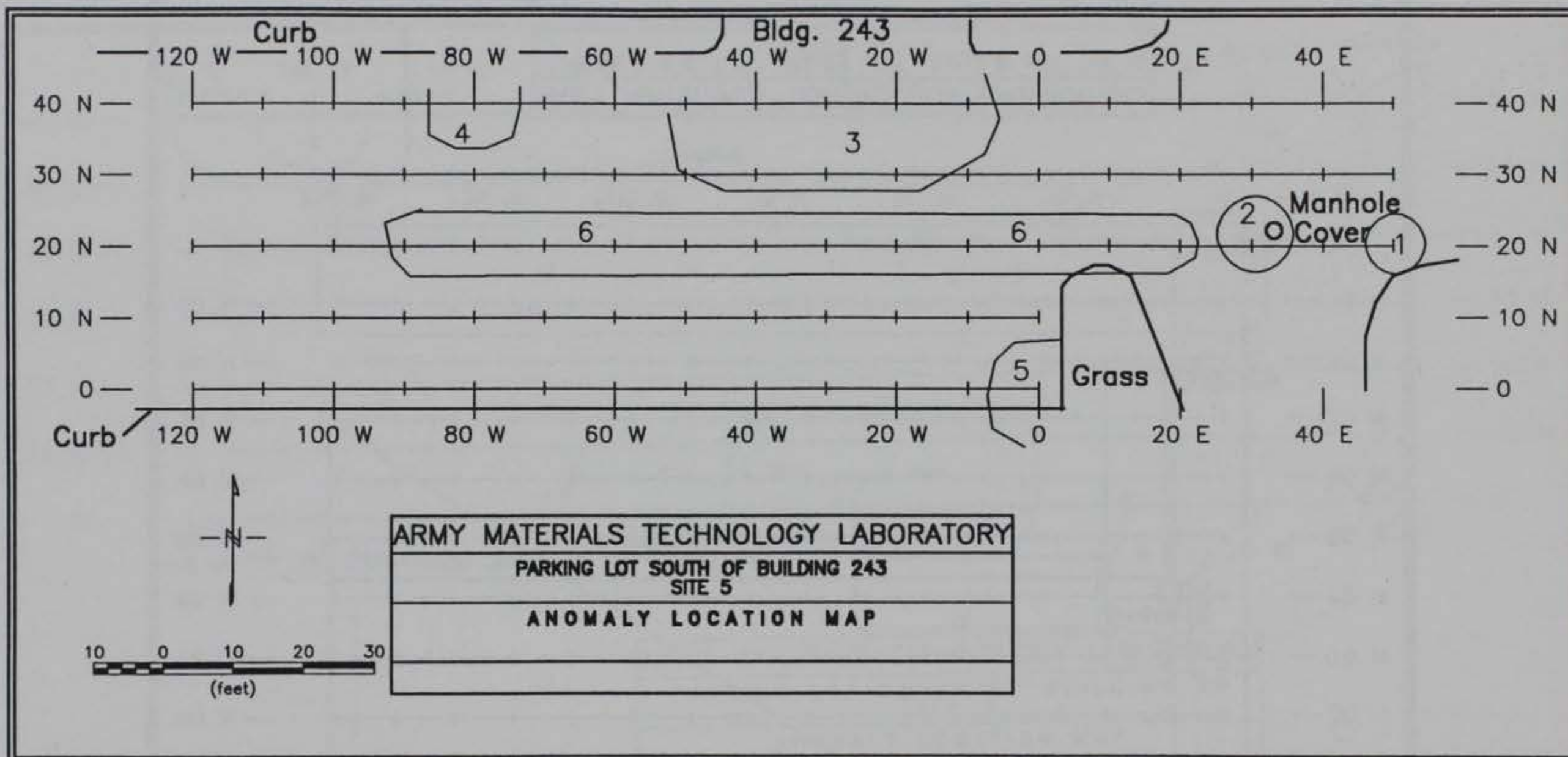

Figure 42. Anomaly location map, Site 5

REPORT DOCUMENTATION PAGE

Form Approved
OMB No. 0704-0188

Public reporting burden for this collection of information is estimated to average 1 hour per response, including the time for reviewing instructions, searching existing data sources, gathering and maintaining the data needed, and completing and reviewing the collection of information. Send comments regarding this burden estimate or any other aspect of this collection of information, including suggestions for reducing this burden, to Washington Headquarters Services, Directorate for Information Operations and Reports, 1215 Jefferson Davis Highway, Suite 1204, Arlington, VA 22202-4302, and to the Office of Management and Budget, Paperwork Reduction Project (0704-0188), Washington, DC 20503.

1. AGENCY USE ONLY (Leave blank)	2. REPORT DATE November 1993	3. REPORT TYPE AND DATES COVERED Final report
---	--	---

4. TITLE AND SUBTITLE Geophysical Investigation at U.S. Army Materials Technology Laboratory, Massachusetts	5. FUNDING NUMBERS MIPR 5432 MIPR 5902
6. AUTHOR(S) José L. Llopis, Janet E. Simms	

7. PERFORMING ORGANIZATION NAME(S) AND ADDRESS(ES) U.S. Army Engineer Waterways Experiment Station 3909 Halls Ferry Road, Vicksburg, MS 39180-6199	8. PERFORMING ORGANIZATION REPORT NUMBER Technical Report GL-93-29
---	---

9. SPONSORING/MONITORING AGENCY NAME(S) AND ADDRESS(ES) U.S. Army Environmental Center Aberdeen Proving Ground, MD 21010-5401	10. SPONSORING/MONITORING AGENCY REPORT NUMBER
--	---

11. SUPPLEMENTARY NOTES
This report is available from the National Technical Information Service, 5285 Port Royal Road, Springfield, VA 22161.

12a. DISTRIBUTION/AVAILABILITY STATEMENT Approved for public release; distribution is unlimited	12b. DISTRIBUTION CODE
---	-------------------------------

13. ABSTRACT (Maximum 200 words)

Results of a comprehensive, integrated geophysical investigation at 5 sites at the U.S. Army Materials Technology Laboratory (MTL) located in Watertown, MA, are presented. In 1960, the Army's first materials research reactor was completed at MTL, which was used actively in molecular and atomic structure research activities until 1970, when it was deactivated. In addition to the research reactor were facilities that stored and handled depleted uranium (DU). In 1989, the Commission on Base Realignment and Closure recommended that MTL be closed. The MTL closure program is being supervised by the U.S. Army Environmental Center. As part of the MTL closure program, any previously contaminated sites must be identified. Based on historical information, 5 sites were selected at MTL to be examined in further detail using geophysical methods. The geophysical investigation was designed to detect and delineate anomalous conditions indicative of buried waste, waste containers, fuel storage tanks, and unmapped drain or sewer lines having the potential of carrying wastes off the site.

(Continued)

14. SUBJECT TERMS Electromagnetics Geophysics Magnetics Geophysical surveys Ground penetrating radar	15. NUMBER OF PAGES 75
	16. PRICE CODE

17. SECURITY CLASSIFICATION OF REPORT UNCLASSIFIED	18. SECURITY CLASSIFICATION OF THIS PAGE UNCLASSIFIED	19. SECURITY CLASSIFICATION OF ABSTRACT	20. LIMITATION OF ABSTRACT
--	---	--	-----------------------------------

13. ABSTRACT (Continued).

The geophysical program included electromagnetic (EM), magnetic, and ground penetrating radar (GPR) methods. Anomalous conditions were found at each of the investigated sites. The results of each geophysical method were integrated to produce an anomaly map of each site. An interpretation as to the cause and a recommendation for or against any further remedial action for each mapped anomaly was rendered.