

# Special Report 81-14

June 1981

## LOSSES FROM THE FORT WAINWRIGHT HEAT DISTRIBUTION SYSTEM

G.L. Phetteplace, W. Willey and M.A. Novick

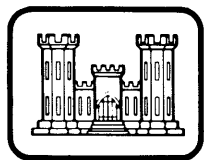

UNITED STATES ARMY CORPS OF ENGINEERS  
COLD REGIONS RESEARCH AND ENGINEERING LABORATORY  
HANOVER, NEW HAMPSHIRE, U.S.A.



REPORT DOCUMENTATION PAGE		READ INSTRUCTIONS BEFORE COMPLETING FORM
1. REPORT NUMBER Special Report 81-14	2. GOVT ACCESSION NO.	3. RECIPIENT'S CATALOG NUMBER
4. TITLE (and Subtitle) LOSSES FROM THE FORT WAINWRIGHT HEAT DISTRIBUTION SYSTEM	5. TYPE OF REPORT & PERIOD COVERED	
	6. PERFORMING ORG. REPORT NUMBER	
7. AUTHOR(s) G.L. Phetteplace, W. Willey and M.A. Novick	8. CONTRACT OR GRANT NUMBER(s)	
9. PERFORMING ORGANIZATION NAME AND ADDRESS U.S. Army Cold Regions Research and Engineering Laboratory Hanover, New Hampshire 03755	10. PROGRAM ELEMENT, PROJECT, TASK AREA & WORK UNIT NUMBERS DA Project 4A161101A91D Work Unit 294	
11. CONTROLLING OFFICE NAME AND ADDRESS U.S. Army Cold Regions Research and Engineering Laboratory Hanover, New Hampshire 03755	12. REPORT DATE June 1981	
	13. NUMBER OF PAGES 33	
14. MONITORING AGENCY NAME & ADDRESS (if different from Controlling Office)	15. SECURITY CLASS. (of this report) Unclassified	
	15a. DECLASSIFICATION/DOWNGRADING SCHEDULE	
16. DISTRIBUTION STATEMENT (of this Report)  Approved for public release; distribution unlimited.		
17. DISTRIBUTION STATEMENT (of the abstract entered in Block 20, if different from Report)		
18. SUPPLEMENTARY NOTES		
19. KEY WORDS (Continue on reverse side if necessary and identify by block number) Electric generators Heat loss Heating plants Steam pipes		
20. ABSTRACT (Continue on reverse side if necessary and identify by block number) This report estimates the heat losses from the heat distribution system at Fort Wainwright, Alaska. Specific data on the Fort Wainwright heat and power plant are given and a method is then developed to calculate the heat losses from buried utilidor systems, such as the one at Fort Wainwright. This method is programmed for computer execution and estimates are made for the Fort Wainwright system, where heat losses are found to be $2.045 \times 10^5$ MBtu/yr. Possible improvements to the system to reduce heat losses are examined. Of the possible combinations of additional pipe insulation investigated, the addition of 1 in. of insulation to the steam pipe only is the most economically favorable. The results also indicate that insulating only the generally larger pipes found in larger utilidors would be the most economically favorable approach. Possible reductions in heat losses due to reduced steam temperature are also given, as well as recommendations for refinement of the predictions.		

## PREFACE

This report was prepared by G.E. Phetteplace, Mechanical Engineer, W. Willey, Engineering Aid, and M.A. Novick, Engineering Aid, of the Applied Research Branch, Experimental Engineering Division, U.S. Army Cold Regions Research and Engineering Laboratory. The work was supported by DA Project 4A161101A91D, *In-House Laboratory Independent Research*, Work Unit 294, *Energy Storage and Transmission Systems of Facilities in Cold Regions*.

The authors would like to thank Mary Remley Albert and Dr. Virgil Lunardini for their help and suggestions during the data collection and reduction. The authors would also like to thank Stephen Flanders and F. Donald Haynes for their careful technical review of the report and many worthwhile suggestions.

## CONTENTS

	Page
Abstract .....	i
Preface .....	ii
Nomenclature.....	iv
Introduction .....	1
The Fort Wainwright heat and power plant.....	1
Heat distribution at Fort Wainwright .....	5
Heat losses from utilidor systems .....	6
System efficiency and possible improvements.....	10
Conclusions and recommendations .....	13
Literature cited .....	14
Appendix A : Heat distribution system data .....	
Appendix B : Utilidor heat loss program.....	
Appendix C : Sample input and output data files.....	

## ILLUSTRATIONS

Figure	
1. The ground above a buried utilidor in March at Fort Wainwright .....	2
2. Fort Wainwright heat and power plant .....	4
3. Overall combined plant efficiency and normalized electric output for the Fort Wainwright power plant .....	5
4. Steam flow and degree-day data for the Fort Wainwright power plant.....	5
5. Computer program flow chart .....	9
6. Ground surface temperature and heat losses for an average year.....	10
7. Normalized heat export and heat loss for 1978.....	11
8. System heat losses as a function of steam temperature.....	13

## TABLES

Table	
1. Heat balances for typical electrical and combined heat and power plants.....	2
2. Exported heat and calculated heat losses for calendar year 1978 .....	11
3. The effect of increasing insulation thickness on all pipes .....	12
4. The effect of increasing insulation thickness on pipes in utilidors 3½ ft by 3½ ft or larger .....	12

## NOMENCLATURE

$D_c$	outside diameter of the condensate pipe (ft)	$T_{ei}$	effective insulation surface temperature ( $^{\circ}\text{F}$ )
$D_{eu}$	effective utilidor inside diameter (ft)	$T_g$	ground temperature ( $^{\circ}\text{F}$ )
$D_s$	outside diameter of the steam pipe (ft)	$T_{mi}$	average temperature of pipe insulation ( $^{\circ}\text{F}$ )
$g$	gravitational constant ( $\text{ft}/\text{s}^2$ )	$T_s$	steam temperature ( $^{\circ}\text{F}$ )
$k_a$	thermal conductivity of air ( $\text{Btu}/\text{hr ft } ^{\circ}\text{F}$ )	$T_{si}$	steam pipe insulation outer surface temperature ( $^{\circ}\text{F}$ )
$k_{ca}$	effective thermal conductivity of the air ( $\text{Btu}/\text{hr ft } ^{\circ}\text{F}$ )	$T_{ui}$	inner utilidor wall temperature ( $^{\circ}\text{F}$ )
$k_i$	insulation thermal conductivity ( $\text{Btu}/\text{hr ft } ^{\circ}\text{F}$ )	$T_{uo}$	outer utilidor wall temperature ( $^{\circ}\text{F}$ )
$k_s$	thermal conductivity of the soil ( $\text{Btu}/\text{hr ft } ^{\circ}\text{F}$ )	$U_o$	overall $U$ value of subsystem ( $\text{Btu}/\text{hr ft } ^{\circ}\text{F}$ )
$k_u$	thermal conductivity of the utilidor material ( $\text{Btu}/\text{hr ft } ^{\circ}\text{F}$ )	$x_B$	utilidor burial depth (ft)
$L$	subsystem length (ft)	$x_{ci}$	insulation thickness on condensate pipe (ft)
$N_G$	Grashof number (dimensionless)	$x_{si}$	insulation thickness on steam pipe (ft)
$N_p$	Prandtl number (dimensionless)	$x_u$	utilidor width (ft)
$q$	overall heat flow per unit length ( $\text{Btu}/\text{hr ft}$ )	$y_u$	utilidor height (ft)
$Q$	overall subsystem heat flow ( $\text{Btu}/\text{hr}$ )	$\delta$	effective thickness of air layer (ft)
$R_{ca}$	thermal resistance between the condensate pipe insulation surface and the inner wall of the utilidor ( $\text{hr ft } ^{\circ}\text{F}/\text{Btu}$ )	$\eta_o$	overall combined plant efficiency (%)
$R_{ci}$	thermal resistance of the condensate pipe insulation ( $\text{hr ft } ^{\circ}\text{F}/\text{Btu}$ )	$\Delta x_u$	utilidor wall thickness (ft)
$R_{ea}$	effective thermal resistance of air within the utilidor ( $\text{hr ft } ^{\circ}\text{F}/\text{Btu}$ )	$v_a$	kinematic viscosity of air ( $\text{ft}^2/\text{s}$ )
$R_{ei}$	effective thermal resistance of the pipe insulation ( $\text{hr ft } ^{\circ}\text{F}/\text{Btu}$ )		
$R_o$	overall thermal resistance ( $\text{hr ft } ^{\circ}\text{F}/\text{Btu}$ )		
$R_{sa}$	thermal resistance between the steam pipe insulation surface and the inner wall of the utilidor ( $\text{hr ft } ^{\circ}\text{F}/\text{Btu}$ )		
$R_{si}$	thermal resistance of the steam pipe insulation ( $\text{hr ft } ^{\circ}\text{F}/\text{Btu}$ )		
$R_u$	thermal resistance of the utilidor ( $\text{hr ft } ^{\circ}\text{F}/\text{Btu}$ )		
$S$	utilidor shape factor (dimensionless)		
$T_a$	bulk air temperature ( $^{\circ}\text{F}$ )		
$T_c$	condensate return temperature ( $^{\circ}\text{F}$ )		
$T_{ci}$	condensate pipe insulation outer surface temperature ( $^{\circ}\text{F}$ )		

# LOSSES FROM THE FORT WAINWRIGHT HEAT DISTRIBUTION SYSTEM

G.L. Phetteplace, W. Willey and M.A. Novick

## INTRODUCTION

Fort Wainwright, located near Fairbanks, Alaska, is the largest U.S. Army base located in an extremely cold climate. Winter temperatures often drop to  $-40^{\circ}\text{F}$ , and occasionally temperatures of  $-50^{\circ}\text{F}$  or lower are experienced. In such a climate, space heating can no longer be considered a comfort; it becomes a true necessity. The supply of heat must be continuous and reliable. Even a minor outage of several hours can drop indoor temperatures to below freezing.

Fort Wainwright, like many large military bases, has a central heat and power plant. This plant produces heat and electricity to meet the entire needs of the base, with the exception of some outlying buildings which are heated by other means. The purpose of this report is to examine Fort Wainwright's heat distribution system in some detail in order to estimate its efficiency.

At Fort Wainwright during the winter, heat losses from the buried heat distribution system prevent snow from accumulating over it in all but the coldest periods. Figure 1 shows the bare, dry, ground above a utilidor at Fort Wainwright during March of 1979. It's not unusual at this time of year to see children practicing baseball for the coming summer months on bare ground above the buried utilidors. After witnessing bare ground over nearly all the sections of the buried heat distribution system, it's hard to believe that the heat losses are anything but staggering.

This apparent waste of thermal energy prompted a study to determine its general magnitude. By using data from the Fort Wainwright heat and power plant, we have determined the magnitude of the heat loss and have developed a method which allows us to rapidly evaluate any proposed improvements to the system.

## THE FORT WAINWRIGHT HEAT AND POWER PLANT

Before going into detail on the Fort Wainwright heat and power plant, let's consider some of the general characteristics of combined heat and power plants.

Conventional production of electricity requires that fuel energy first be converted into heat before it can be converted into mechanical energy and eventually into electricity. The overall efficiency of this process of changing fuel to electricity is seldom over 35% in the most modern plants, and frequently less than 30% in the older facilities. The limiting factor is the conversion of heat to mechanical energy, in which only a fraction of the heat may be used. The availability of the remaining heat is too low and it must be rejected. In a conventional power plant, this waste heat is rejected to the environment by some means. In a combined heat and power plant the waste heat is used to provide heat for distribution to buildings. The waste heat, which is a liability in a conventional plant, now becomes an asset in a combined heat and power plant.



Figure 1. The ground above a buried utilidor in March at Fort Wainwright.

Table 1. Heat balances for typical electrical and combined heat and power plants.

<i>Output as percentage of fuel energy input:</i>	<i>Electricity- only plant</i>	<i>Combined heat and power plant</i>
Electricity	35	25
Waste heat	50	0
Useful heat	0	60
Stack losses	10	10
Parasitic and plant heat loss	5	5
Total	100	100

The recovery and use of this waste heat is, however, not without penalty. Normally, the heat is rejected at a temperature too low for most space-heating applications. When the heat is rejected at higher temperatures, where it can be used, a portion of electrical production is lost. Overall, however, the net efficiency of the plant is greatly increased. Consider the heat balances in Table 1, which might be typical of each type of plant during the heating season.

In the case presented in Table 1 the useful output of the plant increased from 35 to 85%. The thermal

energy is always of lesser value, however, and can usually be produced for about 25% of the cost of an equivalent amount of electrical energy. Even so, the total value of the plant output relative to electrical energy has increased from 35 to 40% [ $25+0.25(60)$ ] which represents a 14% increase. During non-heating periods a properly designed heat and power plant would be able to deliver the same efficiency as a plant that produces electricity only.

As illustrated by this example, the economic benefits of combined heat and power production are modest.

The relative energy savings, however, are of much greater magnitude. If we assume that the combined heat and power plant supplies all the heat required, we can determine the total fuel requirements for non-central heat production as follows:

$$\begin{aligned} \% \text{ heat required} &= \% \text{ of fuel input for heating} \\ &\quad \text{from a combined plant} \\ &\quad - \% \text{ of energy lost in distribution.} \end{aligned}$$

Assuming that 10% of the heat is lost in the heat distribution system and using the 60% heat output value for a combined plant from Table 1, we have

$$\text{Heat required} = 60 - 0.10(60) = 60 - 6 = 54\%$$

In a non-central heating scheme this would be supplied by individual heating plants. Their efficiency is somewhat dependent on fuel. Assuming oil is the fuel, 70% is a typical efficiency. Thus, the fuel energy required for the individual heating plant would be

$$\begin{aligned} \text{Fuel required for individual heating plants} \\ = 54/0.70 = 77\% \text{ of central plant.} \end{aligned}$$

Electric generation is somewhat more efficient for the electric-only plants. It would require only 71% [100%(25%/35%)] of the fuel required by the combined heat and power plant to generate the same amount of electricity. Thus the overall fuel use for non-central heating (77%) and central electricity production is 1.48 times that of combined heat and power production. Thus the energy saving is nearly 50%. Central heating also has the added advantage of being able to use less expensive or more plentiful fuels (i.e. coal, heavy oil, nuclear, as opposed to fuel oil and natural gas).

Now that we have discussed a few of the advantages of combined heat and power plants, let's discuss the Fort Wainwright plant in some detail. Figure 2 is a simplified flow diagram for the plant (from Rossie et al. 1975).

Steam is generated in six of the eight boilers, as the two original boilers of the plant are not operational. Each of the operating boilers is rated at 150,000 lbm of steam per hour. The steam leaves the boilers at a pressure of 400 to 420 psig, is superheated to a temperature between 650 and 750°F, and is then fed to

the turbines. The plant has five turbine-generator sets with a total nameplate capacity of 22 MW electricity. Three of the turbines are 5-MW extraction-condensing, one is a 5-MW extraction-backpressure, and the remaining one is a 2-MW extraction-condensing type. Basically, in an extraction turbine the steam is expanded partially to a lower pressure where a fraction is extracted from the turbine for space heating or industrial processes. The remaining steam continues through the low-pressure stages of the turbine. If the steam leaves the turbine below atmospheric pressure and is subsequently condensed, the turbine is called an extraction-condensing turbine. If the steam leaves the turbine at higher pressures and is used for other purposes the turbine is called an extraction-backpressure turbine. Conventional (non-extraction) turbines may be of either the backpressure or condensing type. At Fort Wainwright the extraction occurs at approximately 100 psig in all the turbines. The backpressure turbine exhausts at 10 psig and this steam is used for power plant heating.

The overall combined efficiency of both heat and electrical generation at Fort Wainwright can be calculated based on records maintained at the plant. The overall combined efficiency is simply

$$\begin{aligned} \eta_o &= \text{Overall combined plant efficiency} \\ &= \frac{\text{Steam heat out and electricity out}}{\text{fuel energy input}} \end{aligned}$$

Consider the following sample calculation for the month of January 1975. From steam tables we can find the enthalpy of 350°F steam at 105 psia (~ 90 psig) to be 1204.5 Btu/lbm. Similarly, we find the enthalpy of the condensate to be 118 Btu/lbm. The difference between these two values represents the heating energy sent out per pound-mass of steam, 1086.5 Btu/lbm. For January 1975,  $1.33 \times 10^8$  lbm of steam was sent out, along with  $9.05 \times 10^6$  kWh of electricity. In the same period 27,604 tons of coal were used. If the average heat content of the coal is assumed to be 8600 Btu/lbm, then the efficiency  $\eta_o$  is calculated as 37.0%.\*

Notice that this is less than half the efficiency of the hypothetical plant discussed earlier. Normally the Fort Wainwright heat and power plant runs at a combined efficiency of about 60%. The values are plotted for the combined efficiency over a four-year period in Figure 3. Even a 60% efficiency is significantly lower

$$* \eta_o = \frac{\left(133,103,000 \frac{\text{lbm of steam}}{\text{month}}\right) \left(1086.5 \frac{\text{Btu}}{\text{lbm of steam}}\right) + \left(9,046,000 \frac{\text{kWh}}{\text{month}}\right) \left(3413 \frac{\text{Btu}}{\text{kWh}}\right)}{27,604 \frac{\text{tons of coal}}{\text{month}} \times 2,000 \frac{\text{lbm of coal}}{\text{ton of coal}} \times 8,600 \frac{\text{Btu}}{\text{lbm of coal}}} = 37.0\%$$



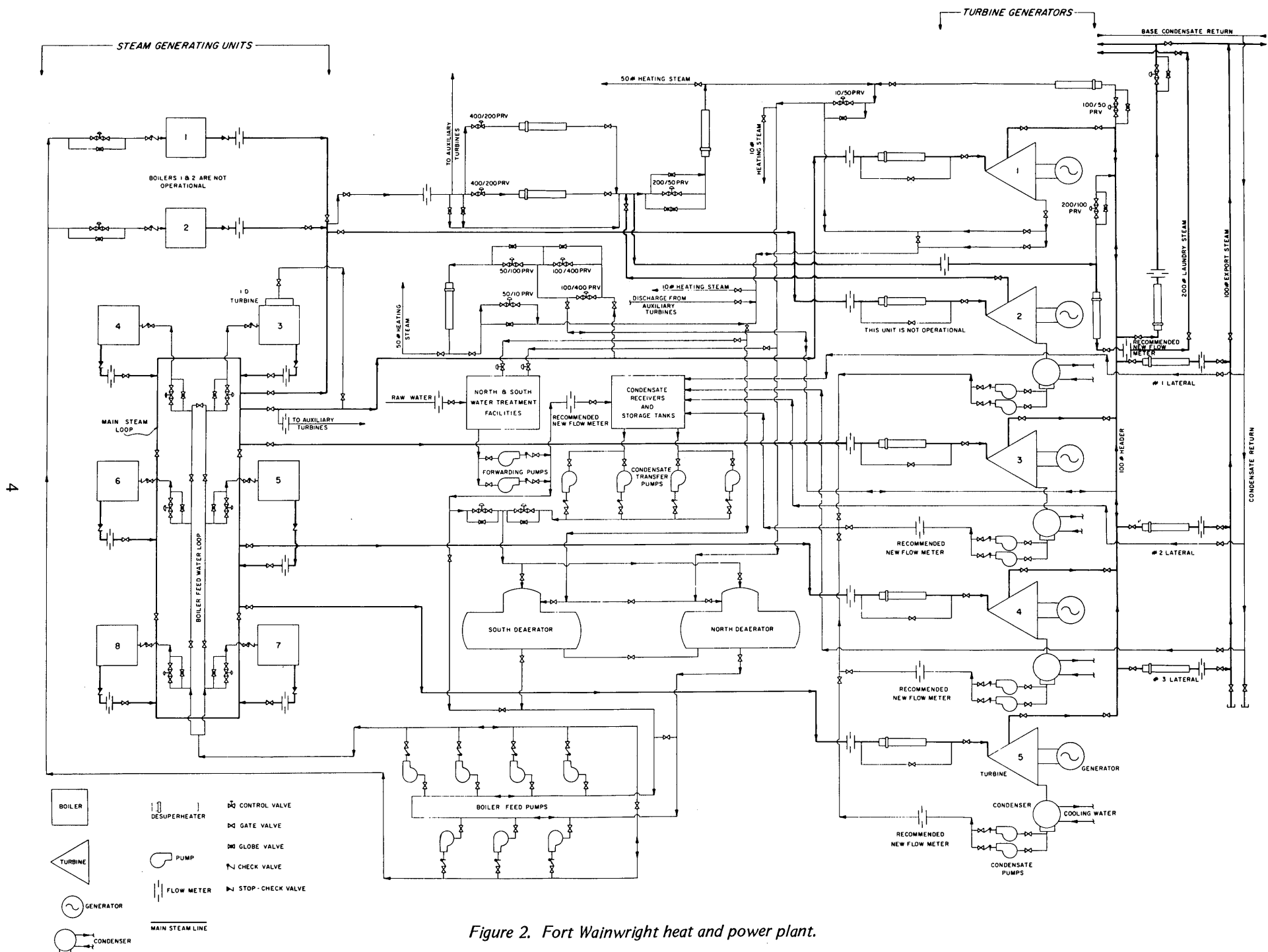

Figure 2. Fort Wainwright heat and power plant.

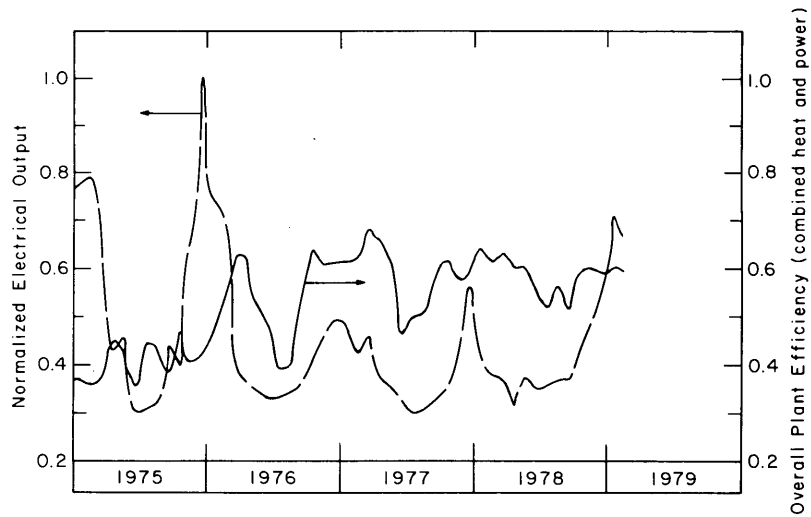

Figure 3. Overall combined plant efficiency and normalized electric output for the Fort Wainwright power plant.

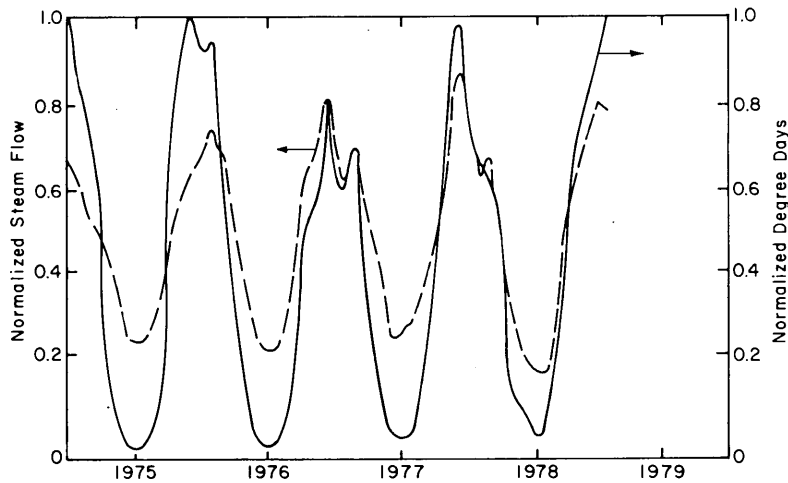

Figure 4. Steam flow and degree-day data for the Fort Wainwright power plant.

than possible, primarily due to the design of the plant itself. Steam pressure is too low for efficient electric generation, and the plant was also designed for high reliability which causes some compromise of efficiency. It still supplies heat and electricity more economically and reliably than any other method.

As can be seen from Figure 3, the electrical load of the power plant peaks in the winter months, as would certainly be expected for any electrical utility in such a climate. Figure 4 illustrates the steam flow from the plant over the same four-year period. Also shown in Figure 4 are heating degree-day data for this period. The degree-day is a measure of heating requirements, and as suspected, the steam flow from the plant follows the degree-day data closely. The one discrepancy occurs in the summer months, when heat demand is

low or nonexistent. Part of this discrepancy is due to the fact that domestic hot water is heated with steam from the distribution system and thus the load from it is relatively constant. Based on the number of residents and employees on the base, domestic hot water heating could certainly not account for more than 5% of the maximum system load. The remaining gap of about 20% is mostly due to heat losses from the piping system. These will be examined in detail below.

#### HEAT DISTRIBUTION AT FORT WAINWRIGHT

Steam extracted from the turbines at 100 psig (actually, the system has been using 90-psig steam

recently) is distributed to nearly all the buildings on base to meet both space heating and domestic hot water heating needs. In 85 to 90% of the buildings, the steam is used directly for space heating after passing through a pressure reducing valve. The remaining buildings have hot water heating systems and a water-to-steam heat exchanger.

The distribution system itself consists primarily of insulated steel pipes in utilidors. Several exceptions are pipes which are directly buried in the ground. The utilidors range in size from 1x1 ft (inside dimensions) up to 7x9 ft. The larger sizes can be easily walked in for pipe servicing. The total length of the distribution system is about 28 miles with a burial depth of between 2 and 6 ft.

Nearly all of the piping is insulated, but much of the insulation was damaged during the flood of August 1967. Part of the damaged insulation was replaced, and in other instances, insulation was added to the original insulation to restore its thermal resistance to the original value.

Complete maps of the Fort Wainwright heat distribution system were updated in 1977 and are therefore quite accurate. Using these maps, we determined the length and size of each pipe segment and tabulated this information under the appropriate category of utilidor and pipe sizes. From this table the total lengths of each configuration of utilidor, supply pipe and return pipe size were determined. Appendix A contains a table of some 200 different combinations.

## HEAT LOSSES FROM UTILIDOR SYSTEMS

The analysis of heat losses from utilidors is not a simple problem. Heat flows from the warm pipes through a series of thermal resistances to the air at the ground surface. The resistances involved are:

1. Convective heat transfer from the flowing fluid to the pipe's inner surface.
2. Conductive heat transfer through the pipe wall to the outer pipe surface.
3. Conductive heat transfer through the insulation to its outer surface.
4. Combined convective, conductive and radiative heat transfer from the insulation surface to the inner wall of the utilidor.
5. Conductive heat transfer through the utilidor wall.
6. Conductive heat transfer through the soil to the ground surface.
7. Finally, convective heat transfer to the air at the ground surface.

Fortunately, resistances 1, 2 and 7 are very small in comparison to the others and can be neglected with little error. Unfortunately, resistance 4 is very complicated. It will be treated in a simplified manner.

Consider the most complicated case, both a steam and condensate (return) pipe inside the same utilidor. (Actually, instances do occur where several steam and/or condensate pipes may share a common utilidor. In these instances, the supply and return pipes are treated as pairs and additional pipes are treated as single pipes. The total heat loss is then assumed to be the sum of all the pipes included.) The overall heat flow from the warm pipes is given as

$$q = \frac{Q}{L} = U_o(T_s - T_g) \quad (1)$$

where  $q$  = overall heat loss per unit length (Btu/hr ft)

$Q$  = overall subsystem heat loss (Btu/hr)

$L$  = subsystem length (ft)

$U_o$  = overall  $U$ -value of subsystem (Btu/hr ft °)

$T_s$  = steam temperature (°F)

$T_g$  = ground surface temperature (°F).

The overall conductance value,  $U_o$  is simply:

$$U_o = 1/R_o \quad (2)$$

where  $R_o$  is the overall thermal resistance (hr ft °F/Btu).

Since the heat flow is basically a series phenomenon, we can simply add the individual resistances to heat flow to obtain the overall resistance to heat flow  $R_o$ :

$$R_o = R_{ei} + R_{ea} + R_u + R_s \quad (3)$$

where  $R_{ei}$  = effective thermal resistance of the insulation on the pipes (hr ft °F/Btu)

$R_{ea}$  = effective thermal resistance of the air within the utilidor (hr ft °F/Btu)

$R_u$  = thermal resistance of the utilidor (hr ft °F/Btu)

$R_s$  = thermal resistance of the surrounding soil (hr ft °F/Btu)

To determine the effective thermal resistance of the pipe insulation  $R_{ei}$  we must consider the parallel heat flow from each of the pipes through its respective insulation. The sum of the two heat flows will be the total heat flow  $q$ :

$$q = \frac{T_s - T_{si}}{R_{si}} + \frac{T_c - T_{ci}}{R_{ci}} \quad (4)$$

where  $T_{si}$  = outer surface temperature of the steam pipe insulation ( $^{\circ}\text{F}$ )

$T_{ci}$  = outer surface temperature of the condensate pipe insulation ( $^{\circ}\text{F}$ )

$R_{si}$  = thermal resistance of the steam pipe insulation (hr ft  $^{\circ}\text{F}/\text{Btu}$ )

$R_{ci}$  = thermal resistance of the condensate pipe insulation (hr ft  $^{\circ}\text{F}/\text{Btu}$ )

$T_c$  = condensate return temperature ( $^{\circ}\text{F}$ ).

The total heat flow can also be written as

$$q = \frac{1}{R_{ei}} (T_s - T_{si}). \quad (5)$$

By combining eq 4 and 5 we can find the effective thermal resistance of the pipe insulation  $R_{ei}$  as

$$R_{ei} = \frac{1}{\frac{1}{R_{si}} + \frac{T_c - T_{ci}}{T_s - T_{si}} \frac{1}{R_{ci}}} \quad (6)$$

and the individual pipe insulation resistance can be calculated from the following expression (Holman 1972)

$$R_{si} = \frac{\ln[(D_s + 2X_{si})/D_s]}{2\pi k_i} \quad (7)$$

and

$$R_{ci} = \frac{\ln[(D_c + 2X_{ci})/D_c]}{2\pi k_i} \quad (8)$$

where  $D_s$  = outside diameter of the steam pipe (ft)

$X_{si}$  = insulation thickness on steam pipe (ft)

$k_i$  = insulation thermal conductivity (Btu/hr ft  $^{\circ}\text{F}$ )

$D_c$  = outside diameter of the condensate pipe (ft)

$X_{ci}$  = insulation thickness on the condensate pipe (ft).

The thermal conductivity of insulation is normally a function of its mean temperature. For calcium silicate insulation, using data from Crocker and King (1967), this function is closely approximated by

$$k_i = 0.0221 + 4.13 \times 10^{-5} T_{mi} \quad (9)$$

where  $T_{mi}$  is the average temperature of the pipe insulation ( $^{\circ}\text{F}$ ). The temperature of the steam pipe insulation is

$$T_{mi} = (T_s - T_{si})/2 \quad (10)$$

and similarly for the condensate pipe insulation

$$T_{mi} = (T_c + T_{ci})/2. \quad (11)$$

Next we need to find the effective resistance of the air  $R_{ea}$ . First, consider the heat flow equation for the air layer:

$$q = (1/R_{sa})(T_{si} - T_{ui}) + (1/R_{ca})(T_{ci} - T_{ui}) \quad (12)$$

where  $R_{sa}$  = thermal resistance between the steam pipe insulation surface and the inner wall of the utilidor (hr ft  $^{\circ}\text{F}/\text{Btu}$ )

$R_{ca}$  = thermal resistance between the condensate pipe insulation surface and the inner wall of the utilidor (hr ft  $^{\circ}\text{F}/\text{Btu}$ )

$T_{ui}$  = temperature of the inner wall of the utilidor ( $^{\circ}\text{F}$ ).

The heat flow can also be expressed in terms of the effective thermal resistance of the air  $R_{ea}$  as

$$q = 1/R_{ea} (T_{si} - T_{ui}). \quad (13)$$

By combining eq 12 and 13 we find

$$R_{ea} = \frac{1}{\frac{1}{R_{sa}} + \frac{1}{R_{ca}} \frac{(T_{ci} - T_{ui})}{(T_{si} - T_{ui})}} \quad (14)$$

Now we need to define the individual thermal resistances caused by the air layer  $R_{sa}$  and  $R_{ca}$ . As mentioned earlier, the heat transfer process within the air space is coupled convective, conductive and radiative. A full treatment is beyond the scope and requirements of this study. Instead, we will treat the air layer as a conductive medium and determine the effective thermal conductivity value  $k_{ea}$  for the medium based on published correlations for heat transfer in concentric annuli.

In order to consider this region as an annulus we must first define an effective diameter for the rectangular utilidor. The effective diameter  $D_{eu}$  is the diameter of a circular utilidor which would have the same inside surface area as the actual rectangular utilidor:

$$D_{eu} = \frac{2}{\pi} (X_u + Y_u) \quad (15)$$

where  $X_u$  is the utilidor width (ft) and  $Y_u$  the utilidor height (ft).

The effective thermal conductivity for the air within such a region is approximated by Gruber et al. (1961):

$$k_{ea} = 0.40(N_G N_P)^{0.20} \cdot k_a \quad (16)$$

within the range  $10^6 < N_G N_P < 10^9$

where  $k_{ea}$  = effective thermal conductivity of the air (Btu/hr ft °F)

$N_G$  = Grashof number (dimensionless)

$N_P$  = Prandtl number (dimensionless)

$k_a$  = thermal conductivity of air (Btu/hr ft °F).

The thermal conductivity of air  $k_a$  is a function of its temperature and can be approximated as

$$k_a = 0.01319 + 2.5 \times 10^{-5} T_a \quad (17)$$

where  $T_a$  is the bulk air temperature within the annulus (°F).

The Prandtl number of air  $N_P$  is also a function of the air temperature and can be approximated as

$$N_P = 0.7185 - 1.275 \times 10^{-4} T_a. \quad (18)$$

The bulk air temperature  $T_a$  can be approximated by the average of the effective insulation surface temperature  $T_{ei}$  and the utilidor's inner surface temperature  $T_{ui}$ :

$$T_a = (T_{ei} + T_{ui})/2. \quad (19)$$

The effective insulation surface temperature is given as the weighted average of the steam and condensate insulation surface temperatures:

$$T_{ei} = \frac{T_{si}(D_s + 2X_{si}) + T_{ci}(D_c + 2X_{ci})}{D_s + 2X_{si} + D_c + 2X_{ci}}. \quad (20)$$

The Grashof number  $N_G$  given in eq 16 is represented for this case as

$$N_G = \frac{g(T_{ei} - T_{ui})(\delta^3)}{(T_a + 459.7)(\nu_a)^2} \quad (21)$$

where  $g$  = gravitational constant (ft/s<sup>2</sup>)

$\delta$  = effective thickness of air layer (ft)

$\nu_a$  = kinematic viscosity of air (ft<sup>2</sup>/s).

The effective thickness of the air layer  $\delta$  is given by

$$\delta = \frac{D_{eu} - (D_s + 2X_{si} + D_c + 2X_{ci})}{2}. \quad (22)$$

The kinematic viscosity of air  $\nu_a$  is also a function of the air temperature  $T_a$ . It can be approximated as

$$\nu_a = 1.26 \times 10^{-4} + 5.4 \times 10^{-7} T_a. \quad (23)$$

Now that we have all of the necessary expressions

to evaluate the effective thermal conductivity of the air  $k_{ea}$ , we can find the thermal resistance due to the air space. It is simply

$$R_{sa} = \frac{\ln[D_{eu}/(D_s + 2X_{si})]}{2\pi k_{ea}} \quad (24)$$

for the steam pipe. For the condensate pipe

$$R_{ca} = \frac{\ln[D_{eu}/(D_c + 2X_{ci})]}{2\pi k_{ea}}. \quad (25)$$

The next thermal resistance which we need to define is that of the utilidor itself. It can be written as

$$R_u = \frac{\Delta X_u}{2(X_u + Y_u)k_u} \quad (26)$$

where  $\Delta X_u$  is the utilidor wall thickness (ft) and  $k_u$  is the thermal conductivity of the utilidor material (Btu/hr ft °F).

And, finally, the last thermal resistance we need to define is that of the soil system:

$$R_s = 1/k_s S \quad (27)$$

where  $k_s$  is the thermal conductivity of the soil (Btu/hr ft °F) and  $S$  is the shape factor of the utilidor (dimensionless).

For a rectangular utilidor the shape factor  $S$  is given (from Holman 1972) as

$$S = 1.685 \left\{ \left[ \log \left( 1 + \frac{X_B}{X_u} \right) \right]^{-0.59} + \left( \frac{X_B}{Y_u} \right)^{-0.078} \right\} \quad (28)$$

where  $X_B$  is the utilidor burial depth (ft).

Now we have expressions for all the thermal resistances given in eq 3. With these we can find the heat loss from the utilidor. The calculation procedure is not completely straightforward, however.

Notice that both the effective thermal resistance of the pipe insulation  $R_{ei}$  and the effective thermal resistance of the air space  $R_{ea}$  are functions of temperatures which are not initially known. It is necessary, therefore, for us to solve this problem iteratively. To do so we first guess at the unknown required temperatures. We then use the procedure outlined to calculate the heat flow  $q$ . Given this result we can calculate the outer surface temperature of the utilidor  $T_{uo}$  by

$$T_{uo} = T_g + qR_s \quad (29)$$

and similarly the inner surface temperature of the utilidor is given as

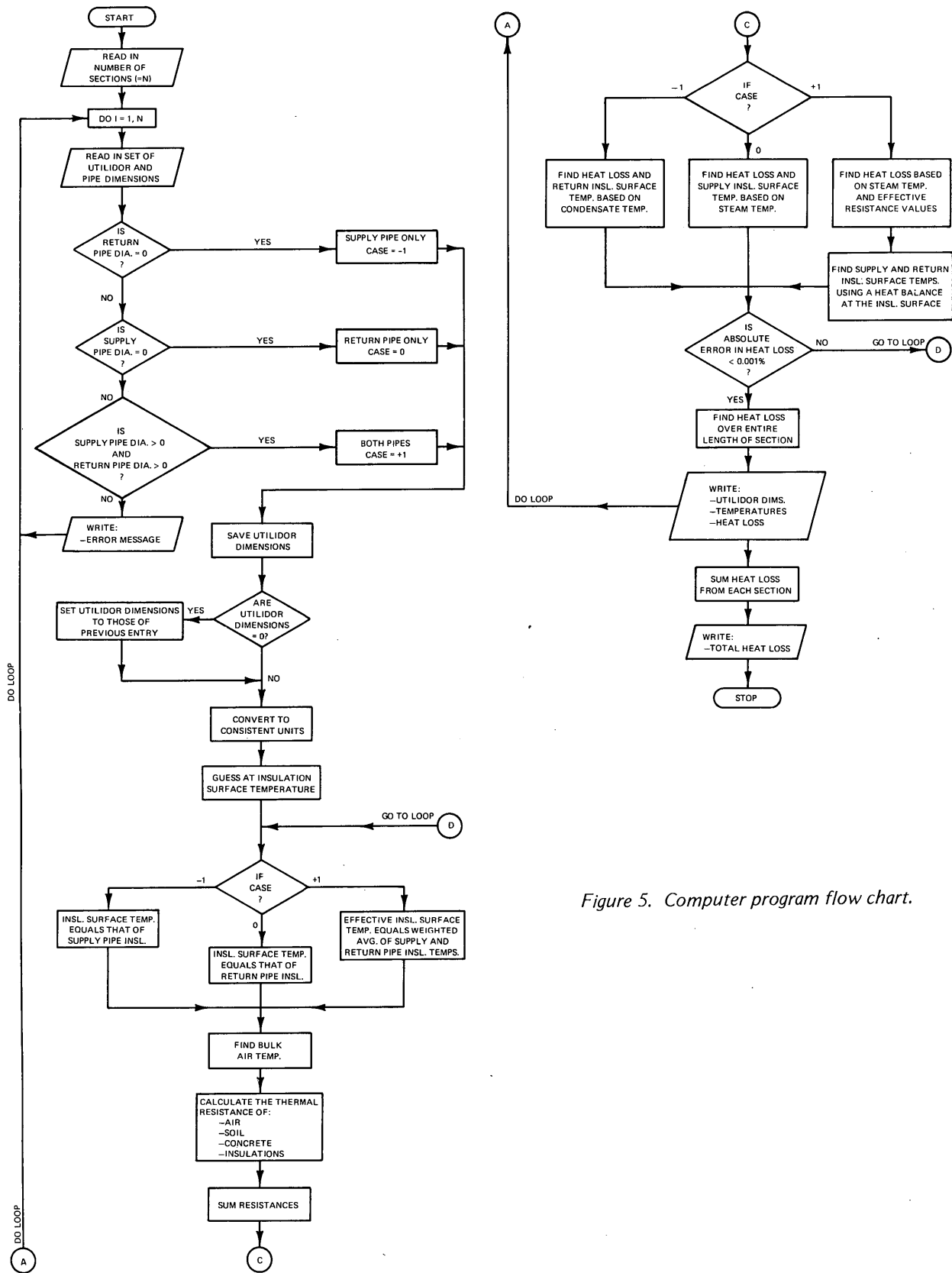

Figure 5. Computer program flow chart.

$$T_{ui} = T_{uo} + qR_{u_i} \quad (30)$$

Now we need to recalculate the insulation surface temperatures  $T_{si}$  and  $T_{ci}$ . We can do this by considering a heat balance at the insulation surface and using the new value for the utilidor inner surface temperature  $T_{ui}$  just calculated. The heat balance gives the following equations:

$$T_{si} = \frac{T_s}{1 + (R_{si}/R_{sa})} + \frac{T_{ui}}{1 + (R_{sa}/R_{si})} \quad (31)$$

and

$$T_{ci} = \frac{T_c}{1 + (R_{ci}/R_{ca})} + \frac{T_{ui}}{1 + (R_{ca}/R_{ci})} \quad (32)$$

Now we can use these new temperatures to recalculate the heat loss  $q$ . If the heat loss is close to the value previously calculated, we have found the answer; if it is not we must recalculate the temperatures and heat loss again. This process continues until the heat loss value has stabilized and the answer is found. A similar, but simpler, procedure can be used for single pipes in utilidors.

A computer program written to accomplish this calculation procedure for an entire heat distribution system is listed in Appendix B. A flow chart of the program is given in Figure 5. In Appendix C, sample

input and output data for the program are given.

The advantages of computer implementation of this calculation scheme are obvious. As well as allowing us to determine the heat loss of any heat distribution system using utilidors, it allows us to evaluate modification to the system or operating parameters to determine their effect. In the next section we will examine the results for the Fort Wainwright heat distribution system. Modifications and their effect will also be studied.

## SYSTEM EFFICIENCY AND POSSIBLE IMPROVEMENTS

Using a computer program following the method outlined above, we have found the total heat loss from the distribution system to be  $2.045 \times 10^5$  MBtu/yr. This value assumes that the average annual air temperature of  $25.7^\circ\text{F}$  can be used as the ground surface temperature. It also assumes that all pipes are insulated with 1 in. of calcium silicate insulation.

The heat loss from the utilidor system actually varies over the course of the year due to the fluctuations in the ground surface temperature. Figure 6 shows how the air temperature varies over an average year as well as its effect on the heat loss. The temperatures used in this case represent the average monthly air temperatures for the Fairbanks area.

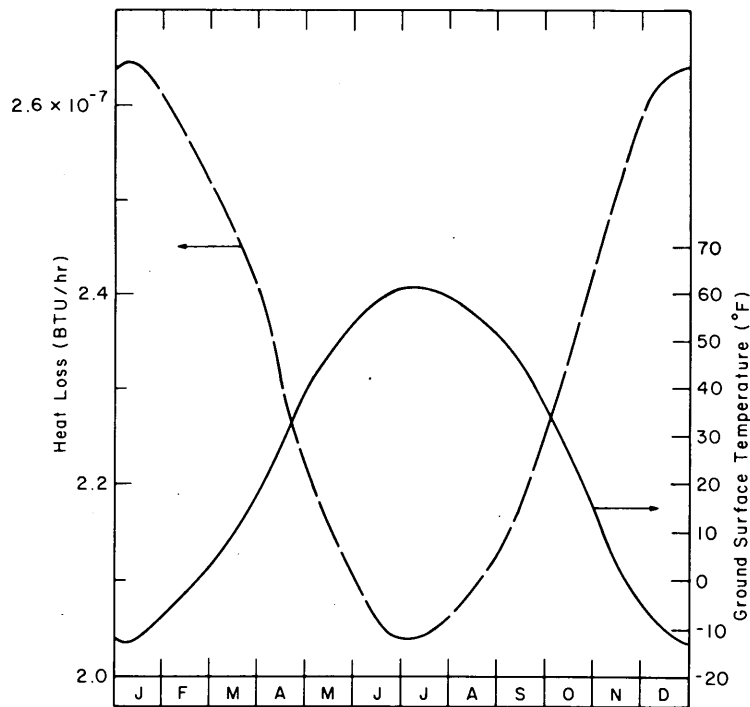

Figure 6. Ground surface temperature and heat losses for an average year.

For a more specific case, calendar year 1978, let's compare the heat loss over the course of the year with the heat supplied to the distribution system. We can express the heat supplied to the system over the course of the year in terms of British Thermal Units by recalling that each pound-mass of steam represents 1086.5 Btu of heat at the average steam and condensate conditions. Table 2 summarizes the plant input to the system as well as the calculated losses.

The estimated percentage heat loss during the

month of August is more than double that of the month of January, based in each case on the heat exported from the power plant. This is due to the small heat loss fluctuations over the yearly cycle compared to the steam flow from the plant that varies to a greater extent. If we normalize each of these, that is divide them by the largest value over the year, this effect is clearly illustrated. Figure 7 gives the normalized heat export by the plant as well as the normalized heat loss for the 1978 calendar year.

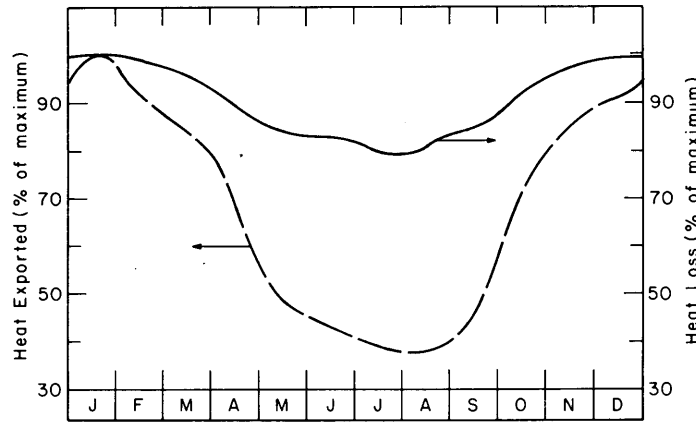

Figure 7. Normalized heat export and heat loss for 1978.

Table 2. Exported heat and calculated heat losses for calendar year 1978.

Month	Days	Steam exported (klbm)	Average rate of heat export (MBtu/hr)	Average air temperature (°F)	Calculated rate of heat loss (MBtu/hr)	Rate of heat loss as percentage of rate of heat exported (%)	Normalized rate of heat export (%)	Normalized rate of heat loss (%)
Jan	31	151,633	221.4	0.1	25.4	11.5	100.0	100.0
Feb	28	125,540	203.0	3.9	25.1	12.4	91.7	98.8
Mar	31	127,576	186.3	14.0	24.3	13.0	84.1	95.7
Apr	30	100,559	151.7	34.8	22.6	14.9	68.5	89.0
May	31	73,413	107.2	50.2	21.3	19.9	48.4	83.9
June	30	63,516	95.8	54.6	21.0	21.9	43.3	82.7
July	31	59,134	86.4	63.5	20.2	23.4	39.0	79.5
Aug	31	57,309	83.7	59.5	20.6	24.6	37.8	81.1
Sept	30	66,324	100.1	46.8	21.6	21.6	45.2	85.0
Oct	31	107,812	157.4	23.3	23.5	14.9	71.1	92.5
Nov	30	125,039	188.7	8.6	24.7	13.1	85.2	97.2
Dec	31	137,662	201.0	3.3	25.2	12.5	90.8	99.2
Total	365	1,195,517	—	—	—	—	—	—
Averages	30.4	99,626	148.6	30.2	23.0	15.5	67.1	90.4



Table 3. The effect of increasing insulation thickness on all pipes.

Case	Steam pipe ins. thickness (in.)	Condensate pipe ins. thickness (in.)	Total heat loss (MBtu/yr)	Change in heat loss (MBtu/yr)	Total ins. volume (ft <sup>3</sup> )	Change in ins. volume (ft <sup>3</sup> )	Heat savings per unit of insulation added (MBtu/yr ft <sup>3</sup> )
Reference	1	1	2.045×10 <sup>5</sup>	—	1.202×10 <sup>5</sup>	—	—
1	1	2	1.920×10 <sup>5</sup>	- 1.25×10 <sup>4</sup>	1.788×10 <sup>5</sup>	5.860×10 <sup>4</sup>	0.2133
2	2	1	1.551×10 <sup>5</sup>	-4.940×10 <sup>4</sup>	1.817×10 <sup>5</sup>	6.150×10 <sup>4</sup>	0.8033
3	2	2	1.430×10 <sup>5</sup>	-6.150×10 <sup>4</sup>	2.403×10 <sup>5</sup>	1.201×10 <sup>5</sup>	0.5121
4	3	1	1.317×10 <sup>5</sup>	-7.280×10 <sup>4</sup>	2.432×10 <sup>5</sup>	1.230×10 <sup>5</sup>	0.5919
5	3	2	1.198×10 <sup>5</sup>	-8.470×10 <sup>4</sup>	3.019×10 <sup>5</sup>	1.817×10 <sup>5</sup>	0.4662

Table 4. The effect of increasing insulation thickness of pipes in utilidors 3½ ft by 3½ ft or larger.

Case	Steam pipe ins. thickness (in.)	Condensate pipe ins. thickness (in.)	Total heat loss (MBtu/yr)	Change in heat loss (MBtu/yr)	Total ins. volume (ft <sup>3</sup> )	Change in ins. volume (ft <sup>3</sup> )	Heat savings per unit of insulation added (MBtu/yr ft <sup>3</sup> )
Reference	1	1	2.045×10 <sup>5</sup>	—	1.202×10 <sup>5</sup>	—	—
1	1	2	1.940×10 <sup>5</sup>	-1.050×10 <sup>4</sup>	1.649×10 <sup>5</sup>	4.470×10 <sup>4</sup>	0.2349
2	2	1	1.621×10 <sup>5</sup>	-4.240×10 <sup>4</sup>	1.677×10 <sup>5</sup>	4.750×10 <sup>4</sup>	0.8926
3	2	2	1.518×10 <sup>5</sup>	-5.270×10 <sup>4</sup>	2.125×10 <sup>5</sup>	9.230×10 <sup>4</sup>	0.5710
4	3	1	1.419×10 <sup>5</sup>	-6.260×10 <sup>4</sup>	2.152×10 <sup>5</sup>	9.500×10 <sup>4</sup>	0.6589
5	3	2	1.317×10 <sup>5</sup>	-7.280×10 <sup>4</sup>	2.600×10 <sup>5</sup>	1.398×10 <sup>5</sup>	0.5207

As stated earlier, the heat loss for an average year is approximately  $2.045 \times 10^5$  MBtu. During 1979 the cost of heat at Fort Wainwright was about \$4.60/MBtu. Thus, the yearly cost of heat loss is about \$940,000. With energy costs rising as they are, this cost will soon be over one million dollars per year. Let us now consider some possible improvements to the system and their effect on heat losses.

The most obvious method of reducing heat losses is to increase insulation thickness on the pipes. This is, however, a very expensive proposition. Although we will not try to assess the cost of increasing insulation thicknesses, we will provide data on its anticipated effect on heat losses from the system. Table 3 gives the results of several sets of calculations with varying insulation thicknesses. Also given are the volumes and the increases over the current amount.

In the last column of Table 3 the heat savings per unit of insulation added are given. These quantities in conjunction with the cost of insulation would allow one to examine the relative economics of each case. As can be seen from the table, case 2 offers the best opportunity for being economically viable. The heat savings per unit of insulation added are also relatively high for case 4. In each of these cases, all additional pipe insulation was added to the steam pipes alone.

Another possibility investigated was insulating only the pipes in the larger size utilidors. Access to these

pipes would be easier since these utilidors can be entered, as opposed to smaller utilidors which would need to be excavated; thus the economics for this situation should be more attractive. Table 4 gives results similar to Table 3 except that only pipes in utilidors 3½x 3½ ft or larger received additional pipe insulation.

As before, case 2 is still the most attractive and case 4 is the next best. Also notice that in each case the heat saving per unit of insulation added is greater than for the same case when all the pipes were reinsulated. This, coupled with the fact that these pipes in the larger utilidors should be easier to insulate, indicates case 2 as the best approach. In addition, it seems likely that larger pipes, which are normally in the larger utilidors, would be easier to insulate in themselves. This would result in still lower insulating costs.

Another method which could be used to reduce heat losses is to reduce the distribution temperature of steam. Currently steam conditions are approximately 90 psig and 375°F, although the saturation temperature of 90 psig steam is about 331°F. Thus, the steam has about 44°F of superheat. If this amount of superheat and/or the distribution pressure were reduced (i.e. saturation pressure of steam reduced), the heat losses could also be reduced. This option was studied only to the extent of determining what the resulting heat losses would be for any given steam temperature. Figure 8 shows the effect of steam temperature on the total system heat losses.

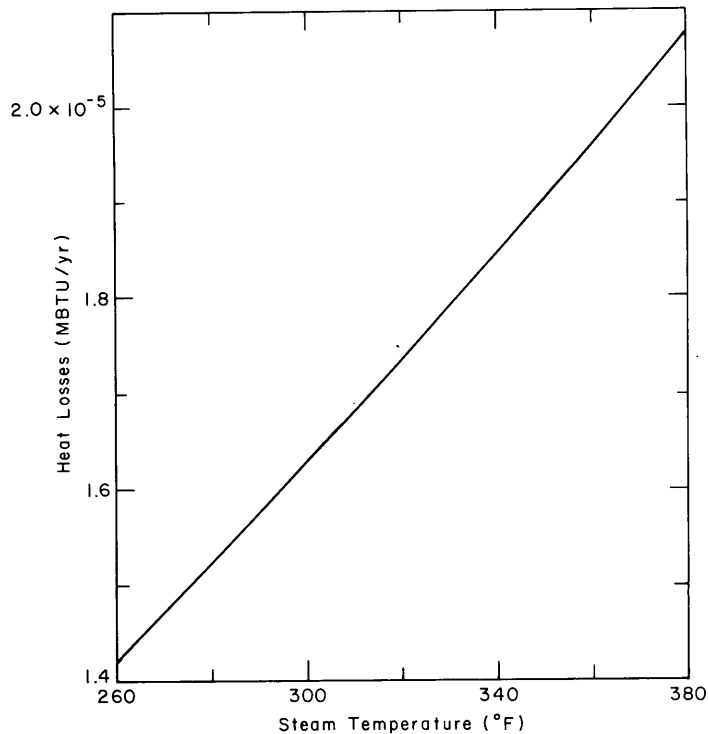

Figure 8. System heat losses as a function of steam temperature.

We feel that insulating the steam pipes in the larger utilidors and reducing the steam temperature hold the most promise for reducing heat losses from the Fort Wainwright system. Although other possibilities may exist, they will not be studied here. These two methods would produce the following cost savings.

1. Additional pipe insulation. Based on the limited input data, the most promising alternative would be to add insulation, probably on the order of an inch or so, to the steam pipes only. It is most likely that this alternative would be the most attractive from an economic viewpoint. Using 10% as the time value of money and 5% as the escalation rate for coal (see U.S. Army Corps of Engineers 1978) we can calculate the present worth of the heat savings resulting from the addition of insulation. For case 2 from Table 3 (addition of one inch of insulation to the steam line only) the reduction in heat loss is  $4.94 \times 10^4$  MBtu/yr. For 1979 the heat cost at Fort Wainwright was \$4.60/MBtu (from Flanders and Coutts, in prep.). Of this \$2.10 per MBtu is attributable to fuel costs with the remaining \$2.50 per MBtu attributable to ownership, operations and maintenance costs. If we assume that the insulation added will have a useful lifetime of 20 years, the present value of the heat savings is \$2,307,770\* where the multiplication factors (12.11 and 8.51) are the

present worth factors for escalating fuel cost savings and fixed plant savings, respectively.

This represents the maximum amount which could be justified for adding one inch of insulation to the steam pipes only.

2. Lower steam temperature. Lower steam temperatures could also result in significant reductions in distribution system heat losses. For instance, a reduction in supply temperature from 375°F to 320°F would result in more than 15% reduction in heat losses. The reduction in supply temperature could be made up of a reduction in steam superheat as well as reduced steam saturation temperature due to reduced pressure. An analysis similar to the one above gives the present value of future heat savings as \$1,433,013. Since this might well be accomplished with little or no investment, it's very attractive.

## CONCLUSIONS AND RECOMMENDATIONS

Several major opportunities exist for reducing the heat losses from the Fort Wainwright heat distribution system. During the average year the cost of heat loss approaches one million dollars. The two most promising alternatives, adding 1 inch of insulation to the steam

$$* PV = 4.94 \times 10^4 \text{ MBtu} \left[ \left( 2.10 \frac{\$}{\text{MBtu}} \times 12.11 \right) + \left( 2.50 \frac{\$}{\text{MBtu}} \times 8.51 \right) \right]$$

pipes in the larger utilidors and decreasing the steam temperature from 375° to 320°F, were found to offer the potential for significant savings.

Each of these alternatives merits further study. The results of this work are limited primarily by the quality of the input data. More detailed studies should be performed before any alternative is undertaken. Thus, our recommendations will deal with refinements to this study which would yield results of higher confidence. Our recommendations are listed below:

1. Establish more accurate estimates as to the thickness and condition of the existing pipe insulation. Laboratory measurements of the thermal conductivity of actual samples of the insulation are also needed. These tests are relatively routine.

2. Determine the thermal characteristics of the soil system around typical utilidors. The long-term effects of such a heat source within the soil may significantly effect the thermal properties of the soil by drying it out.

3. Obtain more accurate geometric data on the utilidors. These data would include exact interior and exterior dimensions, burial depth and location of the various utilities within.

4. Make temperature measurements within utilidors to estimate the accuracy of the heat loss computational procedure. Heat flux meters could also be installed in representative utilidors for further confirmation.

5. Refine the methods used in the computational procedure for determining the heat losses. Use several full numerical models to investigate selected utilidor configurations.

6. Investigate the consequences of lowering steam pressure (saturation temperature) and/or steam superheat to obtain lower overall steam temperatures.

7. Make preliminary estimates of the cost of implementing the suggestions put forth in this study. If warranted, make more detailed estimates of the attractive alternatives.

## LITERATURE CITED

Crocker, S. and R.C. King (1967) *Piping handbook*. New York: McGraw-Hill, 5th edition.

Flanders, S.N. and H.J. Coutts (In prep.) Least life cycle costs for insulation in Alaska. U.S. Army Cold Regions Research and Engineering Laboratory (CRREL) Report.

Gröber, H., S. Erk and U. Grigull (1961) *Fundamentals of heat transfer*. New York: McGraw-Hill.

Holman, J.P. (1972) *Heat transfer*. New York: McGraw-Hill, 3rd edition.

Rossie, J.P. and R.C. Johnson (1975) Fort Wainwright, Alaska, central heat and power plant power system study. R.W. Beck and Associates, Seattle, Washington.

U.S. Army Corps of Engineers (1978) Energy conservation investment program guidance. Facility Engineers Support Agency.

## APPENDIX A: HEAT DISTRIBUTION SYSTEM DATA

Combination Number	Utilidor Dimensions (ft)		Supply pipe diameter (in)	Return pipe diameter (in)	Length (ft)
	Width	Height			
1	1.00	1.00	1.50	1.00	100.0
2	1.50	1.50	0.00	1.00	130.0
3	1.50	2.00	2.00	0.00	140.0
4	2.00	2.00	1.25	1.00	35.0
5	2.00	2.00	2.00	2.00	1280.0
6	2.00	2.00	2.50	2.00	195.0
7	2.00	2.00	3.00	1.25	100.0
8	2.00	2.00	3.00	1.50	150.0
9	2.00	2.00	4.00	2.00	170.0
10	2.00	2.00	5.00	1.50	60.0
11	2.00	2.00	10.00	6.00	35.0
12	2.00	1.50	2.00	1.00	30.0
13	2.00	2.50	2.00	1.00	325.0
14	2.00	2.50	2.00	2.00	275.0
15	2.00	2.50	6.00	2.50	620.0
16	2.00	3.00	6.00	2.50	620.0
17	2.00	4.00	2.00	1.50	120.0
18	2.00	4.00	3.00	2.00	275.0
19	2.42	2.42	2.50	1.00	190.0
20	2.50	2.00	2.00	2.00	150.0
21	2.50	2.00	6.00	2.50	25.0
22	2.50	2.00	6.00	0.00	30.0
23	2.50	2.50	2.00	2.00	65.0
24	2.50	3.00	6.00	4.00	225.0
25	2.50	3.00	8.00	4.00	190.0
26	2.50	3.50	4.00	2.00	30.0
27	3.00	2.00	8.00	2.00	415.0
28	3.00	2.50	3.00	1.50	60.0
29	3.00	2.75	3.00	1.00	100.0
30	3.00	2.75	4.00	2.00	510.0
31	3.00	3.00	1.00	1.00	70.0
32	3.00	3.00	1.50	1.50	50.0
33	3.00	3.00	2.00	1.50	80.0
34	3.00	3.00	2.00	1.25	55.0
35	3.00	3.00	2.00	2.00	550.0
36	3.00	3.00	2.50	1.00	75.0
37	3.00	3.00	2.50	1.50	230.0
38	3.00	3.00	3.00	1.50	635.0
39	3.00	3.00	3.00	2.00	575.0
40	3.00	3.00	4.00	2.00	395.0
41	3.00	3.00	6.00	2.00	305.0
42	3.00	3.00	6.00	3.00	670.0
43	3.00	3.00	8.00	2.00	620.0
44	3.00	3.00	8.00	4.00	270.0
45	3.00	3.00	8.00	4.00	210.0
46	3.06	0.00	6.00	0.00	0.0*
47	3.00	3.50	1.25	1.25	330.0
48	3.00	3.50	1.50	1.50	60.0
49	3.00	3.50	2.00	1.00	260.0
50	3.00	3.50	2.00	1.50	805.2
51	3.00	3.50	2.00	2.00	60.0
52	3.00	3.50	2.50	1.50	965.0
53	3.00	3.50	3.00	1.25	330.0
54	3.00	3.50	3.00	1.50	935.0
55	3.00	3.50	3.00	2.00	675.0
56	3.00	3.50	3.50	2.00	75.0
57	3.00	3.50	4.00	2.00	6360.0
58	3.00	3.50	5.00	2.50	45.0
59	3.00	3.50	6.00	2.00	525.0
60	3.00	3.50	6.00	3.00	650.0
61	3.00	3.50	8.00	4.00	700.0
62	3.00	4.00	2.00	1.00	40.0
63	3.00	4.00	3.00	2.00	270.0
64	3.00	4.00	4.00	3.00	465.0
65	3.00	4.00	6.00	3.00	50.0
66	3.00	5.00	2.00	2.00	65.0
67	3.50	3.00	2.50	1.00	160.0
68	3.50	3.00	4.00	2.00	150.0
69	3.50	3.00	6.00	2.50	150.0
70	3.50	3.00	6.00	3.00	520.0

Combination Number	Utilidor Dimensions (ft)		Supply pipe diameter (in)	Return pipe diameter (in)	Length (ft)
	Width	Height			
71	3.50	3.50	1.50	1.50	70.0
72	3.50	3.50	6.00	3.00	420.0
73	3.50	3.50	8.00	4.00	50.0
74	3.50	4.50	6.00	4.00	520.0
75	4.00	3.00	3.00	2.00	500.0
76	4.00	3.00	3.50	2.50	345.0
77	4.00	4.00	3.00	2.00	90.0
78	4.00	4.00	4.00	2.00	515.0
79	4.00	4.00	6.00	2.00	410.0
80	4.00	4.00	6.00	3.00	510.0
81	4.00	4.00	8.00	2.00	100.0
82	4.00	5.00	1.00	1.00	120.0
83	4.00	5.00	2.00	0.00	130.0
84	4.00	5.00	0.00	2.00	290.0
85	4.00	5.00	3.00	1.50	100.0
86	4.00	5.00	4.00	2.00	260.0
87	4.00	5.00	4.00	2.50	240.0
88	0.00	0.00	0.00	6.00	0.0
89	4.00	5.00	5.00	3.50	400.0
90	4.00	5.00	6.00	2.50	40.0
91	4.00	5.00	6.00	3.00	370.0
92	4.00	5.00	6.00	4.00	270.0
93	4.00	5.00	6.00	0.00	200.0
94	4.00	5.00	8.00	3.00	730.0
95	4.00	5.00	8.00	4.00	1015.0
96	4.00	5.00	10.00	4.00	180.0
97	4.00	5.00	10.00	6.00	1200.0
98	4.50	4.00	6.00	2.00	190.0
99	4.50	5.00	3.00	1.00	320.0
100	4.50	5.00	3.00	2.00	190.0
101	4.50	5.00	3.50	2.00	145.0
102	0.00	0.00	0.00	1.25	0.0*
103	4.50	5.00	5.00	2.00	230.0
104	4.50	5.00	6.00	3.00	555.0
105	4.50	5.00	10.00	4.00	365.0
106	4.50	4.50	4.00	2.00	770.0
107	4.50	4.50	6.00	2.00	240.0
108	4.50	4.50	8.00	4.00	960.0
109	4.50	4.50	10.00	4.00	170.0
110	4.50	4.50	12.00	6.00	825.0
111	5.00	4.00	8.00	4.00	460.0
112	5.00	4.75	12.00	8.00	450.0
113	5.00	5.00	1.00	1.00	130.0
114	5.00	5.00	1.00	1.00	410.0
115	0.00	0.00	8.00	4.00	0.0*
116	5.00	5.00	1.25	1.25	425.0
117	5.00	5.00	1.50	1.25	170.0
118	0.00	0.00	6.00	3.00	0.0*
119	5.00	5.00	2.00	1.00	400.0
120	5.00	5.00	2.00	2.00	310.0
121	5.00	5.00	3.00	1.25	190.0
122	5.00	5.00	3.00	1.50	125.0
123	5.00	5.00	3.00	2.00	300.0
124	5.00	5.00	4.00	1.50	155.0
125	5.00	5.00	4.00	2.00	2315.0
126	5.00	5.00	4.00	2.00	400.0
127	0.00	0.00	2.00	0.00	0.0*
128	5.00	5.00	6.00	2.50	1115.0
129	5.00	5.00	6.00	3.25	355.0
130	0.00	0.00	2.00	1.25	0.0*
131	5.00	5.00	6.00	3.00	500.0
132	5.00	5.00	6.00	4.00	120.0
133	5.00	5.00	2.50	1.25	2800.0
134	0.00	0.00	8.00	0.00	0.0*
135	5.00	5.00	8.00	3.00	410.0
136	0.00	0.00	1.50	1.50	0.0*
137	0.00	0.00	0.00	1.25	0.0*
138	5.00	5.00	8.00	4.00	6285.0
139	5.00	5.00	8.00	4.00	400.0

Combination Number	Utilidor Dimensions (ft)		Supply pipe diameter	Return pipe diameter	Length (ft)
	Width	Height	(in)	(in)	
140	0.00	0.00	0.00	3.00	0.0*
141	0.00	0.00	0.00	1.50	0.0*
142	5.00	5.00	8.00	6.00	840.0
143	5.00	5.00	10.00	4.00	4785.0
144	5.00	5.00	10.00	3.00	420.0
145	0.00	0.00	4.00	0.00	0.0*
146	5.00	5.00	10.00	5.00	180.0
147	0.00	0.00	4.00	0.00	0.0*
148	5.00	5.00	10.00	6.00	6605.0
149	5.00	5.00	12.00	5.00	240.0
150	5.00	5.00	12.00	6.00	3020.0
151	5.00	5.00	12.00	8.00	875.0
152	5.00	5.00	16.00	8.00	750.0
153	5.33	6.00	1.50	1.25	130.0
154	0.00	0.00	6.00	3.00	0.0*
155	5.50	4.50	6.00	2.00	1150.0
156	5.50	5.00	4.00	2.00	120.0
157	5.50	5.50	8.00	3.00	1285.0
158	5.50	5.50	10.00	3.00	345.0
159	5.50	5.50	10.00	4.00	410.0
160	5.50	5.50	10.00	6.00	1545.0
161	6.00	4.00	14.00	8.00	415.0
162	6.00	5.00	10.00	4.00	390.0
163	6.00	6.00	10.00	6.00	390.0
164	0.00	0.00	4.00	0.00	0.0*
165	6.00	6.00	10.00	6.00	1060.0
166	6.00	6.00	14.00	8.00	250.0
167	6.00	6.00	16.00	10.00	1040.0
168	6.00	6.50	14.00	8.00	365.0
169	6.00	6.50	16.00	8.00	105.0
170	6.00	6.50	20.00	10.00	1550.0
171	6.00	7.00	1.50	1.00	705.0
172	6.00	7.00	5.00	2.50	1010.0
173	6.00	7.00	2.50	2.00	200.0
174	0.00	0.00	5.00	2.50	0.0*
175	6.00	7.00	2.50	2.50	210.0
176	0.00	0.00	5.00	2.50	0.0*
177	6.00	7.00	6.00	2.50	330.0
178	6.00	7.00	3.00	1.25	300.0
179	0.00	0.00	6.00	0.00	0.0*
180	6.00	7.00	6.00	4.00	200.0
181	6.00	7.00	8.00	4.00	1870.0
182	6.00	7.00	8.00	6.00	370.0
183	0.00	0.00	0.00	1.25	0.0*
184	6.00	7.17	3.50	1.00	300.0
185	0.00	0.00	2.00	0.00	0.0*
186	0.00	0.00	1.00	0.00	0.0*
187	6.00	7.17	12.00	6.00	300.0
188	6.00	7.17	12.00	8.00	2110.0
189	6.00	7.50	16.00	10.00	240.0
190	0.00	0.00	4.00	0.00	0.0*
191	6.00	7.50	18.00	10.00	450.0
192	0.00	0.00	4.00	0.00	0.0*
193	6.00	7.50	18.00	10.00	100.0
194	0.00	0.00	4.00	0.00	0.0*
195	6.00	7.50	24.00	10.00	190.0
196	6.00	8.00	8.00	3.00	400.0
197	6.50	5.50	10.00	6.00	100.0
198	7.00	7.00	12.00	6.00	880.0
199	7.00	7.00	12.00	8.00	2605.0
200	7.00	7.00	16.00	8.00	3915.0
201	7.00	7.00	18.00	8.00	1830.0
202	7.00	7.50	24.00	10.00	210.0
203	0.00	0.00	4.00	0.00	0.0*
204	7.00	7.50	24.00	12.00	180.0
205	7.00	9.00	1.50	5.00	60.0
206	7.00	9.00	2.00	2.00	250.0
207	7.00	9.00	3.00	1.50	40.0
208	7.00	9.00	5.00	2.00	40.0
209	7.00	9.00	5.00	1.50	90.0
210	7.00	9.00	12.00	5.00	130.0

Combination Number	Utilidor Dimensions (ft)		Supply pipe diameter (in)	Return pipe diameter (in)	Length (ft)
	Width	Height			
211	0.00	0.00	5.00	0.00	0.0*
212	7.00	9.00	14.00	5.00	50.0
213	0.00	0.00	5.00	0.00	0.0*
214	7.00	9.00	2.50	1.25	40.0
215	0.00	0.00	8.00	0.00	0.0*
216	7.00	9.00	10.00	2.00	100.0
217	7.00	9.00	10.00	6.00	290.0
218	0.00	0.00	10.00	5.00	0.0*
219	7.00	9.00	10.00	6.00	320.0
220	0.00	0.00	12.00	5.00	0.0*
221	0.00	0.00	3.00	0.00	0.0*
222	7.00	9.00	10.00	6.00	290.0
223	0.00	0.00	14.00	5.00	0.0*
224	0.00	0.00	3.00	0.00	0.0*
225	7.00	9.00	10.00	5.00	80.0
226	0.00	0.00	14.00	6.00	0.0*
227	7.00	9.00	12.00	5.00	90.0
228	7.00	9.00	12.00	5.00	280.0
229	0.00	0.00	5.00	0.00	0.0*
230	7.00	9.00	8.00	1.50	40.0
231	7.00	9.00	10.00	5.00	90.0
232	7.50	6.00	20.00	10.00	450.0

\* Note: In instances where the utilidor dimensions and length are zero, pipes are contained in preceeding utilidor. In addition 3 pipes were inadvertently left out of the computer input file. This, unfortunately, was not noticed until all calculations were complete. Since the error caused by this mistake is of the order of less than 1/2%, the calculations were not redone.





MORE THAN  
 2 PIPES: ENTER FIRST TWO (2) PIPES AS ABOVE. THEN ON A  
 NEW DATA LINE ENTER ZEROS (0) FOR ALL UTILIDOR  
 DIMENSIONS AND ENTER DIAMETER OF PIPE IN CORRECT  
 CATEGORY.

ZERO DIMENSIONS FOR UTILIDOR CAN BE ADDED INDEFINITELY TO  
 INDICATE ANY NUMBER OF PIPES.

FOLLOWING IS A LIST OF THE SIGNIFICANT PROGRAM VARIABLES.

BD= BURIAL DEPTH OF UTILIDOR (FT)  
 EFAIRC= EFFECTIVE AIR CONDUCTIVITY (BTU/HR\*FT\*F)  
 EFUD= EFFECTIVE UTILIDOR DIAMETER (FT)  
 GRSHOF= GRASHOF NUMBER  
 HLOSS= HEAT LOSS (BTU/HR\*FT)  
 HTCA= HEAT TRANSFER COEFFICIENT OF AIR (BTU/HR\*FT\*F)  
 HTCIC= HEAT TRANSFER COEFFICIENT OF INSULATION (BTU/HR\*FT\*F)  
 PERU= PERIMETER OF UTILIDOR (FT)  
 PRANTL= PRANDTL NUMBER  
 RAIR= THERMAL RESISTANCE OF AIR (HR\*FT\*F/BTU)  
 RCONC= THERMAL RESISTANCE OF CONCRETE (HR\*FT\*F/RTU)  
 RINS(S)(R)= THERMAL RESISTANCE OF INSULATION (SUPPLY)(RETURN)  
 (HR\*FT\*F/BTU)  
 RIR= RETURN PIPE INSULATION RADIUS (FT)  
 RITHK= RETURN PIPE INSULATION THICKNESS (FT)  
 RPD= RETURN PIPE DIAMETER (IN)  
 RPR= RETURN PIPE RADIUS (FT)  
 RSOIL= THERMAL RESISTANCE OF SOIL (HR\*FT\*F/BTU)  
 DELTA= EFFECTIVE PIPE/UTILIDOR DISTANCE (FT)  
 SIR= SUPPLY PIPE RADIUS (FT)  
 SITHK= SUPPLY PIPE INSULATION THICKNESS (IN)  
 SOILC= SOIL CONDUCTIVITY (BTU/HR\*FT\*F)  
 SPD= SUPPLY PIPE DIAMETER (IN)  
 SPR= SUPPLY PIPE RADIUS (FT)  
 TBULK= BULK AIR TEMPERATURE (F)  
 TCNDST= CONDENSATE TEMPERATURE (F)  
 TCONC= INTERIOR CONCRETE TEMPERATURE (F)  
 THCAIR= THERMAL CONDUCTIVITY OF AIR (BTU/HR\*FT\*F)  
 THCC= THERMAL CONDUCTIVITY OF CONCRETE (BTU/HR\*FT\*F)  
 THCSI= THERMAL CONDUCTIVITY OF SUPPLY INSULATION (BTU/HR\*FT\*F)  
 THCRI= THERMAL CONDUCTIVITY OF RETURN INSULATION (BTU/HR\*FT\*F)  
 TINS(S)(R)= INSULATION TEMPERATURE (SUPPLY)(RETURN) (F)  
 TSTEAM= STEAM TEMPERATURE (F)  
 TSURF= GROUND SURFACE TEMPERATURE (F)  
 TX= EXTERIOR CONCRETE TEMPERATURE (F)  
 UTHK= UTILIDOR THICKNESS (FT)  
 VAIR= DYNAMIC VISCOSITY OF AIR (FT\*\*2/SEC)  
 X= UTILIDOR HEIGHT  
 XL= UTILIDOR LENGTH (FT)  
 Y= UTILIDOR WIDTH (FT)

DIMENSION Q(400),QXL(400)  
 CALL CNTRL(3,\*DATAUT\*,5)  
 CALL CNTRL(3,\*TOTALG\*,6)

MULT=MULT+1  
 GO TO 25  
 22 SAVEX=X  
 SAVEY=Y  
 SAVEL=XL  
 MULT=0  
 25 SIR=0  
 RIR=0  
 HLOSSX=0  
 LAST=0

CONVERT UNITS AND DIAMETERS TO RADII  
 SPD=SPD/12  
 RPD=RPD/12  
 SPR=SPD/2  
 RPR=RPD/2  
 IF(KASE) 27,28,26  
 26 RIR=RPR+RITHK  
 27 SIR=SPR+SITHK  
 GO TO 29  
 28 RIR=RPR+RITHK  
 29 RID=RIR\*2.  
 SID=SIR\*2.

GUESS AT CONCRETE AND INSULATION TEMPERATURES  
 TINSS=TSTEAM-100  
 TINSR=TCNDST-100  
 TCONC=55  
 ITNUM=0  
 IF(KASE) 33,44,55  
 33 TINS=TINSS  
 GOTO 60  
 44 TINS=TINSR  
 GOTO 60  
 55 TINS=(TINSS\*SID+TINSR\*RID)/(SID+RID)  
 60 TBULK=(TINS+TCONC)/2.  
 ITNUM=ITNUM+1

CALCULATE THE THERMAL RESISTANCE FOR EACH MAT\*L  
 THCSI=.0221+4.13E-5\*(TSTEAM+TINSS)/2  
 THCRI=.0221+4.13E-5\*(TCNDST+TINSR)/2  
 IF(KASE) 63,64,63  
 63 RINS=ALOG(SIR/SPR)/(2\*PI\*THCSI)  
 IF(KASE) 65,65,64



APPENDIX C: SAMPLE INPUT AND OUTPUT DATA FILES

DATA INPUT FILE

THIS FILE CONTAINS THE VARIABLES REQUIRED OF THE THE HEAT LOSS PROGRAM: "GLOSS". THE FIRST LINE IS THE TOTAL NUMBER OF SECTIONS TO BE EVALUATED. EACH COLUMN, THEREAFTER, CONTAINS VALUES FOR THE VARIABLES BELOW RESPECTIVELY:

- X =UTILIDOR HEIGHT (FT)
- Y =UTILIDOR WIDTH (FT)
- SPD =SUPPLY PIPE DIAMETER (IN)
- SRD =RETURN PIPE DIAMETER (IN)
- L =UTILIDOR LENGTH (FT)

NOTE: ALL COMMENTS MUST BE DELETED BEFORE USING THIS FILE.

229	X	Y	SPD	SRD	L					
1.00	1.00	1.50	1.00	1.00	100.0	4.00	4.00	4.00	2.00	515.0
1.50	1.50	2.00	1.00	1.00	130.0	4.00	4.00	6.00	2.00	410.0
1.50	2.00	2.00	1.00	1.00	140.0	4.00	4.00	6.00	3.00	510.0
2.00	2.00	1.25	1.00	1.00	35.0	4.00	4.00	8.00	2.00	100.0
2.00	2.00	2.00	2.00	2.00	1280.0	4.00	5.00	1.00	1.00	120.0
2.00	2.00	2.50	2.00	2.00	195.0	4.00	5.00	2.00	0.00	130.0
2.00	2.00	3.00	1.25	1.00	100.0	4.00	5.00	0.00	2.00	290.0
2.00	2.00	3.00	1.50	1.50	150.0	4.00	5.00	3.00	1.50	100.0
2.00	2.00	4.00	2.00	1.70	170.0	4.00	5.00	4.00	2.00	260.0
2.00	2.00	5.00	1.50	60.0	60.0	4.00	5.00	4.00	2.50	240.0
2.00	2.00	6.00	6.00	35.0	35.0	0.00	0.00	0.00	6.00	0.0
2.00	1.50	10.00	1.00	30.0	30.0	4.00	5.00	5.00	3.50	400.0
2.00	2.50	2.00	1.00	325.0	325.0	4.00	5.00	6.00	2.50	40.0
2.00	2.50	2.00	2.00	275.0	275.0	4.00	5.00	6.00	3.50	370.0
2.00	2.50	2.00	2.50	620.0	620.0	4.00	5.00	6.00	4.00	270.0
2.00	3.00	6.00	2.50	620.0	620.0	4.00	5.00	6.00	0.00	200.0
2.00	4.00	2.00	1.50	120.0	120.0	4.00	5.00	8.00	3.00	730.0
2.00	4.00	3.00	2.00	275.0	275.0	4.00	5.00	8.00	4.00	1015.0
2.42	2.42	2.50	1.00	190.0	190.0	4.00	5.00	10.00	4.00	180.0
2.50	2.00	2.00	2.00	150.0	150.0	4.00	5.00	10.00	6.00	1200.0
2.50	2.00	6.00	2.50	25.0	25.0	4.50	5.00	6.00	2.00	190.0
2.50	2.00	6.00	0.00	30.0	30.0	4.50	5.00	3.00	1.00	320.0
2.50	3.00	6.00	2.00	65.0	65.0	4.50	5.00	3.00	2.00	190.0
2.50	3.00	8.00	4.00	225.0	225.0	4.50	5.00	3.50	2.00	145.0
2.50	3.50	4.00	2.00	190.0	190.0	0.00	0.00	0.00	1.20	0.0
2.50	2.00	8.00	2.00	30.0	30.0	4.50	5.00	5.00	2.00	230.0
3.00	2.00	8.00	2.00	415.0	415.0	4.50	5.00	5.00	3.00	555.0
3.00	2.50	3.00	1.50	60.0	60.0	4.50	5.00	10.00	4.00	365.0
3.00	2.75	3.00	1.00	100.0	100.0	4.50	4.50	4.00	2.00	770.0
3.00	2.75	4.00	2.00	510.0	510.0	4.50	4.50	6.00	2.00	240.0
3.00	3.00	1.00	1.00	70.0	70.0	4.50	4.50	8.00	4.00	960.0
3.00	3.00	1.50	1.50	50.0	50.0	4.50	4.50	10.00	4.00	170.0
3.00	3.00	2.00	1.50	80.0	80.0	4.50	4.50	12.00	6.00	825.0
3.00	3.00	2.00	1.25	55.0	55.0	5.00	4.00	8.00	4.00	460.0
3.00	3.00	2.50	2.00	50.0	50.0	5.00	4.75	12.00	8.00	450.0
3.00	3.00	2.50	1.00	75.0	75.0	5.00	5.00	1.00	1.00	130.0
3.00	3.00	2.50	1.50	230.0	230.0	5.00	5.00	1.00	1.00	410.0
3.00	3.00	3.00	1.50	635.0	635.0	0.00	0.00	8.00	4.00	0.0
3.00	3.00	3.00	2.00	575.0	575.0	5.00	5.00	1.25	1.25	425.0
3.00	3.00	4.00	2.00	395.0	395.0	5.00	5.00	1.50	1.25	170.0
3.00	3.00	6.00	2.00	305.0	305.0	0.00	0.00	6.00	3.00	0.0
3.00	3.00	8.00	3.00	670.0	670.0	5.00	5.00	2.00	1.00	400.0
3.00	3.00	8.00	4.00	620.0	620.0	5.00	5.00	2.00	2.00	310.0
3.00	3.00	8.00	4.00	210.0	210.0	5.00	5.00	3.00	1.25	190.0
3.00	0.00	6.00	0.00	0.0	0.0	5.00	5.00	3.00	1.50	125.0
3.00	3.50	1.25	1.25	30.0	30.0	5.00	5.00	3.00	2.00	300.0
3.00	3.50	1.50	1.50	60.0	60.0	5.00	5.00	4.00	1.50	155.0
3.00	3.50	2.00	1.00	260.0	260.0	5.00	5.00	4.00	2.00	2315.0
3.00	3.50	2.00	1.50	805.0	805.0	5.00	5.00	4.00	2.00	400.0
3.00	3.50	2.00	2.00	60.0	60.0	5.00	5.00	2.00	0.00	0.0
3.00	3.50	2.50	1.50	965.0	965.0	5.00	5.00	6.00	2.50	1115.0
3.00	3.50	3.00	1.25	330.0	330.0	5.00	5.00	6.00	3.25	355.0
3.00	3.50	3.00	1.50	935.0	935.0	5.00	5.00	2.00	1.25	0.0
3.00	3.50	3.00	2.00	675.0	675.0	5.00	5.00	6.00	3.00	500.0
3.00	3.50	3.50	2.00	675.0	675.0	5.00	5.00	6.00	4.00	120.0
3.00	3.50	4.00	2.50	60.0	60.0	5.00	5.00	2.50	1.25	2800.0
3.00	3.50	5.00	2.00	525.0	525.0	5.00	5.00	8.00	0.00	0.0
3.00	3.50	6.00	3.00	650.0	650.0	5.00	5.00	8.00	3.00	410.0
3.00	3.50	8.00	4.00	700.0	700.0	0.00	0.00	1.50	1.50	0.0
3.00	4.00	2.00	1.00	40.0	40.0	0.00	0.00	0.00	1.25	0.0
3.00	4.00	3.00	2.00	270.0	270.0	5.00	5.00	8.00	4.00	6285.0
3.00	4.00	4.00	3.00	465.0	465.0	5.00	5.00	8.00	4.00	400.0
3.00	4.00	6.00	3.00	50.0	50.0	0.00	0.00	0.00	3.00	0.0
3.00	5.00	2.00	2.00	65.0	65.0	0.00	0.00	0.00	1.50	0.0
3.00	3.00	2.50	1.00	160.0	160.0	5.00	5.00	8.00	6.00	840.0
3.00	3.00	4.00	2.00	150.0	150.0	5.00	5.00	10.00	4.00	4785.0
3.00	3.00	6.00	2.50	150.0	150.0	5.00	5.00	10.00	3.00	420.0
3.00	3.00	6.00	3.00	520.0	520.0	0.00	0.00	4.00	0.00	0.0
3.00	3.50	1.50	1.50	70.0	70.0	5.00	5.00	10.00	5.00	180.0
3.00	3.50	6.00	3.00	420.0	420.0	0.00	0.00	4.00	0.00	0.0
3.00	3.50	8.00	4.00	50.0	50.0	5.00	5.00	10.00	6.00	6605.0
3.00	4.00	6.00	4.00	520.0	520.0	5.00	5.00	12.00	5.00	240.0
3.00	3.00	3.00	2.00	300.0	300.0	5.00	5.00	12.00	6.00	3020.0
3.00	3.00	3.50	2.50	345.0	345.0	5.00	5.00	12.00	8.00	875.0
4.00	4.00	3.00	2.00	90.0	90.0	5.00	5.00	16.00	8.00	750.0
4.00	4.00	3.00	2.00	90.0	90.0	5.33	6.00	1.50	1.25	130.0

0.00	0.00	6.00	3.00	0.00
5.50	4.50	6.00	2.00	1150.00
5.50	5.00	4.00	2.00	120.00
5.50	5.50	8.00	3.00	1285.00
5.50	5.50	10.00	3.00	345.00
5.50	5.50	10.00	4.00	410.00
5.50	5.50	10.00	6.00	1545.00
6.00	4.00	14.00	8.00	415.00
6.00	5.00	10.00	4.00	390.00
6.00	6.00	10.00	6.00	390.00
0.00	0.00	4.00	0.00	0.00
6.00	6.00	10.00	6.00	1060.00
6.00	6.00	14.00	8.00	250.00
6.00	6.00	16.00	10.00	1040.00
6.00	6.30	14.00	8.00	365.00
6.00	6.50	16.00	8.00	105.00
6.00	6.50	20.00	10.00	1550.00
6.00	7.00	1.50	1.00	705.00
6.00	7.00	5.00	2.50	1010.00
6.00	7.00	2.50	2.00	200.00
0.00	0.00	5.00	2.50	0.00
6.00	7.00	6.00	2.50	330.00
6.00	7.00	3.00	1.25	300.00
0.00	0.00	6.00	0.00	0.00
6.00	7.00	6.00	4.00	200.00
6.00	7.00	8.00	4.00	1870.00
6.00	7.00	8.00	6.00	370.00
0.00	0.00	0.00	1.25	0.00
6.00	7.17	3.50	1.00	300.00
0.00	0.00	2.00	0.00	0.00
0.00	0.00	1.00	0.00	0.00
6.00	7.17	12.00	6.00	300.00
6.00	7.17	12.00	8.00	2110.00
6.00	7.50	16.00	10.00	240.00
0.00	0.00	4.00	0.00	0.00
6.00	7.50	18.00	10.00	450.00
0.00	0.00	4.00	0.00	0.00
6.00	7.50	18.00	10.00	100.00
0.00	0.00	4.00	0.00	0.00

6.00	7.50	24.00	10.00	190.00
6.00	8.00	8.00	3.00	400.00
6.50	5.50	10.00	6.00	100.00
7.00	7.00	12.00	6.00	880.00
7.00	7.00	12.00	8.00	2605.00
7.00	7.00	16.00	8.00	3915.00
7.00	7.00	18.00	8.00	1830.00
7.00	7.50	24.00	10.00	210.00
0.00	0.00	4.00	0.00	0.00
7.00	7.50	24.00	12.00	180.00
7.00	9.00	1.50	5.00	50.00
7.00	9.00	2.00	2.00	250.00
7.00	9.00	3.00	1.50	40.00
7.00	9.00	5.00	2.00	40.00
7.00	9.00	5.00	1.50	90.00
7.00	9.00	12.00	5.00	130.00
0.00	0.00	5.00	0.00	0.00
7.00	9.00	14.00	5.00	50.00
0.00	0.00	5.00	0.00	0.00
7.00	9.00	2.50	1.25	40.00
0.00	0.00	8.00	0.00	0.00
7.00	9.00	10.00	2.00	100.00
7.00	9.00	10.00	6.00	290.00
0.00	0.00	10.00	5.00	0.00
7.00	9.00	10.00	6.00	320.00
0.00	0.00	12.00	5.00	0.00
0.00	0.00	3.00	0.00	0.00
7.00	9.00	10.00	6.00	290.00
0.00	0.00	14.00	5.00	0.00
0.00	0.00	3.00	0.00	0.00
7.00	9.00	10.00	5.00	80.00
0.00	0.00	14.00	6.00	0.00
7.00	9.00	12.00	5.00	90.00
7.00	9.00	12.00	5.00	280.00
0.00	0.00	5.00	0.00	0.00
7.00	9.00	8.00	1.50	40.00
7.00	9.00	10.00	5.00	90.00
7.50	6.00	20.00	10.00	450.00

DATA OUTPUT

THIS PROGRAM CALCULATES THE HEAT LOSS FROM UTILIDOR SECTIONS WITH THE VARIABLES BELOW.

INDEPENDENT: X =UTILIDOR HEIGHT (FT)  
 Y =UTILIDOR WIDTH (FT)  
 L =UTILIDOR LENGTH (FT)  
 SPD =SUPPLY PIPE DIAMETER (IN)  
 RPD =RETURN PIPE DIAMETER (IN)  
 TCNDT=RETURN CONDENSATE TEMPERATURE  
 TSTEM=SUPPLY STEAM TEMPERATURE  
 TSURF=GROUND SURFACE TEMPERATURE

DEPENDENT: TBULK=BULK AIR TEMPERATURE  
 TCONC=INTERIOR CONCRETE TEMPERATURE  
 TCONX=EXTERIOR CONCRETE TEMPERATURE  
 TINSS=SUPPLY INSULATION TEMPERATURE  
 TINSR=RETURN INSULATION TEMPERATURE

X (FT)	Y (FT)	SPD (IN)	RPD (IN)	TSURF (F)	TSTEM (F)	TCNDT (F)	TINSS (F)	TINSR (F)	TBULK (F)	TCONC (F)	TCONX (F)	HEAT LOSS (BTU/HR*FT)	L (FT)	HEAT LOSS (BTU/HR)
1.00	1.00	1.50	1.00	25.7	375.0	190.0	156.8	92.0	94.0	61.2	50.4	69.18	100.0	0.69180E 04
1.50	1.50	0.00	1.00	25.7	375.0	190.0	275.0	66.8	50.2	33.6	31.6	19.30	130.0	0.25093E 04
1.50	2.00	2.00	0.00	25.7	375.0	190.0	139.0	90.0	95.9	52.8	46.6	69.99	140.0	0.97982E 04
2.00	2.00	1.25	1.00	25.7	375.0	190.0	130.1	78.1	77.6	50.1	44.6	70.09	35.0	0.24531E 04
2.00	2.00	2.00	2.00	25.7	375.0	190.0	151.4	92.3	89.7	57.6	50.4	91.56	1280.0	0.11720E 06
2.00	2.00	2.50	2.00	25.7	375.0	190.0	160.9	94.5	95.1	60.5	52.7	100.13	195.0	0.19525E 05
2.00	2.00	3.00	1.25	25.7	375.0	190.0	166.3	89.7	99.0	61.8	53.7	103.82	100.0	0.10382E 05
2.00	2.00	3.00	1.50	25.7	375.0	190.0	167.2	92.2	99.4	62.4	54.1	105.35	150.0	0.15803E 05
2.00	2.00	4.00	2.00	25.7	375.0	190.0	182.4	100.7	109.1	68.5	58.9	123.07	170.0	0.20922E 05
2.00	2.00	5.00	1.50	25.7	375.0	190.0	191.3	100.6	116.8	72.5	62.0	134.57	60.0	0.80742E 04
2.00	2.00	6.00	6.00	25.7	375.0	190.0	241.0	137.1	146.4	93.2	78.1	194.03	35.0	0.67911E 04
2.00	1.50	2.00	1.00	25.7	375.0	190.0	151.0	83.8	89.2	56.3	48.8	83.79	30.0	0.25138E 04
2.00	2.50	2.00	1.00	25.7	375.0	190.0	145.2	80.5	85.9	54.4	48.4	85.75	325.0	0.27869E 05
2.00	2.50	2.00	2.00	25.7	375.0	190.0	148.5	90.8	88.2	56.7	50.3	92.66	275.0	0.25483E 05
2.00	2.50	6.00	2.50	25.7	375.0	190.0	200.8	109.6	122.5	77.1	66.4	153.63	620.0	0.95251E 05
2.00	3.00	6.00	2.50	25.7	375.0	190.0	198.4	107.8	121.0	76.2	66.4	155.72	620.0	0.96546E 05
2.00	4.00	2.00	1.50	25.7	375.0	190.0	140.5	82.8	83.7	53.9	49.1	91.66	120.0	0.10999E 05
2.00	4.00	3.00	2.00	25.7	375.0	190.0	159.3	91.3	94.8	60.4	54.6	112.86	275.0	0.31036E 05
2.42	2.42	2.50	1.00	25.7	375.0	190.0	152.0	80.9	89.6	55.7	49.5	95.90	190.0	0.18221E 05
2.50	2.00	2.00	2.00	25.7	375.0	190.0	147.4	89.7	87.0	55.3	48.9	93.19	150.0	0.13979E 05
2.50	2.00	6.00	2.50	25.7	375.0	190.0	199.4	108.0	120.7	75.0	64.2	155.01	25.0	0.38752E 04
2.50	2.00	6.00	0.00	25.7	375.0	190.0	184.5	90.0	127.4	70.2	60.5	139.99	30.0	0.41996E 04
2.50	2.50	2.00	2.00	25.7	375.0	190.0	144.8	88.4	85.6	54.6	48.7	94.16	65.0	0.61204E 04
2.50	3.00	6.00	4.00	25.7	375.0	190.0	198.6	112.6	118.2	74.8	65.4	164.82	225.0	0.37085E 05
2.50	3.00	8.00	4.00	25.7	375.0	190.0	212.9	117.9	129.5	81.7	71.0	188.01	190.0	0.35722E 05
2.50	3.50	4.00	2.00	25.7	375.0	190.0	171.4	93.5	101.8	63.3	56.6	129.78	30.0	0.38934E 04
3.00	2.00	8.00	2.00	25.7	375.0	190.0	208.6	107.7	129.4	78.9	67.6	181.04	415.0	0.75132E 05
3.00	2.50	3.00	1.50	25.7	375.0	190.0	157.6	85.6	92.5	57.0	50.7	110.03	60.0	0.66602E 04
3.00	2.75	3.00	1.00	25.7	375.0	190.0	155.1	79.6	91.2	55.6	49.8	106.86	100.0	0.10686E 05
3.00	2.75	4.00	2.00	25.7	375.0	190.0	171.3	92.8	101.0	62.1	55.1	129.99	510.0	0.66293E 05
3.00	3.00	1.00	1.00	25.7	375.0	190.0	112.8	70.8	68.0	44.2	40.7	66.99	70.0	0.46892E 04
3.00	3.00	1.50	1.50	25.7	375.0	190.0	127.4	78.7	75.8	48.5	44.2	82.44	50.0	0.41219E 04
3.00	3.00	2.00	1.50	25.7	375.0	190.0	138.4	80.7	81.4	51.3	46.5	92.59	80.0	0.74074E 04
3.00	3.00	2.00	1.25	25.7	375.0	190.0	137.7	78.1	80.9	50.8	46.0	90.66	55.0	0.49863E 04
3.00	3.00	2.00	2.00	25.7	375.0	190.0	139.6	85.3	82.4	52.3	47.3	96.20	550.0	0.52908E 05
3.00	3.00	2.50	1.00	25.7	375.0	190.0	146.2	77.2	85.7	52.8	47.7	98.21	75.0	0.73658E 04
3.00	3.00	2.50	1.50	25.7	375.0	190.0	147.6	82.6	86.5	53.9	48.6	102.04	230.0	0.23470E 05
3.00	3.00	3.00	1.50	25.7	375.0	190.0	155.6	84.4	91.3	56.4	50.6	110.95	635.0	0.70455E 05
3.00	3.00	3.00	2.00	25.7	375.0	190.0	156.9	88.9	92.0	57.3	51.3	114.28	575.0	0.65713E 05
3.00	3.00	4.00	2.00	25.7	375.0	190.0	170.3	92.2	100.4	61.8	55.0	130.58	395.0	0.51577E 05

X (FT)	Y (FT)	SPD (IN)	RPD (IN)	TSURF (F)	TSTEM (F)	TCNDT (F)	TINSS (F)	TINSR (F)	TBLUK (F)	TCONC (F)	TCONX (F)	HEAT LOSS (BTU/HR*FT)	L (FT)	HEAT LOSS (BTU/HR)
3.00	3.00	6.00	2.00	25.7	375.0	190.0	190.3	98.5	114.7	69.8	61.5	159.51	305.0	0.48650E 05
3.00	3.00	6.00	3.00	25.7	375.0	190.0	192.8	104.9	115.0	71.1	62.5	164.13	670.0	0.10997E 06
3.00	3.00	8.00	2.00	25.7	375.0	190.0	204.8	104.3	126.5	76.9	67.2	185.12	620.0	0.11478E 06
3.00	3.00	8.00	4.00	25.7	375.0	190.0	209.6	115.0	126.5	78.8	68.8	192.14	210.0	0.40349E 05
0.00	0.00	6.00	0.00	25.7	375.0	190.0	178.8	90.0	122.1	65.4	57.9	143.70	0.0	0.30177E 05
3.00	3.50	1.25	1.25	25.7	375.0	190.0	118.8	74.1	71.3	46.0	42.4	75.40	330.0	0.24882E 05
3.00	3.50	1.50	1.50	25.7	375.0	190.0	125.7	77.8	74.9	48.1	44.1	82.95	60.0	0.49769E 04
3.00	3.50	2.00	1.00	25.7	375.0	190.0	135.3	74.3	79.4	49.8	45.5	89.17	260.0	0.23184E 05
3.00	3.50	2.00	1.50	25.7	375.0	190.0	136.6	79.8	80.5	50.8	46.4	93.21	805.0	0.75034E 05
3.00	3.50	2.00	2.00	25.7	375.0	190.0	137.8	84.4	81.5	51.8	47.2	96.87	60.0	0.58124E 04
3.00	3.50	2.50	1.50	25.7	375.0	190.0	145.8	81.6	85.6	53.4	48.5	102.77	965.0	0.99169E 05
3.00	3.50	3.00	1.25	25.7	375.0	190.0	153.1	80.9	90.0	55.4	50.1	109.95	330.0	0.36284E 05
3.00	3.50	3.00	1.50	25.7	375.0	190.0	153.8	83.5	90.3	55.8	50.5	111.77	935.0	0.10451E 06
3.00	3.50	3.00	2.00	25.7	375.0	190.0	155.1	87.9	91.0	56.8	51.2	115.17	675.0	0.77741E 05
3.00	3.50	3.50	2.00	25.7	375.0	190.0	162.1	89.5	95.3	59.0	53.1	123.61	75.0	0.92704E 04
3.00	3.50	4.00	2.00	25.7	375.0	190.0	168.4	91.2	99.4	61.2	54.9	131.66	6360.0	0.83736E 06
3.00	3.50	5.00	2.50	25.7	375.0	190.0	180.6	97.8	107.1	66.0	58.8	149.52	45.0	0.67282E 04
3.00	3.50	6.00	2.00	25.7	375.0	190.0	188.5	97.3	113.6	69.1	61.4	160.94	525.0	0.84492E 05
3.00	3.50	6.00	3.00	25.7	375.0	190.0	190.9	103.7	113.9	70.4	62.4	165.74	650.0	0.10773E 06
3.00	3.50	8.00	4.00	25.7	375.0	190.0	207.7	113.7	125.3	78.1	68.8	194.28	700.0	0.13600E 06
3.00	4.00	2.00	1.00	25.7	375.0	190.0	133.7	73.5	78.6	49.4	45.4	89.67	40.0	0.35870E 04
3.00	4.00	3.00	2.00	25.7	375.0	190.0	153.4	87.0	90.1	56.3	51.1	115.98	270.0	0.31313E 05
3.00	4.00	4.00	3.00	25.7	375.0	190.0	169.1	97.1	99.3	62.2	56.1	138.40	465.0	0.64357E 05
3.00	4.00	6.00	3.00	25.7	375.0	190.0	189.2	102.7	112.9	69.8	62.4	167.19	50.0	0.83597E 04
3.00	5.00	2.00	2.00	25.7	375.0	190.0	133.2	82.1	79.2	50.8	46.9	98.55	65.0	0.64058E 04
3.50	3.00	2.50	1.00	25.7	375.0	190.0	143.6	75.4	83.9	51.4	46.6	99.22	160.0	0.15876E 05
3.50	3.00	4.00	2.00	25.7	375.0	190.0	167.5	90.2	98.3	59.9	53.6	132.32	150.0	0.19847E 05
3.50	3.00	6.00	2.50	25.7	375.0	190.0	188.7	99.6	112.4	68.3	60.3	164.41	150.0	0.24662E 05
3.50	3.00	6.00	3.00	25.7	375.0	190.0	189.9	102.6	112.6	68.9	60.8	166.76	520.0	0.86717E 05
3.50	3.50	1.50	1.50	25.7	375.0	190.0	123.5	76.3	73.4	46.9	43.1	83.69	70.0	0.58582E 04
3.50	3.50	6.00	3.00	25.7	375.0	190.0	188.1	101.5	111.5	68.2	60.7	168.25	420.0	0.70667E 05
3.50	3.50	8.00	4.00	25.7	375.0	190.0	204.9	111.3	122.8	75.7	66.9	197.73	50.0	0.98867E 04
3.50	4.50	6.00	4.00	25.7	375.0	190.0	187.0	104.8	110.1	68.4	61.6	175.61	520.0	0.91315E 05
4.00	3.00	3.00	2.00	25.7	375.0	190.0	151.7	85.3	88.2	54.2	49.0	116.93	500.0	0.58466E 05
4.00	3.00	3.50	2.50	25.7	375.0	190.0	159.9	90.6	92.9	57.1	51.4	128.76	345.0	0.44423E 05
4.00	4.00	3.00	2.00	25.7	375.0	190.0	148.6	83.7	86.6	53.4	48.8	118.39	90.0	0.10655E 05
4.00	4.00	4.00	2.00	25.7	375.0	190.0	161.9	86.6	94.6	57.4	52.1	135.66	515.0	0.69866E 05
4.00	4.00	6.00	2.00	25.7	375.0	190.0	182.0	92.1	108.3	64.6	58.1	166.42	410.0	0.68232E 05
4.00	4.00	6.00	3.00	25.7	375.0	190.0	184.1	98.6	108.6	65.9	59.2	171.81	510.0	0.87621E 05
4.00	4.00	8.00	2.00	25.7	375.0	190.0	196.8	97.3	119.7	71.0	63.4	193.67	100.0	0.19367E 05
4.00	5.00	1.00	1.00	25.7	375.0	190.0	104.0	65.9	63.1	41.3	38.9	69.03	120.0	0.82834E 04
4.00	5.00	2.00	0.00	25.7	375.0	190.0	118.5	90.0	80.6	42.7	40.1	75.09	130.0	0.97613E 04
4.00	5.00	0.00	2.00	25.7	375.0	190.0	275.0	68.1	50.3	32.6	31.5	30.31	290.0	0.87909E 04
4.00	5.00	3.00	1.50	25.7	375.0	190.0	144.9	78.0	84.6	51.9	47.9	115.89	100.0	0.11589E 05
4.00	5.00	4.00	2.00	25.7	375.0	190.0	159.2	85.2	93.2	56.7	52.0	137.19	260.0	0.35669E 05
4.00	5.00	4.00	2.50	25.7	375.0	190.0	160.2	88.8	93.6	57.5	52.6	140.46	240.0	0.33710E 05
0.00	0.00	0.00	6.00	25.7	375.0	190.0	275.0	91.0	65.2	39.4	37.3	60.34	0.0	0.14483E 05
4.00	5.00	5.00	3.50	25.7	375.0	190.0	173.1	97.4	101.1	62.4	56.7	162.09	400.0	0.64836E 05
4.00	5.00	6.00	2.50	25.7	375.0	190.0	180.4	94.0	106.9	64.5	58.5	171.35	40.0	0.68540E 04
4.00	5.00	6.00	3.50	25.7	375.0	190.0	182.3	99.8	107.2	65.7	59.5	176.63	370.0	0.65354E 05
4.00	5.00	6.00	4.00	25.7	375.0	190.0	183.2	102.2	107.4	66.2	60.0	179.08	270.0	0.48351E 05
4.00	5.00	6.00	0.00	25.7	375.0	190.0	169.6	90.0	114.6	59.5	54.3	149.56	200.0	0.29912E 05
4.00	5.00	8.00	3.00	25.7	375.0	190.0	196.3	101.7	118.0	71.2	64.2	201.08	730.0	0.14679E 06
4.00	5.00	8.00	4.00	25.7	375.0	190.0	198.1	106.6	118.0	72.2	65.0	205.47	1015.0	0.20856E 06
4.00	5.00	10.00	4.00	25.7	375.0	190.0	209.8	116.6	127.2	77.6	69.6	229.37	180.0	0.41286E 05
4.00	5.00	10.00	6.00	25.7	375.0	190.0	213.0	117.8	127.0	79.1	70.9	235.97	1200.0	0.28316E 06
4.50	4.00	6.00	2.00	25.7	375.0	190.0	179.8	90.4	106.5	63.0	56.9	168.22	190.0	0.31961E 05

X (FT)	Y (FT)	SPD (IN)	RPD (IN)	TSURF (F)	TSTEM (F)	TCNDT (F)	TINSS (F)	TINSR (F)	TBULK (F)	TCONC (F)	TCONX (F)	HEAT LOSS (BTU/HR*FT)	L (FT)	HEAT LOSS (BTU/HR)
4.50	5.00	3.00	1.00	25.7	375.0	190.0	141.9	71.6	82.7	49.9	46.2	112.60	320.0	0.36032E 05
4.50	5.00	3.00	2.00	25.7	375.0	190.0	144.1	81.0	83.8	51.6	47.6	120.59	190.0	0.22912E 05
4.50	5.00	3.50	2.00	25.7	375.0	190.0	151.0	82.4	87.8	53.6	49.3	129.69	145.0	0.18805E 05
0.00	0.00	0.00	1.20	25.7	375.0	190.0	275.0	59.8	45.2	30.6	29.8	22.74	0.0	0.32974E 04
4.50	5.00	5.00	2.00	25.7	375.0	190.0	168.1	86.4	98.7	59.0	53.9	154.84	230.0	0.35612E 05
4.50	5.00	5.00	3.00	25.7	375.0	190.0	170.1	93.1	99.1	60.3	55.0	160.98	555.0	0.89342E 05
4.50	5.00	10.00	4.00	25.7	375.0	190.0	207.7	108.7	125.2	75.6	68.0	232.40	365.0	0.84824E 05
4.50	4.50	4.00	2.00	25.7	375.0	190.0	158.5	84.4	92.3	55.8	51.0	137.70	770.0	0.10603E 06
4.50	4.50	6.00	2.00	25.7	375.0	190.0	178.5	89.6	105.8	62.6	56.8	169.22	240.0	0.40613E 05
4.50	4.50	8.00	4.00	25.7	375.0	190.0	197.2	105.6	116.8	70.8	63.6	206.67	960.0	0.19840E 06
4.50	4.50	10.00	4.00	25.7	375.0	190.0	208.8	109.5	125.9	76.1	68.1	230.84	170.0	0.39242E 05
4.50	4.50	12.00	6.00	25.7	375.0	190.0	221.4	120.2	133.4	82.2	73.2	258.87	825.0	0.21357E 06
5.00	4.00	8.00	4.00	25.7	375.0	190.0	196.4	104.7	115.8	69.6	62.4	207.69	460.0	0.95537E 05
5.00	4.75	12.00	8.00	25.7	375.0	190.0	221.6	123.3	130.9	81.2	72.6	268.86	450.0	0.12099E 06
5.00	5.00	1.00	1.00	25.7	375.0	190.0	101.2	64.1	61.3	40.0	37.8	69.70	130.0	0.90606E 04
5.00	5.00	1.00	1.00	25.7	375.0	190.0	101.2	64.1	61.3	40.0	37.8	69.70	410.0	0.28576E 05
0.00	0.00	8.00	4.00	25.7	375.0	190.0	194.0	103.2	114.4	68.8	62.2	210.37	0.0	0.86252E 05
5.00	5.00	1.25	1.25	25.7	375.0	190.0	108.2	67.8	64.9	41.8	39.3	78.32	425.0	0.33287E 05
5.00	5.00	1.50	1.25	25.7	375.0	190.0	114.1	68.6	67.6	43.0	40.3	84.22	170.0	0.14317E 05
0.00	0.00	6.00	3.00	25.7	375.0	190.0	177.3	93.9	103.7	62.1	56.6	177.67	0.0	0.30203E 05
5.00	5.00	2.00	1.00	25.7	375.0	190.0	123.8	67.4	72.2	44.8	41.9	93.01	400.0	0.37205E 05
5.00	5.00	2.00	2.00	25.7	375.0	190.0	125.7	77.1	74.0	46.5	43.3	101.38	310.0	0.31489E 05
5.00	5.00	3.00	1.25	25.7	375.0	190.0	140.8	73.1	81.7	49.4	45.8	115.52	190.0	0.21949E 05
5.00	5.00	3.00	1.50	25.7	375.0	190.0	141.3	75.5	82.0	49.8	46.1	117.59	125.0	0.14699E 05
5.00	5.00	3.00	2.00	25.7	375.0	190.0	142.3	79.8	82.6	50.6	46.8	121.47	300.0	0.36441E 05
5.00	5.00	4.00	1.50	25.7	375.0	190.0	154.4	78.3	89.9	53.5	49.3	135.83	155.0	0.21054E 05
5.00	5.00	4.00	2.00	25.7	375.0	190.0	155.4	82.5	90.3	54.3	49.9	139.51	2315.0	0.32295E 06
5.00	5.00	4.00	2.00	25.7	375.0	190.0	155.4	82.5	90.3	54.3	49.9	139.51	400.0	0.55802E 05
0.00	0.00	2.00	0.00	25.7	375.0	190.0	115.7	90.0	78.5	41.2	38.9	75.77	0.0	0.30308E 05
5.00	5.00	6.00	2.50	25.7	375.0	190.0	176.4	90.9	103.6	61.5	56.1	174.78	1115.0	0.19488E 06
5.00	5.00	6.00	3.25	25.7	375.0	190.0	177.8	95.3	103.8	62.4	56.8	179.05	355.0	0.63563E 05
0.00	0.00	2.00	1.25	25.7	375.0	190.0	124.3	70.1	72.6	45.2	42.3	95.31	0.0	0.33836E 05
5.00	5.00	6.00	3.00	25.7	375.0	190.0	177.3	93.9	103.7	62.1	56.6	177.67	500.0	0.88833E 05
5.00	5.00	6.00	4.00	25.7	375.0	190.0	179.1	99.2	104.0	63.2	57.5	183.01	120.0	0.21962E 05
5.00	5.00	2.50	1.25	25.7	375.0	190.0	133.1	71.6	77.3	47.4	44.1	105.69	2800.0	0.29595E 06
0.00	0.00	8.00	0.00	25.7	375.0	190.0	181.9	90.0	122.5	63.2	57.4	182.71	0.0	0.51157E 06
5.00	5.00	8.00	3.00	25.7	375.0	190.0	192.3	98.2	114.4	67.8	61.4	205.61	410.0	0.84301E 05
0.00	0.00	1.50	1.50	25.7	375.0	190.0	114.5	71.1	68.1	43.4	40.7	86.45	0.0	0.35446E 05
0.00	0.00	0.00	1.25	25.7	375.0	190.0	275.0	59.8	45.1	30.5	29.8	23.34	0.0	0.35685E 04
5.00	5.00	8.00	4.00	25.7	375.0	190.0	194.0	103.2	114.4	68.8	62.2	210.37	6285.0	0.13222E 07
5.00	5.00	8.00	4.00	25.7	375.0	190.0	194.0	103.2	114.4	68.8	62.2	210.37	400.0	0.84149E 05
0.00	0.00	0.00	3.00	25.7	375.0	190.0	275.0	74.2	54.0	33.7	32.5	39.23	0.0	0.15694E 05
0.90	0.00	0.00	1.50	25.7	375.0	190.0	275.0	62.4	46.7	31.0	30.2	25.85	0.0	0.10341E 05
5.00	5.00	8.00	6.00	25.7	375.0	190.0	197.1	111.0	114.7	70.5	63.7	218.74	840.0	0.18374E 06
5.00	5.00	10.00	4.00	25.7	375.0	190.0	205.7	107.0	123.4	73.9	66.6	235.18	4785.0	0.11253E 07
5.00	5.00	10.00	3.00	25.7	375.0	190.0	204.1	102.3	123.6	73.0	65.8	230.96	420.0	0.97002E 05
0.00	0.00	4.00	0.00	25.7	375.0	190.0	145.4	90.0	97.5	49.7	46.0	116.84	0.0	0.49073E 05
5.00	5.00	10.00	5.00	25.7	375.0	190.0	207.3	111.0	123.3	74.7	67.2	239.01	180.0	0.43022E 05
0.00	0.00	4.00	0.00	25.7	375.0	190.0	145.4	90.0	97.5	49.7	46.0	116.84	0.0	0.21031E 05
5.00	5.00	10.00	6.00	25.7	375.0	190.0	208.7	114.4	123.2	75.4	67.8	242.54	6605.0	0.16019E 07
5.00	5.00	12.00	5.00	25.7	375.0	190.0	216.8	114.4	131.0	79.3	71.1	261.38	240.0	0.62730E 05
5.00	5.00	12.00	6.00	25.7	375.0	190.0	218.2	117.6	130.8	79.9	71.6	264.44	3020.0	0.79862E 06
5.00	5.00	12.00	8.00	25.7	375.0	190.0	221.0	122.9	130.6	81.0	72.6	269.91	875.0	0.23617E 06
5.00	5.00	16.00	8.00	25.7	375.0	190.0	235.5	128.5	143.1	88.8	79.2	307.86	750.0	0.23090E 06
5.33	6.00	1.50	1.25	25.7	375.0	190.0	111.3	67.1	66.1	42.2	39.8	85.00	130.0	0.11050E 05
0.00	0.00	6.00	3.00	25.7	375.0	190.0	174.0	91.9	101.6	60.7	55.7	180.47	0.0	0.23461E 05
5.50	4.50	6.00	2.00	25.7	375.0	190.0	174.8	86.7	102.7	60.0	54.6	172.30	1150.0	0.19814E 06

X (FT)	Y (FT)	SPD (IN)	RPD (IN)	TSURF (F)	TSTEM (F)	TCNDT (F)	TINSS (F)	TINSR (F)	TBULK (F)	TCONC (F)	TCONX (F)	HEAT LOSS (BTU/HR*FT)	L (FT)	HEAT LOSS (BTU/HR)
5.50	5.00	4.00	2.00	25.7	375.0	190.0	153.7	81.3	89.0	53.3	49.1	140.53	120.0	0.16863E 05
5.50	5.50	8.00	3.00	25.7	375.0	190.0	189.4	96.1	112.2	66.1	60.2	208.70	1285.0	0.26818E 06
5.50	5.50	10.00	3.00	25.7	375.0	190.0	201.3	100.0	121.3	71.1	64.5	234.61	345.0	0.80939E 05
5.50	5.50	10.00	4.00	25.7	375.0	190.0	202.9	104.7	121.1	72.0	65.2	239.09	410.0	0.98029E 05
5.50	5.50	10.00	6.00	25.7	375.0	190.0	205.7	112.2	120.9	73.5	66.5	246.97	1545.0	0.38156E 06
6.00	4.00	14.00	8.00	25.7	375.0	190.0	227.4	124.1	135.1	82.5	73.4	292.90	415.0	0.12156E 06
6.00	5.00	10.00	4.00	25.7	375.0	190.0	202.2	103.9	120.2	70.9	64.1	240.14	390.0	0.93655E 05
6.00	6.00	10.00	6.00	25.7	375.0	190.0	203.0	110.3	118.9	71.8	65.3	250.99	390.0	0.97887E 05
0.00	0.00	4.00	0.00	25.7	375.0	190.0	140.8	90.0	94.1	47.5	44.4	118.84	0.0	0.46348E 05
6.00	6.00	10.00	6.00	25.7	375.0	190.0	203.0	110.3	118.9	71.8	65.3	250.99	1060.0	0.26605E 06
6.00	6.00	14.00	8.00	25.7	375.0	190.0	223.2	121.4	132.6	81.0	73.2	301.18	250.0	0.75295E 05
6.00	6.00	16.00	10.00	25.7	375.0	190.0	232.3	128.0	138.0	85.4	76.9	324.97	1040.0	0.33796E 06
6.00	6.50	14.00	8.00	25.7	375.0	190.0	222.3	120.9	132.0	80.7	73.2	302.95	365.0	0.11105E 06
6.00	6.50	16.00	8.00	25.7	375.0	190.0	229.2	123.4	137.9	84.3	76.2	322.52	105.0	0.33865E 06
6.00	6.50	20.00	10.00	25.7	375.0	190.0	242.5	131.9	147.5	91.5	82.4	361.90	1550.0	0.56095E 06
6.00	7.00	1.50	1.00	25.7	375.0	190.0	107.8	62.7	63.8	40.7	38.7	83.45	705.0	0.58832E 05
6.00	7.00	5.00	2.50	25.7	375.0	190.0	159.9	84.1	92.8	55.3	51.3	164.52	1010.0	0.16616E 06
6.00	7.00	2.50	2.00	25.7	375.0	190.0	127.9	74.7	74.6	46.3	43.6	114.63	200.0	0.22925E 05
0.00	0.00	5.00	2.50	25.7	375.0	190.0	159.9	84.1	92.8	55.3	51.3	164.52	0.0	0.32904E 05
6.00	7.00	6.00	2.50	25.7	375.0	190.0	169.1	86.2	98.7	58.2	53.9	180.71	330.0	0.59635E 05
6.00	7.00	3.00	1.25	25.7	375.0	190.0	134.1	69.4	77.8	47.0	44.1	118.42	300.0	0.35526E 05
0.00	0.00	6.00	0.00	25.7	375.0	190.0	159.7	90.0	106.7	53.7	50.0	155.81	0.0	0.46744E 05
6.00	7.00	6.00	4.00	25.7	375.0	190.0	171.5	94.5	99.2	59.8	55.3	189.76	200.0	0.37952E 05
6.00	7.00	8.00	4.00	25.7	375.0	190.0	186.5	98.2	109.2	65.0	59.8	218.70	1870.0	0.40897E 06
6.00	7.00	8.00	6.00	25.7	375.0	190.0	189.2	106.1	109.5	66.7	61.3	228.20	370.0	0.34435E 05
0.00	0.00	0.00	1.25	25.7	375.0	190.0	275.0	57.6	43.8	30.0	29.4	23.69	0.0	0.87640E 04
6.00	7.17	3.50	1.00	25.7	375.0	190.0	140.0	68.1	81.5	48.3	45.3	126.07	300.0	0.37820E 05
0.00	0.00	2.00	0.00	25.7	375.0	190.0	110.0	90.0	74.8	39.5	37.7	77.15	0.0	0.23145E 05
0.00	0.00	1.00	0.00	25.7	375.0	190.0	89.0	90.0	62.0	35.0	33.8	51.83	0.0	0.15548E 05
6.00	7.17	12.00	6.00	25.7	375.0	190.0	210.6	112.0	125.1	75.4	68.8	277.34	300.0	0.83203E 05
6.00	7.17	12.00	8.00	25.7	375.0	190.0	213.0	117.6	124.9	76.6	69.9	284.15	2110.0	0.59955E 06
6.00	7.50	16.00	10.00	25.7	375.0	190.0	229.6	126.4	136.5	84.6	77.0	330.90	240.0	0.79416E 05
0.00	0.00	4.00	0.00	25.7	375.0	190.0	138.5	90.0	92.7	47.0	44.3	119.86	0.0	0.28767E 05
6.00	7.50	18.00	10.00	25.7	375.0	190.0	235.7	128.6	141.7	87.9	79.8	349.02	450.0	0.15706E 06
0.00	0.00	4.00	0.00	25.7	375.0	190.0	138.5	90.0	92.7	47.0	44.3	119.86	0.0	0.53939E 05
6.00	7.50	18.00	10.00	25.7	375.0	190.0	235.7	128.6	141.7	87.9	79.8	349.02	100.0	0.34902E 05
0.00	0.00	4.00	0.00	25.7	375.0	190.0	138.5	90.0	92.7	47.0	44.3	119.86	0.0	0.11986E 05
6.00	7.50	24.00	10.00	25.7	375.0	190.0	249.9	134.8	155.2	96.7	87.4	398.39	190.0	0.75694E 05
6.00	8.00	8.00	3.00	25.7	375.0	190.0	183.4	92.3	108.3	63.6	58.8	215.02	400.0	0.86007E 05
6.50	5.50	10.00	6.00	25.7	375.0	190.0	202.4	109.6	118.0	70.8	64.3	252.08	100.0	0.25208E 05
7.00	7.00	12.00	6.00	25.7	375.0	190.0	207.9	109.7	122.5	72.9	66.6	282.08	880.0	0.24823E 06
7.00	7.00	12.00	8.00	25.7	375.0	190.0	210.2	115.3	122.4	74.1	67.6	289.33	2605.0	0.75370E 06
7.00	7.00	16.00	8.00	25.7	375.0	190.0	225.4	120.2	134.5	81.1	73.7	331.31	3915.0	0.12971E 07
7.00	7.00	18.00	8.00	25.7	375.0	190.0	231.5	122.5	139.8	84.3	76.5	350.52	1830.0	0.64145E 06
7.00	7.50	24.00	10.00	25.7	375.0	190.0	247.2	132.0	152.1	93.3	84.5	408.12	210.0	0.85705E 05
0.00	0.00	4.00	0.00	25.7	375.0	190.0	136.2	90.0	90.9	45.7	43.1	120.84	0.0	0.25377E 05
7.00	7.50	24.00	12.00	25.7	375.0	190.0	248.9	135.0	151.4	93.8	84.9	410.85	180.0	0.73953E 05
7.00	9.00	1.50	5.00	25.7	375.0	190.0	107.6	87.2	69.2	44.6	42.3	117.01	60.0	0.70207E 04
7.00	9.00	2.00	2.00	25.7	375.0	190.0	114.3	70.7	67.7	42.8	40.7	105.84	250.0	0.26459E 05
7.00	9.00	3.00	1.50	25.7	375.0	190.0	129.2	68.9	75.0	45.6	43.2	122.94	40.0	0.49177E 04
7.00	9.00	5.00	2.00	25.7	375.0	190.0	153.3	77.3	89.0	52.3	49.1	164.85	40.0	0.65939E 04
7.00	9.00	5.00	1.50	25.7	375.0	190.0	152.4	73.4	88.9	51.7	48.6	160.90	90.0	0.14481E 05
7.00	9.00	12.00	5.00	25.7	375.0	190.0	203.8	104.5	121.0	71.4	65.9	282.59	130.0	0.36737E 05
0.00	0.00	5.00	0.00	25.7	375.0	190.0	145.0	90.0	96.7	48.5	45.7	141.01	0.0	0.18331E 05
7.00	9.00	14.00	5.00	25.7	375.0	190.0	212.2	107.2	127.7	75.1	69.2	305.74	50.0	0.15287E 05
0.00	0.00	5.00	0.00	25.7	375.0	190.0	145.0	90.0	96.7	48.5	45.7	141.01	0.0	0.70505E 04
7.00	9.00	2.50	1.25	25.7	375.0	190.0	121.4	65.4	70.7	43.5	41.3	110.12	40.0	0.44046E 04



X (FT)	Y (FT)	SPD (IN)	RPD (IN)	TSURF (F)	TSTEM (F)	TCNDT (F)	TINSS (F)	TINSR (F)	TBULK (F)	TCONC (F)	TCONX (F)	HEAT LOSS (BTU/HR*FT)	L (FT)	HEAT LOSS (BTU/HR)	
0.00	0.00	8.00	0.00	25.7	375.0	190.0	170.2	90.0	113.5	56.8	53.0	192.37	0.0	0.76949E 04	
7.00	9.00	10.00	2.00	25.7	375.0	190.0	189.7	86.9	114.4	64.7	60.0	241.51	100.0	0.24151E 05	
7.00	9.00	10.00	6.00	25.7	375.0	190.0	195.0	105.2	113.6	68.1	63.0	262.30	290.0	0.76067E 05	
0.00	0.00	10.00	5.00	25.7	375.0	190.0	193.8	101.6	113.6	67.4	62.3	257.70	0.0	0.74734E 05	
7.00	9.00	10.00	6.00	25.7	375.0	190.0	195.0	105.2	113.6	68.1	63.0	262.30	320.0	0.83936E 05	
0.00	0.00	12.00	5.00	25.7	375.0	190.0	203.8	104.5	121.0	71.4	65.9	282.59	0.0	0.90429E 05	
0.00	0.00	3.00	0.00	25.7	375.0	190.0	121.4	90.0	81.7	42.0	40.0	100.90	0.0	0.32289E 05	
7.00	9.00	10.00	6.00	25.7	375.0	190.0	195.0	105.2	113.6	68.1	63.0	262.30	290.0	0.76067E 05	
0.00	0.00	14.00	5.00	25.7	375.0	190.0	212.2	107.2	127.7	75.1	69.2	305.74	0.0	0.88665E 05	
0.00	0.00	3.00	0.00	25.7	375.0	190.0	121.4	90.0	81.7	42.0	40.0	100.90	0.0	0.29262E 05	
7.00	9.00	10.00	5.00	25.7	375.0	190.0	193.8	101.6	113.6	67.4	62.3	257.70	80.0	0.20616E 05	
0.00	0.00	14.00	6.00	25.7	375.0	190.0	213.3	110.5	127.4	75.7	69.7	309.61	0.0	0.24769E 05	
7.00	9.00	12.00	5.00	25.7	375.0	190.0	203.8	104.5	121.0	71.4	65.9	282.59	90.0	0.25433E 05	
7.00	9.00	12.00	5.00	25.7	375.0	190.0	203.8	104.5	121.0	71.4	65.9	282.59	280.0	0.79126E 05	
0.00	0.00	5.00	0.00	25.7	375.0	190.0	145.0	90.0	96.7	48.5	45.7	141.01	0.0	0.39483E 05	
7.00	9.00	8.00	1.50	25.7	375.0	190.0	176.7	79.7	105.6	59.6	55.5	209.60	40.0	0.83839E 04	
7.00	9.00	10.00	5.00	25.7	375.0	190.0	193.8	101.6	113.6	67.4	62.3	257.70	90.0	0.23193E 05	
0	7.50	6.00	20.00	10.00	25.7	375.0	190.0	239.0	128.4	143.6	87.2	78.6	372.70	450.0	0.16771E 06

TOTAL HEAT LOSS FROM UTILIDORS= 0.2335E 08 BTU/HR  
0.2045E 06 MBTU/YR