

**US Army Corps
of Engineers®**
Cold Regions Research &
Engineering Laboratory

Storage and Preservation of Soil Samples for Volatile Compound Analysis

Alan D. Hewitt

May 1999

Abstract: Traditionally, soil samples obtained for characterizing or monitoring sites for volatile organic compounds (VOCs) have been transported off site before initiating the preparation steps necessary for analysis. In the most recent regulatory guidance, only a two-day holding period at $4 \pm 2^\circ\text{C}$ is recommended before a sample should be preserved, so as to allow storage up to 14 days prior to instrumental analysis. The transportation and storage of soil samples were evaluated for (1) covered core barrel liners, (2) En Core samplers, and (3) empty volatile organic analysis (VOA)

vials under different conditions. Core barrel liners covered with either of two formulations of Teflon sheeting or aluminum foil failed to prevent rapid losses of VOCs. En Core samplers and otherwise empty VOA vials were suitable transportation and storage chambers for samples. These chambers not only meet the initial requirement to retain VOCs for two days when held at $4 \pm 2^\circ\text{C}$ for transportation purposes, but frequently showed no significant loss of VOCs after placing in a freezer and storing at $-12 \pm 3^\circ\text{C}$ for an additional 12 days.

How to get copies of CRREL technical publications:

Department of Defense personnel and contractors may order reports through the Defense Technical Information Center:

DTIC-BR SUITE 0944
8725 JOHN J KINGMAN RD
FT BELVOIR VA 22060-6218
Telephone 1 800 225 3842
E-mail help@dtic.mil
msorders@dtic.mil
WWW http://www.dtic.dla.mil/

All others may order reports through the National Technical Information Service:

NTIS
5285 PORT ROYAL RD
SPRINGFIELD VA 22161
Telephone 1 800 553 6847 or 1 703 605 6000
1 703 487 4639 (TDD for the hearing-impaired)
E-mail orders@ntis.fedworld.gov
WWW http://www.ntis.gov

A complete list of all CRREL technical publications is available from:

USACRREL (CEERD-IM-HL)
72 LYME RD
HANOVER NH 03755-1290
Telephone 1 603 646 4338
E-mail techpubs@crrel.usace.army.mil

For information on all aspects of the Cold Regions Research and Engineering Laboratory, visit our World Wide Web site:
<http://www.crrel.usace.army.mil>

Special Report 99-5



**US Army Corps
of Engineers®**

Cold Regions Research &
Engineering Laboratory

Storage and Preservation of Soil Samples for Volatile Compound Analysis

Alan D. Hewitt

May 1999

PREFACE

This report was prepared by Alan D. Hewitt, Research Physical Scientist, Geological Sciences Division, U.S. Army Cold Regions Research and Engineering Laboratory (CRREL).

Funding for this work was provided by the U.S. Army Environmental Center, Martin H. Stutz, Project Monitor. The author thanks Dr. C.L. Grant and A.B. Crockett for critical review of the text.

This publication reflects the view of the author and does not suggest or reflect policy, practices, programs, or doctrine of the U.S. Army or of the Government of the United States.

CONTENTS

	Page
Preface	ii
Introduction	1
Sample transportation and storage and preparation protocols	4
Core barrel liners	4
En Core samplers	4
Empty VOA vials	6
Experimental methods	6
Core barrel liners	6
En Core samplers	7
Empty VOA vials	8
Analysis	10
Results	10
Discussion	13
Summary	19
Literature cited	20
Abstract	21

ILLUSTRATIONS

Figure	Page
1. Loss of trichloroethylene from a field sample stored in an uncovered core barrel liner in a plastic bag	2
2. Contaminated soil stored in sealed ampoules and held at two different temperatures	3
3. Modified 10-mL syringe and empty VOA vial	4
4. En Core sampler and attachable handles for sample collection and extrusion	5
5. In-field sampling and storage preparation of metal core barrel liners	7
6. Sampling pattern used for the En Core sampler trials	8

TABLES

Table	Page
1. Sample preparation, holding times, and storage conditions for VOA vial experiments	9
2. Average and standard deviations ($n = 3$) of analyte concentrations (mg/kg) for soil samples inside open and covered vials exposed to VOC vapor fortification for two days	10
3. Average and standard deviations ($n = 2$) of analyte concentrations (mg/kg) in covered brass core barrel liners stored for two and six days at $4 \pm 2^\circ\text{C}$	11
4. Comparison of average and standard deviation of concentrations (mg/kg) for samples removed from core barrel liners in the field (D0) vs. those stored for two and four days at $4 \pm 2^\circ\text{C}$ in core barrel liners covered with a thin metal disk lid, then wrapped with a sheet of translucent, nonelastic Teflon	12

5. Average and standard deviations ($n = 5$) of analyte concentrations ($\mu\text{g}/\text{kg}$) for samples stored in the En Core sampler after various holding periods under different storage conditions	13
6. Comparison of collocated samples collected with a 10-mL syringe vs. 5-g En Core sampler	14
7. Average and standard deviations ($n = 3$) of analyte concentrations (mg/kg) for spikes and samples after various holding periods in VOA vials under different storage conditions	15
8. Average and standard deviations ($n = 3$) of analyte concentrations ($\mu\text{g}/\text{kg}$) for the sample spike and samples after various holding periods in VOA vials under different storage conditions	16
9. Average and standard deviation ($n = 3$) of analyte concentrations for the sample spike and samples after various holding periods in VOA vials under different storage conditions	17
10. Average and standard deviation ($n = 3$) of analyte concentration (mg/kg) stability in sample VOA vials with punctured septa vs. VOA vials with intact septa	18

Storage and Preservation of Soil Samples for Volatile Organic Compound Analysis

ALAN D. HEWITT

INTRODUCTION

Most samples collected to identify and quantify analytes in hazardous waste require some form of preparation (e.g., extraction, subsampling, etc.) prior to instrumental analysis. This part of the total measurement process has traditionally taken place in an off-site laboratory. Therefore, samples obtained during the characterization stages of a site investigation or when monitoring the progress of a remediation activity often experience transportation and storage, in addition to collection, preparation, and analysis. During the last decade there has been a growing awareness of the many problems that can be encountered when attempting to maintain representative concentrations of hazardous waste constituents throughout the total measurement process. Volatile organic compounds (VOCs) have been especially suspect with regard to their identification and quantification in samples removed from the vadose zone (Hewitt et al. 1995).

In most contaminated soils and other solid waste materials, VOCs coexist in gaseous, liquid, and solid (sorbed) phases (Conant et al. 1996). Of particular concern to the collection, handling, and storage of samples for VOC characterization is the retention of the gaseous component. This phase exhibits molecular diffusion coefficients that allow for their immediate loss from a freshly exposed surface, and continued losses from within the body of the porous matrix (Siegrist and Jenssen 1990). Furthermore, once the gaseous phase becomes depleted, nearly instantaneous volatilization from the liquid and sorbed phases occurs in an attempt to restore the temporal equilibrium that often exists, thereby allowing the impact of this loss

mechanism to continue (Hewitt 1998a). We illustrate in Figure 1 how quickly VOCs are lost from the center of silty-sand soil held at ambient temperatures ($18 \pm 2^\circ\text{C}$) in an uncovered 3.6-cm-i.d. \times 5.1-cm-long metal core barrel liner stored in a plastic bag (Hewitt and Lukash 1996). The initial rapid loss of trichloroethylene (TCE) may represent TCE that was in a gaseous state at the time of sample collection. The change to a slower loss rate may represent this analyte when it must first go through a phase change, e.g., be desorbed or volatilized, prior to escaping.

Another mechanism that can influence VOC concentrations in samples that are transported and stored at $4 \pm 2^\circ\text{C}$ is biological degradation (Bradley and Chapella 1995, Hewitt 1997a). In general, this loss mechanism is not expected to be as large a source of determinate error as volatilization. This premise is based on the observation that losses of an order of magnitude can occur on a time scale of minutes to hours (see Fig. 1), due solely to diffusion and advection. In contrast, losses of a similar magnitude due to biological processes usually require days to weeks (Hewitt 1995a). Figure 2 is an example of the changes in concentration observed for several analytes in samples held in sealed glass ampoules and either stored at room temperature or in a refrigerator. This experiment was run under aerobic conditions, which is typical of most samples that are transported and stored. Under these conditions biological mechanisms favor the degradation of aromatic hydrocarbons over halogenated compounds. Therefore, besides giving a slower rate of analyte loss, biodegradation is compound selective.

To limit the influence of volatilization and biodegradation losses, the U.S. Environmental Pro-

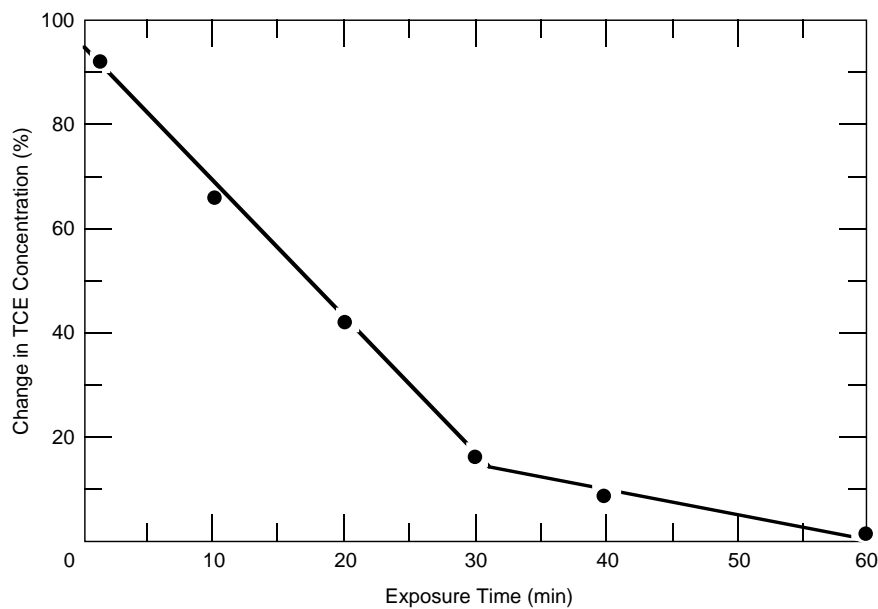

Figure 1. Loss of trichloroethylene from a field sample stored in an uncovered core barrel liner held in a plastic bag.

tection Agency (U.S. EPA 1986) has recommended the use of Methods 5035 and 5021. These new methods were published on 13 June 1997 as part of the third update of the *Test Methods for Evaluation of Solid Waste* (i.e., the SW-846). The guidance associated with these methods and supporting information available from the American Society for Testing and Materials (ASTM) D 4547-98, *Standard Guide for Sampling Waste and Soils for Volatile Organic Compounds*, address all of the facets of the total measurement process from collection to analysis. D 4547-98 is a revision of D 4547-91. A synopsis of the options that are currently recommended by these guidance documents for sample collection and preparation, but not necessarily preservation, are (1) the immediate in-field transfer of a sample into a weighed volatile organic analysis (VOA) vial that either contains VOC free water so that a vapor partitioning (purge-and-trap or headspace) analysis can be performed without reopening or that contains methanol (MeOH) for analyte extraction in preparation for analysis, or (2) the collection and up to two-day storage of intact samples in airtight containers before initiating one of the aforementioned sample preparation procedures. In both cases samples should be held at $4 \pm 2^\circ\text{C}$ while being transported from the sampling location to the laboratory.

The preanalysis holding period associated with these two alternatives is limited to two days un-

less some additional form of biological preservation is used. At the time these documents were published, two chemical preservation procedures, MeOH immersion and acidification to a pH of 2 with sodium bisulfate, received the most attention. Moreover, it was recommended that MeOH preservation be used only when samples were anticipated to contain concentrations of VOCs in excess of 0.2 mg/kg, and acidification when the concentrations were expected to be less than this value. Once the samples are preserved, the preanalysis holding period could be extended up to 14 days after sample collection. Other means of biological preservation, such as lowering the storage temperature to below 0°C , although briefly mentioned, did not receive as much support as these chemical preservation procedures, because of insufficient information.

The first option described has the field personnel initiate sample preparation during the collection activity, and may require that they handle solutions and weigh the sample collection vessels (Hewitt et al. 1995). The second option, which is the focus of this report, allows for the transportation and storage of samples, so that preparation can be performed in a laboratory setting. Currently, only one device is recommended by more than one of these documents for performing this task, i.e., the En Core sampler (En Novative Technologies, Inc., Green Bay, Wisconsin). This study

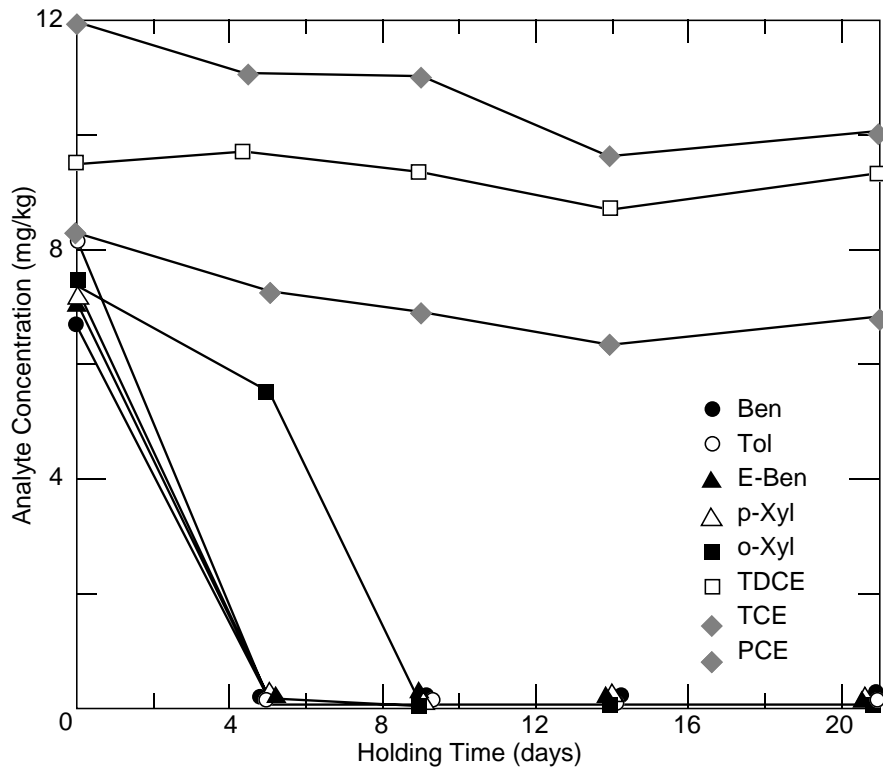

a) $21 \pm 2^\circ\text{C}$.

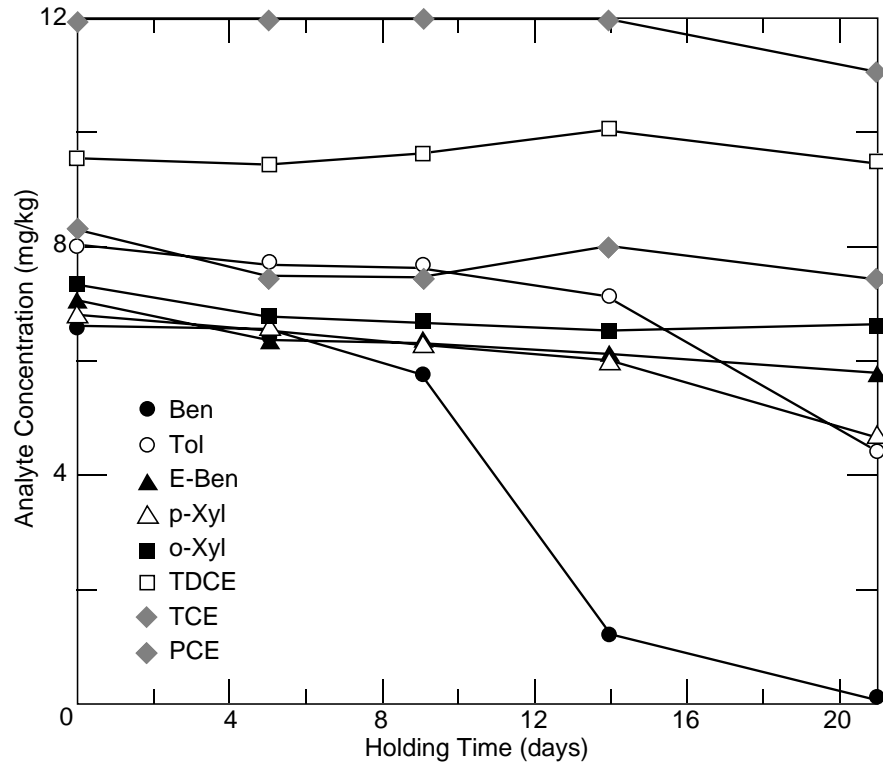

b) $4 \pm 2^\circ\text{C}$.

Figure 2. Contaminated soil stored in sealed ampoules and held at two different temperatures.

evaluates this device for the transportation and extended storage of samples along with covered core barrel liners and empty volatile organic analysis (VOA) vials (proposed by U.S. Analytical Laboratory, Kimberly, Wisconsin). Core barrel liners are open-ended tubes that fit inside a subsurface sampler; after filling by pushing into an previously undisturbed formation, the liners are covered allowing a bulk sample to be transported and stored. The En Core sampler and the empty VOA vial serve as chambers for the transportation and storage of discrete samples. The practices used to assess these sample transportation and storage devices are intended to comply with the current EPA and ASTM guidance, even though they may not be implicit to these documents. Furthermore, these experiments will attempt to determine whether storage at $-12 \pm 3^{\circ}\text{C}$ is a favorable method of sample preservation. A general description of how the samples would be transported, stored, and prepared for analysis follows.

SAMPLE TRANSPORTATION AND STORAGE AND PREPARATION PROTOCOLS

Core barrel liners

Subsurface soil samples are usually obtained with a hollow tube designed to collect an intact cylindrical core of material. Coring tubes typically range in size from 2.5 to 10 cm in diameter, and 25 to several hundreds of centimeters in length. Core barrel liners fit snugly within these coring tubes and come in a variety of sizes and materials (stainless steel, brass, Teflon, rigid plastics, etc.). Only core barrel liners made out of metal have been recommended for transportation and storage of samples for VOC analysis (ASTMD 4547-91). Once filled and returned to the surface, the ends of a core barrel liner are covered with either a thin sheet of Teflon or aluminum foil. To hold these sheets in place, plastic caps are pressed over the ends and in some cases an adhesive tape is also applied. These bulk samplers are transported and stored at $4 \pm 2^{\circ}\text{C}$ prior to the removal of a subsample in preparation for analysis. Subsampling is done through the core ends by (1) removing the coverings, (2) removing a few centimeters of soil, and (3) using a small coring tool, such as a modified 10-mL or smaller syringe (Fig. 3) to transfer a subsample to a VOA vial prepared for either direct vapor partitioning analysis or MeOH extraction. After the syringe is removed from the bulk sample, the exterior walls are wiped with a clean

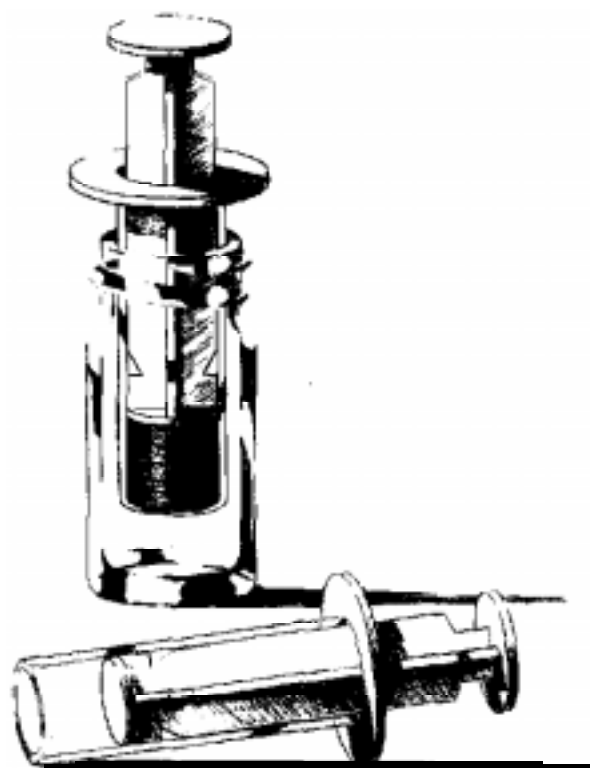

Figure 3. Modified 10-mL syringe and empty VOA vial. Syringe modified by removing tip and rubber plunger cap. (Commercially available from U.S. Analytical Laboratory, Kimberly, Wisconsin.)

cloth so as not to leave particles on the sealing edge of the sample preparation/analysis vial. Furthermore, the coring tool used for this subsampling step needs to have a smaller outer diameter than the opening of the sample vial.

En Core Samplers

The En Core sampler is available in two sizes allowing for the collection and storage of either a 5- or 25-g soil sample. Only the 5-g sampler was evaluated in this study. This precleaned device, composed of an inert composite polymer with Viton O-rings to form vapor-tight seals, is intended for a single use. To use this sampler the coring/storage chamber is attached to a metal handle (Fig. 4) and, with the plunger in the forward position (unsealed), the bottom of this tool is pushed into a freshly exposed surface until it is filled. Once the sampler is removed the exterior surfaces are wiped clean and the cap is installed. The sampler is then returned to a foil bag and held at $4 \pm 2^{\circ}\text{C}$. When the sample is prepared for either direct vapor partitioning (purge-and-trap or headspace) analysis or MeOH extraction, the sampler is at-

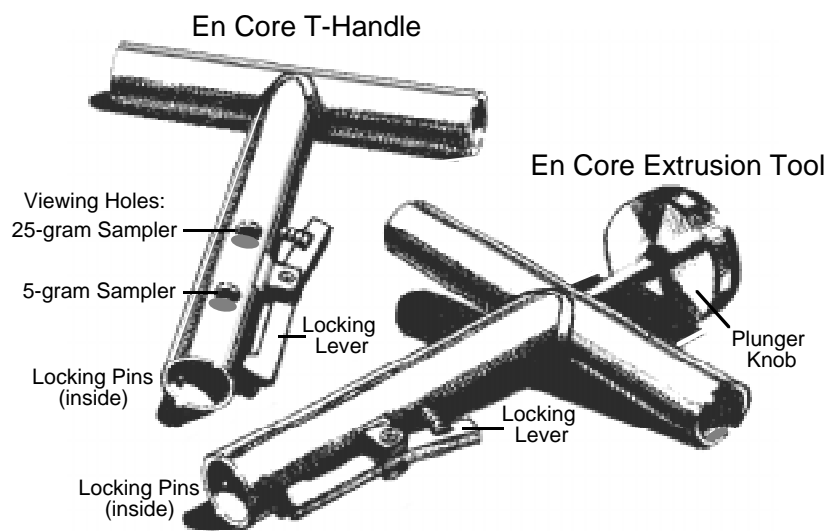
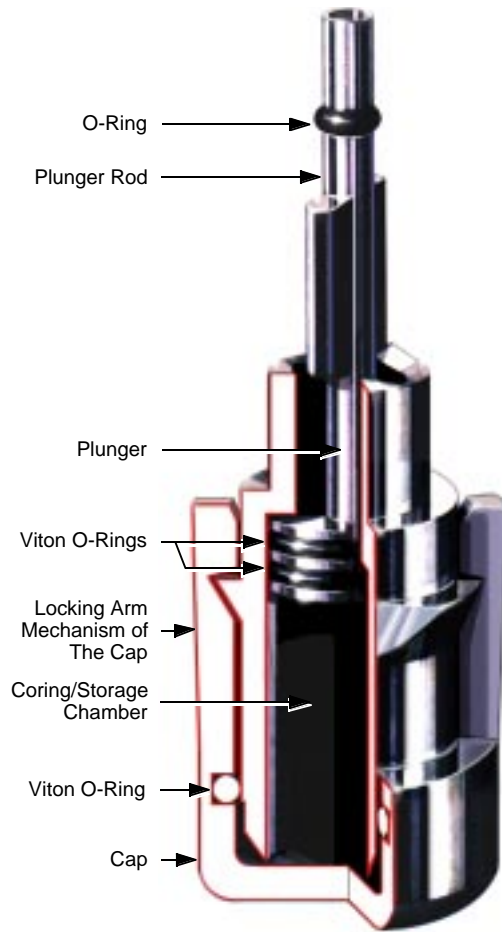

Figure 4. En Core sampler and attachable handles for sample collection and extrusion.

tached to a metal extrusion tool, the cap is removed, and the sample is extruded directly into the prepared VOA vial. By design the 5-g En Core sampler fits into the mouth of a 40-mL VOA vial.

Empty VOA vials

When using an empty VOA vial as a chamber, a 5-g sample is transferred with a modified syringe as described above. The VOA vial into which the sample is placed should already contain a Teflon-coated stir bar if it is to be analyzed directly using a purge-and-trap step (e.g., low-level Method 5035). After transferring, the sample the VOA vial is capped and placed in a cooler held at $4 \pm 2^\circ\text{C}$. In a laboratory setting, 5.00 mL of water or MeOH would be added to a VOA vial by piercing the septum. If performed manually, a 23-gauge or smaller needle should be used. If MeOH is introduced the soil samples should be gently dispersed by swirling the VOA vial so that the majority of the inner glass surfaces are rinsed. This step should be repeated a second time after allowing the sample to sit for a couple of minutes. Then the excess pressure caused by introducing 5.00 mL of MeOH can be released and the VOA vial resealed. Caution should be taken during sample dispersion not to wet the Teflon-coated septum, because this could compromise the resealing after venting. If an aqueous solution is introduced manually the VOA vial can be vigorously shaken after adding the solution because the cap is not removed to release the pressure. An aqueous solution can also be added mechanically by some automated purge-and-trap systems, via a needle sparger.

EXPERIMENTAL METHODS

All of the experiments described below used soils obtained at the Cold Regions Research and Engineering Laboratory (CRREL). The soil from this site is characterized as a cohesive silty-clay with an organic carbon content of less than 1.0% (Hach method 8097) and ranging in moisture from 10 to 20% (ASTM D2216-66). Two types of samples, field and spiked, were used in these experiments. Contaminated field samples are available at CRREL, because of the mishandling of TCE more than 20 years ago. Soil samples were also obtained from areas where TCE contamination is relatively low (<0.01 mg/kg), then spiked with chlorinated and aromatic compounds that are frequently found on hazardous waste sites (Plumb and Pitchford 1985).

Core barrel liners

Laboratory experiments

One experiment considered the diffusion of VOC vapors through two different formulations of Teflon sheeting. Nine 1.5-mL VOA vials were filled with 2 g of air-dried soil, then placed uncapped in a desiccator with CaCO_3 . A 4-mm hole was punched out of the middle of each septum, and then they were placed in the caps so that the Teflon side faced out (in this configuration the silicone side of the septa faced the glass vial). Three 8-mm disks were punched out of a sheet of Teflon that was white and had elastic properties (≈ 0.02 -mm-thickness "plumber's tape"), and three more came from a sheet that was translucent with no elastic properties (≈ 0.05 -mm thickness, obtained from Art's Manufacturing & Supply, Inc.). After two days the desiccant was removed. Then six disks were placed over the tops of separate vials and covered with the hole punched septa and caps. Caps and hole punched septa were also placed on the three vials with no covering. Then an organic solution spiked with trans-1,2-dichloroethene (TDCE), cis-1,2-dichloroethene (CDCE), TCE, tetrachloroethene (PCE), benzene (Ben), toluene (Tol), ethylbenzene (E-Ben), p-xylene (p-Xyl), and o-xylene (o-Xyl), was introduced and the desiccator closed. Additional information concerning this vapor fortification procedure can be found elsewhere (Hewitt and Grant 1995). After two days of exposure, the vials were quickly removed from the desiccator, their cap assemblies removed, and then each was placed into a 22-mL VOA vial containing 10 mL of water and quickly capped for analysis.

A second experiment involved 18 brass core barrel liners, 3.75×3.75 cm, that had been filled with relatively clean soil by pushing into a freshly exposed surface. After the external walls of each core barrel liner were wiped clean the bottoms were covered as follows: (1) four with a sheet of white, elastic Teflon, (2) four with a sheet of translucent, nonelastic Teflon, (3) four with a thin metal disk that was the same diameter as the core barrel liner followed by a sheet of translucent, nonelastic Teflon, and (4) four with a sheet of aluminum foil. Plastic end caps were used to hold all of these coverings in place. The soil in each core barrel liner was then spiked with 1.00 mL of an aqueous solution containing approximately 50 mg/L of each of the nine analytes previously mentioned. Information about the preparation of this aqueous solution and this spiking procedure is available elsewhere (Hewitt 1995a). The spikes were transferred

to the center of each soil core using a glass syringe after a pilot hole had been made. Immediately after each spiking, the same wrapping used to cover the bottom was used to cover the top. Two time zero ("D0,") control samples were prepared by placing an entire core barrel liner into a 2-oz (60 mL) wide-mouth VOA bottle, spiking with 1.00 mL of the aqueous solution, and then immediately adding 50 mL of MeOH and capping. The covered core liners were placed in a refrigerator ($4 \pm 2^\circ\text{C}$) and duplicates of each of the four different wrapping configurations were removed after 2 and 6 days of storage. After storage coverings were removed, and each core barrel liner was placed in a 2-oz (60-mL) VOA bottle and 50 mL of MeOH was added as with the controls.

Field experiment

Five brass core barrel liners (2.5 cm o.d. \times 8.6 cm long) were filled with soil after being placed end-on-end inside of a Mostap sampler that was then pushed into a contaminated formation by a cone penetrometer truck. After extraction, the core barrel liners were removed from the barrel of the Mostap sampler one at a time, so that the bottom of the soil core was available first. When the first core barrel liner section, and sequentially the following sections, cleared the outer barrel, a flat-bladed knife was used to make a smooth cross-sectional cut between the two rings. In the field, a subsample (≈ 5 g) was removed from the top of the first core liner with a 5-mL modified syringe. This subsample was placed immediately into a 22-mL VOA vial containing 10 mL of water and capped, to establish the D0 values (Fig. 5). The ends of the second core barrel liner were wiped clean, then thin metal disks (same diameter as the core barrel liner) were placed over the ends and wrapped with translucent, nonelastic Teflon sheet-

ing that was held in place with plastic end caps. Two subsamples were taken from the third core barrel liner, one from each end, using the procedure described for the first section. The fourth core barrel liner was wrapped in the same fashion as the second liner. Lastly, a subsample was taken from the bottom of the fifth core barrel liner. This sequence of sampling and wrapping core barrel liners was performed on three separate locations. The wrapped samples were immediately refrigerated ($4 \pm 2^\circ\text{C}$), and one core barrel liner from each of the three sets was removed after two and four days of storage and subsamples were removed from both ends. The subsamples were removed following the description given earlier for core barrel liners and prepared for analysis following the same procedures that had been used in the field.

En Core samplers

Laboratory experiment

Twenty 5-g En Core samplers were filled with relatively clean soil one at a time by pushing them into an undisturbed surface created by removing the first 28 cm. After each sampler was filled, a pilot hole was made into the middle of the soil plug using a 21-gauge needle. Using a 50- μL glass syringe (22-gauge needle), we added 50- μL of a dilute aqueous solution of the same nine analytes cited previously. After spiking each En Core sampler was capped and enclosed in a foil resealable bag.

In the laboratory, five of the En Core samplers, distributed from near the beginning to the end of the field collection and treatment process, were opened one at a time and the contents were extruded into weighed 40-mL VOA vials containing 5 mL of MeOH. These samples were used to establish the D0 concentration. The remaining En

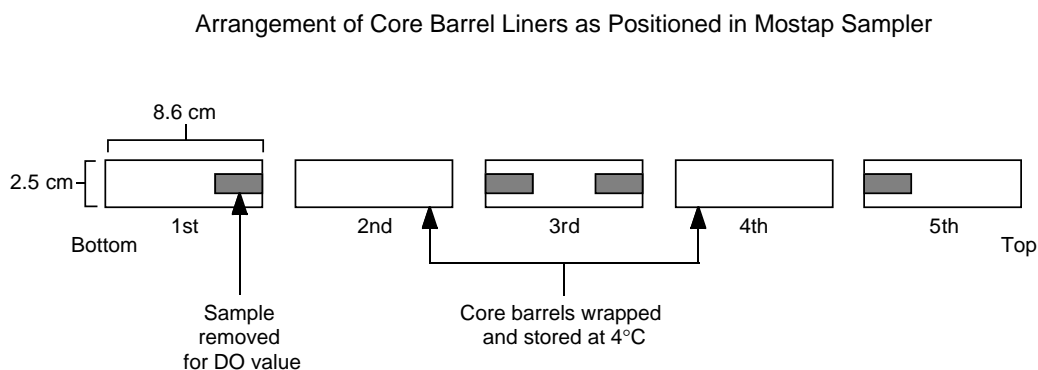

Figure 5. In-field sampling and storage preparation of metal core barrel liners.

Core samplers were placed in a refrigerator ($4 \pm 2^\circ\text{C}$). After two days, five were prepared for analysis and the 10 remaining En Core samplers were transferred to a freezer held at $-12 \pm 3^\circ\text{C}$. A set of five was analyzed after five and the last set was analyzed after 12 days of freezer storage.

Field experiments

Ten field experiments were performed with the 5-g En Core sampler. Each experiment consisted of taking 10 or 12 samples in close proximity (Fig. 6). Half of the samples were collected with a modified 10-mL syringe and half with En Core samplers. Samples taken with the modified syringes served as the controls and were immediately transferred (in the field) to weighed VOA vials containing either 5.0 or 10.0 mL of MeOH, to establish the D0 concentrations. A syringe was used for these samples so as not to deplete the supply of En Core samplers. Samples that were taken with the En Core sampler were held for either two or seven days at $4 \pm 2^\circ\text{C}$, or for two days at $4 \pm 2^\circ\text{C}$ followed by 12 additional days at $-12 \pm 3^\circ\text{C}$, prior to being extruded into weighed VOA vials containing the appropriate amount of MeOH. Additional information concerning this type of field experiment has been presented elsewhere (Hewitt 1997b).

Empty VOA vials

Only laboratory studies have been performed with the empty VOA vial approach to sample transportation and storage. All experiments used soils from area with low (<0.01 mg/kg) concentrations of TCE. After mixing in an aluminum pie pan, discrete 5.0 ± 0.1 g samples were transferred into empty 40-mL VOA vials by partially filling a 5-mL modified syringe. The weight of each soil plug was established by taring the empty syringe and adjusting the amount collected. The exterior

of the syringe barrel was wiped before the final weight of sample was recorded. In the first experiment the syringe contents were slowly extruded into 40-mL VOA vials. After preparing 24 replicates in this fashion, a 0.500-mL aliquot of an aqueous solution containing the aforementioned nine analytes at a concentration of approximately 50 mg/L was spiked onto the surface of each sample and the VOA vial was immediately capped. In addition to treating the 24 soil samples, three aliquots of the aqueous spiking solution were transferred to 40-mL VOA vials containing 5 mL of MeOH to establish the concentration of the spiking solution. These three solutions were prepared after the first, thirteenth, and last soil samples were treated.

After all the samples had been prepared, 5.00 mL of MeOH was introduced to the first, thirteenth, and last, so as to estimate the D0 concentrations. The MeOH was added by piercing each septum with a 23-gauge Luer Lok needle (B-D) attached to a 5.00-mL glass syringe (SGE) with a Luer connector. Of the remaining 21 samples, nine were stored at room temperature ($21 \pm 2^\circ\text{C}$), six were refrigerated ($4 \pm 2^\circ\text{C}$), and six were placed in a freezer ($-12 \pm 3^\circ\text{C}$). After three days, MeOH was introduced to sample triplicates that had been stored at room temperature. This process was repeated for sample triplicates stored at room temperature, refrigerated, and frozen after holding periods of seven and 14 days (Table 1).

In a second experiment, after obtaining 5.0 ± 0.1 g of soil in the syringe as described previously, a pilot hole was made with a needle into the middle of the soil plug. Then a 10- μL glass syringe was used to transfer a 5.00- μL aliquot of aqueous solution containing approximately 50 mg/L of the same nine analytes into this cavity. Then the syringe barrel was inserted into the mouth of the VOA vial, the sample extruded, and the vial was

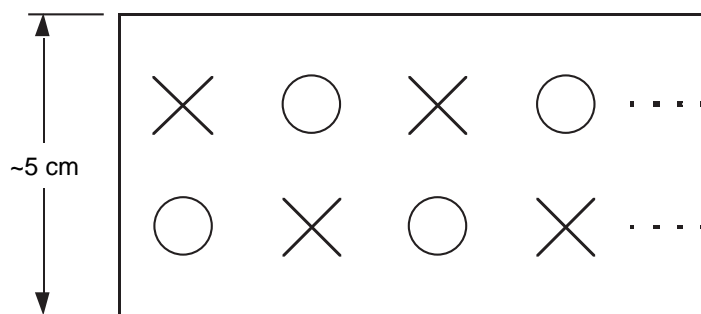

Figure 6. Sampling pattern used for the En Core sampler trials.

Table 1. Sample preparation, holding times, and storage conditions for VOA vial experiments.

First experiment

Soil plugs transferred to empty VOA vial then spiked ($n = 24$). Samples prepared for analysis by passing 5.00 mL of MeOH through septa.

<i>Day 0</i>	<i>Day 3</i>	<i>Day 7</i>	<i>Day 14</i>
NS ($n = 3$)*	21°C ($n = 3$)*	21°, 4°, & -12°C ($n = 3$)* × 3	21°, 4°, & -12°C ($n = 3$)* × 3

Second experiment (three sets)

A. Spiked soil plug transferred to VOA containing 5 mL of water ($n = 9$).

B. Spiked soil plug transferred to empty VOA vial ($n = 9$). Samples prepared for analysis by passing 5.00 mL of water through septa.

C. Spiked soil plug transferred to empty VOA vial ($n = 9$). Samples prepared for analysis by passing 5.00 mL of MeOH through septa.

For each set.

<i>Day 0</i>	<i>Day 4 or 5</i>	<i>Day 13 or 14</i>
NS ($n = 3$)*	4°C ($n = 3$)† ($n = 3$)*	-12°C ($n = 3$)*

Third experiment

Spiked soil plug transferred to empty VOA vial ($n = 18$). Samples prepared for analysis by passing 5.00 mL of MeOH through septa.

For each set.

<i>Day 0</i>	<i>Day 1</i>	<i>Day 2</i>	<i>Day 5</i>	<i>Day 7</i>	<i>Day 14</i>
NS ($n = 3$)*	4°C ($n = 3$)*	4°C ($n = 6$)† ($n = 3$)*	4°C ($n = 3$)*	-12°C ($n = 3$)*	-12°C ($n = 3$)*

NS Not stored.

* Number of replicate analyzed after a storage period.

† Number of replicates moved from one storage condition to another, after a given period.

capped. In all, three sets of samples were prepared in this fashion. The first set of nine was placed into 22-mL VOA vials that already contained 5 mL of organic free water. The second nine were placed in empty 40-mL VOA vials. The last nine were placed into empty 22-mL VOA vials. In addition to treating the soil samples, aliquots of the aqueous spiking solution were transferred to VOA vials, three containing 5.00 mL of MeOH and six containing 5.00 mL of water, to establish the spiking solution concentration for each set. After all the samples had been prepared, either 5.00 mL of MeOH or water was introduced to the first, fourth, and last of the samples contained in empty VOA vials (no additional water was added to the 22-mL VOA vials that already contained water) as described in the first experiment. Similarly spaced triplicates from all three sets were analyzed to es-

tablish the D0 analyte concentrations. For each of the sets, the six remaining samples were refrigerated ($4 \pm 2^\circ\text{C}$) for four or five days before triplicates were removed and analyzed. The remaining triplicates from each set were transferred to a freezer ($-12 \pm 3^\circ\text{C}$) and stored for an additional nine days prior to analysis (Table 1).

A third experiment was performed using only empty 40-mL VOA vials while following the same sample treatment procedure as the second experiment. For this experiment 18 replicates were made and samples were prepared for analysis by adding 5.00 mL of MeOH to the VOA vials. Triplicates were prepared for analysis on D0, and after one, two, and five days of storage at $4 \pm 2^\circ\text{C}$. In addition, after two days of storage at $4 \pm 2^\circ\text{C}$, six replicates were transferred to a freezer ($-12 \pm 3^\circ\text{C}$). Triplicates of the samples placed in the freezer were

removed and prepared for analysis after seven and 12 days of additional storage (Table 1).

In addition, aliquots of MeOH were removed after various storage periods from the solutions used to determine the spike concentration and from the D0 samples that had been prepared for the first empty VOA vial experiment. The purpose of reanalyzing these samples was to assess analyte concentration stability in MeOH held in VOA vials, with and without punctured septa. The solutions used to determine the spike concentration had intact septa, while the D0 samples had septa that had been punctured once.

ANALYSIS

All of the samples were analyzed by equilibrium headspace (HS) analysis. Soil samples that were analyzed directly were allowed to reach room temperature and then were vigorously hand-shaken for two minutes prior to automated HS analysis. Samples prepared by MeOH extraction typically sat for at least 24 hours, before a 0.100- to 0.500-mL aliquot was transferred to a 22-mL VOA vial containing 10 mL of organic-free water, capped, and then hand-shaken before automated HS analysis. Automated HS analysis was performed using an auto sampler (Tekmar 7000) coupled to a GC (SRI, model 8610-0058) with sequential photoionization, flame ionization detectors. The instrumental setting used was consistent with those reported elsewhere (e.g., Hewitt 1998b).

Concentration estimates were established relative to working standards. Working standards were prepared by spiking analysis vials that contained the same amount of organic-free water and MeOH as the samples to be analyzed, with small volumes (less than 10 μ L) of a MeOH stock standard. The stock standards were prepared on a weight basis, then volumetrically diluted with MeOH, as necessary. Samples prepared by MeOH extraction were corrected for the increase in extraction solution volume, caused by soil moisture. Sample prepared for direct HS/GC analysis were reported on a moist weight basis.

RESULTS

The first experiment (Table 2) showed that the white, elastic version of Teflon was rapidly penetrated by all nine VOCs tested. The translucent, nonelastic formulation was also permeated by

Table 2. Average and standard deviations ($n = 3$) of analyte concentrations (mg/kg) for soil samples inside open and covered vials exposed to VOC vapor fortification for two days.

Compound	Open	Vial covering	
		White Teflon*	Translucent Teflon†
TDCE	1.57 ± 0.03	1.54 (98%)** ± 0.04	0.12 (7.6%) ± 0.02
CDCE	3.33 ± 0.06	3.20 (96%) ± 0.10	0.14 (4.2%) ± 0.01
Ben	4.77 ± 0.08	4.65 (97%) ± 0.13	0.17 (3.5%) ± 0.01
TCE	2.60 ± 0.05	2.50 (96%) ± 0.07	0.16 (6.2%) ± 0.01
Tol	7.49 ± 0.20	6.37(85%) ± 0.04	0.18 (2.4%) ± 0.06
PCE	3.37 ± 0.05	3.22 (96%) ± 0.14	0.25 (7.4%) ± 0.01
E-Ben	2.97 ± 0.09	2.32 (78%) ± 0.032	0.10 (3.4%) ± 0.01
p-Xyl	2.96 ± 0.16	2.41 (81%) ± 0.04	0.10 (3.4%) ± 0.01
o-Xyl	1.85 ± 0.07	1.43 (77%) ± 0.02	0.09 (4.9%) ± 0.01

*White Teflon sheeting, elastic, approx. 0.02-mm thickness.

†Translucent Teflon sheeting, nonelastic, approx. 0.05-mm thickness.

**Percent of soil VOC concentration found in Teflon (sheet) covered vials vs. open vials.

VOCs, but at a much slower rate. The disparity in performance of these two formulations of Teflon sheeting is also apparent in Table 3, which shows the recoveries of spiked analyte concentrations from soils stored in covered core barrel liners. VOCs escaped from the bulk soil samples wrapped with the white, elastic version of Teflon sheeting much faster than those covered with the translucent, nonelastic version. Table 3 also shows that aluminum foil or the addition of a thin metal plate as a lid over the end of the core barrel liner prior to wrapping with the translucent Teflon sheeting, failed to prevent rapid and continuous losses of VOCs.

Although these laboratory experiments and others (Hewitt and Lukash 1996) have shown that this approach to transporting and storing samples for VOC analysis is suspect, an additional experiment was performed using contaminated field samples. Effects established with spiked samples can be

Table 3. Average and standard deviations ($n = 2$) of analyte concentrations (mg/kg) in covered brass core barrel liners stored for two and six days at $4 \pm 2^\circ\text{C}$.

<i>Analyte concentrations (mg/kg)</i>									
<i>Compound</i>	<i>D0</i>	<i>2 days</i>				<i>6 days</i>			
		<i>W-T*</i>	<i>A-F†</i>	<i>T-T**</i>	<i>T-ST††</i>	<i>W-T</i>	<i>A-F</i>	<i>T-T</i>	<i>T-ST</i>
TDCE	23	3.8	4.8	11	6.8	1.7	1.0	2.0	1.1
	± 0	± 0.1 17%***	± 3 21%	± 2 48%	± 1 30%	± 0.3 7.4%	± 0.1 4.3%	± 0.3 8.7%	± 0.1 4.7%
CDCE	35	12	13	26	20	4.4	3.2	6.7	4.1
	± 1	± 1 34%	± 6 37%	± 3 76%	± 2 57%	± 1 13%	± 0.8 9.1%	± 3 19%	± 0.3 12%
Ben	24	6.3	8.1	16	12	2.9	8.4	3.4	2.1
	± 1	± 1 26%	± 4 34%	± 1 67%	± 1 50%	± 1 12%	± 0.7 35%	± 1 14%	± 0.2 8.8%
TCE	35	12	14	24	20	8.4	6.8	10	7.9
	± 6	± 1 34%	± 6 40%	± 2 68%	± 1 59%	± 2 24%	± 0.5 19%	± 1 29%	± 0.4 23%
Tol	32	13	16	26	26	8.9	6.1	12	8.9
	± 3	± 3 41%	± 9 50%	± 0.1 81%	± 1 81%	± 1 28%	± 2 19%	± 3 38%	± 0.2 28%
PCE	25	11	12	20	20	8.6	6.4	12	9.4
	± 3	± 3 44%	± 7 48%	± 0.1 80%	± 0.4 80%	± 1.6 34%	± 2.1 26%	± 2 48%	± 0.3 38%
E-Ben	34	20	20	30	31	14	12	21	18
	± 5	± 5 59%	± 11 59%	± 1 88%	± 0.5 91%	± 2 41%	± 3 35%	± 2 62%	± 0.8 53%
p-Xyl	34	20	22	32	32	14	13	24	20
	± 5	± 5 59%	± 10 65%	± 2 94%	± 2 94%	± 2 41%	± 3 38%	± 2 70%	± 0.2 59%
o-Xyl	33	23	24	33	33	17	18	31	26
	± 7	± 5 70%	± 10 73%	± 2 100%	± 2 100%	± 2 52%	± 3 55%	± 2 94%	± 0.6 76%

*W-T white, elastic Teflon sheeting.

†A-F aluminum foil.

**T-T translucent, nonelastic Teflon sheeting.

††T-ST thin steel plate and translucent, nonelastic Teflon sheeting.

***Percent recovery relative to the control.

misleading; e.g., they show greater impacts than what would be experienced by field samples contaminated some time in the past. For example, VOCs in field samples may be less readily available than in spiked samples. The results in Table 4, although not covering as many analytes, support the laboratory-based experiments. Comparing the TDCE, CDCE, and TCE mean concentrations for field samples established on D0 vs. those established after two and four days of storage at $4 \pm 2^\circ\text{C}$ showed similar losses as seen for laboratory-treated soils stored under the same conditions.

The En Core sampler was also evaluated using

both laboratory and field-contaminated soil samples. Table 5 shows the concentration stability of nine VOCs spiked into soil samples that were held in En Core samplers and stored for two days under the conditions that are currently recommended by EPA and ASTM, as well as for 5 and 12 additional days at $-12 \pm 3^\circ\text{C}$. The results of this experiment were evaluated using a one-way analysis of variance (ANOVA) and least significance difference tests (Fisher's Protected LSD), at the 95% confidence level. This evaluation showed that there were small but statistically significant losses of TDCE, CDCE, Ben, and Tol during the

Table 4. Comparison of average and standard deviation of concentrations (mg/kg) for samples removed from core barrel liners in the field (D0) vs. those stored for two and four days at $4 \pm 2^\circ\text{C}$ in core barrel liners covered with a thin metal disk lid, then wrapped with a sheet of translucent, non-elastic Teflon.

Compound	Storage period		
	D0*	D2**	D4
1st Coring			
TDCE	ND†	ND	ND
CDCE	ND	ND	ND
TCE	0.62±0.08	0.40±0.07 65%††	0.11±0.04 18%
2nd Coring			
TDCE	ND	ND	ND
CDCE	0.25±0.04	0.15±0.01 60%	0.12±0.01 48%
TCE	0.42±0.07	0.24±0.02 57%	0.11±0.11 26%
3rd Coring			
TDCE	0.095±0.038	0.064±0.004 67%	ND
CDCE	0.47±0.09	0.35±0.01 74%	0.10±0.03 21%
TCE	0.24±0.06	0.14±0.01 58%	0.024±0.011 10%

*n = 4.

**n = 2.

†ND = Not detected.

††Percentage found relative to the D0 analyte concentration.

first two days of storage at $4 \pm 2^\circ\text{C}$. Furthermore, this slow rate of loss appears to have continued for Ben and TDCE after the samples in the En Core samplers were moved to the freezer. The remaining analytes (TCE, PCE, E-Ben, p-Xyl, and o-Xyl) showed no statistically significant changes in analyte concentrations relative to D0, while CDCE, and Tol showed no statistically significant reduction in concentration after being placed in the freezer (e.g., relative to D2).

Each of the 10 field trials (Table 6) involving the 5-g En Core sampler was initially evaluated using the Students' t-test at a 95% confidence interval. This statistical analysis showed that in only one case was there a difference between the mean TCE concentrations. The trial (trial 6) that had significant difference between the mean values showed that a slightly lower (12%) TCE concentration existed for the soil samples obtained and stored in the En Core sampler for seven days at $4 \pm 2^\circ\text{C}$,

prior to preparing for analysis. The results of these experiments involving field-contaminated soils were very consistent with the laboratory findings for this analyte (Table 5), e.g., no statistically significant change in concentration over a short two-day holding period, and frequently no significant change over extended holding periods.

The first laboratory experiment using empty VOA vials as containers for transporting and storing soil samples evaluated the effect of storage temperature. The results in Table 7 show the same trends in analyte concentration relative to room temperature and refrigerated storage, as seen in experiments performed using sealed glass ampoules as storage chambers (Fig. 2, Hewitt 1995a). At room temperature there was rapid degradation of the aromatic compounds. Indeed, after seven days of storage at $21 \pm 2^\circ\text{C}$, Ben, Tol, E-Ben, and p-Xyl were not detected. When stored at $4 \pm 2^\circ\text{C}$ for 14 days, these same four aromatic compounds were reduced in concentration by more than 60% from the D0 values. With the exception of CDCE, the chlorinated compounds showed much smaller losses for these storage periods and conditions. When these samples were stored at $-12 \pm 3^\circ\text{C}$, the concentrations established after 14 days of storage in freezer were within 5% of the values established on D0. This table also shows that there was good agreement between the spike and D0 analyte concentrations.

In the second experiment, we compared introducing spiked samples to a VOA vials that already contained a solution vs. introducing them to empty VOA vials and then adding solution through the septum after various storage periods and conditions. Direct headspace analysis vs. MeOH extraction was also compared. Table 8, which shows the results of these comparisons, indicates (1) there is no apparent effect caused by introducing the water through septa, (2) analyte recoveries relative to the spike concentration were not as accurate for samples dispersed in water and analyzed directly as opposed to those extracted with MeOH, and (3) losses of aromatic compounds decreased when frozen. The first observation suggests that adding an aqueous solution through septum, as would be necessary for either headspace or purge-and-trap analysis, is comparable to having the aqueous solution present in the VOA vial at the time of sample collection. The discrepancy in analyte recovery relative to these two methods of sample preparation, i.e., vapor partitioning vs. MeOH extraction, is consistent with that of earlier studies (Askari et al. 1996, Minnich et al. 1996, Hewitt

Table 5. Average and standard deviations ($n = 5$) of analyte concentrations ($\mu\text{g}/\text{kg}$) for samples stored in the En Core sampler after various holding periods under different storage conditions. Analyte concentrations were established based on a moist soil basis, and average weight of 5.1 g.

<i>Compound</i>	<i>D0</i>	<i>D2</i> <i>4°C</i>	<i>D7*</i> <i>4° & -12°C</i>	<i>D14†</i> <i>4° & -12°C</i>
TDCE	292a** ±19	233b (80%)†† ±9.4	183c (63%) ±19	194b,c (65%) ±53
CDCE	280a ±19	242b (86%) ±1.4	218b (78%) ±8.3	223b (80%) ±34
Ben	206a ±14	175b (85%) ±3.3	154c (75%) ±8.3	153c (74%) ±24
TCE	306a ±25	278a (91%) ±3.9	265a (87%) ±8.8	284a (93%) ±37
Tol	237a ±20	205c (86%) ±5.5	205c (86%) ±8.2	218b,c (92%) ±22
PCE	197a ±15	188a (95%) ±3.2	183a (93%) ±7.2	203a (103%) ±26
E-Ben	195a ±19	182a (93%) ±7	184a (94%) ±9.8	194a (99%) ±18
p-Xyl	201a ±19	184a (92%) ±4.9	190a (94%) ±9.8	206a (102%) ±16
o-Xyl	214a ±21	209a (98%) ±9.8	209a (98%) ±12	219a (102%) ±25

*Stored for 7 days; 2 days at $4\pm 2^\circ\text{C}$ and 5 days at $-12\pm 3^\circ\text{C}$.

†Stored for 14 days; 2 days at $4\pm 2^\circ\text{C}$ and 12 days at $-12\pm 3^\circ\text{C}$.

**Values with common letter are not significantly different at the 95% confidence interval (ANOVA and Fisher's Protected LSD).

††Percent recovery relative to D0 analyte concentration.

1998b). The third observation suggests the biological degradation can be slowed down and perhaps prevented by storing a sample at $-12 \pm 3^\circ\text{C}$. In this experiment, while large decreases (40% or greater) in Ben, Tol, E-Ben, p-Xyl, and CDCE concentrations occurred after four or five days of storage at $4 \pm 2^\circ\text{C}$, much smaller losses, if at all, were seen after transferring to a freezer and holding for nine more days.

The results of the final experiment of the empty VOA vial were also evaluated using a one-way analysis of variance (ANOVA) and least significance difference tests (Fisher's Protected Least Significant Difference), at the 95% confidence level (Table 9). This evaluation showed that during refrigerated storage there was a slow continuous decrease in all of the aromatic hydrocarbons, with the possible exception of o-Xyl, and a fairly continuous loss of TDCE and CDCE. However, once placed in the freezer, losses were abated even though storage was extended for another 12 days.

Overall, these findings parallel the results of the laboratory experiment performed with the En Core sampler.

Table 10 contains the results for analyte stability in VOA vials with and without a punctured septum. VOA vials without punctured septa showed no apparent change in analyte concentration over a 21-day storage period. However, all of the analytes in a MeOH/soil slurry held in VOA vials with punctured septa showed a continuous decrease in concentration with time. The rate of analyte loss from the VOA vials with punctured septa appears to be around 5 to 10% per week of storage.

DISCUSSION

Before the third update of SW-846, the majority of soil samples collected for characterization of VOC contamination followed procedures recom-

Table 6. Comparison of collocated samples collected with a 10-mL syringe vs. 5-g En Core sampler. Samples obtained with the syringe were immediately prepared for analysis. Samples obtained with the En Core sampler were stored under the conditions stated below.

	Syringe (mg TCE/kg)	En Core (mg TCE/kg)	% Recovery relative to syringe
A. Samples held for two days at 4 ± 2°C in En Core samplers (n = 5).			
Trial 1	89.7±15.0†	76.3±19.7**	85%
Trial 2	263±27.8	243±37.9**	92%
Trial 3	513±36.6	455±46.3**	89%
Trial 4	508±45.1	492±40.2**	97%
B. Samples held for seven days at 4 ± 2°C in En Core samplers (n = 5).			
Trial 5	238±26.1	204±62.7**	86%
Trial 6	380±36.0	336±21.3	88%
Trial 7	550±51.3	471±70.3**	86%
Trial 8	544±33.0	510±52.3**	94%
C. Samples held for two days at 4 ± 2°C and additional 12 days at -12 ± 3°C in En Core samplers (n = 6).			
Trial 9	16.1±11.5	12.7±4.7**	79%
Trial 10	19.3±5.2	17.7±3.3**	92%

†Average and standard deviation.

**Not significantly different at 95% confidence limit (Student's t-test).

mended in Method 5030. Briefly, bulk samples were collected without attention to how much fragmentation of the substrate occurred while quickly filling a transportation and storage bottle to capacity. The bulk sample remained in the bottle while being transported and stored at 4 ± 2°C. After storage, which could last up to 14 days a sample of approximately 5 g was removed with a metal spatula and weighed in an uncapped vessel prior to either the addition of MeOH or attachment to a purge-and-trap manifold. This method of collection, storage, and subsampling causes highly variable losses of VOCs, the extent of which is believed to have resulted in the reporting of biased concentrations that reflected less than 10%, and sometimes less than 1% of the in-situ levels of contamination (Urban et al. 1989, Siegrist and Jenssen 1990, Illias and Jaeger 1993, Lewis et al. 1994, Hewitt et al. 1995, Liikala et al. 1996, Smith et al 1996). The loss mechanisms most frequently cited were volatilization caused by sample exposure, and sec-

ondly, biodegradation caused by a lack of adequate sample preservation.

Another fairly common practice that was adopted on a state-by-state basis was the use of metal core barrel liners covered with sheets of Teflon or aluminum foil as transportation and storage vessels. Presumably, the same storage conditions, holding period, and sampling practices that existed for samples stored in bottles were used for core barrel liners. To date only one study has addressed the performance of core barrel liners (Hewitt and Lukash 1996). This initial study exposed several potential problems with this method; the most important was that this approach to bulk sample storage failed to prevent volatilization losses. However, this earlier study only considered one of the formulations of Teflon sheeting that are commercially available for this application. Here an evaluation was performed on a translucent, nonelastic formulation of Teflon, a white, elastic formulation of Teflon, and aluminum foil.

Although the translucent, nonelastic formulation of Teflon was superior to these other coverings, it was also susceptible to volatilization losses with both laboratory-treated and field-contaminated soils. The nonelastic version may have performed better than the other type of Teflon, because it is thicker (0.05 mm vs. 0.02 mm) and differs in physical composition. Independent of formulation, the losses incurred by the Teflon sheeting were attributed to permeation, while those for the aluminum foil were initially attributed to a poor seal (folds in the sheeting) around top edge of the core barrel liner (Hewitt and Lukash 1996). However, in addition to the poor sealing quality of aluminum foil, holes can be created in this covering with time (six days), presumably caused by galvanic corrosion. This technique for transporting and storing a bulk sample, nonetheless, is most likely superior to using a bottle because the substrate experiences less exposure and disaggregation before laboratory subsampling. Regardless of this comparison, storage in covered core barrel liners should no longer be recommended when VOCs are of concern, because these coverings are incapable of serving as a hermetic barrier for VOCs, as specified by both Method 5035 and D4547-98.

The sample collection, handling, and preparation methods described here for the VOA vial (bottle) and En Core sampler (chamber) limit sample exposure and substrate disaggregation. Both of these transportation and storage vessels

Table 7. Average and standard deviations ($n = 3$) of analyte concentrations (mg/kg) for spikes and samples after various holding periods in VOA vials under different storage conditions ($21 \pm 2^\circ\text{C}$, $4 \pm 2^\circ\text{C}$, and $-12 \pm 3^\circ\text{C}$).

Cmpd	Analyte concentrations (mg/kg)								
	Spike	D0	D3 21°C	D7			D14		
				21°C	4°C	-12°C	21°C	4°C	-12°C
TDCE	3.82 ±.17	3.48 ±.10	3.27 ±.15 94%*	3.00 ±.12 86%	3.11 ±.32 89%	3.35 ±.04 96%	2.32 ±.06 67%	3.04 ±.12 87%	3.34 ±.04 96%
CDCE	3.88 ±.04	3.73 ±.03	3.16 ±.08 84%	2.25 ±.09 60%	3.33 ±.35 89%	3.52 ±.08 94%	1.56 ±.28 42%	3.30 ±.06 89%	3.65 ±.04 98%
Ben	2.95 ±.04	2.77 ±.08	1.45 ±.19 52%	ND† ±.30 <1%	2.50 ±.01 90%	2.69 ±.06 97%	ND <1%	0.09 ±.01 3.2%	2.79 ±.02 101%
TCE	4.01 ±.08	3.79 ±.07	3.62 ±.13 95%	3.43 ±.12 90%	3.58 ±.33 94%	3.74 ±.05 98%	2.82 ±.12 74%	3.55 ±.04 94%	3.76 ±.04 99%
Tol	3.36 ±.10	3.11 ±.07	0.89 ±.13 29%	ND <1%	2.72 ±.23 88%	2.99 ±.06 96%	ND <1%	0.73 ±.21 23%	3.06 ±.03 98%
PCE	2.44 ±.04	2.33 ±.09	2.18 ±.06 94%	2.06 ±.04 89%	2.13 ±.15 92%	2.27 ±.03 97%	1.75 ±.08 75%	2.06 ±.04 89%	2.24 ±.04 96%
E-Ben	2.86 ±.04	2.69 ±.08	0.71 ±.39 26%	ND <1%	2.29 ±.12 85%	2.59 ±.04 96%	ND <1%	0.59 ±.18 22%	2.56 ±.04 95%
p-Xyl	2.94 ±.07	2.72 ±.08	0.98 ±.32 36%	ND <1%	2.30 ±.13 84%	2.63 ±.04 97%	ND <1%	1.02 ±.12 38%	2.65 ±.06 97%
o-Xyl	3.05 ±.08	2.88 ±.10	2.48 ±.04 86%	1.37 ±.10 47%	2.60 ±.17 90%	2.74 ±.04 95%	ND <1%	2.68 ±.08 93%	2.85 ±.08 99%

* Percent recovery relative to D0 sample concentration.

† Not detected.

are for the most part composed of materials that are inert with respect to VOCs. However, their respective removable closures rely on formulations of Teflon to produce a hermetic seal. The VOA vial uses a 0.25-mm (10-mil) or thicker Teflon sheet attached to a silicone septum, to serve as a compressible surface to seal against the glass rim. The En Core sampler uses Viton O-rings compressed against a rigid plastic surface (50% glass-filled nylon) to create seals at both ends of the sample coring/storage chamber (Fig. 4). These polymeric materials have some limited adsorption properties and they also allow for the slow permeation of VOCs. When used as chambers for discrete soil samples, typically 80% or better of the initial con-

centration of VOCs was recovered following two days of storage at $4 \pm 2^\circ\text{C}$. Moreover, usually there was no further significant loss of VOCs when samples were transferred to a freezer and stored at $-12 \pm 3^\circ\text{C}$ for an additional 12 days. Therefore, discrete samples could be collected and held for up to two days at a temperature that is compatible with the logistics of field operations. Then, if a longer holding time was necessary, they could be stored in a freezer on- or off-site, for up to an additional 12 days, before being prepared and analyzed.

Freezing offers several advantages over the recommended in-field chemical preservation option, e.g., no prior knowledge of the VOC concentra-

Table 8. Average and standard deviations ($n = 3$) of analyte concentrations ($\mu\text{g}/\text{kg}$) for the sample spike and samples after various holding periods in VOA vials under different storage conditions. From D0 to D5 or D4 at $4 \pm 2^\circ\text{C}$, and from D5 or D4 to D14 or D13 at $-12 \pm 3^\circ\text{C}$.

<i>Procd./Store*</i>	<i>TDCE</i>	<i>CDCE</i>	<i>Ben</i>	<i>TCE</i>	<i>Tol</i>	<i>PCE</i>	<i>E-Ben</i>	<i>p-Xyl</i>	<i>o-Xyl</i>
A. Soil added to water in VOA vial									
Spike	36±1	47±1	22±1	54±1	29±1	39±1	30±1	28±1	31±1
D0	29±1	36±1	17±1	41±3	19±1	25±3	15±2	13±1	14±1
D5	19±3	20±3	10±1	30±3	8.5±1	20±2	5.9±1	3.8±1	9.8±1
	65%†	55%	59%	73%	45%	80%	39%	29%	70%
D14	16±1	17±1	8.9±1	28±2	7.1±1	19±2	5.5±1	3.3±1	9.4±1
	55%*	47%	52%	68%	37%	76%	37%	25%	67%
B. Water added to soil in VOA vial									
Spike	35±1	45±2	21±1	52±1	28±1	38±2	30±1	28±1	32±1
D0	28±1	35±1	17±1	40±1	19±1	27±1	17±1	14±1	16±1
D4	18±1	19±1	11±1	31±1	9.1±1	23±1	6.8±1	4.3±1	11±1
	64%	54%	65%	78%	48%	85%	40%	30%	69%
D13	14±1	16±2	9.4±1	26±1	7.6±1	20±1	5.4±1	3.5±1	8.6±1
	50%*	46%	55%	65%	40%	74%	32%	25%	54%
C. MeOH added to soil in VOA vial									
Spike	40±1	49±1	23±1	56±1	29±1	40±1	32±1	30±2	34±2
D0	38±3	47±3	22±1	52±3	31±1	41±2	29±1	26±1	34±1
D5	30±1	27±2	13±1	47±1	13±1	36±1	14±1	12±1	26±2
	79%	57%	59%	90%	42%	87%	48%	46%	76%
D14	27±2	28±3	11±1	47±1	12±1	37±2	13±2	10±2	26±2
	71%	60%	50%	90%	39%	90%	45%	38%	76%

*Sample preparation procedure and storage times.

†Percent recovery relative to D0 sample concentration.

tions is necessary, few Department of Transportation (DOT) regulatory requirements must be met, and field personnel don't have to handle chemicals or weigh samples. The first and last advantages listed above go hand-in-hand, and allow samplers to perform sample collection and tracking in a fashion that is similar to what was performed under the guidance from Method 5030. The amount of training to cover the change from spatulas to modified syringes or En Core samplers would be easily addressed in comparison to that which would be necessary to establish and supervise protocols for the handling of MeOH and acidified aqueous solutions. Moreover, preservation by acidification cannot be used indiscriminately; that is, this technique cannot be used with carbonate soils or when styrene is a VOC of interest (Hewitt 1995a). An additional concern is that by lowering the pH (with sodium bisulfate) of some matrices, the formation of acetone, a regulated compound itself, has been observed*.

*Personal communication, Daksha Dalal, USACE, Kansas City District, 1998, and several others.

Although not reported here, preliminary experiments have been performed to investigate the appearance of acetone in soil samples preserved with sodium bisulfate. Consistent with earlier reports, acetone was detected in freshly collected CRREL soils (5 g) preserved with sodium bisulfate (1 g), while it was not found in collocated samples that were not acidified. Furthermore, with the exception of Ottawa sand, acetone was found when analyzing soils that had been air-dried and sieved in preparation for laboratory studies. In the case of the laboratory soils, acetone was found in both acidified and nonacidified samples; however, there was a two-fold greater concentration of acetone in the acidified samples. Greater concentrations of acetone in laboratory soils and its appearance in-field soils was found to be associated with both lowering the pH and presence of sodium. While not conclusive, the source of acetone is likely to be the decomposition of natural biologically produced compounds in either low pH or reduced moisture conditions.

When storage at $-12 \pm 3^\circ\text{C}$ is used as the method of sample preservation, two or three collocated samples could be collected, transported, and

Table 9. Average and standard deviation ($n = 3$) of analyte concentrations for the sample spike and samples after various holding periods in VOA vials under different storage conditions (D1, D2, and D5 at $4 \pm 2^\circ\text{C}$, and from D2 to D9 or D14 at $-12 \pm 3^\circ\text{C}$).

<i>Analyte concentrations ($\mu\text{g}/\text{kg}$)</i>							
<i>Cmpd</i>	<i>Spike</i>	<i>D0</i>	<i>4°C storage</i>			<i>-12°C storage after 2 days of 4°C storage</i>	
			<i>D1</i>	<i>D2</i>	<i>D5</i>	<i>D9</i>	<i>D14</i>
TDCE	32	32a*	28b	26c	26c	26c	26c
	± 1	± 1	± 2 88%†	± 1 81%	± 1 81%	± 1 81%	± 1 81%
CDCE	47	47a	40b	36c	32d	34c,d	35c
	± 3	± 1	± 2 85%	± 3 79%	± 2 68%	± 1 72%	± 1 74%
Ben	30	30a	26b	23c	20d	24c	24c
	± 1	± 1	± 1 86%	± 1 77%	± 1 67%	± 2 80%	± 1 80%
TCE	49	49a	49a	49a	50a	50a	52a
	± 1	± 1	± 1 100%	± 1 102%	± 2 102%	± 3 102%	± 2 106%
Tol	32	32a	29b	25c	21d	25c	25c
	± 1	± 1	± 1 91%	± 1 78%	± 1 66%	± 2 78%	± 1 78%
PCE	33	33a	33a	31a	32a	31a	31a
	± 1	± 1	± 1 100%	± 1 94%	± 1 97%	± 2 94%	± 1 94%
E-Ben	23	22a,b	23a	18c,d	15d	19b,c	19b,c
	± 1	± 1	± 4 105%	± 2 82%	± 3 68%	± 2 86%	± 1 86%
p-Xyl	23	21a,b	22a	18b,c	15c	19a,b	18b,c
	± 1	± 1	± 2 105%	± 2 86%	± 3 71%	± 3 90%	± 1 86%
o-Xyl	28	28a	29a	26a	20b	27a	26a
	± 1	± 1	± 2 104%	± 1 93%	± 3 71%	± 1 96%	± 2 93%

*Values with common letter are not significantly different at the 95% confidence interval (ANOVA and Fisher's Protected LSD).

†Percent recovery relative to D0 sample concentration.

stored using En Core samplers or a modified syringe and empty VOA vials. The first sample prepared for analysis could be extracted with MeOH and could be either screened or formally analyzed using an accepted method. When screened and found to have a high concentration of VOCs, an aliquot from the same sample could then be run using an accepted method of analysis. If initially analyzed by an accepted procedure and if the analytes of interest fell within the calibration range, sample analysis would be finished. When

screened or analyzed formally and the analytes were not detected or a low concentration of VOCs was established, a collocated sample could be removed from the freezer and run directly by a vapor partitioning method of analysis using only an aqueous solution. Because lower detection methods typically allow for only a single analysis to be performed per sample, a third collocated sample would serve as a backup. One caveat when using this approach is that a stirring bar should be included in VOA vials prior to transferring a sample

Table 10. Average and standard deviation ($n = 3$) of analyte concentration (mg/kg) stability in sample VOA vials with punctured septa vs. VOA vials with intact septa.

<i>Cmpd</i>	<i>Intact septa spiking solution</i>				<i>Punctured septa samples</i>			
	<i>D0*</i>	<i>D7</i>	<i>D14</i>	<i>D21</i>	<i>D0</i>	<i>D7</i>	<i>D14</i>	<i>D21</i>
TDCE	3.82 ±.17 99%*	3.78 ±.21 97%	3.71 ±.18 96%	3.65 ±.26 96%	3.48 ±.10 84%	2.93 ±.27 74%	2.57 ±.38 59%	2.04 ±.50 59%
CDCE	3.88 ±.04 97%	3.78 ±.19 97%	3.82 ±.10 98%	3.82 ±.22 98%	3.73 ±.03 90%	3.35 ±.14 86%	3.22 ±.20 77%	2.89 ±.29 77%
Ben	2.95 ±.04 98%	2.89 ±.10 98%	2.92 ±.11 99%	2.88 ±.17 98%	2.77 ±.08 91%	2.51 ±.10 84%	2.34 ±.18 73%	2.03 ±.27 73%
TCE	4.01 ±.08 97%	3.89 ±.10 97%	4.02 ±.11 100%	3.95 ±.14 99%	3.79 ±.07 91%	3.46 ±.14 84%	3.20 ±.29 84%	2.71 ±.39 72%
Tol	3.36 ±.10 96%	3.24 ±.10 96%	3.31 ±.16 99%	3.24 ±.22 96%	3.11 ±.07 89%	2.76 ±.13 84%	2.60 ±.25 84%	2.28 ±.28 73%
PCE	2.44 ±.04 100%	2.43 ±.07 100%	2.46 ±.09 101%	2.41 ±.12 99%	2.33 ±.09 88%	2.04 ±.13 79%	1.84 ±.20 79%	1.55 ±.28 67%
E-Ben	2.86 ±.04 98%	2.80 ±.17 98%	2.87 ±.04 100%	2.74 ±.14 96%	2.69 ±.08 90%	2.44 ±.10 85%	2.28 ±.20 85%	1.99 ±.20 74%
p-Xyl	2.94 ±.07 98%	2.87 ±.10 98%	2.97 ±.12 101%	2.85 ±.18 97%	2.72 ±.08 89%	2.43 ±.14 86%	2.33 ±.18 86%	1.99 ±.25 73%
o-Xyl	3.05 ±.08 95%	2.90 ±.08 95%	3.07 ±.12 101%	3.02 ±.19 99%	2.88 ±.10 90%	2.60 ±.12 89%	2.56 ±.16 89%	2.14 ±.22 74%

*Percent recovery relative to D0 sample concentration.

when using the lower level of analysis in Method 5035, i.e., direct purge-and-trap.

Additional findings unique to the empty VOA vial experiments were that

- Samples analyzed directly by a vapor partition method of analysis failed to achieve quantitative recoveries (Table 8).
- The rate biological degradation appears to increase at lower analyte concentrations (Tables 7 and 8).
- Biological degradation of VOCs appears to be stopped when a soil/water slurry is frozen (Table 8).
- Soil/MeOH slurries show decreasing analyte concentrations with time when held in a VOA vial with a punctured septum (Table 10).

The first observation, and the possibility that the

ability to recover sorbed analytes by direct vapor partitioning methods of analysis may also decrease with the length of storage, is why most studies rely on a MeOH extraction for sample preparation. Experiments designed to assess sample preservation are likely to be confounded by matrix effects when a vapor partitioning method of analysis is used. Therefore the interpretation of the results would be ambiguous, with the possible exception of a study performed with a matrix similar to Ottawa sand (Hewitt 1998b).

Concerning only spiked samples prepared by MeOH extraction, the decreases in analyte concentrations shown for Ben, Tol, E-Ben, and p-Xyl in Tables 7 and 8 show that losses were apparently more rapid at lower analyte concentrations when held at $4 \pm 2^\circ\text{C}$. These compounds decreased by

only 10 to 15% over a week when the concentrations were around 3 mg/kg, while losses of between 35 to 60% occurred in five days when concentrations were some two orders of magnitude lower. This observation suggests that it may be more critical to preserve samples with low levels (less than 0.2 mg/kg) of VOC contamination as compared to those with moderate and high concentrations. Additional supporting evidence for this observation is that experiments performed under similar conditions with this same soil type showed even slower losses when concentrations were around 8 mg/kg (Fig. 2), and were negligible when the total VOC concentrations exceeded 200 mg/kg (Hewitt 1995b).

The results in Table 8 suggest that a slurry composed of 5 mL of water and 5 g of soil held in a 22-mL or larger VOA vial could be frozen as a means to prevent the biological degradation of VOCs. Although vessels filled to less than a third of their total volume did not break when frozen, they were susceptible to breakage under these conditions when vessels were filled to around half full.

The last observation is that once a septum has been punctured, regardless of the presence of MeOH, analytes may diffuse through this breach in the protective layer. Although not shown here, additional studies has shown that this loss mechanism is more prevalent when soil is present. To limit this potential source of error, the needle used to introduce a solution into a sealed VOA vial should be small in diameter, and sample analysis should occur soon (one or two days) thereafter. Furthermore, if these samples are archived, an aliquot of MeOH should either be transferred to an appropriate-sized vessel or the punctured septum should be replaced with one that is intact.

Project data quality objectives should be consulted in addition to experimental findings, such as those presented here, when developing standard operating procedures. The collection, transportation, and storage of samples to be prepared and analyzed for VOCs presents numerous challenges that are seldom rivaled by the other classes of hazardous constituents. Even under the controlled conditions afforded by laboratory experiments the results associated with those VOCs that have high vapor pressures are often less precise and accurate as compared to less volatile analytes. Inspection of the variance in the TDCE concentrations and the values established for this analyte as compared to the spike concentration, shown in Tables 5 and 7, respectively, are examples of this phenomena. For this reason, when the principal

analyte of concern has properties that favor a gaseous state even more so than TDCE (i.e., vinyl chloride) it would be prudent to use even more stringent protocols, i.e., a shorter holding period between collection and analysis.

SUMMARY

Within the last few years, new guidance has come from the U.S. EPA and ASTM with regard to how soil samples acquired for VOC characterization should be collected and handled in preparation for instrumental analysis. The features of this new guidance that will have the greatest impact on improving data quality are the use of less disruptive and fewer transfer steps, and the use of vessels with hermetically sealable closures for transportation and storage. The new measures for sample preservation will also help improve the data quality. To assist with the implementation of this new guidance, two very different protocols have been developed. In one case, all steps leading up to those associated with the analysis process are performed in the field, while the other more traditional approach has all steps associated with sample preparation and analysis occur in a laboratory.

The focus of this report was to evaluate three methods for secure transporting and storing samples so that the laboratory protocol could be used. This study showed core barrel liners wrapped with sheets of Teflon or aluminum foil failed to comply with the intent of this new guidance, i.e., a hermetic seal was not created with respect to the analytes of concern. In contrast, the storage of samples in the En Core sampler or an empty VOA vial was found to be consistent with the intent of the new guidance, and in general 80% or greater of the analyte concentrations were retained over a two-day storage period at $4 \pm 2^\circ\text{C}$. Moreover, after this initial two-day storage period, which corresponds to the length of time currently recommended before samples need to be preserved, samples transferred to a freezer ($-12 \pm 3^\circ\text{C}$) often showed no significant change in concentrations over an additional 12 days of storage. For several reasons, this method of sample preservation appears to be better suited for VOCs in soil matrices than acidification. For instance, acidification is incompatible with carbonates, causes the decomposition of styrene and perhaps other target analytes, and has the potential to cause the formation of acetone. These findings and obser-

vations support the effort to include storage at $-12 \pm 3^\circ\text{C}$ as a method of sample preservation and the use of an empty VOA vial as a transportation and storage vessel, in future revisions of these guidance documents.

LITERATURE CITED

Askari, M.D.F., M.P. Maskarinec, S.M. Smith, P.M. Beam, and C.C. Travis (1996) Effectiveness of purge-and-trap for measurement of volatile organic compounds in aged soils. *Analytical Chemistry*, **68**: 3431–3433.

ASTM D4547-98 (in press) Standard guide for sampling waste and soils for volatile organic compounds. American Society for Testing and Materials.

Bradley, P.M., and F.H. Chapelle (1995) Rapid toluene mineralization by aquifer microorganism at Adak, Alaska: Implication for intrinsic bioremediation in cold environments. *Environmental Science and Technology*, **29**: 2778–2781.

Conant, B.H., R.W. Gillham, and C.A. Mendoza (1996) Vapor transport of trichloroethylene in the unsaturated zone: Field and numerical modeling investigations. *Water Resources Research*, **32**: 9–22.

Hewitt, A.D. (1995a) Enhanced preservation of volatile organic compounds in soil with sodium bisulfate, USA Cold Regions Research and Engineering Laboratory, Special Report 95-26.

Hewitt, A.D. (1995b) Evaluation of methanol and NaHSO_4 for preservation of volatile organic compounds in soil subsamples. *American Environmental Laboratory*, **8**: 16–18.

Hewitt, A.D., and C.L. Grant (1995) Round robin study of performance evaluation soils vapor-fortified with volatile organic compounds. *Environmental Science and Technology*, **29**: 769–774.

Hewitt, A.D., T.F. Jenkins, and C.L. Grant (1995) Collection, handling, and storage: Keys to improved data quality for volatile organic compounds in soil. *American Environmental Laboratory*, **7**: 25–28.

Hewitt, A.D., and N.J.E. Lukash (1996) Obtaining and transferring soils for in-vial analysis of volatile organic compounds. USA Cold Regions Research and Engineering Laboratory, Special Report 96-5.

Hewitt A.D. (1997a) Chemical preservation of volatile organic compounds in soil. *Environmental Science and Technology*, **31**: 67–70

Hewitt, A.D. (1997b) A tool for the collection and storage of soil samples for volatile organic compound analysis. *American Environmental Laboratory*,

9: 14–16.

Hewitt, A.D. (1998a) Laboratory study of VOC partitioning: Vapor/aqueous/soil. USA Cold Regions Research and Engineering Laboratory, Special Report 98-3.

Hewitt A.D. (1998b) Comparison of sample preparation methods for the analysis of volatile organic compounds in soil samples: Solvent extraction vs. vapor partitioning. *Environmental Science and Technology*, **32**: 143–149

Illias, A.M., and C. Jaeger (1993) Evaluation of sampling techniques for the analysis of volatile and total petroleum hydrocarbons (TRPH) by IR, GC, and GC/MS methods. *Hydrocarbon Contaminated Soils*, **3**: 147–165. Chelsea, Michigan: Lewis Publishers.

Lewis, T.E., A.B. Crockett, R.L. Siegrist, and K. Zarrabi (1994) Soil sampling and analysis for volatile organic compounds. *Environmental Monitoring and Assessment*, **30**: 213–246.

Liikala T.L., K.B. Olsen, S.S. Teel, and D.C. Lanigan (1996) Volatile organic compounds: Comparison of two sample collection and preservation methods. *Environmental Science and Technology*, **30** (12): 3441–3447.

Minnich, M.M., J.H. Zimmerman, and B.A. Schumacher (1996) Extraction methods for recovery of volatile organic compounds from fortified, dry soils. *Journal of the Association of Official Analytical Chemists*, **79**: 1198–1204.

Plumb, R.H., Jr., and A.M. Pitchford (1985) Volatile organic scans: Implications for ground water monitoring. In *Proceedings of the National Water Well Association/American Petroleum Institute Conference on Petroleum Hydrocarbons and Organic Chemicals in Ground Water, November 13–15, Houston, Texas.*

Siegrist, R.L., and P.D. Jenssen (1990) Evaluation of sampling method effects on volatile organic compounds measurements in contaminated soils. *Environmental Science and Technology*, **24**: 1387–1392.

Smith J.S., L. Enj, J. Comeau, C. Rose, R.M. Schulte, M.J. Barcelona, K. Kloop, M.J. Pilgrim, M. Minnich, S. Feenstra, M.J. Urban, M.B. Moore, M.P. Maskarinec, R. Siegrist, J. Parr, and R.E. Claff (1996) Volatile organic compounds in soil: Accurate and representative analysis. 3152-4/96/0693, American Chemical Society, p. 693–704.

U.S. Environmental Protection Agency (1986) *Test Methods for Evaluating Solid Waste*. Vol. 1B. SW-846.

Urban, M.J., J.S. Smith, E.K. Schultz, and R.K. Dickinson (1989) Volatile organic analysis for a soil, sediment or waste sample. In *5th Annual Waste Testing & Quality Assurance Symposium*, U.S. Environmental Protection Agency, Washington, D.C., pp. II-87–II-101.

REPORT DOCUMENTATION PAGE

Form Approved
OMB No. 0704-0188

Public reporting burden for this collection of information is estimated to average 1 hour per response, including the time for reviewing instructions, searching existing data sources, gathering and maintaining the data needed, and completing and reviewing the collection of information. Send comments regarding this burden estimate or any other aspect of this collection of information, including suggestion for reducing this burden, to Washington Headquarters Services, Directorate for Information Operations and Reports, 1215 Jefferson Davis Highway, Suite 1204, Arlington, VA 22202-4302, and to the Office of Management and Budget, Paperwork Reduction Project (0704-0188), Washington, DC 20503.

1. AGENCY USE ONLY (Leave blank)		2. REPORT DATE May 1999		3. REPORT TYPE AND DATES COVERED	
4. TITLE AND SUBTITLE Storage and Preservation of Soil Samples for Volatile Organic Compound Analysis				5. FUNDING NUMBERS	
6. AUTHORS Alan D. Hewitt					
7. PERFORMING ORGANIZATION NAME(S) AND ADDRESS(ES) U.S. Army Cold Regions Research and Engineering Laboratory 72 Lyme Road Hanover, New Hampshire 03755				8. PERFORMING ORGANIZATION REPORT NUMBER Special Report 99-5	
9. SPONSORING/MONITORING AGENCY NAME(S) AND ADDRESS(ES) U.S. Army Environmental Center Aberdeen Proving Ground Maryland 21010-5401				10. SPONSORING/MONITORING AGENCY REPORT NUMBER SFIM-AEC-ET-CR-99010	
11. SUPPLEMENTARY NOTES					
12a. DISTRIBUTION/AVAILABILITY STATEMENT Approved for public release; distribution is unlimited. Available from NTIS, Springfield, Virginia 22161				12b. DISTRIBUTION CODE	
13. ABSTRACT (<i>Maximum 200 words</i>) Traditionally, soil samples obtained for characterizing or monitoring sites for volatile organic compounds (VOCs) have been transported off site before initiating the preparation steps necessary for analysis. In the most recent regulatory guidance, only a two-day holding period at $4 \pm 2^{\circ}\text{C}$ is recommended before a sample should be preserved, so as to allow storage up to 14 days prior to instrumental analysis. The transportation and storage of soil samples were evaluated for (1) covered core barrel liners, (2) En Core samplers, and (3) empty volatile organic analysis (VOA) vials under different conditions. Core barrel liners covered with either of two formulations of Teflon sheeting or aluminum foil failed to prevent rapid losses of VOCs. En Core samplers and otherwise empty VOA vials were suitable transportation and storage chambers for samples. These chambers not only meet the initial requirement to retain VOCs for two days when held at $4 \pm 2^{\circ}\text{C}$ for transportation purposes, but frequently showed no significant loss of VOCs after placing in a freezer and storing at $-12 \pm 3^{\circ}\text{C}$ for an additional 12 days.					
14. SUBJECT TERMS		Preservation Soil samples Storage		Volatile organic compounds	
				15. NUMBER OF PAGES 28	
				16. PRICE CODE	
17. SECURITY CLASSIFICATION OF REPORT UNCLASSIFIED	18. SECURITY CLASSIFICATION OF THIS PAGE UNCLASSIFIED	19. SECURITY CLASSIFICATION OF ABSTRACT UNCLASSIFIED	20. LIMITATION OF ABSTRACT UL		