

Special Report 78-14

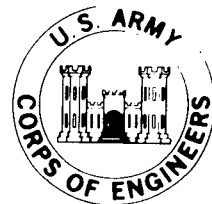

GEOCHEMISTRY OF SUBSEA PERMAFROST AT PRUDHOE BAY, ALASKA

Frederick W. Page and Iskandar K. Iskandar

September 1978

Prepared for
U.S. DEPARTMENT OF COMMERCE
NATIONAL OCEANIC AND ATMOSPHERIC ADMINISTRATION

By



COLD REGIONS RESEARCH AND ENGINEERING LABORATORY
U.S. ARMY CORPS OF ENGINEERS
HANOVER, NEW HAMPSHIRE

REPORT DOCUMENTATION PAGE		READ INSTRUCTIONS BEFORE COMPLETING FORM
1. REPORT NUMBER Special Report 78-14	2. GOVT ACCESSION NO.	3. RECIPIENT'S CATALOG NUMBER
4. TITLE (and Subtitle) GEOCHEMISTRY OF SUBSEA PERMAFROST AT PRUDHOE BAY, ALASKA		5. TYPE OF REPORT & PERIOD COVERED
		6. PERFORMING ORG. REPORT NUMBER
7. AUTHOR(s) Frederick W. Page and Iskandar K. Iskandar		8. CONTRACT OR GRANT NUMBER(s)
9. PERFORMING ORGANIZATION NAME AND ADDRESS U.S. Army Cold Regions Research and Engineering Laboratory Hanover, New Hampshire 03755		10. PROGRAM ELEMENT, PROJECT, TASK AREA & WORK UNIT NUMBERS OCSP0 Order No. 01-5-022-2313
11. CONTROLLING OFFICE NAME AND ADDRESS U.S. Department of Commerce National Oceanic and Atmospheric Administration Boulder, Colorado		12. REPORT DATE September 1978
		13. NUMBER OF PAGES 75
14. MONITORING AGENCY NAME & ADDRESS (if different from Controlling Office)		15. SECURITY CLASS. (of this report) Unclassified
		15a. DECLASSIFICATION/DOWNGRADING SCHEDULE
16. DISTRIBUTION STATEMENT (of this Report) Approved for public release; distribution unlimited.		
17. DISTRIBUTION STATEMENT (of the abstract entered in Block 20, if different from Report)		
18. SUPPLEMENTARY NOTES		
19. KEY WORDS (Continue on reverse side if necessary and identify by block number) Chemical analyses Chemical composition Permafrost Prudhoe Bay, Alaska Subsea permafrost		
20. ABSTRACT (Continue on reverse side if necessary and identify by block number) The analytical data from sediment, interstitial water, and seawater analyses of samples collected near Prudhoe Bay, Alaska, during the period from March to May 1977, are presented. Analyses include determinations of moisture, calcium carbonate, and organic carbon contents in the sediment samples and pH, electrical conductivity, alkalinity, and concentrations of sodium, potassium, calcium, magnesium, chloride, and sulfate in the interstitial water and seawater samples. Salinity, ionic balance, and freezing point of the water samples were		

20. Abstract (cont'd)

calculated. The marine sediments in Prudhoe Bay generally contain more calcium carbonate, organic carbon, and interstitial water than the underlying glacial and fluvial gravels. On land, a surficial layer of peat also had high organic carbon and moisture contents. The salinity of the seawater samples varied from concentrated brines near the shore where sea ice is frozen directly to, or is located near, the sea bottom to water which was 1.0 to 1.5 ppt less saline than normal seawater at a distance of approximately 10 to 15 km from shore.

Potassium, calcium, sulfate, and alkalinity concentrations all showed significant variations from those of normal seawater. The interstitial water samples from sediments taken from the marine boreholes generally contained water whose overall composition was close to that for normal seawater, suggesting that seawater had either infiltrated into, or had been deposited with, the sediments.

Potassium, calcium, alkalinity, sulfate, and magnesium concentrations showed significant variations from those of normal seawater. These variations are thought to be a result of various chemical and biological reactions such as the oxidation of organic matter, ion exchange, weathering of potassium-rich minerals, reduction of sulfate, and the dissolution, precipitation, and/or recrystallization of calcium and/or calcium-magnesium carbonates. On land, the salinity of the interstitial water increased with depth as the composition became progressively more like that of normal seawater. Calculated freezing points, when used in conjunction with temperature data obtainable from the U.S. Geological Survey, indicate that ice-bonded permafrost was encountered at depths of 30.5 and 62 m below the ice surface at distances of 1.0 and 3.2 km from land, respectively. Bonded sediments were also found in the surficial peats on land. In addition, partially frozen sediments were found in sediments located near the sediment/water interface. This zone passed laterally into more bonded sediments closer to shore.

Preface

This report was prepared by Frederick W. Page, Geologist, and Dr. I. K. Iskandar, Research Chemist, of the Earth Sciences Branch, Research Division, U.S. Army Cold Regions Research and Engineering Laboratory (CRREL).

This study was performed under U.S. Department of Commerce, National Oceanic and Atmospheric Administration, Environmental Research Laboratory, Outer Continental Shelf Program Office, Boulder, Colorado; Order No. 01-5-022-2313, 10 February 1977, Delineation and Engineering Characteristics of Permafrost Beneath the Beaufort Sea, Alaska (RU-105).

The technical content of this report was reviewed by Paul V. Sellmann and Edwin J. Chamberlain of CRREL.

The authors would like to thank Dr. Robert C. Reynolds, Jr., Professor of Geology at Dartmouth College, for his comments and encouragement during the period of this study. They are also indebted to Dr. Jerry Brown, of CRREL, for valuable suggestions and for help during the planning of the field portion of the study; to Paul V. Sellmann and Edwin J. Chamberlain, also of CRREL, for collecting the sediment and seawater samples and for providing the results of the grain size analyses; to Dr. David M. Hopkins and Roger Hartz, of the U.S. Geological Survey, Menlo Park, California, for providing copies of the borehole logs; and to Dr. Arthur H. Lachenbruch and B. Vaughn Marshall, also of the U.S. Geological Survey, for permission to use the temperature data.

The contents of this report are not to be used for advertising or promotional purposes. Citation of brand names does not constitute an official endorsement or approval of the use of such commercial products.

CONTENTS

	Page
Abstract	i
Preface	iii
Introduction	1
Site Characteristics	3
Geography	3
Climate	6
Geology	8
Late Quaternary Geological and Climatological History	8
Hydrology	11
Oceanography	11
Sea Ice	14
Sample Collection and Analytical Methodology	15
Sample Collection	15
Sample Preparation and Laboratory Analyses	16
Sediment Analyses	19
Sample Notation	21
Results and Discussion	22
Sediment Characteristics	22
Seawater and Interstitial Water Chemistry	30
Summary and Conclusions	59
Literature Cited	62
Appendix	69

ILLUSTRATIONS

Figure

1. Physiographic units of the North Slope of Alaska.	4
2. Reconstruction of sea-level history for the continental shelf of western and northern Alaska.	10
3. Map of Prudhoe Bay, Alaska, showing locations of sample collection sites.	12
4. Filtering centrifuge apparatus.	17
5. Apparatus used for calcium carbonate determinations.	20
6. Preliminary log of borehole PB5.	22
7. Preliminary log of borehole PB6.	23
8. Preliminary log of borehole PB7.	24
9. Preliminary log of borehole PB8.	25
10. Preliminary log of borehole PB9.	26
11. Temperature and calculated freezing points as a function of depth for borehole PB5.	36
12. Temperature and calculated freezing points as a function of depth for borehole PB6.	37

Figure	Page
13. Temperature and calculated freezing points as a function of depth for borehole PB7.	38
14. Temperature and calculated freezing points as a function of depth for borehole PB8.	39
15. Sodium ion concentration as a function of chloride ion concentration.	43
16. Chloride, sodium, potassium, and salinity as a function of depth for borehole PB8.	51
17. Calcium, magnesium, sulfate, and alkalinity as a function of depth for borehole PB8.	52
18. Conductivity as a function of depth for PB3 and PB7.	57
19. Chloride ion concentration as a function of depth for PB3 and PB7.	58

TABLES

1. Selected sediment characteristics, Prudhoe Bay, Alaska.	27,28
2. Selected interstitial and seawater analyses.	31,32
3. Chemical analyses of interstitial and seawater samples from Prudhoe Bay, Alaska.	40,41
4. Summary of the ionic balances in all interstitial and seawater samples.	42
5. Selected ionic ratios for seawater and interstitial water, by weight.	44,45
6. Summary of the seawater ionic ratios.	46
7. Summary of the interstitial water mean ionic ratios in different holes from Prudhoe Bay, Alaska.	47
8. Seawater ionic concentrations for PB3, PB7, and PB8.	55
9. Interstitial water ionic concentrations and ratios for PB3 and PB7.	56

Introduction

Permafrost is defined as any earth material that is continuously below a temperature of zero degrees Celsius for a period of two or more years (National Academy of Sciences, 1976). This definition is based solely on temperature without regard to the amount or the state of any moisture present, or to the lithologic character of the material. Examples of permafrost could be an ice-bonded sand, a brine-saturated silt, or a cold, dry granite.

Although permafrost is defined on the basis of temperature, researchers have frequently added the terms "ice-bonded" or "ice-rich" to more fully describe the state and amount of the moisture present. Bonded, or ice-bonded, permafrost is material in which the soil particles are bound together by interstitial ice. Ice-rich permafrost denotes material which has a considerable volume of ice. Sediments that contain ice wedges or ice lenses would be examples of the latter type. In recent years, it has also become customary to distinguish between permafrost that exists in the marine environment and that which occurs on land. Terms such as "offshore permafrost" and "subsea permafrost" have been used.

All permafrost can be classified into two types, depending on its equilibrium with its present physical-chemical environment (MacKay, 1972). "Equilibrium permafrost," as its name implies, is permafrost that is in equilibrium with its environment. It is essentially stable in its present spatial distribution. "Disequilibrium permafrost" is not, and it can be further subdivided on the basis of whether it is expanding ("aggrading") or contracting ("degrading") in area or in thickness. A common term for degrading disequilibrium permafrost is the term "relict permafrost." Relict permafrost results when the physical-chemical processes are slow in changing the distribution of permafrost that was formed under a former, more severe climate to its new equilibrium distribution (National Academy of Sciences, 1976).

Since 1968, when oil was discovered at Prudhoe Bay, Alaska, interest in the exploration and development of potential petroleum reserves in the offshore environment has increased. By 1972, results from drilling and geophysical exploration had shown that the prospects of finding oil were excellent. In response to this, the Department of Interior published tentative schedules for leasing offshore lands and, in 1974, the Bureau of Land Management requested that the National Oceanic and Atmospheric Administration (NOAA) initiate an environmental assessment program for the northeastern Gulf of Alaska. This program was expanded in 1975 to encompass other areas of the Alaskan continental shelf including the Beaufort Sea. These studies were

initiated to establish a basis for predicting and assessing the environmental impact of petroleum development.

The objectives of the Outer Continental Shelf Environmental Assessment Program (OCSEAP), as it is called, are the following:

- 1- to describe the distribution and abundance of major biological components of the marine ecosystem for predicting qualitatively the possible impacts of major accidents
- 2- to establish the baseline levels of major contaminants in the natural environment
- 3- to provide improved circulation models for the Alaskan shelf and new insights into the dynamics of ice movement and other pollutant transport mechanisms
- 4- to fill in some of the major gaps in the understanding of the systematic effects of target pollutants on selected arctic and subarctic biota
- and 5- to improve capabilities for assessing hazards that the Alaskan marine environment presents to petroleum development.

It is under this last objective that research on subsea permafrost is being conducted.

Permafrost poses a number of hazards to the exploration and development of petroleum reserves in the offshore environment. Among these are:

- 1- ruptured pipelines and well casings, and damage to drilling and production structures, resulting from the differential freezing and thawing of water in the sediment
- 2- blowouts and fires caused by the presence of "gas hydrates." These solid compounds of gas (mainly methane) and ice produce a sudden evolution of gas upon heating known as a "gas kick." This kick must be contained during drilling operations.
- 3- corrosion and weakening of metals in drilling and production structures, and in pipelines, well casings, etc., due to the concentrated brines often associated with permafrost
- and 4- erroneous interpretation of seismic data due to the increased seismic velocity of ice-bonded

sediments. This may cause offshore production and distribution facilities to be improperly designed.

To help cope with these problems and to form a basis for environmental decisions and regulations, present studies on permafrost are aimed at:

1- developing maps portraying the occurrence of offshore permafrost including the depth to the ice-bonded permafrost table and the thickness of the ice-bonded permafrost layer

2- determining the properties of subsea permafrost including its engineering characteristics

and 3- developing models for predicting the occurrence of both relict and equilibrium permafrost.

This latter objective involves evaluating the relationship between permafrost and various factors including temperature, water and ice content, mass transfer processes such as subsurface fluid migration, sedimentation rates and erosion, past climatological and geological history, terrestrial heat flow, depth of burial, properties of the sediment, and salinity and chemical composition of the interstitial water.

The objectives of the present study are related to these latter two factors, i.e., the salinity and chemical composition of the interstitial water. They are:

1- to define the salinity and chemical composition of the interstitial water in an area where other detailed studies are being conducted. These studies will form a basis for evaluating any models that are developed to predict the occurrence of subsea permafrost

2- to gain insight into the processes which may have affected the chemical composition and salinity of the interstitial water

and 3- to confirm the presence of ice-bonded permafrost in boreholes drilled in Prudhoe Bay.

Site Characteristics

Geography

Prudhoe Bay is located on the northern edge of a tundra known as the Arctic Coastal Plain (Fig. 1). The coastal plain is the northwestern extension of the Interior Plains and extends along the entire coast of the Alaskan Beaufort Sea. It varies in width from less than 20 km at Demarcation

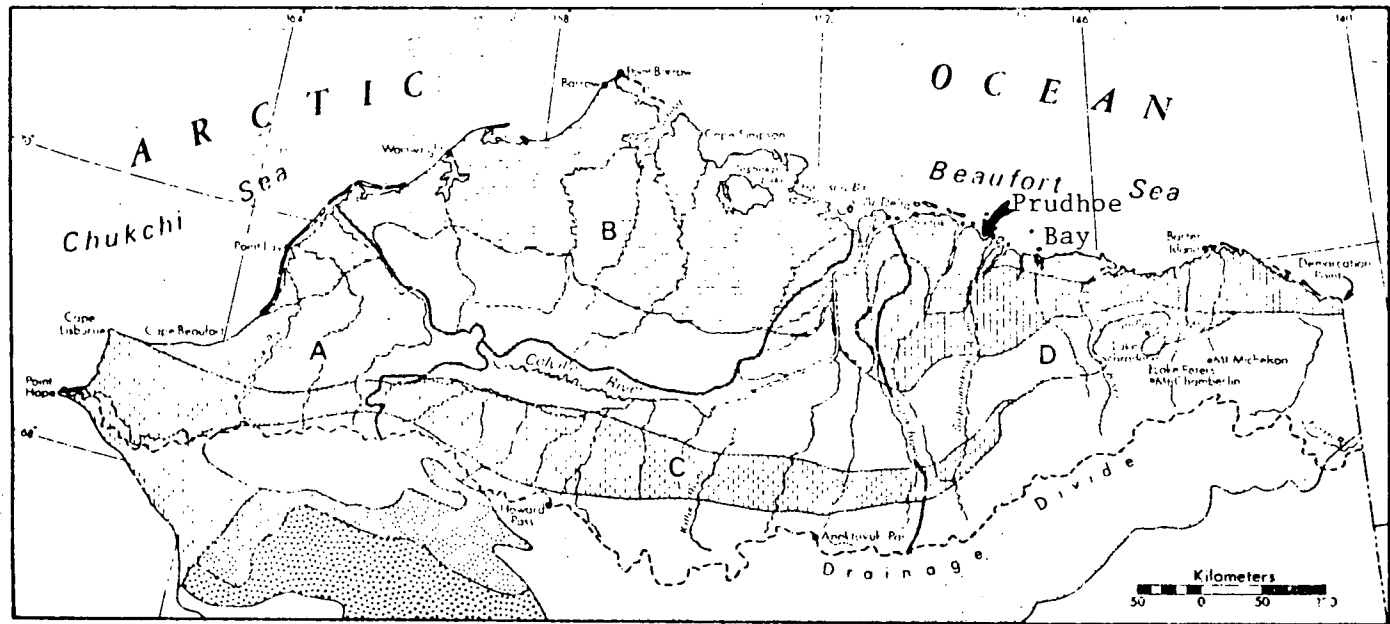

Physiographic Units

Interior Plains
 Arctic Coastal Plains
 Teshekpuk
 White Hills

Rocky Mountains

Arctic Foothills
 Northern Foothills
 Southern Foothills

Arctic Mountains

De Long Mountains
 Nootak Lowlands
 Baird Mountains
 Central and Eastern Brooks Range

Drainage Areas

A — Northwestern
 B — Northern
 C — Colville
 D — Eastern

Figure 1. Physiographic units of the North Slope of Alaska (from Walker, 1974).
 (Copyright, the Arctic Institute of North America; reprinted by permission.)

Point to more than 200 km near Point Barrow (Fig. 1). From the coast, the plain rises gradually to a maximal elevation of approximately 200 m in the south where it borders on the Arctic Foothills. Locally, this boundary is marked by a scarp 15 to 60 m high (Wahrhaftig, 1965).

The coastal plain lies entirely within the zone of continuous permafrost. The permafrost is usually 200 to 300 m thick but may vary in thickness from several tens of meters to more than 600 m, the latter occurring near Prudhoe Bay (Péwé, 1975). The surface of the coastal plain is covered by a nearly continuous network of ice-wedge polygons (Wahrhaftig, 1965) that range in width from several tens of meters to, occasionally, more than 100 m. These polygons are outlined by troughs that are underlain by ice wedges. The ice wedges vary in width from a few centimeters to several meters or more, and in depth from less than a meter to more than 10 m.

Thaw lakes are another common feature of the coastal plain. These lakes form in areas where local thawing of the ice-rich permafrost has caused a subsidence in the surficial topography. The lakes vary in size from ponds a few meters across to lakes more than 40 km in length and are from 1 to 6 m deep. They tend to be oval or rectangular in shape and are generally oriented 15° west of north (Wahrhaftig, 1965).

In addition to the ice-wedge polygons and the thaw lakes, other features associated with the presence of permafrost, such as pingoes, mounds, and drained lake basins, are found on the coastal plain (Péwé, 1975).

The coast of the Arctic Coastal Plain consists of a complex of river estuaries, deltas, bays, barrier island chains, coastal lagoons, and offshore spits (Lewellen, 1974 and Namtvedt et al., 1974). Relief is low to moderate, averaging only 2.8 m, but locally may be 15 m or more. Beaches are narrow, rarely being wider than a few tens of meters, and terminate at the bases of low tundra bluffs consisting of peat, frozen silts, and ice-wedges (Weller et al., 1977). Deltas, consisting of mostly sand and silt, extend seaward from the mouths of major rivers. In the western part of the plain, some of these deltaic sediments have been blown into scattered, longitudinal dunes 3 to 6 m high (Wahrhaftig, 1965).

Seaward of the beaches and deltas, spits or bars are encountered along approximately 40 % of the coast (Short et al., 1974). These range from less than 2 to nearly 10 km in length and are found up to 600 m offshore. Some are migrating westward parallel to the longshore currents. Rates of migration average 14 m/yr but may be as high as 70 m/yr (Namtvedt et al., 1974 and Short et al., 1974).

Farther offshore, barrier island chains are found along approximately 52 % of the coast from Pt. Barrow to Demarcation Pt. (Short et al., 1974). The islands which form the chains are migrating westward at rates varying from 6 to 46 m/yr (Namtvedt et al., 1974 and Short et al., 1974). Some are also moving landward at rates averaging 3 m/yr (Namtvedt et al., 1974). Most of the islands are constructional, being created by ice-push, longshore currents, and wave action. A few, however, are erosional remnants of the mainland (Lewellen, 1972 and 1973; Sellmann et al., 1972; Weller, 1976; and Weller et al., 1977).

Along most of the coast of the Arctic Coastal Plain, the shoreline is retreating at rates averaging 1 to 4 m/yr (Hume et al., 1972 and Lewellen, 1970). This retreat is a result of the high ice content in the sediments that occur along the coastline. In summer, when the coast of the Beaufort Sea is relatively ice-free and temperatures are relatively high, wave action and warm temperatures melt the ice in the coastal sediments, producing thermal erosion. This erosion often undercuts the cliffs, causing large slump blocks to accumulate along the shore (Lewellen, 1970). Every few years, major storms, or storm surges, remove this thawed material and expose fresh ice-rich frozen ground to thermal erosion. The rate of retreat varies, depending on the duration of the ice cover (or open water), water depth, spit protection, barrier island proximity, longshore currents, ice content of the ground (which is often 50 to 75 %), and grain size of the formation being eroded (Lewellen, 1970 and Namtvedt et al., 1974).

When the retreating shoreline breaks into a large thaw lake, such as Teshekpuk Lake (Fig. 1), an embayment is quickly formed, often leaving remnants of the original coastal plain as isolated islands. Prudhoe Bay, Harrison Bay, and Smith Bay are probably examples of former thaw lakes that have subsequently been transformed into marine embayments.

The continental shelf lies seaward of the Arctic Coastal Plain. It is relatively narrow, being only about 50 km wide in the east and 100 km wide in the west. Beyond the shelf's edge, which is usually at a depth of 50 to 70 m, the sea bottom descends rapidly into the Canadian Arctic Basin, at a depth in excess of 3,000 m.

Climate

The Arctic Coastal Plain is located in an Arctic climate zone. Temperatures range from a maximum of 26°C to a minimum of -55°C, but average on an annual basis between -8 and -14°C (Brown et al., 1975; Namtvedt et al., 1974; and Péwé, 1975). July and August are the two warmest months, having mean monthly temperatures of 4.3°C and 3.0°C,

respectively (Namtvedt et al., 1974). Freezing temperatures and/or snow can occur at any time. In winter, temperatures average -26 to -36°C (Namtvedt et al., 1974) and strong thermal inversions, often 1200 to 1500 m deep, exist over the snow and ice cover.

Precipitation along the Arctic coast is low, averaging only 10 to 20 cm/yr (Namtvedt et al., 1974; Péwé, 1975; and Wahrhaftig, 1965). Most of the precipitation (roughly 80 %) falls during the period from June to November, with July and August having the highest mean monthly precipitation. These are also the months with the highest mean monthly temperatures and the largest open water areas. Only about 20 % of the precipitation falls from December to May which can be attributed to the lack of open water areas and to the inability of cold air to hold much moisture (low absolute humidity).

Beginning in mid-September, snow begins to predominate the precipitation, establishing a snow cover over most of the coastal plain. This snow gradually deepens during the winter and by March or April is from 30 to 70 cm thick (Namtvedt et al., 1974). However, persistent winds may cause high areas to be essentially free of snow, whereas low-lying areas may have more than 2 m of snow (Sellmann et al., 1972). In late spring, the snow cover begins to melt and usually disappears by late June or July (Namtvedt et al., 1974).

Winds along the coast of the Beaufort Sea are dominated by the Polar High (Sellmann et al., 1972). They have a dominant east-northeast component resulting from the deflection of cold polar air masses by Coriolis forces. In the summer, cyclonic low pressure cells also cause southwesterly winds to frequently occur. Because of the low relief on the coastal plain and the low-lying tundra vegetation, winds near the surface are generally strong and constant, blowing at an average speed of 12 km/hr (Weller, 1976). Calm conditions are rare, occurring only 1.3 % of the time near Pt. Barrow (Namtvedt et al., 1974).

In summer, when ice-free conditions exist along the coast, strong winds and storms associated with low pressure systems can cause large fluctuations in sea level known as storm surges. These surges can cause sea level to rise more than 1.5 m for periods of several days. One of the largest storm surges occurred in October of 1963 when sea level rose 3.6 m and inundated large areas of land near Pt. Barrow (Hume and Schalk, 1967). Another large storm surge occurred in September of 1970 in the southern Beaufort Sea (Reimnitz et al., 1972). These meteorological fluctuations in sea level are often larger than the normal lunar tides of 15 to 30 cm (Namtvedt et al., 1974 and Sellmann et al., 1972), and are a major factor in causing coastal erosion and retreat.

They remove old slumped materials from the base of the coastal tundra bluffs and expose fresh ice-rich sediments to thermal erosion.

Geology

Most of the Arctic Coastal Plain consists of a thin veneer of unconsolidated sediments known as the Gubik Formation (Black, 1964). The Gubik Formation is from 0 to 60 m thick and is divided into three units. The Barrow unit consists of a poorly sorted to well-sorted mixture of clay, silt, sand, and gravel that contains abundant amounts of ice and peat. It is mostly marine, but locally may be fluvial or lacustrine in origin. Underlying, and in part contemporaneous with, the Barrow unit is the Meade River unit. It consists of a clean, well-sorted, marine silty sand that was probably deposited during the Mid-Wisconsin interstadial. The lowermost unit of the Gubik Formation is the Skull Cliff unit. It consists of a poorly sorted, blue-black to dark gray deposit of clay, silt, sand, and cobbles and was probably deposited during either the Sangamon interglacial or the Illinoian glaciation.

In the eastern part of the Arctic Coastal Plain, the Gubik Formation is underlain by an early Tertiary deposit of terrestrial red beds known as the Sagavanirktok Formation (Payne et al., 1951). These sediments consist of poorly consolidated conglomerates, sandstones, and siltstones and obtain a maximal thickness of 1,500 m near Prudhoe Bay. They were deposited during the early Tertiary as a result of orogenic activity (Laramide Orogeny) in the Brooks Range.

Under both the Gubik and Sagavanirktok Formations are thick deposits of Mesozoic shales and sandy shales with interbeds of graywacke sandstones and volcanic tuffs. These deposits outcrop in the Arctic Foothills and in the Brooks Range along with Paleozoic limestones, shales, and sandstones.

Late Quaternary Geological and Climatological History

Around 100,000 years B.P. (before present), a major climatic warming occurred which brought about the end of the Illinoian glaciation. This warm period, known as the Sangamon interglacial, lasted until approximately 70,000 years B.P. when the Wisconsin glaciation began. During the warm interval, glaciers retreated, forests expanded into areas that were previously unforested, and permafrost thawed in many of the southern areas of Alaska. In northern Alaska, however, the moderating influence of a maritime environment probably prevented substantial thawing from occurring (Gold and Lachenbruch, 1973). Sea level rose to a maximal level of 10 m above the present-day mean sea level,

inundating large areas of land. During this "Pelukian transgression" (Hopkins, 1967), marine sediments were deposited in many of the low-lying areas of the Arctic Coastal Plain. These sediments contain the remains of marine organisms now found only in more southern latitudes, suggesting that the seas were warmer during the Sangamon interglacial than they are today.

After the Sangamon interglacial, the climate became cool once again and the Wisconsin period of glaciation began. Two major glacial advances took place. The first of these lasted from about 70,000 to approximately 35,000 years B.P. and is known as the Sagavanirktok glaciation (Hamilton and Porter, 1975). The second, known as the Itkillik I glaciation, lasted from roughly 25,000 to 14,000 years B.P. During both of these periods, glaciation was limited to a series of valley and piedmont glaciers that occupied portions of the Brooks Range and the northern Arctic Foothills. Even though some of these glaciers extended up to 50 km beyond the front of the Brooks Range, the Arctic Coastal Plain remained unglaciated throughout the Wisconsin.

Between the Sagavanirktok and the Itkillik I periods of glacial activity, a relatively warm period, or interstadial, occurred. During this time, sea level rose to a level that was 20 to 25 m below present-day mean sea level (Weller et al., 1977; Fig. 2). Hopkins (1967) has referred to this rise in sea level as the "Woronzofian transgression," although the name should probably be dropped because the type locality that he used to describe this transgression has since been shown to be much younger than Mid-Wisconsin in age (Péwé, 1975).

During Mid-Wisconsin time, the Flaxman Formation was deposited (Leffingwell, 1908 and 1919 and MacCarthy, 1958). This formation consists mostly of striated, faceted boulders that are found up to 14 km inland and at elevations not exceeding 7.5 m. The boulders are composed of quartzite, greenstone, granite, limestone, diabase, quartz diabase, and basalt, rock types which are not found among the glacial tills bordering the Brooks Range. Leffingwell (1919) concluded that the boulders were morainic material that had been ice-rafted to the Arctic Coastal Plain from one or more source areas located somewhere to the east.

Because the boulders are found up to 7.5 m above present-day mean sea level, it is inferred that a broad, regional uplift has occurred since the Mid-Wisconsin interstadial (McCulloch, 1967). The shallowness of the continental shelf (less than 70 m) and the presence of Pleistocene beach lines inland support this hypothesis.

At the end of the Mid-Wisconsin interstadial, the Itkillik I period of glaciation occurred during which time

sea level fell to approximately 100 m below present-day mean sea level (Fig. 2). This glaciation culminated about 16,000 years B.P., and was followed by glacial retreat, rapidly rising seas, and one major glacial advance, the Itkillik II, at about 11,000 to 12,500 years B.P. (Hamilton and Porter, 1975).

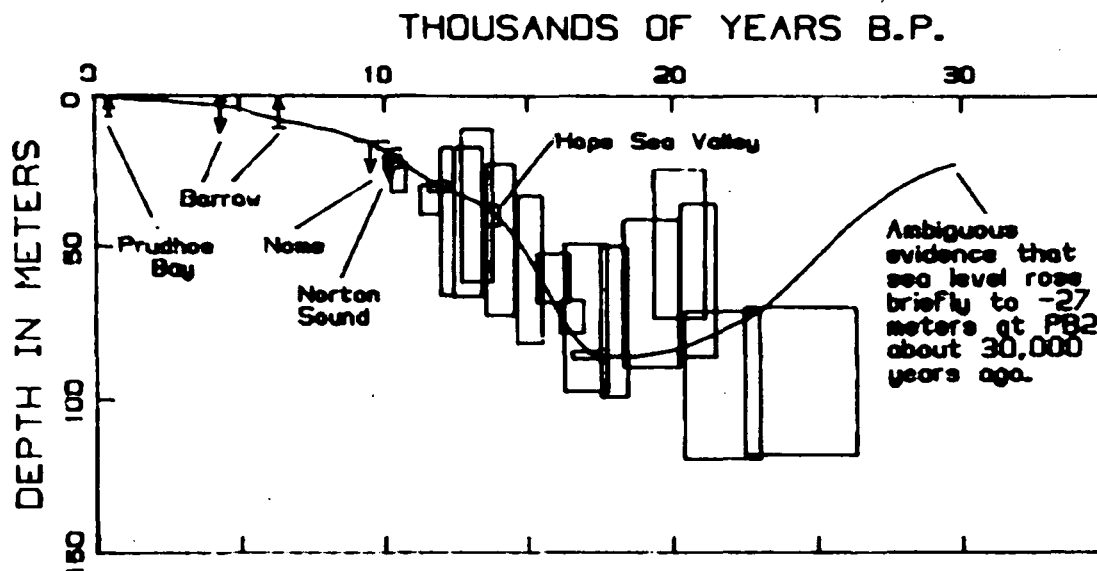

Figure 2. Reconstruction of sea-level history for the continental shelf of western and northern Alaska. Width of boxes indicates uncertainty of age and height indicates uncertainty of position of sea level. Down-pointing arrows mark maximum possible position of sea level whereas up-pointing arrows mark minimum possible position of sea level. After Hopkins in Beaufort Sea Synthesis Report, Weller et al., editors, 1977.

Beginning around 10,000 or 11,000 years B.P., a worldwide climatic warming occurred which brought about the end of the Pleistocene. Glaciers experienced rapid retreat except for 4 brief cold periods during which they advanced. These minor advances (along with their approximate dates) were the Itkillik III glaciation (8,300 to 6,300 years B.P.), the Alapah Mountain glaciation (3,500 to 2,700 years B.P.), the Fan Mountain Stage I glaciation (1,500 to 1,200 years B.P.), and the Fan Mountain Stage II glaciation (900 to 200 years B.P.) (Hamilton and Porter, 1975). During early to mid-Holocene time, sea level continued to rise (the "Krusternian transgression" of Hopkins, 1967) until about 4,000 to 5,000 years B.P., when it reached a level near today's mean sea level (Fig. 2). Since that time, sea level has oscillated within 1 to 2 m of present-day mean sea level, in response to the brief periods of glaciation and the intervening warm periods.

Hydrology

The Arctic Coastal Plain is crossed by a number of rivers which sluggishly make their way from the Brooks Range in the south northward to the Beaufort Sea. The largest of these rivers is the Colville River with a length of 640 km and a drainage area of 61,440 km² (Namtvedt et al., 1974). To the west of the Colville River, rivers generally meander in incised valleys 15 to 90 m deep (Wahrhaftig, 1965), whereas those to the east tend to run more in braided streams. Most of the rivers have very low gradients, and are probably not transporting sediment any coarser than sand-sized grains at the present time.

Two of the larger rivers are found in the vicinity of Prudhoe Bay. The closest of these is the Sagavanirktok River, which lies 1 to 2 km to the east (Fig. 3). It is the second largest river on the coastal plain with a length of 266 km and a drainage area of 14,198 km² (Namtvedt et al., 1974). The other river, the Kuparuk River, is 14 km to the west of Prudhoe Bay. It empties directly into Gwyder Bay and probably does not influence Prudhoe Bay.

During winter, most of the rivers along the Beaufort Sea are frozen to the bottom and, consequently, do not discharge water into the sea (Walker, 1974). In spring, however, rising air temperatures and longer days begin to melt the seasonal snow cover, initiating the process of river breakup. Peak flows usually occur sometime in late May and last only about two weeks (Walker, 1974).

Near the coast, discharging river water initially flows over the nearshore, bottom-fast sea ice, inundating it to a depth of up to 1.5 m and seaward for distances of up to 10 km or more (Reimnitz and Bruder, 1972 and Walker, 1974). As the fresh water reaches holes and cracks in the ice, it drains through them, creating depressions in the sediments beneath the ice. These depressions may be more than 4 m deep and tens of meters across (Reimnitz et al., 1974). Above them are the drainage holes. These holes may be up to 30 m wide and usually have feeder channels radiating from them. After several days, an area of open water begins to develop around the distributary mouths and the river water flows directly into the sea.

Oceanography

Off the coast of the Arctic Coastal Plain lies a subdivision of the Arctic Ocean known as the Beaufort Sea. This sea extends approximately from Pt. Barrow in the west to Banks Island in the east. Water in the Beaufort Sea can be subdivided into four water masses, each with its own characteristic temperature, salinity, currents, and depth (O'Rourke, 1974). The deepest water is known as "Arctic

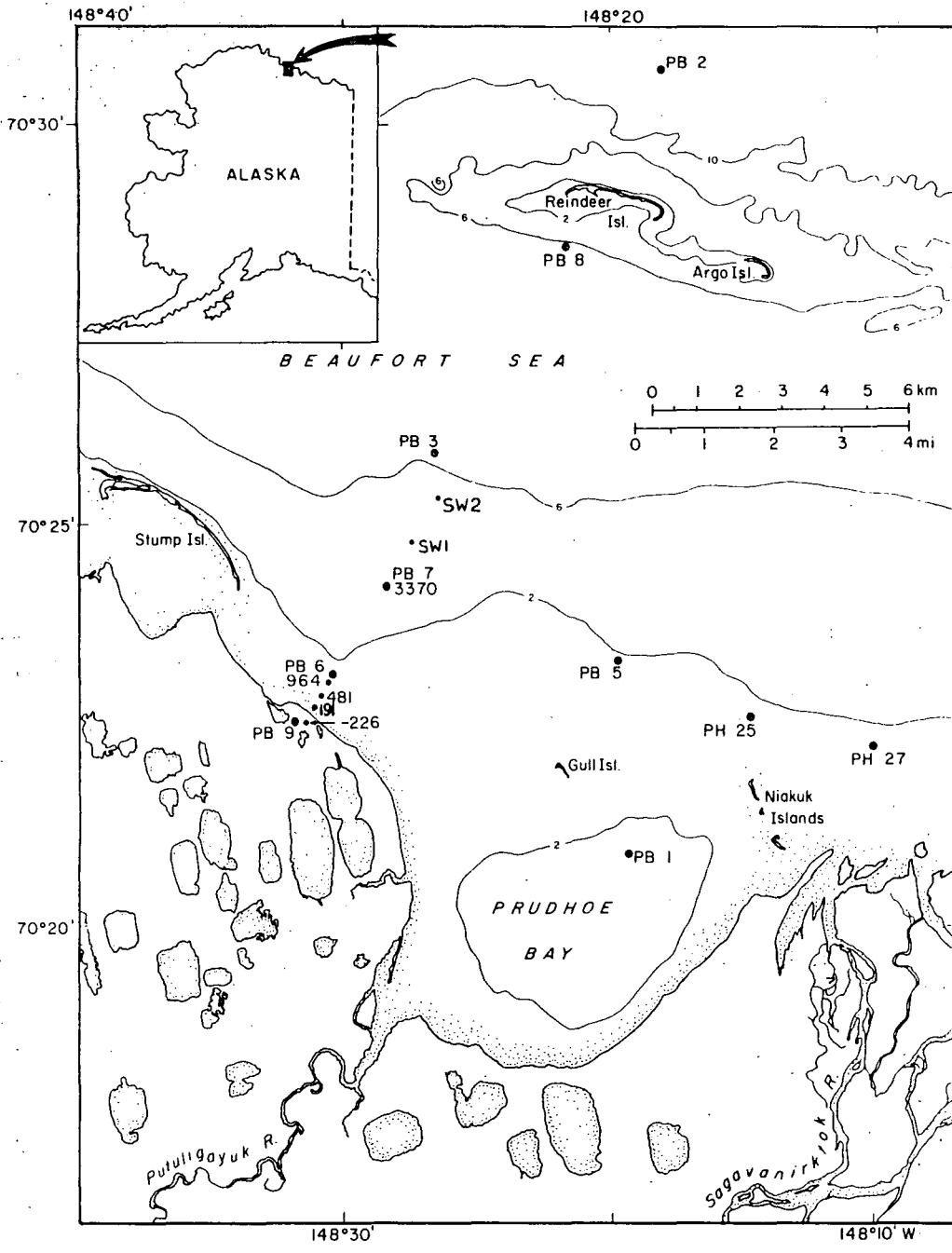

Figure 3. Map of Prudhoe Bay, Alaska, showing locations of sample collection sites. PB1-3 are from Iskandar et al. (in press); -226, 191, 481, 964, and 3370 are from Osterkamp and Harrison (1976); and PB5-9, PH25, and PH27 are holes drilled and sampled during the spring of 1977. Depth contours are in meters below mean sea level.

bottom water" and is found at depths in excess of 900 m. It has a year-round temperature ranging from 0.0 to -0.4°C and a salinity of 34.9 to 35.0 parts per thousand (ppt). Near the continental slope, the water generally flows to the west at velocities of less than 3 cm/sec (0.11 km/hr).

Above the Arctic bottom water is a water mass believed to originate in the Atlantic Ocean. This "Atlantic water" (O'Rourke, 1974) flows in through the gap between Spitzbergen and Greenland and is found at a depth of 250 to 900 m. Year-round temperatures range from 0.0 to 0.5°C and salinity is generally 34.5 to 35.0 ppt. Currents in the Atlantic water are similar to the Arctic bottom water, being westerly at less than 3 cm/sec (0.11 km/hr).

Above both the Atlantic water and the Arctic bottom water is a water mass with characteristics that are much more complex than the two previously described. This "Arctic Ocean water" (O'Rourke, 1974) is subdivided into a "surface layer" and a "subsurface layer." The surface layer is generally found in the upper 15 to 50 m of the water column and is characterized by seasonal variations in temperature and salinity. The largest variations occur during the summer and are due to local differences in river runoff, solar radiation, ice melt, and wind-induced mixing. Temperature and salinity may vary from -1.6 to 15°C and from 1.5 to 32.6 ppt, respectively. Usually, the higher temperatures and lower salinities are due to local river runoff and occur only in the nearshore areas, at depths of less than 5 m. Currents in the surface layer are also more variable during the summer (or ice-free) months than at other times of the year. In nearshore areas, currents are largely wind-induced and water may be flowing in any direction at velocities ranging from 0 to 60 cm/sec (0.0 to 2.2 km/hr) (Hufford, 1974). Seaward of the continental shelf, the surface layer is influenced by the Pacific, or Beaufort, Gyral. Water generally flows in a westerly direction at velocities of up to 60 cm/sec (2.2 km/hr).

During winter, both temperature and salinity in the surface layer are more uniform due to the presence of an ice cover and the lack of runoff from rivers. Temperatures are usually -1 to -2°C whereas salinities may vary from 30 to 34 ppt. In the nearshore areas, however, temperatures as low as -12°C and salinities as high as 182.8 ppt have been encountered (Schell, 1973). These low temperatures and high salinities are found in brines which evolve during winter as a result of the formation of sea ice.

The subsurface layer is located between the surface layer and the Atlantic water and originates through the mixing of surface runoff with Atlantic water off the Siberian shelf (O'Rourke, 1974). Year-round temperatures vary from -1.2 to -1.8°C whereas salinities range from about 32.0 to 34.5 ppt.

Currents generally follow the Pacific Gyral, moving westward as speeds ranging up to 60 cm/sec (2.2 km/hr).

Finally, there is a water mass located near the edge of the continental shelf which originates through the advection of water from the Bering and/or Chukchi Seas. This water mass consists of three layers: a surface layer (0 to 50 m in depth) of relatively warm (0.0 to 7.3°C), fresh (28.5 to 32.5 ppt) water; a middle layer (50 to 100 m in depth) of cooler (-1.2 to 0.1°C), more saline (33.0 to 34.5 ppt) water; and a bottom layer (100 to 200 m in depth) of cold (-1.4 to -1.6°C), saline (34.9 to 35.0 ppt) water (Hufford, 1973 and 1974; Mountain, 1974; and O'Rourke, 1974). The latter is also characterized by a nutrient maximum. All of these layers flow eastward, at rates varying between 5 and 100 cm/sec (0.2 to 3.6 km/hr) (Kovacs and Mellor, 1974 and Mountain, 1974), and have been traced as far as Barter Island near the Canadian border.

Sea Ice

For nine months of the year, the Beaufort Sea is covered by sea ice. This ice exerts a profound influence on the structure of the sediments, the rate of coastal retreat, and the salinity and temperature of the water. Sea ice usually forms in early October and increases in thickness throughout the winter. Maximal thicknesses of 1.8 to 2.1 m occur in March or April (Kovacs and Mellor, 1974).

Beginning in late spring, the ice begins to diminish in both area and thickness. Breakup is initiated when rivers along the coast flood the estuarine sea ice. Drainage holes develop and areas of open water are created in front of the distributary mouths (Reimnitz and Bruder, 1972). Two weeks later, puddles begin to appear on the surface of the ice. These gradually coalesce and are responsible for reactivating old fractures. In late June, openings in the ice appear, and usually by late July, most of the coast is ice-free (Namtvedt et al., 1974; Sellmann et al., 1972; Short and Wiseman, 1975; and Weller et al., 1977).

During the winter, ice nearest the shore is relatively stable and is known as "fast ice." Fast ice may be frozen directly to the bottom ("bottom-fast ice"), or floating ("floating fast ice"), depending on the depth of the water column and the thickness of the ice (Kovacs and Mellor, 1974 and Namtvedt et al., 1974). Movement in this ice is small, usually from a few meters to as much as tens of meters in areas of floating fast ice, and generally occurs early in its formation.

Seaward of the fast ice is a narrow zone of pressure ridges. These ridges are usually from 2 to 10 m high and are formed when moving pack ice shears against the

stationary fast ice. The location of the shear zone varies and is dependent on the depth of the water column, the time of the year, and the protection afforded by barrier islands and offshore bars (Kovacs and Mellor, 1974).

Beneath each of the pressure ridges is a keel, 5 to 18 m in depth. These keels often become grounded and create gouge furrows in the sediment which may be more than 1 m in depth (Barnes and Reimnitz, 1974 and Kovacs and Mellor, 1974). Similar furrows are created inshore of the shear zone by small ice blocks as well as seaward of the pressure ridges by larger ice masses. This scoring action by keels and other ice masses disturbs or obliterates the sedimentary structures and it has been estimated that, in the vicinity of the shear zone, bottom sediments are completely reworked to a depth of 30 cm once every 50 years (Weller et al., 1977).

Beyond the shear zone is the seasonal pack ice. This ice extends outward 100 to 200 km to the edge of the polar pack ice. The seasonal pack ice contains relatively mobile first-year ice which drifts westward in response to geostrophic winds and currents. Rates of movement average 20 km per month in winter and 80 to 100 km per month in summer (Weller et al., 1977). The position of the pack ice relative to the land is quite variable and is largely dependent on the winds. In winter, strong winds may produce leads in the ice which may be more than 30 km wide. In summer, they may cause the pack ice to be either close to shore or more than 100 km away (Kovacs and Mellor, 1974 and Namtvedt et al., 1974).

Rare features in the seasonal pack ice are ice islands. These large pieces of shelf ice make their way from Ellesmere Island into the Pacific Gyral and down along the coast of the Beaufort Sea. Typically, they are 10 to 30 m thick and 30 to 100 m across (Kovacs and Mellor, 1974 and Namtvedt et al., 1974). Some may be as small as 10 m in width, whereas others may be as large as 0.8 by 2.4 km. Ice islands are most frequently encountered seaward of the 20-m isobath. Where they become grounded, they can score the bottom in the same manner as pressure-ridge keels do. Ice gouge marks are typically 0.5 to 2 m deep, and can be up to 30 m wide and 3 to 5 km long.

Sample Collection and Analytical Methodology

Sample Collection

During the spring (March 22 to May 5) of 1977, a joint drilling program was undertaken by personnel from the U.S. Army Cold Regions Research and Engineering Laboratory (CRREL), Hanover, N.H.; the U.S. Geological Survey, Menlo Park, California; and by Dr. Robert I. Lewellen, an arctic

consultant. Samples were collected at five drill hole and two probe hole sites located within Prudhoe Bay (Sellmann et al., 1977) (Fig. 3). The sites were located using standard surveying techniques.

Drilling was accomplished using heavy duty (4.5-in, 11.4-cm OD), flush-jointed casing that was driven by a McKiernan-Terry Model #5 air pile hammer. Air was supplied by a Davey air compressor capable of delivering 7 m³ of air per minute at a pressure of 7 kg/cm². Samples were collected at various intervals, using either a Washington sampler (Diamond Drill Contracting Company) or a Lynac drive sampler. The Washington sampler worked well in fine-grained material, providing relatively undisturbed cores 5 cm in diameter and up to 60 cm in length. The Lynac sampler was used for more coarse-grained material. It was outfitted with a four-spring core catcher and a rubber sleeve to prevent loss of material during retrieval. Both samplers had ball check valves in the upper end of the barrels which helped to prevent contamination from the seawater in the hole. Once a sample was recovered, it was photographed, logged, and then subsampled for use in engineering property determinations, chemical analysis, and geological studies including paleontological and carbon-14 analyses. The chemistry samples were packed in insulated boxes and were shipped as soon as possible to the CRREL field office in Fairbanks, Alaska.

Following the completion of each drill hole, a 5-cm plastic (PVC) casing was installed and filled with a non-freezing liquid. Temperature measurements were made over a period of several weeks using a thermistor probe. Preliminary logs were prepared based on the cores and wash samples from each hole.

Sample Preparation and Laboratory Analyses

As samples were received from the field, they were placed in a refrigerator until such time as moisture content, pH, alkalinity, and conductivity analyses could be conducted. Interstitial water was extracted from the sediment samples, using special filtering centrifuge tubes (Millipore Corporation Model XX62-025-50, shown in Fig. 4). Each sample was centrifuged at 2,000 rpm for 15 minutes. The extracted water was decanted into glass vials and was analyzed for pH, alkalinity, and conductivity.

Following centrifugation, each sediment sample was dried in an oven set at 60°C and the total moisture content was calculated on a percentage dry weight basis. Accuracy of these determinations varied with the grain size of the material. Values for fine-grained materials are probably accurate to within 1%. However, the interstitial water in coarse-grained materials tended to drain from them prior to

centrifugation. As a result, moisture content determinations for these materials are probably too low.

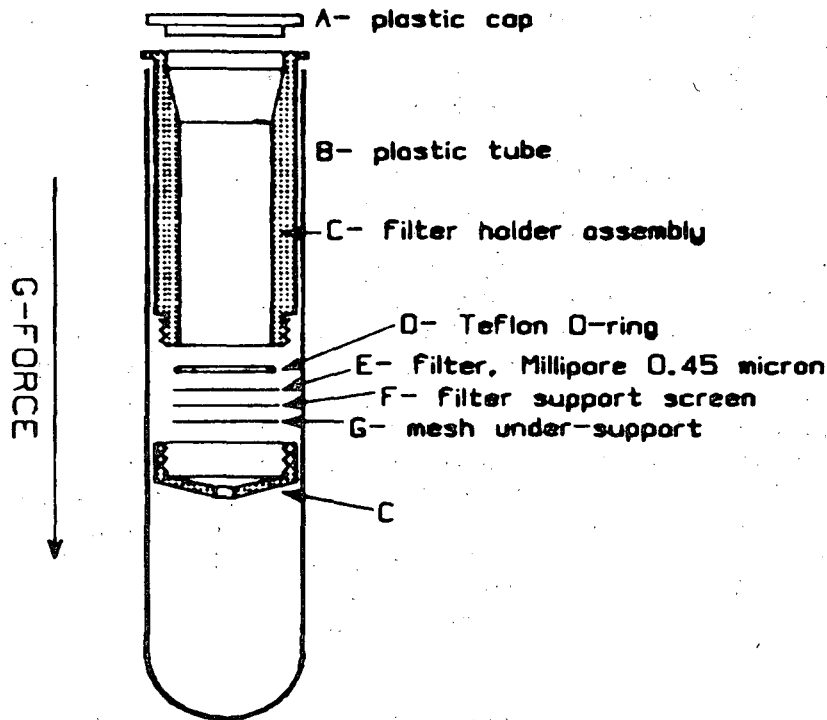

Figure 4. Filtering centrifuge apparatus.

Hydrogen ion activity (pH) was measured on all seawater and interstitial water samples using a semi-micro Ag/AgCl combination electrode (Corning Scientific Instruments # 476050) connected to a portable pH meter (Orion Portable Model 407A). The calibration was checked frequently, using commercially prepared pH 7.00 and pH 8.00 buffers. Accuracy of these measurements was ± 0.2 of a pH unit.

Conductivity was measured using a conductivity bridge (Industrial Instruments, Inc. Model RC-216B2J) and a glass pipette conductivity cell (cell constant 1.0). The cell constant was checked regularly, using carefully prepared potassium chloride solutions of known conductivity (Lind et al., 1959), and was found to range from 1.014 to 1.044. Temperatures were measured to the nearest tenth of a degree ($^{\circ}\text{C}$) using a copper-constantan thermocouple and a digital thermometer (John Fluke Manufacturing Company, Inc. Type T Digital Thermometer). This system was checked using a certified mercury thermometer in both water and ice-water baths and its measurements were found to be both accurate and reproducible to at least 0.1°C . All conductivity measurements were standardized to 25°C using the formula

$$[0.02 \times (25 - t)]$$

$$K(25) = p \times K(t) \times e$$

where $K(25)$ is the conductivity at 25°C , $K(t)$ is the conductivity at temperature t , p is the cell constant, e is the base for natural logarithms (2.71828), and 0.02 is an approximation of the temperature coefficient. Precision of the conductivity measurements averaged better than 1 %. Accuracy, in some cases, was considerably worse.

Most of the conductivity measurements for the interstitial and seawater samples were made with a large resistor placed between the poles of the conductivity instrument. For these values, accuracy is estimated at 2 to 3 %. However, for the interstitial water samples from PB8, the resistor was removed. Initially, it was thought to have no effect on the measurements because the cell constant did not change. However, the conductivities for PB8 are from 5 to 15 % lower than would be expected based on the sodium and chloride ion concentrations. Therefore, the conductivity data for PB8 should only be used to indicate relative concentrations of ions. (Note: Errors in the conductivity measurements for PB8 did not affect the salinity determinations as the latter were calculated based on the concentrations of the individual ions and not on the conductivity data).

Alkalinity was measured by potentiometric titration of a 1-ml sample with a 0.001 N hydrochloric acid solution. The procedure is given on p. 55 in Standard Methods for the Examination of Water and Wastewater [American Public Health Association (APHA), 1971]. Known solutions of sodium carbonate were used to standardize the normality of the acid. Alkalinity values were calculated as parts per thousand (ppt) bicarbonate and are believed to be accurate to within 5 %.

All of the above analyses were performed in the CRREL laboratory in Fairbanks, Alaska. Samples were then shipped to Hanover, N.H., where the following analyses were done on the interstitial water, seawater, and sediment samples.

Chloride ion concentrations were measured using a modified version of the Argentometric Method as outlined in Standard Methods for the Examination of Water and Wastewater (APHA, 1971; p. 96, Procedure 112A). Normally, a 1-ml sample was titrated with a more dilute silver nitrate solution than is called for in the procedure. The silver nitrate solution was standardized daily using a sodium chloride solution. Precision was better than 1 %, whereas accuracy was believed to be within 3 %.

Sulfate was measured using a modified version of the procedure given in Scheide and Durst (1977). The method

determines sulfate by titration with lead nitrate in an 80 % isopropanol solution. A lead specific ion electrode (Orion Model 94-82) connected to a digital pH-mV meter (Orion Model 801A) is used to determine the end point. The procedure was modified to include a strip chart recorder (Hewlett-Packard Model 7100B) and a constant delivery tubing pump (Sage Instruments Model 375A). The pump was found to have an extremely constant delivery rate, varying only 0.02 % between replicate samples. Samples were placed in a Teflon beaker with a sodium chloride ionic strength adjustor. The original procedure had called for a potassium nitrate ionic strength adjustor, but it was found that a precipitate formed when this solution was added. This precipitate may have been potassium sulfate because it disappeared when the solution was titrated with lead nitrate. To prevent a precipitate from forming, a sodium chloride solution was used which worked satisfactorily.

After a sample was placed in the Teflon container, the magnetic stirrer and tubing pump were started. The time was noted on the strip chart recorder by momentarily flicking the pH-mV switch to pH mode on the digital meter. The titration was run until an "S"-shaped curve was produced on the strip chart recorder. The end point was taken to be the point of steepest slope and the time of the end point was noted. Standards were run and a best fit straight line was determined. It was observed that the standards deviated from this line at concentrations in excess of 200 parts per million of sulfate ion. The unknown concentrations were calculated and are believed to be accurate to within 7 or 8 %.

Sodium, potassium, calcium, and magnesium ions were determined using an atomic adsorption spectrophotometer (Perkin Elmer Model 303). Each sample was diluted to the appropriate range and analyzed. Lanthanum oxide, dissolved in dilute hydrochloric acid, was added to the calcium and magnesium dilutions prior to analysis. Precision was better than ± 3 % for the sodium, calcium, and magnesium analyses, and better than ± 4 % for the potassium analyses. Accuracy is generally believed to be within 5 %.

Sediment Analyses

Sediment analyses included the determination of calcium carbonate and organic carbon. Calcium carbonate was determined by measuring the volume of carbon dioxide gas evolved when hydrochloric acid (1:3) was added to a preweighed sediment sample (Fig. 5). A thin film of oil was added to both the reservoir and the beaker to prevent the carbon dioxide gas from dissolving into the water and to prevent evaporation. Standards of reagent grade calcium carbonate were run and the resulting calibration curve was used to calculate the percentage calcium carbonate.

Precision was generally \pm 1 to 2 %, whereas accuracy was thought to be about 5 %.

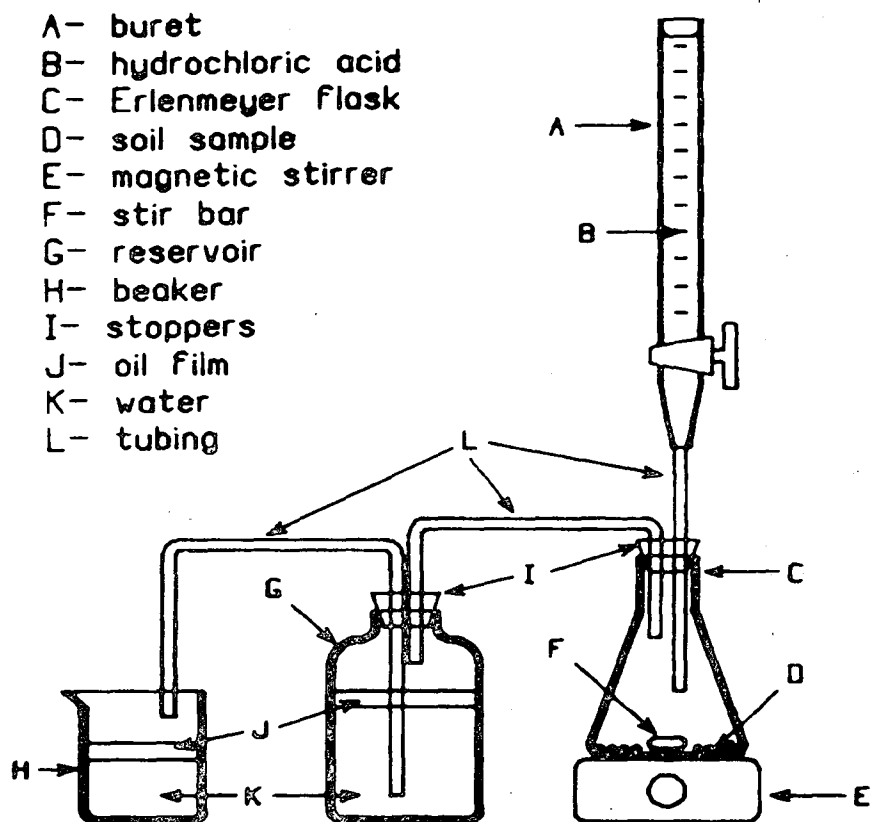

Figure 5. Apparatus used for calcium carbonate determinations.

Organic carbon was measured using a modification of the Walkley and Black (1934) method that is described in Bremner and Jenkinson (1960). The reaction is based on the wet chemical oxidation of organic carbon using a mixture of potassium dichromate and concentrated sulfuric acid. At the end of the digestion period, the amount of remaining potassium dichromate is determined by titration with a 1 N ferrous sulfate solution and an indicator solution of barium chloride and barium diphenylamine sulfonate. The percentage of organic carbon was calculated on the basis that, for every 1 ml of 1 N potassium dichromate solution consumed, 3 mg of organic carbon were oxidized. Computed values have a precision of better than \pm 0.1 % organic carbon, whereas the accuracy is probably slightly worse due to variability in subsampling the sediments.

Grain size distributions were determined by Chamberlain (personal communication, 1977), using standard sieve and hydrometer methods (Richards, 1954). From these data, the percentage of silt and clay and the textural classification

of the sediments (Shepard, 1954) were determined. Gross mineralogy of some of the sediments was also determined, using standard X-ray diffraction techniques.

Sample Notation

Samples are labelled using one of the following formats: PB(?) WC-?), PB(?) WS-?), PH(?) WC-?), or SW(?) WS-?). Those samples prefixed by PB were collected at one of the five boreholes drilled during the spring of 1977. The samples were either seawater samples (WS) or sediment samples (WC). Those samples prefixed by PH were sediment samples (WC) which were collected at probe hole sites. Finally, several seawater samples were collected at two stations which were neither probe hole nor borehole sites. These are designated by the format SW(?) WS-?).

Results and Discussion

Sediment Characteristics

Lithology and Stratigraphy

Figures 6-10 are summaries of the preliminary logs for each of the boreholes drilled during the spring of 1977. Each figure contains a brief description of the sediments, an interpretation of their depositional environment, and the positions of the samples used in this study. The location of each borehole is given in Sellmann et al. (1977) and is shown in Figure 3.

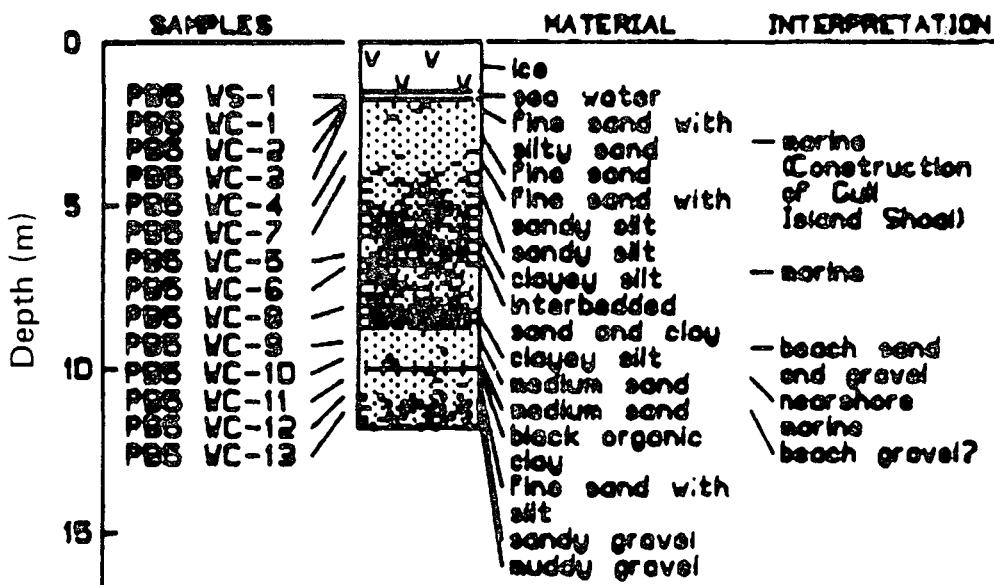

Figure 6. Preliminary log of borehole PB5 (Courtesy of Dr. D.M. Hopkins, and Roger Hartz, U.S.G.S.).

All of the boreholes are similar in their general stratigraphic sequence. The sediments at and just below the sea bed surface consist of fine sands and silty sands. These marine deposits are thickest near the shore (PB6) and where shoals are being constructed (PB5). Further seaward, the sands are thinner and contain proportionately more silt and clay. Underlying these sands and silty sands is a layer of marine silts and clays. These fine-grained deposits reach a maximal thickness of 14 m at PB8, but thin towards the shore, being almost totally absent at PB6. Below the marine sands and muds is a former beach deposit consisting of well-rounded sands and gravels. On land (PB9), the marine deposits are absent and in their place are ice-bonded peats, silts, and sands.

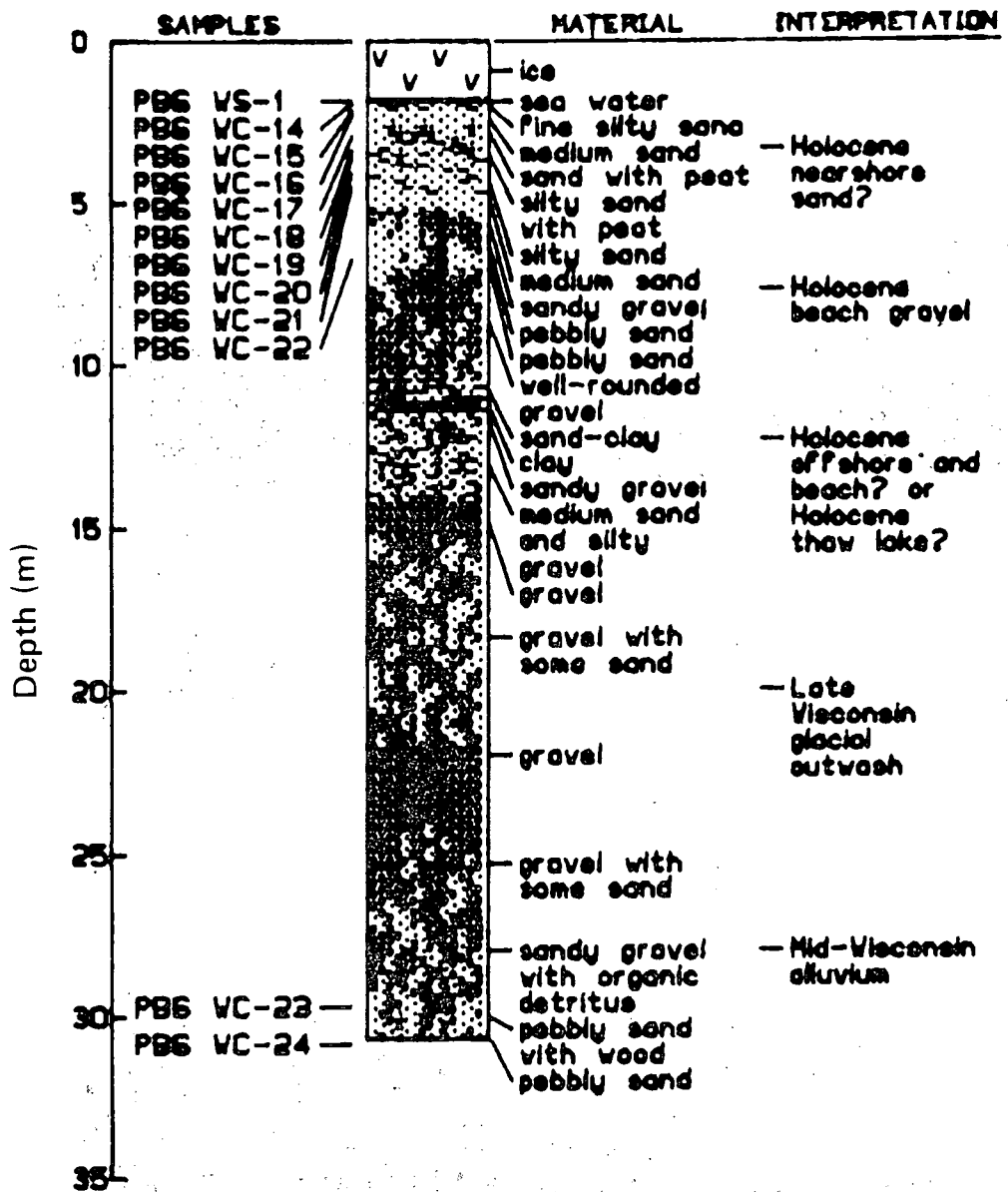

Figure 7. Preliminary log of borehole PB6 (Courtesy of Dr. D.M. Hopkins, and Roger Hartz, U.S.G.S.).

Below the marine sediments of PB5-8 and the ice-bonded sands of PB9 are clean, sandy gravels. These gravels are a Late-Wisconsin glacial outwash deposit and are underlain by a Mid-Wisconsin alluvium. The latter contains gravels, sands, and organic detritus.

Moisture Content

Table 1 presents the results of the sediment analyses. Sediment texture and percentage of clay and silt generally reflect the position of a sample in the stratigraphic sequence described above and will not be discussed further.

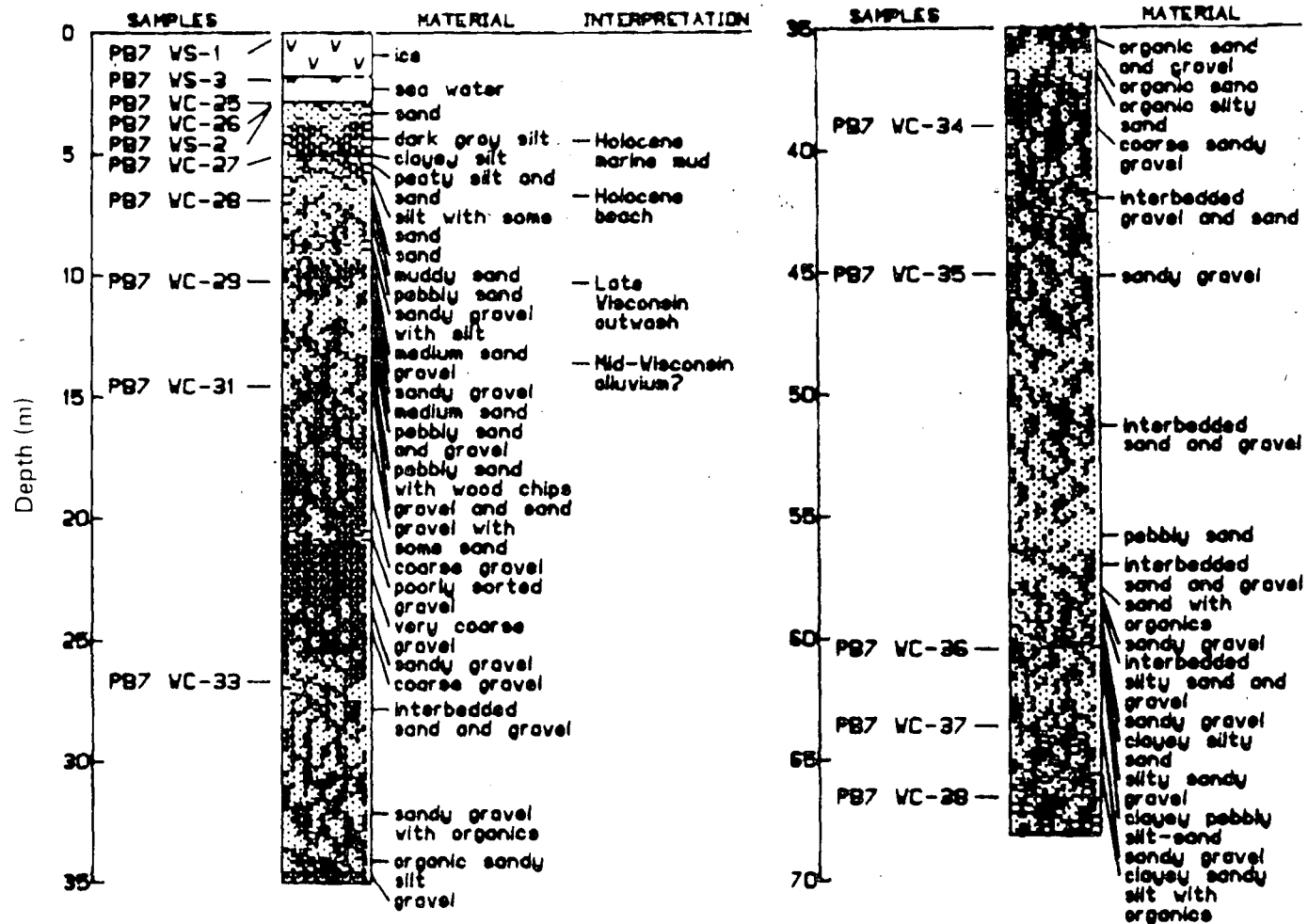

Figure 8. Preliminary log of borehole PB7 (Courtesy of Dr. D.M. Hopkins, and Roger Hartz, U.S.G.S.).

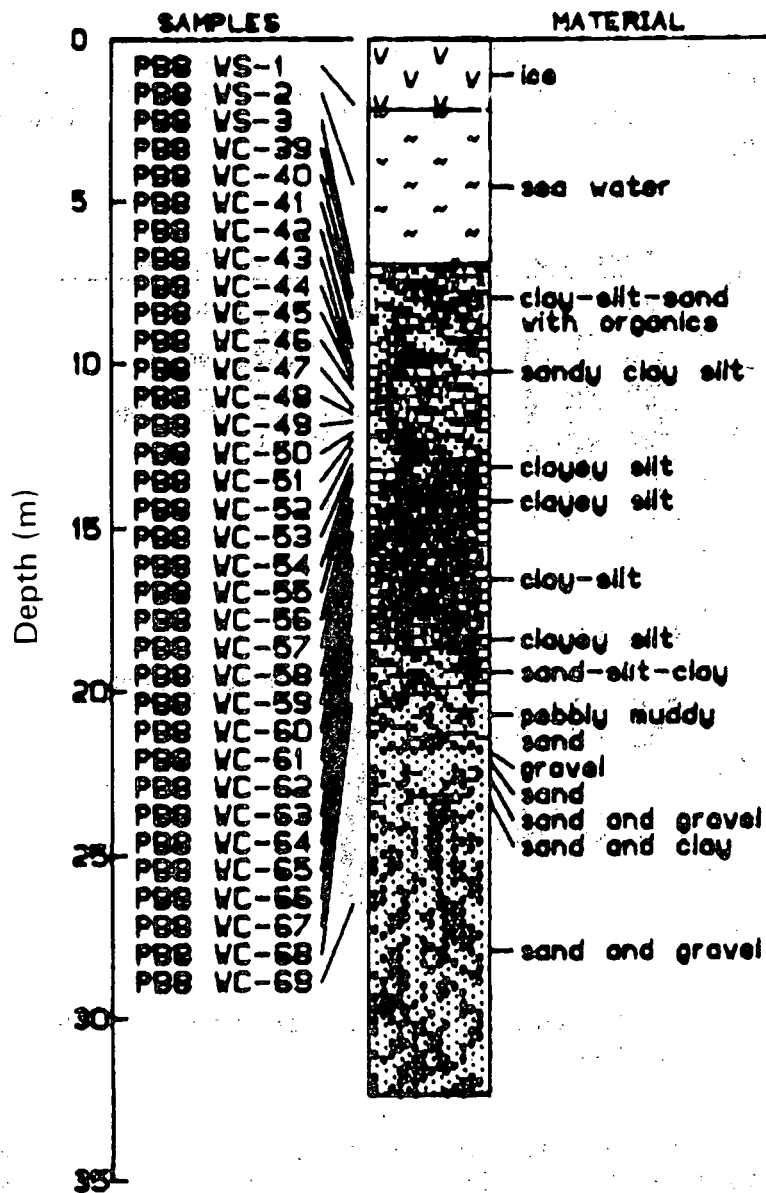

Figure 9. Preliminary log of borehole PB8 (Courtesy of Dr. D.M. Hopkins, and Roger Hartz, U.S.G.S.).

Total water contents for all sediment samples ranged from 4.8 to 485.5 % on a dry weight basis. With the exception of the very high values, the results agree well with those obtained from other Prudhoe Bay marine sediments by Osterkamp and Harrison (1976), Iskandar et al. (1978), and Chamberlain (personal communication, 1977). Chamberlain's values were particularly important because his moisture determinations were done on samples which came from the same cores as the chemistry samples. Generally, his analyses agreed to within +1 to 2 % with the data presented here. The highest moisture contents (59.6 to 485.5 % on a dry weight basis) were found on land (PB9), where ice crystals

and ice lenses were observed in some organic-rich silts (peats). Similar findings have been published by Brown (1969) and O'Sullivan (1963) for soils collected near Barrow, Alaska.

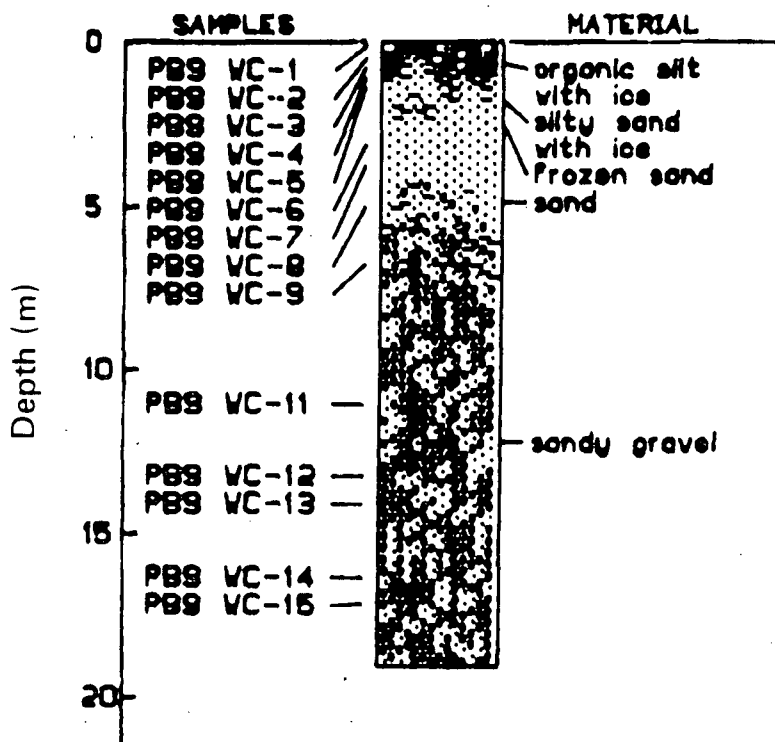

Figure 10. Preliminary log of borehole PB9. (Hole drilled by R&M Engineering).

Except for the ice-rich peats of PB9, all other sediments contained less than 45 % (dry weight) water. Generally, the fine-grained sediments contained more water than did the coarser grained material. For example, clays and silts usually contained 20 to 45 % water on a dry weight basis, whereas sands contained 10 to 20 % and gravels less than 10 %. This distribution with grain size may have been the result of a higher porosity in the clays and silts or may have been due to the partial drainage of the interstitial water from the coarser grained materials prior to analysis. Sands and gravels have lower surface tensions than either silt or clay and, therefore, tended to allow the interstitial water to drain more easily from the pore spaces. This surface tension effect also explains why proportionately smaller amounts of extractable water were obtained from the clays and silts than from either the sands or gravels.

Table 1. Selected sediment characteristics, Prudhoe Bay, Alaska.

1 SAMPLE	2 DEPTH	3 Sediment Texture	4 % Clay and Silt	5 Ex- tract- able Water	6 Total Water	7 Calcium Car- bonate	8 Organic Carbon
PB5 WC-1	1.80			18.9	25.9	30.01	0.12
PB5 WC-2	1.94			21.8	29.3	26.43	0.17
PB5 WC-3	2.16			9.4	25.5	29.03	0.46
PB5 WC-4	3.34	sandy silt	58	15.0	38.8	24.96	1.48
PB5 WC-5	6.50	sandy silt	82	7.1	29.6	29.44	0.80
PB5 WC-6	6.90	clayey silt	86	6.2	40.0	28.28	1.15
PB5 WC-7	4.10	sandy silt	65	8.0	28.6	29.70	0.69
PB5 WC-8	8.11	clayey silt	98	4.9	36.9	31.80	1.19
PB5 WC-9	9.20	sand	8	14.0	18.7	11.52	0.07
PB5 WC-10	9.70	sand	9	12.2	18.9	22.82	0.18
PB5 WC-11	10.35			14.1	21.6	29.23	0.13
PB5 WC-12	10.85	gravel	9	1.6	4.8	6.41	0.08
PB5 WC-13	11.33	gravel	16	1.4	4.8	12.37	0.05
PB6 WC-14	1.90			13.9	36.0	23.28	1.78
PB6 WC-15	2.15			13.9	40.2	22.62	1.72
PB6 WC-16	2.30			13.6	20.9	11.11	0.27
PB6 WC-17	2.93			5.2	13.7	16.89	0.13
PB6 WC-18	3.40	silty sand	29	2.0	12.8	24.21	0.26
PB6 WC-19	3.63			3.2	14.5	12.75	1.37
PB6 WC-20	4.10			9.2	15.3	12.46	0.12
PB6 WC-21	4.56			1.5	13.4	16.34	0.37
PB6 WC-22	6.79	pebbly sand	6	6.1	9.1	4.24	0.06
PB6 WC-23	29.72			3.8	6.8	0.53	0.08
PB6 WC-24	30.87			6.5	10.2	0.38	0.11
PB7 WC-25	2.91			25.6	42.9	26.78	1.06
PB7 WC-26	3.03			19.1	27.4	30.31	0.23
PB7 WC-27	5.15			12.5	30.3	24.52	0.74
PB7 WC-28	6.92			2.9	11.9	26.70	0.16
PB7 WC-29	10.25			4.1	6.9	3.55	0.05
PB7 WC-31	14.56	gravel	19	3.9	6.2	2.10	0.04
PB7 WC-33	26.70			3.4	6.3	1.01	0.11
PB7 WC-34	38.98			6.0	8.9	0.44	0.10
PB7 WC-35	45.07			2.8	5.8	0.89	0.28
PB7 WC-36	60.45			1.6	10.0	1.12	0.46
PB7 WC-37	63.60			4.2	7.8	0.49	0.21
PB7 WC-38	66.56			1.1	26.7	3.63	3.03
PB8 WC-39	7.22			4.0	26.4	20.80	0.76
PB8 WC-40	7.97	silt, sand	58	3.1	23.8	21.62	0.72
PB8 WC-41	8.62			4.8	21.2	23.55	0.49
PB8 WC-42	9.47	clayey silt	86	1.5	26.9	20.60	1.11
PB8 WC-43	10.08			3.4	34.8	18.22	0.65
PB8 WC-44	10.27	sandy clay-silt	80	6.9	23.6	25.83	0.44
PB8 WC-45	10.48	sand-clay-silt	72	5.6	22.0	24.74	0.46
PB8 WC-46	10.82			3.4	19.9	23.52	0.44
PB8 WC-47	11.37			3.2	27.3	21.44	1.88
PB8 WC-48	11.54	sand-clay-silt	76	0.9	21.9	19.99	0.85
PB8 WC-49	11.81	sand-clay-silt	68	0.5	15.8	21.00	0.48
PB8 WC-50	12.16			2.3	19.2	20.90	0.44
PB8 WC-51	12.35	sand-clay-silt	75	3.5	21.2	23.20	0.52
PB8 WC-52	12.63			2.2	32.7	18.07	0.99
PB8 WC-53	13.12	clayey silt	98	1.5	30.9	21.03	1.20
PB8 WC-54	13.38	clayey silt	87	5.3	36.2	18.60	1.08
PB8 WC-55	13.59			2.5	38.4	19.36	1.52

Table 1 continued.

1 SAMPLE	2 DEPTH	3 Sediment Texture	4 Clay and Silt	Ex- tract- able Water	4 Total Water	5 Calcium Car- bonate	5 Organic Carbon
PB8 WC-56	14.23			2.5	43.0	19.37	1.32
PB8 WC-57	14.55	clayey silt	99	2.2	35.4	20.16	1.38
PB8 WC-58	15.24			2.8	34.9	19.72	1.43
PB8 WC-59	15.33	clayey silt	98	2.7	39.2	16.43	1.28
PB8 WC-60	15.90	silty clay	100	1.1	32.5	13.68	1.65
PB8 WC-61	16.13			0.5	31.8	11.57	1.56
PB8 WC-62	16.68			0.2	29.5	12.51	1.48
PB8 WC-63	16.99	silty clay	100	2.7	44.7	11.32	1.70
PB8 WC-64	17.61			1.0	33.2	11.29	1.48
PB8 WC-65	18.40	clayey silt	90	0.2	26.1	14.19	1.49
PB8 WC-66	18.86			1.2	28.2	13.25	1.70
PB8 WC-67	19.30			3.1	17.8	5.86	0.50
PB8 WC-68	20.44			10.7	15.5	14.48	0.10
PB8 WC-69	26.55			2.0	6.0	1.52	0.27
PH25 WC-2	2.30			15.2	44.9	24.76	1.84
PH25 WC-5	2.68			13.3	38.4	26.15	1.25
PH27 WC-1	1.95			15.3	26.5	29.92	0.25
PH27 WC-3	2.17			18.8	30.0	26.43	0.40
PH27 WC-5	2.37			11.2	27.2	28.67	0.78
PB9 WC-1A	0.15			24.5	89.1	1.34	11.29
PB9 WC-1B	0.15			5.4	59.6	5.98	7.68
PB9 WC-2A	0.46			50.8	98.8	8.03	3.40
PB9 WC-2B	0.46			420.3	485.5	8.79	6.88
PB9 WC-2C	0.46			420.3	485.5	5.61	8.88
PB9 WC-3A	0.76			107.1	166.8	7.03	12.08
PB9 WC-3B	0.76			107.1	166.8	7.05	12.92
PB9 WC-4A	1.07			67.7	130.7	8.19	12.11
PB9 WC-4B	1.07			67.7	130.7	7.37	11.91
PB9 WC-4C	1.07			67.7	130.7	5.92	5.02
PB9 WC-5A	1.37			55.8	94.0	5.96	8.16
PB9 WC-5B	1.37			55.8	94.0	6.77	8.76
PB9 WC-6A	3.12			20.1	24.1	5.61	0.07
PB9 WC-6B	3.12			20.1	24.1	5.76	0.04
PB9 WC-7	3.73			15.2	19.3	5.18	0.07
PB9 WC-8A	5.03			2.6	8.5	2.66	0.05
PB9 WC-8B	5.03			2.6	9.2	2.60	0.06
PB9 WC-9A	6.78			0.4	7.4	1.80	0.09
PB9 WC-9B	6.78			2.3	6.6	2.13	0.08
PB9 WC-11	11.05			2.4	5.1	1.75	0.05
PB9 WC-12	13.26			4.1	9.7	2.85	0.08
PB9 WC-13	14.10			3.7	8.2	4.50	0.12
PB9 WC-14	16.31			0.9	5.4	2.90	0.07
PB9 WC-15	17.14			2.0	8.4	1.56	0.14

1

"PB" is borehole number, "PH" is probe hole number, and "WC" is sediment sample number

2

in meters below sea ice surface

3

after Shepard (1954)

4

in grams per 100 grams dry weight

5

in percent dry weight

Calcium Carbonate Content

In general, the marine sediments from boreholes PB5-8 were highly calcareous whereas the underlying gravels and the sediments from the hole drilled on land (PB9) were not. Calcium carbonate percentages for all of the sediments ranged from 0.38 to 31.80 (Table 1). The highest values (25 to 32 %) were found in the marine sands and muds of PB5, PB7, PH25, and PH27. Interestingly, all of these stations are near the 2-m isobath (Fig. 3), suggesting that the high percentages of calcium carbonate may be due to the precipitation of calcium carbonate from brines which form during the freezing of seawater. Both seaward and landward of this line of stations, values decreased to less than 26 %. In the gravels underlying the marine muds and in the peats of PB9, calcium carbonate contents were generally less than 10 %.

The above findings are in general agreement with other studies. Iskandar et al. (1978), for example, reported ranges of calcium carbonate of 15.5 to 21.3, 8.9 to 14.8, and 13.9 to 27.5 % for the marine muds of PB1, PB2, and PB3, respectively. These stations are located near PB5-8 (Fig. 3). Corresponding values for the gravels ranged from less than 0.1 to 9.3 %. Similar ranges of 1.5 to 28.69 % (Naidu and Mowatt, 1973) and 2.67 to 22.38 % (Burrell et al., 1973) have been reported for other areas of the continental shelf. Naidu and Mowatt (1973 and 1974) have also categorized the calcium carbonate measurements by environment. Lagoons, for example, averaged between 18.9 and 20.1 %, whereas open marine sediments averaged between 12.0 and 12.5 %. These averages compare well with data from PB1, PB3, PB6, and PB8, and PB2, respectively.

Organic Carbon Content

Organic carbon contents in the sediments ranged from 0.04 to 12.92 % (Table 1). The highest values (3.40 to 12.92 %) were found on land, in the upper 1.5 m of PB9 where sediments contained abundant amounts of peat. Similar high values have been reported by Brown (1969) and O'Sullivan (1963) for some peats at Barrow, Alaska. Under the peaty layer, the sands and gravels were almost totally devoid of organic matter, containing less than 0.15 % organic carbon (cf. Schell, 1973).

In the marine boreholes, the organic carbon content is much lower, ranging from 0.04 to 3.03 %. Generally, the higher values are found in the marine silts and clays, whereas the underlying gravels contain less than 0.5 %. However, wash samples showed that some zones in the sandy gravels contained interbedded silty sand with large quantities of woody material. This would explain why the highest value (3.03 %) was found at the bottom of PB7, in

the Mid-Wisconsin alluvium.

Other investigators have reported similar findings. Chamberlain (personal communication, 1977), for example, reported a range of 0.24 to 3.10 % for samples that were taken from the same cores as the chemistry samples. His values were particularly interesting because he used the combustion method to determine the organic carbon content. Iskandar et al. (1978) reported values (for PBl-3) ranging from 0.12 to 3.15 % organic carbon in the marine sediments whereas the underlying gravels contained less than 1.08 %. Naidu and Mowatt (1974) have published average values for the surficial sediments in various environments. Lagoons, for example, have an average value of 0.93 % organic carbon. Other environments (with their corresponding percentages) include bays (0.73 %), open marine (0.81 %), and the nondeltaic Beaufort Sea shelf (1.12 %). These low organic carbon contents suggest that organic detritus from rivers and shoreline erosion may not be an important factor in the overall organic carbon budget.

Seawater and Interstitial Water Chemistry

pH

The pH data (Table 2) show that seawater during the spring of 1977 had a relatively uniform pH, varying from 7.7 to 8.0. In the sediments, however, pH was more variable, ranging from 7.05 to 8.4. This latter range is similar to the ranges reported by Iskandar et al. (1978) for sediments from PBl-3 (7.3 to 7.95), by Siever et al. (1965) for various oceanic sedimentary environments (7.0 to 7.85), and by Presley and Kaplan (1968) for sediments off the southern California coast (7.5 to 8.0). In Prudhoe Bay, pH shows a weak tendency for slightly higher values in the marine muds (7.9 to 8.4) than in either the underlying gravels (7.8 to 8.1) or the more sandy sediments located near the sea bed surface (7.5 to 7.9). These latter sediments are probably influenced by the lower pH's of the overlying seawater.

On land, pH values were lower (7.3 to 8.2) in the upper 2 m of PB9 than in the underlying sands and gravels (7.8 to 8.4). These lower pH's are probably due to the presence of organic acids derived from the abundant peats in this upper layer of sediment.

Salinity and Conductivity

Assuming that most of the interstitial water samples have compositions similar to the composition of seawater, salinity may be calculated in two ways. The first is to sum up all of the cations and anions. In this summation, only one-half of the bicarbonate ion concentration should be included. The reason for this is shown by the following

Table 2. Selected interstitial and seawater analyses.

1	2		3	4	Salinity (after UNESCO, 1966)	5	6
SAMPLE	DEPTH	pH	Conductivity	Salinity	UNESCO, 1966)	Calculated Freezing Point	Ionic Balance
PB5 WC-1	1.80	7.66	57.06	40.06	41.48	-2.11	2.07
PB5 WC-2	1.94	7.86	55.60	39.28	39.63	-2.07	2.83
PB5 WC-3	2.16	7.90	49.51	34.71	34.96	-1.83	0.96
PB5 WC-4	3.34	7.89	49.09	33.98	35.26	-1.80	1.11
PB5 WC-5	6.50	8.17	50.80	34.97	35.86	-1.85	2.01
PB5 WC-6	6.90	8.23	51.12	35.86	36.10	-1.89	0.51
PB5 WC-7	4.10	8.09	49.59	33.46	35.26	-1.77	-1.87
PB5 WC-8	8.11	8.30	52.07	37.98	38.01	-2.00	1.13
PB5 WC-9	9.20	8.10	51.25	35.81	37.17	-1.89	1.27
PB5 WC-10	9.70	8.15	49.99	35.04	35.83	-1.85	2.28
PB5 WC-11	10.35	8.18	51.04	35.32	36.57	-1.86	1.53
PB5 WC-12	10.85	8.26	59.47	42.14	43.03	-2.22	2.32
PB5 WC-13	11.33	7.94	58.28	42.06	42.80	-2.21	3.14
PB6 WC-14	1.90	7.70	66.20	47.51	48.24	-2.49	1.91
PB6 WC-15	2.15	7.54	45.83	31.89	31.00	-1.69	7.13
PB6 WC-16	2.30	7.73	57.35	40.44	40.60	-2.13	1.62
PB6 WC-17	2.93	7.59	62.23	45.62	46.18	-2.39	1.48
PB6 WC-18	3.40	7.96	63.44	46.05	44.83	-2.42	4.49
PB6 WC-19	3.63	8.05	62.69	45.17	44.87	-2.37	3.32
PB6 WC-20	4.10	7.75	62.39	44.04	45.05	-2.31	1.71
PB6 WC-21	4.56	8.02	65.84	55.87	56.55	-2.92	3.86
PB6 WC-22	6.79	7.80	77.07	56.13	58.59	-2.93	2.58
PB6 WC-23	29.72	7.34	50.23	35.94	37.11	-1.90	0.91
PB6 WC-24	30.87	7.05	60.04	43.70	46.00	-2.30	2.61
PB7 WC-25	2.91	7.67	47.12	32.62	32.73	-1.73	0.58
PB7 WC-26	3.03	7.91	47.15	32.67	33.09	-1.73	0.48
PB7 WC-27	5.15	8.06	53.38	37.98	37.89	-2.00	0.70
PB7 WC-28	6.92	8.12	54.25	37.69	38.42	-1.99	1.46
PB7 WC-29	10.25	8.11	53.74	37.93	38.84	-2.00	1.35
PB7 WC-31	14.56	8.14	55.94	39.74	40.57	-2.09	1.03
PB7 WC-33	26.70	8.04	57.56	41.21	41.82	-2.17	0.56
PB7 WC-34	38.98	7.99	53.95	38.78	38.84	-2.04	1.45
PB7 WC-35	45.07	8.00	56.42	40.29	40.93	-2.12	1.70
PB7 WC-36	60.45	8.01	61.06	44.50	45.05	-2.34	1.47
PB7 WC-37	63.60	7.90	55.66	40.03	40.51	-2.11	1.03
PB7 WC-38	66.56		58.04	42.68	43.57	-2.24	0.96
PB8 WC-39	7.22	7.81	46.86	32.30	32.22	-1.71	1.17
PB8 WC-40	7.97	8.01	47.04	31.57	31.77	-1.67	1.24
PB8 WC-41	8.62	8.10	37.08	31.76	32.22	-1.68	0.03
PB8 WC-42	9.47		41.77	30.50	31.49	-1.62	0.89
PB8 WC-43	10.08	8.29	41.24	30.82	31.31	-1.63	-0.01
PB8 WC-44	10.27	8.05	41.83	30.59	31.59	-1.62	-0.60
PB8 WC-45	10.48	8.30	40.80	31.40	31.44	-1.66	-1.45
PB8 WC-46	10.82	8.20	42.48	30.15	31.16	-1.60	-0.41
PB8 WC-47	11.37	8.11	42.38	31.49	31.69	-1.67	-0.82
PB8 WC-48	11.54		44.41		32.40	-1.71	
PB8 WC-49	11.81				33.40	-1.77	
PB8 WC-50	12.16	8.19	42.94	33.90	36.44	-1.79	-6.65
PB8 WC-51	12.35	8.15	42.73	30.22	31.20	-1.60	-0.80
PB8 WC-52	12.63	8.12	41.45	30.47	31.44	-1.62	-2.01
PB8 WC-53	13.12		44.10	32.64	33.86	-1.73	-0.72
PB8 WC-54	13.38	8.10	43.04	30.56	31.26	-1.62	-0.30
PB8 WC-55	13.59	8.38	41.71	31.50	31.97	-1.67	-0.35
PB8 WC-56	14.23	8.30	40.65	31.72	31.81	-1.68	-1.81
PB8 WC-57	14.55		41.33	31.07	31.20	-1.65	-1.18
PB8 WC-58	15.24	8.35	41.46	31.42	31.63	-1.66	-2.02
PB8 WC-59	15.33	8.39	40.21	31.15	31.01	-1.65	-1.47
PB8 WC-60	15.90		39.57		31.82	-1.68	
PB8 WC-61	16.13				32.94	-1.74	
PB8 WC-62	16.68				35.65	-1.88	
PB8 WC-63	16.99		39.72		33.21	-1.76	

Table 2 continued.

1 SAMPLE	2 DEPTH		3 Con- duct- ivity	Salinity	4 Salinity (after UNESCO, 1966)	5 Calcu- lated Freezing Point	6 Ionic Balance
PB8 WC-64	17.61		39.88		32.66	-1.73	
PB8 WC-65	18.40				36.57	-1.93	
PB8 WC-66	18.86		42.51		32.74	-1.73	
PB8 WC-67	19.30	8.01	40.21	32.80	32.76	-1.74	-0.56
PB8 WC-68	20.44	7.85	43.22	33.56	33.62	-1.77	-0.15
PB8 WC-69	26.55	7.99	45.17		34.74	-1.83	
PH25 WC-2	2.30	7.85	52.34	39.35	37.77	-2.07	1.12
PH25 WC-5	2.68	7.82	55.22	41.02	39.96	-2.16	0.38
PH27 WC-1	1.95	7.66	63.06	49.77	49.04	-2.61	0.66
PH27 WC-3	2.17	7.73	62.59	47.77	47.73	-2.50	1.35
PH27 WC-5	2.37	7.81	72.89	55.71	57.56	-2.91	2.20
PB9 WC-1A	0.15	7.75	1.71	0.94	0.80	-0.10	3.42
PB9 WC-1B	0.15	8.19	1.66	0.94	0.75	-0.10	1.92
PB9 WC-2A	0.46	7.70	1.37	0.88	0.53	-0.10	1.26
PB9 WC-2B	0.46	7.94	0.58	0.56	0.09	-0.08	-19.65
PB9 WC-2C	0.46	7.66	0.45	0.46	0.04	-0.07	-19.21
PB9 WC-3A	0.76	7.49	0.55	0.47	0.09	-0.07	-14.53
PB9 WC-3B	0.76	7.30	1.19	0.77	0.36	-0.09	-5.73
PB9 WC-4A	1.07	7.69	2.48	1.41	1.13	-0.12	-1.43
PB9 WC-4B	1.07	7.53	1.51	0.93	0.58	-0.10	-6.11
PB9 WC-4C	1.07	8.05	1.10	0.79	0.35	-0.09	-3.84
PB9 WC-5A	1.37	7.87	2.02	1.26	0.81	-0.11	1.20
PB9 WC-5B	1.37	7.74	2.29	1.38	0.94	-0.12	0.69
PB9 WC-6A	3.12	8.31	1.61	1.09	0.62	-0.11	-3.62
PB9 WC-6B	3.12	8.38	1.49	0.92	0.57	-0.10	-2.48
PB9 WC-7	3.73	8.19	2.86	1.74	1.24	-0.14	-1.31
PB9 WC-8A	5.03	8.30	7.10	4.19	3.05	-0.27	6.43
PB9 WC-8B	5.03	8.31	6.60	4.00	2.91	-0.26	4.05
PB9 WC-9A	6.78				5.03	-0.31	
PB9 WC-9B	6.78	8.33	10.44	5.46	5.02	-0.33	12.82
PB9 WC-11	11.05	8.20	16.93	10.14	10.36	-0.57	3.03
PB9 WC-12	13.26	8.31	12.71	7.37	7.41	-0.43	4.31
PB9 WC-13	14.10	8.21	19.52	12.11	12.43	-0.67	6.73
PB9 WC-14	16.31	7.84	18.07	10.81	11.12	-0.61	4.00
PB9 WC-15	17.14		17.84		12.58	-0.70	
SW1 WS-1	1.83				33.94	-1.79	
SW1 WS-2	3.05				33.51	-1.77	
SW1 WS-3	4.27				33.69	-1.78	
SW2 WS-1	1.83				33.82	-1.79	
SW2 WS-2	3.66				33.69	-1.78	
SW2 WS-3	5.18				33.69	-1.78	
PB7 WS-1	0.30				34.54	-1.82	
PB7 WS-2	3.05				34.24	-1.81	
PB5 WS-1	1.62	7.88	55.74	39.99	39.78	-2.10	1.05
PB6 WS-1	1.83	7.62	75.10	57.27	58.36	-2.99	-0.99
PB7 WS-3	1.95	7.91	50.81	35.32	35.34	-1.86	1.07
PB8 WS-1	2.00	7.88	47.67	33.54	33.77	-1.77	1.51
PB8 WS-2	4.50	7.86	47.05	33.46	33.54	-1.77	1.30
PB8 WS-3	7.00	7.97	44.21	33.38	33.67	-1.77	1.05

1
"PB" is borehole number, "PH" is probe hole number, "SW" is seawater collection site number, "WC" is sediment sample number, and "WS" is seawater sample number.

2
in meters below sea ice surface

3
in millimhos per centimeter, corrected to 25°C

4
sum of cations and anions, in parts per thousand

5
in degrees Celsius

6
in percent of total ionic strength, see text.

equation:

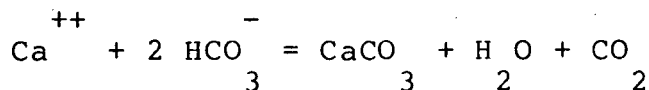

Only one-half of the bicarbonate ion concentration contributes to the total dissolved solids (or salinity); the other half is lost as carbon dioxide and water. The second method is to multiply the chloride ion concentration (or chlorinity) by 1.80655 (UNESCO, 1966). The calculated salinities are presented in Table 2.

The results show that the two correlate very well. The chloride salinities tend to be slightly higher (mean difference is 0.48 ppt) than those obtained by summing the cations and the anions. This difference is not surprising because the chemical analyses presented here do not include bromine, strontium, boron, silica, or other constituents which contribute to the salinity. Also, seawater is commonly oversaturated with respect to calcium carbonate, whereas sediments tend to be just at saturation (Siever et al., 1965). Therefore, the chloride ion to salinity ratio should be higher in sediments than in seawater. The data in this study suggest that this relationship is true, although the results were not significant when compared to analytical precision.

The salinities for seawater are interesting in two respects. First, the under-ice salinity in early spring is higher near the shore than in deeper water. This trend is also found in the conductivity data. At PB6, where salt exclusion from sea ice results in the formation of concentrated brines underneath the ice, the conductivity was 75 mmhos/cm. Further offshore, the conductivity was lower, being 51 mmhos/cm at PB7. Similar findings have been reported by Iskandar et al. (1978), Osterkamp and Harrison (1976), Lewellen (1973 and 1974), and Schell (1973). In general, the highest salinities and conductivities have been recorded inside of the 2-m isobath where sea ice is frozen directly to, or is located near, the sea bottom, or where circulation in the water column beneath the ice is restricted, as in PB1 (Fig. 3). Where ice is not located near the sea bottom or when circulation with deeper water is maintained, the salinity and conductivity of the water are much lower.

Secondly, the data reported for PB8 suggest that, in early spring, the under-ice salinities in the coastal waters of the Beaufort Sea are lower than the salinity for normal seawater. This has been found by other investigators as well including Lewellen (1973 and 1974) and Schell (1973), who reported open water, under-ice salinities of 33.2 to 33.7 and 30.4 to 33.9 ppt, respectively. All of these

measurements agree with O'Rourke's (1974) work on the water masses in the Arctic Ocean. He found that the "Arctic Ocean water" was generally less saline than normal seawater and attributed this to mixing of surface runoff with deeper "Atlantic water" off the Siberian coast.

In the sediments, both the salinity and conductivity are more variable. At PB5 and PB6, for example, the salinity and conductivity of the interstitial water from sediments located near the surface of the sea bed are higher than those occurring in the sediments deeper in the hole. These higher salinities and conductivities suggest that concentrated brines are infiltrating into the sediments from the seawater above. Data from Osterkamp and Harrison's (1976) study support this hypothesis. Immediately beneath these sediments, the conductivity and salinity drop, in some cases, to a point much lower than those salinities (or conductivities) found in the rest of the sediment column. For example, at PB6, the salinity dropped from 47.5 ppt (66.2 mmhos/cm) at the surface of the sediments to 31.9 ppt (45.8 mmhos/cm) at a depth of 25 cm below the sediment/water interface. Below this depth, the salinity gradually rose to 45.6 ppt (62.2 mmhos/cm) at a depth of about 1 m from the surface of the sea bed. This freshening may be the result of freezing in these sediments. If this hypothesis is true, then the high salinities (56 ppt) and conductivities (77.1 mmhos/cm) encountered in the sediments at a depth of about 2.5 to 5 m below the sediment/water interface could have resulted from brine exclusion. Similar freshenings are found at the bottom of PB6 and at the surface of PB7.

On land, both the salinity and conductivity of the pore water are much lower, as would be expected (Table 2). The lowest salinities and conductivities are found at a depth of 0.5 to 0.8 m, the same depth with the maximal water content and the maximal organic carbon content (cf. O'Sullivan, 1963 and Brown, 1969). Below a depth of about 4 m, the salinity and conductivity gradually rise to a maximum at a depth of 14 m. Similar trends of increasing conductivity and salinity with increasing depth have been reported by Brown (1969), by O'Sullivan (1963), and by Osterkamp and Harrison (1976).

Temperature and Calculated Freezing Points

To pursue the hypothesis that the marine sediments near the surface of the sea bed may be frozen, and to help confirm the position of ice-bonded permafrost with depth, freezing points were calculated from the salinity data. In most cases, the salinities based on the chemical analyses were used. Only when the chemical analysis for a sample was incomplete was the salinity based on the chloride ion concentration used. The freezing points were calculated using the following formula:

$$\text{Freezing Point} = -0.00249 - 0.0533 \times S - 0.0000764 \times S^2$$

$$+ 0.00000187 \times S^3 - 0.000763 \times Z$$

$$\text{Correlation Coefficient} = 0.999993$$

where S is the salinity in parts per thousand (ppt) and Z is the depth of a sample in meters. The first four terms of this formula were obtained by a least squares analysis of the salinity versus freezing point data for seawater as listed in the 57th edition of the Handbook of Chemistry and Physics (1976). The last term is taken from Fujino et al. (1974) and is used to correct for changes in the freezing point due to hydrostatic pressure. The calculated results are listed in Table 2.

Preliminary temperature data were obtained from B.V. Marshall and Dr. A.H. Lachenbruch of the U.S. Geological Survey (personal communication, 1977). These measurements were taken several weeks after the completion of drilling. Because the thermal disturbance due to drilling operations was probably minimal (Sellmann, personal communication, 1977), it can probably be safely assumed that the temperature profiles presented here are close to the in situ thermal conditions that were existent prior to drilling.

For the seawater samples, the calculated freezing points should be equal to the in situ water temperature. This assumes that all of the seawater samples were in equilibrium with the sea ice. If this assumption is valid, then the seawater temperatures at PB5, PB6, PB7, and PB8 were -2.1°C, -2.95°C, -1.9°C, and -1.8°C, respectively. These values generally agree with data reported by Chamberlain et al. (1978) and by Osterkamp and Harrison (1976). For example, Osterkamp and Harrison found a temperature of -1.8°C at hole 3370, the same site as PB7 (-1.87°C). Chamberlain et al. have reported a temperature of approximately -1.7°C for the sediments located near the surface of the sea bed at PB2 and PB3. This temperature is close to the temperatures found at PB8, SW1, and SW2 (Table 2). These temperatures, and other temperature data reported by Chamberlain et al. and Osterkamp and Harrison, indicate that the temperature of the seawater is colder nearer the shore, where sea ice lies on or near the sea bed, than in deeper water.

In sediments, the relationship between the calculated freezing point and the in situ temperature is more complicated because of the effects of surface tension on the freezing point. Fine-grained materials, such as silts and clays, have relatively high surface tensions. These tensions essentially increase the pressure on the water in the pore water system, resulting in lower freezing points.

Because it is very difficult (if possible) to estimate the effects of surface tension on the freezing point of the interstitial water, freezing points calculated on the basis of salinity and hydrostatic pressure should be used with some caution.

Figures 11-14 show the calculated freezing points of the interstitial water samples plotted alongside the temperature data. In PB6 (Fig. 12), the sediment sample (PB6 WC-15) which had the lowest salinity and conductivity (Table 2) is probably frozen to some degree. If the temperature profile is extrapolated to intersect the seawater temperature of -2.95°C (dashed line), then it appears that most of the sediments in the upper 2 to 2.5 m of the sediment column are also frozen and that brine exclusion is responsible for the higher salinities in the sediments immediately below this freezing layer (PB6 WC-21 and PB6 WC-22, Table 2). The sediments at the bottom of PB6 also appear to be frozen. Driller's notes on the preliminary logs mention difficulty in drilling at a depth of 30.5 m, the same depth at which the ground temperature is lower than the freezing point. This is the position at which ice-bonded permafrost was probably first encountered.

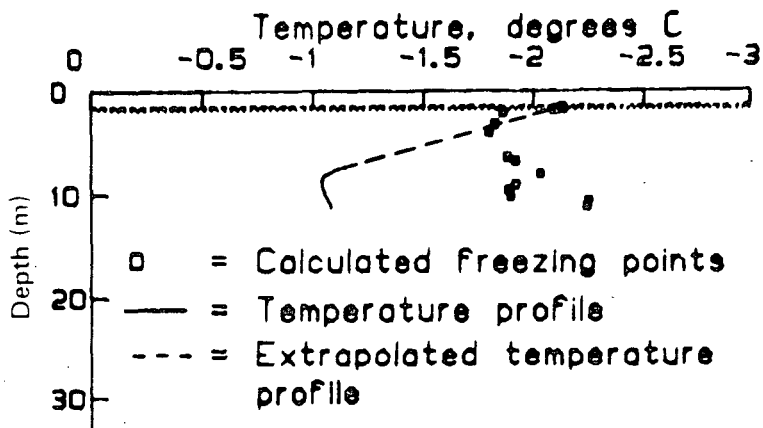

Figure 11. Temperature and calculated freezing points as a function of depth for borehole PB5 (Temperature data courtesy of B.V. Marshall and Dr. A.H. Lachenbruch, U.S.G.S.).

In PB5 (Fig. 11), the salinities are slightly lower in the sediments down to a depth of about 2 m below the surface of the sea bed than in the sediments deeper in the hole (Table 2). If the temperature curve is extrapolated to intersect the calculated freezing point of the seawater samples (Fig. 11), then the sediments in the upper 2 m of the sediment column may also have been partially frozen. The slightly higher salinities at a depth of 5 m below the surface of the sea bed may have resulted from brine exclusion.

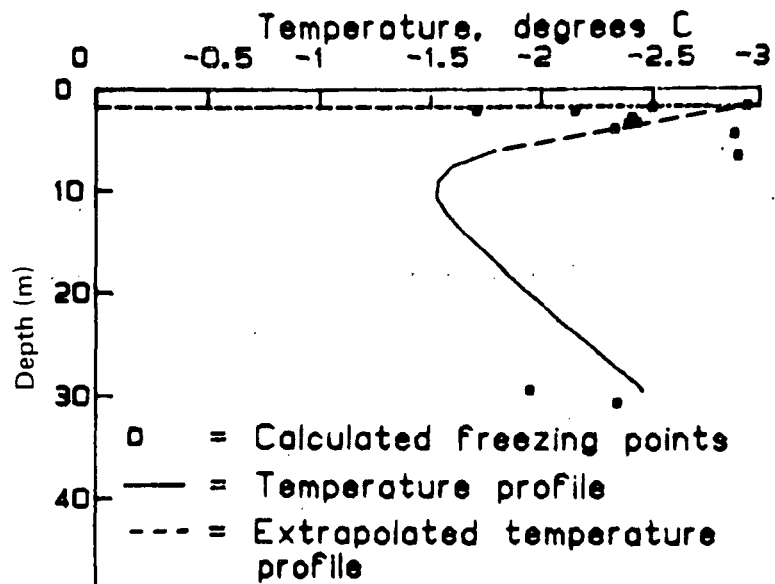

Figure 12. Temperature and calculated freezing points as a function of depth for borehole PB6 (Temperature data courtesy of B.V. Marshall and Dr. A.H. Lachenbruch, U.S.G.S.).

In PB7 (Fig. 13), the sediments at the surface of the sea bed again appear to be at least partially frozen. The rest of the sediments in the profile appear to be thawed with the exception of the two samples (PB7 WC-37 and PB7 WC-38) located near the bottom of the hole. The calculated freezing points for these samples indicate that the sediments may have been frozen. Chamberlain (personal communication, 1977) has indicated that increased resistance to drilling did occur at these depths although no visible ice was found.

Figure 14 shows the calculated freezing point and temperature profiles for PB8. The temperature data and the calculated freezing points for the seawater samples were not equal as they should be. This discrepancy may have resulted from convection in the fluid inside the casing in which the temperature measurements were made. The upper 3 to 3.5 m of sediment appear to be at least partially frozen. Immediately below this layer, higher salinities are encountered (PB8 WC-48, PB8 WC-49, and PB8 WC-50), which once again can be attributed to brine exclusion.

Ionic Balance

Table 3 presents the results of the major cation and anion analyses. As would be expected, sodium and chloride are the major cation and anion, respectively. Most of the ions range from very low concentrations in the ice-rich peats of PB9 to very high values at PB6. To check the

quality of the data, ionic balances were computed. The ionic balance compares the difference between the cations and the anions, in milliequivalents per liter (meq/l), to the total number of ions in the solution. The formula used is given below.

$$\text{Ionic Balance (\%)} = \frac{(\text{sum of cations}) - (\text{sum of anions})}{(\text{sum of cations}) + (\text{sum of anions})} \times 100$$

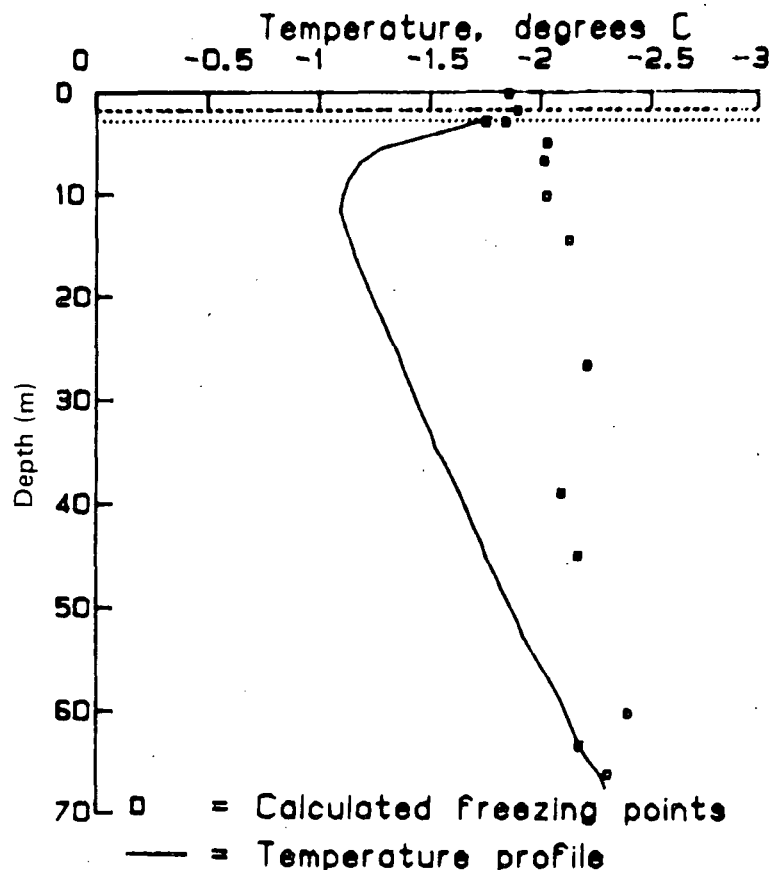

Figure 13. Temperature and calculated freezing points as a function of depth for borehole PB7 (Temperature data courtesy of B.V. Marshall and Dr. A.H. Lachenbruch, U.S.G.S.).

The results are presented in Tables 2 and 4. These calculations show that the net differences between the sum of the cations and the anions are generally within 3 to 4 %. The highest values were obtained from PB9 and were the result of low total salt content rather than large differences between the cations and the anions. For example, the three samples (PB9 WC-2B, PB9 WC-2C, and PB9 WC-3A) which have the highest ionic balances (14.53 to 19.65 %) had total differences between the cations and the anions

of only 1.9 to 2.7 meq/l (see the Appendix). This is well below the mean for the rest of the samples.

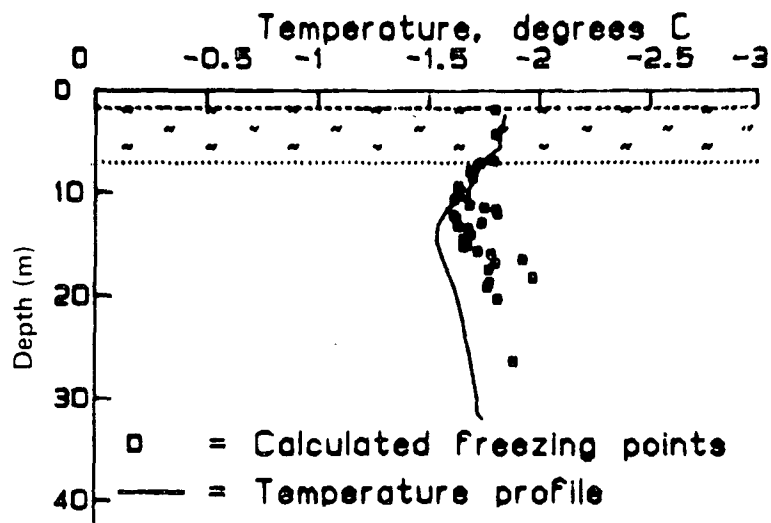

Figure 14. Temperature and calculated freezing points as a function of depth for borehole PB8 (Temperature data courtesy of B.V. Marshall and Dr. A.H. Lachenbruch, U.S.G.S.).

Ionic Ratios

Sodium to Chloride Ratio

The chemical data have also been checked by comparing the sodium to chloride ratio for the interstitial water to that for normal seawater. Because this is a marine environment, these two ratios should be similar. Figure 15 is a plot of the sodium concentration versus the chloride concentration, using all the data, including those obtained for PB9. With the exception of the two spurious points, a linear regression analysis showed that the slope of the line was 0.560. This slope agrees well with the value of 0.556 for normal seawater.

Other Ionic Ratios

Table 5 presents a number of ionic ratios for the seawater and interstitial water samples. These ratios provide more information about possible diagenetic and/or chemical changes than the chemical analyses listed in Table 3 because they eliminate variations due strictly to changes in salinity.

Table 6 presents a summary of the ionic ratios for the seawater samples. With the exception of sodium and possibly magnesium, the cation to chloride ratios are higher, and the anion to chloride ratios are lower, than the corresponding

Table 3. Chemical analyses of interstitial and seawater samples from Prudhoe Bay, Alaska; in parts per thousand.

1	2	+	+	++	++	-	=	- 3
SAMPLE	DEPTH	Na	K	Ca	Mg	Cl	SO4	HCO3
PB5 WC-1	1.80	12.59	0.62	0.51	1.53	22.96	1.64	0.21
PB5 WC-2	1.94	12.44	0.61	0.55	1.47	21.93	2.10	0.19
PB5 WC-3	2.16	10.68	0.59	0.50	1.23	19.35	2.14	0.23
PB5 WC-4	3.34	10.66	0.59	0.44	1.16	19.52	1.40	0.21
PB5 WC-5	6.50	11.03	0.62	0.47	1.23	19.85	1.56	0.21
PB5 WC-6	6.90	11.11	0.62	0.44	1.21	19.98	2.24	0.25
PB5 WC-7	4.10	10.10	0.59	0.42	1.08	19.52	1.51	0.24
PB5 WC-8	8.11	11.95	0.66	0.44	1.26	21.04	2.40	0.23
PB5 WC-9	9.20	11.12	0.57	0.48	1.33	20.58	1.49	0.25
PB5 WC-10	9.70	11.04	0.58	0.44	1.30	19.83	1.60	0.24
PB5 WC-11	10.35	11.06	0.61	0.43	1.29	20.25	1.49	0.20
PB5 WC-12	10.85	13.29	0.78	0.63	1.46	23.82	2.00	0.15
PB5 WC-13	11.33	13.49	0.76	0.60	1.46	23.69	1.88	0.17
PB6 WC-14	1.90	14.88	0.75	0.68	1.72	26.70	2.60	0.18
PB6 WC-15	2.15	10.81	0.48	0.46	1.15	17.16	1.57	0.25
PB6 WC-16	2.30	12.45	0.56	0.57	1.58	22.47	2.58	0.23
PB6 WC-17	2.93	14.08	0.79	0.64	1.69	25.56	2.63	0.24
PB6 WC-18	3.40	14.78	0.88	0.67	1.69	24.81	2.99	0.22
PB6 WC-19	3.63	14.30	0.90	0.66	1.62	24.84	2.64	0.21
PB6 WC-20	4.10	13.56	0.71	0.69	1.67	24.93	2.25	0.22
PB6 WC-21	4.56	17.84	1.18	0.86	2.00	31.31	2.45	0.24
PB6 WC-22	6.79	17.61	0.90	0.85	2.17	32.43	1.97	0.20
PB6 WC-23	29.72	11.08	0.59	0.59	1.25	20.54	1.78	0.10
PB6 WC-24	30.87	13.76	0.61	0.85	1.60	25.46	1.34	0.08
PB7 WC-25	2.91	10.01	0.54	0.46	1.13	18.12	2.13	0.23
PB7 WC-26	3.03	10.07	0.54	0.37	1.17	18.32	1.87	0.33
PB7 WC-27	5.15	11.65	0.63	0.52	1.34	20.97	2.48	0.39
PB7 WC-28	6.92	11.72	0.81	0.55	1.26	21.27	1.82	0.27
PB7 WC-29	10.25	11.73	0.62	0.61	1.35	21.50	1.82	0.31
PB7 WC-31	14.56	12.14	0.66	0.66	1.44	22.46	2.16	0.23
PB7 WC-33	26.70	12.45	0.71	0.69	1.49	23.15	2.51	0.21
PB7 WC-34	38.98	11.99	0.62	0.58	1.40	21.50	2.52	0.17
PB7 WC-35	45.07	12.46	0.72	0.65	1.44	22.66	2.16	0.20
PB7 WC-36	60.45	13.94	0.81	0.60	1.52	24.94	2.58	0.12
PB7 WC-37	63.60	12.32	0.64	0.59	1.45	22.42	2.47	0.14
PB7 WC-38	66.56	13.47	0.76	0.55	1.36	24.12	2.26	0.17
PB8 WC-39	7.22	10.05	0.59	0.41	1.10	17.83	2.05	0.27
PB8 WC-40	7.97	10.05	0.60	0.30	1.00	17.59	1.44	0.61
PB8 WC-41	8.62	10.09	0.55	0.26	0.95	17.83	1.40	0.68
PB8 WC-42	9.47	9.99	0.62	0.21	0.82	17.43	0.74	0.70
PB8 WC-43	10.08	10.04	0.54	0.16	0.81	17.33	1.15	0.79
PB8 WC-44	10.27	9.77	0.51	0.22	0.86	17.49	1.00	0.74
PB8 WC-45	10.48	9.95	0.51	0.15	0.85	17.40	1.41	1.13
PB8 WC-46	10.82	9.86	0.58	0.15	0.74	17.25	0.86	0.72
PB8 WC-47	11.37	10.13	0.57	0.16	0.81	17.54	1.56	0.72
PB8 WC-48	11.54	10.25	0.61	0.14	0.77	17.94	1.09	
PB8 WC-49	11.81	10.45	0.63	0.14	0.76	18.49	1.07	
PB8 WC-50	12.16	10.32	0.58	0.11	0.75	20.17	1.23	0.75
PB8 WC-51	12.35	9.77	0.58	0.12	0.79	17.27	0.90	0.80
PB8 WC-52	12.63	9.70	0.55	0.11	0.79	17.40	1.08	0.84
PB8 WC-53	13.12	10.66	0.60	0.12	0.82	18.74	0.78	0.92
PB8 WC-54	13.38	9.94	0.51	0.12	0.83	17.31	0.92	0.93
PB8 WC-55	13.59	10.17	0.58	0.12	0.86	17.70	1.08	0.98
PB8 WC-56	14.23	10.01	0.54	0.14	0.85	17.61	1.52	1.06
PB8 WC-57	14.55	9.89	0.53	0.14	0.84	17.27	1.37	1.02
PB8 WC-58	15.24	9.86	0.53	0.13	0.87	17.51	1.48	1.05
PB8 WC-59	15.33	9.80	0.51	0.13	0.88	17.16	1.51	1.15
PB6 WC-60	15.90	10.20	0.53	0.14	0.90	17.61	1.83	

Table 3 continued.

1 SAMPLE	2 DEPTH	+	+	++	++	-	=	- 3
		Na	K	Ca	Mg	Cl	SO4	HCO3
PB8 WC-61	16.13	10.43	0.52	0.15	0.94	18.23	2.14	
PB8 WC-62	16.68	16.03	0.87	0.25	1.44	19.74	1.93	
PB8 WC-63	16.99	10.88	0.58	0.27	1.12	18.38	2.44	
PB8 WC-64	17.61	10.20	0.55	0.20	1.02	18.08	1.76	
PB8 WC-65	18.40	16.52	0.89	0.32	1.59	20.24	2.05	
PB8 WC-66	18.86	10.31	0.53	0.23	1.06	18.12	2.10	
PB8 WC-67	19.30	10.25	0.53	0.23	1.05	18.13	2.13	0.47
PB8 WC-68	20.44	10.23	0.54	0.35	1.21	18.61	2.28	0.33
PB8 WC-69	26.55	11.02	0.63	0.58	1.22	19.23	2.34	
PH25 WC-2	2.30	12.14	0.64	0.52	1.36	20.91	3.51	0.27
PH25 WC-5	2.68	12.58	0.67	0.51	1.41	22.12	3.43	0.31
PH27 WC-1	1.95	15.31	0.76	0.66	1.75	27.15	3.91	0.23
PH27 WC-3	2.17	14.77	0.67	0.63	1.80	26.42	3.18	0.31
PH27 WC-5	2.37	17.35	0.92	0.78	2.17	31.86	2.34	0.30
PB9 WC-1A	0.15	0.20	0.01	0.11	0.02	0.44	0.04	0.11
PB9 WC-1B	0.15	0.16	0.01	0.13	0.02	0.41	0.08	0.12
PB9 WC-2A	0.46	0.15	0.01	0.11	0.02	0.29	0.10	0.19
PB9 WC-2B	0.46	0.04	0.01	0.06	0.01	0.05	0.19	0.20
PB9 WC-2C	0.46	0.02	0.00	0.06	0.01	0.02	0.16	0.17
PB9 WC-3A	0.76	0.02	0.00	0.08	0.01	0.05	0.14	0.18
PB9 WC-3B	0.76	0.04	0.01	0.15	0.02	0.02	0.14	0.21
PB9 WC-4A	1.07	0.15	0.01	0.26	0.03	0.62	0.12	0.21
PB9 WC-4B	1.07	0.07	0.01	0.17	0.02	0.32	0.14	0.21
PB9 WC-4C	1.07	0.11	0.01	0.10	0.02	0.19	0.16	0.21
PB9 WC-5A	1.37	0.16	0.01	0.21	0.03	0.45	0.11	0.29
PB9 WC-5B	1.37	0.16	0.01	0.24	0.04	0.52	0.14	0.27
PB9 WC-6A	3.12	0.19	0.02	0.07	0.05	0.34	0.20	0.23
PB9 WC-6B	3.12	0.18	0.02	0.05	0.04	0.31	0.16	0.16
PB9 WC-7	3.73	0.37	0.03	0.09	0.08	0.69	0.26	0.23
PB9 WC-8A	5.03	0.85	0.13	0.32	0.24	1.69	0.71	0.25
PB9 WC-8B	5.03	0.79	0.12	0.29	0.21	1.61	0.71	0.26
PB9 WC-9A	6.78	1.45	0.21	0.33	0.23	2.79		
PB9 WC-9B	6.78	1.45	0.14	0.38	0.31	2.78	0.25	0.15
PB9 WC-11	11.05	3.10	0.23	0.27	0.32	5.73	0.25	0.21
PB9 WC-12	13.26	2.18	0.25	0.24	0.24	4.10	0.18	0.17
PB9 WC-13	14.10	3.75	0.26	0.49	0.42	6.88	0.13	0.19
PB9 WC-14	16.31	3.34	0.31	0.36	0.29	6.15	0.21	0.14
PB9 WC-15	17.14	3.79	0.31	0.31	0.24	6.96		0.18
SW1 WS-1	1.83	10.47	0.44	0.42	1.25	18.78	1.92	
SW1 WS-2	3.05	10.48	0.44	0.41	1.27	18.55	2.12	
SW1 WS-3	4.27	10.35	0.43	0.41	1.25	18.65	2.41	
SW2 WS-1	1.83	10.54	0.45	0.41	1.27	18.72	2.03	
SW2 WS-2	3.66	10.48	0.45	0.42	1.26	18.65	2.81	
SW2 WS-3	5.18	10.65	0.42	0.42	1.26	18.65	2.41	
PB7 WS-1	0.30	10.89	0.45	0.44	1.30	19.12	2.37	
PB7 WS-2	3.05	10.75	0.45	0.42	1.29	18.95	2.57	
PB5 WS-1	1.62	12.36	0.53	0.49	1.50	22.02	2.94	0.14
PB6 WS-1	1.83	17.18	0.76	0.71	2.13	32.31	3.97	0.21
PB7 WS-3	1.95	10.93	0.46	0.44	1.32	19.56	2.47	0.12
PB8 WS-1	2.00	10.44	0.45	0.42	1.28	18.69	2.15	0.11
PB8 WS-2	4.50	10.40	0.45	0.42	1.25	18.57	2.25	0.12
PB8 WS-3	7.00	10.34	0.44	0.42	1.25	18.64	2.16	0.13

1 "PB" is borehole number, "PH" is probe hole number, "SW" is seawater collection site number, "WC" is sediment sample number, and "WS" is seawater sample number

2 in meters

3 alkalinity is expressed as bicarbonate

Table 4. Summary of the ionic balances in all interstitial and seawater samples.

	Mean	99 %	Maximum	Mean	99 %	Maximum
		Confidence Interval			Confidence Interval	
	% -----			Milliequivalents per liter -----		
All Samples	2.58	± 0.97	19.65	17.11	± 4.84	79.98
Seawater	1.16	± 0.33	1.51	15.33	± 4.63	19.59
Marine Sediments	1.58	± 0.45	7.13	21.39	± 6.33	79.98
Land Sediments	5.81	± 3.39	19.65	5.54	± 4.89	28.7

ratios for normal seawater. The enrichments in potassium and calcium are also reflected in the lower sodium to potassium and the higher calcium to magnesium ratios. Generally, there is no explanation for these variations from the composition of normal seawater. The potassium and calcium enrichments may possibly be due to low biological activity, which would normally remove these ions from the water in the formation of cellular protoplasm and calcareous shells.

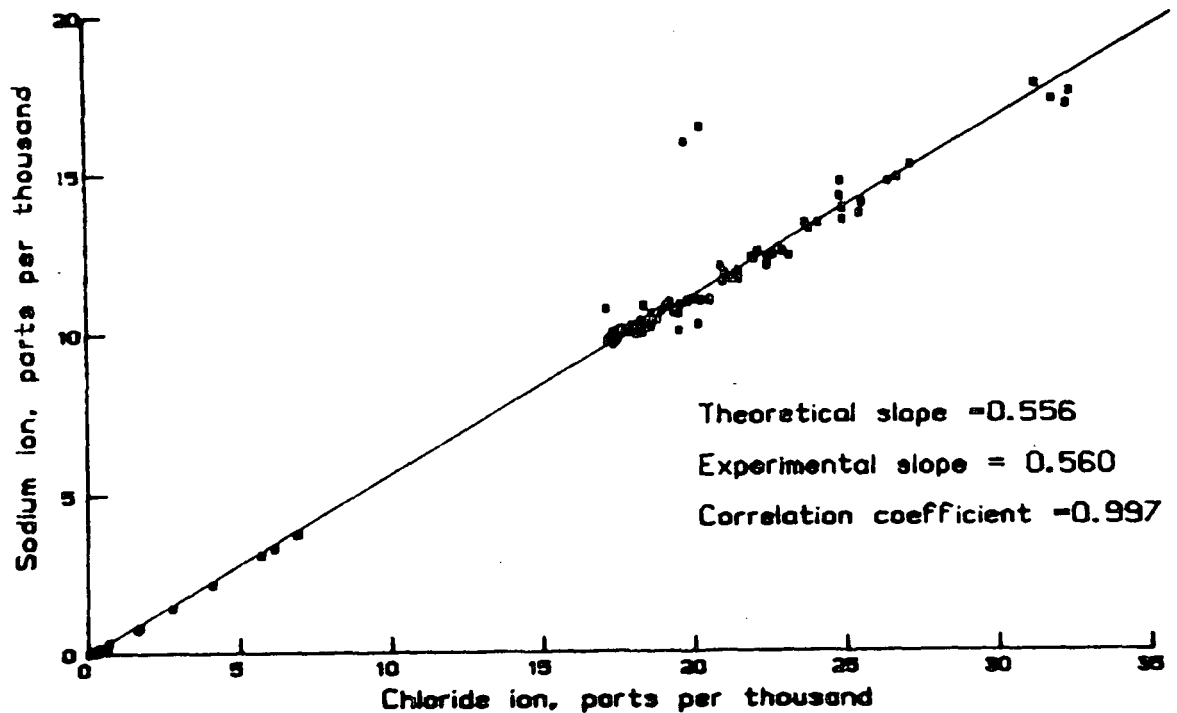

Figure 15. Sodium ion concentration as a function of chloride ion concentration.

Table 7 presents a summary of the mean ionic ratios for the pore water from each of the boreholes. In the marine sediments, only two samples (PB6 WC-62 and PB6 WC-65, Table 5) have sodium to chloride ratios which are significantly different from that for normal seawater. The chemical analyses for these samples (Table 3) indicate that the sodium, potassium, and magnesium concentrations are all substantially higher than those from samples immediately adjacent to them. Cation-anion balances would also require that the bicarbonate ion concentration be between 250 and 275 meq/l (15.3 to 16.8 ppt), a concentration much higher than the highest measured concentration of 18.8 meq/l (1.15 ppt) (see the Appendix). These discrepancies may be due to the extremely small water volumes that were extracted by centrifugation (0.65 and 0.56 g total water from PB6 WC-62 and PB6 WC-65, respectively), to evaporation, or possibly to

Table 5. Selected ionic ratios for seawater and interstitial water, by weight.

SAMPLE	1	2							
	DEPTH	Na:Cl	K:Cl	Ca:Cl	Mg:Cl	SO4:Cl	HCO3:Cl	Na:K	Ca:Mg
PB5 WC-1	1.80	0.548	0.0269	0.0223	0.0664	0.072	0.0093	20.35	0.335
PB5 WC-2	1.94	0.567	0.0276	0.0248	0.0669	0.096	0.0086	20.54	0.371
PB5 WC-3	2.16	0.552	0.0303	0.0260	0.0635	0.110	0.0118	18.20	0.409
PB5 WC-4	3.34	0.546	0.0304	0.0226	0.0596	0.072	0.0106	17.98	0.379
PB5 WC-5	6.50	0.556	0.0315	0.0234	0.0621	0.079	0.0105	17.65	0.378
PB5 WC-6	6.90	0.556	0.0309	0.0222	0.0606	0.112	0.0127	17.98	0.366
PB5 WC-7	4.10	0.517	0.0300	0.0217	0.0555	0.077	0.0123	17.26	0.391
PB5 WC-8	8.11	0.568	0.0312	0.0208	0.0597	0.114	0.0110	18.21	0.348
PB5 WC-9	9.20	0.540	0.0277	0.0233	0.0645	0.073	0.0120	19.48	0.361
PB5 WC-10	9.70	0.557	0.0291	0.0224	0.0658	0.081	0.0122	19.13	0.340
PB5 WC-11	10.35	0.546	0.0302	0.0211	0.0637	0.074	0.0097	18.07	0.332
PB5 WC-12	10.85	0.558	0.0329	0.0266	0.0614	0.084	0.0063	16.96	0.433
PB5 WC-13	11.33	0.569	0.0321	0.0252	0.0617	0.080	0.0071	17.76	0.409
PB6 WC-14	1.90	0.557	0.0282	0.0256	0.0643	0.097	0.0067	19.77	0.398
PB6 WC-15	2.15	0.630	0.0282	0.0271	0.0671	0.091	0.0148	22.36	0.404
PB6 WC-16	2.30	0.554	0.0250	0.0255	0.0701	0.115	0.0102	22.11	0.363
PB6 WC-17	2.93	0.551	0.0308	0.0249	0.0659	0.103	0.0092	17.87	0.377
PB6 WC-18	3.40	0.596	0.0356	0.0271	0.0680	0.120	0.0090	16.72	0.398
PB6 WC-19	3.63	0.576	0.0360	0.0268	0.0652	0.106	0.0086	15.98	0.411
PB6 WC-20	4.10	0.544	0.0284	0.0275	0.0672	0.090	0.0089	19.14	0.410
PB6 WC-21	4.56	0.570	0.0377	0.0276	0.0637	0.078	0.0075	15.10	0.433
PB6 WC-22	6.79	0.543	0.0277	0.0263	0.0668	0.061	0.0061	19.57	0.394
PB6 WC-23	29.72	0.539	0.0289	0.0288	0.0610	0.087	0.0050	18.65	0.473
PB6 WC-24	30.87	0.540	0.0241	0.0333	0.0627	0.053	0.0033	22.38	0.531
PB7 WC-25	2.91	0.553	0.0298	0.0254	0.0626	0.117	0.0127	18.54	0.406
PB7 WC-26	3.03	0.549	0.0293	0.0204	0.0640	0.102	0.0181	18.77	0.318
PB7 WC-27	5.15	0.556	0.0299	0.0247	0.0638	0.118	0.0186	18.57	0.388
PB7 WC-28	6.92	0.551	0.0381	0.0260	0.0591	0.085	0.0128	14.48	0.440
PB7 WC-29	10.25	0.545	0.0289	0.0282	0.0627	0.085	0.0142	18.86	0.449
PB7 WC-31	14.56	0.540	0.0293	0.0296	0.0641	0.096	0.0102	18.44	0.461
PB7 WC-33	26.70	0.538	0.0305	0.0299	0.0643	0.108	0.0092	17.62	0.465
PB7 WC-34	38.98	0.558	0.0288	0.0269	0.0650	0.117	0.0081	19.35	0.414
PB7 WC-35	45.07	0.550	0.0317	0.0288	0.0634	0.096	0.0090	17.37	0.454
PB7 WC-36	60.45	0.559	0.0323	0.0239	0.0611	0.104	0.0049	17.29	0.392
PB7 WC-37	63.60	0.549	0.0285	0.0262	0.0647	0.110	0.0063	19.28	0.405
PB7 WC-38	66.56	0.559	0.0315	0.0227	0.0562	0.094	0.0071	17.73	0.403
PB8 WC-39	7.22	0.563	0.0330	0.0228	0.0618	0.115	0.0152	17.05	0.369
PB8 WC-40	7.97	0.571	0.0341	0.0172	0.0566	0.082	0.0345	16.75	0.304
PB8 WC-41	8.62	0.566	0.0309	0.0144	0.0531	0.078	0.0383	18.28	0.271
PB8 WC-42	9.47	0.573	0.0355	0.0119	0.0469	0.043	0.0400	16.13	0.253
PB8 WC-43	10.08	0.579	0.0310	0.0093	0.0469	0.066	0.0456	18.68	0.199
PB8 WC-44	10.27	0.559	0.0291	0.0123	0.0494	0.057	0.0421	19.23	0.249
PB8 WC-45	10.48	0.571	0.0296	0.0087	0.0488	0.081	0.0649	19.32	0.179
PB8 WC-46	10.82	0.572	0.0337	0.0084	0.0430	0.050	0.0417	16.96	0.196
PB8 WC-47	11.37	0.578	0.0325	0.0090	0.0464	0.089	0.0408	17.79	0.194
PB8 WC-48	11.54	0.572	0.0340	0.0080	0.0428	0.061		16.81	0.188
PB8 WC-49	11.81	0.565	0.0343	0.0076	0.0411	0.058		16.47	0.185
PB8 WC-50	12.16	0.512	0.0287	0.0054	0.0373	0.061	0.0370	17.81	0.144
PB8 WC-51	12.35	0.566	0.0334	0.0067	0.0458	0.052	0.0463	16.92	0.146
PB8 WC-52	12.63	0.557	0.0315	0.0061	0.0456	0.062	0.0486	17.71	0.134
PB8 WC-53	13.12	0.569	0.0321	0.0063	0.0436	0.042	0.0493	17.71	0.144
PB8 WC-54	13.38	0.574	0.0296	0.0069	0.0478	0.053	0.0536	19.40	0.145
PB8 WC-55	13.59	0.574	0.0329	0.0070	0.0487	0.061	0.0556	17.45	0.144
PB8 WC-56	14.23	0.568	0.0306	0.0080	0.0484	0.086	0.0602	18.59	0.166
PB8 WC-57	14.55	0.573	0.0306	0.0081	0.0487	0.080	0.0590	18.69	0.166
PB8 WC-58	15.24	0.563	0.0302	0.0072	0.0498	0.084	0.0598	18.67	0.144
PB8 WC-59	15.33	0.571	0.0299	0.0075	0.0516	0.088	0.0667	19.13	0.146
PB8 WC-60	15.90	0.579	0.0302	0.0078	0.0510	0.104		19.17	0.153
PB8 WC-61	16.13	0.572	0.0286	0.0081	0.0516	0.117		19.96	0.158

Table 5 continued.

SAMPLE	DEPTH ¹							²	
		Na:Cl	K:Cl	Ca:Cl	Mg:Cl	SO ₄ :Cl	HCO ₃ :Cl	Na:K	Ca:Mg
PB8 WC-62	16.68	0.812	0.0441	0.0128	0.0728	0.098		18.41	0.176
PB8 WC-63	16.99	0.592	0.0315	0.0149	0.0608	0.133		18.77	0.246
PB8 WC-64	17.61	0.564	0.0305	0.0112	0.0565	0.097		18.48	0.199
PB8 WC-65	18.40	0.816	0.0439	0.0157	0.0784	0.101		18.59	0.200
PB8 WC-66	18.86	0.569	0.0295	0.0126	0.0587	0.116		19.30	0.215
PB8 WC-67	19.30	0.565	0.0292	0.0129	0.0578	0.118	0.0260	19.35	0.224
PB8 WC-68	20.44	0.550	0.0291	0.0188	0.0651	0.123	0.0178	18.92	0.289
PB8 WC-69	26.55	0.573	0.0329	0.0303	0.0635	0.122		17.39	0.477
PH25 WC-2	2.30	0.581	0.0307	0.0248	0.0651	0.168	0.0127	18.90	0.381
PH25 WC-5	2.68	0.569	0.0305	0.0232	0.0636	0.155	0.0140	18.66	0.364
PH27 WC-1	1.95	0.564	0.0279	0.0243	0.0645	0.144	0.0084	20.24	0.377
PH27 WC-3	2.17	0.559	0.0254	0.0238	0.0680	0.120	0.0117	21.97	0.350
PH27 WC-5	2.37	0.544	0.0289	0.0243	0.0680	0.074	0.0093	18.86	0.358
PB9 WC-1A	0.15	0.444	0.0251	0.2553	0.0495	0.098	0.2483	17.69	5.155
PB9 WC-1B	0.15	0.397	0.0232	0.3252	0.0525	0.187	0.2957	17.08	6.189
PB9 WC-2A	0.46	0.505	0.0326	0.3852	0.0653	0.355	0.6479	15.47	5.902
PB9 WC-2B	0.46	0.797	0.1172	1.2591	0.1736	3.807	3.8717	6.80	7.253
PB9 WC-2C	0.46	0.873	0.1742	2.4794	0.2953	6.621	7.0128	5.01	8.396
PB9 WC-3A	0.76	0.407	0.0592	1.5355	0.1542	2.860	3.5205	6.88	9.958
PB9 WC-3B	0.76	0.215	0.0336	0.7352	0.0838	0.709	1.0586	6.39	8.777
PB9 WC-4A	1.07	0.243	0.0218	0.4188	0.0547	0.187	0.3343	11.14	7.655
PB9 WC-4B	1.07	0.213	0.0259	0.5404	0.0637	0.427	0.6413	8.23	8.488
PB9 WC-4C	1.07	0.551	0.0397	0.5343	0.0773	0.813	1.0692	13.88	6.910
PB9 WC-5A	1.37	0.348	0.0262	0.4637	0.0726	0.240	0.6494	13.26	6.385
PB9 WC-5B	1.37	0.308	0.0224	0.4620	0.0689	0.263	0.5139	13.73	6.705
PB9 WC-6A	3.12	0.552	0.0462	0.1921	0.1567	0.578	0.6711	11.95	1.226
PB9 WC-6B	3.12	0.562	0.0662	0.1519	0.1363	0.512	0.5113	8.49	1.115
PB9 WC-7	3.73	0.535	0.0392	0.1245	0.1216	0.375	0.3403	13.64	1.024
PB9 WC-8A	5.03	0.504	0.0749	0.1913	0.1399	0.421	0.1508	6.73	1.368
PB9 WC-8B	5.03	0.490	0.0768	0.1823	0.1335	0.440	0.1607	6.38	1.366
PB9 WC-9A	6.78	0.522	0.0750	0.1197	0.0824			6.96	1.453
PB9 WC-9B	6.78	0.522	0.0518	0.1364	0.1122	0.089	0.0543	10.08	1.216
PB9 WC-11	11.05	0.541	0.0408	0.0475	0.0564	0.044	0.0375	13.26	0.842
PB9 WC-12	13.26	0.532	0.0604	0.0591	0.0591	0.045	0.0411	8.80	1.000
PB9 WC-13	14.10	0.544	0.0377	0.0705	0.0617	0.019	0.0274	14.46	1.143
PB9 WC-14	16.31	0.543	0.0506	0.0580	0.0477	0.034	0.0229	10.74	1.217
PB9 WC-15	17.14	0.545	0.0444	0.0438	0.0352		0.0265	12.28	1.246
SW1 WS-1	1.83	0.557	0.0232	0.0222	0.0668	0.102		24.00	0.332
SW1 WS-2	3.05	0.565	0.0236	0.0223	0.0683	0.114		23.98	0.326
SW1 WS-3	4.27	0.555	0.0232	0.0218	0.0671	0.129		23.96	0.325
SW2 WS-1	1.83	0.563	0.0238	0.0221	0.0681	0.108		23.63	0.325
SW2 WS-2	3.66	0.562	0.0243	0.0224	0.0675	0.151		23.15	0.332
SW2 WS-3	5.18	0.571	0.0223	0.0223	0.0674	0.129		25.59	0.331
PB7 WS-1	0.30	0.570	0.0234	0.0230	0.0682	0.124		24.33	0.337
PB7 WS-2	3.05	0.567	0.0236	0.0222	0.0679	0.136		23.99	0.327
PB5 WS-1	1.62	0.562	0.0242	0.0224	0.0680	0.134	0.0064	23.21	0.329
PB6 WS-1	1.83	0.532	0.0235	0.0221	0.0660	0.123	0.0064	22.64	0.335
PB7 WS-3	1.95	0.559	0.0236	0.0227	0.0676	0.126	0.0063	23.65	0.336
PB8 WS-1	2.00	0.558	0.0238	0.0224	0.0684	0.115	0.0061	23.41	0.328
PB8 WS-2	4.50	0.560	0.0242	0.0227	0.0674	0.121	0.0067	23.15	0.337
PB8 WS-3	7.00	0.555	0.0238	0.0225	0.0672	0.116	0.0069	23.35	0.335

¹
in meters

²
alkalinity is expressed as bicarbonate ion.

Table 6. Summary of the seawater ionic ratios.

Ratio	Normal Sea- ¹ water	Range	Mean	99 % Confidence Interval	Percent Variance ²
Na:Cl	0.556	0.532 - 0.571	0.560	+0.008	< 1
K:Cl	0.020	0.0223 - 0.0243	0.0236	+0.0004	+18
Ca:Cl	0.021	0.0218 - 0.0230	0.0224	+0.0002	+ 6
Mg:Cl	0.067	0.0660 - 0.0684	0.0676	+0.0005	< 1
SO ₄ :Cl ³	0.140	0.102 - 0.151	0.123	+0.010	-12
HCO ₃ :Cl	0.007	0.0061 - 0.0069	0.0065	+0.0005	-13
Na:K	27.79	22.64 - 25.59	23.72	+0.57	-15
Ca:Mg	0.314	0.325 - 0.337	0.331	+0.004	+ 5

¹ Analyses are obtained from the 49th edition of the Handbook of Chemistry and Physics (1968).

² Percent variance is computed using the formula:

$$\text{Percent Variance} = \frac{(\text{Mean experimental ratio}) - (\text{Normal seawater ratio}) \times 100}{(\text{Normal seawater ratio})}$$

³ Alkalinity is expressed as bicarbonate.

Table 7. Summary of the interstitial water mean ionic ratios in different holes from Prudhoe Bay, Alaska.

Ratios	Normal Sea-1 water	Means of ratios with 99 % Confidence Intervals		
		PB 5	PB 6	PB 7
Na:Cl	0.556	0.552 ± 0.012	0.564 ± 0.027	0.551 ± 0.006
K:Cl	0.0200	0.0301 ± 0.0015	0.0301 ± 0.0043	0.0307 ± 0.0024
Ca:Cl	0.0211	0.0233 ± 0.0016	0.0273 ± 0.0022	0.0261 ± 0.0026
Mg:Cl	0.0670	0.0624 ± 0.0027	0.0656 ± 0.0025	0.0626 ± 0.0023
HCO ₃ :Cl ²	0.0075	0.0103 ± 0.0017	0.0081 ± 0.0029	0.0109 ± 0.0040
SO ₄ :Cl	0.1395	0.086 ± 0.013	0.091 ± 0.020	0.103 ± 0.011
Na:K	27.79	18.43 ± 0.95	19.06 ± 2.42	18.03 ± 1.18
Ca:Mg	0.314	0.373 ± 0.026	0.417 ± 0.045	0.416 ± 0.037

Ratios	Normal Sea-1 water	Means of ratios with 99 % Confidence Intervals		
		PB 8	PB 9	PH 25 and PH 27
Na:Cl	0.556	0.561 ± 0.007	0.487 ± 0.089	0.563 ± 0.028
K:Cl	0.0200	0.0313 ± 0.0010	0.0527 ± 0.0197	0.0287 ± 0.0045
Ca:Cl	0.0211	0.0111 ± 0.0027	0.4488 ± 0.3270	0.0241 ± 0.0012
Mg:Cl	0.0670	0.0507 ± 0.0036	0.0981 ± 0.0335	0.0658 ± 0.0042
HCO ₃ :Cl ²	0.0075	0.0449 ± 0.0088	0.9525 ± 0.9757	0.0112 ± 0.0048
SO ₄ :Cl	0.1395	0.083 ± 0.013	0.869 ± 0.956	0.132 ± 0.076
Na:K	27.79	18.19 ± 0.50	4.250 ± 1.877	19.73 ± 2.89
Ca:Mg	0.314	0.207 ± 0.037	10.81 ± 2.12	0.366 ± 0.027

¹ Analyses are obtained from the 49th edition of the Handbook of Chemistry and Physics (1968).

² Alkalinity is expressed as bicarbonate.

some other analytical error. Unfortunately, neither of these samples had sufficient water left after the first analysis to check the measurements.

The constancy of the sodium to chloride ratio, and its similarity to that for normal seawater, suggests that none of the diagenetic mechanisms which are known to affect the sodium concentration are occurring to any significant degree under the conditions that exist at Prudhoe Bay. In contrast, all of the other ions have ratios which deviate significantly from those for normal seawater. Potassium, for example, appears to be about 50 % higher in the interstitial water than in normal seawater. This enrichment is also above that found in the Prudhoe Bay seawater and is found in both the fine-grained and the coarse-grained material.

Potassium may be enriched in two ways. The first is through the weathering of potassium-rich minerals such as potassium feldspar, muscovite, or illite. At least 60 % of the clays at Prudhoe Bay are illite (Naidu and Mowatt, 1974) and X-ray diffraction studies confirm that illite and/or mica (muscovite?) are present in most of the fine-grained sediments. Siever et al. (1965) have reported that weathering of these minerals can result in the potassium concentration being raised from 0.37 to 0.54 ppt in the interstitial water, an enrichment similar to that found in Prudhoe Bay. Similar results have also been reported by Manheim (1974).

The second mechanism is due to the influence of temperature on the exchangeable cations. This "temperature effect" is discussed in Manheim and Sayles (1974), Bischoff et al. (1970), and Bischoff and Ku (1970). The exchange sites on clays are selective with respect to the ions which they adsorb. This selectivity changes with the temperature of the sediment, i.e., if a sediment's temperature was raised, proportionately more or less of an ion would be adsorbed at the higher temperature than at the lower temperature. The degree to which this variation with temperature occurs is different for each ion. For example, as the temperature is increased, potassium, sodium, and lithium become enriched in the interstitial water. Potassium shows the greatest enrichment and lithium the least. Conversely, magnesium, strontium, and calcium become depleted in the interstitial solution, with magnesium showing the greatest depletion and calcium the least. Therefore, if the temperature were raised in fine-grained samples, potassium and sodium would be enriched in the interstitial water whereas magnesium and calcium would be depleted.

In the present study, care was taken to ensure that the temperature was not markedly different from the in situ

conditions. Samples were packed in insulated boxes during shipping and were kept in a refrigerator until just prior to analysis. In spite of this, some warming of the sediment did occur during centrifugation. Bischoff et al. (1970) reported that the temperature effect may produce a potassium enrichment of up to 13.3 %. Whether or not enrichments of 50 % can occur by this mechanism is not known. In general, it is thought that some of the potassium enrichment is due to the temperature effect but that most is due to the weathering of potassium-rich minerals.

The calcium to chloride and the calcium to magnesium ratios show that calcium is also enriched by about 20 % in the interstitial water. This enrichment occurs in most of marine sediments and may be due to either cation exchange reactions or the dissolution of carbonate minerals. In Prudhoe Bay, most of the marine sediments are probably from the Sagavanirktok River, although some are undoubtedly from other sources including the adjacent coastal plain. Because the Sagavanirktok River drains through limestones in the Brooks Range, transported clays would probably have most of their exchange sites saturated with calcium. When these clays reach the Beaufort Sea, the chemical environment changes to one which is both sodium and magnesium rich.

Even if calcium were preferentially adsorbed, the law of mass action requires that some exchange with sodium, potassium, and/or magnesium occur, the result being that calcium is released into the water. This mechanism may explain why calcium is enriched in the seawater. When the clays settle to the sea floor, weathering of potassium-rich minerals would release fairly large amounts of potassium into the interstitial water. This would result in the further displacement of calcium from the exchange sites and in the observed enrichment in the interstitial water.

There are two drawbacks to this mechanism. First, it is not known whether such a mechanism can account for a 20 % enrichment in the interstitial water. And secondly, if cation exchange is relatively instantaneous, then most of the cation exchange should occur while the clays are suspended in the water column.

The magnesium to chloride ratio (Table 7) shows that magnesium is slightly depleted (about 4 %) in the interstitial water. This depletion is generally uniform throughout all of the marine holes except PB8. In PB5, there may be some decrease with depth in the marine clays, suggesting that adsorption on clays or replacement of magnesium for calcium in calcium carbonate may have occurred. These mechanisms may also account for the relative decrease in the magnesium to chloride ratios over those found in the Prudhoe Bay seawater. The relative decrease may also be the result of the temperature effect

discussed previously. Bischoff et al. (1970), for example, have reported that this effect may cause a decrease of 2.5 % in the magnesium concentration.

The bicarbonate (alkalinity) to chloride ratios (Table 7) indicate that alkalinity is significantly higher in the marine sediments (PB5, PB6, PB7, PH25, and PH27) than in normal seawater. Generally, the ratio is higher in the marine muds than in either the sands near the surface of the sea bed or the gravels underlying the marine muds. This pattern follows both the calcium carbonate and the organic carbon distributions and suggests that the higher alkalinities are the result of the oxidation of organic matter with the concurrent dissolution of calcium carbonate. When organic matter is oxidized, either chemically or biochemically, carbon dioxide gas is released. This gas reacts with water to form carbonic acid which may react with calcium carbonate to produce calcium and bicarbonate ions. The reaction is summarized below:

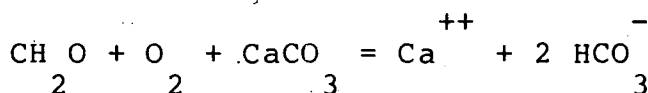

As a result, both the calcium and alkalinity concentrations are increased in the marine sediments.

The sulfate to chloride ratios (Table 7) show that sulfate is also uniformly depleted in the interstitial water of PB5, PB6, and PB7. This depletion may be explained by a mechanism similar to the one given above. In a mildly reducing environment, certain types of bacteria are known to derive the oxygen they need for the oxidation of organic matter through the reduction of sulfate ions to sulfide ions. The reaction is summarized below:

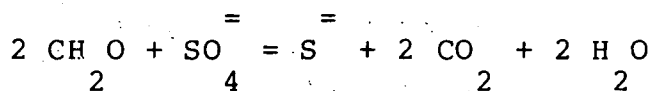

Provided that the sulfide ion does not react with hydrogen ions to form hydrogen sulfide, the increase in the carbonic acid would dissolve some calcium carbonate, causing both the alkalinity and the calcium ion concentrations to increase as the sulfate ion concentration decreases.

Holes PB8 and PB9 have not yet been included in most of the discussion because the chemical profiles for both of these holes are markedly different from the others. Figures 16 and 17 show the chemical profiles for PB8. The chloride ion concentrations (Fig. 16a) are relatively constant throughout the profile and are similar to the sodium ion distribution (Fig. 16b). Table 7 indicates that the ratios of these two ions do not vary significantly from either

normal seawater or from the other marine boreholes. Potassium is also constant throughout the profile (Fig. 16c) and appears to be relatively enriched in the sediments over the concentration found in the overlying seawater. This enrichment, however, is not significantly different from that for the other marine boreholes, as the potassium to chloride and the sodium to potassium ratios in Table 7 indicate. On the basis of these three ions, it can be assumed that the water in PB8 was originally similar to the water in the other three marine boreholes.

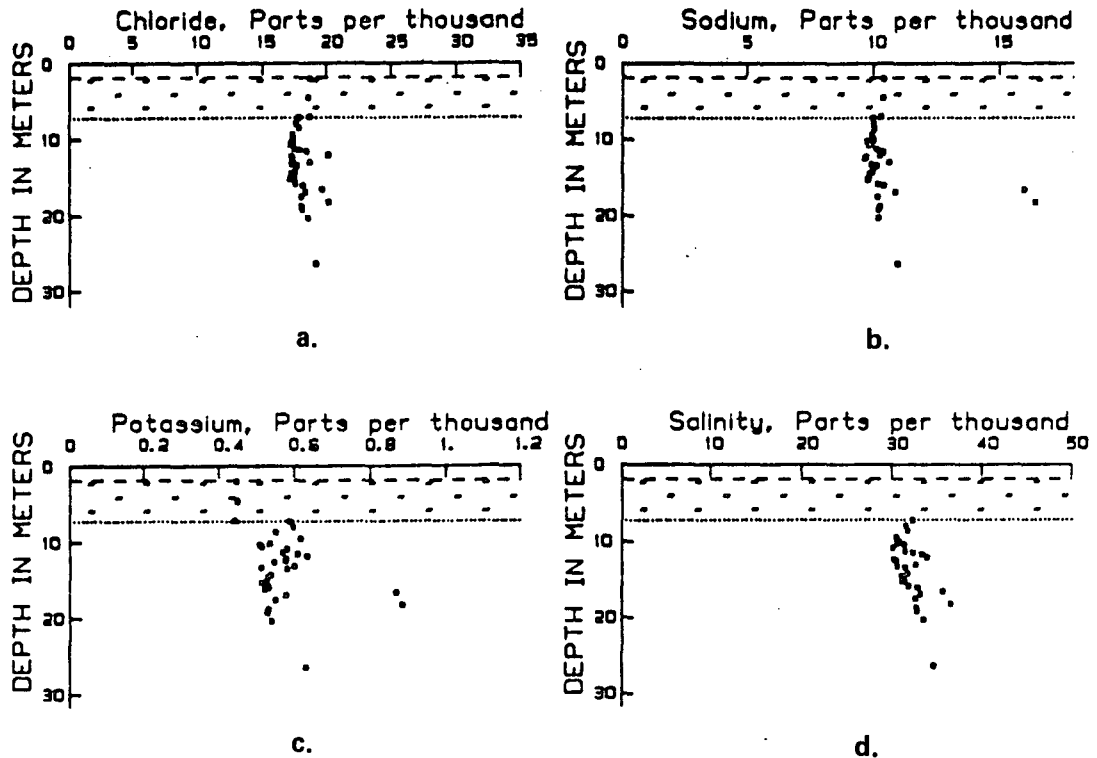

Figure 16. Chloride, sodium, potassium, and salinity as a function of depth for borehole PB8.

Figures 17a, 17b, and 17c show the calcium, magnesium, and sulfate concentrations with depth. In the sediments at the surface of the sea bed, all of these ions have concentrations which are very close to those found in the overlying seawater. However, immediately below the sediment/water interface the concentrations decrease rapidly to a minimum at a depth of 5 to 6.5 m (12 to 13.5 m below the sea ice surface). At this depth, the calcium, sulfate, and magnesium concentrations are respectively about 25 %, 36 %, and 60 % of the concentrations found in the surficial sediments. At greater depths, the concentrations only gradually increase down to a depth of about 9 to 9.5 m (16 to 16.5 m below the sea ice surface), below which they increase more rapidly.

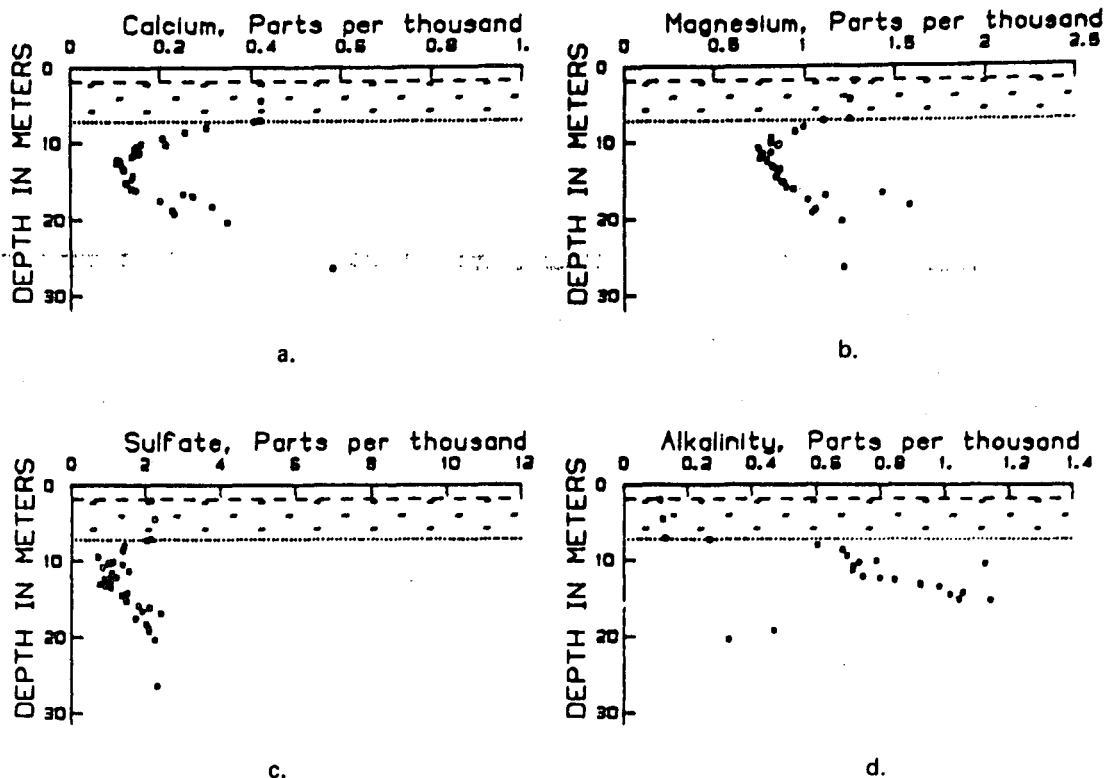
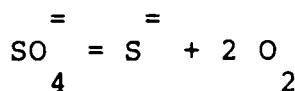
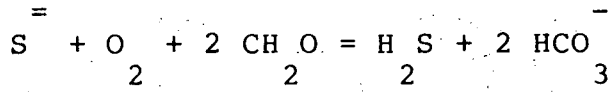

Figure 17. Calcium, magnesium, sulfate, and alkalinity as a function of depth for borehole PB8.

In contrast to the calcium, magnesium, and sulfate ions, the alkalinity increases down to a depth of 9 to 9.5 m below the sediment/water interface (Fig. 17d). Concentrations of up to 9 times that found in the overlying seawater were measured. These high alkalinities are reflected in the bicarbonate to chloride ratios in Table 7. The average ratio for PB8 is more than 4 times that of any other hole.

These distributions may be due to the oxidation of organic matter in a reducing environment. Just prior to analysis, many of the sediment samples had a rind of lighter colored sediment surrounding a much darker inner core. This rind was probably caused by the oxidation of reduced chemical species, such as ferrous iron, and suggests that the original sediments were reducing in nature. Under these conditions, bacteria obtain oxygen for the oxidation of organic matter by converting sulfate ions to sulfide ions. The reaction may be summarized as follows:





As a result of this reaction, the alkalinity of the water would increase and would further react with calcium and/or magnesium to form calcium and/or calcium-magnesium carbonates. X-ray diffraction studies on the sediments indicate that both calcite (calcium carbonate) and dolomite (calcium-magnesium carbonate) are present in the sediments. However, because the Sagavanirktok River drains through both limestones and dolomites in the Brooks Range, these minerals may also be detrital.

Part of the decrease in magnesium may also be due to the recrystallization of calcium carbonate to dolomite. This recrystallization could occur either by the simple replacement of magnesium for calcium, with a net increase in the calcium concentration of the interstitial water, or by the recrystallization of calcite to dolomite, with the net loss of alkalinity. The reactions are listed below.

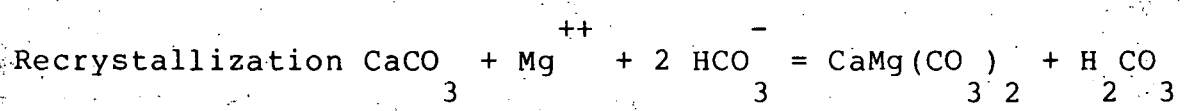
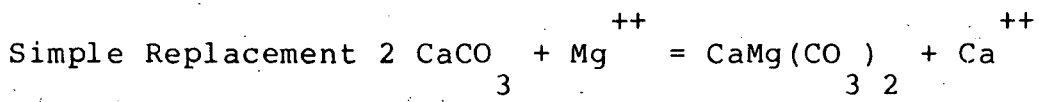

For PB8, the second mechanism is more likely to have occurred because bicarbonate ion would be consumed.

PB9 is different from the other holes primarily because it is located on land. Table 7 indicates that all ions are, on the average, enriched relative to the chloride ion concentration with the exception of sodium, which is depleted (cf. O'Sullivan, 1963). In the surficial sediments down to a depth of about 0.3 m, the solutions consist of predominantly sodium, calcium, and chloride, suggesting that these ions may have been derived from sea spray. Underneath this layer, the salt content drops rapidly and the composition of the solution changes to one which is dominated by calcium, sulfate, and bicarbonate ions. This zone is probably characterized by leaching of the more soluble salts. Below a depth of about 1.5 to 3 m, the composition becomes progressively more like that of normal seawater, with sodium and chloride being the dominant ions.

It is likely that the interstitial water in the bottom of PB9 is relict seawater rather than seawater which has recently infiltrated into the permeable sands and gravels. During the Sangamon interglaciation, most of the coastal areas of the Arctic Coastal Plain were inundated by the

Arctic Ocean (or Beaufort Sea), and it is likely that most of the pore spaces in the sediments were filled with seawater. As the coastal plain emerged from the sea at the beginning of the Wisconsin, permafrost developed in the sediments and "sealed in" the marine interstitial water composition. Freezing and thawing, weathering, leaching, and the influx of fresh water would cause the composition of the pore water to change in the surface layer of sediment. However, below the freezing and thawing layer, little change in the interstitial water composition would be expected. The sodium to chloride ratios in the sediments below a depth of 3 m (Table 5) tentatively support this hypothesis. If, on the other hand, the higher concentrations at depth were due to the recent influx of seawater into the permeable sands and gravels, then water in these sediments would have to be mobile. Osterkamp and Harrison (1976) have published temperature data for hole -226 (Fig. 3) which suggest that all of the sediments in PB9 should have temperatures well below -5°C . At these temperatures, water of the salinity found in PB9 should be entirely frozen, and water movement would be impeded.

Comparison with other Studies

In general, most of the results described above compare well with those of other studies. Iskandar et al. (1978), for example, have reported chemical analyses for holes PB1, PB2, and PB3 (Fig. 3). PB3 lies mid-way between PB7 and PB8, and the seawater composition found at PB3 should be close to that found at the other two stations. Table 8 shows the seawater compositions for PB3, PB7, and PB8 as well as that for normal seawater. On the whole, these values agree well for sulfate, alkalinity, and potassium. Calcium at PB3 is slightly lower than that found at either PB7 or PB8 and may have resulted from calcium carbonate precipitation during transportation back to CRREL in Hanover, N.H., where the analyses reported in Iskandar et al. (1978) were conducted. Magnesium values at PB3 appear to be substantially lower than those found either in normal seawater or at PB7 and PB8. The reason for these lower values is not known, but they may be due to sample handling and/or analytical errors. Conductivity data at PB7 and PB8 are lower than at PB3. Given the chloride data, these conductivities appear to be too low and were probably due to an instrumental error.

Table 9 shows a comparison of the interstitial water analyses for PB3 and PB7. Generally, the analyses agree well for sulfate, alkalinity, potassium, and calcium. The pH data at PB3 are slightly lower than those found at PB7, but this may not be significant when compared to analytical precision. Conductivities at PB3 also appear to be lower than those found at PB7. However, a glance at the profiles (Fig. 18) shows that the data for the two stations are

Table 8. Seawater ionic concentrations for PB3, PB7, and PB8.

Parameter ¹	PB3 (Iskandar et al., 1978)	This Study PB7 and PB8	Normal Sea- ² water
Chloride		18.57 - 19.56	18.980
Sulfate	2.2 - 2.4	2.15 - 2.57	2.648
Bicarbonate	0.1	0.11 - 0.13	0.142
Sodium		10.34 - 10.93	10.561
Potassium	0.49 - 0.52	0.44 - 0.46	0.380
Calcium	0.20 - 0.30	0.42 - 0.44	0.400
Magnesium	0.45 - 0.60	1.25 - 1.32	1.272 ³
Conductivity	53.04 - 53.13	44.21 - 50.81	53

¹ All ionic concentrations are in parts per thousand. Conductivity is in millimhos per centimeter, corrected to 25°C.

² Analyses are obtained from the 49th edition of the Handbook of Chemistry and Physics (1968).

³ Iskandar et al. (1978).

Table 9. Interstitial water ionic concentrations and ratios for PB3 and PB7.

Parameter ¹	PB3 (Iskandar et al., 1978)	This Study PB7	Normal Sea- ² water
pH	7.30 - 7.95	7.67 - 8.14	
Conductivity	41.30 - 55.37	47.12 - 61.06	³ 53
Chloride	12.0 - 20.0	18.12 - 24.94	18.980
Sulfate	2.0 - 2.7	1.82 - 2.58	2.648
Bicarbonate	0.1 - 0.3	0.12 - 0.39	0.142
Sodium		10.01 - 13.94	10.561
Potassium	0.45 - 0.85	0.54 - 0.81	0.380
Calcium	0.20 - 0.30	0.37 - 0.69	0.400
Magnesium	0.31 - 0.70	1.13 - 1.52	1.272
<u>Ion to chloride ratios</u>			
Potassium	0.0280 - 0.0559	0.0289 - 0.0381	0.0200
Calcium	0.0106 - 0.0462	0.0204 - 0.0299	0.0211
Magnesium	0.0204 - 0.0467	0.0562 - 0.0650	0.0670
Sulfate	0.1075 - 0.1929	0.085 - 0.117	0.1395
Bicarbonate	0.0053 - 0.0161	0.0049 - 0.0186	0.0075

¹
All ionic concentrations are in parts per thousand.
Conductivity is in millimhos per centimeter, corrected to 25°C.

²
Analyses are obtained from the 49th edition of the Handbook of Chemistry and Physics (1968).

³
Iskandar et al. (1978).

comparable.

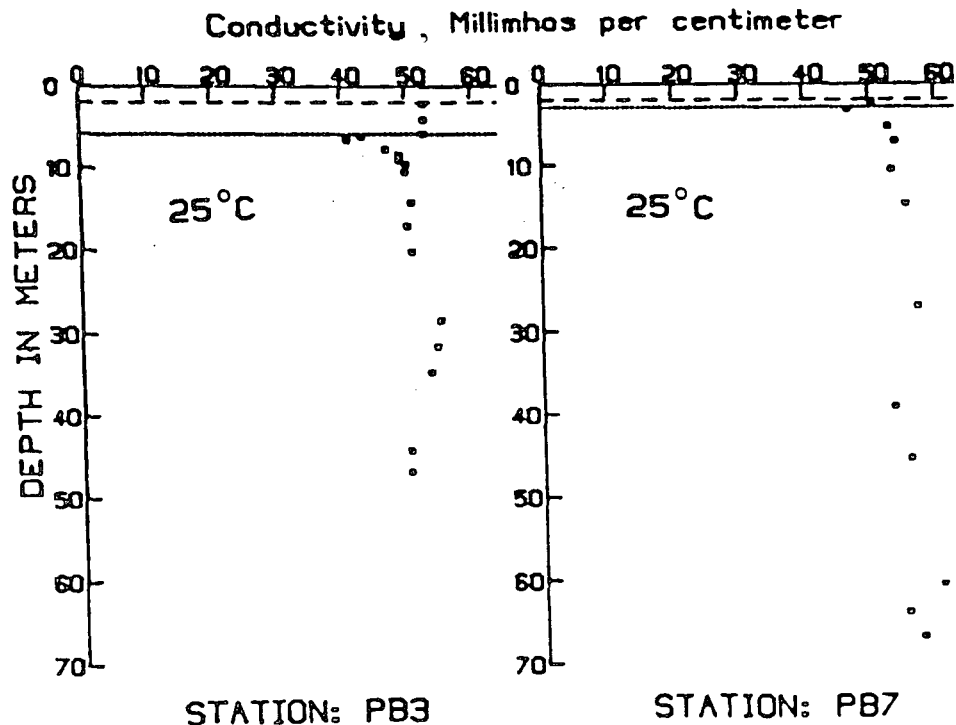

Figure 18. Conductivity as a function of depth for PB3 and PB7. Data for PB3 from Iskandar et al. (1978).

The magnesium and chloride concentrations for PB3 are also lower than those found at PB7. The magnesium concentrations at PB3 are about half those observed at PB7 and the magnesium to chloride ratios (Table 9) are lower than those for normal seawater. These lower values may be due to the adsorption of magnesium on clays. Chloride ion concentrations appear to be about 5 ppt lower at PB3 than at PB7 (Fig. 19) and the ratios of potassium, calcium, and sulfate to chloride are higher than those for normal seawater. These lower chloride concentrations may be due to differences between the two collection sites or to analytical errors.

In addition to the findings of Iskandar et al. (1978), Osterkamp and Harrison (1976) have reported chemical analyses for holes 191, 481, and 3370 (Fig. 3). These analyses were performed by a commercial laboratory and some of the values agree well with the data presented here. However, major differences occur in the sodium, potassium, magnesium, and chloride concentrations. Osterkamp and Harrison have questioned the results, suggesting that evaporative loss during transport, contamination from the drilling mud, and/or analytical errors may have caused the

results to be significantly different from those of normal seawater.

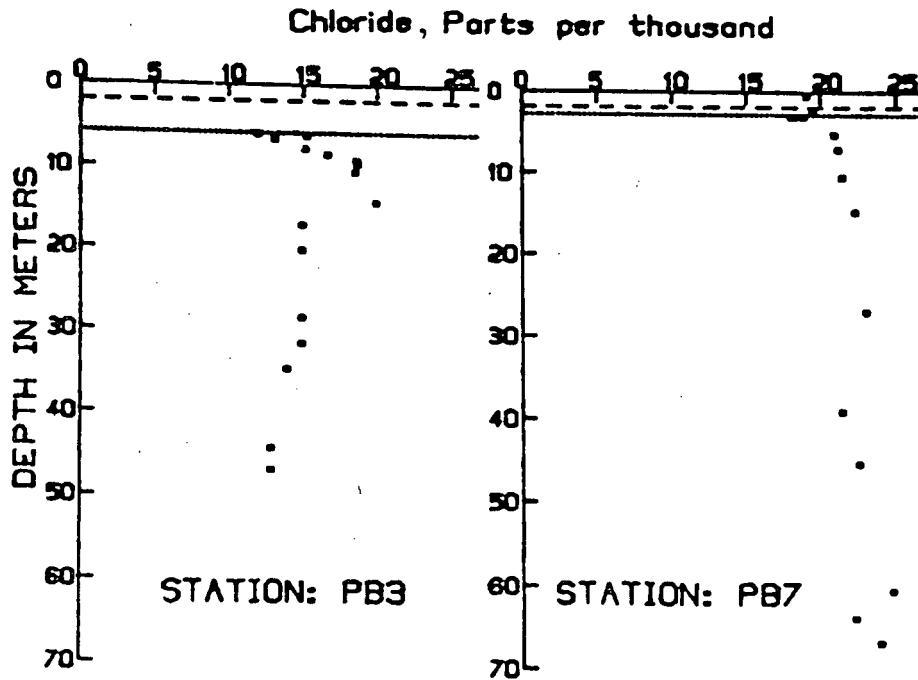

Figure 19. Chloride concentration as a function of depth for PB3 and PB7. Data for PB3 from Iskandar et al. (1978).

Summary and Conclusions

- 1- The sediments in Prudhoe Bay consist of a thin layer of marine muds overlying glacial and fluvial gravels. Generally, the muds are calcareous and contain relatively high amounts of both interstitial water and organic carbon whereas the gravels contain lower amounts of these substances. On land, the marine muds are absent and in their place are sands and silts containing abundant amounts of peat. Water and organic carbon contents in these latter sediments were much higher than those found offshore.
- 2- During the early spring of 1977, seawater in Prudhoe Bay varied in salinity from 33.4 to 57.3 parts per thousand (ppt). The higher salinities were found near the shore where sea ice is frozen directly to, or is located near, the sea bottom, or where circulation with more open water is restricted. These brines probably resulted from salt exclusion during the formation of sea ice. The lower salinities were found further offshore and were approximately 1.0 to 1.5 ppt less saline than normal seawater. Work by other investigators in different areas of the continental shelf suggest that these salinities are characteristic of the upper 200 m of the Beaufort Sea for this time of year.

Temperature in the Prudhoe Bay seawater samples was inferred to vary from -2.95°C near the shore to -1.8°C further offshore. These values were obtained by calculating the freezing points from the salinity data and assuming that all of the seawater samples were in equilibrium with the sea ice.

Chemical analyses of the seawater samples showed that sodium, magnesium, and chloride ions were all present in the same proportions as for normal seawater. Calcium and potassium were enriched relative to the chloride ion concentration by about 6 and 18 %, respectively, whereas alkalinity and sulfate were both depleted by about 12 to 13 %. No general explanation for these deviations from the composition of normal seawater can be offered at this time.

- 3- The salinity of the interstitial water in the sediments was highest near the shore where seawater, consisting of highly concentrated brines, infiltrated into the surficial layer of sediment. Highly saline water was also found immediately below sediments near the surface of the sea bed in which some of the interstitial water was believed to be frozen. All of the interstitial water samples had a sodium to chloride ratio similar to that for normal seawater, suggesting that the interstitial

water had been originally seawater which had either infiltrated into, or been deposited with, the sediments.

In sediments inferred to be mildly reducing, relatively more potassium, calcium, and alkalinity, and less sulfate and magnesium, are found in the interstitial water than in normal seawater. These changes in the pore water composition are thought to result from the oxidation of organic carbon, cation exchange reactions, dissolution of calcium carbonate, weathering of potassium-rich minerals, reduction of sulfate by bacteria, and possibly replacement of magnesium for calcium in calcium carbonate. In more strongly reducing sediments, relatively more potassium and alkalinity, and less calcium, magnesium, and sulfate, are found in the interstitial water than in normal seawater. These variations may be due to the recrystallization of calcium carbonate to dolomite and the precipitation of calcium and/or calcium-magnesium carbonates in addition to most of the other mechanisms given above.

4- On land, the salinity of the interstitial water varies from 0.5 to 12.5 ppt. In the peat layer located in the upper 2 to 3 m of the sediment column, salinity is less than 1.5 ppt and the composition of the water is predominated by calcium, bicarbonate, and sulfate ions. This layer is probably characterized by freezing and thawing, leaching, weathering, and infiltration of fresh water from the surface. Below a depth of about 3 m, the salinity gradually increases with depth and the interstitial water becomes more like normal seawater in composition. This water probably represents relict seawater that was trapped as a result of the development of permafrost in the sediments shortly after the area emerged from the sea.

5- In the boreholes drilled offshore, evidence of frozen water was found in most of the sediments located near the surface of the sea bed. This frozen layer of sediments was up to 3.5 m thick and is believed to develop annually during the winter months. Because the sediments lacked visible ice crystals and because resistance to penetration during either drilling operations or penetration tests was not markedly different from that in unfrozen sediments, it is inferred that the sediments located near the surface of the sea bed were only partially frozen and were not ice-bonded. Penetration tests in shallower water (less than 1.5 m), however, indicated that the sediments there were bonded to a much greater degree. Concentrated brines were found immediately beneath the partially frozen layer and are thought to result from salt exclusion during the freezing of the interstitial water.

6- Ice-bonded permafrost was encountered in boreholes PB6 and PB7, at depths of approximately 30.5 and 62 m, respectively. This conclusion was based on the calculated freezing points, the borehole temperature data, the increased resistance to casing installation at these depths, and the physical examination of samples from PB6. Visible ice was not observed.

On land, ice crystals and ice lenses were found in the peat layer down to a depth of about 3 m. Below this depth, no visible ice crystals were reported; this may have been due to the thermal and mechanical disturbance caused by drilling.

Literature Cited

- American Public Health Association, 1971, Standard Methods for the Examination of Water and Wastewater, Thirteenth Edition, M.J. Tares, A.E. Greenberg, R.D. Hoak, and M.C. Rand, editors: Prepared and published jointly by the American Public Health Association, the American Water Works Association, and the Water Pollution Control Federation, Washington, D.C.
- Barnes, P.W., and Reimnitz, E., 1974, Sedimentary processes on arctic shelves off the northern coast of Alaska: in The Coast and Shelf of the Beaufort Sea, Proceedings of a Symposium on Beaufort Sea Coast and Shelf Research, J.C. Reed and J.E. Sater, editors, Arctic Institute of North America, San Francisco, California, p. 439-476.
- Bischoff, J.L., Greer, R.E., and Luistro, A.O., 1970, Composition of interstitial waters of marine sediments: Temperature of squeezing effect: Science, v. 167, p. 1245-1246.
- _____, and Ku, T.L., 1970, Pore fluids of recent marine sediments, II. Anoxic sediments of 35 to 45°N, Gibraltar to Mid-Atlantic Ridge: Journal of Sedimentary Petrology, v. 41, no. 4, p. 1008-1017.
- Black, R.F., 1964, Gubik Formation of Quaternary age in northern Alaska: U.S. Geological Survey Professional Paper, No. 302-C, p. 59-91.
- Bremner, J.M., and Jenkinson, D.S., 1960, Determination of organic carbon in soil, I. Oxidation by dichromate of organic matter in soil and plant materials: Journal of Soil Science, v. 11, no. 2, p. 394-402.
- Brown, J., 1969, Ionic concentration gradients in permafrost, Barrow, Alaska: U.S. Army Cold Regions Research and Engineering Laboratory Research Report, No. 272, 26 p.
- _____, Haugan, R.K., and Parrish, S., 1975, Selected climatic and soil thermal characteristics of the Prudhoe Bay region: in Ecological Investigations of the Tundra Biome in the Prudhoe Bay Region, Alaska, J. Brown, editor, Biological Papers of the University of Alaska, Special Report No. 2, p. 2-11.
- Burrell, D.C., Dygas, J.A., and Tucker, R.W., 1973, Beach morphology and sedimentology of Simpson Lagoon: in Environmental Studies of an Arctic Estuarine System, Final Report by V. Alexander et al., Sea Grant Report No. 73-16, Institute of Marine Science, University of Alaska, Fairbanks, Alaska, p. 45-143.

- Chamberlain, E.J., Sellmann, P.V., Blouin, S.E., Hopkins, D.M., and Lewellen, R.I., 1978, Engineering properties of subsea permafrost in the Prudhoe Bay region of the Beaufort Sea: Proceedings of the Third International Conference on Permafrost, July 10-13, 1978, Edmonton, Alberta, Canada, vol. 1, p. 629-635.
- Fujino, K., Lewis, E.L., and Perkins, R.G., 1974, The freezing point of seawater at pressures up to 100 bars: Journal of Geophysical Research, v. 79, no. 12, p. 1792-1797.
- Gold, L.W., and Lachenbruch, A.H., 1973, Thermal conditions in permafrost - A review of North American literature: in North American Contribution, Second International Conference on Permafrost, National Academy of Sciences, Washington, D.C., p. 3-25.
- Hamilton, T.D., and Porter, S.C., 1975, Itkillik glaciation in the Eriks Range, northern Alaska: Quaternary Research, v. 5, p. 471-497.
- Handbook of Chemistry and Physics, 49th edition, R.C. Weast, editor, 1968: The Chemical Rubber Co., Cleveland, Ohio.
- Handbook of Chemistry and Physics, 57th edition, R.C. Weast, editor, 1976: The Chemical Rubber Co., Cleveland, Ohio.
- Hopkins, D.M., 1967, Quaternary marine transgressions in Alaska: in The Bering Land Bridge, D.M. Hopkins, editor, Stanford University Press, Stanford, California, p. 47-60.
- Hufford, G.L., 1973, Warm water advection in the southern Beaufort Sea, August-September, 1971: Journal of Geophysical Research, v. 78, no. 15, p. 2702-2707.
- _____, 1974, Dissolved oxygen and nutrients along the north Alaskan shelf: in The Coast and Shelf of the Beaufort Sea, Proceedings of a Symposium on Beaufort Sea Coast and Shelf Research, J.C. Reed and J.E. Sater, editors, Arctic Institute of North America, San Francisco, California, p. 567-588.
- Hume, J.D., and Schalk, M., 1967, Shoreline processes near Barrow, Alaska: A comparison of the normal and the catastrophic: Arctic, v. 20, no. 2, p. 86-103.
- _____, and Hume, P.W., 1972, Short-term climate changes and coastal erosion, Barrow, Alaska: Arctic, v. 25, no. 4, p. 272-278.
- Iskandar, I.K., Osterkamp, T.E., and Harrison, W.D., 1978, Chemistry of interstitial water from subsea permafrost,

- Prudhoe Bay, Alaska: Proceedings of the Third International Conference on Permafrost, July 10-13, 1978, Edmonton, Alberta, Canada, vol. 1, p. 92-98.
- Kovacs, A., and Mellor, M., 1974, Sea ice morphology and ice as a geological agent in the southern Beaufort Sea: in The Coast and Shelf of the Beaufort Sea, Proceedings of a Symposium on Beaufort Sea Coast and Shelf Research, J.C. Reed and J.E. Sater, editors, Arctic Institute of North America, San Francisco, California, p. 113-161.
- Leffingwell, E. deK., 1908, Flaxman Island, a glacial remnant: Journal of Geology, v. 16, p. 56-63.
- _____, 1919, The Canning River region, northern Alaska: U.S. Geological Survey Professional Paper, No. 109, 251 p.
- Lewellen, R.I., 1970, Permafrost erosion along the Beaufort Sea coast: University of Denver (Colorado), Department of Geography and Geology Publication, 25 p., 34 figures.
- _____, 1972, The occurrence and characteristics of nearshore permafrost, northern Alaska: Progress report for the Arctic Institute of North America.
- _____, 1973, The occurrence and characteristics of nearshore permafrost, northern Alaska: in North American Contribution, Second International Conference on Permafrost, National Academy of Sciences, Washington, D.C., p. 131-136.
- _____, 1974, Offshore permafrost, Beaufort Sea, Alaska: in The Coast and Shelf of the Beaufort Sea, Proceedings of a Symposium on Beaufort Sea Coast and Shelf Research, J.C. Reed and J.E. Sater, editors, Arctic Institute of North America, San Francisco, California, p. 417-426.
- Lind Jr., J.E., Zwolenik, J.J., and Fross, R.M., 1959, Calibration of conductance cells at 25°C with aqueous solutions of potassium chloride: Journal of the American Chemical Society, v. 81, p. 1557.
- MacCarthy, G.R., 1958, Glacial boulders on the arctic coast of Alaska: Arctic, v. 11, no. 2, p. 70-85.
- MacKay, J.R., 1972, Offshore permafrost and ground ice, southern Beaufort Sea, Canada: Canadian Journal of Earth Sciences, v. 9, no. 11, p. 1550-1561.
- McCulloch, D.S., 1967, Quaternary geology of the Alaskan shore of Chukchi Sea: in The Bering Land Bridge, D.M. Hopkins, editor, Stanford University Press, Stanford,

- California, p. 91-120.
- Manheim, F.T., 1974, Interstitial waters in sediments: in Encyclopedia of Geochemistry and Environmental Sciences, R.W. Fairbridge, editor, Van Nostrand-Reinhold, New York.
- _____, and Sayles, F.L., 1974, Composition and origin of interstitial waters of marine sediments, based on deep sea drill cores: in The Sea, Ideas and Observations on Progress in the Study of the Seas, E.D. Goldberg, editor, Wiley Interscience, v. 5, p. 527-568.
- Mountain, D.G., 1974, Preliminary analysis of Beaufort shelf circulation in summer: in The Coast and Shelf of the Beaufort Sea, Proceedings of a Symposium on Beaufort Sea Coast and Shelf Research, J.C. Reed and J.E. Sater, editors, Arctic Institute of North America, San Francisco, California, p. 27-42.
- Naidu, A.S., and Mowatt, T.C., 1973, Aspects of size distributions, mineralogy and geochemistry of deltaic and adjacent shallow marine sediments, north arctic Alaska: in Environmental Studies of an Arctic Estuarine System, Final Report, by V. Alexander et al., Sea Grant Report No. 73-16, Institute of Marine Science, University of Alaska, Fairbanks, Alaska, p. 145-207.
- _____, 1974, Clay mineralogy and geochemistry of continental shelf sediments of the Beaufort Sea: in The Coast and Shelf of the Beaufort Sea, Proceedings of a Symposium on Beaufort Sea Coast and Shelf Research, J.C. Reed and J.E. Sater, editors, Arctic Institute of North America, San Francisco, California, p. 493-510.
- Namtvedt, T., Parrish, S., Friese, N., and Quirk, W., 1974, The Alaskan arctic coast, a background study of available knowledge: prepared for the U.S. Army Corps of Engineers, Alaska District, Anchorage, Alaska by the Arctic Institute of North America, Alaska Office, Anchorage, Alaska.
- National Academy of Sciences, 1976, Problems and Priorities in Offshore Permafrost Research: prepared by the Ad Hoc Study Group on Offshore Permafrost of the Committee on Permafrost, Polar Research Board, Washington, D.C., 43 p.
- O'Rourke, J.C., 1974, Inventory of physical oceanography of the eastern Beaufort Sea: in The Coast and Shelf of the Beaufort Sea, Proceedings of a Symposium on Beaufort Sea Coast and Shelf Research, J.C. Reed and J.E. Sater, editors, Arctic Institute of North America, San Francisco, California, p. 65-84.

Osterkamp, T.E., and Harrison, W.D., 1976, Annual Report, offshore permafrost: drilling, boundary conditions, properties, processes and models: prepared for the U.S. Department of Commerce, National Oceanographic and Atmospheric Administration, Environmental Research Laboratories, Boulder, Colorado, 80302, by the Geophysical Institute, University of Alaska, Fairbanks, Alaska.

O'Sullivan, J.B., 1963, Geochemistry of permafrost: Barrow, Alaska: in Proceedings of the International Conference on Permafrost, Purdue University, Lafayette, Indiana, National Academy of Sciences-National Research Council, Washington, D.C., p. 30-37.

Payne, T.G., Dana, S.W., Fischer, W.A., Yuster, S.T., Krynine, P.D., Morris, R.H., Lathram, E.H., Gyrc, G., and Tappan, H., 1951, Geology of the arctic slope of Alaska: U.S. Geological Survey Oil and Gas Investigations Map, OM126, 3 sheets.

Péwé, T.L., 1975, Quaternary Geology of Alaska: U.S. Geological Survey Professional Paper, No. 835, 145 p.

Presley, B.J., and Kaplan, I.R., 1968, Changes in dissolved sulfate, calcium and carbonate from interstitial waters of near shore sediments: Geochimica et Cosmochimica Acta, v. 32, no. 10, p. 1037-1048.

Reimnitz, E., Barnes, P.W., Forgatsch, T., and Rodeick, C., 1972, Influence of grounding ice on the arctic shelf of Alaska: Marine Geology, v. 13, p. 323-334.

_____, and Bruder, K.F., 1972, River discharge into an ice-covered ocean and related sediment dispersal, Beaufort Sea, coast of Alaska: Bulletin of the Geological Society of America, v. 83, no. 3, p. 861-866.

_____, Rodeick, C.A., and Wolf, S.C., 1974, Strudel scour: a unique arctic marine geologic phenomenon: Journal of Sedimentary Petrology, v. 44, no. 2, p. 409-420.

Richards, L.A., editor, 1954, Diagnosis and Improvement of Saline and Alkali Soils: United States Salinity Laboratory Staff, Agricultural Handbook No. 60, U.S. Department of Agriculture, Washington, D.C.

Scheide, E.P., and Durst, R.A., 1977, Indirect determination of sulfate in natural waters by ion-selective electrode: Analytical Letters, v. 10, no. 1, p. 55-65.

Schell, D.M., 1973, Seasonal variation in the nutrient chemistry and conservative constituents in coastal

- Alaskan Beaufort Sea waters: in Environmental Studies of an Arctic Estuarine System, Final Report, by V. Alexander et al., Sea Grant Report No. 73-16, Institute of Marine Science, University of Alaska, Fairbanks, Alaska, p. 217-281.
- Sellmann, P.V., Carey, K.L., Keeler, C., and Hartwell, A.D., 1972, Terrain and coastal conditions on the arctic Alaskan coastal plain: U.S. Army Cold Regions Research and Engineering Laboratory Special Report, No. 165, Arctic Environmental Data Package Supplement 1.
- _____, Chamberlain, E., Ueda, H.T., Blouin, S.E., Garfield, D., and Lewellen, R.I., 1977, Operational Report, 1977. CRREL-USGS subsea permafrost program, Beaufort Sea, Alaska: U.S. Army Cold Regions Research and Engineering Laboratory Special Report, No. 77-41, 22 p.
- Shepard, F.P., 1954, Nomenclature based on sand-silt-clay ratios: Journal of Sedimentary Petrology, v. 24, p. 151-158.
- Short, A.D., Coleman, J.M., and Wright, L.D., 1974, Beach dynamics and nearshore morphology of the Beaufort Sea coast, Alaska: in The Coast and Shelf of the Beaufort Sea, Proceedings of a Symposium on Beaufort Sea Coast and Shelf Research, J.C. Reed and J.E. Sater, editors, Arctic Institute of North America, San Francisco, California, p. 477-488.
- _____, and Wiseman Jr., W.J., 1975, Coastal breakup in the Alaskan Arctic: Bulletin of the Geological Society of America, v. 86, no. 2, p. 199-202.
- Siever, R., Beck, K.C., and Berner, R.A., 1965, Composition of interstitial waters of modern sediments: The Journal of Geology, v. 73, no. 1, p. 39-73.
- UNESCO, 1966, Second report of the joint panel on oceanographic tables and standards: UNESCO Technical Papers in Marine Science, No. 4, 9 p.
- Wahrhaftig, C., 1965, Physiographic Divisions of Alaska: U.S. Geological Survey Professional Paper, No. 482, 52 p.
- Walker, H.J., 1974, The Colville River and the Beaufort Sea: some interactions: in The Coast and Shelf of the Beaufort Sea, Proceedings of a Symposium on Beaufort Sea Coast and Shelf Research, J.C. Reed and J.E. Sater, editors, Arctic Institute of North America, San Francisco, California, p. 513-540.
- Walkley, A., and Black, I.A., 1934, An examination of the Degtjareff method for determining soil organic matter,

and a proposed modification of the chromic acid titration method: Soil Science, v. 37, p. 29-38.

Weller, G., 1976, Outer Continental Shelf Environmental Assessment Program in the Beaufort Sea: Arctic Bulletin, v. 2, no. 9, p. 125-142.

_____, Norton, D., and Johnson, T., editors, 1977, Environmental Impacts of Outer Continental Shelf development in Northern Alaska, Proceedings of a "Synthesis Meeting" of Outer Continental Shelf Environmental Assessment Program and other investigators working in northern Alaska, Barrow, Alaska, 7-11 February 1977: Arctic Project Bulletin, Outer Continental Shelf Environmental Assessment Program, Special Bulletin No. 15, Draft of the Beaufort Sea Synthesis Report.

APPENDIX

Chemical analyses of interstitial and seawater samples from Prudhoe Bay, Alaska; in milliequivalents per liter.

SAMPLES	DEPTH	+		++		Cl	SO ₄	HCO ₃
		Na	K	Ca	Mg			
PB5 WC-1	1.80	547.5	15.8	25.5	125.5	647.7	34.2	3.5
PB5 WC-2	1.94	540.9	15.5	27.2	120.7	618.7	43.7	3.1
PB5 WC-3	2.16	464.4	15.0	25.1	101.2	545.9	44.5	3.8
PB5 WC-4	3.34	463.5	15.2	22.0	95.7	550.5	29.2	3.4
PB5 WC-5	6.50	479.8	16.0	23.2	101.3	559.9	32.5	3.4
PB5 WC-6	6.90	483.3	15.8	22.1	99.5	563.6	46.7	4.2
PB5 WC-7	4.10	439.2	15.0	21.1	89.1	550.5	31.4	3.9
PB5 WC-8	8.11	520.0	16.8	21.9	103.4	593.4	50.1	3.8
PB5 WC-9	9.20	483.6	14.6	23.9	109.2	580.4	31.1	4.0
PB5 WC-10	9.70	480.3	14.8	22.1	107.3	559.4	33.4	4.0
PB5 WC-11	10.35	480.9	15.6	21.4	106.2	571.0	31.0	3.2
PB5 WC-12	10.85	578.0	20.0	31.6	120.4	671.8	41.7	2.5
PB5 WC-13	11.33	586.7	19.4	29.9	120.3	668.3	39.2	2.7
PB6 WC-14	1.90	647.3	19.2	34.1	141.2	753.2	54.1	2.9
PB6 WC-15	2.15	470.4	12.4	23.2	94.7	483.9	32.6	4.2
PB6 WC-16	2.30	541.4	14.4	28.6	129.7	633.9	53.6	3.8
PB6 WC-17	2.93	612.4	20.1	31.7	138.7	721.0	54.7	3.9
PB6 WC-18	3.40	642.8	22.6	33.5	138.9	699.9	62.2	3.6
PB6 WC-19	3.63	622.1	22.9	33.2	133.2	700.6	55.0	3.5
PB6 WC-20	4.10	590.0	18.1	34.2	137.8	703.3	46.8	3.6
PB6 WC-21	4.56	775.8	30.2	43.1	164.1	883.0	51.0	3.9
PB6 WC-22	6.79	766.0	23.0	42.6	178.3	914.8	41.0	3.2
PB6 WC-23	29.72	481.7	15.2	29.6	103.1	579.4	37.0	1.7
PB6 WC-24	30.87	598.3	15.7	42.3	131.3	718.2	27.9	1.4
PB7 WC-25	2.91	435.5	13.8	23.0	93.3	511.1	44.3	3.8
PB7 WC-26	3.03	437.8	13.7	18.6	96.4	516.7	39.0	5.4
PB7 WC-27	5.15	506.8	16.0	25.9	110.0	591.5	51.7	6.4
PB7 WC-28	6.92	509.7	20.7	27.6	103.3	599.9	37.8	4.4
PB7 WC-29	10.25	510.1	15.9	30.2	111.0	606.4	37.8	5.0
PB7 WC-31	14.56	527.9	16.8	33.1	118.5	633.5	44.9	3.8
PB7 WC-33	26.70	541.7	18.1	34.5	122.5	653.0	52.3	3.5
PB7 WC-34	38.98	521.6	15.9	28.8	114.9	606.4	52.5	2.8
PB7 WC-35	45.07	542.0	18.3	32.6	118.2	639.0	45.1	3.3
PB7 WC-36	60.45	606.2	20.6	29.8	125.3	703.4	53.8	2.0
PB7 WC-37	63.60	535.7	16.3	29.3	119.3	632.5	51.5	2.3
PB7 WC-38	66.56	586.0	19.4	27.3	111.5	680.2	47.1	2.8
PB8 WC-39	7.22	437.0	15.1	20.3	90.7	503.0	42.6	4.4
PB8 WC-40	7.97	437.0	15.3	15.1	81.9	496.0	30.0	9.9
PB8 WC-41	8.62	438.8	14.1	12.8	77.9	503.0	29.0	11.2
PB8 WC-42	9.47	434.5	15.8	10.3	67.3	491.7	15.4	11.4
PB8 WC-43	10.08	436.8	13.8	8.1	66.9	488.9	23.9	12.9
PB8 WC-44	10.27	425.1	13.0	10.7	71.0	493.3	20.9	12.1
PB8 WC-45	10.48	432.6	13.2	7.6	69.9	490.9	29.3	18.5
PB8 WC-46	10.82	428.7	14.9	7.3	61.1	486.4	17.9	11.8
PB8 WC-47	11.37	440.7	14.6	7.9	67.0	494.7	32.5	11.7
PB8 WC-48	11.54	446.0	15.6	7.2	63.2	505.9	22.7	11.7
PB8 WC-49	11.81	454.4	16.2	7.0	62.4	521.5	22.2	11.7
PB8 WC-50	12.16	448.9	14.8	5.4	61.9	568.9	25.6	12.2
PB8 WC-51	12.35	425.0	14.8	5.8	65.1	487.1	18.7	13.1
PB8 WC-52	12.63	421.8	14.0	5.3	65.3	490.8	22.5	13.8
PB8 WC-53	13.12	463.6	15.4	5.9	67.2	528.7	16.2	15.1
PB8 WC-54	13.38	432.4	13.1	6.0	68.0	488.1	19.2	15.2
PB8 WC-55	13.59	442.2	14.9	6.2	70.8	499.1	22.6	16.1
PB8 WC-56	14.23	435.3	13.8	7.0	70.1	496.6	31.6	17.4
PB8 WC-57	14.55	430.3	13.5	7.0	69.3	487.2	28.6	16.7
PB8 WC-58	15.24	428.8	13.5	6.3	71.8	493.9	30.7	17.2
PB8 WC-59	15.33	426.5	13.1	6.5	72.8	484.1	31.4	18.8

Chemical analyses of interstitial and seawater samples from Prudhoe Bay, Alaska; in millequivalents per liter (continued).

SAMPLES	DEPTH	1	+	+	++	++	-	=	- 2
		Na	K	Ca	Mg	Cl	SO4	HCO3	
PB8 WC-60	15.90	443.5	13.6	6.9	73.9	496.8	38.1		
PB8 WC-61	16.13	453.6	13.4	7.4	77.4	514.3	44.5		
PB8 WC-62	16.68	697.3	22.3	12.6	118.2	556.7	40.3		
PB8 WC-63	16.99	473.0	14.8	13.7	91.9	518.4	50.7		
PB8 WC-64	17.61	443.6	14.1	10.1	84.1	510.0	36.7		
PB8 WC-65	18.40	718.7	22.7	15.8	130.5	571.0	42.7		
PB8 WC-66	18.86	448.4	13.7	11.4	87.6	511.2	43.8		
PB8 WC-67	19.30	445.9	13.5	11.7	86.2	511.4	44.4	7.7	
PB8 WC-68	20.44	445.2	13.8	17.5	99.6	524.9	47.5	5.4	
PB8 WC-69	26.55	479.2	16.2	29.1	100.5	542.3	48.7		
PH 25-02	2.30	528.2	16.4	25.9	111.9	589.7	73.2	4.4	
PH 25-05	2.68	547.1	17.2	25.6	115.6	623.9	71.3	5.1	
PH 27-01	1.95	665.9	19.3	33.0	144.0	765.7	81.5	3.8	
PH 27-03	2.17	642.3	17.2	31.4	147.9	745.2	66.2	5.1	
PH 27-05	2.37	754.6	23.5	38.7	178.3	898.7	48.8	4.9	
PB9 WC-1A	0.15	8.5	0.3	5.6	1.8	12.5	0.9	1.8	
PB9 WC-1B	0.15	7.1	0.2	6.7	1.8	11.7	1.6	2.0	
PB9 WC-2A	0.46	6.5	0.2	5.6	1.6	8.3	2.2	3.1	
PB9 WC-2B	0.46	1.8	0.2	3.2	0.7	1.4	4.0	3.2	
PB9 WC-2C	0.46	0.9	0.1	3.1	0.6	0.7	3.4	2.9	
PB9 WC-3A	0.76	0.9	0.1	3.8	0.6	1.4	3.0	2.9	
PB9 WC-3B	0.76	1.9	0.2	7.4	1.4	5.7	3.0	3.5	
PB9 WC-4A	1.07	6.6	0.3	13.0	2.8	17.6	2.4	3.4	
PB9 WC-4B	1.07	3.0	0.2	8.6	1.7	9.0	2.9	3.4	
PB9 WC-4C	1.07	4.7	0.2	5.2	1.2	5.5	3.3	3.4	
PB9 WC-5A	1.37	6.8	0.3	10.4	2.7	12.6	2.2	4.8	
PB9 WC-5B	1.37	7.0	0.3	12.0	3.0	14.7	2.9	4.4	
PB9 WC-6A	3.12	8.2	0.4	3.3	4.4	9.6	4.1	3.7	
PB9 WC-6B	3.12	7.7	0.5	2.4	3.5	8.9	3.3	2.6	
PB9 WC-7	3.73	16.0	0.7	4.3	6.9	19.4	5.4	3.8	
PB9 WC-8A	5.03	37.0	3.2	16.1	19.4	47.7	14.8	4.2	
PB9 WC-8B	5.03	34.3	3.2	14.6	17.7	45.4	14.7	4.2	
PB9 WC-9A	6.78	63.3	5.3	16.6	18.9	78.6			
PB9 WC-9B	6.78	63.0	3.7	18.9	25.6	78.3	5.2	2.5	
PB9 WC-11	11.05	135.0	6.0	13.6	26.6	161.7	5.3	3.5	
PB9 WC-12	13.26	94.9	6.3	12.1	19.9	115.7	3.8	2.8	
PB9 WC-13	14.10	162.9	6.6	24.2	34.9	194.1	2.7	3.1	
PB9 WC-14	16.31	145.4	8.0	17.8	24.1	173.6	4.4	2.3	
PB9 WC-15	17.14	165.0	7.9	15.2	20.1	196.4		3.0	
SW1 WS-1	1.83	455.3	11.2	20.8	103.2	529.9	40.0		
SW1 WS-2	3.05	456.0	11.2	20.6	104.2	523.3	44.1		
SW1 WS-3	4.27	450.2	11.0	20.3	103.0	526.1	50.1		
SW2 WS-1	1.83	458.3	11.4	20.7	104.8	528.0	42.2		
SW2 WS-2	3.66	455.7	11.6	20.9	103.5	526.1	58.5		
SW2 WS-3	5.18	463.2	10.6	20.7	103.4	526.1	50.3		
PB7 WS-1	0.30	473.9	11.5	22.0	107.3	539.3	49.4		
PB7 WS-2	3.05	467.5	11.5	21.0	105.9	534.6	53.5		
PB5 WS-1	1.62	537.8	13.6	24.6	123.2	621.0	61.2	2.3	
PB6 WS-1	1.83	747.3	19.4	35.7	175.4	911.2	82.7	3.4	
PB7 WS-3	1.95	475.6	11.8	22.2	108.8	551.8	51.4	2.0	
PB8 WS-1	2.00	453.9	11.4	20.9	105.2	527.3	44.7	1.9	
PB8 WS-2	4.50	452.2	11.5	21.1	103.0	523.7	46.9	2.0	
PB8 WS-3	7.00	449.7	11.3	20.9	103.0	525.8	44.9	2.1	

1
in meters

2
alkalinity is expressed as bicarbonate