



**US Army Corps  
of Engineers®**  
Engineer Research and  
Development Center

# Rapid Maximum-On-Ground (MOG) Enhancement Technologies

Report 1

Matting Systems for Contingency Helipads and C-130 Test Sections

Gary L. Anderton and Chad A. Gartrell

January 2005



# **Rapid Maximum-On-Ground (MOG) Enhancement Technologies**

## **Report 1 Matting Systems for Contingency Helipads and C-130 Test Sections**

Gary L. Anderton and Chad A. Gartrell

*Geotechnical and Structures Laboratory  
U.S. Army Engineer Research and Development Center  
3909 Halls Ferry Road  
Vicksburg, MS 39180-6199*

Report 1 of a series

Approved for public release; distribution is unlimited

**ABSTRACT:** This report describes field experiments and test section analyses conducted to evaluate commercially available matting systems for use in the rapid construction of contingency airfield taxiways and parking aprons. The main goal of this project is to increase the Maximum-On-Ground (MOG) rating of an austere airfield and thereby increase the aircraft throughput capacity of the airfield. Operation Brownout, conducted at Fort Campbell, Kentucky, was the beginning of the experiment in which four commercial matting systems (Mobi-Mat, DURA-BASE, SUPA-TRAC, and Multi-Purpose (MP) Mat) were evaluated for dust control on austere helipads and general constructibility issues. The conclusions from this field exercise resulted in the U.S. Army's purchase of the Mobi-Mat System for expedient contingency helipad construction. This demonstration also helped identify the matting systems that would be tested for MOG enhancement the following year. Mat test items were placed over varying soil sub-grade strengths and trafficked with a C-130 tire mounted onto a load cart to simulate fully loaded aircraft traffic. The products chosen were DURA-BASE, MP Mat, Rapid Mat (Folded Fiberglass Mat), Rolla Road Mark III, and SP-12. The results showed that the DURA-BASE system could provide the best support in all soil conditions, as expected; however, with its large logistical footprint, this system has limited deployment potential. The MP Mat system was chosen as the best alternative on the basis of strength, low logistical footprint, ease of assembly, and, similar to the DURA-BASE, durability and reusability.

**DISCLAIMER:** The contents of this report are not to be used for advertising, publication, or promotional purposes. Citation of trade names does not constitute an official endorsement or approval of the use of such commercial products. All product names and trademarks cited are the property of their respective owners. The findings of this report are not to be construed as an official Department of the Army position unless so designated by other authorized documents.

# Contents

---

Executive Summary .....	vi
Preface .....	vii
1—Introduction .....	1
Background .....	1
Purpose .....	2
Scope .....	2
2—Contingency Helipad Exercise .....	4
Background .....	4
Design Considerations .....	4
Construction .....	5
Mobi-Mat .....	6
DURA-BASE .....	7
SUPA-TRAC .....	7
Multi-Purpose Mat .....	8
Helicopter Tests .....	8
Mobi-Mat .....	8
DURA-BASE .....	9
SUPA-TRAC .....	9
Multi-Purpose Mat .....	9
Exercise Results .....	10
3—Rapid MOG Enhancement Test Section .....	11
Background .....	11
Design Considerations .....	11
DURA-BASE .....	14
Multi-Purpose Mat (5-Ply) .....	14
Rapid Mat (Folded Fiberglass Mat, FFM) .....	14
Rolla Road Mark III .....	15
SP-12 Mat .....	15
Construction .....	15
Instrumentation .....	18
Trafficking and Data Collection .....	18
Failure Criteria .....	19
4—Test Section Results .....	21
General Summary .....	21



Control.....	22
DURA-BASE .....	29
Multi-Purpose Mat .....	29
Rapid Mat (FFM) .....	29
Rolla Road Mark III .....	29
SP-12 Mat.....	30
5—Conclusions .....	31
Photos 1-38	
SF 298	

## List of Figures

---

Figure 1.	High-strength MOG test section (clay gravel = 40 to 50 CBR) .....	12
Figure 2.	Medium-strength MOG test section (clay gravel removed) (8 to 10 CBR) .....	12
Figure 3.	Low-strength MOG test section (reconstituted CH clay) (3 to 5 CBR).....	12
Figure 4.	Rut depth for high-strength subgrade (40 to 50 CBR) test items ...	19
Figure 5.	Rut depth for medium-strength subgrade (8 to 10 CBR) test items.....	20
Figure 6.	Rut depth for low-strength subgrade (3 to 5 CBR) test items .....	20
Figure 7.	Hangar 4 Pavement Testing Facility test section layout.....	22
Figure 8.	Permanent surface deformation cross section for control (no mat) on high-strength subgrade (40 to 50 CBR).....	23
Figure 9.	Permanent surface deformation cross section for DURA-BASE on high-strength subgrade (40 to 50 CBR).....	23
Figure 10.	Permanent surface deformation cross section for MP Mat on high-strength subgrade (40 to 50 CBR).....	24
Figure 11.	Permanent surface deformation cross section for Rapid Mat on high-strength subgrade (40 to 50 CBR).....	24
Figure 12.	Permanent surface deformation cross section for Rolla Road on high-strength subgrade (40 to 50 CBR).....	25
Figure 13.	Permanent surface deformation cross section for SP-12 mat on high-strength soil (40 to 50 CBR) .....	25
Figure 14.	Permanent surface deformation cross section for control (no mat) on medium-strength soil (8 to 10 CBR) .....	26

Figure 15.	Permanent surface deformation cross section for DURA-BASE on medium-strength soil (8 to 10 CBR).....	26
Figure 16.	Permanent surface deformation cross section for MP Mat on medium-strength soil (8 to 10 CBR).....	27
Figure 17.	Permanent surface deformation cross section for control (no mat) on low-strength soil (3 to 5 CBR) .....	27
Figure 18.	Permanent surface deformation cross section for DURA-BASE on low-strength soil (3 to 5 CBR).....	28
Figure 19.	Permanent surface deformation cross section for MP Mat on low-strength soil (3 to 5 CBR).....	28

## List of Tables

---

Table 1	Comparative Construction and Cost Data for Contingency Helipad Mat Systems .....	6
Table 2	Clay Gravel Properties (Gravelly Clayey Sand) (SP-SC) .....	13
Table 3	High-Plasticity Clay Properties .....	13
Table 4	Selected Pre- and Post-Traffic Soil Density Values (Dry Densities, pcf) .....	16
Table 5	Selected Pre- and Post-Traffic Soil Strength Values .....	16

# Executive Summary

---

This report describes an investigation designed to evaluate different commercial matting systems for use in the rapid construction of taxiways and parking aprons on austere C-130 transport aircraft airfields. This technology will give U.S. military forces the ability to increase the aircraft throughput capacity of a desirable austere airfield and thereby deploy the required military components more rapidly.

The investigation included two parts: a demonstration exercise at Fort Campbell, KY, in April 2002 and controlled test section experiments at the U.S. Army Engineer Research and Development Center (ERDC), Vicksburg, MS, during the period March to October 2003. The Fort Campbell demonstration had the objective of evaluating four commercial matting systems and determining which was most suited for dust control on unsurfaced or semiprepared helipads during takeoff and landing operations. The controlled test sections constructed at ERDC were used to evaluate matting systems chosen based on experience gained from the Fort Campbell exercise to be used for the expedient construction of taxiways and parking aprons at austere airfields. The matting systems were evaluated over three different soil strength subgrades with traffic provided by a single, fully loaded, C-130 aircraft tire mounted to a load cart. The performance of the matting systems was based on deflection measurements, permanent deformation, and observed physical integrity of the mats during trafficking.

A summary of each matting system evaluated, both at Fort Campbell and ERDC, is included in this report, along with summaries of each system's performance and final recommendations for both dust mitigation on austere, semiprepared helipads and rapid MOG expansion on austere, semiprepared airfields.

# Preface

---

The tests and results described herein cover the first 2 years of a planned 4-year research effort entitled “Rapid MOG Enhancement Technologies.” The term MOG used here refers to the maximum-on-ground rating, or the number of aircraft that can remain on the ground at any one time at a given airfield. Light-weight matting systems are seen as a viable pavement-surfacing alternative, particularly for military operations in remote locations and when construction expediency is important.

The Rapid MOG Enhancement Technologies project is a part of the Joint Rapid Airfield Construction (JRAC) program. The JRAC program is a comprehensive, 6-year, demonstration-based research and development program being executed by the U.S. Army Engineer Research and Development Center (ERDC) during fiscal years 2002 through 2007. The JRAC program is sponsored by Headquarters, U.S. Army Corps of Engineers, in Washington, DC.

This publication was prepared by personnel of ERDC Geotechnical and Structures Laboratory (GSL), Vicksburg, MS. The findings presented in this report are based upon evaluations of a contingency helipad exercise conducted at Fort Campbell, KY, in April 2002 and a series of controlled test section experiments at the ERDC-Vicksburg site conducted during 2003. The principal investigators for this study were Dr. Gary L. Anderton and Mr. Chad A. Gartrell, Airfields and Pavements Branch (APB), GSL. Other ERDC-GSL-APB personnel who assisted at the Fort Campbell exercise include Mr. Timothy McCaffrey, Dr. James E. Shoenberger (deceased), and Mr. Carroll J. Smith, retired. ERDC personnel who assisted with the ERDC test sections include Messrs. Harold T. Carr (Information Technology Laboratory), Louis W. Mason (GSL), and Dennis J. Beausoliel (Directorate of Public Works).

Dr. Anderton and Mr. Gartrell prepared this report under the supervision of Mr. Don R. Alexander, Chief, APB, and Dr. David W. Pittman, Director, GSL. At the time of publication of this report, Dr. James R. Houston was Director of ERDC, and COL James R. Rowan, EN, was Commander and Executive Director.

Recommended changes for improving this publication in content and/or format should be submitted on DA Form 2028 (Recommended Changes to Publications and Blank Forms) and forwarded to Headquarters, U.S. Army Corps of Engineers, ATTN: CECW-EWS, Kingman Building, Room 321, 7701 Telegraph Road, Alexandria, VA 22315.

# 1 Introduction

---

## Background

The U.S. Army Engineer Research and Development Center (ERDC) began a 6-year comprehensive research, development, and demonstration program in 2002 entitled the Joint Rapid Airfield Construction (JRAC) program. The JRAC program is focused on providing engineering tools and systems that will dramatically increase the U.S. military's contingency airfield upgrade and construction capabilities. These revolutionary new capabilities will allow the warfighter to meet Future Force deployment requirements (first brigade in 96 hr, first division in 120 hr, and five divisions in 30 days). These objectives will be met through advancements in site selection technologies, enhanced construction methodologies, and new materials and techniques for rapid soil stabilization. All of these technologies, used either separately or as part of an integrated system, will focus on reducing the engineering timeline, reducing the manpower requirements, reducing the logistical footprint, and increasing system reliability. The current design aircraft for the JRAC program are the C-130 and C-17. JRAC "spin-off" technologies are certain to have a positive impact on other military aircraft facilities, such as helipads, vertical takeoff and landing aircraft platforms, and short field assault landing zones for unmanned air vehicles and other future aircraft. The JRAC Program schedule calls for major demonstrations of JRAC technologies in fiscal year 2004 and fiscal year 2007, the 2004 demonstration having been completed at Fort Bragg, NC, and currently under final evaluation as of this report.

One of over 30 projects within the JRAC program is entitled "Rapid MOG Enhancement Technologies." The term MOG refers to the maximum-on-ground rating, or the number of aircraft that can remain on the ground at any one time at a given airfield. An airfield's MOG rating is vitally important in a military war planning and deployment scenario, as the MOG rating controls the throughput capacity of the airfield. Rapid expansion of existing airfield parking areas or construction of new aircraft parking space is the focus of the Rapid MOG Enhancement Technologies project. Since the "rapid" units of time in this case are measured in hours and days, it is unreasonable to consider traditional asphalt or portland cement concrete pavement surfacings. Thus, lightweight matting systems are seen as a viable pavement-surfacing alternative, particularly for military operations in remote locations and when construction expediency is of utmost importance. Numerous lightweight, modular pavement matting systems are currently available, but none has any documented performance history under heavy-cargo

aircraft loads. Much has been learned in recent years about these types of matting systems when used in military applications for ground vehicles,<sup>1,2,3</sup> and this study is seen as an extension of this previous work into the airfield arena.

## Purpose

The purpose of this report is to present the results of a study into the capacity of several matting systems to effectively mitigate dust at military helicopter landing zones during arrival and departure and sustain C-130 transport aircraft loads. Several important considerations are examined in this study besides the load-carrying capacity of the mats: durability, weight, ease of construction, and versatility. This report documents the experiments conducted under and supports the continuation of the JRAC program's Rapid MOG Enhancement Technologies project. In addition, this report also gives the basis for the matting systems that were evaluated in the JRAC program's first major demonstration project during the summer of 2004. Performance results from the 2004 JRAC demonstration and continued test section evaluations during the final 2 years of this study will likely refine the conclusions reached and described in this report.

## Scope

The first phase of the research study described in this report consisted of two test section evaluations. The first experiment took place at Fort Campbell, KY, where the U.S. Army's 326th Engineer Battalion (EN BN) conducted a field exercise to construct contingency helipads using four matting systems. The exercise included the use of troop labor under simulated expedient construction conditions and limited landing and takeoff operations from both a CH-47 Chinook and a UH-60 Blackhawk helicopter. The focus of this exercise was to determine the most logistically suitable matting system that could effectively reduce the excessive dust generation phenomenon known as "brownout" during helicopter operations on unsurfaced or semiprepared contingency helipads.

The second experiment conducted during the first 2 years of this 4-year study was a series of controlled test sections constructed at the ERDC-Vicksburg Hangar 4 Pavement Test Facility. Five matting systems were initially evaluated in this program, which included three varying subgrade support layers and traffic applied by a single-wheel C-130 load cart. Mat performance was gauged by

---

<sup>1</sup> Webster, S. L., and Tingle, J. S. (1998). "Expedient road construction over sands using lightweight mats," Technical Report GL-98-10, U.S. Army Engineer Waterways Experiment Station, Vicksburg, MS.

<sup>2</sup> Santoni, R. L., Smith, C. J., Tingle, J. S., and Webster, S. L. (2001). "Expedient road construction over soft soils," Technical Report ERDC/GSL TR-01-7, U.S. Army Engineer Research and Development Center, Vicksburg, MS.

<sup>3</sup> Santoni, R. L. (2003). "Enhanced coastal trafficability: Road construction over sandy soils," Technical Report ERDC/GSL TR-03-7, U.S. Army Engineer Research and Development Center, Vicksburg, MS.

deflection measurements, permanent deformation, and observed physical integrity of the mats themselves during trafficking.

The final evaluation for the first phase of this project included the construction and subsequent aircraft traffic evaluations of one of the mat systems at the 2004 demonstration project. There are also plans for continued test section evaluations at the ERDC-Vicksburg facilities, to include combinations of mat systems and foundational improvements such as soil stabilizers and geotextiles, as well as the increased load demands of the C-17 aircraft. The ultimate goal of this study is to provide design and performance guidance for systems and materials used to rapidly increase the MOG capacity of a contingency airfield.

# 2 Contingency Helipad Exercise

---

## Background

Following Operation Desert Storm, the 101st Air Assault Division (AASLT) incurred tremendous expense replacing both helicopter main rotor blades and engines due to foreign object debris (FOD) caused by the rotor-wash of helicopters landing and taking off. The combination of poor environmental conditions and lack of a pre-existing infrastructure was noted to reduce the effectiveness and readiness of its helicopters. Also, helicopter operations on unsurfaced helicopter landing zones (HLZ) are known to create blinding dust signatures commonly referred to as brownout conditions (Photo 1). The dust generated in these conditions has caused crashes and fatalities. For these reasons, the 326th EN BN was tasked to procure a nonpermanent landing platform to reduce the effects of FOD and brownout conditions on helicopters.

Helipad matting solutions that currently exist within the Army's inventory consist of M-19 and AM-2. The size and weight of these mats make them undesirable for use as a solution for helipads in a forward operating base (FOB). Constraints based on availability of lift assets and material handling equipment (MHE) placed on a light force due to the weight and size of the current matting systems make the need for replacement matting apparent. The replacement matting must have a small logistical footprint, be installed quickly and easily, need minimal special installation tools and MHE, reduce FOD in an FOB, be durable, and be easily reconfigured and reused.

## Design Considerations

A wide variety of matting was initially evaluated to obtain the basic characteristics of each system and to determine which would meet the needs of the 101st AASLT. Evaluation criteria were established and cross-referenced with the design characteristics of each available mat. The following desired characteristics were established as ideal:

- a. Lightweight and easily transported by C-130, C-17, and CH-47 airframes.



- b.* Sufficiently durable to sustain direct helicopter loads.
- c.* Extended life and of a reusable nature.
- d.* Installed manually with no MHE in order to minimize airframes for transport.
- e.* Easily installed with few or no special tools, requiring little additional soldier training.
- f.* Commercial off-the-shelf availability.
- g.* Able to be rapidly employed for use.

The manufacturers of the mats that most closely met the ideal characteristics were contacted and invited to demonstrate the effectiveness and characteristics of their mat to the 326th EN BN. The testing was conducted at Fort Campbell during April 1-5, 2002. The mats were shipped the week prior to the testing and the contractors arrived on April 1-2 to oversee the construction and use of their matting. The following systems were participants in the testing:

- a.* Deschamps Mobi-Mat®.
- b.* DURA-BASE® Composite Mat System.
- c.* SUPA-TRAC®.
- d.* Multi-Purpose Fiberglass Matting.

Two potential sites were identified: Golden Eagle Forward Landing Strip (FLS) and Aardvark LZ (Landing Zone). Both landing strips are unsurfaced. Golden Eagle FLS is an active runway. Because of the requirement for Golden Eagle FLS to be undisturbed, Aardvark LZ was chosen as the testing site. To best replicate the effects that would be seen in a desert environment, Aardvark LZ was compacted and scarified. Although it had rained the night prior to testing, the ground was sufficiently dry to produce limited dust and flying debris.

## **Construction**

The mat test sections were constructed by the 887th Light Equipment (LE) Company in coordination with the 326th EN BN (Photo 2). This company was divided into four teams of 8 to 11 soldiers each. Each team was randomly assigned responsibility to construct a 15.25-m (50-ft) by 30.5-m (100-ft) helipad on the Aardvark LZ runway using one of the four matting systems. Each team was given limited onsite training from the matting system manufacturers just before and at the beginning of the test section assembly phase. All matting systems were deemed simple enough to assemble with limited training. Each matting system had been unloaded and placed next to the test areas on the day previous to the construction day. The troops were switched between the different matting systems one time in the afternoon in order to expose the troops to at least two

systems. Some systems were placed, partially disassembled, and then reassembled for practice. Construction data captured during this exercise are shown, along with cost data, in Table 1.

<b>Table 1 Comparative Construction and Cost Data for Contingency Helipad Mat Systems</b>							
<b>Mat System</b>	<b>Quantity of Materials to Construct HLZ</b>	<b>Required Equipment</b>	<b>Projected Installation Rate<sup>1</sup></b>	<b>Unit Weight</b>	<b>Unit Volume</b>	<b>Unit Cost</b>	<b>Total Cost/Pad</b>
Mobi-Mat	12 panels 4.2 m x 10 m (13.9 ft x 33 ft)	Forklift, sledge hammers, flatbed	500 ft <sup>2</sup> /man-hr	1.9 kg/m <sup>2</sup> (0.38 lb/sq ft)	1.84 m <sup>3</sup> (65 cu ft)	\$5,887.50	\$70,650.00
DURA-BASE	50 panels 2.4 m x 4.3 m (8 ft x 14 ft)	Forklift/crane	300 ft <sup>2</sup> /man-hr	42.6 kg/m <sup>2</sup> (9.4 lb/sq ft)	1.13 m <sup>3</sup> 40 cu ft	\$1,600.00	\$80,000.00
SUPA-TRAC	2,450 panels 914 mm x 229 mm (36 in. x 9 in.)	Forklift	600 ft <sup>2</sup> /man-hr	7.5 kg/m <sup>2</sup> (1.7 lb/sq ft)	7646 cm <sup>3</sup> (0.27 cu ft)	\$20.00	\$49,000.00
MP Fiberglass Reinforced Matting	125 panels 2.0 m x 2.0 m (6.67 ft x 6.67 ft)	Forklift	300 ft <sup>2</sup> /man-hr	11.8 kg/m <sup>2</sup> (2.6 lb/sq ft)	0.073 m <sup>3</sup> (2.6 cu ft)	\$320.00	\$40,000.00

<sup>1</sup> Installation assumes a typical five-man crew.

## **Mobi-Mat**

Mobi-Mat arrived by truck at the testing site in large wooden crates that contained six rolls of mat in each crate (Photo 3). The crates can be transported using a C-130 or C-17 airframe and can be easily reconfigured as a slingload for transport by a CH-47. The complete weight of one crate was 953 kg (2,100 lb), easily moved by the smallest forklift in a light equipment inventory. Mobi-Mat is a woven polyester fabric that was delivered in rolls 4.2 m (13.8 ft) wide and 10 m (33.0 ft) in length. A single roll weighed 80 kg (176 lb) and could be moved by two people. Two soldiers unloaded and transported the Mobi-Mat to the desired location, and 12 sections satisfied the minimal contingency helipad size of 15.25 m (50 ft) by 30.5 m (100 ft). The matting system was assembled by rolling out (Photo 4) and hand-stretching individual panels (Photo 5), connecting individual panels in the middle with interlocking straps, and then anchoring the outside edges with 0.60-m- (2-ft-)long metal spikes. The interior corners of successive rolls were anchored together by placing the pins in overlapping holes. The metal spikes were hammered through the large metal eyelets at the edge of the mat and into the ground using sledgehammers (Photo 6). No additional tools or MHE were needed. Photo 7 shows a view of the completed Mobi-Mat test section.

Mobi-Mat was the simplest system to construct. The soldiers quickly grasped how to assemble the matting system, and site preparation was not needed. The mat was easily locked together with the straps provided, although it was quite labor intensive for the soldiers to install the metal anchoring spikes using sledgehammers. It was noted that the spikes could be substituted with military U-shaped pickets, utilizing the interlocking straps to tie the mat down to the

upper eyelet of the picket. Soldiers could then use picket pounders or hydraulic picket pounders to assemble the mat, greatly increasing the speed of installation.

## **DURA-BASE**

DURA-BASE is a high-density polyethylene (HDPE) plastic mat, about 2.4 m (8 ft) by 4.25 m (14 ft) in surface area and 108 mm (4.25 in.) thick and weighing about 476 kg (1,050 lb) per panel. The panels are connected by the alignment of holes on the overlap and underlap edges of the mats. Each mat is composed of two identical sheets that are bolted together and heat welded with a designed offset to achieve the overlap and underlap edges. The individual panels are held together with connector pins made of metal enclosed within plastic. These connectors are turned one quarter turn to lock them in place and connect individual panels.

Construction of the DURA-BASE helipad was done quickly and simply, but each panel had to be placed using a large forklift and an experienced operator (Photo 8). As the forklift operator placed each panel, a simple bar tool was used to align the pinholes (Photo 9). The pins were dropped into place and the same bar tool was used to lock the pin (Photo 10), providing a solid connection between adjacent panels. The majority of the panels were held together with two connector pins per side. The completed helipad was not anchored to the soil surface because its weight logically prevented any movement by the helicopters. In less than 1 hour, the soldiers had constructed the required 15.25-m (50-ft) by 30.5-m (100-ft) helipad.

## **SUPA-TRAC**

The SUPA-TRAC matting system is made from a nonslip polypropylene plastic material that is produced in pieces 229 mm (9 in.) by 914 mm (36 in.) and 35.5 mm (1.4 in.) thick. This matting material is relatively light, at 7.48 kg/m<sup>2</sup> (1.65 lb/ft<sup>2</sup>), and was easily carried by one soldier when delivered in sections with five pieces already assembled (Photo 11). These panels snap together with the heel of a boot or small hammer (Photo 12). Each panel has a number of connections that are held together with plastic clips. The plastic clips must be tapped in with a rubber mallet (Photo 13), and this process turned out to be the most time-consuming portion of assembly. Metal pins, about 610 mm (24 in.) long, were used to hold the mat edges down (Photo 14). No special equipment or MHE was needed for assembly.

The SUPA-TRAC system was constructed in a short amount of time. The entire system went together smoothly once the soldiers worked out the assembly process. Several of the plastic connecting clips were broken during installation and several of the panels were cracked when soldiers missed the edge spikes with the sledgehammers and hit the mat. This system has ramp pads along the edges with predrilled holes to put the metal anchoring spikes through. This design feature makes it impossible to ground the mat using other means.

## Multi-Purpose Mat

The Multi-Purpose (MP) mat is a fiberglass panel approximately 9.5 mm (3/8 in.) thick and 2.0 m by 2.0 m (6 ft-8 in. by 6 ft-8 in.) in overall area, producing a usable surface of 3.34 m<sup>2</sup> (36 ft<sup>2</sup>) when connected. These panels weigh about 52 kg (115 lb) each and can be easily handled by two people. The panels are connected by six locking aluminum pins. Each panel has underlap edges on two sides and corresponding overlap edges on the other two sides. When required, an MP matting system can be held in place through the use of cabled duckbill anchors (Photo 15) driven into the soil and connected to the outside edges of the panels.

The MP Mat helipad was easily constructed with two troops carrying and placing each panel, while other troops aligned the panels with a simple alignment tool (Photo 16). Next, one soldier placed connector pins into the pinholes while another soldier completed the assembly process by locking the connector pins with a pneumatic drill (Photo 17). A number of connector pins were also locked in place using a simple socket wrench (Photo 18). A gasoline engine-powered jackhammer was predominantly used to drive the duckbill anchors into the sandy-clay soil (Photo 19). Several anchors were also successfully placed with a hand-operated post-hole driver.

## Helicopter Tests

Once assembled, each matting system was tested under both static and dynamic loads of a CH-47 and UH-60 helicopter. The intent of this test was to determine the extent that each matting system would reduce ground dust from prop wash, or brownout conditions, and to determine if the matting system could effectively carry the helicopter loads in both a static parking state and a slow-rolling dynamic state. Ground observers and helicopter pilots made visual determinations during and after helicopter landing and taxiing operations. The actual extent of the traffic tests included three CH-47 Chinook landings and takeoffs along with one rolling pass of this helicopter and one landing with a 360-deg turn from the UH-60 Blackhawk helicopter. Photo 20 shows an aerial view of the Aardvark LZ helipad test sections prior to testing. These limited tests were insufficient to adequately evaluate the load-bearing capacity of each mat system, but did provide a subjective basis for evaluating each system's ability to mitigate dust and prevent brownout conditions.

## Mobi-Mat

The Mobi-Mat system performed well under all traffic loads and did not show any signs of deformation from helicopter rotor wash loads. When placed under dynamic loads, the mat tended to bunch or creep in front of the rolling wheels of the aircraft. While a concern at first, this bunching had no effect on the load-bearing capacity or structural integrity of the mat. The ends of the mat tended to curl up into the shape of the rolled mat, but it was noted that the Mobi-Mat panels could be manufactured with reinforced edges to reduce this. The

interlocking tie straps worked well and did not reveal any signs of stress or failure. Dust generation was significantly reduced once the aircraft hovered directly over the helipad and while resting on the helipad with rotors still turning. The helicopter pilots commented that the Mobi-Mat helipad had a spongy feel underneath the aircraft, which is logical because of its relatively high level of flexibility. Photo 21 shows a CH-47 landing on the Mobi-Mat helipad. On account of Mobi-Mat's high level of flexibility, it is unlikely that the mat will provide significant improvement in load-bearing capacity beyond that provided by subgrade support when used on the surface. The primary benefit in this evaluation was as a FOD cover for dust mitigation. The porous nature of the mat may also be a concern should the subgrade become wet or soft.

## **DURA-BASE**

DURA-BASE was the only matting system tested that did not require an anchoring system because of its relatively heavy dead weight. Not surprisingly, this system did not show any adverse effects from the helicopter rotor wash. The textured panels provided outstanding traction and no deflection under the load of either helicopter was perceived. Excessive dust generation was eliminated once the aircraft hovered directly over the helipad. Photo 22 shows a UH-60 Blackhawk operating on the DURA-BASE helipad. DURA-BASE is expected to provide excellent load-bearing capacity improvements based on its strong structural configuration. However, detailed structural evaluation of the mat was not possible because of the limited traffic applied.

## **SUPA-TRAC**

The SUPA-TRAC system performed reasonably well during the helicopter tests. Excess dust and FOD were reduced while the aircraft were hovering directly above or operating on the matting system itself (Photo 23). Inspection of the mats after the limited helicopter operations showed that the plastic panels did sustain some damage (Photo 24). It was not determined if the limited damage occurred as the result of static or dynamic loads. Also, one edge panel loosened during testing because of rotor wash, but no significant deflection or upheaval resulted from this failure. The SUPA-TRAC system is expected to provide improved load-bearing support, but system component durability is questioned because of the damage noted after the very limited traffic and installation.

## **Multi-Purpose Mat**

The MP fiberglass reinforced mats performed extremely well under all helicopter tests by significantly reducing dust while providing a firm helipad surfacing for taxiing and static loads. Some minor deflections were noted when the helicopters touched down and rolled, but no damage or dangerous undulations were observed. The helicopter tests suggested that only corner connector pins are actually needed for helicopter loads. Also, it was agreed that the duckbill anchoring system was excessive, and that a simple edge staking system should be more than adequate to resist uplift or other movement from rotor wash. Photo 25

shows the dust generated from an approaching UH-60 helicopter being diffused as the aircraft hovers over the MP Mat helipad.

## Exercise Results

The testing conducted allowed for each mat system to be compared against the minimum requirements and each other. Each of the four systems was able to successfully withstand the three CH-47 landings and takeoffs along with one rolling pass of this helicopter and one landing with a 360-deg turn of the UH-60 helicopter. The only notable damage was that described during installation and trafficking. Logistical considerations would be the differentiating factors in determining the most suitable matting systems for contingency helipads.

Only the DURA-BASE system required MHE to assemble. Unless MHE is available to offload and maneuver the mats, this system cannot be emplaced. The weight of the matting limits the amount that could be brought in by airframe or as a secondary load. For these reasons alone, the DURA-BASE system should not be considered for expedient contingency helipads. The SUPA-TRAC system showed signs of wear under limited dynamic and static loads of the helicopters, and the mats do not allow for the helicopter's mooring system to be emplaced without modification. For these reasons, the SUPA-TRAC system was not given further consideration as an expedient contingency helipad system.

Both the Mobi-Mat and the MP Mat systems met all requirements set forth in this exercise. The Mobi-Mat is easily configured for transport and produces the smallest logistical footprint. The soldiers installing the systems preferred the ease and lighter weight of the Mobi-Mat system to the MP Mat system. The MP Mat system was also deemed to be logistically friendly with its relative light weight and simple assembly requirements. MP Mats should do a better job of bridging over soft soil conditions when compared with the Mobi-Mat system and, as the name "multi-purpose" implies, MP Mats should be suited for many more application areas within a military theater of operations.

Logistical and cost data were gathered for each of the four matting systems evaluated during this field exercise and are summarized in Table 1. The 326th Engineer Battalion used these data along with the observations from the field exercise to formulate their recommendation that the 101st Airborne Division procure the Mobi-Mat system for use as contingency helipads. The Army acknowledged that all of the matting systems evaluated showed promise for several military applications.

# 3 Rapid MOG Enhancement Test Section

---

## Background

The Rapid MOG Enhancement Technologies project of the JRAC program was designed to evaluate available matting systems for use in the expansion or addition of taxiways and parking aprons at austere, forward-located airfields. The matting systems chosen were tested on soil subgrade strengths with California Bearing Ratio (CBR) values ranging from a low of 3 to 5 to a high of 40 to 50. Aspects such as mat weight, ease of assembly, durability, strength, and logistical footprint were all examined during these test section analyses.

The trafficking of test sections occurred between March and October 2003. All testing was performed by ERDC personnel at the Hangar 4 Pavement Test Facility in Vicksburg, MS. All test section construction and trafficking was performed by ERDC personnel. Materials for the test section included locally available high-plasticity (CH) “buckshot” clay for the subgrade, clay gravel (GC) from a local supplier used as a base, and various mat systems provided by product vendors.

## Design Considerations

The test section was constructed in layers to allow for quick transition from one test scenario to another by simply stripping off one layer to expose the next for testing. The section was built in two layers using clay gravel as the upper or surface material and high-plasticity clay as the subgrade material. The high-plasticity clay was chosen for its relative ease in moisture content control, which allows for the production of a uniform-strength material, as well as its onsite availability. The two-layer system allowed for three modes of testing with the same section. The test bed constructed was generally 6 m (20 ft) wide and 18 m (60 ft) long. This size was chosen to accommodate a matting test item of approximately 5.5 m (18 ft) wide by 15 m (50 ft) long. (The actual mat system size varied depending on the system tested.)

The clay gravel allowed mat testing on a subgrade with a CBR value of 40 to 50 (Figure 1). Previous experience with in situ soils indicated this to be a relatively high soil strength value for typical contingency airfield locations. The

second test scenario, with the clay gravel removed and the CH clay exposed, provided a CBR value of 8 to 10 for the testing surface (Figure 2). The final test scenario was to reconstitute the CH clay to a depth of 60.96 cm (24 in.) with added moisture to obtain a CBR of 3 to 5 (Figure 3). This low CBR value is the minimum strength deemed acceptable for a contingency airfield location. Baseline properties for the clay gravel and the high-plasticity clay are presented in Tables 2 and 3.

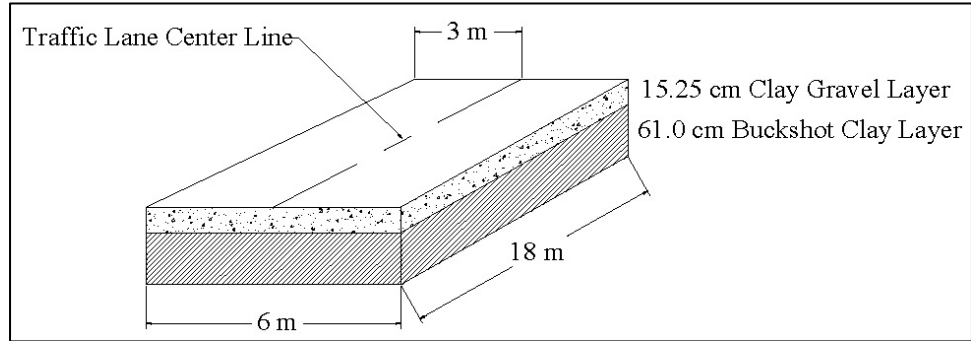

Figure 1. High-strength MOG test section (clay gravel = 40 to 50 CBR)

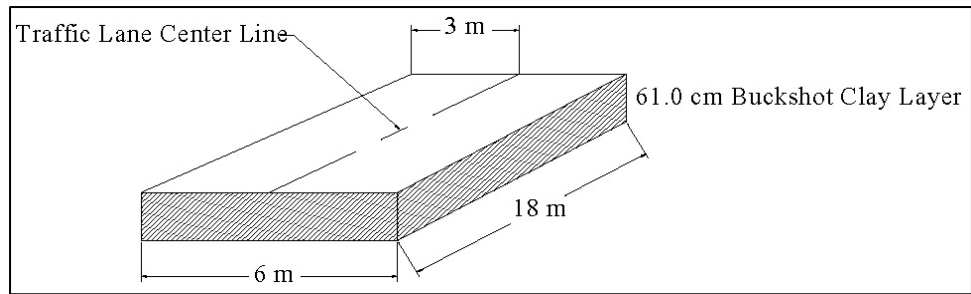

Figure 2. Medium-strength MOG test section (clay gravel removed) (8 to 10 CBR)

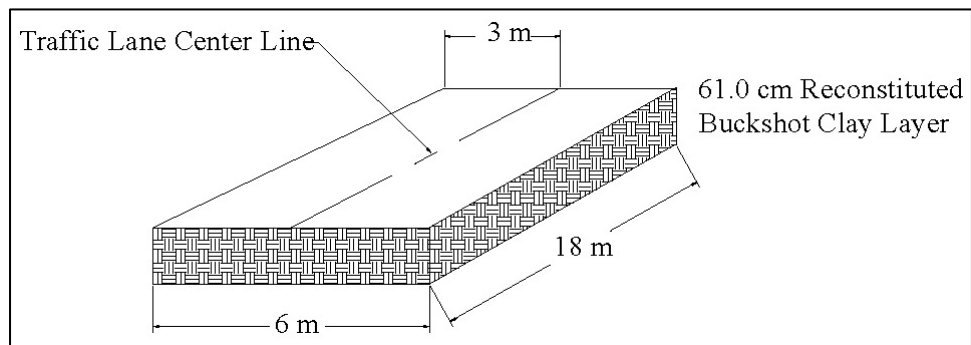
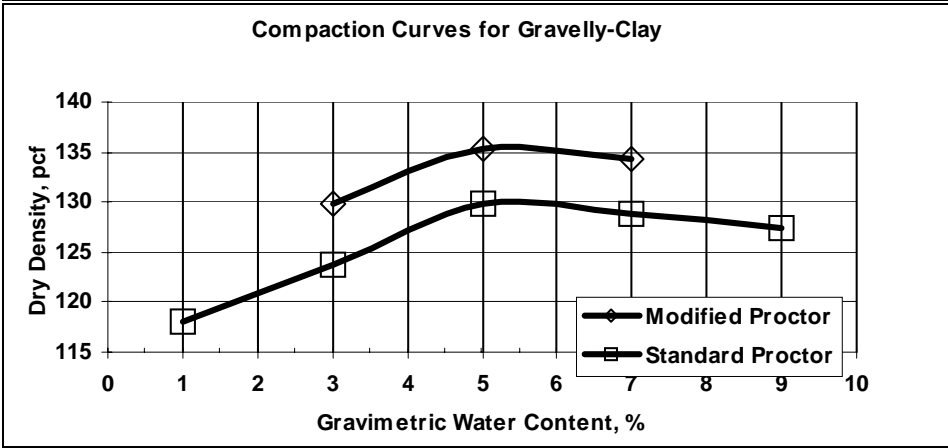

Figure 3. Low-strength MOG test section (reconstituted CH clay) (3 to 5 CBR)



**Table 2  
Clay Gravel Properties (Gravelly Clayey Sand) (SP-SC)**

Atterberg Limits	Gradation	Specific Gravity of Each Percentage
Liquid Limit (LL) = 27	Percent Gravel = 41.9	2.498
Plastic Limit (PL) = 9	Percent Sand = 42.6	2.66
Plasticity Index = 18	Percent Fines = 15.4	2.72



**Table 3  
High-Plasticity Clay Properties**

Atterberg Limits	Other
Liquid Limit (LL) = 76	Specific Gravity = 2.74
Plastic Limit (PL) = 24	Percent Clay (<0.005 mm) = 45.4
Plasticity Index = 52	

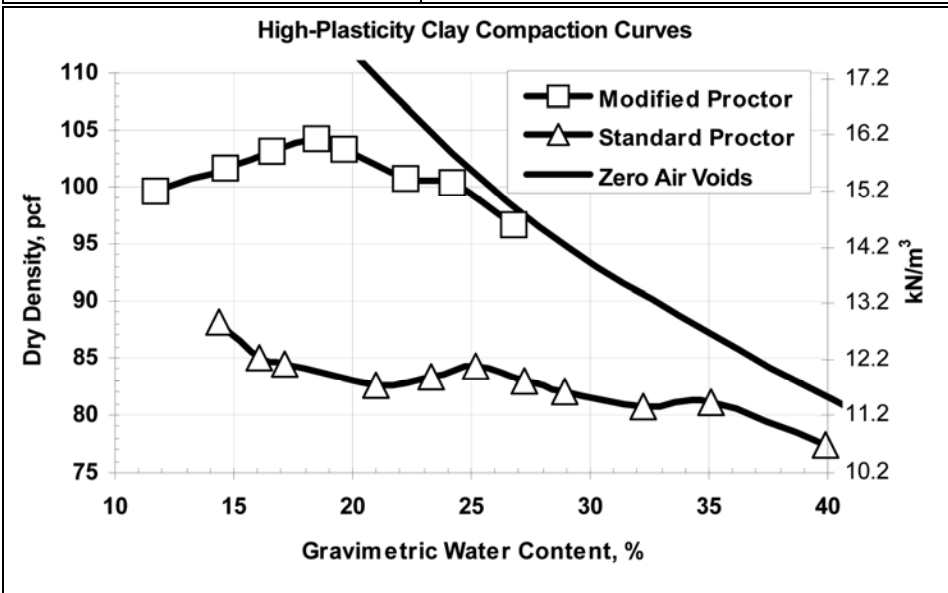

The mats chosen for testing were commercially available products that were considered reasonable choices for the type of service required. It was understood

that not all of these products would pass the first round of tests (high-strength subgrade support), and it was estimated that perhaps two or three of the products would survive until the end (low-strength subgrade support). Listed below are the various test items evaluated during this project:

- a. Unsurfaced control.
- b. DURA-BASE®.
- c. Multi-Purpose (MP) Mat (5-ply).
- d. Rapid Mat Folded Fiberglass Mat (FFM).
- e. Rolla Road Mark III®.
- f. SP-12 Mat.

## **DURA-BASE**

This matting system was originally designed and manufactured as a temporary load-bearing work platform system for use on low- and medium-strength soils by the oil-drilling industry. These mats have been found to be durable for the application of heavy truck traffic over soft, low-strength soils. The primary applications would be taxiways and parking aprons for contingency airfields, extensions or temporary additions to existing airfields, temporary helipads, and equipment storage pads. A material description of DURA-BASE is given in the Chapter 2 of this report. Photo 26 shows the installation of DURA-BASE on the test section.

## **Multi-Purpose Mat (5-Ply)**

This matting system was originally developed for expedient road construction over sandy soils. MP Mats, like the DURA-BASE Mats, have been found to be durable for application of heavy truck traffic over loose, sandy soils. They can also be used in the same applications listed for the DURA-BASE. A material description of MP Mat is given in Chapter 2 of this report. Photo 27 shows the assembly of MP Mat on the test section.

## **Rapid Mat (Folded Fiberglass Mat, FFM)**

This mat was originally developed as an inexpensive and easily deployed FOD cover for a newly repaired bomb crater on an airfield. The mats were designed to provide a protective cover to prevent the generation of FOD, which is extremely damaging to aircraft, from these newly repaired sites. The mats are red-brown in color and are made up of nine individual panels joined together with flexible fiberglass “strip-hinges.” Each of the nine panels is approximately 1.8 m (6 ft) wide and 9.1 m (30 ft) long, providing a total mat system area of 16.5 m (54 ft) by 9.1 m (30 ft). The mat is excessively heavy and requires at least

one forklift, and preferably two, to deploy and place the matting. The mat is extremely flexible and conforms to major changes in contour along the surface over which it is deployed. Photo 28 shows the deployment of Rapid Mat on the test section.

### **Rolla Road Mark III**

Rolla Road is another plastic mat product of the oil-drilling industry. This product was developed for ingress and egress of light- to medium-duty wheeled vehicles and equipment to drilling, exploration, and construction sites. The mat is green in color and is shipped as a roll, in this case approximately 15.25 m (50 ft) in length and 2.4 m (8 ft) in width. The mat weighs 38 to 45 kg/lineal meter (25 to 30 lb/lineal foot). This mat conforms to the ground very well because of its many joints and its rolled nature. Photo 29 shows the unrolling of the Rolla Road on the test section.

### **SP-12 Mat**

SP-12 is a mat developed by Soloco, LLC, the manufacturer of DURA-BASE, initially for application in the oil-drilling industry. It has gained some use and popularity as rapidly deployable foot-traffic flooring for tents and temporary shelters in both civilian and military applications. The SP-12 is considered an experimental mat and, at the time of this writing, was still in the developmental phases of design and manufacture. Photo 30 shows the typical installation of SP-12 Mat. The mat is approximately 0.91 m by 0.91 m (3 ft by 3 ft) with an effective area of about 0.83 m<sup>2</sup> (9 ft<sup>2</sup>). Similar in color to the DURA-BASE, it weighs about 23 kg (50 lb) per mat (about 4.1 psf). Just like DURA-BASE, this mat uses an overlapping lip and pin connector manufactured from HDPE with a metal core. The pin requires a one-quarter turn with an Allen-head wrench (supplied by the manufacturer) to lock it in place.

## **Construction**

The test section construction began with the installation of the CH clay subgrade. The CH clay was hauled by dump truck to a concrete-surfaced preparation pad located near Hangar 4 where the material was roto-tilled and processed with water to obtain the needed moisture content required for the desired strength after compaction. The processed material was again hauled by dump truck to Hangar 4 and spread with a bulldozer. Compaction was performed with a 22,679-kg (25-ton) rubber-tired roller using 152-mm (6-in.) lifts for a total installed depth of 610 mm (24 in.). Final compaction was performed with a 10,500-kg (23,150-lb) smooth steel drum vibratory compactor with a dynamic force output of 36 kips at 2,400 rpm to achieve a final CBR value in the range of 8 to 10. Tables 4 and 5 list some of the engineering data obtained during construction of the section.

**Table 4  
Selected Pre- and Post-Traffic Soil Density Values (Dry Densities, pcf)**

Test Item	High-Strength Soil (40-50 CBR)						Medium-Strength Soil (8-10 CBR)						Low-Strength Soil (3-5 CBR)					
	Pre-Traffic Station			Post-Traffic Station			Pre-Traffic Station			Post-Traffic Station			Pre-Traffic Station			Post-Traffic Station		
	15	25	35	15	25	35	15	25	35	15	25	35	15	25	35	15	25	35
<b>Control</b>																		
Nuclear	124.8	123.7	121.4	129.8	127.4	128.6	94.7	91.95	92.35	--	--	--	90.5	90.7	91.4	--	--	--
Sand Cone	142.1	--	146.6	--	--	--	--	--	--	--	--	--	--	--	--	--	--	--
<b>Durabase</b>																		
Nuclear	125.5	130.4	127.4	137.3	130	134	92.3	90.85	92.3	--	--	--	91.2	90.9	88.5	--	--	--
Sand Cone	137.8	--	131.7	--	--	--	--	--	--	--	--	--	--	--	--	--	--	--
<b>MP Mat</b>																		
Nuclear	125.6	128.2	125.4	136.3	134	134.2	93.4	93.1	93.3	95.6	95.8	95	--	--	--	--	--	--
Sand Cone	--	--	--	--	--	--	--	--	--	--	--	--	--	--	--	--	--	--
<b>Rapid Mat</b>																		
Nuclear	129.4	129.7	130.6	135.1	134.4	130.3	Failed High-Strength Soil Tests						Failed High-Strength Soil Tests					
Sand Cone	135.2	--	135.4	--	--	--	Not Tested on Medium-Strength Soil						Not Tested on Low-Strength Soil					
<b>Rolla Road</b>																		
Nuclear	129.6	131.3	130.1	131.6	129.4	128.1	Failed High-Strength Soil Tests						Failed High-Strength Soil Tests					
Sand Cone	--	133.9	133.7	--	--	--	Not Tested on Medium-Strength Soil						Not Tested on Low-Strength Soil					
<b>SP-12</b>																		
Nuclear	121.6	125.3	124.9	126.3	123.1	126.6	Failed High-Strength Soil Tests						Failed High-Strength Soil Tests					
Sand Cone	142	--	131.2	--	--	--	Not Tested on Medium-Strength Soil						Not Tested on Low-Strength Soil					

Notes:  
1. "--" indicates that no data were recorded at this station.  
2. Multiple Nuclear Density Tests at one station were averaged to derive a final value.  
3. Sand Cone Tests were not performed on every section and test. These were performed when convenient and time permitted, to provide some secondary verification of the Nuclear Density Tests. The Nuclear Density Test is used as the standard to determine soil density as less error is involved.

**Table 5  
Selected Pre- and Post-Traffic Soil Strength Values**

Test Item	High-Strength Soil (40-50 CBR)						Medium-Strength Soil (8-10 CBR)						Low-Strength Soil (3-5 CBR)					
	Pre-Traffic Station			Post-Traffic Station			Pre-Traffic Station			Post-Traffic Station			Pre-Traffic Station			Post-Traffic Station		
	15	25	35	15	25	35	15	25	35	15	25	35	15	25	35	15	25	35
<b>Control</b>																		
Field CBR	44	60	44	--	--	--	--	--	--	--	--	--	4.3	4.7	3.5	--	--	--
DCP	38	42	38	44	60	45	8.7	8.7	11.6	8.7	5.8	6	7	7	5	--	--	--
<b>Durabase</b>																		
Field CBR	28	45	43	--	--	--	9.8	--	12.3	--	--	--	--	--	--	--	--	--
DCP	--	--	--	60	70	40	7	8	11.6	--	--	--	4.4	7	5	4.4	7	5
<b>MP Mat</b>																		
Field CBR	--	52	44	100	100	100	--	--	--	--	--	--	--	--	--	--	--	--
DCP	30	25	35	60	60	85	11.6	7	7	7	8.7	8.7	7	5.8	7	--	--	--
<b>Rapid Mat</b>																		
Field CBR	48	--	47	--	--	--	Failed High-Strength Soil Tests						Failed High-Strength Soil Tests					
DCP	48	60	45	60	60	50	Not Tested on Medium-Strength Soil						Not Tested on Low-Strength Soil					
<b>Rolla Road</b>																		
Field CBR	38	--	39	51	--	--	Failed High-Strength Soil Tests						Failed High-Strength Soil Tests					
DCP	45	40	40	--	--	--	Not Tested on Medium-Strength Soil						Not Tested on Low-Strength Soil					
<b>SP-12</b>																		
Field CBR	38	--	48	58	--	--	Failed High-Strength Soil Tests						Failed High-Strength Soil Tests					
DCP	25	27	30	38	35	50	Not Tested on Medium-Strength Soil						Not Tested on Low-Strength Soil					

Notes:  
1. "--" indicates that no data were recorded at this station.  
2. Field CBR values were used as the standard for soil strength in this project. Dynamic Cone Penetrometer (DCP) numbers are included here strictly for comparison and as additional information.  
3. DCP values were estimated from DCP data plots. Multiple DCPs at one station were averaged to arrive at a final value.  
4. Field CBR values were taken from CBR data worksheets. Multiple CBR analyses at one station were averaged to derive a final value.

After the clay subgrade was compacted and finish-rolled, a 152-mm (6-in.) layer of clay gravel was installed over the subgrade. This material was placed at 5 percent moisture content and compacted to a density of 2,390 kg/m<sup>3</sup> or 149 pcf, as measured by ASTM D1556 – Sand Cone Method. The acceptable final field CBR value for the clay gravel was in the range of 40 to 50. Photo 31 shows a field CBR test being conducted on the final clay gravel surface. The clay gravel material properties were also verified using a nuclear densometer and the Dynamic Cone Penetrometer (DCP). The nuclear densometer was used to verify proper compaction effort and moisture content. The DCP was used as a comparison with field CBRs to verify that proper soil strength values were obtained.

Prior to performing a control test (no matting used) or placement of any matting system, the baseline surface profiles for three stations (Stations 15, 25, and 35 – south end to north end) along the traffic lane were collected using a survey rod and level. Photo 32 shows the final clay gravel surface after baseline data collection was completed. Once all baseline data were collected, the matting system to be tested was placed on the test section and assembled according to the vendor's instructions. All matting systems were anchored along both sides using steel rebar pins 0.76 m (2.5 ft) in length. This was done for ease of installation and because all sections tested were relatively small compared with real-world applications. The confining strength for a small area within a large installation was not present and could not be practically simulated. The test section was covered with a black polyethylene membrane during inactive periods and between construction procedures to help ensure that moisture contents in the test section materials remained constant throughout each trafficking phase.

After a series of trafficking tests was completed and rutting failure criteria achieved, the matting system was removed and the final test section profiles were collected. The test section was then reconstituted with a soil-tilling machine, appropriate water was added, and the clay gravel was recompacted until the required CBR value range was achieved. This process continued for all of the matting systems tested on the clay gravel surface, including the control test with no matting placed over the surface.

Upon completion of mat system testing on the clay gravel surface, this layer was removed to expose the CH clay material. The clay material was tilled and recompacted to achieve a uniform layer with a CBR value in the range of 8 to 10. As with the previous testing, the baseline data were collected, the matting system placed and secured, and the trafficking begun. Again, use of the sand cone, field CBR, nuclear densometer, and the DCP allowed for the verification of compaction and required soil strengths (see Tables 4 and 5). The testing for this portion of the project involved only two matting systems, DURA-BASE and MP Mat. Therefore, the reconstitution process was performed only twice, once after the control test and once after the testing of DURA-BASE.

The final phase of testing used the same CH clay system as noted above, but with a final CBR value in the range of 3 to 5. This low strength was obtained by tilling the clay, adding water, and recompacting for a total reconditioned layer of 610 mm (24 in.) in three 203-mm (8-in.) lifts. The same procedures for baseline data and testing used in the previous phase of testing were again applied in this phase. This final phase of testing again involved only two matting systems,

DURA-BASE and MP Mat; therefore, the reconstitution process was performed only twice. This completed the C-130 test section phase of this project.

## Instrumentation

The instrumentation used for this test section consisted of subsurface pressure sensors. Although failure criteria for this project were limited to rut depths and mat system failure, it was determined that gathering information on soil pressures during trafficking could be useful for this and other projects. The sensors used were GeoKon 0.7-MPa (100-psi) pressure cells that were connected by radio telemetry to a data acquisition system located in Hangar 4. The project began with four of these pressure cells. One of these cells was destroyed during its extraction between the testing of the unsurfaced control and the first mat system. The remaining three cells continued to function with some repairs as the testing progressed. The cells were generally placed at a depth of 6 in. below the surface on which the mats were laid (either clay gravel or CH clay). Photo 33 shows a typical pressure cell and a location excavated in the CH clay where it was installed. The cells were placed such that at least one was located below the center of a mat in the middle of the lane, and another in the middle of the lane and below a joint between two mats. In all cases, the cells were placed farther than 10 ft from one another. The pressure cell data were collected at only specified numbers of passes.

## Trafficking and Data Collection

This initial test section evaluation examined the effects of a fully loaded C-130 aircraft on the chosen matting systems. To simulate this loading, the test section used a load cart (modified 2.5-ton truck) fitted with a C-130 tire, loaded with 13,600 kg (30,000 lb) of lead weight. The C-130 tire was inflated to 655 kPa (95 psi), and this combination of load and pressure produced a tire contact area of approximately 3,107 cm<sup>2</sup> (482 in.<sup>2</sup>). The load cart was driven in a channelized traffic pattern to simulate traffic passes over the matting systems. The traffic was confined to a single wheel-width path to allow accelerated trafficking to be performed. Photo 35 shows one of two load carts used on the test section.

In-place cross sections and rut measurement data were typically collected at traffic pass intervals of 0, 10, 25, 50, 75, 100, 250, 500, 750, 1,000, 1,500, 2,500, 5,000, or at the final failure point. These measurements were observed at three observation stations, typically stations 15, 25, and 35 ft, as measured from the south end of the test section. A rod and level, using a permanent benchmark located in Hangar 4, was used to record total lane-width cross sections at each station. A 10-ft aluminum straight edge was used to obtain measurements of the total rut depth. Measurement intervals were modified as needed based on observations and differences in failure rates and failure modes. Baseline data were recorded prior to the placement of the matting system, and final cross sections and rut measurements were taken after the matting system had failed and was removed from the test section. Rut and cross section data collected during traf-

ficking required the use of a small skid-steer multipurpose machine to provide a positive compression force, using its front wheels, to deform the mat into the rut present at the measurement interval. The strength and stiffness of the DURA-BASE required the use of the larger front-end loader to provide this same positive compression force. This practice is shown in use on the SP-12 matting system in Photo 36.

## Failure Criteria

Failure was achieved once the total rut depth (crest to trough of the rut) reached a value of 76.2 mm (3 in.) or greater or when a minimum of 20 percent of the mat system experienced severe damage or breakage. This failure value was measured with the mat in place, using the rod and level and the rut bar, described in the following section. The mats were not removed from the subgrade until the failure condition was reached. Photo 34 shows measurement of the final rut depth after the removal of the Rapid Mat system from the clay gravel surface. The target for a mat to pass this evaluation was  $\geq 2,000$  passes with less than 76.2 mm (3 in.) of total rut with the mat in place over the soil. The rut data for each test item are shown in Figures 4 through 6.

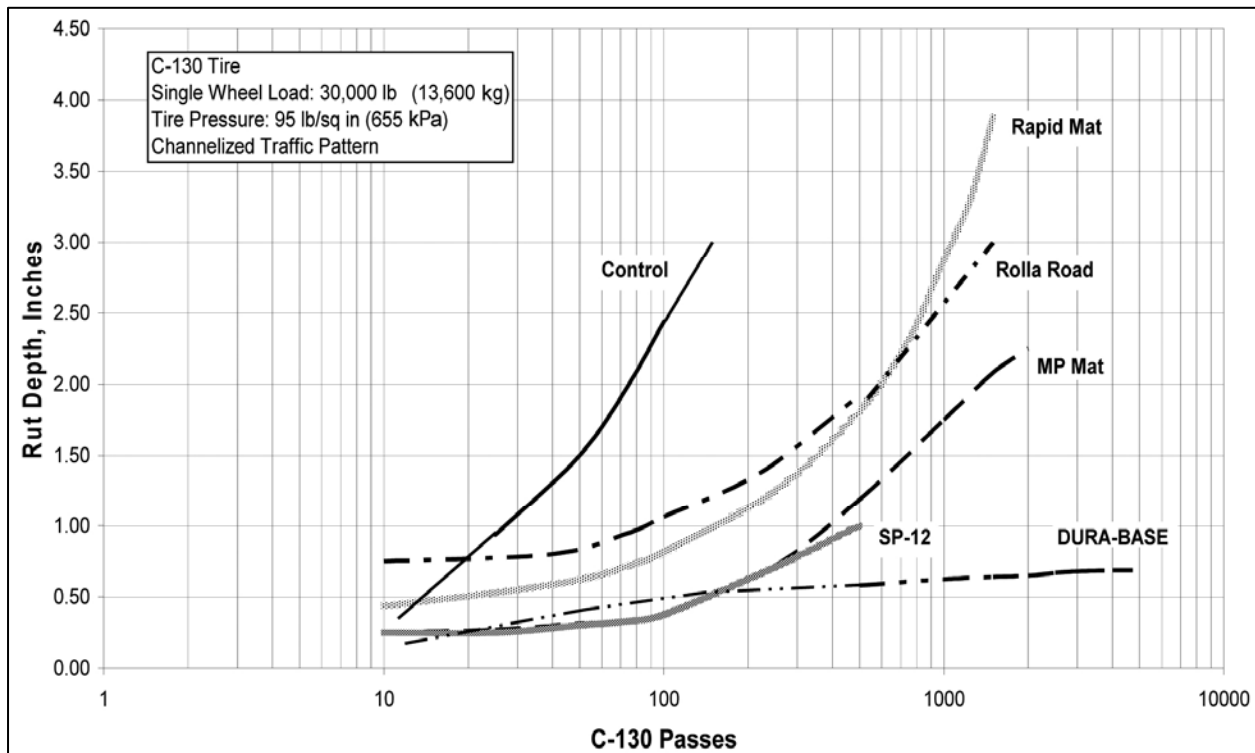

Figure 4. Rut depth for high-strength subgrade (40 to 50 CBR) test items

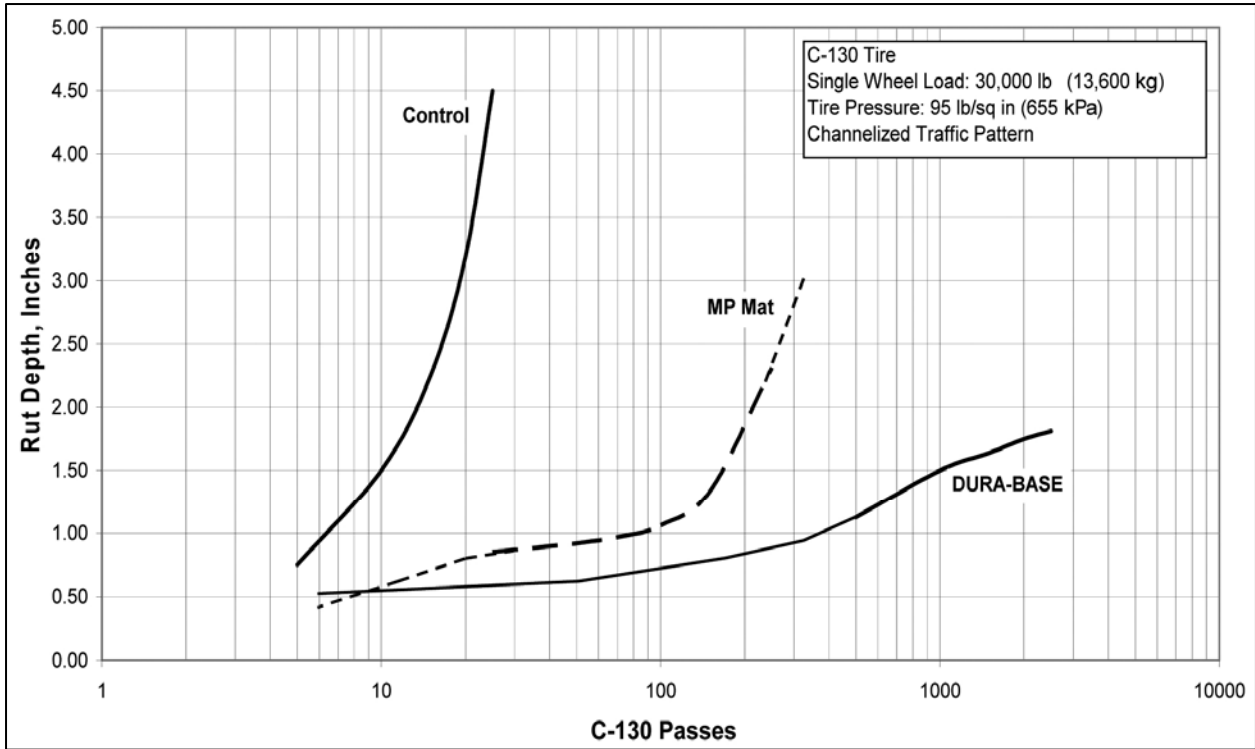

Figure 5. Rut depth for medium-strength subgrade (8 to 10 CBR) test items

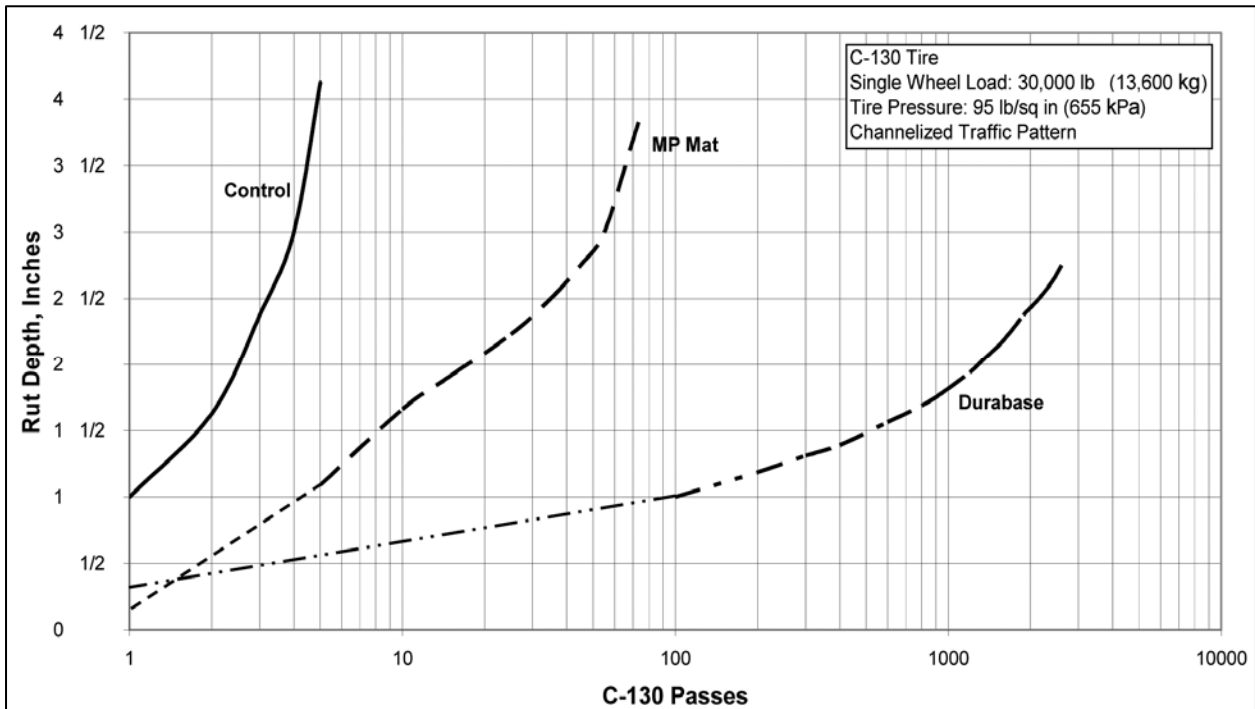

Figure 6. Rut depth for low-strength subgrade (3 to 5 CBR) test items



# 4 Test Section Results

---

## General Summary

Both the Rapid Mat and Rolla Road failed during the first round (high-strength subgrade, 40 to 50 CBR) as the result of excessive bow-wave reactions during traffic tests. These two mats simply did not offer the structural rigidity and strength to prevent early excessive rutting. The SP-12 Mat showed great potential, but as discussed in Chapter 3 of this report, this mat failed because of mechanical problems and, at the time of testing, was still considered a prototype in the final stages of development. Only the DURA-BASE and the MP Mat succeeded in the first round of testing.

The second round of test section evaluations examined the performance of those matting systems passing the first round on a medium-strength (8 to 10 CBR) subgrade. DURE-BASE again showed an ability to carry the heavy C-130 loads well past the typical contingency airfield traffic requirements. The MP Mat demonstrated an ability to carry the heavy C-130 loads for approximately 330 passes before allowing severe rutting. It was estimated that the DURA-BASE would more than likely pass the third round of evaluations with no difficulty, and so it was decided to carry the MP Mat to the final round in order to compare it with the DURA-BASE and the control, that is, to allow a full spectrum of data to be gathered on both of these matting systems.

The third and final round of test section evaluations used a low-strength soil with a CBR of 3 to 5. The DURA-BASE, as expected, performed well even in this scenario of very low subgrade support. The MP Mat, as anticipated, did not allow for as many passes as the DURA-BASE did before reaching the rutting limit of 76 mm (3 in.), but the data gathered qualified this mat for a certain range of service in the field under low soil strength conditions.

As described in Chapter 3, “Rapid MOG Enhancement Test Section,” pressure cells were installed in this test section in an attempt to gather soil pressure data during the trafficking phases of testing. As stated, one of the four cells was destroyed during extraction. As the project progressed, the other three cells were damaged by loading and shear forces or were damaged during extraction. Since the data collected were incomplete and could not be properly analyzed for repeatable trends, these data are not included in this report.

Tables 4 and 5 list some quality control data obtained during construction, baseline, and posttest evaluation activities. Figure 7 shows a plan layout of the test section as to its location within the Hangar 4 Facility in Vicksburg, MS. In addition, Figures 8-19 present plots of rut depth versus C-130 passes for each soil subgrade strength analyzed and cross-section plots at different pass levels of the C-130 wheel on each mat for each soil strength.

The following paragraphs provide details of the performance of each mat tested during this evaluation. The results given are based upon visual observations and deflection measurements made during trafficking.

### Control

During each phase of testing, a control section was included to compare the rutting of the soil with no matting systems applied to that with matting systems applied. With a high-strength subgrade (40 to 50 CBR), the control section reached a rut failure ( $\geq 3$  in. rut) at approximately 105 passes. During the medium-strength subgrade analysis (8 to 10 CBR), the control section failed at approximately 25 passes. Finally, using the low-strength subgrade (3 to 5 CBR), the control section achieved rut failure at approximately 5 passes of a C-130 wheel load.

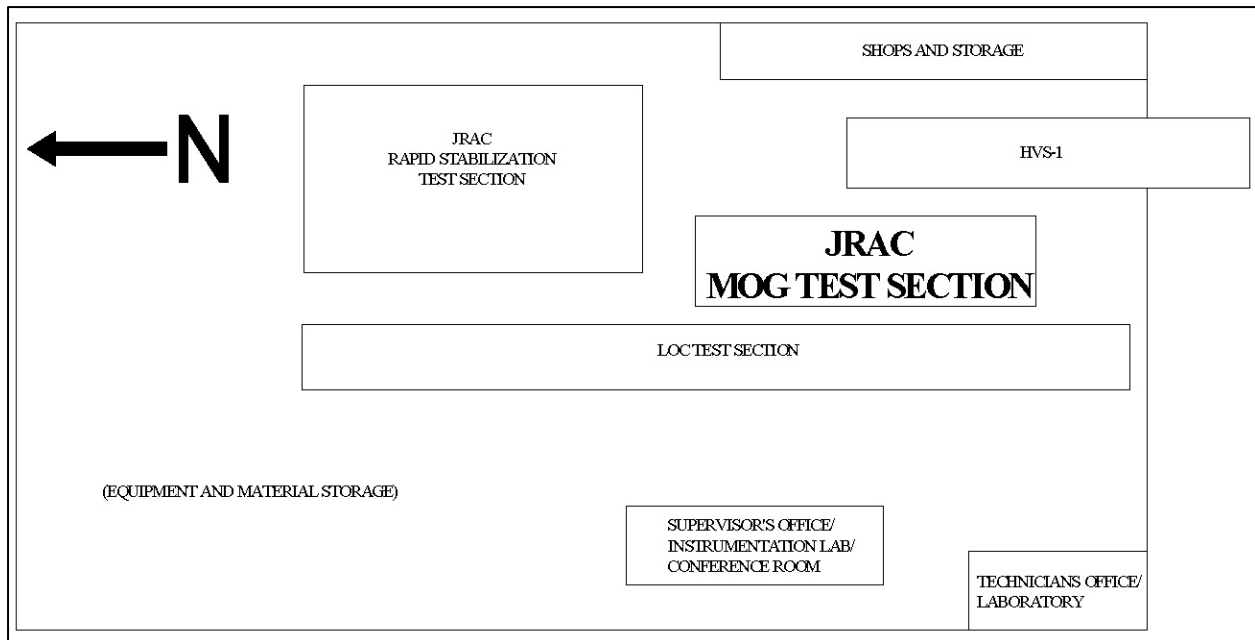

Figure 7. Hangar 4 Pavement Testing Facility test section layout

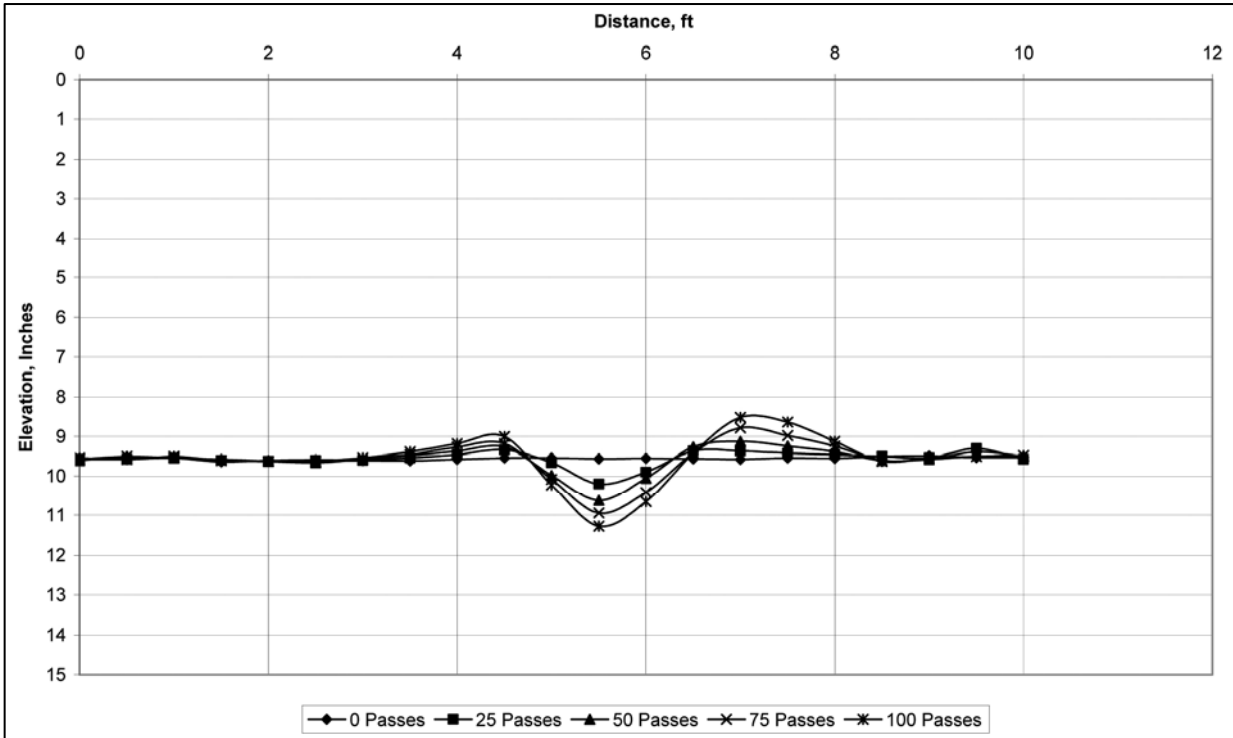

Figure 8. Permanent surface deformation cross section for control (no mat) on high-strength subgrade (40 to 50 CBR)

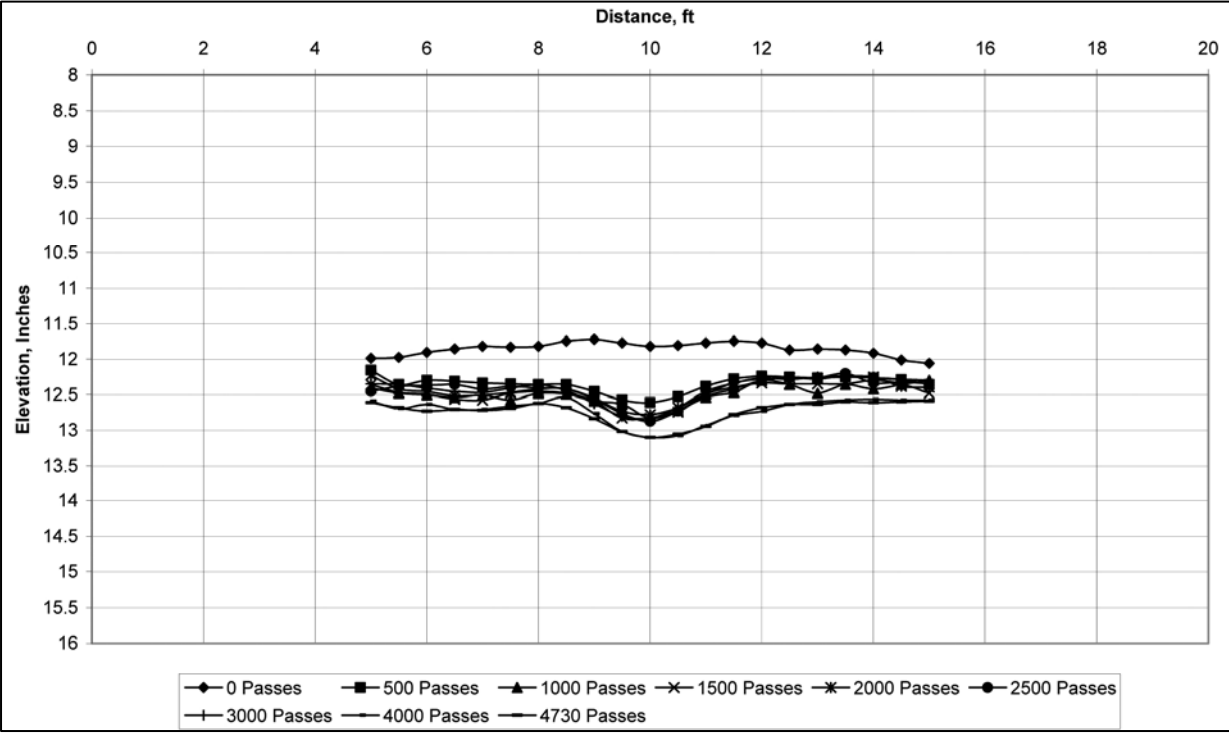

Figure 9. Permanent surface deformation cross section for DURA-BASE on high-strength subgrade (40 to 50 CBR)

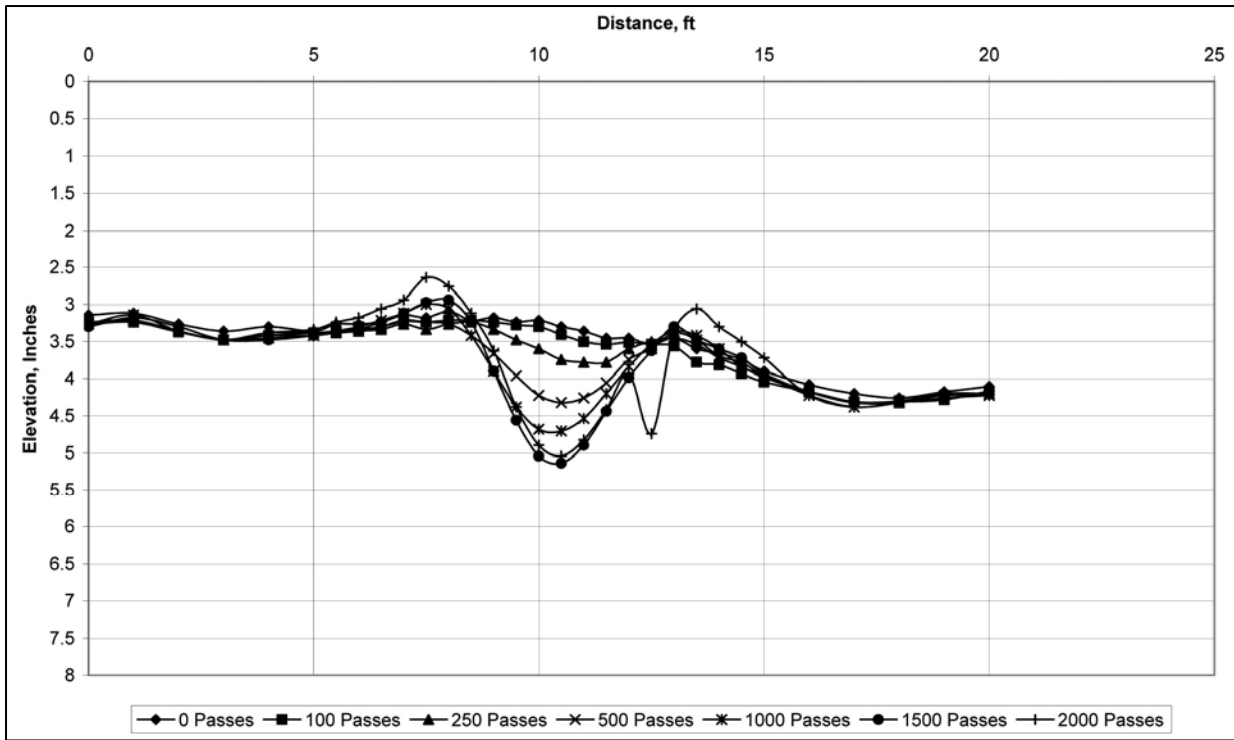

Figure 10. Permanent surface deformation cross section for MP Mat on high-strength subgrade (40 to 50 CBR)

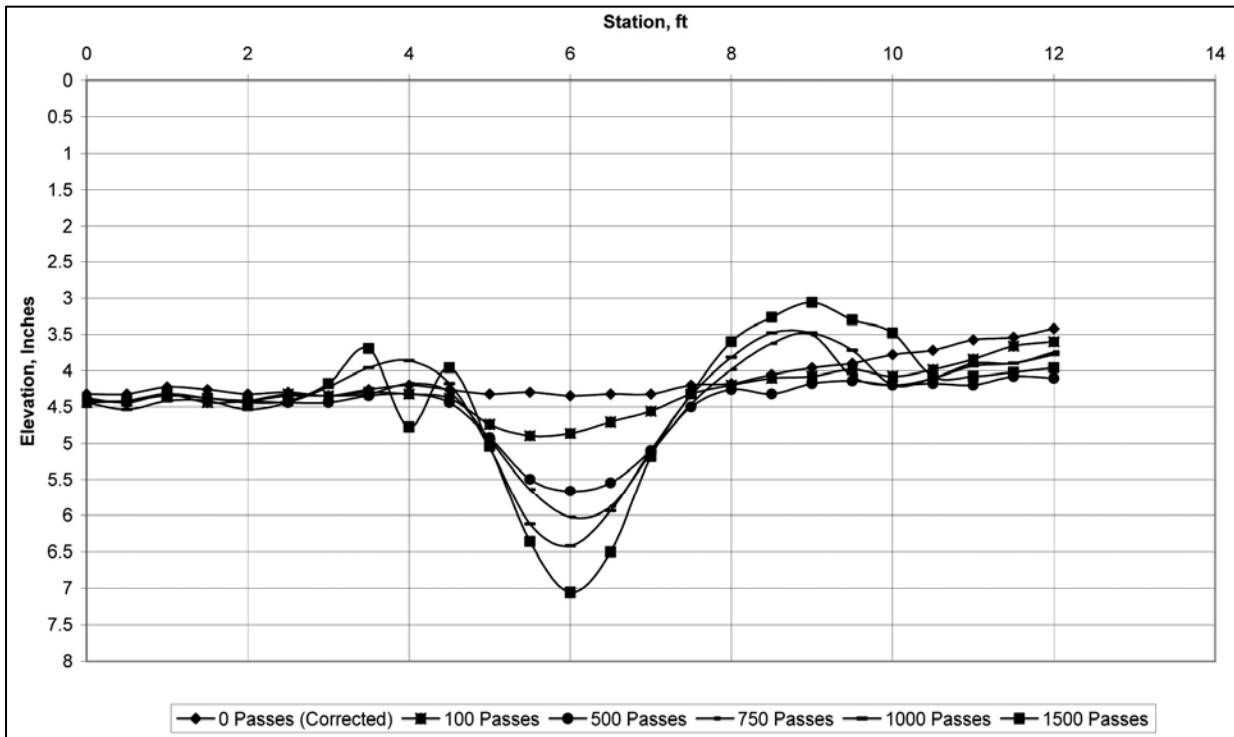

Figure 11. Permanent surface deformation cross section for Rapid Mat on high-strength subgrade (40 to 50 CBR)

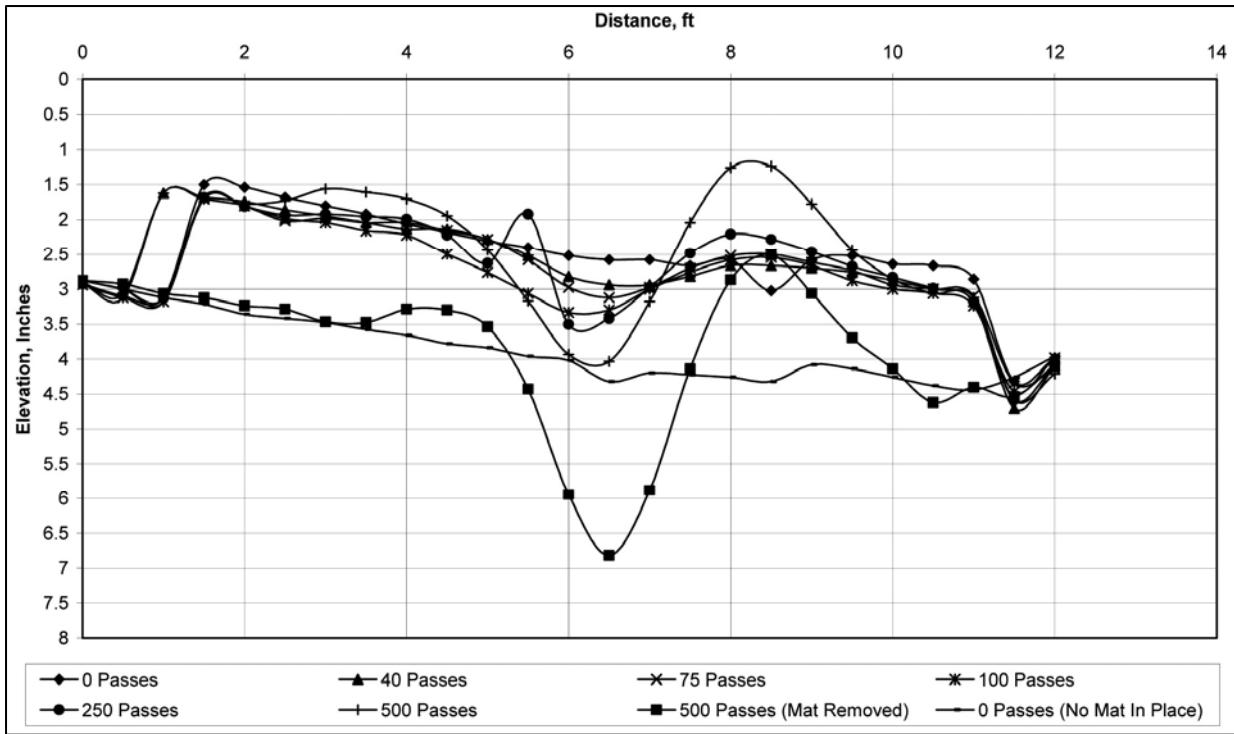

Figure 12. Permanent surface deformation cross section for Rolla Road on high-strength subgrade (40 to 50 CBR)

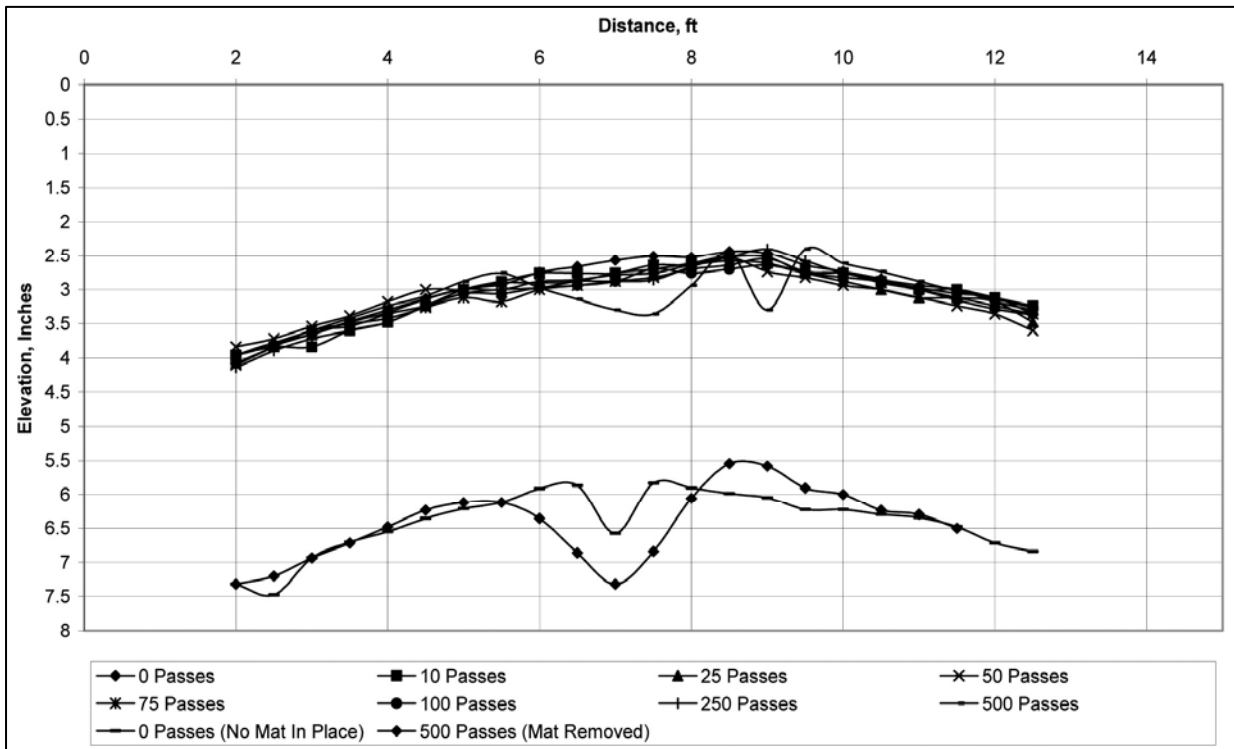

Figure 13. Permanent surface deformation cross section for SP-12 mat on high-strength soil (40 to 50 CBR)

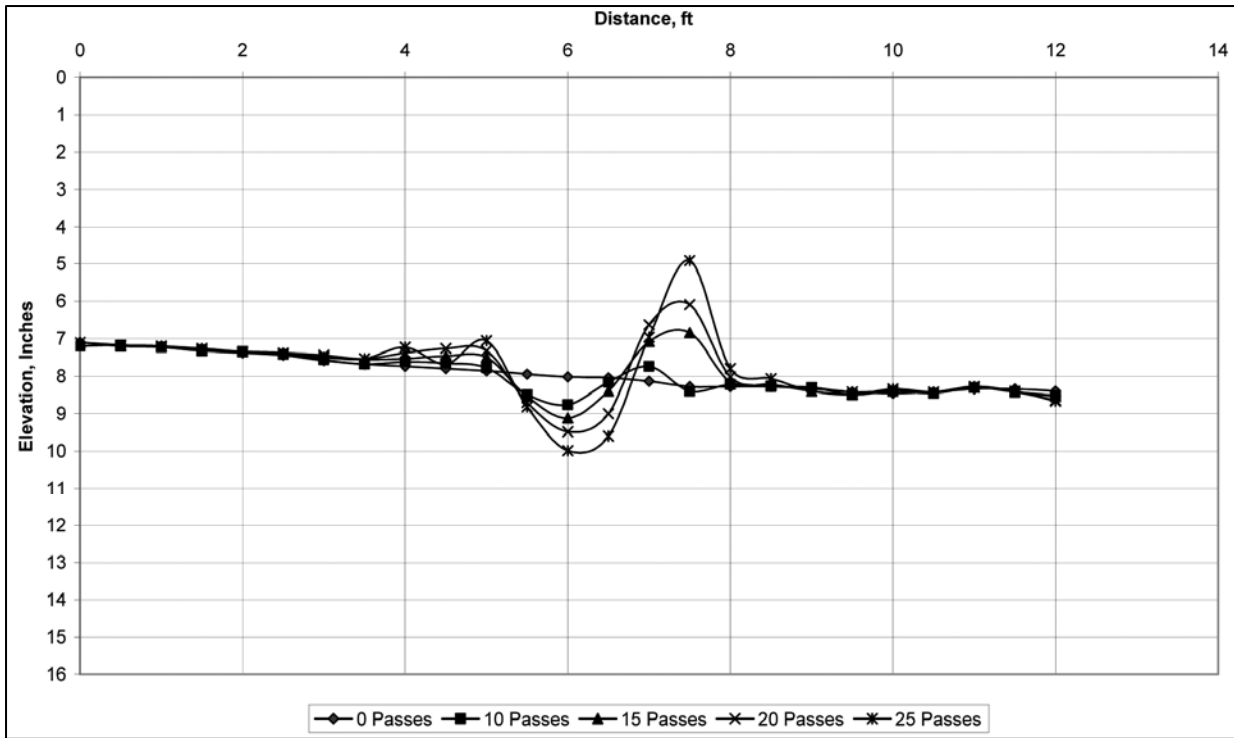

Figure 14. Permanent surface deformation cross section for control (no mat) on medium-strength soil (8 to 10 CBR)

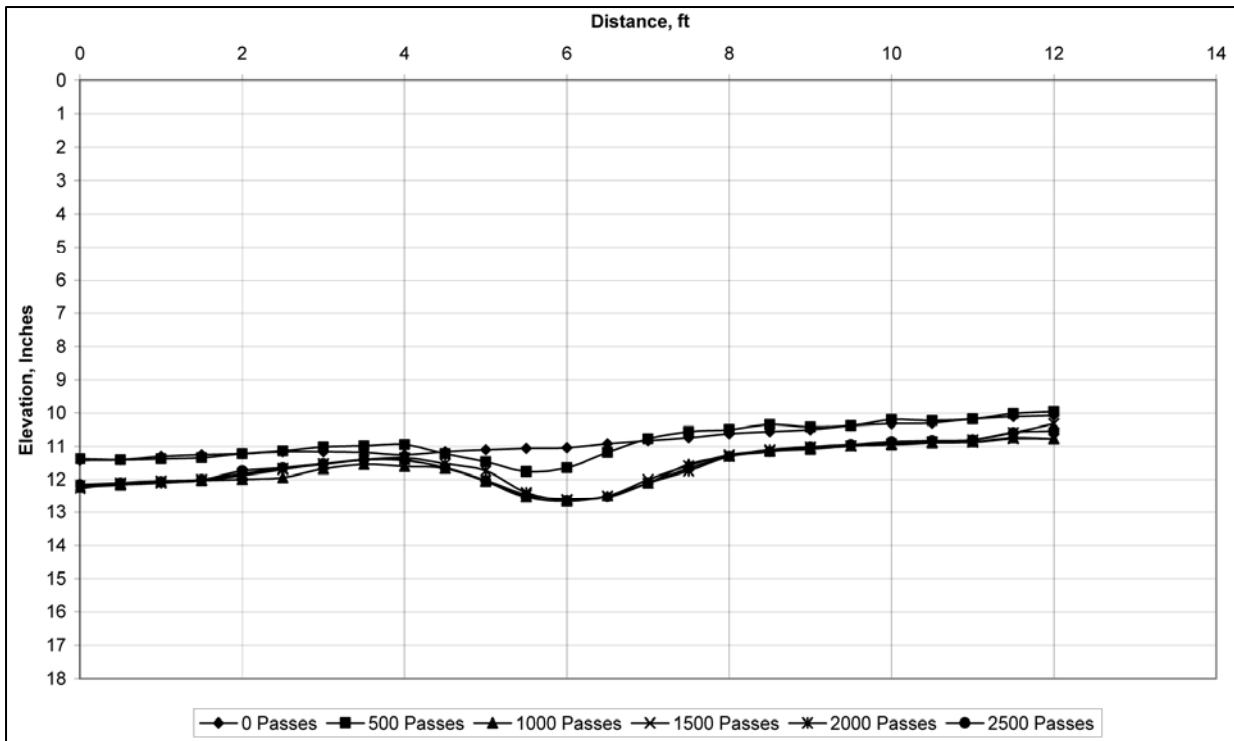

Figure 15. Permanent surface deformation cross section for DURA-BASE on medium-strength soil (8 to 10 CBR)

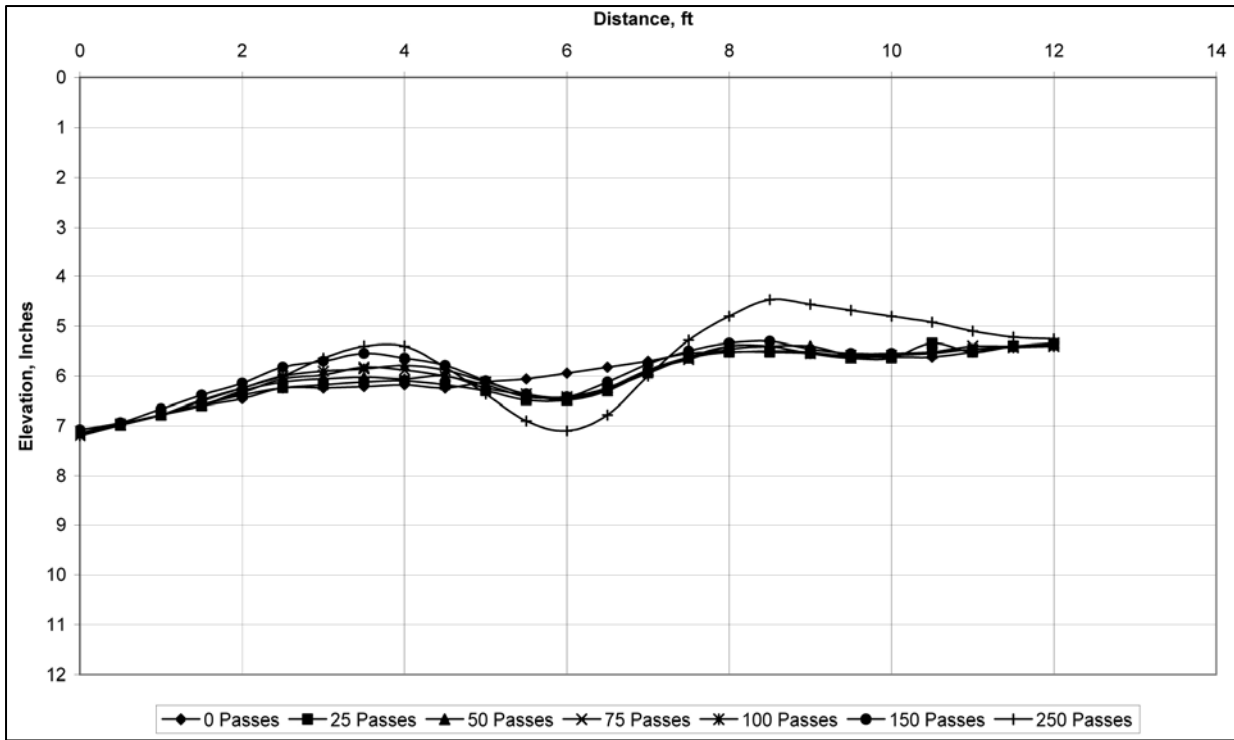

Figure 16. Permanent surface deformation cross section for MP Mat on medium-strength soil (8 to 10 CBR)

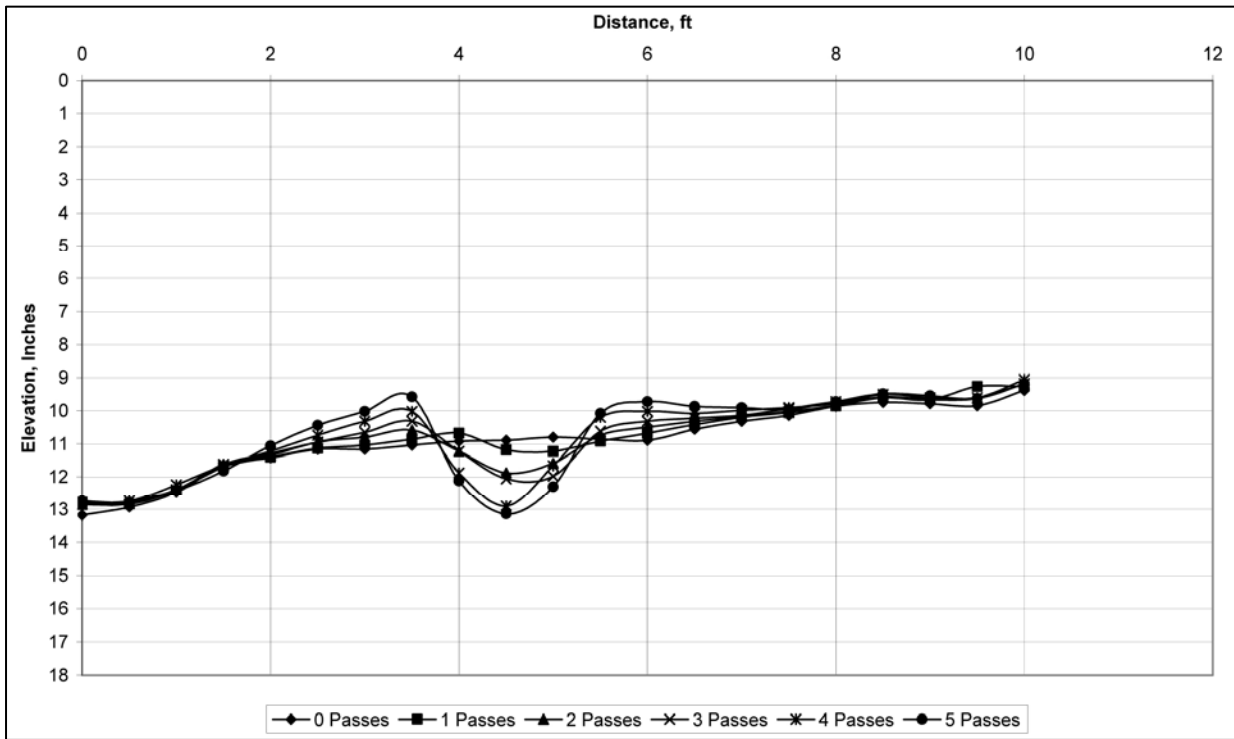

Figure 17. Permanent surface deformation cross section for control (no mat) on low-strength soil (3 to 5 CBR)

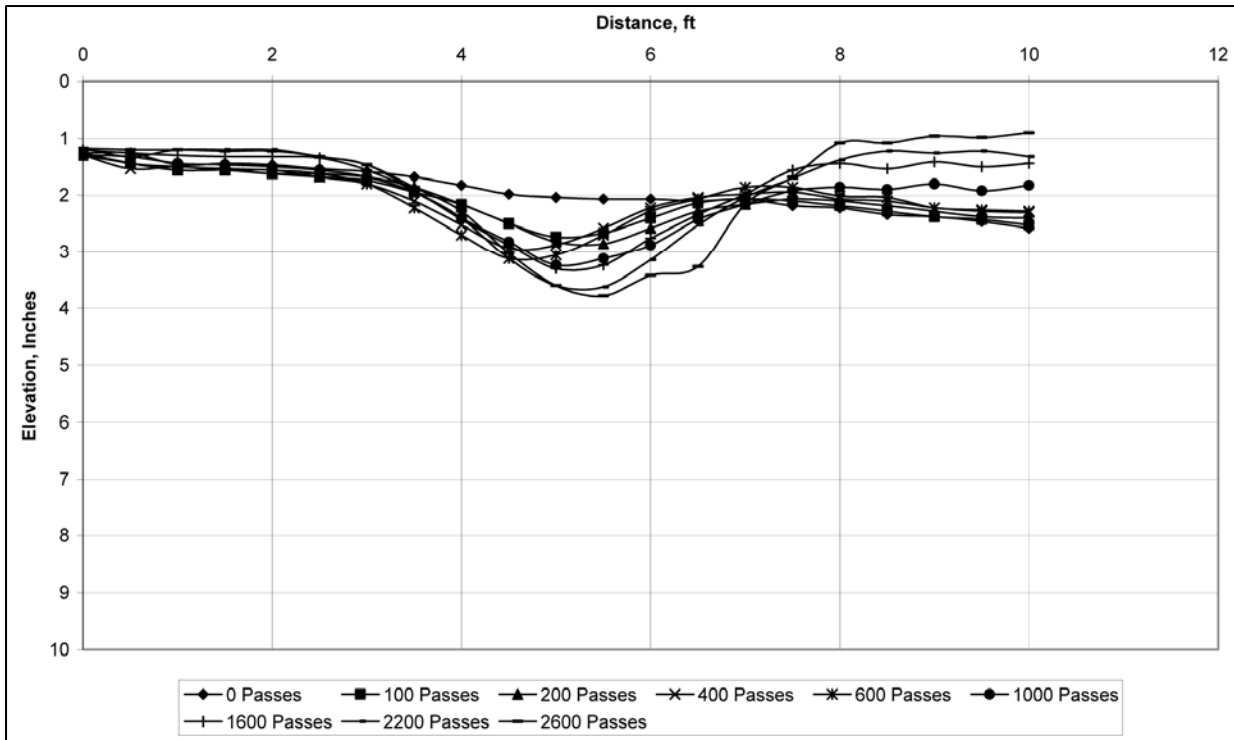

Figure 18. Permanent surface deformation cross section for DURA-BASE on low-strength soil (3 to 5 CBR)

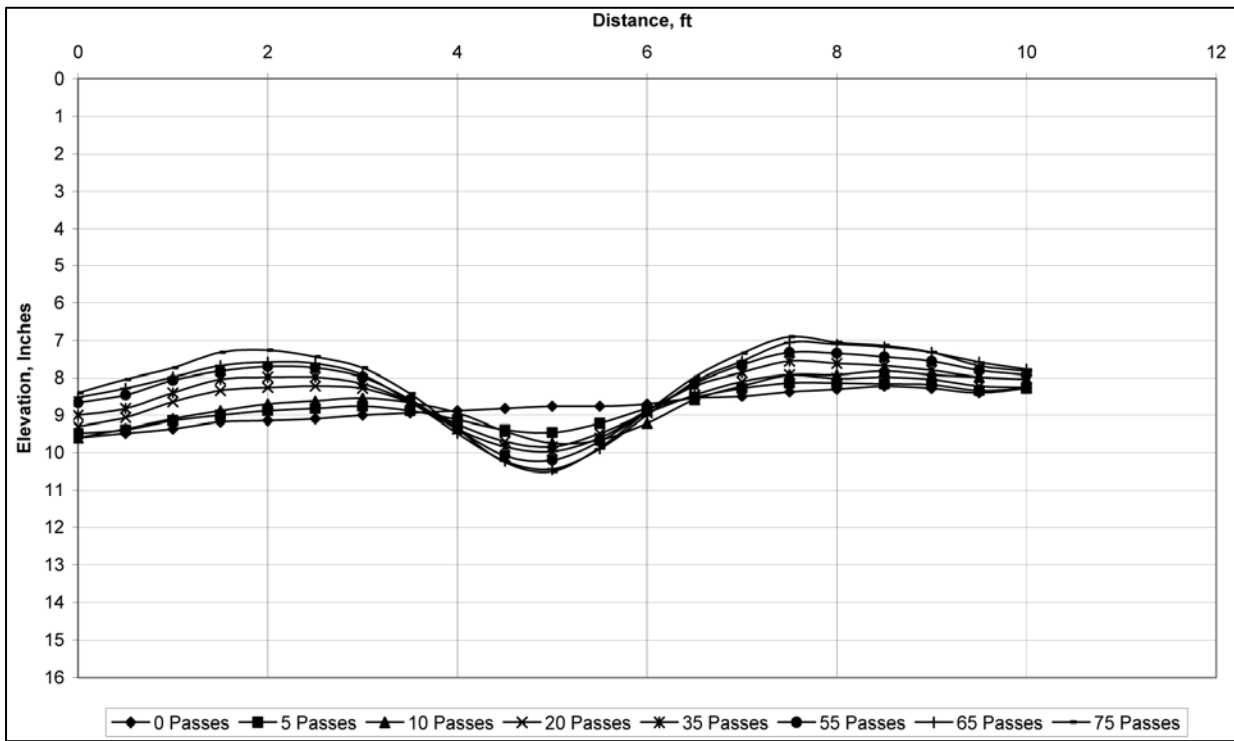

Figure 19. Permanent surface deformation cross section for MP Mat on low-strength soil (3 to 5 CBR)



## **DURA-BASE**

The DURA-BASE matting system performed very well, allowing well over 2,000 passes of the load cart under all the soil conditions investigated with less than 76.2 mm (3 in.) of mat deflection. The mat surface did show signs of traffic and wear by the end of the investigation, but even with this wear, the surface still offered ample traction. The only major sign of failure was some permanent deformation in the mat's midsection during the final stages of testing. The mats exhibited no tears, ruptures, or pin connection failures during the entire investigation.

## **Multi-Purpose Mat**

The MP Mat, although not as resilient as the DURA-BASE, performed well during the test section evaluations. This matting system was able to withstand the minimum 2,000 passes with less than 76.2 mm (3 in.) of mat deflection for the 40 to 50 CBR soil subgrade (high-strength subgrade). The mats did show some large secondary deflections (away from the traffic path) once the point of deflection failure was approaching. This reaction to the progressive rutting of the weak soil beneath the mat caused minor pin problems during the second and third stages of testing (8 to 10 CBR and 3 to 5 CBR, respectively) in which pin popouts occurred (see Photo 37). These popouts totaled less than 10 percent of the total pins installed, and the failure of this small number of pins did not constitute failure of the mat in the test section. In addition, there were several pins within the system that showed signs of minor movement within the connection, but none of these pins failed prior to test completion (see Photo 38). MP Mat allowed 330 passes before reaching the failure criteria during the medium-strength (8 to 10 CBR) subgrade testing and sustained 55 passes before failure during the low-strength (3 to 5 CBR) subgrade testing.

## **Rapid Mat (FFM)**

Rapid Mat (FFM) tested poorly during this evaluation, reaching the failure criteria of 76.2 mm (3 in.) in 1,010 passes during the high-strength subgrade testing. Because it performed so poorly, it was not evaluated on medium- or low-strength subgrades. The mats offered little or no structural support and did not improve the soil strength condition for heavy aircraft traffic. During trafficking, deep rutting under the mats caused the outer sections of the mats to exhibit large deflections or bow-wave action. These mats are not recommended for use in MOG enhancement activities but should be used only for FOD prevention.

## **Rolla Road Mark III**

Rolla Road tested poorly during this evaluation as well, reaching the failure criteria with only 1,050 passes during the high-strength subgrade testing. Like Rapid Mat, it was not advanced to the medium- or low-strength subgrade tests. It provided similar support and reaction to load as the Rapid Mat. It offered very little structural support to the soil surface and did little to improve the

load-carrying capability of the soil. Similar to the Rapid Mat, this mat also produced the bow-wave action of the outer sections of the mat as the rut underneath became greater. These mats are not recommended for use in MOG enhancement activities.

### **SP-12 Mat**

The SP-12 Mat appeared to perform well on the high-strength subgrade (40 to 50 CBR), allowing 500 passes with only 25.4 mm (1 in.) of rut. The mat tested was a prototype model developed and trial-produced by the manufacturer and shipped to ERDC specifically for this test. This mat is still in the developmental phases, and during testing it was found that the welding between the “skin” and “ribbing” or “core” of the mat was faulty, and contact between the two pieces was less than 20 percent. These flaws caused the mat to fail mechanically before failure due to rutting occurred. It is therefore not appropriate at this time to pass final judgment on this product. The initial testing of this product indicates a mat system with much potential, but the flaws with the manufacturing process must be resolved before further testing and conclusions can be formed.

## 5 Conclusions

---

The focus of this research and evaluation effort was to investigate the use of currently available matting systems to establish or expand contingency airfield taxiways and parking aprons in austere environments. The evaluations began with field demonstrations at Fort Campbell, KY, of four matting systems used to prevent the brownout conditions caused by helicopter landing and taxiing operations on unsurfaced helipads. The project completed its next milestone in the fall of 2003, with the conclusion of the test section evaluations at the ERDC Pavement Test Facility in Hangar 4 at Vicksburg, MS, where five pavement matting systems were subjected to simulated C-130 aircraft traffic.

The Fort Campbell exercise showed that the Mobi-Mat and MP Mat systems had high potential for use as cover on contingency helipads. The final system chosen by the Army was the Mobi-Mat, because of its low logistical characteristics, light weight, and ease in installation. Neither the Mobi-Mat or SUPA-TRAC systems offered much structural support over soft, low bearing-capacity soils; thus, these two mats were not chosen for the ERDC test section experiments.

The conclusions reached at the end of this first phase of the Rapid MOG Enhancement project are based upon two contingency airfield scenarios: helicopter landing zones with emphasis on preventing brownout conditions and rapidly constructed taxiways and parking aprons for C-130 traffic. The following conclusions are given within the general context of these two operational scenarios:

*a.* Contingency helipads:

(1) SUPA-TRAC is a relatively quick and simple matting system to assemble, but it has a potential for structural damage under even a limited number of helicopter operations. This matting system is not recommended for use as a contingency helipad.

(2) DURA-BASE is a very durable matting system that is relatively simple to assemble, but the size and weight of the panels requires a heavy forklift for assembly. The heavy weight of these mats also makes them a logistical liability in terms of getting them to the desired location. For these logistical restrictions alone, the DURA-BASE system is not recommended for widespread applications as a contingency helipad system.

(3) The MP matting system is a versatile system capable of meeting the demands of a contingency helipad. There is a moderate amount of labor involved

in the assembly process, requiring a few hand tools and limited training. This matting system should be considered for use as contingency helipad surfacing.

(4) Mobi-Mat is a very simple and quickly assembled contingency surfacing system that is relatively light and logistically friendly. The highly flexible nature of this open-textured, woven mat is ideal for molding to rough terrain, but it has very little load-bearing capacity. When added structural capacity is not an issue, this matting system's logistically friendly nature and simple design make it a good choice for reducing brownout conditions at contingency helipads.

*b.* C-130 contingency airfield MOG enhancement:

(1) The Rapid Mat (Folded Fiberglass Mat) and Rolla Road Mark III systems do not possess the stiffness and structural integrity under C-130 loads to be considered for applications in most contingency airfield MOG enhancement scenarios.

(2) The SP-12 Mat system showed potential for application under C-130 loading, but the current configuration caused the mats to fail structurally early in the traffic tests. With significant improvements in the structural integrity from the manufacturing process, this mat system may be considered for C-130 contingency airfield applications, but until such time, it will not be included in future testing and evaluation exercises.

(3) The DURA-BASE matting system performed very well throughout the test section evaluations. This system should be considered for use under C-130 contingency airfield scenarios, but its weight and MHE requirements will likely be a deterring factor in many cases.

(4) The MP Mat performed very well under the high-strength subgrade support conditions, moderately well under the medium-strength subgrade conditions, and provided only minimal improvements in the low-strength subgrade condition tests. This implies that the MP Mat can be used for C-130 contingency airfield taxiway and parking apron construction, but the underlying soil strength will be a limiting design factor.



Photo 1. Brownout conditions resulting from helicopter operations in dusty environment



Photo 2. Soldiers of the 887th LE Company await their team assignments prior to construction of mat test sections at Aardvark LZ





Photo 3. Unloading rolls of Mobi-Mat from shipping crates



Photo 4. Rolling out Mobi-Mat before anchoring to adjacent panel and staking edges





Photo 5. Stretching out Mobi-Mat panel before anchoring



Photo 6. Hammering corner stakes into Mobi-Mat panels





Photo 7. Completed Mobi-Mat helipad. (Note tops of pins used to hold it in place)



Photo 8. Large forklift used to place each DURA-BASE panel





Photo 9. Bar tools used to align connector pinholes during placement



Photo 10. Dual-use bar tool used to align panels and lock in connector pins





Photo 11. Panels of SUPA-TRAC being carried and placed by soldiers



Photo 12. Snapping panels of SUPA-TRAC into place with boot heel





Photo 13. Tapping in SUPA-TRAC connector pins

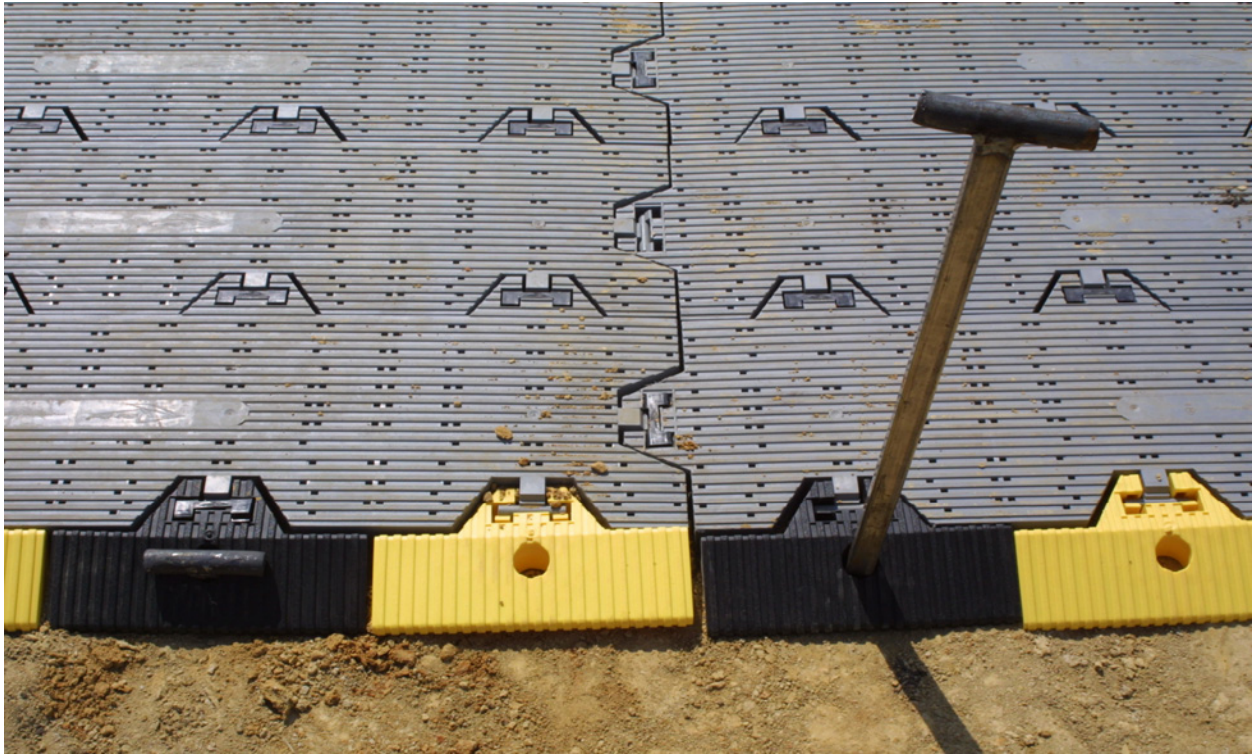

Photo 14. SUPA-TRAC with edge pieces and pins used to tie down the edges



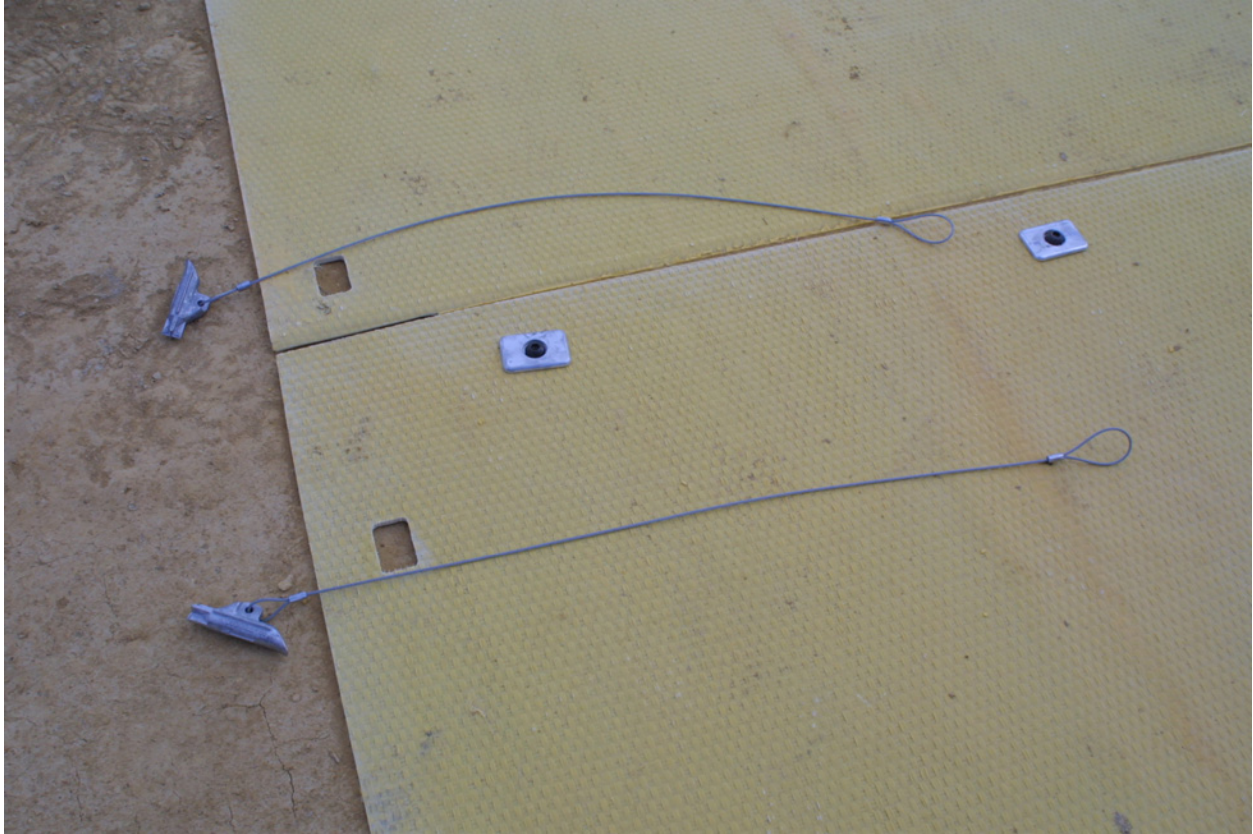

Photo 15. Duckbill anchors used to hold MP Mat system in place



Photo 16. Hand placement and alignment of MP Mat panels





Photo 17. Placing MP Mat connector pins and locking pins with electric impact wrench





Photo 18. Locking MP Mat connector pins with socket wrench





Photo 19. Gasoline-powered jackhammer used to drive duckbill anchors into ground





Photo 20. Aerial view of contingency helipad matting test sections at Aardvark LZ



Photo 21. CH-47 Chinook helicopter landing on Mobi-Mat helipad





Photo 22. UH-60 Blackhawk operating on DURA-BASE helipad



Photo 23. CH-47 Chinook operating on SUPA-TRAC helipad





Photo 24. Isolated structural damage to SUPA-TRAC matting system at helipad edge



Photo 25. MP Mat helipad diffusing dust cloud as UH-60 Blackhawk approaches helipad





Photo 26. Installing DURA-BASE matting system



Photo 27. Installing 5-ply MP matting system





Photo 28. Installing Rapid Mat (FFM) matting system



Photo 29. Installing Rolla-Road matting system





Photo 30. Installing SP-12 matting system



Photo 31. Field CBR test setup





Photo 32. Unsurfaced control test section (high subgrade strength) is complete and awaits traffic



Photo 33. 100-psi GeoKon Pressure Cell awaits placement in CH clay





Photo 34. Measuring final rut depth on the Rapid Mat test (mat has been removed)



Photo 35. Loaded C-130 load cart performing traffic test on DURA-BASE matting





Photo 36. Using the skid-steer multipurpose machine to measure mat in-place rutting



Photo 37. Secondary deflection of MP Mat on low-strength soil (3 to 5 CBR)





Photo 38. Movement of MP Mat pin within connection. Pin did not fail. (Low-strength soil, 3 to 5 CBR)

# REPORT DOCUMENTATION PAGE

*Form Approved*  
*OMB No. 0704-0188*

Public reporting burden for this collection of information is estimated to average 1 hour per response, including the time for reviewing instructions, searching existing data sources, gathering and maintaining the data needed, and completing and reviewing this collection of information. Send comments regarding this burden estimate or any other aspect of this collection of information, including suggestions for reducing this burden to Department of Defense, Washington Headquarters Services, Directorate for Information Operations and Reports (0704-0188), 1215 Jefferson Davis Highway, Suite 1204, Arlington, VA 22202-4302. Respondents should be aware that notwithstanding any other provision of law, no person shall be subject to any penalty for failing to comply with a collection of information if it does not display a currently valid OMB control number. **PLEASE DO NOT RETURN YOUR FORM TO THE ABOVE ADDRESS.**

<b>1. REPORT DATE (DD-MM-YYYY)</b> January 2005		<b>2. REPORT TYPE</b> Report 1 of a series		<b>3. DATES COVERED (From - To)</b>							
<b>4. TITLE AND SUBTITLE</b>  Rapid Maximum-On-Ground (MOG) Enhancement Technologies; Report 1, Matting Systems for Contingency Helipads and C-130 Test Sections				<b>5a. CONTRACT NUMBER</b>							
				<b>5b. GRANT NUMBER</b>							
				<b>5c. PROGRAM ELEMENT NUMBER</b>							
<b>6. AUTHOR(S)</b>  Gary L. Anderton and Chad A. Gartrell				<b>5d. PROJECT NUMBER</b>							
				<b>5e. TASK NUMBER</b>							
				<b>5f. WORK UNIT NUMBER</b>							
<b>7. PERFORMING ORGANIZATION NAME(S) AND ADDRESS(ES)</b>  Geotechnical and Structures Laboratory U.S. Army Engineer Research and Development Center 3909 Halls Ferry Road, Vicksburg, MS 39180-6199				<b>8. PERFORMING ORGANIZATION REPORT NUMBER</b>  ERDC/GSL TR-05-2							
<b>9. SPONSORING / MONITORING AGENCY NAME(S) AND ADDRESS(ES)</b> U.S. Army Corps of Engineers Washington, DC 20314-1000				<b>10. SPONSOR/MONITOR'S ACRONYM(S)</b>							
				<b>11. SPONSOR/MONITOR'S REPORT NUMBER(S)</b>							
<b>12. DISTRIBUTION / AVAILABILITY STATEMENT</b> Approved for public release; distribution is unlimited.											
<b>13. SUPPLEMENTARY NOTES</b>											
<b>14. ABSTRACT</b>  <p>The U.S. Army Engineer Research and Development Center (ERDC) began a 6-year comprehensive research, development, and demonstration program in 2002 entitled the Joint Rapid Airfield Construction (JRAC) program. The JRAC program is focused on providing engineering tools and systems that will dramatically increase the U.S. military's contingency airfield upgrade and construction capabilities. One project within the JRAC program is entitled "Rapid MOG Enhancement Technologies." The term MOG refers to the maximum-on-ground rating, or the number of aircraft that can remain on the ground at any one time at a given airfield. Rapid expansion of existing airfield parking areas or construction of new aircraft parking space is the focus of the Rapid MOG Enhancement Technologies project.</p> <p>This report describes the results of an experiment on pavement matting systems for use in contingency airfield operations. In particular, the matting systems were evaluated for their ability to carry military helicopter and C-130 cargo aircraft loads over semi-prepared soil foundations. The scope of these evaluations included a contingency helipad field trial and a series of controlled test sections with C-130 traffic loads.</p> <p style="text-align: right;">(Continued)</p>											
<b>15. SUBJECT TERMS</b> <table style="width: 100%; border: none;"> <tr> <td style="width: 33%;">Airfield matting</td> <td style="width: 33%;">JRAC</td> <td style="width: 33%;">Rapid soil stabilization</td> </tr> <tr> <td>Apron matting</td> <td>Maximum-on-ground enhancement</td> <td>Taxiway matting</td> </tr> </table>						Airfield matting	JRAC	Rapid soil stabilization	Apron matting	Maximum-on-ground enhancement	Taxiway matting
Airfield matting	JRAC	Rapid soil stabilization									
Apron matting	Maximum-on-ground enhancement	Taxiway matting									
<b>16. SECURITY CLASSIFICATION OF:</b>			<b>17. LIMITATION OF ABSTRACT</b>	<b>18. NUMBER OF PAGES</b>	<b>19a. NAME OF RESPONSIBLE PERSON</b>						
<b>a. REPORT</b> UNCLASSIFIED	<b>b. ABSTRACT</b> UNCLASSIFIED	<b>c. THIS PAGE</b> UNCLASSIFIED			<b>19b. TELEPHONE NUMBER (include area code)</b>						

#### **14. ABSTRACT (continued)**

Results of the contingency helipad field trial indicated that all four mat systems evaluated significantly reduced foreign object debris and “brownout” conditions from helicopters; however, the prescribed logistical requirements lead to the Mobi-Mat system as the best choice. The C-130 test section experiments indicated that two of the five mat systems evaluated should not be given further consideration, one mat showed promise but needs further manufacturing refinements, one mat carried the C-130 loads very well but is somewhat heavy, and the final mat carried C-130 loads well with limitations on soil strength and number of aircraft passes.