

TA7  
W34m  
no.  
GL-92-32  
c.3

US Army Corps  
of Engineers

MISCELLANEOUS PAPER GL-92-32

# REANALYSIS OF MULTIPLE-WHEEL LANDING GEAR TRAFFIC TESTS

by

Richard G. Ahlvin, Jim W. Hall, Jr.

Geotechnical Laboratory

DEPARTMENT OF THE ARMY  
Waterways Experiment Station, Corps of Engineers  
3909 Halls Ferry Road, Vicksburg, Mississippi 39180-6199

**US-CE-C** PROPERTY OF THE  
UNITED STATES GOVERNMENT

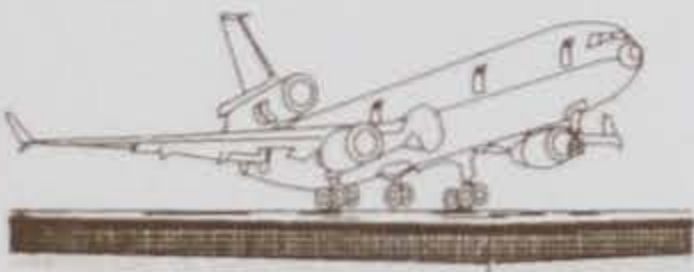
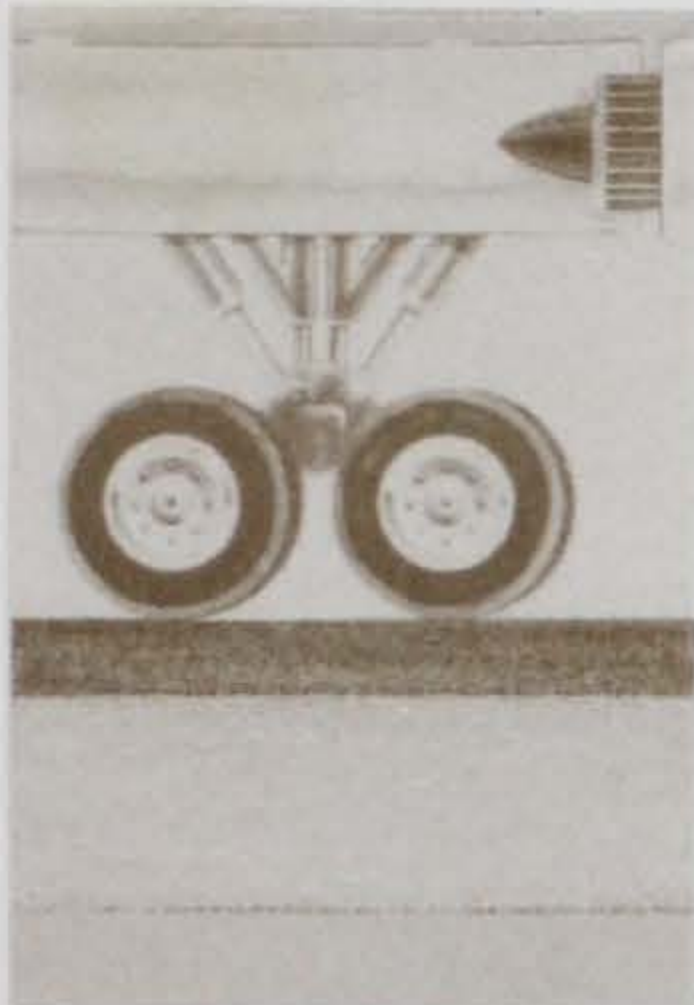

September 1992

Final Report

Approved For Public Release; Distribution Is Unlimited

RESEARCH LIBRARY  
US ARMY ENGINEER WATERWAYS  
EXPERIMENT STATION  
VICKSBURG, MISSISSIPPI



Prepared for DEPARTMENT OF THE ARMY  
US Army Corps of Engineers  
Washington, DC 20314-1000

2685-9841

TA4  
W34m  
no. GL-92-32

REPORT DOCUMENTATION PAGE			Form Approved <i>C.3</i> OMB No. 0704-0188		
Public reporting burden for this collection of information is estimated to average 1 hour per response, including the time for reviewing instructions, searching existing data sources, gathering and maintaining the data needed, and completing and reviewing the collection of information. Send comments regarding this burden estimate or any other aspect of this collection of information, including suggestions for reducing this burden, to Washington Headquarters Services, Directorate for Information Operations and Reports, 1215 Jefferson Davis Highway, Suite 1204, Arlington, VA 22202-4302, and to the Office of Management and Budget, Paperwork Reduction Project (0704-0188), Washington, DC 20503.					
1. AGENCY USE ONLY (Leave blank)		2. REPORT DATE September 1992	3. REPORT TYPE AND DATES COVERED Final report		
4. TITLE AND SUBTITLE Reanalysis of Multiple-Wheel Landing Gear Traffic Tests			5. FUNDING NUMBERS		
6. AUTHOR(S) Richard Ahlvin, Jim W. Hall, Jr.					
7. PERFORMING ORGANIZATION NAME(S) AND ADDRESS(ES) USAE Waterways Experiment Station Geotechnical Laboratory 3909 Halls Ferry Road Vicksburg, MS 39180-6199			8. PERFORMING ORGANIZATION REPORT NUMBER		
9. SPONSORING/MONITORING AGENCY NAME(S) AND ADDRESS(ES) US Army Corps of Engineers Washington, DC 20314-1000			10. SPONSORING/MONITORING AGENCY REPORT NUMBER Miscellaneous Paper GL-92-32		
11. SUPPLEMENTARY NOTES Available from National Technical Information Service, 5285 Port Royal Road, Springfield, VA 22161					
12a. DISTRIBUTION/AVAILABILITY STATEMENT Approved for public release; distribution is unlimited			12b. DISTRIBUTION CODE		
13. ABSTRACT (Maximum 200 words) Growth of aircraft to over a million pounds, with the need for many wheels to support such aircraft, has focused attention on the unduly conservative aspect of present equivalent single wheel load (ESWL) methods when applied to many grouped wheels. The assembly of all multiple-wheel accelerated traffic test data for use in reexamining ESWL methods provided an indication that the earliest multiple-wheel tests likely were treated extremely conservatively during their analysis some 40 years ago. Accordingly, these early tests (reported in TM 3-349) were subjected to a reexamination. The reexamination confirmed that the initial analysis was quite conservatively carried out. With the benefit of the added 40 years of research findings and experience with in-service pavements a less conservative analysis can now be made and accepted with confidence. This report presents the reanalysis carried out and the revised pavement behavior indicated.					
14. SUBJECT TERMS Aircraft loads Design criteria Distress failure Flexible pavement Pavements Performance data			15. NUMBER OF PAGES 35		
			16. PRICE CODE		
17. SECURITY CLASSIFICATION OF REPORT Unclassified	18. SECURITY CLASSIFICATION OF THIS PAGE Unclassified	19. SECURITY CLASSIFICATION OF ABSTRACT Unclassified	20. LIMITATION OF ABSTRACT		

## Preface

This report is an element of the larger study (identify the million pound aircraft/ESWL study here). Its pertinence and desirability was recognized in pursuing the larger study. While this is a relatively small work, its significance to the overall analysis is potentially great. This analysis was carried out by WES consultant, R. G. Ahlvin, under guidance and review of Dr. Walter Barker, Project Leader for this study, Pavement Systems Division (PSD), Geotechnical Laboratory (GL) Mr. Jim W. Hall, Jr., Chief, Systems Analysis Branch, PSD, and Dr. George Hammitt II, Chief, PSD. This report was written by Messrs. Ahlvin and Hall. Dr. W. F. Marcuson III was Director of GL during the conduct of this work.

At the time of publication of this report, Director of WES was Dr. Robert W. Whalin. Commander and Deputy Director was COL Leonard G. Hassell, EN.

## Contents

	<u>Page</u>
Preface.....	1
Conversion Factors, Non-SI to SI (Metric)	
Units of Measurement.....	3
Background.....	4
Purpose.....	6
Scope.....	6
Test Elements.....	7
Evaluation Based on Visual Observation.....	9
Effective Strength of Test Units.....	10
Unit Strength Reassessments.....	13
Unit 1-150 Kip, B-36 load.....	13
Unit 2-150 Kip, B-36 load.....	13
Unit 3-150 Kip, B-36 load.....	13
Unit 1-200 Kip, B-36 load.....	14
Unit 2-200 Kip, B-36 load.....	14
Unit 3-200 Kip, B-36 load.....	14
Unit 4-70 Kip, B-29 load.....	14
Unit 5-70 Kip, B-29 load.....	15
Unit 6-70 Kip, B-29 load.....	15
Unit 4-100 Kip, B-50 load.....	15
Unit 5-100 Kip, B-50 load.....	15
Unit 6-100 Kip, B-50 load.....	16
Combined Load Repetitions.....	16
Summary of Critical Determinations from Reassessment.....	18
Indicated Pavement Behavior.....	18
Tables 1-2	
Figure 1-6	

Conversion Factors, Non-SI to SI (Metric)

Units of Measurement

Non-SI units of measurement used in this report can be converted to SI (metric) units as follows:

<u>Multiply</u>	<u>By</u>	<u>To Obtain</u>
feet	0.3048	metres
inches	2.54	centimetres
kips (force)	4.448222	kilonewtons
pounds (force)	4.448222	newtons
pounds (force) per square inch	6.894757	kilopascals
pounds (mass)	0.4535924	kilograms
pounds (mass) per cubic foot	16.01846	kilograms per cubic metre
square inches	6.4516	square centimetres

## REANALYSIS OF MULTIPLE-WHEEL LANDING GEAR TRAFFIC TESTS

### Background

1. As the B-17 and B-24 bomber aircraft of WW-II were supplanted by the much heavier B-29 and B-36 bombers, it became necessary to support the larger aircraft on more than single-wheel main landing gear. The B-29 accordingly was supported on main gear struts having dual wheels. Later the term twin became preferred. The B-36 had four wheels per strut called dual-tandem which is later referred to as twin-tandem.

2. It was necessary to use existing single-wheel design criteria for these new, multiple-wheel landing gear aircraft, and the equivalent single wheel load (ESWL) was devised as a means of doing this. The ESWL is defined as a single-wheel load which requires the same pavement structure for support as would the multiple-wheel (dual or dual-tandem at the time) of concern. As such, it represents the combined or overlapping requirements of the two or four (or more) wheels of multiple-wheel configurations. Since effects of overlapping depend on depth below the surface, as well as wheel spacing, the ESWL is not a single value but varies with total pavement structure thickness.

3. A method for establishing the ESWL for any dual or dual-tandem gear configuration was devised using available data and knowledge and reasonable geometric patterns. This method is recognized as the  $d/2$  and  $2S$  method. Figure 1 shows the definition of  $d$  and  $s$ . For this, the ESWL is the single-wheel load at depths less than  $d/2$ , where  $d$  is the distance between the edges of the two closest tire prints of a gear. ESWL is the total gear load on one of its wheels at depths greater than  $2S$ , where  $S$  is the center-to-center distance between dual wheels or the diagonal distance between centers for dual-tandem. Between these two depths, the ESWL was represented by a straight line on a plot of logarithm of load versus logarithm of depth as shown in Figure 2.

4. Full scale accelerated traffic tests were undertaken in late 1948 to assess the validity of the ESWL method and design criteria based on ESWL and

established single-wheel criteria. The tests were performed during 1949 and 1950 and reported as TM 3-349.\*

5. Test analysis concluded that the  $d/2$ , 2S method for ESWL determination, while close, was somewhat unconservative. This led to a further analysis, which resulted in the method continuing in use to the present. The newer method establishes the ESWL on the basis of equal maximum theoretical vertical deflections (at any depth) calculated using a single-layer or half-space elastic (Boussinesq) model.

6. This ESWL method led to pavement design criteria in better agreement with the traffic test findings as reported in TM 3-349.

7. The reanalysis, which led to ESWL methodology based on theoretical deflections for a single layer model, recognized that the pattern for computed deflections, as compared to those measured in the stress-distribution studies, at wider offsets from the load center did not reduce to zero as did measured values. This implied that the contribution of wheels at wide offset spacing to the collective ESWL evaluation would likely be larger than actual and therefore conservative. Since relative magnitudes are small at wider offsets, this was not a serious concern for two and four wheel landing gear loads. It does, however, become significant, and likely seriously so, for many-wheel landing gear systems. This discrepancy is illustrated in Figure 3.

8. This aspect of load support has become a matter of serious concern in relation to landing gear design for aircraft which will weigh in excess of a million pounds. The many wheels which will be required to support the heavier aircraft and not seriously overload airfield pavements capable of supporting present wide-body aircraft is the concern. Requirement for more support wheels than appears reasonable makes reduction of the probable conservatism in the present ESWL methods a necessity.

9. In response to this problem, both vastly improved analytical models with their supporting computer capabilities and all applicable prototype traffic test data are being examined or reexamined toward improving ESWL and multiple-wheel pavement design methods.

---

\* Headquarters, Department of the Army. 1952 (Sep). "Design of Flexible Airfield Pavements for Multiple-Wheel Land Gear Assemblies, Report No. 1 Test Section with Lean-Clay Subgrade," Technical Manual TM 3-349, Washington, DC.

10. The collective reexamination of test pavement behavior results applicable to multiple-wheel aircraft support introduced a question relative to the analysis reported for the first multiple-wheel tests. The B-29, B-36, and B-50 traffic test behavior from these earliest tests did not appear to be of quite the same pattern as that of later findings involving the B-47, B-52, heavier twin-tandem, C-5, and a Boeing 747 gear element.

11. Brief restudy of the analysis reported in TM 3-349, for the first multiple-wheel tests, and with the benefit of much better experience and hindsight, appear to indicate a much more conservative analysis of the early data than necessary.

#### Purpose

12. The purpose of this study was to reexamine the analysis reported in TM 3-349, the first multiple-wheel traffic tests on flexible pavements. The aim is an evaluation of effective subgrade strength in the units of the test section and of the cumulative traffic applied, which better reflects improvement in knowledge and methods during the 40 years since the tests were conducted.

#### Scope

13. The first full scale traffic tests to assess the capability of flexible pavements to support dual and dual-tandem aircraft loads were conducted over 40 years ago. These multiple-wheel loads involved new and unknown factors. The medium strength test subgrade, using the local lean-clay at the US Army Engineer Waterways Experiment Station (WES), was being employed for the first time in traffic tests. The ongoing military involvement and potential military applications dictated a need for pavement design criteria which could be depended on to provide satisfactory pavements.

14. In these circumstances it is not surprising that determinations, interpreted from less than strongly consistent data patterns, were made conservatively. It was deemed necessary to arrive at design criteria for pavements which would surely serve their purpose.



15. Now, with the advantage of an additional 40 years of pavement technology developments, it is possible to reinterpret the data collected for the first multiple-wheel tests and reported in TM 3-323.\* This reinterpretation will arrive, with confidence, at more representative determinations for characterizing the behavior exhibited by the pavement tests.

16. Thus, this study will reestablish the rated effective strength, the CBR considered pertinent, of the various test section units which were effective during traffic testing.

17. In 1949 and 1950, when the multiple-wheel flexible pavement tests were performed, the roll of stress repetitions (or coverages), as it is now recognized, had not yet become understood. It was then considered that about 2,000 coverages of test traffic would establish the capability of a pavement to support such traffic for 5,000 coverages and more. It is now recognized that all traffic on a pavement needs to be combined to arrive at the combination of load and repetitions pertinent to load support capacity.

18. This study will also evaluate the combined effective test traffic, coverages of load plus prior, lower load, traffic in terms of equivalent coverages of (the larger) load, for the test units first tested using the "design" load then further tested using a larger load.

#### Test Elements

19. Greater detail of the multiple-wheel pavement tests can be found in TM 3-349, but elements of concern to this reassessment effort will be included here.

20. Tests were planned for a 70,000 lb\*\* B-29 dual-wheel gear load and a 150,000 lb B-36 dual-tandem gear load. The test section consisted of a B-29 lane and a B-36 lane. Each lane included three units, numbered 1, 2, 3 for the B-36 lane and 4, 5, 6 for the B-29 lane. Units 1 and 4 were an under design, units 2 and 5 were at design thickness, and units 3 and 6 were an over design. Thicknesses for the six units were as follows:

---

\* US Army Engineer Waterways Experiment Station. 1951 (Mar). "Investigation of Pressures and Deflections for Flexible Pavements, Report No. 1, Homogeneous Clayey-Silt Test Section," TM 3-323, Vicksburg, MS.

\*\* A table of factors for converting non-SI units of measurement to SI (metric) units is presented on page 3.

<u>Lane</u>	<u>Unit</u>	<u>Thickness of Structure</u>	<u>Surface</u>	+	<u>Base</u>
B-36	1	14 in.	3 in.		11 in.
	2	20 in.	3 in.		17 in.
	3	26 in.	3 in.		23 in.
B-29	4	10 in.	3 in.		7 in.
(B-50)	5	15 in.	3 in.		12 in.
	6	20 in.	3 in.		17 in.

Figure 4\* shows the layout and cross sections of the test lanes.

21. Two thousand coverages of test load traffic were applied to the test lanes with B-29 and B-36 gear as planned. Subsequently, an additional 2,000 coverages of increased load, 100,000 lb B-50 dual and 200,000 lb B-36 dual-tandem, traffic was programmed for the same two test lanes. With two exceptions involving early failures, this increased load traffic was applied to the test section.

22. Characteristics of the test landing gear loads were:

<u>Gear Type</u>	<u>Load, kips</u>	<u>Tire Press psi</u>	<u>Contact Area in.<sup>2</sup></u>	<u>Wheel Spacing c-c, in.</u>
B-36 dual-tandem	150	140	260	31 x 60
B-29 dual	70	100	328	37 1/2
B-36 dual-tandem	200	198	273	31 x 60
B-50 dual	100	190	258	37 1/2

23. The test section subgrade was a lean clay, CL, with LL = 36, PI = 13, constructed to 108 lb/cu ft dry density at a moisture content of (about) 17.5 percent. The average CBR for the in-place subgrade before traffic was 18 percent (reported in the base report, TM 3-349).

24. Extensive deflection measurements were made under a variety of static loads. From these, an average modulus of elasticity ( $E_m$ ) was back-calculated using the following formula for deflection under the center of the loaded circular area which relates to a single layer elastic model.

$$w = \frac{3P}{2\pi E_m \sqrt{z^2 + r^2}}$$

\* Plate 1 from TM 3-349.

where:

- P = load, lb
- w = deflection in inches at depth z
- E<sub>m</sub> = modulus of elasticity in psi
- z = depth in inches
- r = radius of (circular) contact area

These were reported in TM 3-349 as:

Average Values of Modulus of Elasticity

<u>Unit</u>	<u>Depth z in.</u>	<u>Average E<sub>m</sub> psi</u>
1	14	8,400
2	20	9,600
3	26	8,800
4	10	6,700
5	15	8,450
6	20	8,200

Figure 5\* shows the locations of deflection measurements and of test pits in the six test units.

25. Soil test data, including the subgrade CBR test results of particular interest for this reassessment, are shown in Table 1\*\*. Table 2† lists observations of the tested units under traffic. This shows, in relation to coverage levels, the observable effects of traffic and opening of test pits for collection of CBR and other soil test information.

26. The table summarizing behavior of all load tests by loading, unit, and thickness as it appears in TM 3-345 is as follows:

Evaluation Based on Visual Observation

<u>Assembly Load, lb</u>	<u>Unit</u>	<u>Thickness in.</u>	<u>Area Evaluated</u>	<u>Pertinent CBR Percent</u>	<u>Indicated Pavement Behavior</u>
150,000	1	14	South 7 ft of unit	20	Inadequate
			Remainder of unit	32	Adequate
	2	20	Entire unit	29	Adequate
	3	26	Entire unit	22	Adequate

\* Plate 7 from TM 3-349.

\*\* Table 2 from TM 3-349.

† Table 4 from TM 3-349.

<u>Assembly Load, lb</u>	<u>Unit</u>	<u>Thickness in.</u>	<u>Area Evaluated</u>	<u>Pertinent CBR Percent</u>	<u>Indicated Pavement Behavior</u>
200,000	1	14	Entire unit	25*	Inadequate
	2	20	Entire unit	27	Borderline
	3	26	Entire unit	20	Adequate
70,000	4	10	South 6 ft of unit	27	Inadequate
			Remainder of unit	35	Borderline
	5	15	Entire unit	25	Adequate
	6	20	Entire	20	Adequate
100,000	4	10	Entire unit	50*	Inadequate
	5	15	Entire unit	24	Borderline
	6	20	except south 4 ft Entire unit	30	Adequate

The strength (CBR) data in this table are the primary concern of this reassessment. The evaluation determinations are for traffic of 2,000 coverages. The determinations are for actual applied traffic in all but the two cases indicated. One of these, Unit 1 under 200,000 lb B-36 traffic, failed after 610 coverages. The CBR was rated 18 and was adjusted to 25 in., an attempt to represent a subgrade strength which would have led to failure at 2,000 coverages. Figure 6\*\* shows the adjustment process. The second case of early failure, Unit 4 under 100,000 lb B-50 traffic, was considered failed at 328 coverages. The CBR was rated 35 and was adjusted to 50 to represent a 2,000 coverage inadequate behavior. Figure 6 also shows this adjustment.

#### Effective Strength of Test Units

27. The table from TM 3-349 summarizing behavior of the six test units, each subject to two load magnitudes, shows unit strengths ranging up to 50 CBR and averaging 27.6 CBR. Since this appears quite high in relation to the average CBR of 18 for the in-place subgrade before traffic, as reported in TM 3-349†, it was suspected that the rated strengths, CBR values, were likely very conservatively selected. Accordingly, the individual CBR measurements

---

\* Value adjusted to 2,000 coverages.

\*\* Plate 16 from TM 3-349.

† TM 3-349 paragraph 5, page 4.

and other related information reported were carefully reexamined, with the benefit of an additional 40 years of experience with pavement behavior under heavy aircraft and with research analysis.

28. Table 1 shows the subgrade CBR measurements separated as to the top 2 in. of subgrade and to 4 in. or more below subgrade surface. Each of these is separated into inside and outside the tracking lane. From these data the following subgrade average CBR values have been derived:

Average CBR Values

<u>Basis</u>	<u>Average CBR</u>
All recorded values	20.3
All values before any traffic	16.1
All values outside the traffic lane	18.3
Top 2 in. outside the traffic lane, all values	20.5
All values inside the traffic lane	21.1
Top 2 in. inside the traffic lane, all values	23.8
All values outside the traffic lane during Sep, Oct, Nov 1949	18.0
All values outside the traffic lane during Apr, May 1950	20.0

Average CBR Values by Units

<u>Basis</u>	<u>Unit 1</u>	<u>Unit 2</u>	<u>Unit 3</u>	<u>Unit 4</u>	<u>Unit 5</u>	<u>Unit 6</u>
All recorded values	20.2	22.3	19.7	21.6	17.9	19.3
All values outside the traffic lane	17.5	19.0	18.8	21.0	14.0	15.5
All values inside the traffic lane	21.1	23.8	20.1	21.7	19.2	21.2
All top 2-in. values inside traffic lane	23.7	26.0	22.0	24.6	21.6	25.0
All 4 in. and below values inside traffic lane	15.8	19.3	17.0	18.0	15.3	17.5
All values for the lower load magnitude*	20.9	20.2	21.6	21.2	16.4	17.5
All values for the higher load magnitude*	22.5	24.5	19.5	22.0	19.2	21.3
All values in the weak first 5 to 10 ft	18.0	--	--	20.5	--	--

29. These various average CBR values strongly suggest that the original analysis adopted CBR ratings which by present means and knowledge are unduly conservative.

---

\* See paragraph 21.

30. A further strong indication that the original analysis can now be considered unduly conservative is shown by the modulus of elasticity,  $E_m$ , values from TM 3-349 (page 29) and presented earlier under "Test Elements." These were determined from measured subgrade deflections assuming single layer elastic behavior to be applicable. While this assumption can be questionable, the values resulting cannot be considered grossly in error. Also, their consistency or variation among units would not be significantly different were they determined using a more applicable model or theory.

31. Other studies have indicated a consistent relation between modulus of elasticity and CBR for any particular site or test series. The relation has been reported as tending to be:  $CBR \times 1,500 = E_m$ , where  $E_m$  is in psi. The 1,500 value, however, tends to represent a small strain or tangent modulus and has been found to deviate to smaller and larger values at different sites or test series.

32. If the 1,500 x CBR is simplistically applied to the  $E_m$  values reported; i. e.  $E_m/1,500$ , the CBR values resulting are much lower than those used in the TM 3-349 analysis and earlier listed herein. If the average of all recorded CBR values (20.3) is related to the average of all  $E_m$  values reported, (8,358 psi) the resulting ratio is 412.\* That is:

$$CBR = \frac{E_m}{412}$$

Extending the CBR values for the six test units using this relation shows the following.

CBR Values Derived from  $E_m$  Values

<u>Unit</u>	<u><math>E_m</math> Value</u>	<u>Derived CBR</u>
1	8,400 psi	20.4
2	9,600 psi	23.3
3	8,800 psi	21.4
4	6,700 psi	16.3
5	8,450 psi	20.5
6	8,200 psi	19.9

---

\* Note: This difference from the 1,500 ratio is not surprising since it not only represents a secant (larger strain) modulus, but is also for assumed conditions known not to be satisfied here.

33. All of these reassessment examinations, along with the understanding that the test subgrades were constructed to a uniform strength, argue that the effective subgrade strength for all test units can be considered to be represented by CBR values in the low 20s or less.

#### Unit Strength Reassessments

34. Reexaminations of the representative subgrade CBR values for each unit, or diverging part, and under each load being applied are discussed unit by unit in the following paragraphs.

##### Unit 1 - 150 kip, B-36 load

35. The first 7 ft of this unit was reported at 20 CBR after 510 coverages and 16 after 1,000 coverages. These are the top 2-in. values measured within the traffic lane. The conservative 20 CBR was selected to rate the behavior. It is noted that the 0 coverage strength is reported as 18 CBR so that the three values average 18. Also, the average of all measurements from test pits 22, 23, and 27 (those in the first 7 ft of the unit) is also 18 CBR. For the first 7 ft of Unit 1, a rating of 18 CBR is considered proper. This section is considered "inadequate" at 2,000 coverages.

36. The remainder of Unit 1 was rated 32 CBR based on the top 2-in. values in the traffic lane (30 and 34). However, considering also the 4 in. and more values and the 0 coverage values the average CBR is only 21.5. The array of average CBR values from the earlier listing of average values by units also argues for a much lower value. A rating of 22 CBR is considered proper here, and this portion of Unit 1 is considered "adequate."

##### Unit 2 - 150 kip, B-36 load

37. The unit was rated 29 CBR based on the single reported 2,000 coverage value measured in the top 2 in. However, testing began at a 0 coverage, 15 CBR, and the 2,000 coverage value at below 4 in. was 17. Practice beyond the 1950 period of these tests came to make use of average CBR in the top 6 in. Based on the average of 2 in. and below 4-in. values and the average values earlier listed, a rating of 23 CBR is considered proper. The section is considered "adequate."

##### Unit 3 - 150 kip, B-36 load

38. The 22 CBR rating for this unit was based on the average of all 2-in. readings in the traffic lane, but an average of all determinations for

this unit and load is 21.6; so the 22 CBR is considered proper. The section is considered "adequate."

Unit 1 - 200 kip, B-36 load

39. This unit had a subgrade CBR of 18 after 460 coverages and was considered failed after 610 coverages. The 18 value was adopted as a strength rating but the CBR was adjusted to 25 to represent failure at 2,000 coverages. More consistent with the pattern of average CBR values is a rating of 20 CBR, but the adjustment to 2,000 coverages is not now considered correct. The unit is considered properly rated at 20 CBR, and the section is considered "inadequate." See the later discussion of combined coverages for adjustment from failure at 610.

Unit 2 - 200 kip, B-36 load

40. The unit measured 26 CBR after 1,056 coverages and measured 31 and 26 (presented as 28) after 2,000 coverages. These measurements were all at 2 in. and in the traffic lane. The unit was rated a 27. This is indicated to be the strongest unit by the analyses of modulus of elasticity values based on measured deflections. Based on this and the average CBR values reported for Unit 2, the unit is considered to be properly rated 24 CBR. Unit 2 under this load is considered "borderline" at 2,000 coverages.

Unit 3 - 200 kip, B-36 load

41. The subgrade CBR was 19 for this unit after 1,056 coverages and 22 after 2,000 coverages. The rating was 20 CBR based on readings at 2 in. depth in the traffic lane of 19 (1,056 coverages) and of 23 and 21 (2,000 coverages). This rating is consistent with the CBR averages presented earlier and 20 CBR is considered a proper rating for the unit. Performance is considered "adequate."

Unit 4 - 70 kip, B-29 load

42. The single CBR determination of 27 for the top 2 in. of subgrade and in the traffic lane was taken as the rating for the weaker first 6 ft of this unit. Using all values from test pits 3 and 4, which were in the first 6 ft, an average CBR of only 20.4 is computed, and if the 0 coverage values for the unit are included, the average is only 19.4. The modulus of elasticity from deflection measurements indicate this to be the weakest unit, but the CBR averages show it to be one of the stronger units. It is considered that a CBR of 21 is a proper rating for this part of Unit 4. It is considered to reflect "inadequate" behavior.



43. The remainder of Unit 4 was rated 35 on the basis of the highest CBR found after 2,000 coverages. The CBR averages listed can justify a value no higher than 24. Thus, 24 CBR is considered proper, and performance is "borderline."

Unit 5 - 70 kip, B-29 load

44. This unit was rated 25 CBR based on a single determination at 2 in. in the traffic lane. The 0 coverage reading was only 16, the average of all readings was only 16.4, and the average of all readings in the traffic lane was only 18. A CBR of 19 is considered a proper rating for the unit. Its behavior is considered "adequate."

Unit 6 - 70 kip, B-29 load

45. The unit is rated by a single value of 20 CBR at 2,000 coverages and for 2 in. subgrade depth inside the traffic lane. The CBR averages indicate this to be a weaker one of the six units. All values average 19.3 and all values for this load is only 17.5. A rating of 19 is considered proper for Unit 6, and its performance is considered "adequate."

Unit 4 - 100 kip, B-50 load

46. This unit was rated 35 CBR based on a single, 2 in., in-lane value at the beginning of testing. An in-lane, 2-in. rating of only 11 at 250 coverages was considered to reflect disruptive deterioration and not used for the rating. The low value (11) however, was measured near the deflection gage which also showed larger deflections and the low modulus value indicating Unit 4 to be weaker than others. The average of all CBR determinations from the end of earlier traffic application to failure of this unit at 328 coverages is only 22. A rating of 23 CBR is considered proper for this unit, and performance is "inadequate." The 35 CBR rating at 328 coverages was "adjusted" to 50 CBR to represent 2,000 coverage behavior, but this adjustment is no longer considered proper. A reassessment of combined coverages will apply.

Unit 5 - 100 kip, B-50 load

47. The first 4 ft of this unit showed failure at 750 coverages. The failure had progressed from the adjacent unit and was not considered applicable, but it is now considered pertinent. Both a direct measurement at 2 in. in the traffic lane and the average of all determinations for pits 11 and 12 were 18 CBR. The 18 CBR is thus pertinent but pits 11 and 12 are beyond the first 4 ft. It follows that the weaker section is somewhat weaker, and a

value of 17 CBR is considered pertinent. This part of Unit 5 is considered "inadequate" at 750 coverages.

48. The main part of Unit 5 is rated 24 CBR based on a 750 coverage and a 2,000 coverage rating (26 and 23) for the top 2 in. and in the traffic lane. The CBR averages listed earlier show that Unit 5 is the weakest of the six units. Average of all values is only 17.9, and average of all values for the 100-kip loading is 19.2. A rating of 19 CBR is considered proper for Unit 5, and its performance is "borderline."

#### Unit 6 - 100 kip, B-50 load

49. The unit was rated a 30 CBR based on a single 2-in. in-lane determination at 2,000 coverages. However, the average of all Unit 6 determinations is only 19.3 and of all determinations for the 100 kip loading is 21.3 CBR. A rating of 21 CBR is considered proper and the unit behavior is considered "adequate."

#### Combined Load Repetitions

50. When the first multiple-wheel accelerated traffic tests were conducted, the roll of load repetitions, along with load magnitude, in determining pavement use-life was not well understood. It was then considered that showing a pavement to be capable of sustaining substantial would establish its capability to continue to carry the load. "Substantial load repetitions" were represented then by 2,000 coverages. The initial application of lower load repetitions (to 2,000 coverages) was not then considered contributory to performance under subsequent application of a substantially heavier load.

51. It is now considered that load magnitude and load repetitions are completely and continuously interrelated. It follows that the initial 150-kip B-36 and 70-kip B-29 loadings contributed to the cumulative repetitions of the 200-kip B-36 and 100-kip B-50 test traffic applied.

52. No single means for determining the equivalent coverages of the second and larger load applied, which is represented by the smaller load traffic in the same lane, is applicable. Differences in subgrade strength, thickness, ESWL methods, and variations in behavior concepts from 1950 to the present all legislate against a single methodology and unique result. This problem, however, does not prevent arriving at a useful determination. The variations in methods and input parameters lead to variation in results

determined, but this variation has no great significance. Because the correlation trend is between the logarithm of coverages and ratio to full design thickness, the coverage determination does not need to be precise. Accordingly, only nominal means are needed.

53. For nominal determination, we can begin with design thickness for the B-29 and lower B-36 loads, determine equivalent design thickness for the higher B-50 and B-36 loads, and use the ratio to indicate equivalent coverages as shown below.

<u>Design Thickness</u>	<u>Equivalent Thickness for Larger Load</u>	<u>Ratio</u>	<u>Equivalent Coverages*</u>
70 kip, B-29 = 15"	100 kip, B-50 = 18.5"	0.81	747
150 kip, B-36 = 20"	200 kip, B-36 = 24.0"	0.83	905

54. To provide some perspective for these "nominal" results, the equivalent coverages can be determined by the FAA\*\* equation provided for air-field design use:

$$\log R_1 = \log R_2 \left( \frac{W_2}{W_1} \right)^{1/2}$$

where

R = repetitions

W = assembly load

For the B-29 test lane this gives:

$$\log R_1 = \log 2,000 \left( \frac{70}{100} \right)^{1/2}, \text{ from which } R_1 = 580 \text{ coverages}$$

---

\* Equivalent coverages of the larger load represented by full design coverages of the lower load can be determined from either the  $0.23 \log C + 0.15$  = ratio or the equivalent plot of percent design thickness versus coverages.

\*\* FAA Advisory Circular, AC 150/5320-6C

For the B-36 test lane this gives:

$$\log R_1 = \log 2,000 \left( \frac{150}{200} \right)^{1/2}, \text{ from which } R_1 = 723 \text{ coverages}$$

55. Based on these determinations, it is considered that the lower load test traffic can be satisfactorily represented as equivalent coverages of the higher load test traffic as follows:

<u>Test Lane</u>	<u>Equivalent Coverages of Higher Load Traffic due to Lower Load Traffic</u>
B-29	650 coverages
B-36	800 coverages

Summary of Critical Determinations from Reassessment

56. This reassessment analysis verifies the recongnized probability that the analysis originally reported for the first multiple-wheel traffic tests represents unduly conservative determinations in relation to more current concepts and cumulated knowledge since the report of testing. A summary of the revised determinations applicable to current multiple-wheel concerns is as follows:

Indicated Pavement Behavior

<u>Assembly Load, lb</u>	<u>Unit</u>	<u>Thickness in.</u>	<u>Area Evaluated</u>	<u>Pertinent CBR Percent</u>	<u>Coverages</u>	<u>Evaluation</u>	
150,000	1	14	South 7 ft of unit	18	2,000	Inadequate	
			Remainder of unit	22	2,000	Adequate	
	[B-36] [Gear]	2 3	20 26	Entire unit	23	2,000	Adequate
				Entire unit	22	2,000	Adequate
200,000	1	14	Entire unit	20	1,410	Inadequate	
	[B-36] [Gear]	2 3	20 26	Entire unit	24	2,800	Borderline
				Entire unit	20	2,800	Adequate
70,000	4	10	South 6 ft of unit	21	2,000	Inadequate	
			Remainder of unit	24	2,000	Borderline	

(Continued)

<u>Assembly Load, lb</u>	<u>Unit</u>	<u>Thickness in.</u>	<u>Area Evaluated</u>	<u>Pertinent CBR Percent</u>	<u>Coverages</u>	<u>Evaluation</u>
[B-29]	5	15	Entire unit	19	2,000	Adequate
[Gear]	6	20	Entire	19	2,000	Adequate
100,000	4	10	Entire unit	23	978	Inadequate
[B-50]	5	15	Entire unit except south 4 ft	19	2,650	Borderline
[Gear]	6	20	Entire unit	17	1,400	Inadequate
				21	2,650	Adequate

57. These data appear to represent better the behavior of the flexible pavements subjected to accelerated traffic of B-29, B-50, and B-36 landing gear loadings in the first multiple-wheel tests conducted in 1949 and 1950. It is, thus, recommended that these data be used in lieu of the data as reported in TM 3-349 for any analysis or method development relative to multiple-wheel design criteria or to ESWL determination methods.

Table 1  
Soil Test Data

Unit	Base Course			Test Pit No.	Average Moisture Percent	Average Density lb/cu ft	In-Place CBR Percent		Average Moisture Percent	Average Density lb/cu ft	Subgrade				Coverages						
	Thickness, in.						Inside Trafficked Area	Outside Trafficked Area			In Place CBR Percent		At Points in Top 2 in. of Subgrade		At Points 4 in. or More Below Surface of Subgrade		With B-36 Assembly Loaded to 150,000 lb	With B-36 Assembly Loaded to 200,000 lb	With B-29 Assembly Loaded to 70,000 lb	With B-50 Assembly Loaded to 100,000 lb	
	Wearing Course	Base Course	Total								Inside Trafficked Area	Outside Trafficked Area	Inside Trafficked Area	Outside Trafficked Area	Inside Trafficked Area	Outside Trafficked Area					
1	3	11	14	20					15.4	117			18					0			
				20					17.9	108											
				21			150+														
				22			79					114								510	
				22							17.6	111	20		11						
				23								114	16							1,000	
				23								114		24							
				23								110			17						
				23								111				16					
				23						140	136										
				24				0.8	146	147+			114	30							
				24									110			20					
				26						150+		15.4	115	34							2,000
				26								18.2	109			15					
27					2.1	143	120	16.8	116	22							0				
28					1.0		119	15.9	115	37											
29					1.1		90	16.1	116	18							460				
30					1.2		62	15.8	117	13							610				
2	3	17	20	31				15.3	116	15								0			
				31				15.5	116		15										
				31				17.5	107						15						
				32			150+														
				33			150+				15.8	115	29							2,000	
				33							17.9	110			17						
				34				1.3	137	150+	15.6	116	30							0	
				35				1.3		150+	17.5	113	26								1,056
				36				1.2		144	15.3	115	31								2,000
				36							16.5	112		28							
				36							17.1	109				18					
36							17.6	110			20										
37					0.9		148	16.0	114	25											
37								18.1	108			21									

(Continued)

Table 1 (Continued)

Unit	Base Course			Test Pit No.	Average Moisture Percent	Average Density lb/cu ft	Subgrade								Coverages						
	Wearing Course	Base Course	Total				In-Place CBR Percent		Average Moisture Percent	Average Density lb/cu ft	In Place CBR Percent				With B-36 Assembly Loaded to 150,000 lb	With B-36 Assembly Loaded to 200,000 lb	With B-29 Assembly Loaded to 70,000 lb	With B-50 Assembly Loaded to 100,000 lb			
							Inside Trafficked Area	Outside Trafficked Area			At Points in Top 2 in. of Subgrade		At Points 4 in. or More Below Surface of Subgrade								
											Inside Trafficked Area	Outside Trafficked Area	Inside Trafficked Area	Outside Trafficked Area							
3	3	23	26	38			16.6	106			21			0							
				38			16.4	114					20								
				39				122													
				40				150+		16.5	114	22				2,000					
				40						17.4	108			20							
				41			4.6	143	137+	16.0	114	25					0				
				42			1.0		90	16.4	114	19					1,056				
				43			1.3			16.3	113	23					2,000				
				43			1.3		84	75	17.3	113		19							
				43							17.9	106			14						
				43							17.9	104			15						
				44			1.0		130+		16.9	112	21								
				44							18.2	111			17						
				4	3	7	10	1			16.9	109			19						
1			17.5					110					15								
2								86													
3								61		15.9	113	27								1,500	
3										17.3	111			19							
4			1.3					144	46	14.5	117	15								2,000	
4			1.1					143		15.7	114		28								
4										17.0	115			13							
4										17.1	113				21						
5			1.2					140	76	16.0	112	35									
5										17.0	110			22							
6									146	92	16.1	111	35			26					0
6											17.0	109									
7									35		16.0	113	11			14					250
7							16.7	112													

(Continued)

Table 1 (Concluded)

Unit	Base Course			Subgrade										Coverages								
	Thickness, in.			Test Pit No.	Average Moisture Percent	Average Density lb/cu ft	In-Place CBR Percent		Average Moisture Percent	Average Density lb/cu ft	In Place CBR Percent		Inside Trafficked Area	Outside Trafficked Area	Inside Trafficked Area	Outside Trafficked Area	With B-36 Assembly Loaded to 150,000 lb	With B-36 Assembly Loaded to 200,000 lb	With B-29 Assembly Loaded to 70,000 lb	With B-50 Assembly Loaded to 100,000 lb		
	Wearing Course	Base Course	Total				Inside Trafficked Area	Outside Trafficked Area			At Points in Top 2 in. of Subgrade	At Points 4 in. or More Below Surface of Subgrade										
											Inside Trafficked Area	Outside Trafficked Area									Inside Trafficked Area	Outside Trafficked Area
5	3	12	15	8					16.0	114	16								0			
				8					16.4	115		14										
				8					17.3	110					14							
				9				86														
				10				105														
				11							16.4	114	25							2,000		0
				11				1.1	141	104	18.5	104				13						
				12						96	16.3	115	18									
				12							18.7	111				14						750
				13						150+	16.4	113	26									
				13							18.5	108				16						
				14						150+	16.6	114	23									2,000
				14							19.0	110				18						
				6	3	17	20	15					17.0	111								
15									17.6	107				18								
16									71													
17									128													
18									137	142+	17.2	111	20						2,000		0	
18											17.8	112				19						
19										150+	17.2	111	30									2,000
19											17.9	109				16						



Table 2  
Traffic Observations

Pavement Temperature			Pavement Temperature			Pavement Temperature		
Coverages	Traffic Observations		Coverages	Traffic Observations		Coverages	Traffic Observations	
<u>Unit 1</u>			<u>Unit 2</u>			<u>Unit 3</u>		
<u>150,000-lb load</u>			<u>150,000-lb load</u>			<u>150,000-lb load</u>		
78*	20	Slight amount of rutting noticeable	78*	20	Slight amount of rutting noticeable	78*	20	Slight amount of rutting noticeable
68*	60	Rutting noticeable at Sta 0+05	72*	100	Rutting appears to be ironing out	68*	60	Rutting appears to be ironing out
72*	100	Rutting appears to be ironing out	70*	250*	No change	70*	250*	No change
70*	250*	No change	66*	510*	No change	66*	510*	No change
66*	320	Slight amount of cracking noticed from Sta 0+00 to 0+05	61*	750*	No change	61*	750*	No change
64*	510	CBR Pit 22 opened and tested	70*	1,000*	No change	70*	1,000*	No change
66*	510*	No change	67*	1,250*	No change	67*	1,250*	No change
61*	511	Cracks appear around CBR Pit 22 patch	64*	1,500*	No change	64*	1,500*	No change
	750*	No change	66*	1,750*	No change	66*	1,750*	No change
	800	Large amount of movement and cracking appearing from Sta 0+00 to 0+10		2,000	CBR Pit 33 opened for after-traffic tests -- end of test with 150,000-lb load		2,000	CBR Pit 40 opened for after-traffic tests -- end of test with 150,000-lb load
70*	1,000*	Sealing up of cracks from Sta 0+00 to 0+10 - CBR Pits 23, 24, and 25 opened and tested			<u>200,000-lb load</u>			<u>200,000-lb load</u>
67*	1,250*	Small cracks progressing from Sta 0+00 to 0+10		0	Pit 34 opened for "before-traffic" tests		0	Pit 41 opened for "before-traffic" tests
64*	1,500*	No change	72*	200*	No change	72*	200*	No change
63*	1,688	Small hair cracks opening and closing at Sta 0+04, varying with traffic movement	76*	506	Slight signs of rutting noted and area around Pit 34 depressed slightly	76*	506*	Slight signs of rutting noted
66*	1,750*	No change		1,056	CBR Pit 35 opened and tested	74*	1,366	Consolidation of CBR Pit 42 patch so bad that patch is repaired with cold mix -- surrounding pavement showing considerable deformation
	2,000	CBR Pit 26 opened for after-traffic tests -- end of test with 150,000-lb load	74*	1,366	Consolidation of CBR Pit 35 patch so bad that patch is repaired with cold mix -- surrounding pavement showing considerable deformation			
		<u>200,000-lb load</u>				72*	1,650*	Deflection noticed from Sta 1+00 to 1+20
	0	Pits 27 and 28 opened for "before-traffic" tests	72*	1,650*	From Sta 0+60 to 0+80 deflection is noticeable under traffic but no change in area around Pit 35 noticeable	73*	2,000	CBR Pits 43 and 44 opened and tested -- from Sta 1+00 to 1+20 the surface is badly deformed but no cracking is visible in unit except around Pit 42 patch -- end of test with 200,000-lb load
70*	24	Rutting from Sta 0+00 to 0+30 -- the cracks around pits not progressing	73*	2,000	CBR Pits 36 and 37 opened and tested -- from Sta 0+60 to 0+80 the surface is badly deformed but no cracking is visible in unit except around Pit 35 patch -- end of test with 200,000-lb load			
	108	Cracks progressing from all pit patches -- a large amount of deformation noticeable throughout unit						
72*	200*	No change						
	210**	Unit considered to have failed between Sta 0+00 and 0+08 -- traffic continued on remainder of unit						
72*	266	Considerable rutting throughout unit						
	460	CBR Pit 29 opened and tested -- CBR patch cracked when traffic resumed						
64*	610	Cracks around all pit patches progressing rapidly -- CBR Pit 30 opened and tested -- unit considered failed at 610 coverages						

(Continued)

\* Indicates direction of traffic reversed.  
\*\* After 210th coverage, number of coverages in Unit 1 does not coincide with number in Units 2 and 3.

Table 2 (Continued)

Pavement			Pavement			Pavement		
Temperature	Coverages	Traffic Observations	Temperature	Coverages	Traffic Observations	Temperature	Coverages	Traffic Observations
Unit 4			Unit 5			Unit 6		
70,000-lb load -- B-29 Assembly			70,000-lb load -- B-29 Assembly			70,000-lb load -- B-29 Assembly		
80°	28	Slight rutting caused by "before-traffic" loading tests is ironing out	80°	28	Slight rutting caused by "before-traffic" tests is ironing out	80°	28	Slight rutting caused by "before-traffic" tests is ironing out
82°	68	Some rutting appears	85°	262	Slight increase in deflection noticeable	85°	262	Slight increase in deflection
78°	136	Ruts are smoothing out	79°	430	Small amount of rutting	70°	510*	No change
79°	150	Cracks appearing at core holes at Sta 0+06	70°	510*	No change	650	650	Smoothing out of ruts continues
80°	240	Rutting more pronounced	73°	750*	No noticeable change	73°	750*	No change
85°	280	Increase in cracking at core holes at Sta 0+06	78°	1,030*	Slight amount of deflection noticeable over entire unit	78°	1,030*	Slight amount of deflection over entire unit
73°	368	Ruts from Sta 0+20 to 0+20 approach breaking point	76°	1,250*	No change	76°	1,250*	No change
76°	442	Conspicuous surface deflection measured and found to be 0.15"	60°	1,500*	No change	60°	1,500*	No change
80°	498	Slight cracking occurs from Sta 0+00 to 0+06	75°	1,750*	No change	75°	1,750*	No change
70°	510*	Ruts smoothing out after reversal of traffic	62°	2,000	CBR Pit 11 opened for "after-traffic" tests -- end of test with B-29 load	62°	2,000	CBR Pit 18 opened for "after-traffic" tests - end of test with B-29 load
650	650	Smoothing out of ruts continues	100,000-lb load -- B-50 Assembly			100,000-lb load -- B-29 Assembly		
73°	750*	No change	62°	44	All bond broken between pavement and CBR Pit 11 patches but no visible cracks	62°	50	Tiny cracks showing up around CBR Pit 18 patch
73°	844	Slight cracking between Sta 0+00 and 0+06 reappears	52°	150*	No change	52°	150*	No change
78°	1,030*	Cracks from Sta 0+00 to 0+06 reappearing	56°	264	Find hair cracks working out from CBR Pit 11 patch	54°	750*	No change
70°	1,110	Cracks from Sta 0+00 to 0+06 reappearing and disappearing	67°	470	Cracks from Sta 0+40 to 0+55	59°	1,230	No cracks visible
72°	1,210	Only a few cracks noticeable at Sta 0+00	60°	646	Cracks spreading rapidly between Sta 0+40 and 0+46	51°	1,500*	No change
76°	1,250	Crack 1/16" wide appearing and disappearing from Sta 0+00 to 0+05	68°	700	First 4 ft of unit from Sta 0+40 to 0+44, considered to have failed	51°	1,750*	No cracks visible
72°	1,400	Cracks and ruts again noticeable from Sta 0+00 to 0+05	57°	750	CBR Pits 12 and 13 opened and tested	60°	1,832	First spreading of cracks noticeable around Pit 18 patch
60°	1,500*	CBR Pit 3 opened and tested	54°	750*	Mat placed on unit from Sta 0+40 to 0+55 due to failure of unit from Sta 0+40 to 0+46	2,000	2,000	CBR Pit 19 opened for after-traffic tests - end of test with B-50 load
67°	1,516	Cracks appear around patched Pit 3	66°	790	Small hair cracks at Sta 0+58			
73°	1,540	All bond is broken in Pit 3	64°	850	Small hair cracks throughout unit			
75°	1,564	Cracks running across Pit 3	59°	1,146	Small crack near Test Pit 13 about a foot in length			
66°	1,684	Hair cracks increasing around Pit 3	51°	1,396	Hair cracks running laterally across unit at Sta 0+58			
	1,732	Additional hair cracks around Pit 3		1,500*	No change			
75°	1,750*	More small cracks appear	46°	1,632	Hair cracks opening and closing, varying with lateral traffic			
63°	1,783	Cracks 1/4" wide appear near Pit 3 - patch shows excessive movement - ruts are deeper	51°	1,750*	No change			
62°	2,000	CBR Pits 4 and 5 opened for "after-traffic" tests - small cracks still around Pit 3 - end of test with B-29 load	66°	1,952	Small hair cracks beginning to run laterally between Sta 0+70 and 0+80			
				2,000	CBR Pit 14 opened for after-traffic tests - end of test with B-50 load			

(Continued)

(Sheet 2 of 3)

Table 2 (Concluded)

Pavement Temperature	Coverages	Traffic Observations	Pavement Temperature	Coverages	Traffic Observations	Pavement Temperature	Coverages	Traffic Observations
Unit 4			Unit 5			Unit 6		
	100,000-lb load -- B-50 Assembly							
	0	CBR Pit 6 opened for "before-(B-50)-traffic" tests						
62°	16	All patches in unit broken around edge of Pit 6						
62°	20	Patch at Pit 3 broken and cracks spreading						
	42	End of unit between Sta 0+00 and 0+15 declared failed because of large ruts and broken pavement - traffic continued on remainder of unit						
	70	Cracks 1/4" wide progress to Sta 0+20						
	80	Small cracks noticeable throughout unit						
	100	Unit declared failed up to Sta 0+25 - traffic continued on remaining portion of unit						
52°	150*	No change						
	200	Hair cracks between Sta 0+25 and 0+40 increasing						
	250	CBR Pit 7 opened and tested						
	328	Entire unit declared failed - M-6 landing mat placed over area between Sta 0+30 and 0+40 to retard migration of cracks from unit 4 to unit 5						

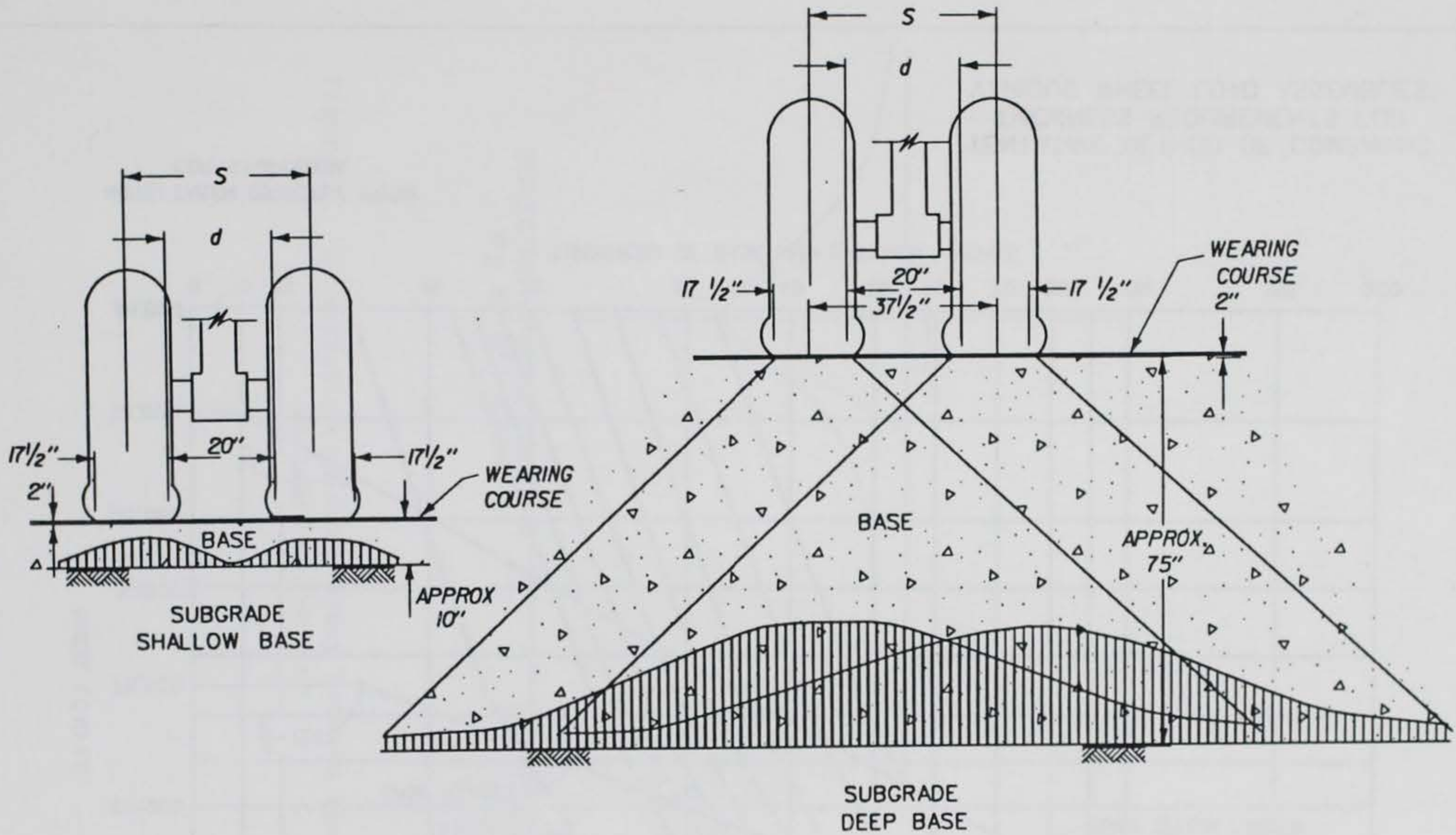

SCHEMATIC DIAGRAM OF  
B-29 DUAL WHEEL ASSEMBLY

Figure 1. Load distribution under dual wheels

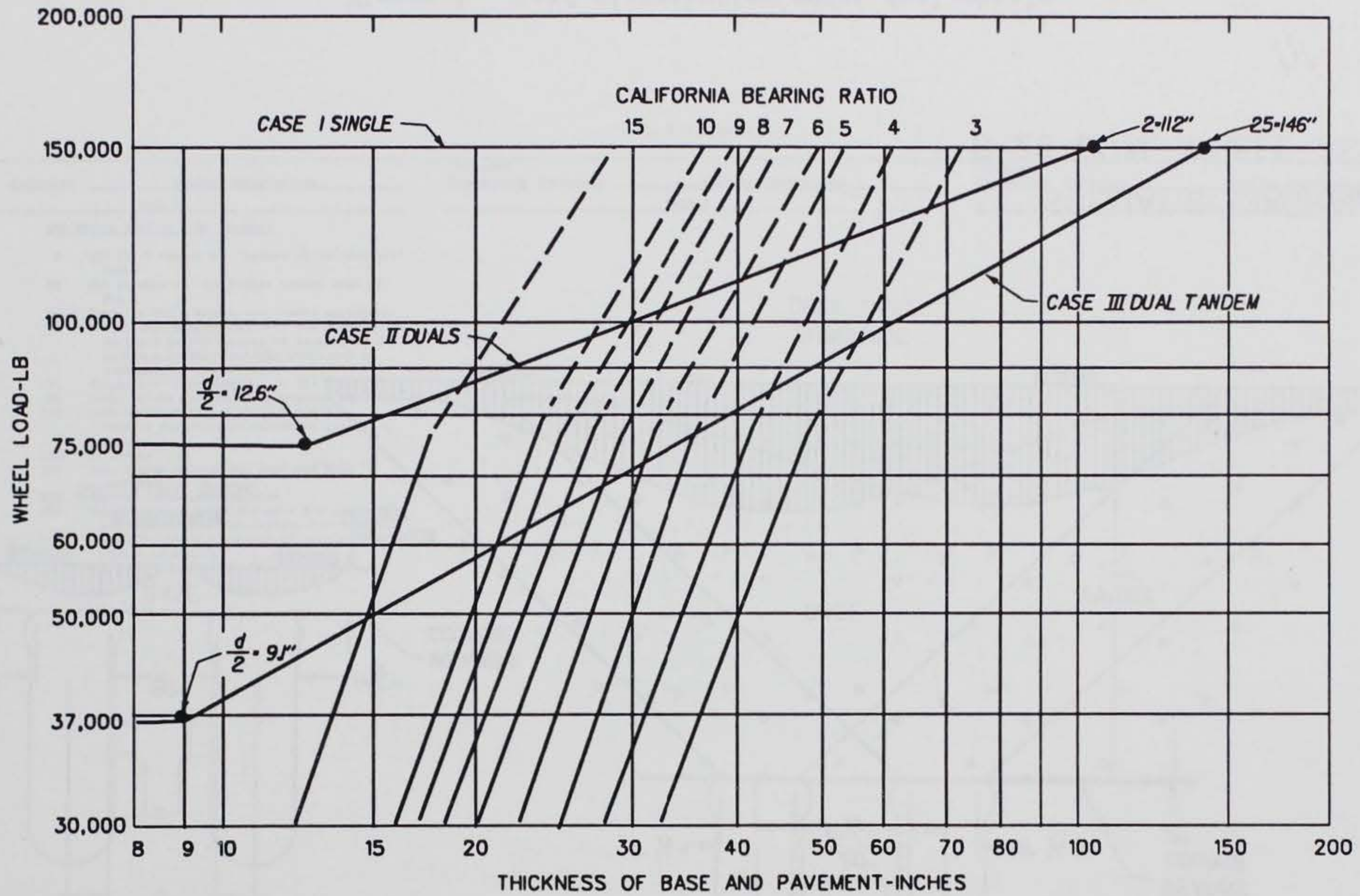

NOTE: TAKEN DIRECTLY FROM  
CBR SYMPOSIUM.

TENTATIVE METHOD OF COMPARING  
THICKNESS REQUIREMENTS FOR  
VARIOUS WHEEL LOAD ASSEMBLIES

Figure 2. Illustration of  $d/2 - S$  method

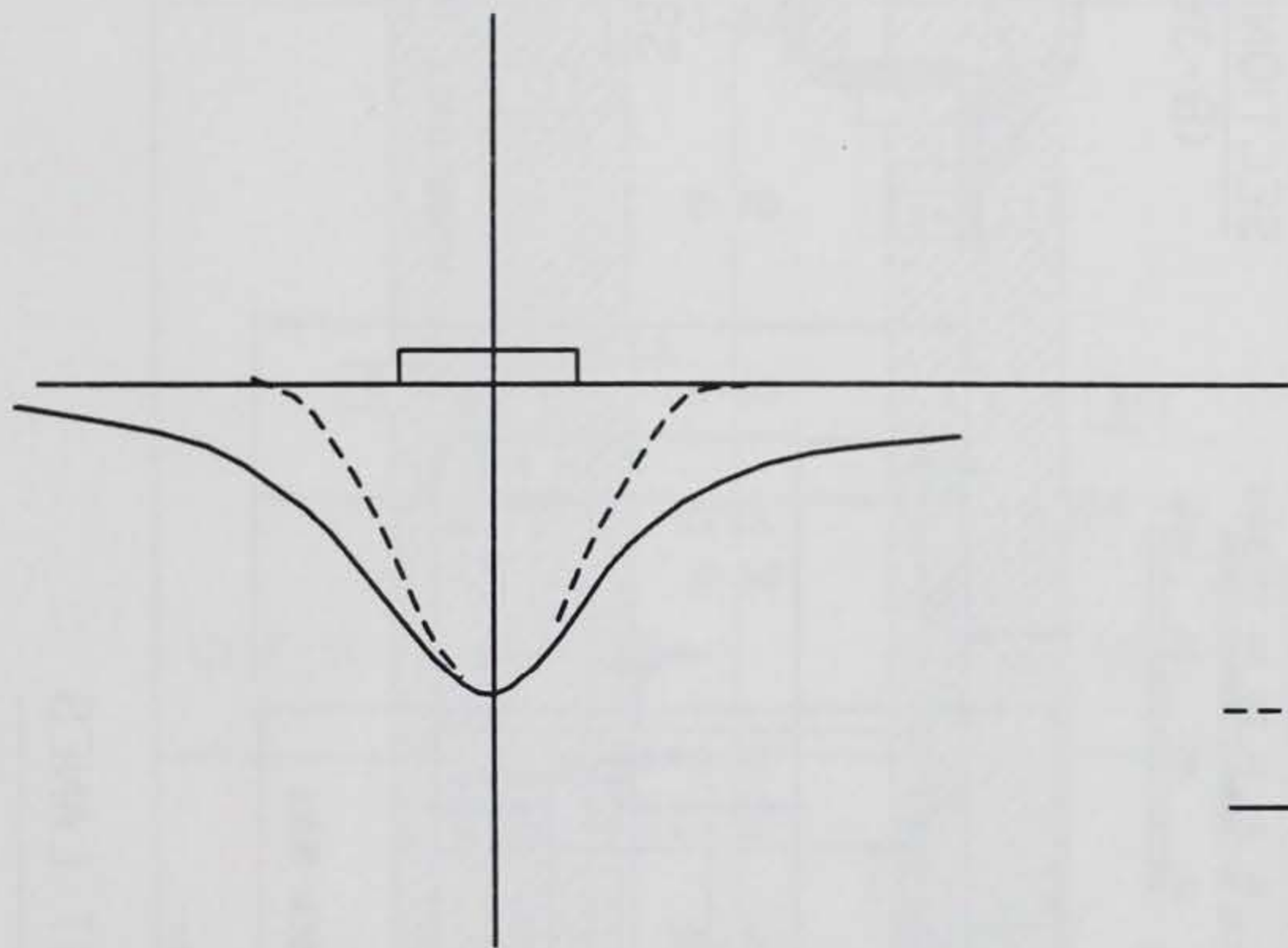

LEGEND

----- MEASURED  
 ————— THEORETICAL

DEFLECTION vs OFFSET DISTANCE  
 $W_z$  AT 1-FT DEPTH

TAKEN FROM:  
 TM 3-323  
 INVESTIGATIONS OF PRESSURES  
 AND DEFLECTIONS FOR  
 FLEXIBLE PAVEMENTS  
 REPORT •4  
 DEC.1954

Figure 3. Illustration of discrepancy between theoretical and measured deflection

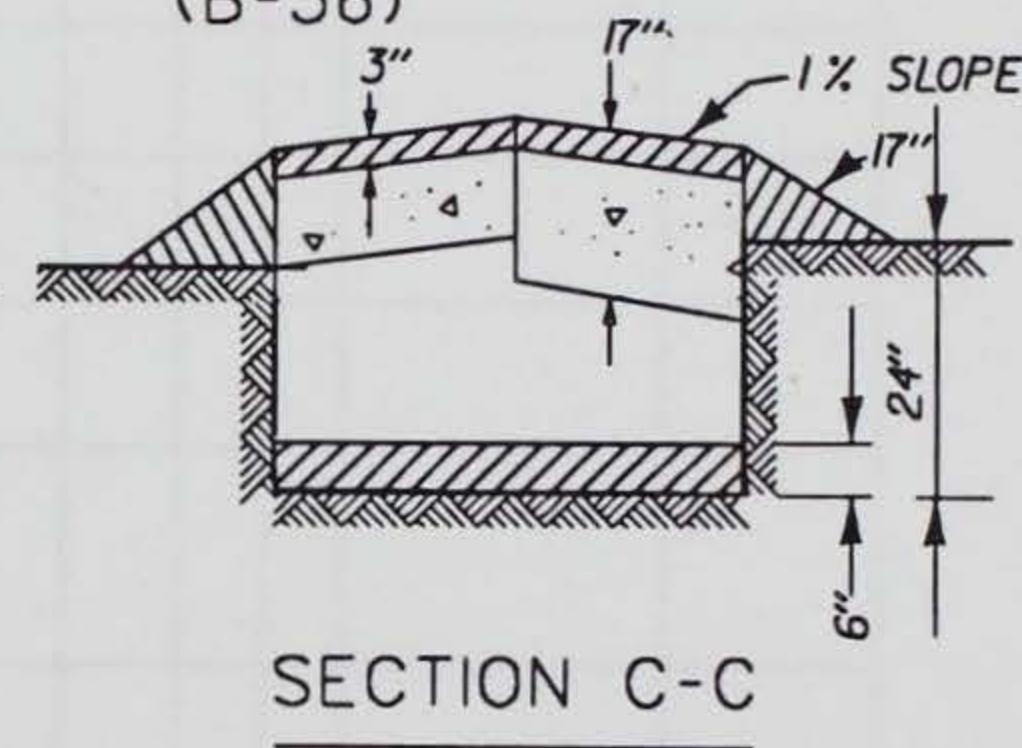
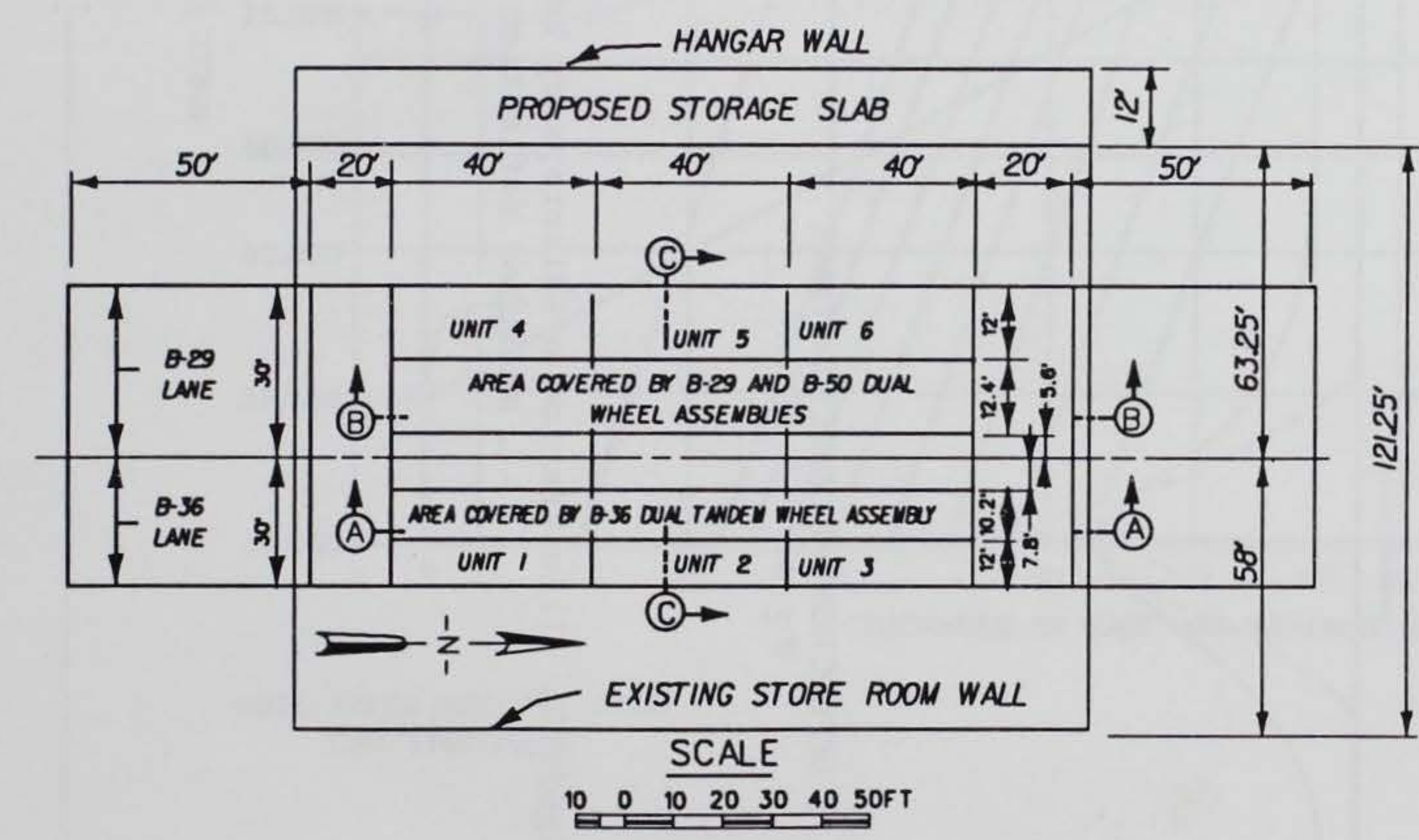
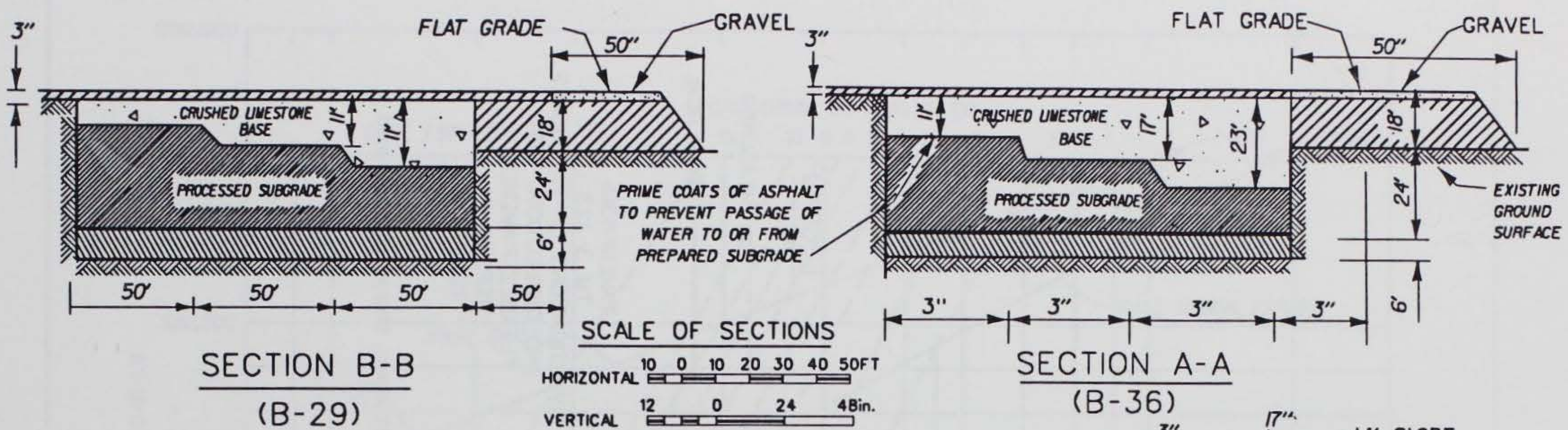

NOTE: BASE THICKNESS WAS BASED ON SUBGRADE CBR OF 15 PERCENT

LAYOUT OF TEST LANES

Figure 4. Layout and cross sections of test lanes

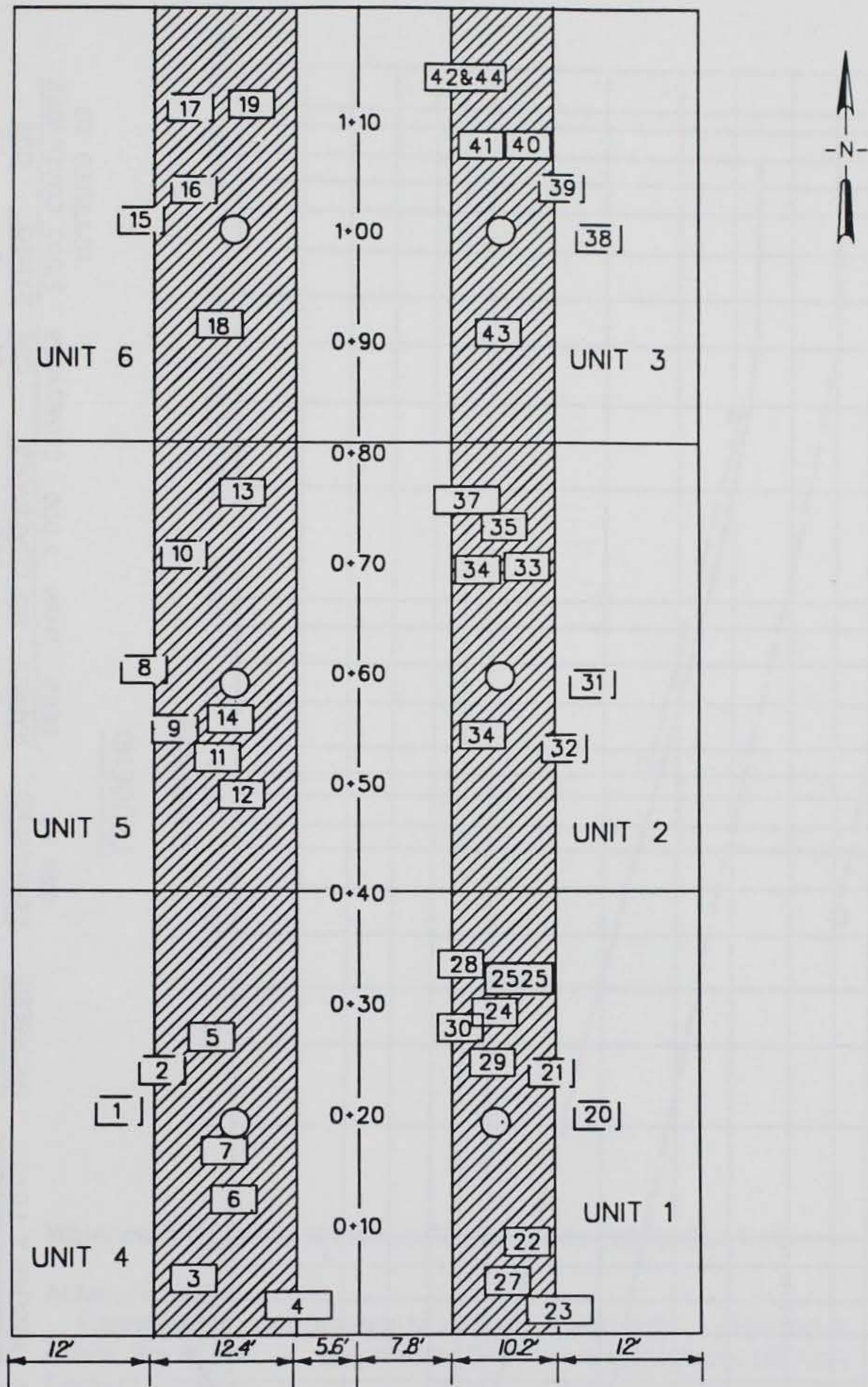

**LEGEND**

- ☐ TEST PITS OPENED PRIOR TO CONSTRUCTION OF WEARING COURSE.
- ☐ TEST PITS OPENED THRU WEARING COURSE.
- ▨ TRAFFICKED AREA
- SELSYN MOTOR DEFLECTION GAGE

Figure 5. Location of test pits and deflection gages



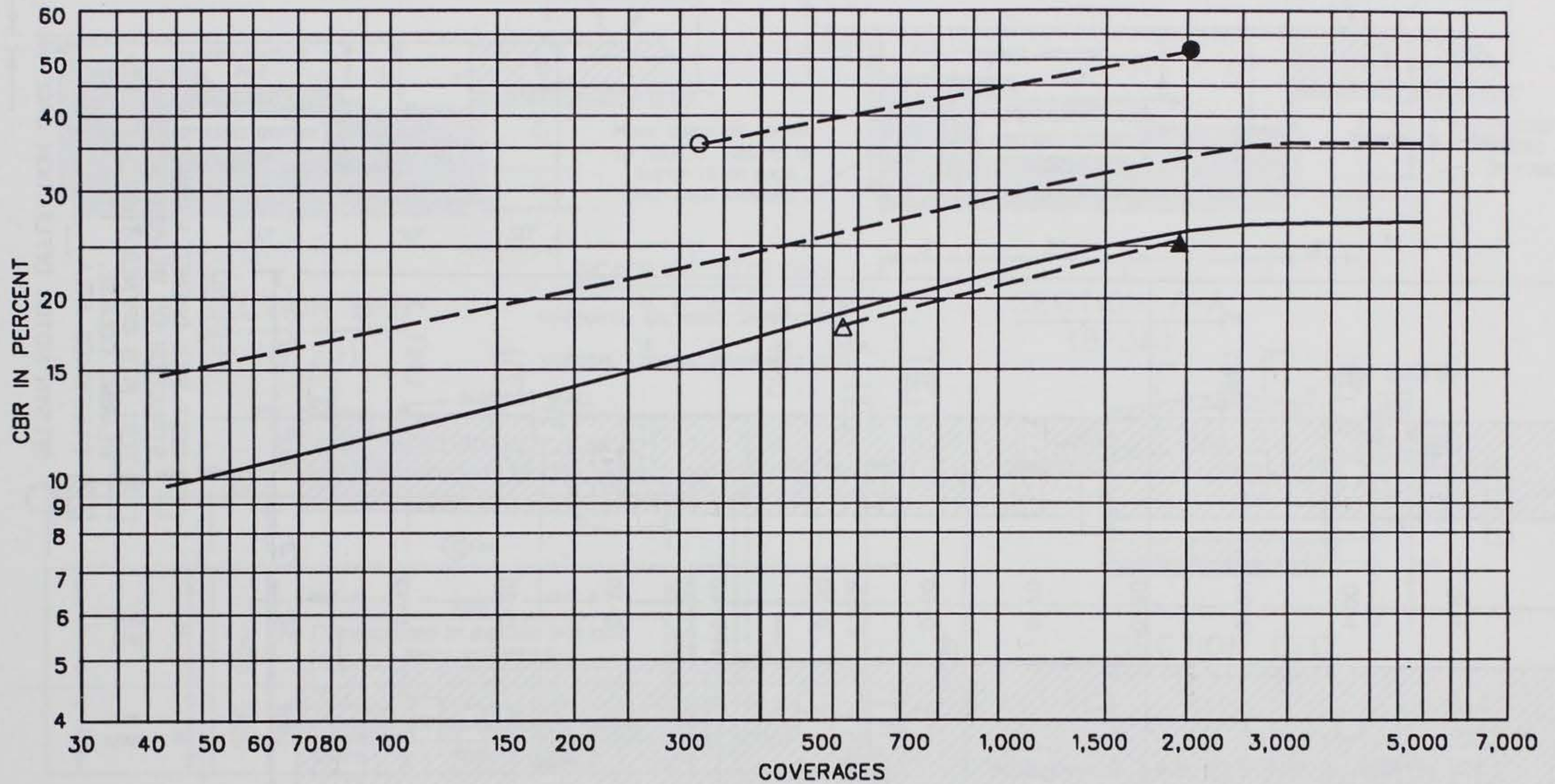

LEDGEND

UNIT	ASSEMBLY LOAD	THICKNESS	CBR VS COVERAGES	LESS THAN 2,000 COVERAGES			ADJUSTED TO 2,000 COVERAGES	
				SYMBOL	NO. COVERAGES	CBR	SYMBOL	CBR
4	100,000 LB (B-50)	10 IN.	-----	O	328	35	●	50
1	200,000 LB (B-36)	14 IN.	—————	Δ	610	18	▲	25

Figure 6. CBR versus coverages