

TA7
W34m
no. GL-81-3
cop. 2



US-CE-C Property of the United States Government



MISCELLANEOUS PAPER GL-81-3

OVERVIEW FOR DESIGN AND CONSTRUCTION OF DRILLED SHAFTS IN COHESIVE SOILS

by

Lawrence D. Johnson, Walter C. Sherman, Jr.
Mosaid M. Al-Hussaini

Geotechnical Laboratory
U. S. Army Engineer Waterways Experiment Station
P. O. Box 631, Vicksburg, Miss. 39180

August 1981

Final Report

Approved For Public Release; Distribution Unlimited



Prepared for Office, Chief of Engineers, U. S. Army
Washington, D. C. 20314

LIBRARY BRANCH
TECHNICAL INFORMATION CENTER
US ARMY ENGINEER WATERWAYS EXPERIMENT STATION
VICKSBURG, MISSISSIPPI

REPORT DOCUMENTATION PAGE		READ INSTRUCTIONS BEFORE COMPLETING FORM
1. REPORT NUMBER Miscellaneous Paper GL-81-3	2. GOVT ACCESSION NO.	3. RECIPIENT'S CATALOG NUMBER
4. TITLE (and Subtitle) OVERVIEW FOR DESIGN AND CONSTRUCTION OF DRILLED SHAFTS IN COHESIVE SOILS		5. TYPE OF REPORT & PERIOD COVERED Final report
		6. PERFORMING ORG. REPORT NUMBER
7. AUTHOR(s) Lawrence D. Johnson Walter C. Sherman, Jr. Mosaid M. Al-Hussaini		8. CONTRACT OR GRANT NUMBER(s)
9. PERFORMING ORGANIZATION NAME AND ADDRESS U. S. Army Engineer Waterways Experiment Station Geotechnical Laboratory P. O. Box 631, Vicksburg, Miss. 39180		10. PROGRAM ELEMENT, PROJECT, TASK AREA & WORK UNIT NUMBERS Work Unit AT40/E0/006
11. CONTROLLING OFFICE NAME AND ADDRESS Office, Chief of Engineers, U. S. Army Washington, D. C. 20314		12. REPORT DATE August 1981
		13. NUMBER OF PAGES 122
14. MONITORING AGENCY NAME & ADDRESS (if different from Controlling Office)		15. SECURITY CLASS. (of this report) Unclassified
		15a. DECLASSIFICATION/DOWNGRADING SCHEDULE
16. DISTRIBUTION STATEMENT (of this Report) Approved for public release; distribution unlimited.		
17. DISTRIBUTION STATEMENT (of the abstract entered in Block 20, if different from Report)		
18. SUPPLEMENTARY NOTES Available from National Technical Information Service, 5285 Port Royal Road, Springfield, Va. 22151.		
19. KEY WORDS (Continue on reverse side if necessary and identify by block number) Cohesive soils Drilled pier foundations Pile load tests Shafts (Excavations)		
20. ABSTRACT (Continue on reverse side if necessary and identify by block number) Drilled shaft foundations have become very important in construction of numerous types of structures such as residences, buildings, bridges, and towers on expansive or unstable soils and fills. Much research has been done to improve the design and construction procedures for drilled shafts, but few reports contain criteria for different soils and loading conditions. This report updates and condenses previous work and presents procedures available for design and construction of drilled shaft foundations in cohesive soil under various loading conditions. Guidance is presented for field exploration. (Continued)		

20. ABSTRACT (Continued)

laboratory investigations, design concepts and procedures, and construction techniques.

The results of the overview show that design procedures are generally highly conservative, particularly those using total stress methods. Such conservatism has frequently been relied upon because no rational basis exists for determining the empirical factors, particularly the reduction factor α , required for the total stress methods. Failures of drilled shaft foundations have consequently been associated mostly with construction problems rather than with design.

New research should include development of improved and more rational design methods to reduce unnecessary conservatism, determination of long-term effects on drilled shafts, improvements in construction methods, and techniques for troubleshooting problems with drilled shafts.

PREFACE

This report is an overview for design and construction of drilled shafts in cohesive soils. It is the first phase in a continuing research and development effort leading to improved design procedures and guidelines in support of Work Unit AT40/E0/006, "Development of Methodology for Design of Drilled Piers in Cohesive Soils," sponsored by the Office, Chief of Engineers, U. S. Army.

The report was prepared by Dr. Lawrence D. Johnson, Research Group (RG), Soil Mechanics Division (SMD), Geotechnical Laboratory (GL), U. S. Army Engineer Waterways Experiment Station (WES), with the assistance of Mr. Walter C. Sherman, Jr., RG, SMD, and Dr. Mosaid M. Al-Hussaini, formerly with the RG, SMD. The work was performed under the supervision of Mr. Clifford L. McAnear, Chief, SMD, and Mr. James P. Sale, Chief, GL. Mr. W. R. Stroman, Foundations and Materials Branch, U. S. Army Engineer District, Fort Worth; Dr. Edward B. Perry, RG, SMD; Mr. Gerald B. Mitchell, Chief, Engineering Studies Branch, SMD; and Mr. Richard G. Ahlvin, former Assistant Chief, GL, reviewed the report and provided many helpful comments.

COL J. L. Cannon, CE, and COL N. P. Conover, CE, were Directors of WES during the preparation of the report. Mr. F. R. Brown was Technical Director.

CONTENTS

	<u>Page</u>
PREFACE	1
CONVERSION FACTORS, INCH-POUND TO METRIC (SI) UNITS OF MEASUREMENT	3
PART I: INTRODUCTION	4
Background	4
Purpose and Scope	11
PART II: FIELD INVESTIGATIONS	12
General Requirements	12
Surface Examination	12
Subsurface Explorations	13
PART III: LABORATORY INVESTIGATIONS	17
Classification Tests	17
Strength Tests	18
Swell and Consolidation Tests	21
PART IV: DESIGN PROCEDURES	22
Axial Load Behavior of Single Shafts	22
Lateral Load Behavior of Single Shafts	54
Load Behavior of Groups	65
Evaluation of Design Methods	70
PART V: CONSTRUCTION METHODS	73
Equipment	73
Construction Procedures	79
Construction Problems and Inspection	85
PART VI: RECOMMENDATIONS FOR RESEARCH	94
REFERENCES	95
APPENDIX A: IN SITU TESTS	A1
Standard Penetration Test	A1
Cone Penetration Test	A3
Vane Shear Test	A4
Borehole Pressuremeter Test	A6
Field Load Test	A9
APPENDIX B: NOTATION	B1

CONVERSION FACTORS, INCH-POUND TO METRIC (SI)
UNITS OF MEASUREMENT

Inch-pound units of measurement used in this report can be converted to metric (SI) units as follows:

<u>Multiply</u>	<u>By</u>	<u>To Obtain</u>
feet	0.3048	metres
foot-pounds (force)	1.355818	newton-metres
foot-tons (force)	2.7085881	kilonewton-metres
inches	2.54	centimetres
inches	25.4	millimetres
kips (1000 lb force)	4.448222	kilonewtons
kips (force) per square foot	47.880263	kilopascals
pounds (force) per square inch	6.894757	kilopascals
pounds (mass)	0.45359237	kilograms
pounds (mass) per gallon (U. S. liquid)	0.11982642	kilograms per litre
quarts (U. S. liquid)	0.9463529	litres
square feet	0.09290304	square metres
square feet per ton (mass)	1.0240807	square centimetres per kilogram
tons (2000 lb force)	8.896444	kilonewtons
tons (force) per cubic foot	0.31417495	megapascals per metre
tons (force) per square foot	95.76052	kilopascals
tons (2000 lb mass)	907.18474	kilograms
tons (mass) per cubic foot	32.036934	grams per cubic centimetre

OVERVIEW FOR DESIGN AND CONSTRUCTION
OF DRILLED SHAFTS IN COHESIVE SOILS

PART I: INTRODUCTION

Background

1. The selection of a suitable foundation for a structure should be based on a thorough knowledge of site and soil conditions and an evaluation of the relative advantages of alternative types of foundations. The choice depends on such considerations as the design and loading requirements of the structure, effects of construction on nearby structures, availability of equipment, accessibility of construction equipment to the site, type of soil, permissible noise level, and relative costs. Deep foundations such as drilled shafts or concrete cylinders cast into boreholes provide an economical method to transfer structural loads beyond (or below) unstable (weak, compressible, swelling) surface soil down to deeper, stable (firm, nonswelling) strata. Figure 1 illustrates a typical drilled shaft with an enlarged base. Other terms used to describe the drilled shaft are "drilled pier," "drilled caisson," "augered foundation," and "bored pile." Texas experience (Reed 1978) has shown that a drilled shaft is generally more economical than other forms of piling if the hole can be bored.

2. The drilled shaft is often chosen over other foundation systems if the borehole can be readily and rapidly drilled, the bearing formation is at depths accessible to available equipment, the site is reasonably level and firm and has adequate overhead clearance, and the building code permits drilled shaft foundations (Woodward, Gardner, and Greer 1972). Drilled shafts have special advantages in swelling or compressible soils where loads can be carried below depths of seasonal moisture changes into stable strata. Uplift forces from swelling of adjacent soil or downdrag from consolidating fills can be resisted by constructing underreams (enlarged bases or bells) in deeper stable strata or by

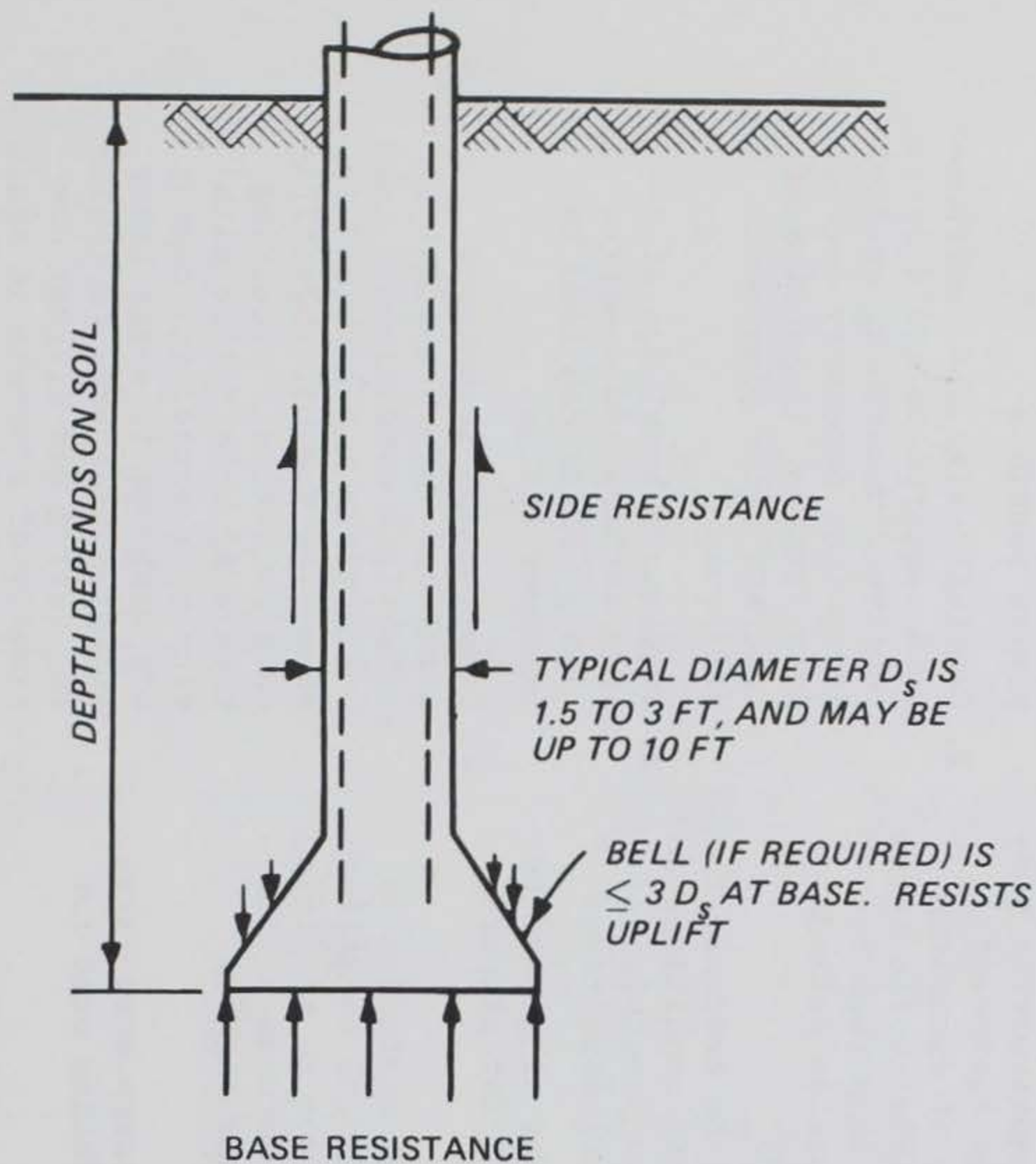

Figure 1. Typical drilled shaft

extending the shaft length deeper into stable strata. The concrete can also be cast in smooth polyethylene sleeves or PVC or can be coated with bitumen slip layers to reduce skin friction on the shaft (Patey 1977, Claessen and Horvat 1974). Large-diameter shafts can be more easily constructed to resist lateral loads than driven piles or other foundation types. Table 1 describes various applications of drilled shafts and lists advantages and disadvantages.

3. Drilled shafts develop their bearing capacity from side friction and end bearing or base resistance. A typical classification of drilled shafts, categorizing them into three types depending on the relative contribution of skin friction and end bearing resistance, is presented in Figure 2. The load capacity of shafts in stiff, homogeneous soil (Figure 2a) is derived from a combination of the frictional skin and end bearing resistance. A bell is sometimes provided to increase

Table 1

Applications of Drilled Shafts*

Applications	Advantages	Disadvantages
1. Absence of shallow, stable, founding stratum; support of structures with shafts drilled through swelling soils into zones unaffected by moisture changes	1. Personnel, equipment, and materials for construction usually readily available; rapid construction possible due to mobile equipment; careful inspection of excavated hole usually possible; noise level of equipment less than that for some other construction methods; low headroom needed	1. Accurate predictions of load and settlement behavior not always possible
2. Support of moderate to high column loads; high column loads with shafts drilled into hard bedrock; moderate column loads with underreamed shafts bottomed on sand and gravel	2. Excavated soil can be examined to check projected soil conditions and profile; excavation possible for wide variety of soil conditions	2. Careful design and construction required to avoid defective foundations; careful inspection necessary during construction; inspection of concrete after placement difficult
3. Support of light structures on friction shafts	3. Heave and settlement at ground surface normally small for properly designed shafts	3. Inadequate knowledge of design methods and construction problems can lead to improper design
4. Rigid limitations to structure deformation; differential heave or settlement exceeds 2 to 3 in.; large lateral variations in soil conditions	4. Disturbance of soil minimized by drilling, thus reducing consolidation and dragdown due to remolding compared to other methods of placing deep foundations such as driving	4. Construction techniques sometimes very sensitive to subsurface conditions: (a) susceptible to "necking" in squeezing ground; (b) difficult to concrete requiring tremie if hole filled with slurry or water; (c) cement may wash out if water under artesian pressure; (d) pulling casing can disrupt continuity of concrete in shaft or displace/distort reinforcing cage
5. Structural configurations and functional requirements or economics preclude mat or other foundation: (a) resist uplift forces from swelling soils, (b) provide anchorage to pulling, lateral, or overturning forces	5. Single shaft can carry very large loads often eliminating need for cap 6. Changes in geometry (diameter, penetration, underream) can be made during construction if required by subsurface conditions	5. Heave beneath base of slab can aggravate movement beneath slab on ground

* From Jobes and Stroman (1974), Jennings and Evans (1962), Chen (1975), and Reese and Wright (1977).

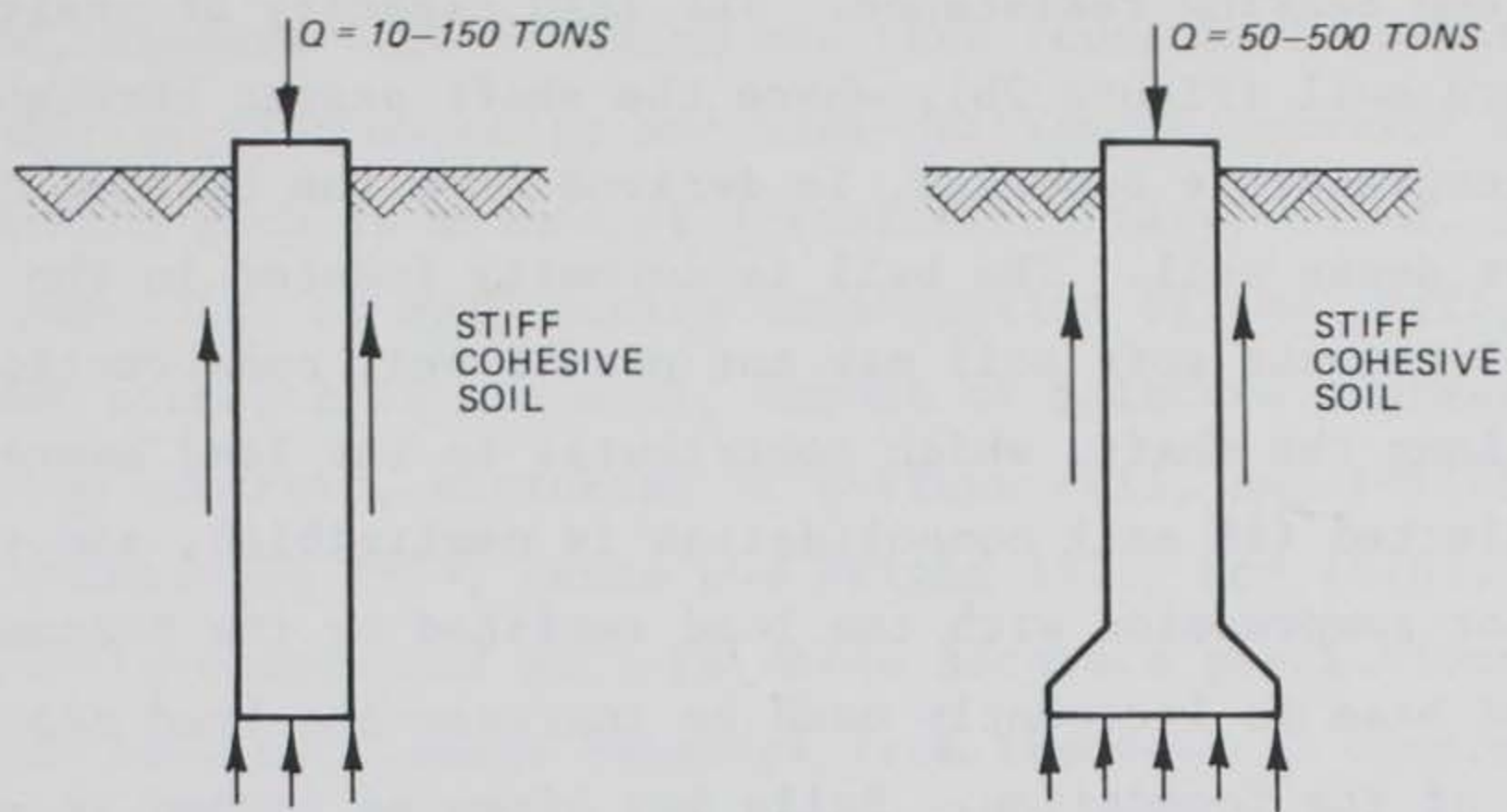

a. Floating shafts in homogeneous soil

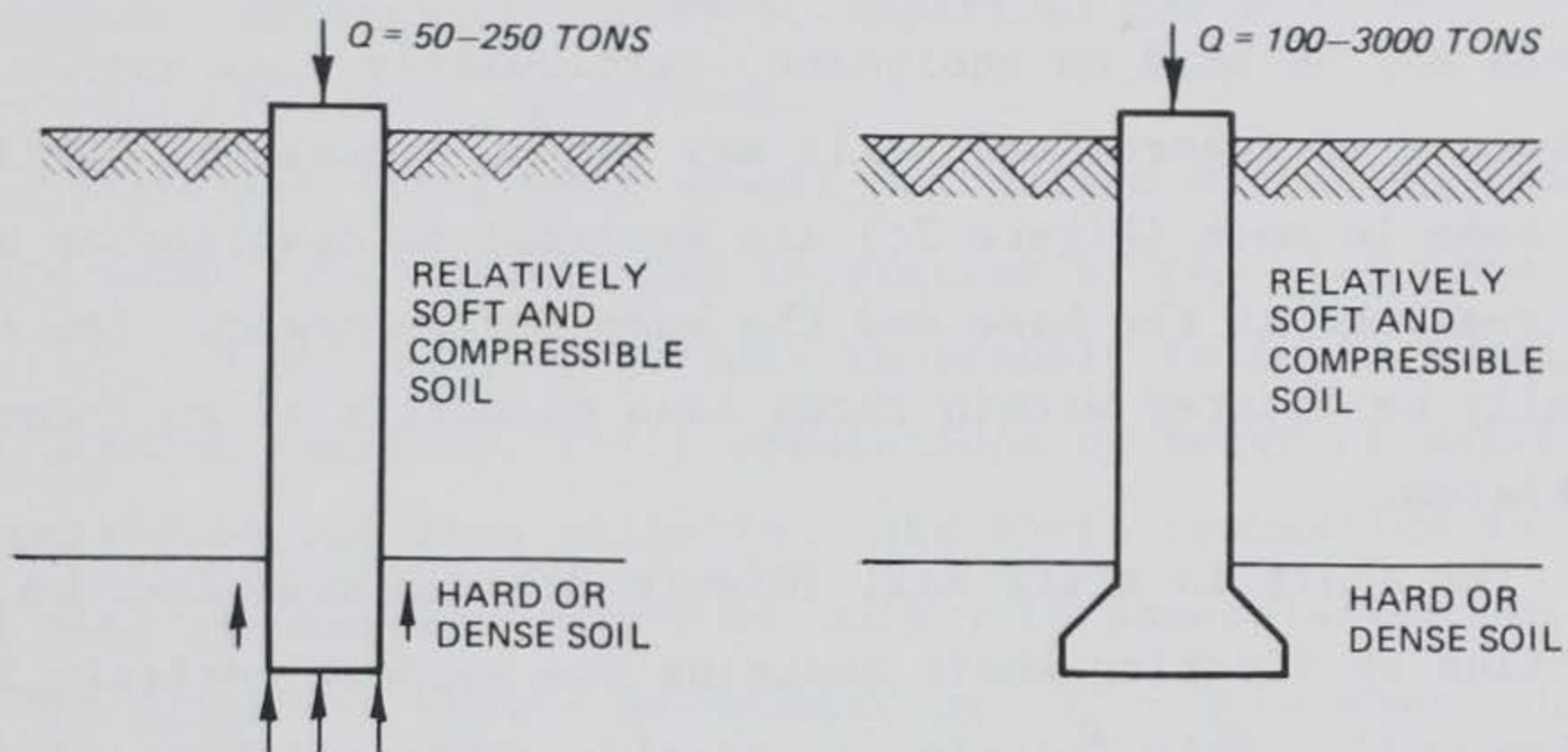

b. Shafts end bearing in hard soil

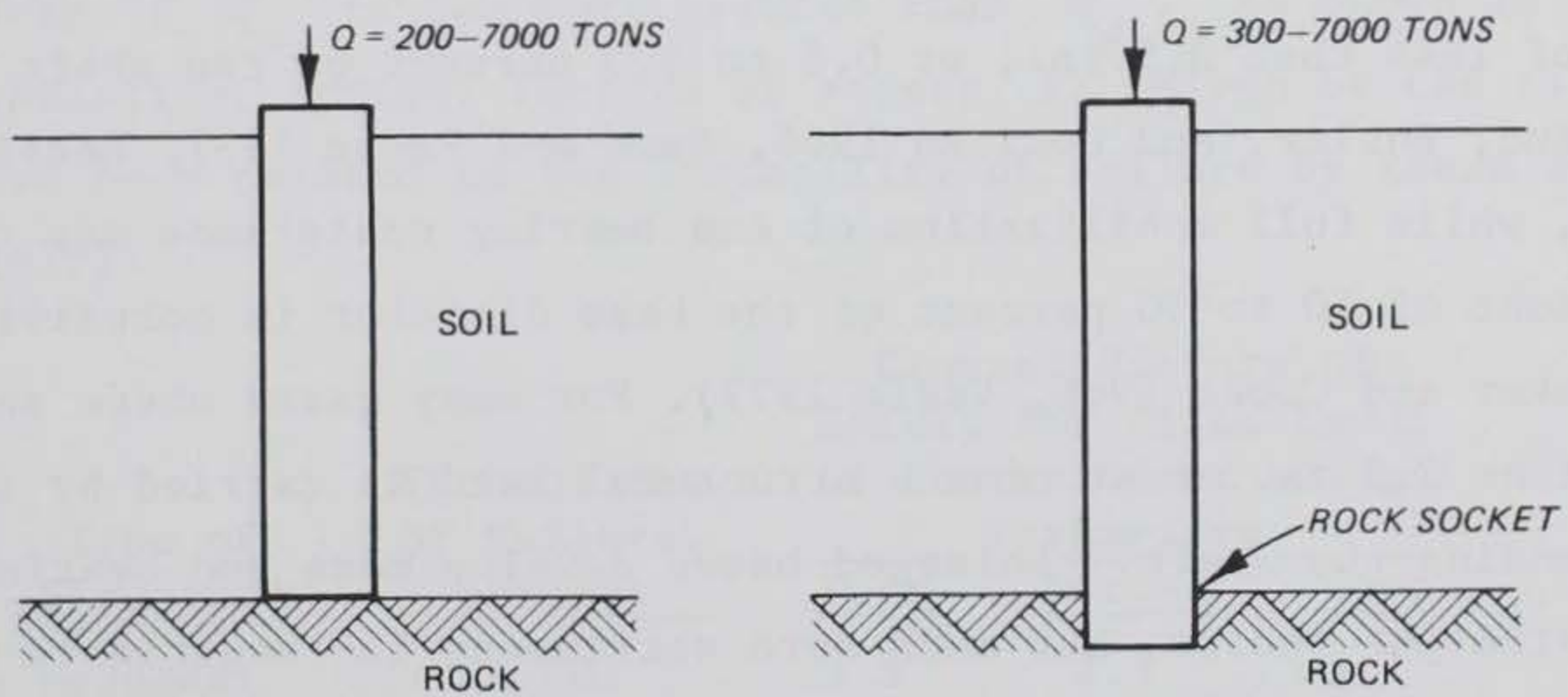

c. Shafts end bearing in rock

Figure 2. Principal classifications of drilled shafts with respect to supporting soil (after Winterkorn and Fang 1975)

uplift or end bearing resistance. The load capacity of shafts with the base in hard soil (Figure 2b), where the shaft passes through relatively soft and compressible deposits, is derived from the bearing capacity of the hard or dense soil. The bell is normally located in the hard, cohesive soil because soft soil may not permit bell construction. Positive friction along the shaft, which contributes to the load bearing capacity, may be neglected (if soil consolidation is negligible), and the shaft is designed for compression with the load resisted by the bottom reaction. An enlarged base is frequently used to increase the load capacity or uplift resistance of the foundation. Bells may often be formed in materials having unconfined strengths of from 10 to 15 tsf.* Materials with variations in hardness may be hard on equipment, particularly clay shales interbedded with limestone stringers, and bells may not be practical. Drilled shafts with the base in rock (Figure 2c) are designed as compression members with the load resisted at the base and the base not enlarged. The base should not normally be located within three base diameters of an underlying unstable stratum.

4. The shaft in stiff soil (Figure 2a) may sometimes be designed as a friction or floating shaft securing its support entirely from the surrounding soil. Skin friction is usually substantial and developed at a fraction of the settlement required to develop end bearing resistance. For example, skin friction is fully mobilized after a downward displacement of less than 0.5 in., or 0.5 to 3.0 percent of the shaft diameter (Burland, Butler, and Dunican 1966, Seed and Reese 1957, Reese and Wright 1977), while full mobilization of end bearing resistance may require displacement of 10 to 30 percent of the base diameter in cohesive soils (Whitaker and Cooke 1966, Vesic 1977). For many cases where settlement is less than 0.5 in., most of the structural load is carried by the soil surrounding the shaft. Enlarged bases develop more end bearing resistance than straight shafts, but much more settlement is required to mobilize this resistance (Tomlinson 1977). More drilled shafts have recently been designed with straight shafts and shorter lengths compared to earlier designs, particular where swelling soils have not been a problem

* A table of factors for converting inch-pound units of measurement to metric (SI) units is presented on page 3.

(Reese 1978, because skin friction has been found to be substantial.

5. The bearing capacity and load-settlement behavior are dependent on many factors such as method of installation (dry, cased, or slurry), extent of remolding of soil during construction of the shaft, fissures in and shear strength of the soil, amount of moisture migrating into the soil from the concrete, shrinkage of surface soil, and relief of lateral pressures (Tomlinson 1975, Reese and Wright 1977, Hoy 1978). The effect of these little-understood factors makes accurate predictions of bearing capacity and load-settlement behavior from theoretical concepts nearly impossible. Drilled shafts are presently designed based on a combination of simple theoretical concepts, empirical correlations, limited load test data, and past experience.

6. Heave and settlement should not exceed specified limits determined from usage requirements and tolerances of the structure. The present state of the art usually permits reasonably reliable predictions of ultimate bearing capacity, while predictions of heave or settlement of shaft foundations are less reliable. The shaft foundation is therefore designed with an adequate margin of safety to assure satisfactory performance. The margin of safety is denoted by $Q_u - Q_w$, where Q_u is the ultimate bearing capacity of the soil and Q_w is the applied load. Failure occurs if Q_u is less than Q_w , but the foundation will be overdesigned if Q_u is too much greater than Q_w . As shown in the following tabulation, central factors of safety FS given by the ratio of Q_u/Q_w have been related to the probability of failure by Reese and Wright (1977):

Type of Structure	Probability of Failure, percent	Central Factors of Safety for Cited Level of Control Over Design Parameters		
		Poor	Normal	Good
Monument	0.001	3.5	2.3	1.7
Permanent	0.01	2.8	1.9	1.5
Temporary	0.1	2.3	1.7	1.4

The central factor of safety combines partial factors of safety with respect to (a) strength of soil, (b) quality of construction, (c) design

errors and limitations in theory, (d) reduction of load to an acceptable or safe level, and (e) changes in load due to errors, change in use of structure, construction effects, creep, and an incorrect assumed probability density function. An FS for the poor or normal level of control is recommended as the minimum overall factor of safety (Reese and Wright 1977). A "poor" FS indicates that very little is known about the design parameters or that there is considerable scatter in the data.

7. Experience (Burland, Butler, and Dunican 1966, Tomlinson 1975, Vesic 1977, Reese and Wright 1977) has shown that working loads Q_w of one third to one half of the ultimate bearing capacity Q_u usually lead to total settlements that are predominantly elastic and less than 0.5 in. Such loading ratios are consistent with the poor and normal FS values shown above for permanent structures. Long-term settlements from consolidation and creep of the soil appear insignificant (Wooley and Reese 1974). Working loads are usually conservative since many structures can tolerate total settlements of 2 to 3 in. without becoming unserviceable (Reese and Wright 1977). However, the economic loss due to unattractive architectural disturbance or disruption of operations for maintenance can certainly detract from the usefulness of otherwise completely serviceable structures. Sometimes, lower factors of safety may be applied where there is an abundance of local experience. A consolidation settlement analysis may be necessary if the soil zone influenced by the base load includes relatively soft and compressible layers.

8. The design process for drilled shafts should include subsurface exploration, laboratory testing, selection of the shaft design, and selection of the more promising construction procedures. The subsurface exploration program should be adequate for establishing the technical and economical feasibility of using drilled shafts. Adequate laboratory tests for determining and further refining the engineering properties of the bearing strata are also useful in establishing feasibility of drilled shaft foundations; e.g., determining the cohesion and potential for sloughing and caving in boreholes. Shaft design requires the determination of the length, diameter, reinforcement, and allowable working loads.

The chosen construction procedure should be sufficiently flexible to allow modification and improvements as necessary by the contractor to accommodate actual field conditions.

Purpose and Scope

9. During the past decade, there has been considerable research on drilled shaft foundations, both in the United States and abroad. In spite of the large amount of published data, there are very few single, self-contained sources that an engineer can use for the design of drilled shafts under different loading and soil conditions. Furthermore, current design practice requires the use of empirical correlations which may not be applicable at new construction sites or for different construction methods. Field load tests are often necessary to confirm the proposed design. Load tests, however, may be economically prohibitive for small construction projects. Much experience and expertise are often necessary to interpret load tests and properly design and construct drilled shaft foundations. Where load tests have been performed in Texas (Hoy 1978), the results have permitted better definition of factors of safety and higher bearing pressures than those proposed.

10. The purpose of the study under which the report was prepared is to provide Corps engineers with guidelines and design criteria for economical and efficient design and construction of drilled shafts in cohesive soils for most loading conditions. This report summarizes the results of a study on field exploration, laboratory investigations, methodology available for design of drilled shafts in cohesive soil, and construction procedures. Various design methods are compared with results of field load tests to evaluate the relative usefulness of each design procedure. Construction problems and solutions are presented to help avoid defective shafts and subsequent unsatisfactory performance of the foundation. Future work involves the development of improved design guidelines and construction techniques. Effective stress analysis is one approach that will be investigated to improve design guidelines.

PART II: FIELD INVESTIGATIONS

General Requirements

11. The design and construction of structures proposed to be founded on drilled shafts should be preceded by a well-planned investigation of the surface and subsurface conditions at the site. The investigation should be conducted in sufficient detail to establish that deep foundations are actually required and that drilled shafts are the most economical and practical alternative for supporting the structure. A judgment should be made early in the investigation that drilled shafts are a viable alternative so that the investigation can be tailored to develop required information for their design. The scope of the investigation will depend on the nature and complexity of subsurface materials and the size of, requirements for, and cost of the structure.

12. The field investigation should be carried out in two major phases: a surface examination and subsurface explorations. A third phase, which complements the second phase, consisting of in situ tests (see Appendix A) may also be required. The surface examination must be conducted first since its results determine the extent of the subsurface explorations. The surface examination can itself be divided into three separate activities consisting of (a) gathering documentary evidence, (b) field reconnaissance, and (c) gathering local experience. On military posts this information is usually readily available. The subsurface exploration is generally divided into preliminary and detailed phases.

Surface Examination

Documentary evidence

13. The logical and necessary first step in any field investigation is a survey of all pertinent information on geological and soil conditions at and in the vicinity of the site. Local geological records and publications and federal, state, and institutional surveys provide good sources of information on subsurface soil features. Procedures for conducting such a survey are described in Technical Manual 5-818-1

(Headquarters, Department of the Army 1961) and Engineer Manual 1110-2-1804 (Headquarters, Department of the Army in publication).

Field reconnaissance

14. A thorough visual examination of the site and its environment by the foundation engineer, preferably in company with a geologist, is a necessity. This activity may be combined with the gathering of local experience. Relevant items which should be considered in field reconnaissance include (Reese and Wright 1977):

- a. Restrictions on access.
- b. Locations of utilities and restrictions concerning removal or relocation.
- c. Locations of existing structures at and adjacent to the site. Description of foundation types employed. Complete visual examination and obtain photographs if it can be reasonably expected that adjacent structures may be affected by construction operations.
- d. Locations of trees and other major surface vegetation and restrictions concerning removal or disposition.
- e. Surface drainage including presence of surface water.
- f. Contour maps of site. Delineation of fill areas, rock outcrops, or other topographic features.
- g. Possible condition of ground at time of construction in relation to trafficability of construction equipment.

Local experience

15. Local experience is very helpful in indicating possible design and construction problems and soil and groundwater conditions at the site. Past successful methods of design and construction, recent innovations, and cost effective and feasible new methods of design should be examined to assess their usefulness for the proposed structure. In addition, any local information pertaining to the use of drilled shaft construction and performance would be extremely useful. Construction techniques, equipment employed, and problems encountered during drilled shaft construction are pertinent items.

Subsurface Explorations

Preliminary phase

16. The purpose of preliminary subsurface explorations is to

obtain rough soil profiles and representative samples from the principal strata or to determine bedrock profiles. Auger or split spoon borings as described in EM 1110-2-1907 (Headquarters, Department of the Army 1972) are commonly used for obtaining representative samples. The borings may be supplemented by geophysical methods on large projects. Methods and techniques for geophysical methods are described in EM 1110-2-1802 (Headquarters, Department of the Army 1948). On smaller projects, the preliminary phase is usually conducted in conjunction with the detailed subsurface explorations described subsequently. Representative sampling by means of auger or split spoon equipment can be sufficient in itself where drilled shafts are to be founded on rock and the properties of the rock and overburden are known from local experience. However, subsurface investigations must be of sufficient scope and detail to satisfy legal requirements imposed by the contract.

Detailed subsurface explorations

17. In most cases, the preliminary subsurface explorations will not be sufficient to provide the necessary data for design of drilled shafts, and more detailed investigations will be necessary. The purpose of the latter explorations is to obtain detailed soil profiles and undisturbed samples for special laboratory tests. The explorations should provide sufficient information to indicate whether or not cylindrical holes of the proper size and underreams, if needed, can be excavated by normal construction techniques without the soil caving, sloughing, heaving, or exhibiting excessive lateral deformation. Soils of concern include soft clays, stiff fissured clays, and cohesionless materials. Practically continuous sampling by means of open-drive samplers, piston samplers, or core-boring samplers is used for deeper explorations. Rotary core double barrels are often used in inert soils and soils containing gravel. A single barrel with a diamond head is necessary for rock. Large-diameter borings approaching the geometry expected to be made during construction of the shafts also provide the highest quality undisturbed samples and permit direct observation of the foundation soils. Examination of the shaft walls may reveal relevant details such as thin, weak layers or sand seams that may not be detected even by continuous undisturbed borings. In situ penetration and sounding tests or vane shear

tests (Appendix A) may be conducted to supplement available information. Undisturbed samples 4 in. or more in diameter are preferable for determination of the consolidation and strength characteristics of the foundation soils.

18. Location and spacing. In exploration of extensive areas, the borings should be located so as to supplement or extend the information obtained from the fact-finding and geological survey. Borings with a rigid pattern or spacing often will not disclose unfavorable conditions; therefore, it is preferable to space the borings so as to define the geologic units and soil nonconformities. Spacings of 50 or 25 ft, and occasionally to even lesser distances, may be required when erratic subsurface conditions are encountered. In exploration of structure sites, the initial borings should preferably be located close to the corners of the area, and the number of borings should not be less than three unless subsurface conditions are known to be very uniform. These preliminary borings must be supplemented by intermediate borings as required by the extent of the area, location of drilled shafts, and the soil conditions encountered.

19. Depth of exploration. Unless preliminary information is unusually good, the required depth of exploration cannot be intelligently established until a few borings have been completed. As a general rule, all preliminary borings should extend to strata of adequate bearing capacity, and should penetrate all soft or loose deposits even though they may be overlain by layers of stiff or dense soils. Assuming that a reasonable estimate can be made of the drilled shaft lengths, the borings should extend well below the anticipated base level. Generally, borings may be stopped when rock is encountered or after a penetration of 10 to 20 ft into strata of exceptional stiffness, provided it is known from geological information or explorations in the vicinity that these strata have adequate thickness or are underlain by still stronger formations. The utmost precaution is necessary to insure that boulders are not mistaken for a rock stratum. When the drilled shafts are to be founded on rock, it is advisable to penetrate some distance (usually 5 to 10 ft) into the rock to determine the extent and character of the rock.

20. Rock quality. The principal rock properties of concern for

installation and design of drilled shafts are structural features and shear strength. In situ properties of rock can be inferred from the Rock Quality Designation (RQD). These properties and their methods of determination are described in Technical Manual 5-818-1 (Headquarters, Department of the Army 1961).

Groundwater observations

21. Knowledge of groundwater conditions is an important element in design and construction of drilled shafts. Every effort should be made to determine the position of the water table, its seasonal variation, and how it may be affected by tides or adjacent bodies of water. The presence of perched water tables or artesian pressures below the base of the drilled shaft should be thoroughly evaluated. Particular attention should be given to sandy strata which contain perched water tables only during certain times of the year. The most reliable and frequently the only satisfactory means for determining groundwater levels is by use of piezometers. Types of piezometers, construction details, and sounding devices are discussed in EM 1110-2-1908 (Headquarters, Department of the Army 1971). The presence of harmful ingredients in the groundwater such as sulphates should be established by appropriate laboratory tests.

PART III: LABORATORY INVESTIGATIONS

22. Design of drilled shafts in cohesive soil requires knowledge of the physical properties of the foundation soil. Appropriate physical properties are normally determined from classification, strength, and swell/consolidation tests. The physical properties should be determined for each type of soil down to depths of at least five base diameters below the proposed base elevation of the shaft. The depth of soil testing needs to be increased if group load effects on drilled shafts (spacings less than eight shaft diameters) significantly increase the depth of soil in which loading pressures are significant.

Classification Tests

23. Classification tests help to describe the nature or type of soil. The most useful classification tests, as detailed in TM 5-818-1 and EM 1110-2-1906 (Headquarters, Department of the Army 1961 and 1970), include Atterberg limits, specific gravity, water content, void ratio, and grain size distribution.

24. The Atterberg limits provide a qualitative measure of the attraction of water to the soil particles and have been found to be related to soil suction (Livneh, Kinsky, and Zaslavsky 1970, Russell and Mickle 1971), volume changes (Snethen, Johnson, and Patrick 1977) and shear strength (Wroth and Wood 1978).

25. Water contents and Atterberg limits can be used together to evaluate the liquidity index of the soil (Lambe and Whitman 1969), a measure of the relative loss of shear strength on remolding. Construction causes at least some disturbance of the natural soil surrounding the shaft (e.g., relief of lateral pressure, change in water content, soil smear at the shaft-soil interface). Soils with higher liquidity indices $I_L = (\text{natural water content} - PL)/PI$ promote restoration of the initial stresses following installation of the shaft. The soil strength reduction coefficient α (see paragraph 45) may also be directly related or proportional to I_L . I_L has also been related to the undrained strength (Wroth and Wood 1978) as

$$c_u = 170 e^{-4.6I_L} \quad (1)$$

where c_u is in kilopascals.

26. The grain size distribution, determined from sieve and hydrometer analyses, is a useful indicator of relative cohesion and permeability. Decreasing particle size increases capillarity (i.e., ability to raise water above the natural groundwater level) and increases effective cohesion c for a given water content. The activity A (PI divided by percent 0.002 mm) of the soil (Skempton 1953) can provide a rough measure of the contribution of cohesion c to the shear strength τ_s

$$\frac{c}{\tau_s} \approx \frac{4A}{4A + 10} \quad (2)$$

Fine-grained soils also exhibit low permeability.

Strength Tests

27. The results of strength tests are used to estimate the bearing capacity and load-deflection behavior of the shaft foundation. Shear strength as a function of depth is needed to evaluate adhesion or skin friction of the soil surrounding the shaft and to evaluate ultimate bearing capacity. Young's modulus of the supporting soil and of the shaft are necessary for predicting load-deflection behavior. In most cases, the critical time for bearing capacity is immediately after completion of construction (first loading) prior to any significant consolidation under the loads carried by the shafts. Either total or effective stress analyses can be performed to evaluate bearing capacity. However, total stress analyses are preferred because of their relative simplicity as discussed below.

Total stress analysis

28. Undrained strength tests are used in total stress analysis to roughly approximate the drainage and loading conditions that occur in the field during first loading. There is little time for drainage in the relatively impermeable cohesive soils. Total stress undrained tests

are relatively simple; they do not require measurements of pore water and lateral pressures and, consequently, are commonly performed. However, obtaining adequate undisturbed soil samples and trimming them for testing can be difficult, especially soil samples of fissured and stiff (overconsolidated) clays.

29. Some serious limitations are associated with undrained shear strengths (Kulhawy, Sangrey, and Clemence 1978). The undrained strength is much more variable than the drained strength. The measured undrained strength is also much more susceptible to errors in sampling and testing, particularly with sensitive and overconsolidated clays. Strength anisotropy is also important in evaluating undrained strength such that care should be exercised to apply the correct anisotropic strength of the actual shear surface. The in situ shear strength can be lower than the laboratory undrained strength in moderately to heavily overconsolidated clays because negative pore pressures produced during undrained shear may dissipate rapidly in the field due to fissures, other minor geologic detail, and the failure surface itself. Empirical relationships such as the α factor are available for relating wall adhesion forces with the mechanical shear strength as discussed in Part IV.

30. The most common undrained tests performed on undisturbed specimens are the unconfined compression (UC), unconsolidated-undrained (Q), and the consolidated-undrained (R) tests. The Q and R tests should be performed at confining pressures equal to the in situ vertical overburden total stress (O'Neill and Reese 1972, Gardner 1975). The UC test tends to underestimate strength because sample disturbance decreases the effective stress. The effect of confinement on strength is also neglected. The R test may overestimate strength because it reduces sample disturbance and tends to cause smaller water contents on reconsolidation. The Q test may be the most representative test simply because of compensating errors (Lambe and Whitman 1969). The lower limit in scatter of the undrained triaxial test results (Burland, Butler, and Dunican 1966) or mean results (O'Neill and Reese 1972) have been used when estimating in situ shear strength of stiff, fissured clays. The lower limit is recommended if there is considerable scatter in the test

results because fissures and other geologic detail may lead to lower in situ strengths than the mean value of laboratory test results. Lower strengths are also usually the result of natural fissures in the undisturbed test specimen and therefore the more appropriate design value. Full-size 6-in.-diam by 12-in.-high specimens give more consistent unconfined or triaxial compression test results than smaller 1.4- by 3-in. specimens. A small percentage of tests may be discarded. A method of statistical sample analysis is provided by Harr (1977).

Effective stress analysis

31. Effective stresses may also be used to predict short-term bearing capacity and load-deflection behavior, but the initial pore pressure or reliable estimates of the Skempton pore pressure parameter A should be made for the soils adjacent to the shaft. Effective stress analysis may be most appropriate for long-term behavior, when reliable field data and pore pressures are available from piezometers. Laboratory tests to evaluate skin friction resistance may be performed on the remolded soil because construction disturbs and remolds soil adjacent to the shaft.

32. The types of laboratory tests needed to perform effective stress analysis are the R test with pore pressure measurements and the drained (S) direct shear test. These tests can be used to determine the adhesion c_a and angle of skin friction ζ between the soil and the concrete needed for analysis. However, attempts to simulate in situ conditions complicate these tests: (a) concrete roughness should simulate that of the shaft and (b) wet concrete should be placed on the surface of the soil specimen and allowed to cure similar to that of the shaft. The shear failure plane between concrete and soil occurs in the soil about 0.1 to 0.25 in. from the concrete-soil interface. The angle of skin friction between the soil and shaft concrete is usually very close to the effective angle of internal friction ϕ' of the remolded cohesive soil or the residual ϕ'_r of the undisturbed soil at large strain (Vesic 1977). The adhesion of a remolded cohesive soil should be near zero.

Swell and Consolidation Tests

33. The results of swell tests are used to estimate the vertical movement of cohesive soils from swell or consolidation. The movements may subsequently be used to evaluate uplift or downdrag forces exerted on the drilled shaft by the surrounding soils and the resulting movements of the shaft. The test data may also be used to determine long-term shaft movement from changes in moisture conditions and load transfer in soils surrounding the shaft and in subsoils beneath the base.

34. The types of swell tests include consolidation and soil suction tests. The standard consolidation test described in EM 1110-2-1906 or a modification of this test described by Johnson (1979) may be used to estimate both swell and settlement. Consolidometer swell tests tend to predict minimal levels of heave, whereas soil suction tests tend to overestimate heave compared with field observations (Johnson 1979). These soil suction tests have been found to be easier, simpler, and take less time than consolidometer tests.

PART IV: DESIGN PROCEDURES

35. The drilled shaft foundation is designed on the basis of the functional requirements of the supported structure, conditions at the construction site, results of field exploration, and results of soil tests. The design includes the diameter and length of the drilled shaft, diameter of underream if needed, steel reinforcement, and optimum spacing between shafts to maintain structural integrity of the foundation and to keep soil deformations within the allowable tolerance.

36. Deflections that occur when the structural loads are transferred to the soil are the primary concern of the design. The structural design (Reese and Allen 1977) which assures adequate strength in the shaft to resist the loads is usually not a problem in properly constructed shafts. Buckling or shear failure rarely occurs in friction shafts unless the shaft is subject to lateral soil movement such as from downhill creep of surface soil. The design should be conservative if soil conditions are erratic or have not been completely determined. This part describes the generally more useful procedures for analysis of axial and lateral load behavior of single shafts and groups of shafts. An evaluation is provided at the end of this part that briefly reviews significant aspects of the design of drilled shafts.

Axial Load Behavior of Single Shafts

37. Axial loads are resisted by skin friction along the shaft-soil interface and by the bearing capacity of subsoil or rock beneath the base. The side resistance that is mobilized is a function of the settlement of the shaft or relative displacement between the shaft and the adjacent soil. An additional downward or upward thrust can be exerted on the shaft from consolidating or swelling soil surrounding the shaft, respectively. Pullout forces such as from eccentric or wind loads are resisted by skin friction of the surrounding soil, self weight of the shaft, and the restraining influence of any bell.

Axial loading

38. Applied axial loads cause a nonlinear settlement of the shaft (Figure 3). Figure 4 illustrates the distribution of load on the shaft with depth in clay in which the skin friction transfers load to the soil. Side resistance appears to increase with depth in sands and driven piles in clay (Wright and Reese 1979). The full skin friction resistance Q_{su} is mobilized before the full end bearing resistance Q_{bu} and nearly always at deflections less than 0.5 in. Base resistance Q_b continues to increase until the ultimate capacity Q_u develops. The ultimate settlement ρ_u at which Q_u is attained varies widely. Many definitions have been made for Q_u , of which the suggestion of settlement ρ_u at 10 percent of the shaft diameter (Terzaghi and Peck 1967), based on data from Williams and Colman (1965), is among the most practical. Vesic (1977) recommends ρ_u at 25 percent of the diameter for drilled shafts.

39. Underreams allow the shaft to carry more load in end bearing, but larger settlements can occur with identical loading pressures because a greater volume of subsoil is stressed beneath the base. Shafts with more than one underream (underreams bored at depths between the top and base) may significantly (a) increase the bearing capacity compared to a single underream at the base and (b) decrease the settlement for a given load (Jain and Gupta 1972, Poulos 1968), but multiunderreams are not usually practical. Advantages are small compared to the cost of forming and insuring that the multiple bells are filled with concrete. Methods described in the following paragraphs for predicting effects of applied axial loads include limit analysis, elastic analysis, transfer function analysis and finite element analysis.

40. Limit analysis. Limit analysis allows estimates of Q_u and the safe working load Q_w , which is most often taken between one third and one half of Q_u (i.e., a factor of safety of 3 to 2). Deflections at Q_w are usually less than 0.5 in. Deflections may also be estimated by a simple elastic assumption for soil behavior (see Table 2). Creep is usually insignificant for Q_w less than one half of Q_u (Tomlinson 1975, 1977).

41. Limit methods use empirical factors valid for local soils and

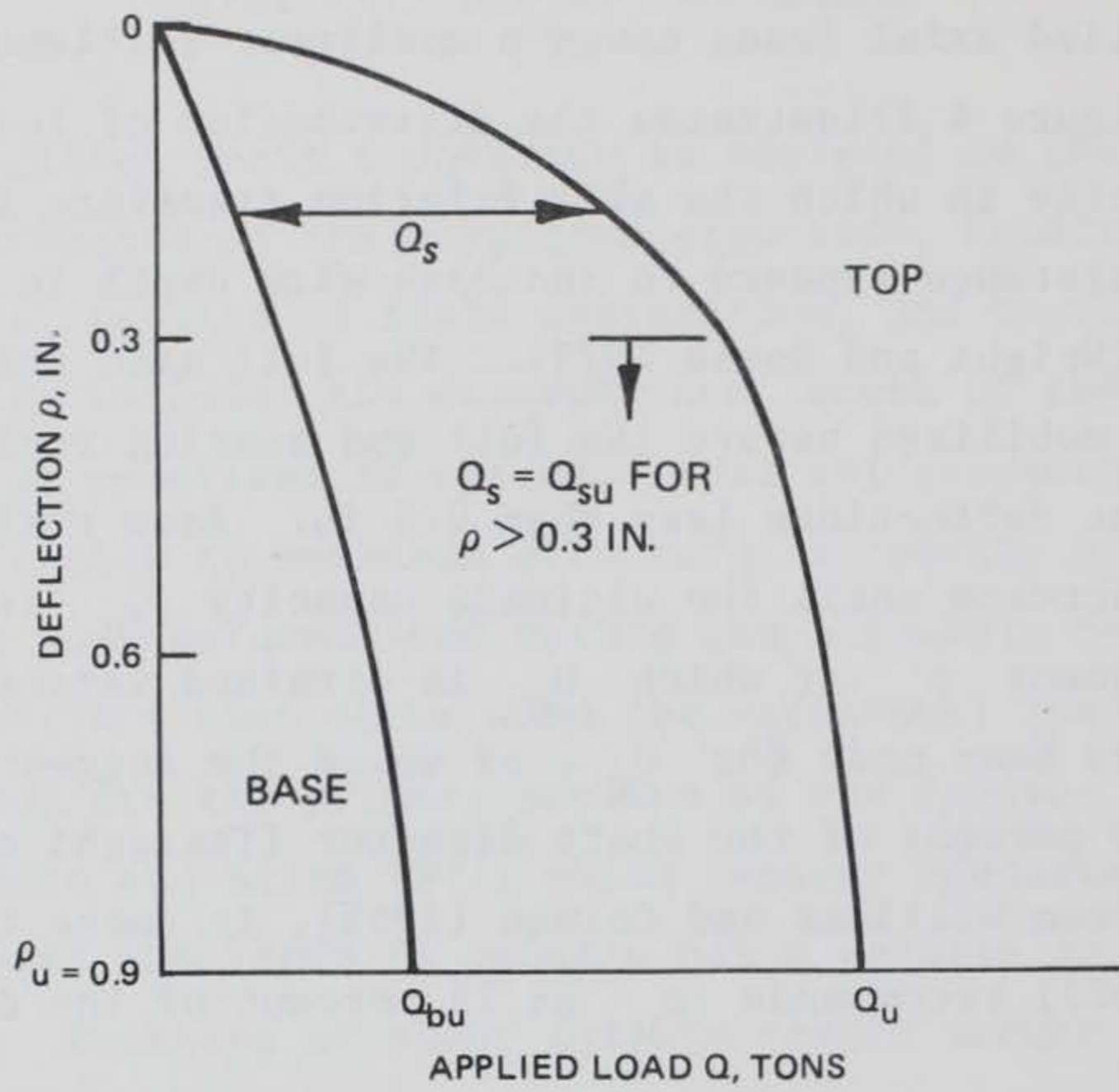

Figure 3. Axial load-deflection relationship

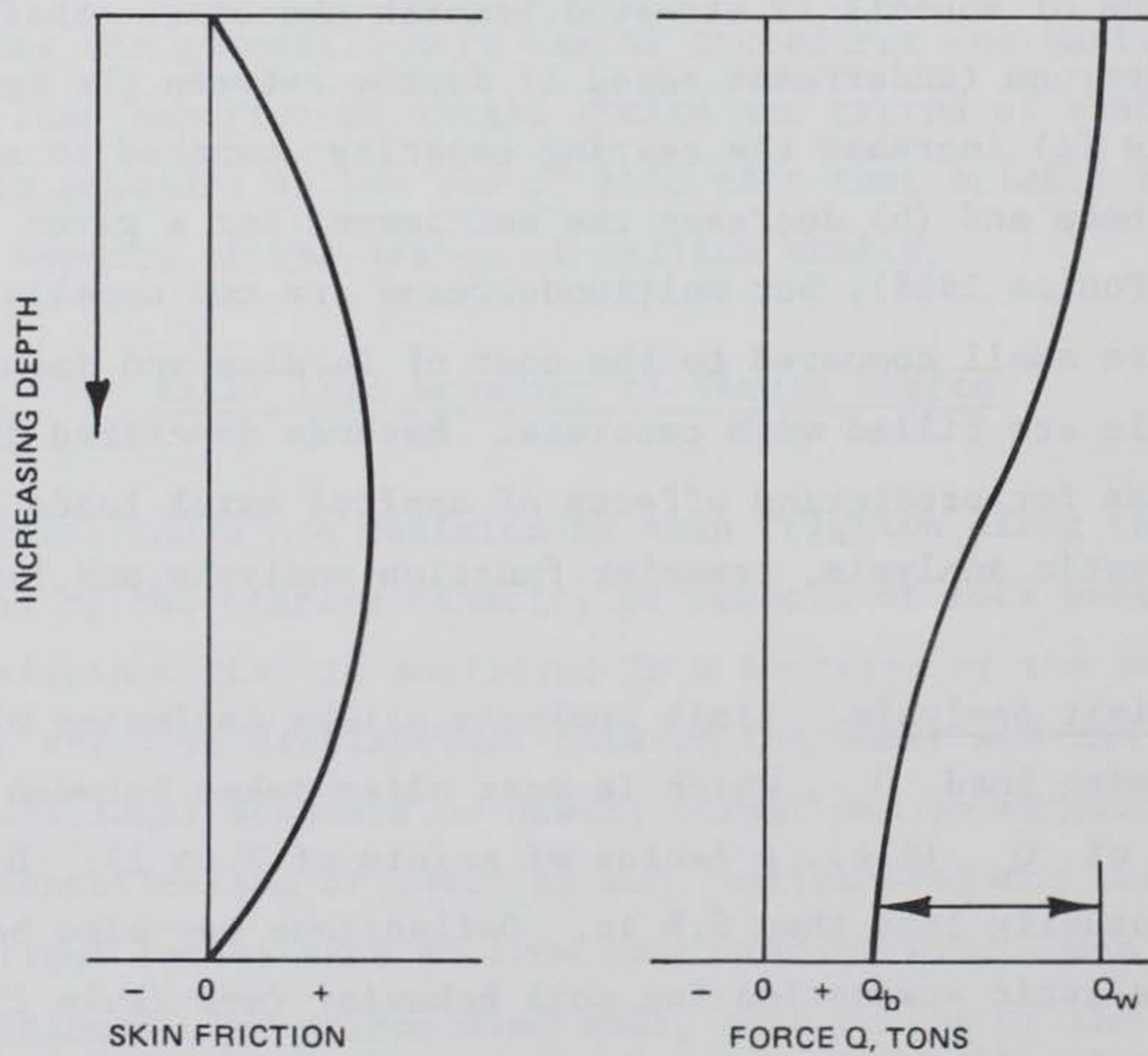

Figure 4. Distribution of axial load with depth

Table 2

Reduction Factor α for Limit Analysis

Method	Reduction Factor α	Working Load Q_w	Comments
Reese, Touma, and O'Neill (1976)	Straight shafts:	$Q_{su} + \frac{Q_{bu}}{3}$	Immediate settlement < 1 in. Top and bottom 5 ft not considered in area A_s
	Dry or displaced slurry = 0.5		
	Some slurry trapped = 0.3		
	Base on soil stiffer than shaft = 0.0		
	Belled shafts:		
	Dry or displaced slurry = 0.3		
O'Neill and Reese (1972)	$(\alpha_{11}\alpha_{12}\alpha_{13})\alpha_2\psi$; $\alpha_{11} = 0.65$ for cylindrical shaft, $\alpha_{12} = \alpha_{13} = 1 - (2.5/L)$ where L is in feet; $\alpha_2 = 1$; $\psi = 0.6$ if casing and mud used; $\psi = 1$ for dry conditions		
	Fissured, low construction control = 0.3	$\frac{Q_{su} + Q_{bu}}{2.5}$	$f_s \leq 1$ tsf
	Mean of triaxial test results = 0.45		
	Adequate local experience, load tests = 0.6		
Whitaker and Cooke (1966)*	Same as for Skempton (1959)	$\frac{Q_{su} + Q_{bu}}{2}$	
Burland and Cooke (1974)*	Same as for Skempton (1959)	Straight: $\frac{Q_{su} + Q_{bu}}{2}$	Shaft settlement = $0.005D_s$ at Q_{su}
		Belled: $Q_{su} + \frac{Q_{bu}}{3}$	
Burland, Butler, and Dunican (1966)*	Straight shafts = 0.45	Lesser of $\frac{Q_{su} + Q_{bu}}{2}$ or $Q_{su} + \frac{Q_{bu}}{3}$	Base settlement = $D_b K(Q_w - Q_{su})/Q_{bu}$ $0.005 \leq K \leq 0.02$. Use $K = 0.02$ for conservative design
	Belled shafts = 0.3		
Tomlinson (1975)*	Small diameter, long delay in placing concrete after drilling = 0.3	$\frac{Q_{su} + Q_{bu}}{2}$	Total settlement unlikely to exceed 0.4 in.
	Firm, stiff clays, $f_s \leq 1$ tsf = 0.45		
	Very soft to soft clays = 1.0		

* Based on London clay.

regions, but often extended to other areas to estimate roughly the behavior of shaft foundations for other design cases. The load-settlement curve cannot be reliably predicted. Interaction of stresses resulting from the skin and end bearing resistance is small (Burland, Butler, and Dunican 1966) and assumed negligible such that (Vesic 1977)

$$Q_u = Q_{su} + Q_{bu} \quad (3)$$

$$Q_{su} = \pi D_s \int_0^L f_s dL \quad (4)$$

$$Q_{bu} = q_{bu} A_b \quad (5)$$

where

D_s = diameter of shaft, ft

f_s = average skin friction, tsf

dL = increment of shaft length, ft

q_{bu} = ultimate base resistance pressure, tsf

A_b = base area, ft²

Equation 3 may not be realistic in overconsolidated clays since the skin friction usually decreases after a certain amount of deflection before the ultimate end bearing resistance is reached. This limitation is discussed later.

42. The skin friction is given by (Vesic 1977)

$$f_s = c_a + \beta \sigma'_v \quad (6)$$

where

c_a = soil adhesion, tsf

β = lateral earth and friction angle factor

σ'_v = effective vertical stress, tsf

43. The ultimate base resistance pressure is given by (Vesic 1977)

$$q_{bu} = cN_c + N_q \sigma'_v \quad (7)$$

where

c = soil cohesion (strength intercept) for 3 base diameters below bottom of base, tsf

N_c, N_q = dimensionless bearing capacity factors for cohesion and overburden, respectively

σ'_v = effective soil vertical pressure at the base of the shaft, tsf

The dimensionless bearing capacity factors are related to each other by (Terzaghi and Peck 1967, Vesic 1977)

$$N_c = (N_q - 1) \cot \phi' \quad (8)$$

where ϕ' is the effective angle of internal friction. The c and ϕ' parameters represent mean values for three diameters beneath the base of the shaft. Vesic (1977) suggests that since the N_q factors for driven piles in ordinary quartz sands of alluvial and marine origin do not exceed those for shallow square footings, a good approximate formula for N_q is

$$N_q = (1 + \tan \phi') e^{\tan \phi'} \tan^2 \left(45 + \frac{\phi'}{2} \right) \quad (9)$$

These values for N_c and N_q are shown as a function of ϕ' in Figure 5.

44. Vesic's N_c and N_q factors are conservative with respect to Meyerhof's (1955) factors also shown in Figure 5. Meyerhof's factors, which are similar to Terzaghi's factors (1943), assume a full shear surface and complete shear failure. In a homogeneous soil, the larger (less conservative) bearing capacity factors may not be applicable since the shearing stresses in the soil above the base of the shaft may alter the assumed shear pattern. The ultimate resistance also does not increase with depth in proportion with the depth of the soil beyond a depth of four or five shaft diameters. The actual effective vertical pressure σ'_v appears to remain roughly constant for depths greater than about

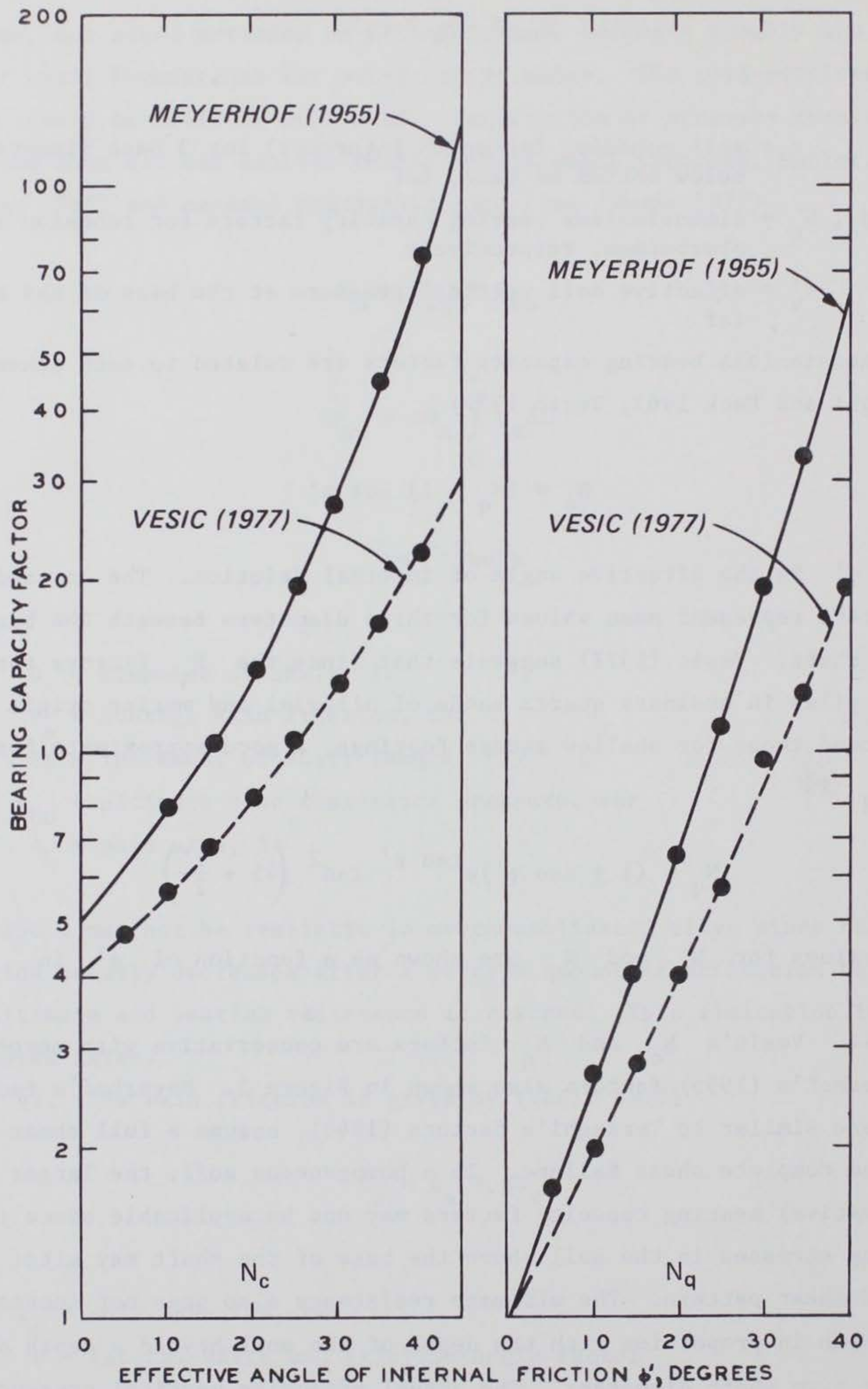

Figure 5. Bearing capacity factors N_c and N_q (Meyerhof 1955, Vesic 1977)

15 shaft diameters and depend only on ϕ' (Terzaghi and Peck 1967). Vesic (1977) suggests that the point resistance may well be governed by the mean normal effective ground stress σ'_m rather than the effective vertical stress and provides equations for using the mean normal stress. These equations, however, require the average volumetric strain in the plastic stressed zone around the base of the shaft, a quantity apparently not easily determined.

45. The skin friction term of Equation 6 for total stress analysis becomes

$$f_s = c_a = \alpha c_u \quad (10)$$

where

α = reduction factor, mobilized shear resistance/undisturbed shear strength

c_u = undrained shear strength, tsf

The ultimate point resistance of Equation 7 becomes

$$q_{bu} = 9c_u + \sigma'_v \quad (11)$$

The bearing capacity factor N_c is nine below a depth of four or five shaft diameters. The c_u is the undrained shear strength within three diameters beneath the base of the shaft. Skempton's (1951) values for N_c may be used for very shallow or short shafts. The N_q term in Equation 7 is usually ignored to compensate for the weight of the shaft.

46. The reduction factor α is a consequence of the reduction in soil strength due to soil disturbance and softening (or deterioration) and localized dissipation of negative pore water pressure (suction) due to sorption of moisture from the setting concrete or from other sources. The α had been proposed to decrease with increasing undrained strength (Tomlinson 1957) on the basis of limited data, but (Wright and Reese 1979) shows that α may be independent of strength and is less than one when the mobilized shear resistance is compared with the in situ shear strength of the soil adjacent to the shaft following installation. Table 2 shows that most methods for estimating α for drilled shafts by different investigators are similar and appear to follow that originally suggested by Skempton (1959). α is negligible near the top due to disturbance and low lateral pressures and also negligible near the base due to

mechanical interaction of stresses between the shaft and the base soils (O'Neill and Reese 1972). These effects may be considered by reducing the length of the shaft L used in Equation 4 by one shaft diameter below the ground surface and one shaft diameter above the base on the underream (Reese and Wright 1977). An α of about 0.6 is usually recommended where adequate local experience is available, but is reduced to about 0.3 when little is known about the soil or an underream is used (Tomlinson 1975). α may approach zero if the soil beneath the shaft footing is stiffer than the soil adjacent to the shaft or slurry is trapped at the shaft-soil interface (Reese, Touma, and O'Neill 1976). The Reese, Touma, and O'Neill (1976) recommendations are the most conservative of the methods listed in Table 2. From review of the available data, the α factor may be approximated by a simple sine function as follows

$$\alpha = \alpha' \sin \frac{z}{L} \pi \quad (12)$$

where

α' = factor for clay consistency (0.4 to 0.8 for stiff clay, 0.8 to 1.0 for normally consolidated or soft clay)

z = depth, ft

L = shaft length, ft

The α for driven piles varies between 0.2 and 1.0, but can be greater than the α for drilled shafts ($\alpha > 0.6$) if the depth is longer than $20 D_s$ and the undrained shear strength is less than 1 tsf (Tomlinson 1977).

47. Table 2 also illustrates the concept of partial factors of safety to determine the working load Q_w from the ultimate skin Q_{su} and base Q_{bu} resistances. Reese and Wright (1977) have developed a detailed table of partial safety factors to arrive at an overall or control factor of safety. The control factor of safety should be applied to the ultimate resistance Q_u to determine Q_w depending on the relative control or amount of scatter in the information associated with a given design parameter.

48. Effective stress analyses may be preferable because shear is confined to a thin zone around the shaft where drainage can take place rapidly (Burland 1973, Meyerhof 1976). Construction also disturbs the soil adjacent to the shaft. For effective stress analyses,

$$f_s = \beta \sigma'_v \quad (13)$$

$$q_{bu} = N_q \sigma'_v \quad (14)$$

where σ'_v is the effective vertical overburden pressure disregarding any effects from the shaft. The soil adhesion c_a in Equation 6, assumed as the effective cohesion, is zero for uncemented or remolded soil. β is given as a function of the effective friction angle ϕ' and coefficient of lateral pressure K . β is often difficult to determine, particularly for overconsolidated soil. The pore pressure must also be known to evaluate effective vertical pressure.

49. Table 3 shows that β increases with ϕ' , particularly for stiff (overconsolidated) clays. For soft or medium clays, more than 80 percent of the available field load data indicate β is between 0.25 and 0.40 for driven and drilled shafts (Burland 1973, Meyerhof 1976). A comparison of three methods for estimating β in soft clays (Figure 6) shows that Meyerhof's (1976) method is the most conservative and safest for design if field load test data are not available. The Burland (1973) and Parry and Swain (1977a) methods are less conservative and may be used if some field load test data are available to confirm the capacity predictions.

50. A comparison of several methods for estimating β of drilled shafts in stiff clays (Figure 7) shows that Meyerhof's (1976) method is too conservative. Chandler (1968) recommends that β should be 0.8 for conservative design. Hui's (1977) method will lead to estimates of β less than 0.8 for most cases. Esrig et al. (1978) and Chandler's (1968) methods may be used if reasonable estimates of both K_o and ϕ' can be made and some field load data or local experience is available to confirm the capacity predictions.

51. Elastic analysis. Elastic analysis improves on limit analysis by permitting computation of a linear load-deflection curve. Although elastic analysis is not usually used in design, it is of academic interest and may be useful for estimating the load-deflection behavior within the range of normal working loads Q_w . The slope of the linear

Table 3

Lateral Earth and Friction Angle Factor for Limit Analysis

Method	Lateral Earth and Friction Angle Factor β	Comments
Burland (1973) Chandler (1968)	$(1 - \sin \phi') \tan \phi'$; $0.25 < \beta < 0.40$; $\beta \approx 0.32$ $K_o \tan \zeta$; $\beta \approx 0.8$ for conservative design	Normally consolidated (NC) clays Overconsolidated (OC) clays
Parry and Swain (1977a) Hui (1977)	$\frac{\sin \phi' \cos \phi'}{1 + \sin^2 \phi'}$ or $\frac{\tan \phi'}{1 + \tan^2 \phi'}$	NC clays; failure assumed on the soil-shaft interface. ϕ' = effective soil friction angle
Parry and Swain (1977b)	$\frac{\beta}{m} = \frac{\sin(\zeta + r)}{\csc \phi' - \cos(\zeta + r)}$, $\sin r = \frac{\sin \zeta}{\sin \phi'}$	OC clays, $m = 1$ for NC clays to $m = 2.5$ for overconsolidation ratio (OCR) of 12. Assumed failure not on soil-shaft interface. ζ = soil-shaft friction angle
32 Hui (1977)	$\tan \phi'$	OC clays; failure assumed on a horizontal surface
Meyerhof (1976)	$0.75(1 - \sin \phi') \tan \phi' \sqrt{\text{OCR}}$	
Flaate and Selnes (1977)	$\frac{(0.2L + 4)}{L + 10} \sqrt{\text{OCR}}$	L = shaft length, ft
Janbu (1978)	$S_v (\sigma'_v + c \cot \phi')$	σ'_v = effective vertical overburden pressure. Skin friction number S_v found from charts
Gardner (1977)	$\frac{(1 + \sin \phi_r)(1 - \sin \phi')}{1 + \sin^2 \phi_r c_u} (\text{OCR})^m \tan \phi'_r$	$m = 0.58(\text{PI})^{-0.12}$; ϕ'_r = remolded residual) effective friction angle; PI = plasticity index; c_u = undrained strength
Esrig et al. (1978)	$(1 + 2K_o) \frac{\cos \phi' \sin \phi'}{3 - \sin \phi'}$	K_o found from a chart of curves as a function of ϕ' , PI, and OCR

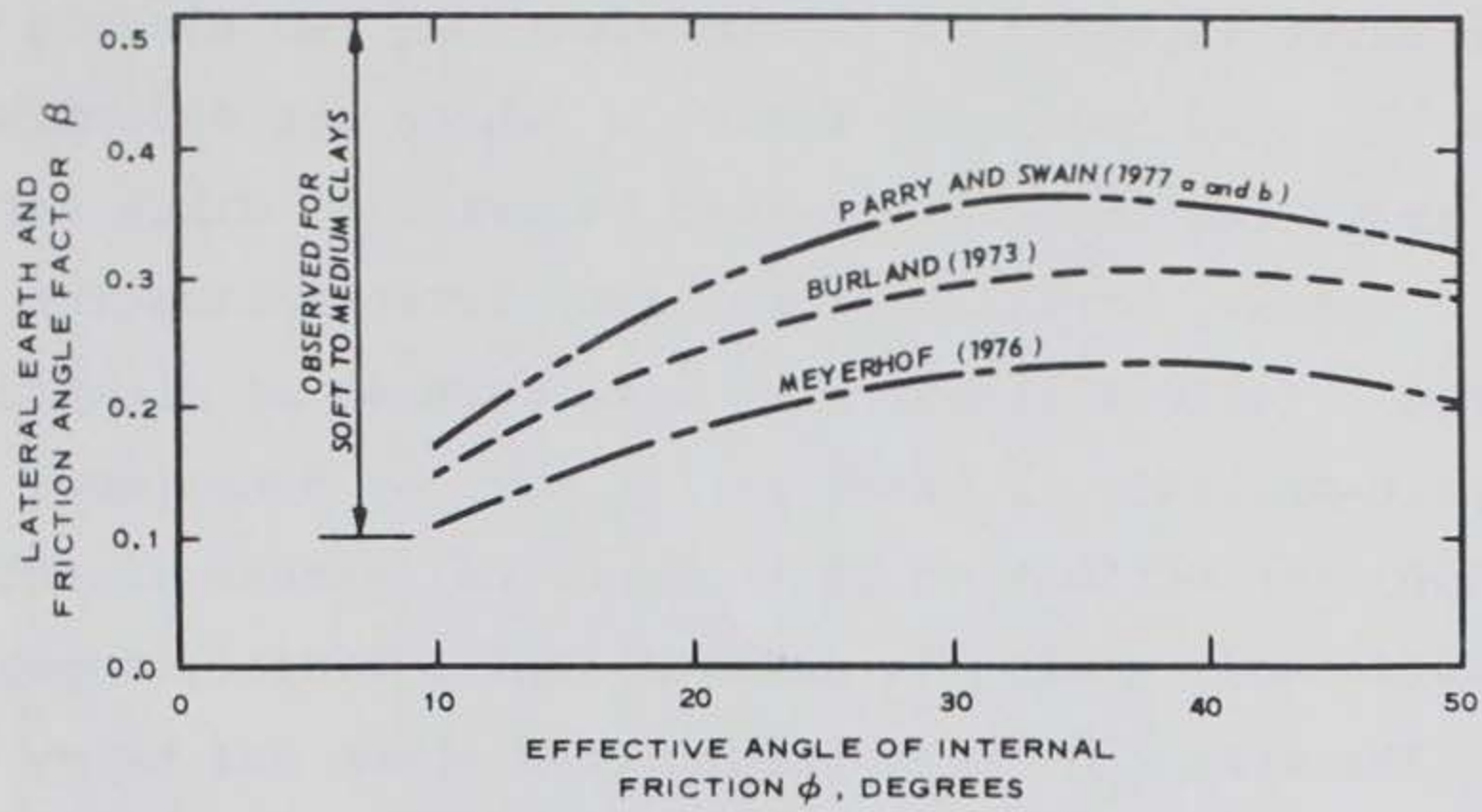

Figure 6. Comparison of methods for estimating β in soft to medium clays ($OCR = K_0 = 1$)

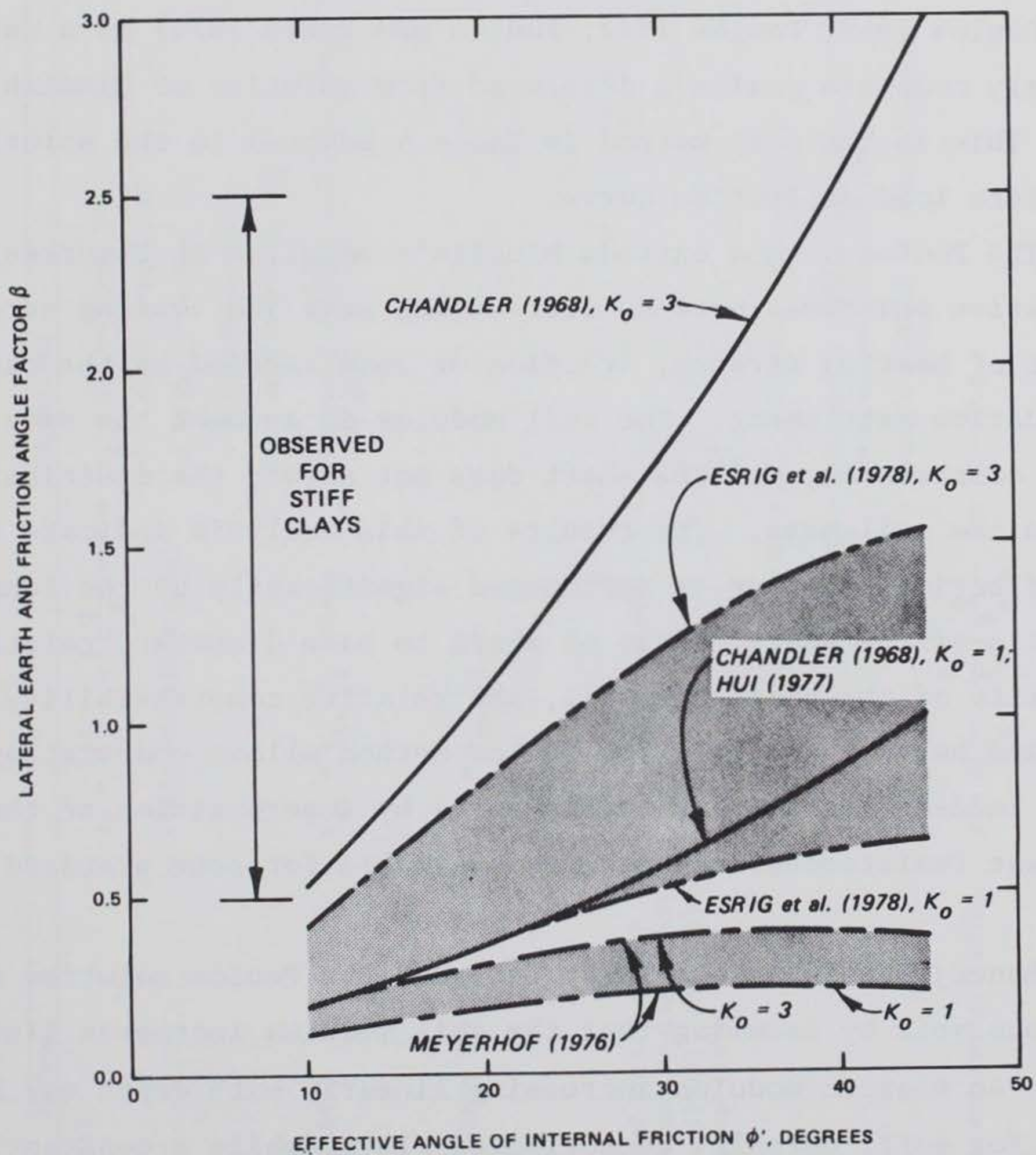

Figure 7. Comparison of methods for estimating β in stiff clays

load-deflection curve is based on the knowledge of two elastic constants, Young's modulus E_s and Poisson's ratio ν which are determined from undrained soil tests (assuming short-term behavior). Other variables such as state of stress, stress history, and overconsolidation ratio (OCR) are ignored. Table 4 illustrates some methods of elastic analysis.

52. Elastic analysis is based on the work of Boussinesq (1885) and Mindlin (1936) for estimation of the vertical stress distribution in soils. The elastic soil medium is assumed semi-infinite, homogeneous, and isotropic. The effect of load transmitted above and below the point of transfer is considered by Mindlin's equations as well as the influence of load transmitted from the shaft to the surrounding soil on settlement of soil beneath the base. The Poulos method (Poulos and Mattes 1969, Mattes and Poulos 1969, Poulos 1972, Poulos and Davis 1974) is a recent and relatively complete analysis developed from solution of Mindlin's equations. This is the only method in Table 4 adapted to the solution of the complete load-deflection curve.

53. The Poulos method extends Mindlin's solution to compressible shafts, relative stiffness between surrounding soil and bearing stratum, finite depth of bearing stratum, fraction of load carried by the base f , and consolidation settlement. The soil modulus is assumed the same in tension and compression, and the shaft does not affect the distribution of stress in the soil mass. The results of this analysis indicate that the load-deflection behavior is influenced significantly by the length/diameter ratio of the shaft, ratio of shaft to base diameter, relative compressibility of the shaft and soil, and relative compressibility of soil above and below the base. The Poulos method allows computation of a trilinear load-deflection curve (Figure 8) by superposition of the shaft and base resistances. Charts are available for some standard designs.

54. Banerjee and Davies (1978) extended the Poulos solution to nonhomogeneous soil by assuming that the soil modulus increases linearly with depth. An elastic modulus increasing linearly with depth may be appropriate for soft, normally consolidated clays, while a constant modulus may be appropriate for stiff, overconsolidated clays (Tomlinson 1977).

Table 4
Elastic Analysis

Method	Equations	Comments
Nair (1967)	$\rho_i = f\left(\frac{L}{r}, \nu\right) \frac{Q}{E_s r}$ where ρ_i = deflection, in. L = shaft length, ft r = shaft radius, ft ν = Poisson's ratio E_s = soil modulus, tsf (incompressible pile)	Adopts Mindlin's solution to cylindrical rigid shaft. Soil adjacent to the shaft adheres to the shaft and moves with the shaft. Charts available for analysis
Geddes (1969)	$\sigma_{zz} = k_{zz} \frac{Q}{L^2}$ where σ_{zz} = vertical stress, tsf at a point in the soil	Extends Boussinesq solution to load transferred by skin friction neglecting overburden. k_{zz} values given for uniform and linearly varying skin friction
Roy and Singh (1975)	$\sigma_{zz} = k_{zz} \frac{Q}{L^2}$	Extends Boussinesq solution to load transferred by skin friction accounting for shaft length and diameter and discontinuity in elastic medium due to shaft. Neglects radial stress. k_{zz} values given
Poulos and Mattes (1969), Mattes and Poulos (1969), Poulos (1972), and Poulos and Davis (1974)	$\rho_i = I \frac{Q}{E_s D_s}$ where $I = I_1 R_k R_h$ $I_1 = f\left(\frac{D_b}{E_s}, \frac{E_c}{E_s}\right)$ $R_k = \rho/\rho_i$ (compressible pile) R_h = settlement reduction factor for finite depth of soil correction E_c = Young's modulus of concrete, tsf	Extends Mindlin's solution to compressible, floating shaft and relative stiffness between the shaft, adjacent soil, and bearing stratum. Poisson's ratio of bearing stratum assumed equal to that of soil adjacent to shaft
Banerjee and Davies (1978)	$\rho = f\left(\frac{L}{D_s}, \frac{E_c}{E_s}\right) \frac{Q}{E_s D_s}$ for $\nu = 0.5$	Extends Mindlin's solution to nonhomogeneous soil assuming soil modulus increases linearly with depth. Charts available for straight and underreamed shafts
Randolph and Wroth (1978)	$\rho = f\left(\frac{L}{D_s}, \frac{E_c}{G_s}\right) \frac{Q}{G_s L}$ where G_s = shear modulus, tsf	Approximate, closed-form equation developed assuming shearing of concentric cylinders and punching shear at the base

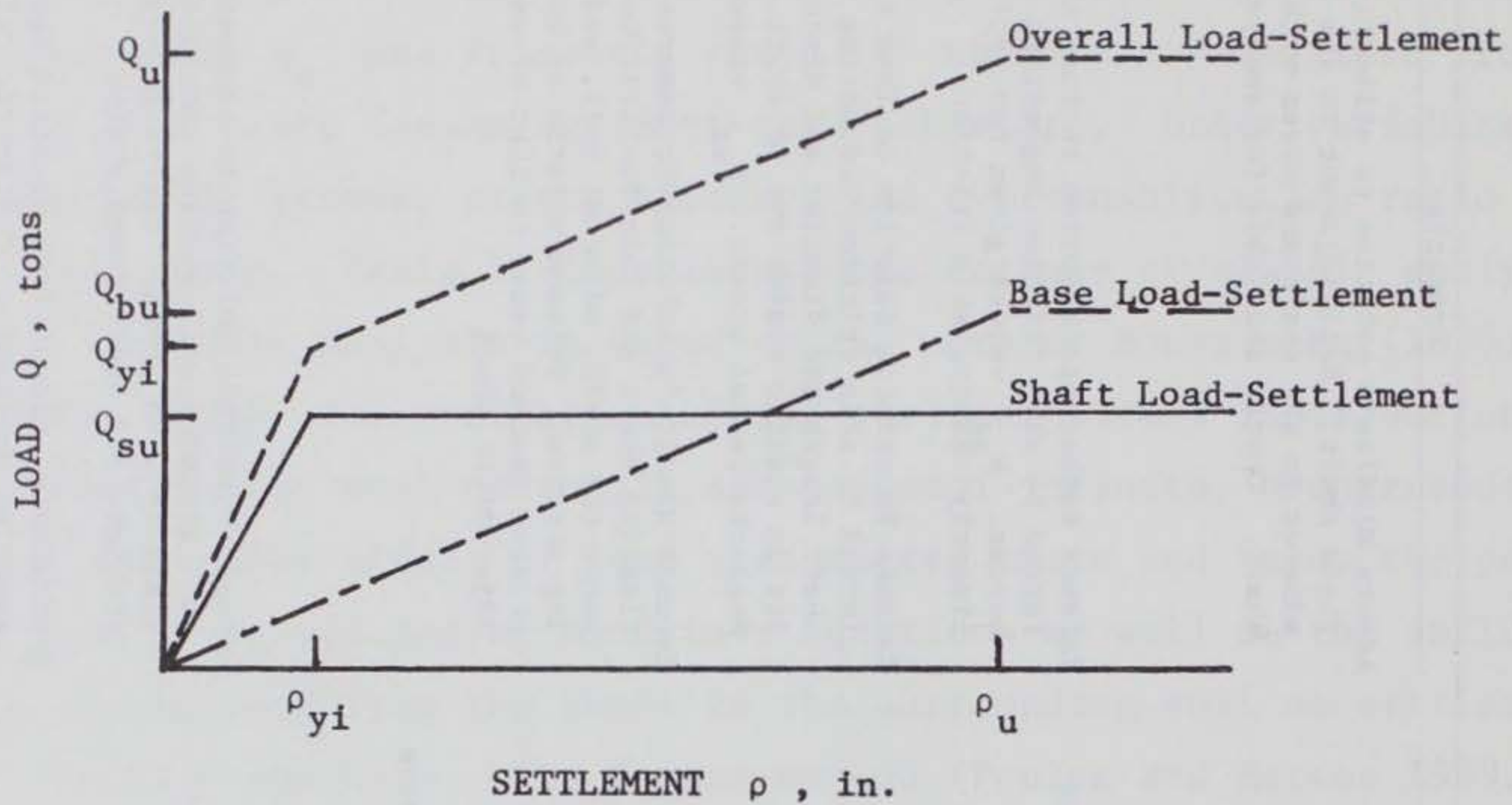

Equations	Definitions of Terms
$Q = Q_s + Q_b$	Q = load on shaft, tons
$Q_s = Q(1 - f)$	Q_s = skin friction load, tons
$Q_b = Qf$	Q_{su} = ultimate skin friction load, tons
$Q_u = Q_{su} + Q_{bu}$, $0 < Q_s < Q_{su}$ $0 < Q_b < Q_{bu}$	Q_b = end bearing load, tons Q_{bu} = ultimate end bearing load, tons
$\rho_s = \frac{I}{E_s D_s} \frac{Q_s}{1 - f}$, $0 < \rho_s < \rho_{yi}$	I = influence factor ρ_s = settlement of shaft due to load carried by shaft
$\rho_b = \frac{I}{E_s D_b} \frac{Q_b}{f} + \left(Q_b - \frac{Q_{su} f}{1 - f} \right) \frac{L}{A_b E_c}$, $0 < \rho_b < \rho_{bu}$	f = fraction load carried by end bearing ρ_b = settlement of shaft due to load carried in end bearing
$\rho_u = \frac{I}{E_s D_s} \frac{Q_{bu}}{f} + \left(Q_{bu} - \frac{Q_{su} f}{1 - f} \right) \frac{L}{A_b E_c}$	$Q_{yi} = \frac{Q_{su}}{1 - f}$, $\rho_{yi} = \frac{I}{E_s D_s} Q_{yi}$ E_s = soil modulus, tsf E_c = Young's modulus of concrete, tsf A_b = area of base, ft ²

Figure 8. The Poulos method of determining load-settlement behavior of drilled shafts (Poulos 1972)

Randolph and Wroth (1978) developed an approximate closed-form equation using the shear modulus G_s and assuming displacement occurs by shear. The closed-form equation allows hand calculation without need of a computer as required by solutions using elastic analysis. Both the Poulos method and the Randolph and Wroth method have been checked with results of very limited field load tests and found to provide reasonable correlation between theoretical and measured behavior within normal working loads.

55. Transfer function analysis. Load transfer functions allow computation of nonlinear load-deflection behavior up to the ultimate bearing capacity. The distribution of load along the shaft is defined by (Seed and Reese 1957)

$$\frac{d^2 \rho_s}{dz^2} = \frac{\pi D_s}{E_c A_s} S_f \rho_s \quad (15)$$

where

$S_f \rho_s$ = shear resistance at depth z , tsf

ρ_s = shaft movement at depth z , in.

E_c = Young's modulus of the shaft, tsf

A_s = cross-sectional area of the shaft, ft^2

Equation 15 must be solved incrementally since the mobilized shear resistance S_f/ρ_s depends on movement of the shaft. S_f defines the shape of the load transfer function. Heterogeneous soils may be accommodated by using a different transfer function for each type of soil. Most transfer functions ignore the effect of load transmitted to soil above and below the point of transfer; however, this influence may be small (Reese and Allen 1977).

56. Figure 9 illustrates some load transfer functions. Other analytical transfer functions are given in Table 5. The simple Reese, Hudson, and Vijayvergiya (1969) function in Table 5 is also plotted in Figure 9a. The Holloway, Clough, and Vesic (1975) function based on the Duncan and Chang (1970) hyperbolic soil model was derived from results

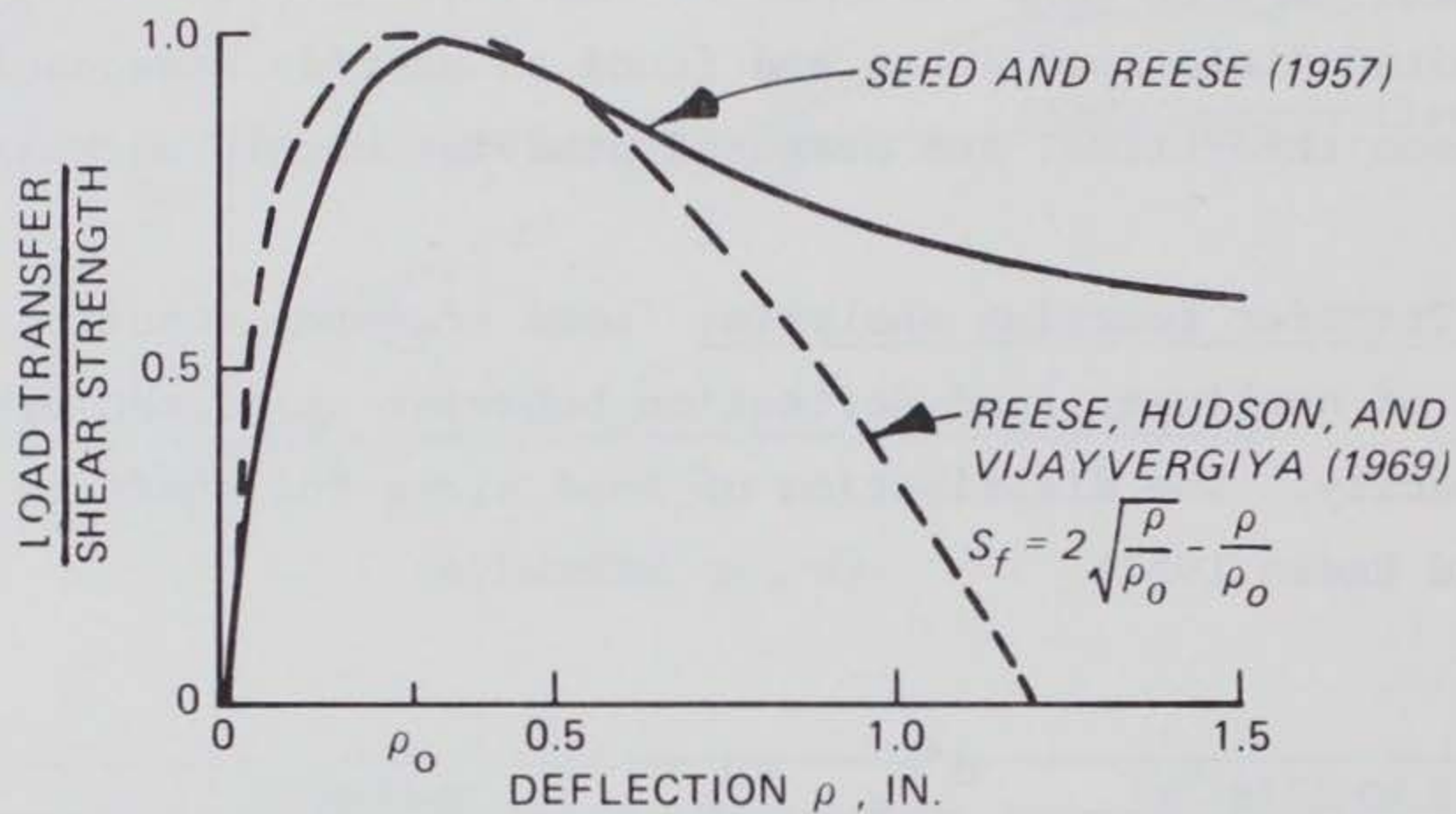

a. Transfer function for stiff clay

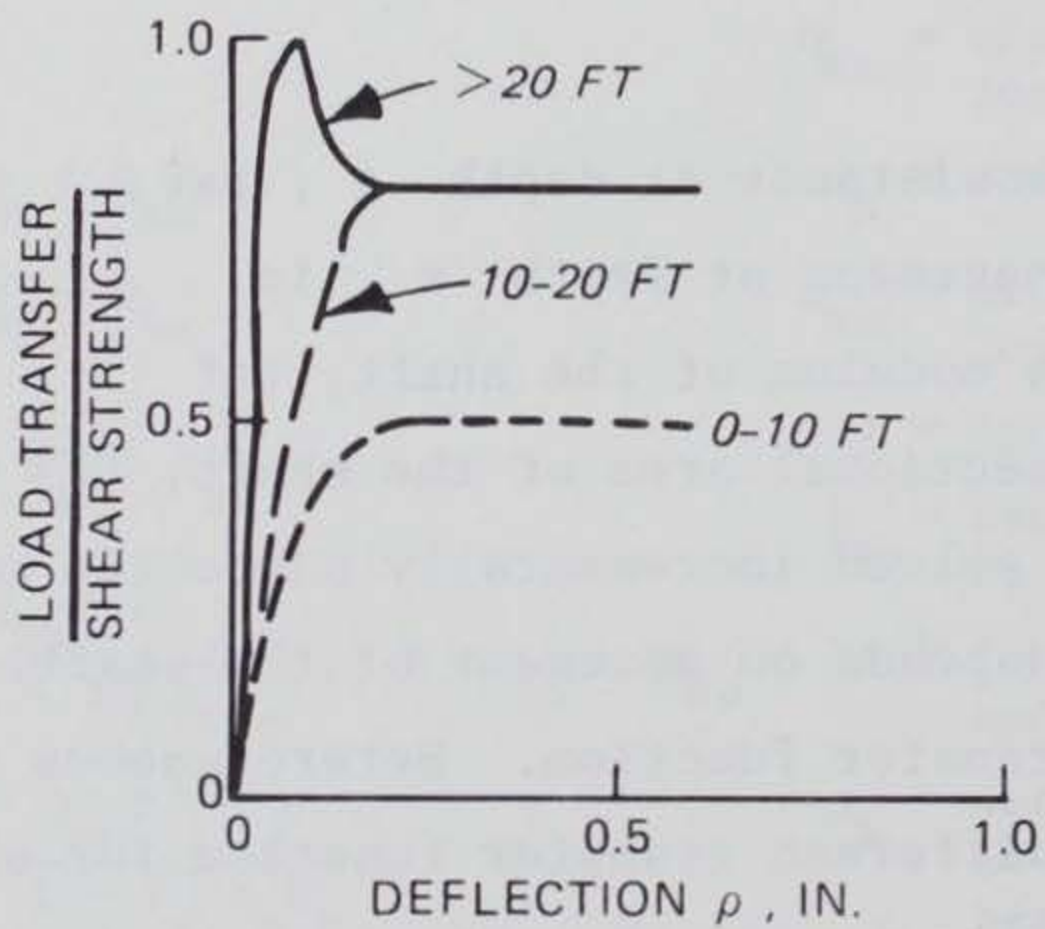

b. Transfer function with depth (Coyle and Reese 1966)

Figure 9. Load transfer functions

Table 5

Transfer Functions for Shaft Resistance

Method	Equations	Definitions of Terms
Kezdi (1957)	$f_s = K_o \gamma z \tan \phi' \left[1 - e^{(-k\rho/(\rho_{yi}^{-\rho}))} \right]$	<p>K_o = coefficient of lateral pressure</p> <p>γ = unit weight of soil, tons/ft³</p> <p>z = depth of soil, ft</p> <p>k = dimensionless function of slope of curve $f_s = f(\rho)$ at the origin</p> <p>ρ_{yi} = settlement at full mobilization, in.</p> <p>ρ = settlement at depth z</p> <p>ϕ' = effective friction angle</p>
Reese, Hudson, and Vijayvergiya (1969)	$f_s = K \left(2\sqrt{\frac{\rho}{\rho_o}} - \frac{\rho}{\rho_o} \right)$	<p>K = load transfer factor (1 for some stiff clays)</p>
Holloway, Clough, and Vesic (1975)	$f_s = K_{IS} \gamma_w \left(\frac{\sigma_3}{P_a} \right)^n \left(1 - \frac{\tau R_f}{\tau_s} \right)^2 \rho$	<p>K_{IS}, n, and R_f are factors of the hyperbolic formulation</p> <p>P_a = atmospheric pressure, tsf</p> <p>τ = shear stress at movement ρ, tsf</p> <p>τ_s = shear strength, tsf</p> <p>σ_3 = lateral confining pressure, tsf</p>
Williams and Colman (1965)	$f_s = \frac{2E_s \rho}{k_s D_s}$	<p>E_s = Young's modulus of soil, tsf</p> <p>k_s = constant ($1.75 < k_s < 5$)</p> <p>D_s = shaft diameter, ft</p>

of finite element analysis and therefore includes effects of load transmitted to soil above and below the point of transfer. None of the analytical expressions adequately represent the strain softening observed in stiff clays (Figure 9a).

57. Strain softening indicated in the transfer function curve for stiff clay (Figure 9a) is based on results of laboratory tests. If the applied load Q_w is such as to cause the ultimate shaft resistance Q_{su} to be mobilized, then any additional long-term settlement such as from creep or consolidation of the end bearing stratum may reduce the ultimate shaft resistance. The lost resistance (load shedding) is expected to be taken up by the end bearing stratum resulting in some additional settlement. This readjustment in the distribution of loads and additional settlement may continue for many years. Therefore, limit analysis using Equation 3 may overestimate the ultimate capacity of stiff clays since the peak capacity of the skin resistance occurs at a smaller deflection than that of the base resistance and subsequently decreases. Very little information is available documenting such long-term field performance of drilled shafts. Wooley and Reese (1974) found that load shedding was insignificant for a shaft in overconsolidated clay of Houston, Tex., for applied loads less than one third of the ultimate capacity Q_u .

58. Reese (1964) developed a computer program to solve Equation 15 by finite difference approximation. Any shape of the transfer function can be input into the program. An updated version PX4C3, of the program, is available (Radhakrishnan and Parker 1975) which permits individual transfer functions for each type of soil.

59. Vijayvergiya (1977) developed the transfer function for base resistance-deflection behavior

$$\frac{q_b}{q_{bu}} = \left(\frac{\rho_b}{\rho_{bu}} \right)^{1/3} \quad (16)$$

where the ultimate settlement ρ_{bu} may be taken as a percent of the

base diameter (4 to 6 percent) and q_{bu} equals $9c_u$.

60. An analytical expression for the mean base resistance-deflection behavior from data provided by Reese and Wright (1977) (see their Figure 8.8) is

$$\frac{q_b}{q_{bu}} = 0.76 \left(\frac{\rho_b}{\rho_{bu}} \right)^{2/3} \quad (17a)$$

$$\rho_{bu} = 2D_b \epsilon_{50} \quad (17b)$$

where

D_b = base diameter, in.

ϵ_{50} = strain at one half maximum compressive strength (deviator stress) of clay in an undrained triaxial test, percent

Some values for ϵ_{50} of undisturbed samples provided by Skempton (1951) are

<u>Clay Consistency</u>	<u>ϵ_{50}, percent</u>
soft	2.0
medium	1.0
stiff	0.7
hard	0.5

Comparison of results from Equations 16 and 17 shown in Figure 10 indicates that the Vijayvergiya relationship is likely to be too steep and allow too much end bearing at small deflections for most clays. A larger exponent in Equation 16 such as 1/2 or 2/3 may be more appropriate.

61. Williams and Colman (1965) developed a base transfer function

$$q_b = \frac{2E_{sb}}{k_b D_b} (\rho_b)^{2/3} \quad (18)$$

where

E_{sb} = Young's modulus of soil beneath the base, tsf

D_b = base diameter, ft

k_b = constant ($1 \leq k_b \leq 5$) from available data, ft^{-1}

The exponent of the base deflection ρ_b is identical with that provided by the mean of the Reese and Wright (1977) data (Equation 17). Assuming that q_{bu} is $9c_u$ and E_s is about $100c_u$, but no larger than $1000c_u$, the ultimate base deflection will vary between 1 and 10 percent of D_s for k_b between 1 and 5, respectively. These assumptions will cause the base transfer function of Equation 18 to overlap that for clays of hard to soft consistency (Figure 10). The assumption of $100c_u$ for E_s is shown later (paragraph 84) to match laboratory determined soil modulus for soils of several test sites.

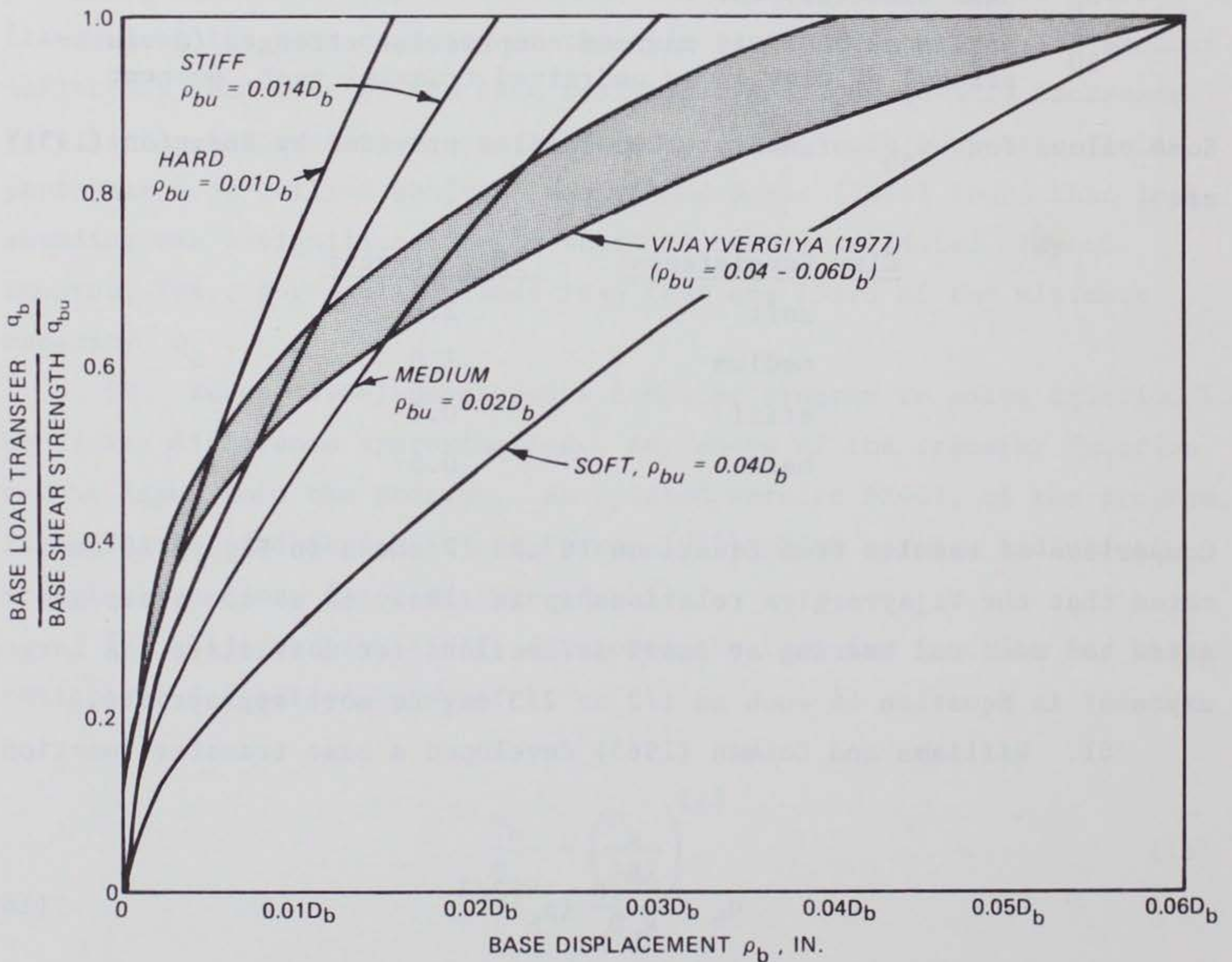

Figure 10. Comparison of base load transfer relationships

62. Finite element analysis. The finite element method can overcome disadvantages of the previous methods, but it is limited by the accuracy of constitutive relationships, availability of detailed laboratory test data, and the current state of knowledge on the behavior of soil and soil-structure interaction effects. Application of this method has been simplified for relatively simple geometric and boundary conditions by interactive graphic techniques and mesh generation subroutines. Trained personnel, however, are required to use the method, and results have not been adequately evaluated and compared with field performance to assure reliability for practical design cases.

63. Ellison, D'Appolonia, and Thiers (1971), Desai (1974), and Holloway, Clough, and Vesic (1975) have developed finite element programs to analyze single deep shafts. The Ellison program uses a tri-linear stress-strain curve, while the Desai and Holloway, Clough, and Vesic programs use the hyperbolic stress-strain model developed by Duncan and Chang (1970). These simple constitutive relationships do not consider the dilative, compressive, or strain softening nature of soil.

Downdrag loads
from consolidating soil

64. Shaft foundations in compressible cohesive soils can be subject to additional downdrag forces or negative skin friction caused by downward movement of soil relative to the shaft such as from consolidation of the surrounding soil. Consolidation can occur from surcharge effects of overlying fill, lowering of the groundwater level, remolding and reconsolidating soil during and following construction (primarily a problem with driven shafts), and surcharge from nearby shallow footings of newer structures (Harrington 1977). Consolidation of fills in which shafts are placed also contributes to downdrag loads. Consolidation can be especially damaging to battered shafts apparently because bending is aggravated from unbalanced forces and movement of soil away from the lower side of the shaft. Downdrag of drilled shafts in stiff clays is usually small or negligible because the magnitude of compression is small and tends to occur very slowly (Tomlinson 1975).

65. It should be noted that the sampling and testing techniques

tend to result in lower shear strengths and greater consolidation. These factors provide an unknown and unaccounted factor of safety with respect to bearing capacity analysis. However, the opposite is true with respect to computation of downdrag and heave effects such that downdrag loads and heave may be underestimated.

66. Negative skin friction. Negative skin friction f_n at the soil-shaft interface transfers load Q_n to the shaft

$$Q_n = \pi D_s \int_0^{L_n} f_n dL \quad (19)$$

where L_n is the thickness of soil down to the neutral point. Figure 11

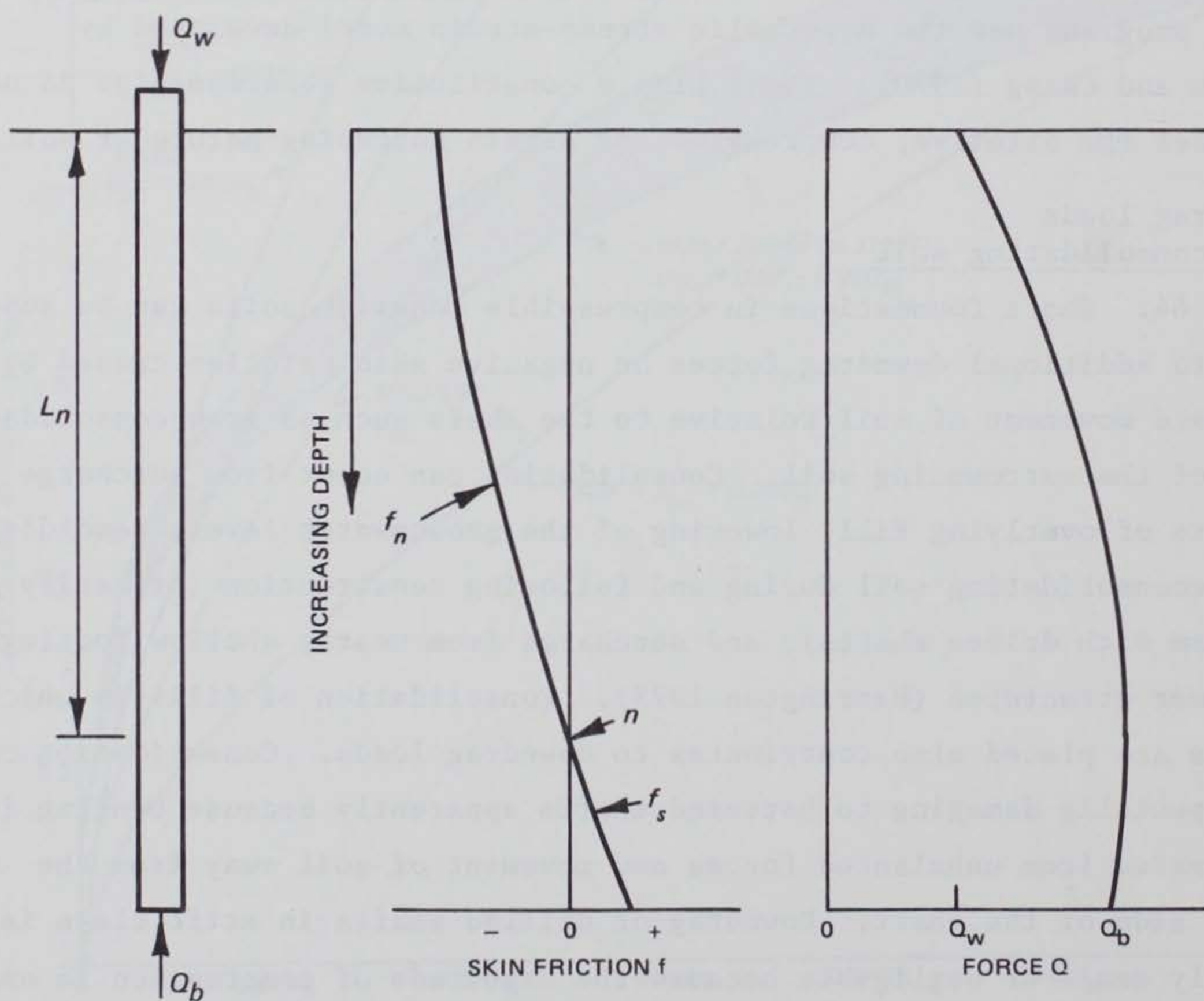

Figure 11. Distribution of load from negative skin friction

indicates that f_n has a maximum value at the upper portion of the shaft and becomes zero at the neutral point where no relative movement exists between the soil and the shaft.

67. The neutral point is the location of the maximum accumulated downdrag force. Positive skin friction occurs below the neutral point where the shaft moves down relative to the soil (Long and Healy 1974, Lambe, Garlanger, and Leifer 1974). The neutral point was located at a depth from two thirds to three fourths of the shaft length for shafts bearing on some compressible elastic soils (Ng, Karasudhi, and Lee 1976, Ito and Matsui 1976). Shafts bearing on increasingly stiff or rigid substratums such as hard shale or rock cause the neutral point and maximum downdrag force to shift closer to the base of the shaft. The length to the neutral point L_n may be taken as the full depth of the consolidating soil or the length of the shaft. L_n taken equal to the shaft length tends to provide conservative estimates or overestimates of the downdrag force. Some trial and error hand procedures for calculating the neutral point have been developed (Long and Healy 1974, Silva 1965).

68. The magnitude of f_n depends on the relative settlement of the soil with respect to the shaft and increases with increasing effective stress up to the shear strength of the soil (Horvat and Van Der Veen 1977, Harrington 1977, Lambe, Garlanger, and Leifer 1974). Other factors that influence f_n include stress history, mobilization of shear resistance at the soil-shaft interface, distribution of surcharge on the soil causing consolidation, stiffness of the bearing stratum, shaft compressibility, and method of installation (Kaniraj and Ranganatham 1977). Skin friction from downdrag appears to be somewhat less than that for positive skin friction; this is attributed to part of the soil weight being carried by the shaft.

69. A relatively small settlement is needed to mobilize the negative skin resistance; e.g., 70 percent of the maximum shear strength was mobilized in one case after a relative settlement between shaft and soil of 10 mm (Horvat and Van Der Veen 1977). For a Russian case, f_n decreased substantially after consolidation stopped (Bakholdin and Berman 1974). No explanation was offered; however, negative skin friction will

diminish if long-term settlement of the shaft or another field condition causes the shaft to move down relative to the soil.

70. Methods of analysis. Table 6 illustrates several limit and elastic methods for modeling the load behavior from negative skin friction. These methods are applicable to any type of shaft. The elastic methods are very similar to those described in Table 4 but are extended to soil consolidating adjacent to the shaft. Solutions of elastic methods are again limited to soil conditions provided in charts.

71. Long and Healy (1974) found that the Terzaghi and Peck (1967) and Garlanger (Lambe, Garlanger, and Leifer 1974) procedures were the most reasonable and straightforward of nine limit procedures for calculating the maximum f_n or maximum downdrag force. The Terzaghi and Peck method considers group action, while the remaining methods are applicable to single shafts with spacing/diameter ratios greater than four to eight. The Terzaghi and Peck method may provide larger estimates of downdrag force because a reduction factor is not used. However, omission of the reduction factor may tend to balance unconservative estimates of downdrag due to sampling and testing (paragraph 65). Downdrag for a group will usually be less than that for the same number of isolated shafts because of additional restraint to soil movement provided by the surrounding shafts. Garlanger's β for single shafts in clay is slightly less than that proposed by Chandler (1968) and Burland (1973) for positive skin friction to account for part of the soil weight hanging up or being carried on the shaft. Silva (1965) also developed a method using transfer functions for estimating load-deflection behavior.

72. The f_n can cause considerable downdrag force in addition to the applied axial load and may lead to excessive settlement or even bearing capacity failure (Lambe, Garlanger, and Leifer 1974). Structural failure of the concrete shaft is also possible, particularly for shafts bearing on hard shale or rock. Methods for reducing f_n on the upper portion of drilled shafts include casting in polyethylene, PVC, or bitumen-coated sleeves. Methods (Walker and Darvall 1973, Baligh and Vivatrat 1976) have been developed for estimating downdrag loads for

Table 6
Methods for Modeling Downdrag from Consolidating Soil

Method	Equations	Definitions of Terms/Comments								
<u>Limit</u>										
Harrington (1977)	$f_n = \beta \sigma'_v, \quad \beta = (1 - \sin \phi') \tan \phi'$ $Q_w = \frac{Q_{bu} + Q_{su} - Q_{ns}}{FS}$	Q_{su} = ultimate shaft resistance for positive skin friction Q_{ns} = ultimate shaft resistance for negative skin friction Q_{bu} = ultimate end bearing resistance Q_w = working load FS = factor of safety								
Garlanger (Lambe, Garlanger, and Leifer 1974)	$f_n = \beta \sigma'_v, \quad \beta = \beta_o K \tan \phi'$ <table style="margin-left: auto; margin-right: auto; border-collapse: collapse;"> <tr> <td style="text-align: center; border-bottom: 1px solid black;">β</td> <td style="text-align: center; border-bottom: 1px solid black;">Soil</td> </tr> <tr> <td style="text-align: center;">0.20-0.25</td> <td style="text-align: center;">Clay</td> </tr> <tr> <td style="text-align: center;">0.25-0.35</td> <td style="text-align: center;">Silt</td> </tr> <tr> <td style="text-align: center;">0.35-0.50</td> <td style="text-align: center;">Sand</td> </tr> </table>	β	Soil	0.20-0.25	Clay	0.25-0.35	Silt	0.35-0.50	Sand	β is back-figured from field test results β_o = reduction factor to account for part of soil weight carried by shaft K = coefficient of lateral earth pressure
β	Soil									
0.20-0.25	Clay									
0.25-0.35	Silt									
0.35-0.50	Sand									
Horvat and Van Der Veen (1977)	$f_n = c_a + K \tan \phi'$ $Q_w = \frac{Q_{bu} + Q_{su} - Q_{ns}}{2}$	K = 1.0 to 1.5								
Terzaghi and Peck (1967)	$Q_u = \frac{BHf_n}{n} + \frac{A\gamma_f H_f}{n}$	Accounts for group behavior B = perimeter of group H = thickness of consolidating layer H_f = thickness of fill f_n = average shear strength of consolidating soil A = area enclosed by outer perimeter of group γ_f = unit weight of fill n = number of shafts in group								
<u>Elastic</u>										
Ng, Karasudhi, and Lee (1976)	Load and settlement given as a function of time, depth, c_v , L/D , and E_c/E_s c_v = coefficient of consolidation L = length of shaft D = diameter of shaft E_c = modulus of shaft E_s = modulus of soil	Models circular, elastic rod embedded in homogeneous soil underlain by ideal elastic substratum of finite depth; uses one-dimensional Terzaghi consolidation theory. Charts available for standard designs								
Poulos and Davis (1974, 1975)	$Q = \frac{I_n E_s \rho_o L}{n}$	Charts available for standard designs I_n = influence coefficients; function of c_v , E_c/E_s , and time ρ_o = soil settlement at the surface								
Kaniraj and Ranganathem (1977)	Load and settlement given as a function of C_c , soil surcharge, and depth. C_c = compression index	Shear strength increases linearly with depth for a rigid bearing stratum and rigid shaft								

bitumen-coated shafts using results from laboratory shear tests.

Pullout loads

73. Foundations of some structures such as towers, tall buildings, and drilling platforms are subjected to uplift or pullout forces from tensile (upward), eccentric, or wind loads. The effect of these forces on the performance of the structure may be very significant and should also be considered for proper design. Results from several field and laboratory studies have shown that the pullout resistance of plate anchors Q_r can be approximated in cohesive soils, neglecting suction, using (Meyerhof and Adams 1968, Davie and Sutherland 1977)

$$Q_r = (c_u F_c + \gamma L) A_p \quad (20)$$

where

c_u = undrained shear strength, tsf

F_c = pullout resistance factor

γ = unit weight of soil, tons/ft³

L = embedment depth of the anchor, ft

A_p = cross-sectional area of the plate, ft²

Rapidly applied pullout forces can cause significant added restraint from suction (Beard and Lee 1975).

74. The pullout resistance factor F_c was found to be similar to the bearing capacity factor N_c for deep foundations under compressive loading (Kulhawy, Sangrey, and Clemence 1978)

$$2 \frac{L}{D} \leq F_c \leq 4 \frac{L}{D} \leq 9 \quad (21)$$

where D is the diameter or width of the plate. The maximum F_c is about nine or equivalent to N_c . The terms c_u and F_c in Equation 20 are usually much more significant than the γL term. Equations 20 and 21 are also applicable to underreamed drilled shafts. Ismael and Klym (1978) showed that no load transfer occurred along the shaft-soil interface during a pullout test of a 17-ft-long, 5-ft-diam shaft with a 10-ft-diam bell.

75. The pullout resistance of a cylindrical shaft with no underream in cohesive soil may be given by (Tomlinson 1977, Meyerhof and Adams 1968)

$$Q_r = \pi D_s \int_0^L f_s dL + \gamma_c L \frac{\pi}{4} D_s^2 \quad (22)$$

where

$f_s = \alpha c_u$, or pullout skin resistance, tsf

$\gamma_c =$ unit weight of concrete, tons/ft³

Ismael and Klym (1978) showed that significant load was transferred to the soil during a pullout test on a 38-ft-long, 5-ft-diam drilled shaft leading to an α of 0.64, which is in the range of α determined for normal loading as well as uplift thrust from swelling soils (paragraph 76). Figure 12 illustrates the distribution of load on a straight shaft from a pullout force. Comparison of Equations 20 and 22 shows that the underreamed shaft with shaft diameter D_s ($D_b > D_s$) tends to have greater pullout resistance than a straight shaft of the same diameter D_s ($D_b = D_s$) provided that the L/D_s ratio is less than five.

76. The drained or long-term pullout capacity in clay can be appreciably less than the undrained or short-term capacity, if soil wetting occurs dissipating suction and softening the soil. A cyclic pulling force such as from winds may lead to progressive (cumulative) uplift movement (Kulhawy, Sangrey, and Clemence 1978). Uplift produces a local decrease in the mean normal stress in some of the soil surrounding the anchor. The combination of the cyclic shear and cyclic decrease in the mean normal stress appears especially severe from available data. Sensitive cohesive soils can also experience major strength loss during cyclic loading, thus reducing pullout capacity.

Uplift loads from swelling soil

77. Shaft foundations are subject to uplift forces if the surrounding cohesive soil should swell and move up relative to the shaft. Swelling can occur in some soils if surface moisture seeps into soil

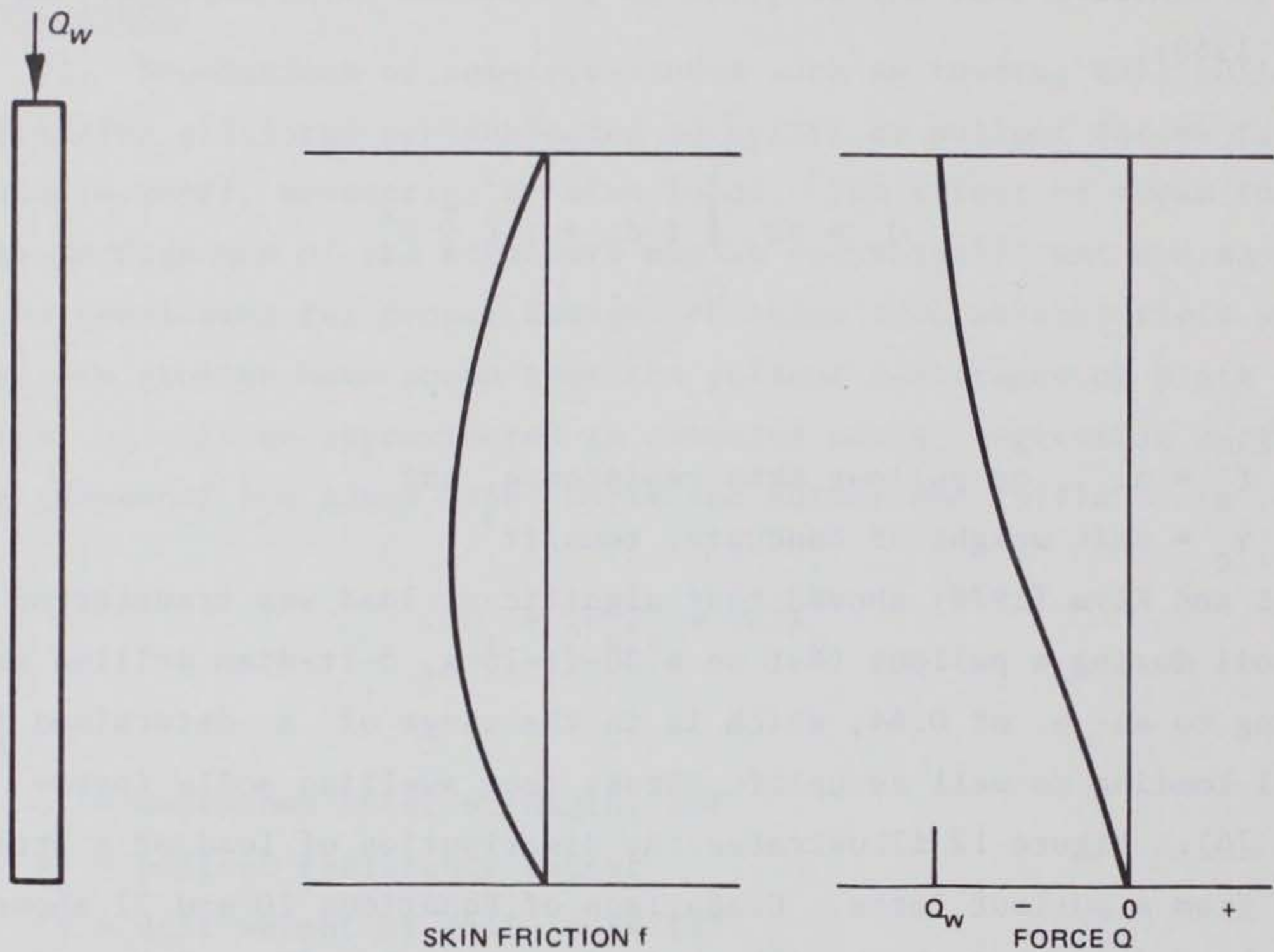

Figure 12. Distribution of load from a pullout force on a straight shaft

adjacent to the shaft. Moisture may also seep into soil below the base of the shaft, perhaps by migration down the soil-shaft interface or from a subsurface aquifer disrupted by construction. In swelling soils, this will contribute to the upward displacement of the shaft. The bearing capacity of most soils will be reduced if moisture seeps into soil beneath the shaft.

78. The uplift force can cause a net tension stress in the shaft and may cause it to fracture if not adequately reinforced. The shaft may also be uplifted if forces restraining upward movement are exceeded. The maximum upward thrust Q_{su} (Figure 13) is given by

$$Q_{su} = \pi D_s \int_0^{L_n} f_s dL \quad (23)$$

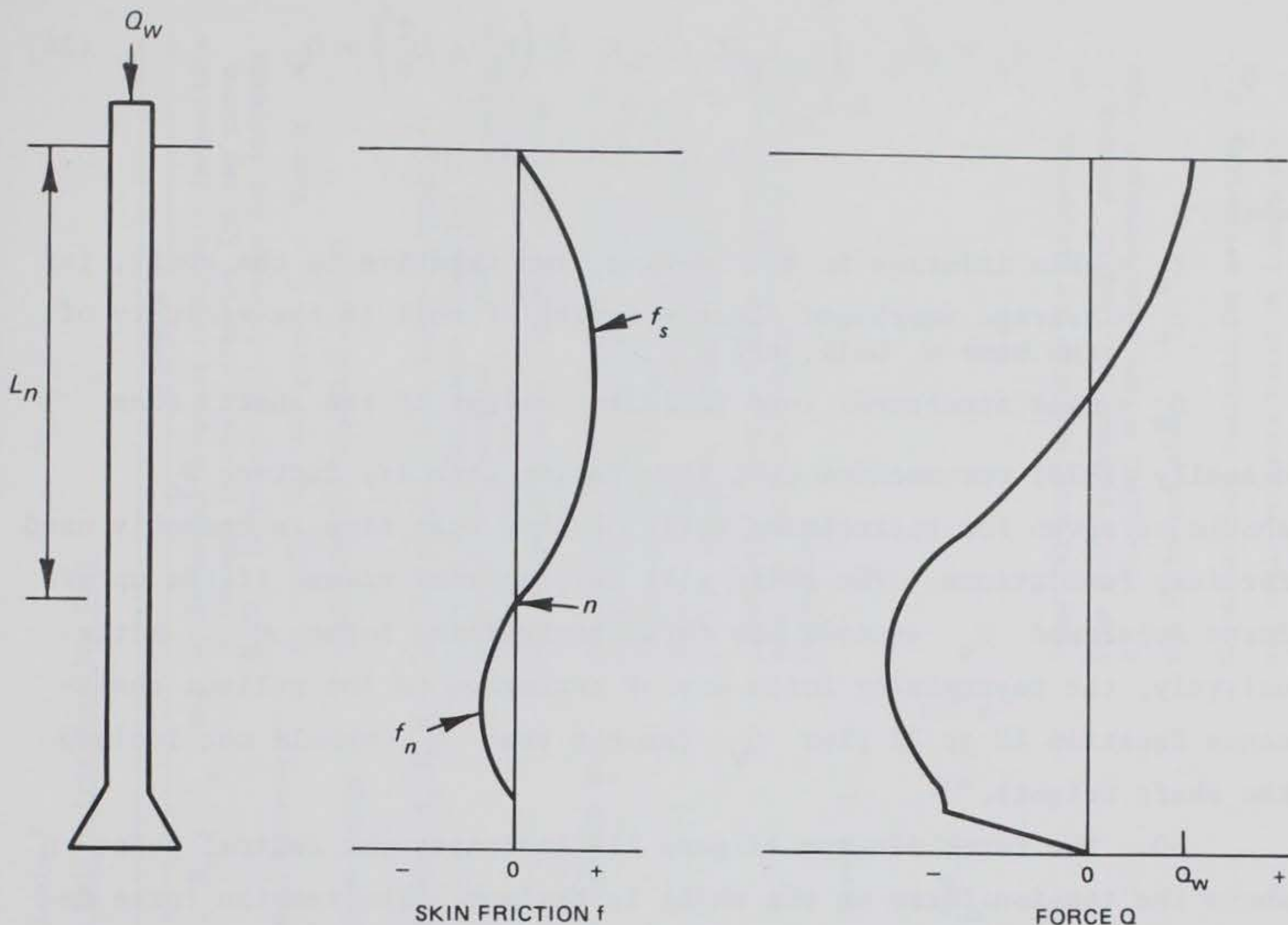

Figure 13. Distribution of load from upward thrust of swelling soil

where L_n is the thickness of the swelling layer moving up relative to the shaft. The skin friction f_s is similar to that in Equation 10 or 13. The reduction factor α in Equation 10 for upward thrust varies between 0.3 and 0.8, while β in Equation 13 is given as $K \tan \phi'$ where K varies between 1.0 and 2.0 (Donaldson 1967, Poulos and Davis 1973, Collins 1953). The skin friction that develops depends on the relative displacement between the soil and shaft and consequently is a function of the change in effective stress or reduction in swelling pressure that results from expansion of the surrounding soil.

79. One proposed equation for the force Q_r restraining the upward thrust is given by

$$Q_r = \pi D_s \int_{L-L_n}^L f_n dL + C_u N_c \frac{\pi}{4} (D_b^2 - D_s^2) + Q_w \quad (24)$$

where

f_n = skin friction in soil moving down relative to the shaft, tsf

c_u = average undrained shear strength of soil in the vicinity of the base or bell, tsf

Q_w = dead structural load including weight of the shaft, tons

McAnally (1973) recommended that the bearing capacity factor N_c should be seven for restraining uplift rather than nine as commonly used for deep foundations. The shaft will be displaced upward if the uplift force developed Q_s exceeds the total restraining force Q_r . Alternatively, the restraining force may be analogous to the pullout resistance Equation 20 or 22 plus Q_w (except that Q_w should not include the shaft weight).

80. The force diagram (Figure 13) indicates the neutral point n where the tension force on the shaft is maximum. The tension force decreases to zero at the base, although a significant tension load may occur at the intersection of the top of the enlarged base with the shaft. The maximum tension tends to increase if the shaft length or diameter of the underream increases such that the upward movement of the shaft is reduced (Poulos and Davis 1973). Conventional analyses (Collins 1953, Donaldson 1967, Johnson 1979) indicate that the axial load Q_w should be equal to the ultimate upward thrust Q_{su} to assure full suppression of any tension and upward movement, while Poulos and Davis (1973) calculated that an applied force equal to about one half of Q_{su} is adequate to suppress upward movement.

81. Table 7 illustrates several approximate methods for predicting the maximum tension load and upward movement as an aid to the design of drilled shafts in swelling soil. The methods of McAnally (1973), Poulos and Davis (1973), and Johnson (1979) provide estimates of maximum tension force and shaft movement for given shaft and base diameters and soil conditions, while the other methods provide estimates of the maximum

Table 7

Methods for Modeling Uplift from Swelling Soil

Method	Equations	Comments
McAnally (1973)	Q_{su} and $\Delta\rho =$ functions of D_s , D_b , c_a , and m_v $\Delta\rho =$ differential movement between shafts $m_v =$ coefficient of volume change	Differential movement relatively insensitive to changes in shaft diameter for any given D_b/D_s ratio but will increase for increase in D_b/D_s for any given D_s . Charts available for standard designs
Poulos and Davis (1973)	Q_{su} and $\rho =$ functions of soil heave, E_s , L , D_s , and D_b	Linear elastic model based on Mindlin's equations. Approximate allowance for variation of soil modulus. Considers slippage between shaft and soil. Charts available for standard designs and soil conditions
Johnson (1979)	Shaft movement will not occur for lengths of: $L = 2X_a - 1.42 \frac{D_b}{D_s}^{2.5} \quad \text{for } D_s = 1.5 \text{ ft}$ $L = 2X_a - 1.76 \frac{D_b}{D_s}^3 \quad \text{for } D_s = 3 \text{ ft}$ $X_a =$ active depth for soil heave, ft Percent steel reinforcement: $A_s = 0.0094 \frac{Lc_a}{D_s} + 0.00275 \frac{L^2 K \tan \phi'}{D_s} - 0.03 \frac{Q_w}{D_s^2}$	Approximate model based on dissipation of swell pressures. Slippage occurs between shaft and soil if swell pressure exceeds shear strength. Considers heterogeneous soils. Computes maximum tension C_{su} assuming shaft does not move. Provides upper limit to shaft movement. Computer program documented
Collins (1953)	$Q_{su} = \pi D_s \int_0^L (c + K \tan \phi') dL$	Graphical hand analysis for estimating Q_{su} from shaft diameter and length. Assumes Q_{su} equivalent to the shear strength times the perimeter area
Komornik and Zeitlen (1973)		Graphical hand analysis for estimating Q_{su} and swell pressure based on laboratory shear and swell pressure studies

tension force. The McAnally method can also provide an estimate of differential movement between shafts. The Poulos and Davis method is based on an elastic solution to Mindlin's equations for a known upward soil displacement. The above methods indicate that shaft movement may best be minimized by constructing a straight shaft with length twice the depth of the swelling soil or an enlarged base of sufficient diameter placed at a depth just below or at the bottom of the swelling soil stratum. The enlarged base is limited to soils that will hold the enlargement (will not cave) until the concrete is poured.

Lateral Load Behavior of Single Shafts

82. Drilled shaft foundations are often subject to lateral loading forces from winds on the superstructure, centripetal forces of vehicles moving over curved bridges or water flowing around supporting columns of bridges. Methods for determining the lateral load-deflection behavior of drilled shafts are based on solutions of the elastic beam column differential equation (Hetenyi 1946)

$$E_c I \frac{d^4 y}{dz^4} + Q \frac{d^2 y}{dz^2} - p = 0 \quad (25)$$

$$p = -E_s y \quad (26)$$

where

E_c = elastic modulus of the shaft, tsf

I = moment of inertia of the shaft section, ft^4

Q = axial load, tons

p = soil reaction per unit length, tons/ft

y = lateral deflection, ft

z = depth along shaft, ft

E_s = soil modulus of shaft reaction, tsf

No differentiation is made herein between the soil modulus of (lateral) shaft reaction and the (vertical) secant modulus found from results of triaxial undrained strength tests, for the purpose of simplifying

analyses. Differences may exist between these moduli, particularly in anisotropic soil, but the significance on shaft behavior is not well-documented.

83. Solutions of Equation 25 show that deflection and rotation of the shaft from lateral loads increase as the flexibility or L/D_s ratio increases and the elastic soil modulus decreases (Poulos 1971). Underreams appear to have very little effect on lateral resistance (Bhushan, Haley, and Fong 1978), except for extremely short shafts with bells. Costs can also be minimized by designing uniformly dimensioned shafts with larger diameters and shorter lengths (Farmer et al. 1978).

Soil modulus of reaction

84. The soil modulus of reaction E_s may be given in terms of the coefficient of horizontal subgrade reaction k_h

$$E_s = k_h D_s \quad (27)$$

where D_s is the shaft diameter. Terzaghi (1955) proposed for stiff clays

$$k_h = \frac{k_{s1}}{1.5D_s} \quad (28)$$

where k_{s1} is the coefficient of subgrade reaction for a 1-ft-square plate. k_{s1} was proposed to vary as shown in Table 8 for overconsolidated clay depending on consistency. According to these criteria and

Table 8

Coefficients of Subgrade Reaction k_{s1} Proposed by Terzaghi (1955)

<u>Clay Consistency</u>	<u>Stiff</u>	<u>Very Stiff</u>	<u>Hard</u>
c_u , tsf	1-2	2-4	>4
k_{s1} , tons/ft ³	50-100	100-200	>200
Proposed k_{s1} , tons/ft ³	75	150	300
E_s , tsf	50	100	200

Equations 27 and 28, E_s is about $34c_u$, where c_u is the undrained shear strength.

85. Davisson (1970) proposed that E_s should be about $67c_u$, while Banerjee and Davies (1978) proposed that E_s should vary between 100 and $180c_u$. Ottaviani and Marchetti (1979) found that the laboratory E_s was about $150c_u$ but that the field E_s was about $1000c_u$ or 7 times the laboratory E_s . McClelland and Focht (1956) found that the field E_s was about 11 times the secant modulus from results of laboratory triaxial CU tests confined at a lateral pressure of γz , where γ is the unit wet soil weight.

86. A comparison of modulus of subgrade reaction values predicted by the methods of Terzaghi, Davisson, and Banerjee and Davies is shown in Table 9 for laboratory data given by Bhushan, Haley, and Fong (1978).

Table 9
Comparison of Soil Modulus of Subgrade Reaction E_s *

Site	Average Undrained Strength c_u , tsf	Laboratory Soil Modulus E_s , tsf	Predicted E_s , tsf		
			Terzaghi (1955)	Davisson (1970)	Banerjee and Davies (1978)
A	2.75	292	94	184	275-495
B	2.37	330	81	159	237-427
C	2.30	255	78	154	230-414
E	5.00	1000	170	335	500-900

* Laboratory data taken from Bhushan, Haley, and Fong (1978).

The laboratory E_s determined from the average undrained strength c_u divided by ϵ_{50} (strain at 1/2 of the maximum deviator stress) is also shown in Table 9. This comparison shows that the Banerjee and Davies proposal for E_s (100 to $180c_u$) bounds or is within close range of the laboratory Young's soil modulus. The Terzaghi and Davisson proposals for E_s appear excessively conservative.

Solution of the beam column equation

87. The solution of Equation 25 depends on whether the shaft is

restrained or free to move at the top and whether the shaft is rigid (short and free to move at the bottom) or flexible (long and pinned at the bottom). Rigid analysis, which is simpler than flexible analysis when using hand calculation methods, is applicable for $L/D_s \leq 6$ (Woodward, Gardner, and Greer 1972, Kasch et al. 1977). Broms (1964) and Ismael and Klym (1978) observed that βL should be less than 1.5 for rigid analysis where

$$\beta = \frac{4 \sqrt{\frac{k_h D_s}{4E_c I}}}{1} \quad (29)$$

assuming k_h is constant. βL for flexible shafts should be greater than 2.5. The point of rotation for a rigid shaft is about two thirds of the embedment depth and moves down to at most three fourths of the embedment depth with increasing rotation (Holloway et al. 1978).

88. Table 10 illustrates subgrade reaction, elastic (or computer) applications, and $p - y$ curves for solution of the beam column differential equation. These methods can provide close prediction of bending moment within 10 to 20 percent, but predictions of deflection can be off by more than 50 percent, particularly at loads exceeding one half of the ultimate lateral load P_u . Reese and Allen (1977) provide additional details on various procedures for computing lateral load-deflection behavior.

89. Subgrade reaction. Solutions for a homogeneous soil profile based on subgrade reaction are easiest to apply following determination of an appropriate k_h or E_s . Calculations may be done manually and usually provide conservative estimates of a linear load-deflection behavior up to one third to one half of the ultimate load P_u or about 1/2 in. of lateral deflection. The Broms (1964) and Ismael and Klym (1978) methods assume a uniform soil with constant k_h .

90. Elastic deformation. The elastic or computer solutions for a homogeneous soil shown in Table 10 provide linear lateral load-deflection curves depending on the soil modulus E_s . The Holloway et al. (1978) method, based on the Hays et al. (1974) method, provides a design lateral

Table 10
Lateral Load Behavior of Single Shafts

Method	Equations	Definitions of Terms/Comments
Subgrade reaction k_h Broms (1964)	Short free head: ($\beta L < 1.5$) $y_o = \frac{4P \left(1 + 1.5 \frac{e}{L}\right)}{k_h D_s L}$ $\frac{P_u}{c_u D_s^2} = f \left(\frac{L}{D_s} \frac{e}{D_s}\right)$ Long free head: ($\beta L > 2.5$) $y_o = \frac{2P\beta(e\beta + 1)}{k_\infty D_s}$ Short fixed: $y_o = \frac{P}{k_h D_s L}$ $P_u = 9c_u D_s (L - 1.5D_s)$ Long fixed: $y_o = \frac{P}{k_h D_s}$ $P_u = \frac{2M_{yield}}{1.5D + 0.5f}$	y_o = groundline deflection, ft $\beta = \sqrt[4]{k_h D_s / 4E_c I}$ P = lateral load, tons e = distance above ground surface of P , ft L = length embedment, ft P_u = ultimate lateral load (found from charts), tons k_∞ = coefficient of subgrade reaction of infinitely long shaft M_{yield} = yield moment of shaft section, ft-tons $f = P/9c_u D_s$, distance $1.5D_s$ from ground surface to maximum bending moment, ft Provides good estimate of maximum bending moment (≈ 10 percent) because method is insensitive to small changes in c_u or distribution of lateral pressures For rigid shafts, $\beta L < 1.5$ β from Equation 29 or above k_h = constant y_o = groundline deflection 1/3 to 1/2 of P_u $P_u = 3c_u D_s$ at surface $P_u = 9c_u D_s$ at a depth of 2 ft and below
Ismael and Klym (1978)	$y_o = \frac{P(4L + 6e)}{k_h D_s L^2}$	

(Continued)

(Sheet 1 of 4)

Table 10 (Continued)

Method	Equations	Definitions of Terms/Comments
Computer (elastic) Matlock and Reese (1960)	$y = \left(\frac{PT^3}{E_c I} \right) A_y + \left(\frac{MT^2}{E_c I} \right) B_y$ $T = \sqrt[5]{\frac{E_c I}{n_h}}, \quad E_s = n_h z$ <p>Rigid free head: $L < 2T$ Flexible free head: $L > 4T$</p>	<p>Accounts for nonlinearity between p and y by iteration to adjust E_s for compatible soil and shaft deflections</p> <p>E_s related to depth only since E_s insensitive to deflection, bending moment, and shear</p> <p>M = moment at ground surface, in-lb P = lateral load at ground surface, lb</p> <p>A_y, B_y = coefficients from charts</p>
Poulos (1971)	<p>Free head: $y = I_{yp} \frac{P}{E_s L} + I_{ym} \frac{M}{E_s L^2}$</p> $I_{\theta p} \frac{P}{E_s L^2} + I_{\theta m} \frac{M}{E_s L^3}$ <p>θ = rotation, degrees y = lateral deflection, in.</p>	<p>Soil assumed ideal, elastic, homogeneous, isotropic mass with two soil properties of soil modulus E_s and Poisson's ratio = 0.5. Shaft assumed thin, rectangular vertical strip of width D_s, length L, and constant flexural stiffness $E_c I$</p> <p>Charts given for I_{yp} and I_{θ} as function of $K_r, L/D_s$ where $K_r = (E_c I)/(E_s L^4)$</p> <p>Solution for flexible shaft. From Mindlin equations for horizontal displacement due to a horizontal load P. E_s constant with depth</p>
Davisson (1970)	$y = \left(\frac{PT^3}{E_c I} \right) C_y$ <p>$M = PT C_m$</p>	<p>Solution for flexible shaft:</p> $T = \sqrt[5]{E_c (I/n_h)}$ <p>$E_s = n_h z$ $E_s \approx 67c_u$</p> <p>Charts available for C_y and C_m</p>
Kuhlemeyer (1979)	<p>Flexible free: $y = a_{11} \left(\frac{2P}{E_s D_s} \right) + a_{12} \left(\frac{4M}{E_s D_s^2} \right)$</p> $\theta = a_{21} \left(\frac{4P}{E_s D_s^2} \right) + a_{22} \left(\frac{8M}{E_s D_s^3} \right)$	<p>Results of finite element analysis where a_{ij} represents flexibility coefficients:</p> $a_{11} = 0.567 \left(\frac{E_c}{E_s} \right)^{-0.170}$ $a_{12} = a_{21} = 0.369 \left(\frac{E_c}{E_s} \right)^{-0.407}$

(Continued)

(Sheet 2 of 4)

Table 10 (Continued)

Method	Equations	Definitions of Terms/Comments
Kuhlemeyer (continued)		$a_{22} = 0.585 \left(\frac{E_c}{E_s} \right)^{-0.663}$ <p>Consistent with Poulos' (1971) solution. Poisson's ratio has little significance. Use computer program for nonhomogeneous soil</p>
Holloway et al. (1978)	<p>To limit rotation:</p> $P_\theta = \frac{P_r}{1 - \frac{(2.5 - \theta)^2}{6.25}}$ $P_{\text{design}} = P_\theta \cdot \text{FS}$	<p>P_r = resultant force transmitted from retaining wall to supporting shaft</p> <p>P_θ = lateral force at height e above ground surface</p> <p>θ = allowable rotation</p> <p>FS = 1/3 to 1/2 to limit creep</p> <p>P_u = greater than P_{design}. P_u found from Hays (1974) design charts</p>
Banerjee and Davies (1978)	$y = I_{yp} \frac{P}{E_s L} + \frac{I_{ym} M}{E_s L^2}$ $\theta = I_{\theta p} \frac{P}{E_s L^2} + \frac{I_{\theta m} M}{E_s L^3}$	<p>Axial load, horizontal load, and moment at shaft head related to vertical and horizontal displacement and rotation by set of 3 by 3 matrix flexibility equations. Charts available for I_v and I coefficients fixed of free head and free rotation. Soil modulus E_s increases linearly with depth $E_s \approx 100$ to $180c_u$</p>
Barber (1954)	$y_o = \frac{18P}{n_h D_s^2} - \frac{24M}{n_h D_s^3}$ $\theta = - \frac{24}{n_h D_s^3} P + \frac{36M}{n_h D_s^4}$	<p>$E_s = n_h z$ (soil modulus increasing linearly with depth provides groundline deflection and slope)</p>
<u>p - y curves (nonlinear)</u>		
Reese and Welch (1975)	$\frac{P}{P_u} = 0.5 \left(\frac{y}{y_{50}} \right)^{1/4}$	$P_u = \left(3 + \frac{\gamma z}{c_u} + 0.5 \frac{z}{D_s} \right) c_u D_s \text{ or } 9c_u D_s, \text{ whichever is smaller}$ $y = \left(\frac{2.5 D_s}{\epsilon_{50}} \right) \epsilon^2$

(Continued)

Table 10 (Concluded)

Method	Equations	Definitions of Terms/Comments
Reese and Welch (continued)		<p>where</p> <p>ϵ = strain from strength test</p> <p>ϵ_{50} = strain at 1/2 of c_u</p> <p>$y_{50} = 2.5D_s \epsilon_{50}$</p>
Bhushan, Haley, and Fong (1978)	$\frac{P}{P_u} = 2 \left(\frac{y}{y_{50}} \right)^{1/2}$	$P_u = \left(3 + \frac{y_z}{c_u} + 2 \frac{z}{D_s} \right) c_u D_s$ <p>$y_{50} = 2D_s \epsilon_{50}$</p>
Ismael and Klym (1978)	$\frac{P}{P_u} = 0.5 \left(\frac{y}{y_{50}} \right)^{1/4}$	<p>$P_u = 3c_u D_s$ at surface</p> <p>$= 9c_u D_s$ at depth 2 ft below</p>

load which must be less than P_u to maintain the rotation of a rigid shaft to within a tolerable angle. The computer solutions provide dimensionless coefficients given in a series of charts for some design cases. The Poulos (1971) and Kuhlemeyer (1979) methods assume a constant soil modulus (overconsolidated clays), while Matlock and Reese (1960), Davisson (1970), and Banerjee and Davies (1978) assume E_s may increase linearly with depth (normally consolidated clays). Poisson's ratio was found not to have any significant influence on results.

91. Figure 14 illustrates predictions of the lateral load-deflection behavior of several test shafts at the sites of the Bhushan, Haley, and Fong (1978) field study using different methods. The elastic predictions using the Broms (1964) and Poulos (1971) methods with E_s equivalent to the laboratory soil Young's modulus (Table 9) provide generally reasonable and conservative predictions up to about 1/2 in. for drilled shafts of the Bhushan, Haley, and Fong study. The Poulos method is less conservative than the Broms method. The Banerjee and Davies proposal for E_s of 100 to $180c_u$, which is in close agreement with the laboratory soil modulus, therefore appears reasonable for results of the Bhushan, Haley, and Fong field study. Soil moduli taken 7 to 11 times the laboratory soil modulus (Table 9) or more than $1000c_u$ provide unconservative predictions (too little deflection), even at deflections less than 1/2 in. for drilled shafts of the Bhushan, Haley, and Fong study. An E_s of $1000c_u$ might be appropriate as an initial soil modulus as used by Ottaviani and Marchetti (1979) in their finite element analysis of vertical displacements.

92. p - y curves. Solution of the beam column equation using soil reaction-deflection curves and a computer program such as COM622 (Reese 1977) may be the most advanced method available for determining nonlinear load-deflection response, moments, and shears. The slope of the p - y curve is the soil modulus of shaft reaction E_s . The computer program COM622 is oriented toward flexible shafts which assume zero moment and shear at the base. A p - y curve may be provided for each type of soil. This program may cause some error in prediction of lateral load-deflection response for rigid shafts with L/D_s less than

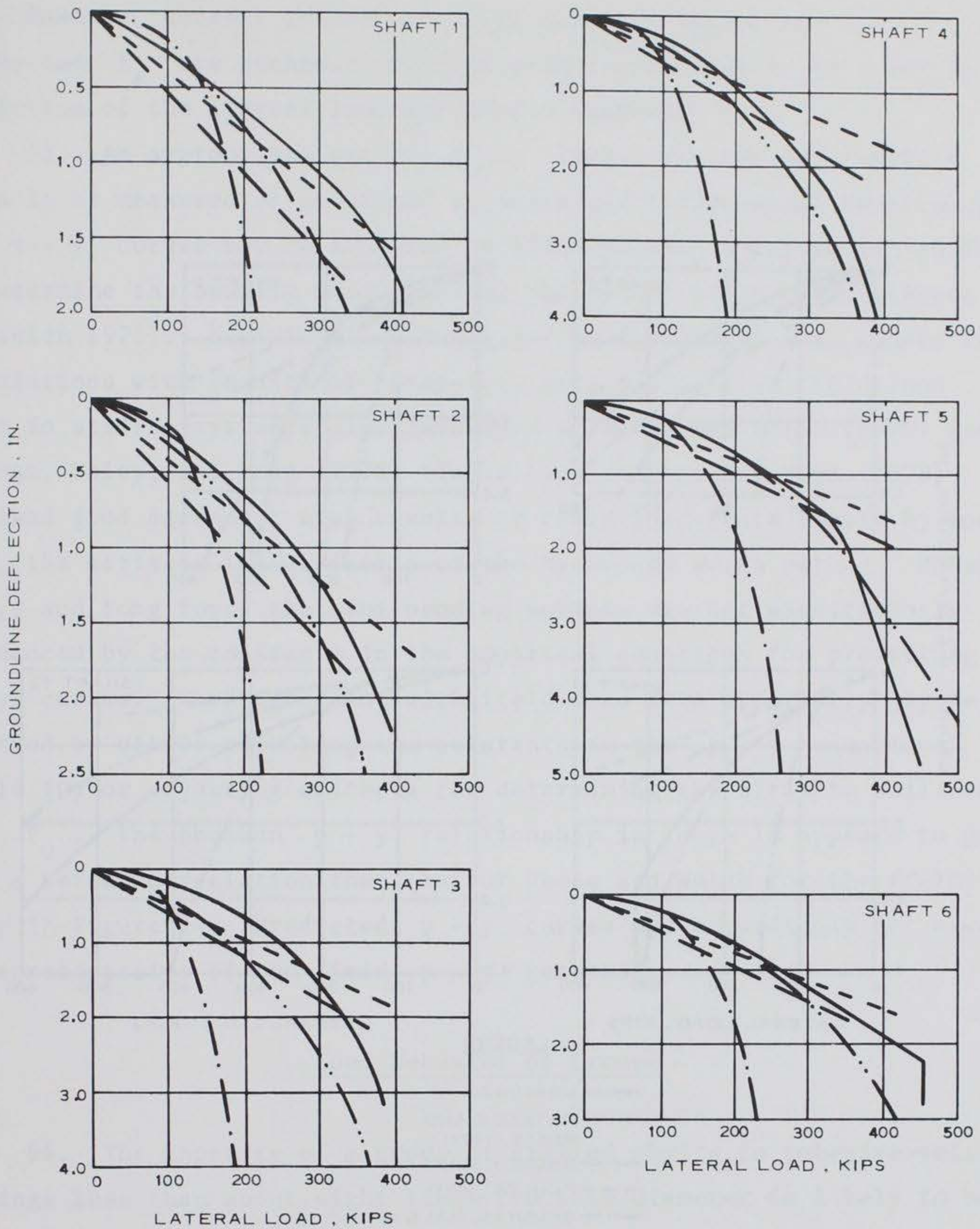

LEGEND

- MEASURED
- MATLOCK AND REESE (1977)
- - - BROMS (1964)
- - - POULOS (1971)
- BHUSHAN, HALEY, AND FONG (1978)

Figure 14. Load-deflection curves from Bhushan, Haley, and Fong's (1978) field study (Continued)

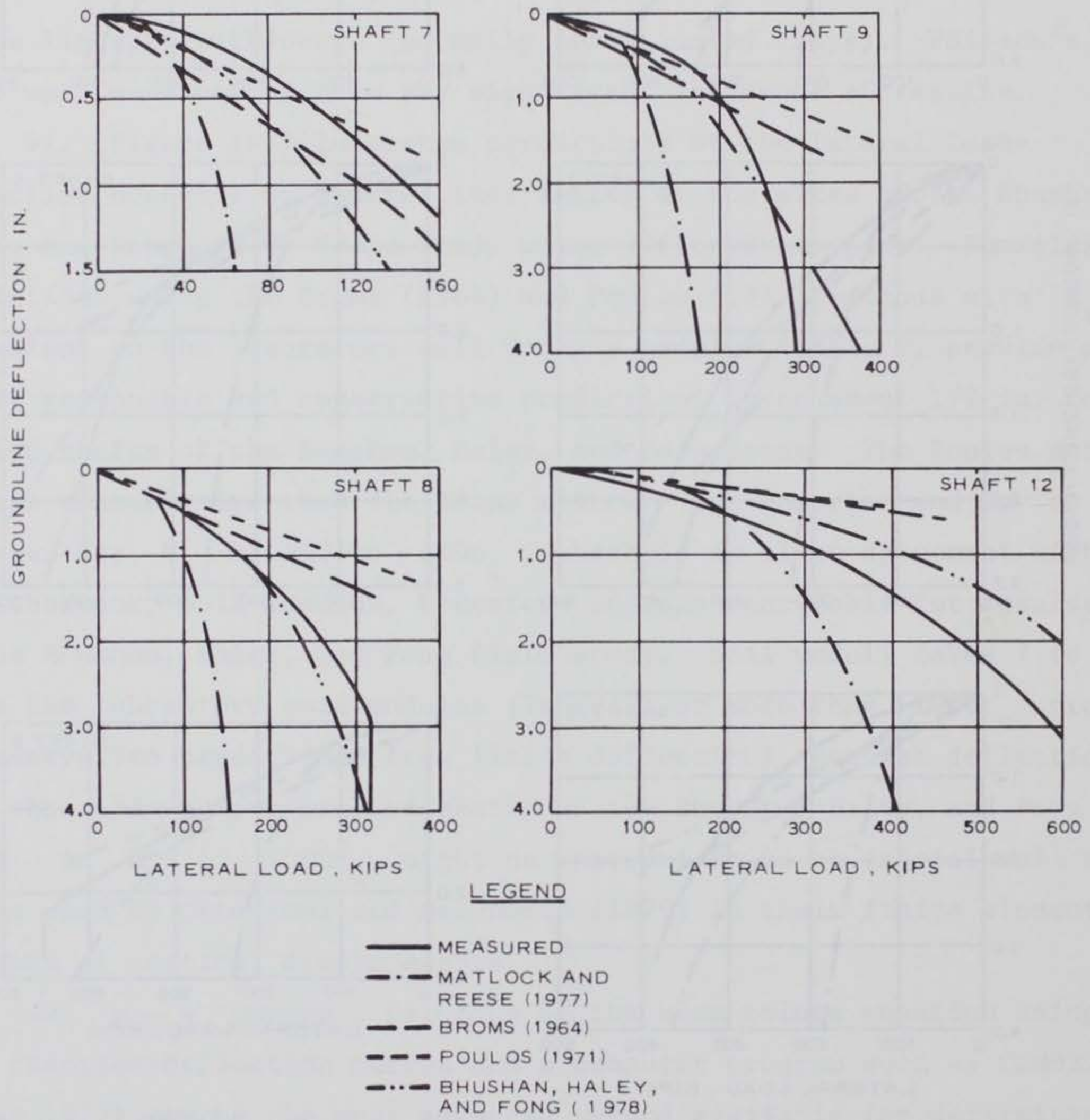

Figure 14. (Concluded)

six. However, current techniques in estimating appropriate $p - y$ curves and E_s are probably the most significant sources of error in prediction of the lateral load-deflection response.

93. An appropriate set of $p - y$ curves for the soil profile needs to be measured or predicted to solve the differential Equation 25. The $p - y$ curves may be measured by field testing instrumented shafts to determine the bending moments along the length of the shaft (Reese and Welch 1975). Empirical equations for predicting $p - y$ curves from correlations with results of laboratory data and lateral field load tests in stiff clays were also developed by Reese and Welch (1975) and Bhushan, Haley, and Fong (1978) (Table 10). Ismael and Klym (1978) obtained good agreement with results of field load tests simply by modifying the ultimate load criteria of the Reese and Welch method. Bhushan, Haley, and Fong found that the bending moments are not significantly influenced by the constants in the empirical equations for predicting $p - y$ curves. Good agreement with field load data apparently may be achieved by either adjusting the constants in the $p - y$ equations (Table 10) or adjusting criteria for determining the ultimate soil reaction P_u . The Bhushan $p - y$ relationship in Table 10 appears to provide a better correlation than that of Reese and Welch for the field study in Figure 14. Predicted $p - y$ curves may accordingly not always be representative of the field $p - y$ response.

Load Behavior of Groups

94. The capacity of a group of drilled shafts in cohesive soil for spacings less than about eight times the base diameter is likely to be less than that of the sum of the same number of isolated shafts (Tomlinson 1975, 1977). The group capacity may decrease and settlements become larger with closer spacings because more subsoil beneath the base is stressed to deeper depths. A group of closely spaced long shafts may, on the other hand, show very little settlement if all the bases can be located in a relatively incompressible stratum. The ability to control the shaft diameter and to support large loads on a single shaft with

tolerable deflections will normally allow construction with large spacings and with no loss in group capacity. The design of drilled shaft foundations may consequently be based on the behavior of single, isolated shafts for most cases.

95. A number of different limit analysis and elastic methods (Table 11) have been suggested for design of shaft groups, but lack of documented field data prevents verification of any optimum method. Methods that use an efficiency formula for ultimate group loads (Tomlinson 1977) or Vesic's (1977) concept for group settlement are adapted to local soil conditions. The Terzaghi and Peck (1967) or Ghanem (1953) method is useful for very close spacings (less than two times the shaft diameter) where block failure is probable. A rigid cap over a group tends to force block failure of the entire group even at fairly large spacings (Murphy 1972). The Poulos method for determining a linear load-deflection behavior uses charts of influence factors for uniform soil and standard designs. The Hrennikoff method is a popular and versatile elastic method applicable to hand calculation of the axial and lateral displacements and rotation of battered shafts.

96. A variety of computer programs (Table 12) has been developed to simplify and increase the accuracy of analysis for axially and laterally loaded groups. These methods consider more complex boundary (e.g., geometry and layout of the group) and more representative soil behavior than hand methods or design charts. The O'Neill and Ghazzaly (1977) method is one of the few that considers interaction effects between shafts in the group; however, computation of the ultimate capacity may not be reasonable. The finite element method (FEM) considers interaction between shafts in a group assuming nonlinear soil behavior and a heterogeneous soil profile, but the geometrical configuration must be kept simple. Analysis using three-dimensional finite elements is presently not practical for routine design because of excessive computer time and lack of adequate confirmation from field load tests. LMVDPILE (Martin, Jones, and Radhakrishnan (1980)) is a practical program oriented toward the routine design of groups of straight or battered shafts. Work at the U. S. Army Engineer Waterways Experiment Station to optimize the placement and number of piles resulted in the computer program PILEOPT (Hill 1981).

Table 11
Load Behavior of Shaft Groups

Method	Equations	Definitions of Terms/Comments
<u>Limit Analysis</u>		
Terzaghi and Peck (1967)	$Q_{ug} = 2L(B + W) \bar{c} + 1.3cN_c BW$	Assumes block failure for spacing < 2 times shaft diameter \bar{c} = average cohesion around perimeter group c = average cohesion beneath group of soil B and W = lateral dimensions of the rectangular group L = length of shafts N_c = bearing capacity factor
Tomlinson (1975, 1977)	$Q_{ug} = E_f n Q_u$	Efficiency formula where $E_f = 0.7$ at $2D_s$ and $E_f = 1$ at $8D_s$, where D_s = diameter of shafts. Settlement computed assuming a raft foundation; sum of elastic and consolidation settlements n = number of shafts
Ghanem (1953)	$Q_{ug} = nQ_u$ $Q_{ug} = 2L(B + W) \bar{c} + 6.5BWc$	Lesser of the two equations shown. Special version of the Terzaghi and Peck equation
Kondner	$Q_{ug} = 2LBc, \text{ for } B = W$ $2Lc[(m - 1)s + 3D_s]$ $Q_{ug} = \frac{2Lc[(m - 1)s + 3D_s]}{\left[1.96\left(\frac{h}{m}\right)^{-R} - 0.05\right] m^{z-2}}$	m = number of shafts along B n = number of shafts along width W s = shaft spacing $R = 0.75 + 0.02166s$ $z = m / [(0.51 - 0.1483s) + (0.516 + 0.046s)m]$
Vesic (1977)	$\rho_g = \sqrt{\frac{B}{D_s}} \rho$	ρ_g = group settlement ρ = settlement of a single shaft with diameter D_s
<u>Elastic</u>		
Poulos (1968)	$\rho_g = \left(\frac{Q_{ug}}{E_s L}\right) R_g I$	Incompressible shaft; no slip between shaft and clay

(Continued)

Table 11 (Concluded)

Method	Equations	Definitions of Terms/Comments
Poulos and Davis (1974)	$Q_{ug} = nQ_u$	R_g = group reduction factor I = influence factor for single shaft E_s = Young's modulus of surrounding soil L = length n = number of shafts
Davis and Poulos (1972)	$\rho_g = R_s \rho$	Results provided for free standing group R_s = settlement ratio ρ = average settlement of a single shaft
Hrennikoff (1950)	Three equations of equilibrium are solved simultaneously to determine lateral and axial displacements and angle of rotation	Linear elastic two-dimensional analysis of battered shafts. Assumptions: load proportional to displacement of shaft head; footing embedded in rigid soil; all shafts deform identically; movements are small

Table 12

Computer Analysis of Shaft Groups

Method	Description	Comments
PASS (Bryant and Matlock 1977)	Rigorous three-dimensional analysis of shaft supported structures. Linear elastic shafts and superstructure; nonlinear axial, lateral, and torsional soil displacement. The superstructure and shafts condensed to the structure-shaft interface. Compatibility at structure-shaft interface	Does not consider effects of interaction of stresses between shafts. Condensation procedure leads to an optimum computational efficiency. Allows nonsymmetrical loading on superstructure
BENT1 (Radhakrishnan and Parker 1975)	Two-dimensional analysis of shaft supported structures. Input data include axial and lateral load-displacement curves for each soil. Iterations to establish equilibrium of forces and compatibility of deflections	Assumptions: lateral forces have little influence on axial response; axial forces significantly influence lateral response; cap rigid. Allows inclined and eccentric loading. Does not consider interaction of stresses between adjacent shafts. Similar to University of Texas program GROUP
O'Neill and Ghazzaly (1977)	Three-dimensional nonrigorous analysis of shaft groups of any geometry, nonlinear response of individual shafts for axial, lateral, and torsional loads, and shaft-soil-shaft interaction. Soil modulus constant or varies linearly with depth	Permits inclusion of coupled shaft behavior between various modes of loading on a single shaft. Motion at the cap is assumed rigid and constrained by the superstructure. Determination of ultimate capacity is relatively inaccurate
FEM (Desai, Johnson, and Hargett 1974)	Three-dimensional system idealized as a structurally equivalent, two-dimensional, plane strain system. Simulates major steps of construction, nonlinear behavior of soils, interaction between shaft and soil	Adaptable to large groups of shafts with fairly uniform properties and symmetry in the third (non-zero strain) direction. Heterogeneous soil profile
LMVDPILE	Analyzes shaft foundation groups using Hrennikoff's method extended to three-dimensional behavior with Saul's method. Soil modulus varies linearly with depth or is constant with depth	Rigid body model supported by set of springs representing forces on structure from shaft. Assumes rigid cap and elastic behavior. Accounts for any degree of fixity of any shaft with cap, different bending stiffness; any elastic torsional, axial, or lateral resistance of any shaft; any position or batter; shafts of different sizes or materials

Evaluation of Design Methods

97. Numerous procedures have been developed to model the mechanisms of the load-deflection behavior of shaft foundations and to provide the necessary design information. No single procedure has been shown to be reliable for all field cases. Each procedure has been limited to local regions or certain soils for which laboratory data and results of field load tests are available. The weakest link in evaluating and optimizing the design procedure is probably determining the most appropriate values for soil shear strength and elastic moduli of the soil.

98. A study, perhaps with the aid of a computer program, is needed to assemble all of the separate loading effects and develop a unified approach for analysis of the forces that can be applied to a drilled shaft. A need also exists for comparisons of the more promising methods of analysis with data from field load tests in an attempt to determine the most suitable design procedure.

Axial loading of single shafts

99. Load capacity. The standard method for evaluating load capacity of drilled shafts is by limit analysis. This is accomplished by summing the contributions of skin and end bearing resistance assuming negligible interaction of stresses (Equation 3). This sum is then divided by a factor of safety of from two to three in order to limit shaft displacements to about 0.5 in. or less. The total stress approach and results of undrained strength tests are normally used to determine the skin and end bearing resistance. The effective stress approach appears promising and possibly more appropriate for analysis of long-term behavior. However, little practical experience is available and lateral and pore pressure data are needed; these data are often difficult to obtain.

100. Limit analysis is not capable of predicting the load-deflection behavior and probable shaft displacement. Prediction of shaft displacement is a useful design tool and can be expected to reduce excessive conservatism often found in the limit analysis approach. Methods

available for predicting load-deflection behavior such as the transfer function and finite element methods show promise as a routine design tool; however, little practical experience is available to confirm the reliability and overall advantage of these methods for routine design.

101. Downdrag. Much of the work on downdrag, which is often caused by soil consolidating adjacent to the shaft, has been done using the effective stress approach rather than total stresses. The skin friction from downdrag may be estimated using Equation 6 and a β factor for clay of about 0.2 to 0.25. Skin friction from downdrag appears to be slightly less than the skin friction developed from normal shaft loads. Downdrag can be considerable for shafts in consolidating fills. The downdrag force is usually negligible for shafts in stiff clay because compression is small and tends to occur slowly.

102. The Terzaghi and Peck (1967) method can be used to provide a conservative estimate of downdrag for shafts in a consolidating fill. Methods for estimating the load-settlement behavior caused by downdrag are generally not available for normally encountered field conditions. Several computer programs have been developed for analysis of the load-settlement behavior assuming simple field conditions with elastic soil behavior.

103. Pullout loads. The resistance of underreamed shafts to pullout loading forces appears analogous to Equation 7 for end bearing resistance, except that F_c is to be determined instead of N_c . The F_c varies between two and four times the L/D_b ratio up to a maximum of nine, the value of N_c for depths greater than five times the shaft diameter. The pullout resistance of straight shafts appears equivalent to the skin resistance f_s (Equation 10).

104. Uplift loads. The uplift thrust appears to be a function of the developed swell pressure in the soil, but is limited by the shaft-soil interface strength. The resistance of shafts to the upward thrust of adjacent swelling soil is much less understood than the mechanism of the pullout resistance. A logical approach to estimating the uplift resistance to the thrust of swelling soil may be to assume that the uplift resistance is analogous to the pullout resistance.

Lateral load behavior of single shafts

105. Practical solutions of lateral load behavior are based on the elastic beam column differential equation by Hetenyi (1946). Reese (1977) and Reese and Allen (1977) have been among those that have offered the best practical solution to this differential equation: the use of lateral load-deflection $p - y$ curves. The greatest current need is to develop improved procedures for estimating these $p - y$ curves for the soil profile. Several empirical equations have been offered, but these estimated $p - y$ curves cannot be expected to represent the actual field response for any field case.

Load behavior of groups

106. The load capacity of a group of drilled shafts in cohesive soil will be the sum of the capacity of individual shafts for widely spaced shafts. Shaft groups with spacings less than eight times the diameter may cause the group capacity to decrease and settlements to increase. Rational analysis of group capacity and load-deflection behavior requires a computer program because of the degree of complexity. The state of the art is in its infancy and is hindered by lack of field data.

PART V: CONSTRUCTION METHODS

107. Construction of a drilled shaft requires boring a hole of specified diameter and depth and backfilling with concrete. Reinforcement is optional depending on the specific project. The diameter, length, and cross-sectional features (i.e., underream or bell) determined during the design process are the results of balancing the structural loads with the load carrying capacity of the foundation soils. The equipment and procedures for construction of drilled shafts are also a function of the foundation soil characteristics and soil profile. Consequently, the design and performance of drilled shafts are significantly influenced by the equipment and construction procedure used to place the foundation. In fact, most of today's problems with drilled shafts are related to construction methods and not to design.

108. A large variety of equipment and three major construction procedures are available for drilled shaft construction. Therefore, to take advantage of best current construction procedures, it is imperative that the construction method be selected as early in the design sequence as possible, preferably when the soil profile is defined and the foundation type (i.e., drilled shaft) is selected. Previous parts of this report have described field exploration, laboratory testing, and design procedures that have been used for drilled shaft foundations. The purpose of this part is to acquaint the engineer with typical equipment, construction procedures, and common problems encountered in the construction of drilled shafts.

Equipment

109. The designer should be familiar with the type and capabilities of equipment available at a particular construction site. Locally available equipment is usually the most economical. The designer should also assume that the contractor will use the lightest equipment possible and will tend to complete the foundation portion of the work as rapidly as possible. The contractor must have the proper equipment with

sufficient capacity to complete the drilling requirements. The design should avoid multiple shaft or underream sizes as increased time and delay for changing drilling tools results in significantly higher costs (Woodward, Gardner, and Greer 1972). The unit cost (per cubic yard) tends to decrease as the diameter of the shaft increases.

Drilling equipment

110. Commercially produced drilling equipment suitable for drilled shaft construction may be classified according to the mounting and relative capacity as indicated in Table 13. Some advantages and disadvantages of different types of rig mountings are shown in Table 14. Drilled shafts up to 17 ft in diameter and more than 120 ft deep are possible with present equipment.

111. Figure 15 illustrates how the cost is expected to compare with the different size rigs given in Table 13. The capacity of the drilling rig should therefore be closely matched with the work requirements to optimize economy. The drilling machine should operate within its continuous working range and not toward the limits of its upper capacity.

Auxiliary equipment

112. The common types of auxiliary tools used with drilling rigs are described in Table 15. These tools include augers, underreamers, clean-out buckets, vibratory hammers, and rotary equipment. Drilling with augers is usually much more economical than use of core barrels or other rotary tools with the lighter rigs (Woodward, Gardner, and Greer 1972). Auger drilling requires more torque than core barrels, roller bits, or down-hole chopper bits, but the hole may be made much faster.

113. Underreams are used to increase anchorage and end bearing resistance. Bell diameters as much as 3 times the shaft diameter are possible but are usually limited to 2.5 or less in practice. Underreamers are inefficient for removal of material, and the underream cannot be cased to prevent caving. A theoretical analysis (Reese and Allen 1977) shows that the 45-degree bell may cause larger stress concentrations than the 60-degree bell in drilled shafts, but the 45-degree bell requires less concrete and less cutting time. There is no practical

Table 13

Equipment for Drilled Shaft Construction*

Type	Example	Nominal Shaft Diameter, in.	Nominal Depth, ft	Torque ft-lb	Remarks
Light duty, 12-ton truck-mounted	Texhoma 270	<24	20	10-20	Post hole truck-mounted rigs; underreams to 72 in.; maximum batter 15 degrees from vertical on intermittent basis; cost \$600-800 per day
Medium duty, 20-ton truck/ crawler-mounted	Watson 1000 Texhoma 600	<48	40	<60	Maximum batter 15 degrees from vertical; cost \$600-800 per day
Heavy duty, 35-ton carrier/ crawler-mounted	Hughes LDH Hughes LLDH Watson 3000 Reed Taurus	48-72	100	50-100	Capable of large 40- to 60-kip down forces on the kelly; augers rocks of unconfined strength 4 to 8 psi; maximum batter 60 degrees from vertical; cost \$1000-1200 per day
Crane-mounted, >35 tons	Hughes Watson Stewart- Stevenson	up to 200	≥120	100-150 (typical)	Applied to extra large shafts and special shaft requirements; i.e., low overhead using rodless drill, deep shafts and very large belled footings; cost \$1200-1500 per day. Mobilization costs \$1500, or more for long hauls

* From Watson (1978) and Farr (1978).

Table 14

Advantages and Disadvantages of Drilling Equipment*

<u>Type of Mounting</u>	<u>Advantages</u>	<u>Disadvantages</u>
Truck	High mobility, capable of moving at highway speeds, easy maneuverability from hole to hole provided ground is sufficiently firm for tires; minor mobilization costs	Limited auger and underream height; limited torque
Crawler	Site mobility excellent; handles taller augers and underreamers than truck mounted rigs	Less adaptable to small jobs than truck mounted rigs; requires heavy equipment trailers; less mobile than truck mounted on highways
Crane	Handles taller augers and underreamers than truck mounted rigs; large lifting capacity; readily mobile on soft ground if mounted on tracks	Same as for crawler. Mobilization costs high

* From Woodward, Gardner, and Greer (1972).

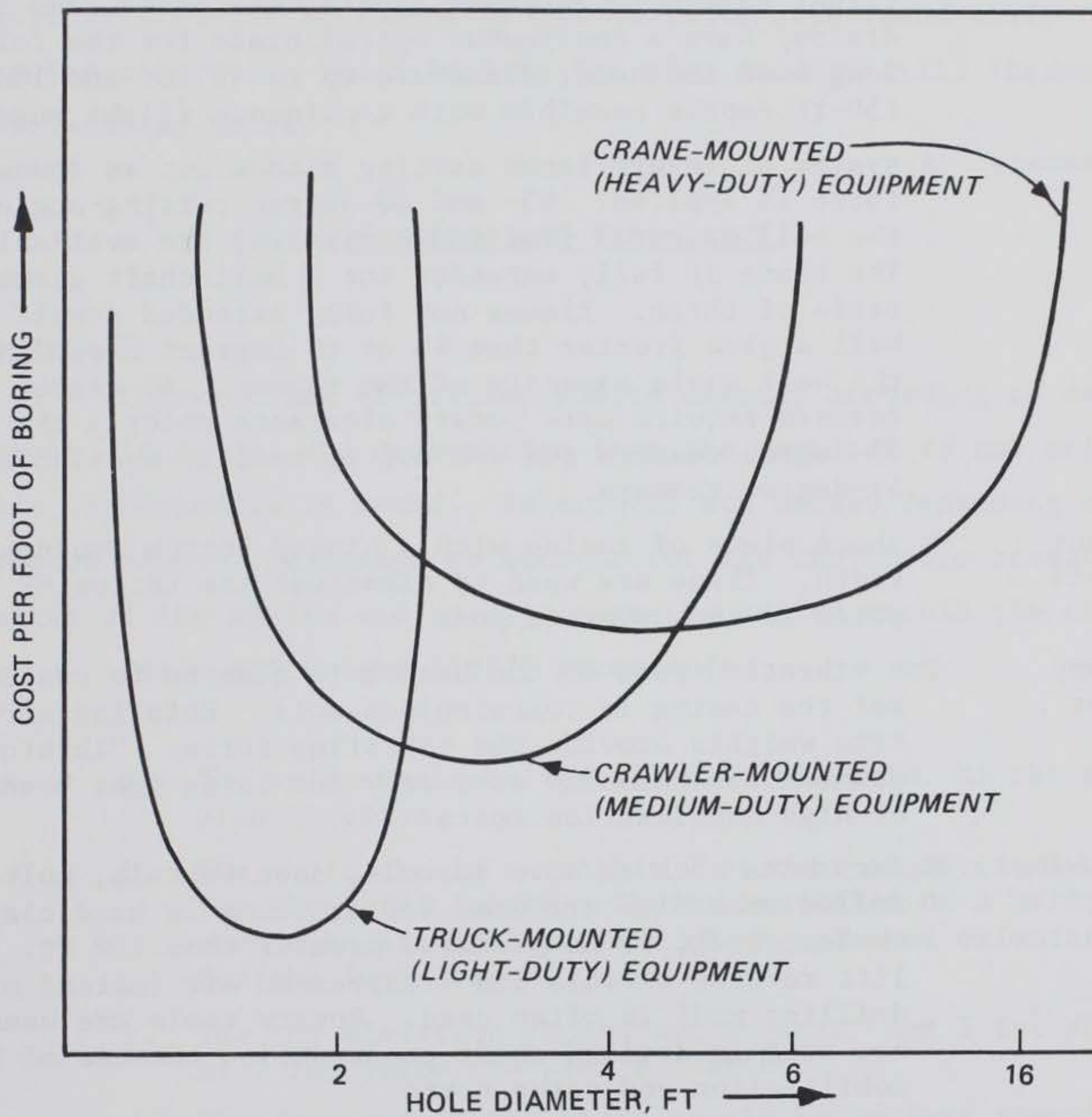

Figure 15. Relative costs for different drilling equipment (After *Drilled Pier Foundation*, by Woodward, Gardner, and Greer. Copyright © 1972 by McGraw Hill, Inc. Used with the permission of McGraw-Hill Book Company)

Table 15
Auxiliary Equipment*

Tool	Description
Augers	Open flight, continuous spiral blade, 4 to 6 ft long; some equipped with a cutting edge or cutting teeth. Tungsten carbide teeth used in rock formations. Continuous flight augers (auger-cast shafts, tie backs, and sand drains) have a continuous spiral blade for the full length of the hole; diameters up to 48 in. and 100- to 150-ft depths possible with continuous flight augers
Underreamers	A system of levers force cutting blades out as downward force is applied. 45- and 60-degree cutting angles of the bell measured from the horizontal are available. The blade is fully extended for a bell-shaft diameter ratio of three. Blades not fully extended result in bell angles greater than 45 or 60 degrees depending on the bell angle capacity of the reamer. 60-degree reamers require more rotary clearance under a rig than 45-degree reamers and are not as readily available as 45-degree reamers
Clean-out buckets	A short piece of casing with a hinged bottom equipped with teeth. These are used to clean out the bottom of holes prior to the concrete pour
Vibratory hammer	The vibrating part of the hammer is clamped to casing to set the casing in cohesionless soil. Rotating eccentric weights provide the vibrating force. Vibratory hammers are normally used only for large jobs because of high mobilization costs
Rotary bits	Rotary bits such as core barrels, shot barrels, multi-roller rock bits are used for drilling in hard clay shales, rock, or deep shafts greater than 150 ft. Air lift reverse circulation (compressed air instead of drilling mud) is often used. Rotary tools are usually not used in drilled shaft construction because of high mobilization and setup costs

* After Farr (1978), Woodward, Gardner, and Greer (1972).

field information to indicate that the 45-degree bell is less satisfactory than the 60-degree bell. Sixty-degree bells also require a crane for bells larger than 66 in. in diameter (Farr 1978). The minimum diameter shaft recommended for underreams is 1.5 ft (Reese and Wright 1977).

114. Clean-out buckets are efficient for removal of loose sediment and cuttings from the bottom of slurry-filled shafts immediately before placing the concrete. These buckets are also used to drill through sand in slurry-filled holes.

Construction Procedures

Tolerances

115. Construction of drilled shafts exactly according to designated dimensions, location, and orientation from the vertical is not practically possible or economically sound. Tolerances are needed depending on costs required to adjust the design to account for the inevitable eccentricity and batter of the shafts and to construct the shafts within the chosen tolerance. Reese and Wright (1977) recommend:

- a. The axis should be installed within 3 in. of the shaft's plan location.
- b. The shaft should be within 2 percent of vertical plumb for the total length. Shafts installed on a batter should be within 5 percent of the planned orientation for the full length.
- c. The top elevation should not be more than 1 in. above or 3 in. below the plan elevation.
- d. The diameter of the shaft should be no less than 1 in. smaller than the plan dimension. The bearing area of the underream should be as large as that of the planned underream.

The contractor should be given as much freedom as possible to construct the drilled shaft foundation according to the methods that he has found best, provided that construction is of the required quality within specified limits. The use of innovative techniques should not be restricted.

Methods

116. The three methods recognized for construction of drilled shafts depend on the subsurface soil conditions (Figure 16): dry, casing, and slurry methods. The dry method is applicable to soils that will not cave, slump, or squeeze (reduce the diameter) when the hole is bored to its full length. Seepage should be insignificant while the boring is open. Soils suitable for unsupported holes include low-permeability stiff clays and sometimes moist sand above the water table. The casing method is applicable to soils where caving or excessive deformation will occur within the hole during excavation. The casing is pushed into an impermeable, firm stratum below the caving soil. The slurry displacement method is applicable to any soil conditions where the casing cannot be sealed to prevent seepage or caving into the hole. Much of the following summary of construction methods was taken from Reese and Wright (1977) and Farr (1978).

117. Dry method. The excavation is normally carried to its full depth using an auger tool. An underreaming tool may then be used to enlarge the base of the drilled shaft if bells are required. The cuttings collect in the reamer and are unloaded on the surface. The bottom may be cleaned by turning the reamer about one fourth turn with the blades open, then closing the blades and repeating the procedure for the entire perimeter of the bell. A bell constructed by a skilled operator using a reamer of good design will leave minimal cuttings at the bottom. A good reamer has sufficient space between the bottom of the blades and hinged bottom to catch the cuttings. A clean-out bucket may also be used to remove loose cuttings at the bottom of the excavation (Farr 1978).

118. Following clean-out and inspection of the hole, concrete may be placed into the shaft by free-fall, or preferably through a tremie to minimize segregation in the concrete and to prevent concrete from contacting the sides of the shaft. The concrete is placed to the elevation of the bottom of the rebar cage if reinforcement is used, the cage lowered to the level of the concrete (without hitting the sides of the shaft with the cage), and the remaining concrete placed into the hole

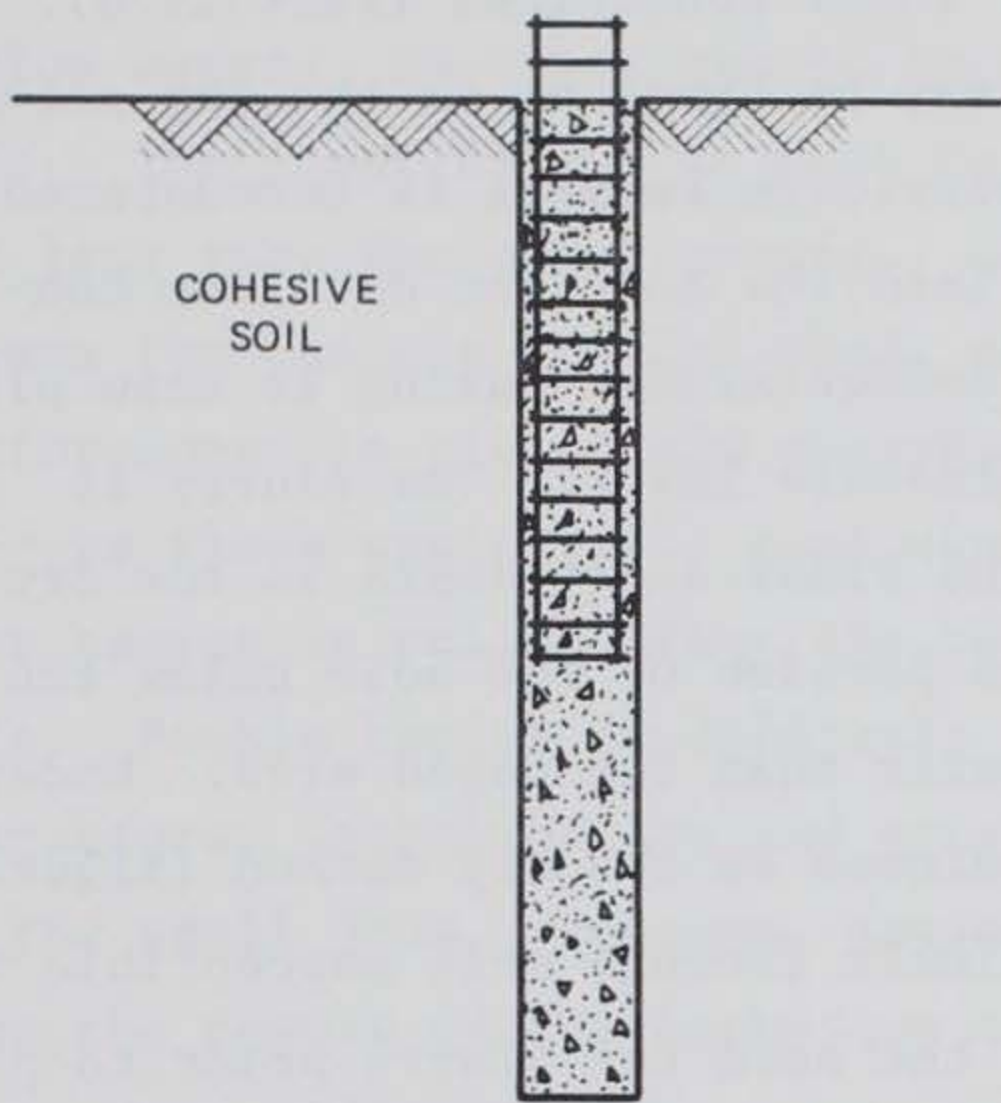

a. SHAFT CONSTRUCTED USING THE DRY METHOD

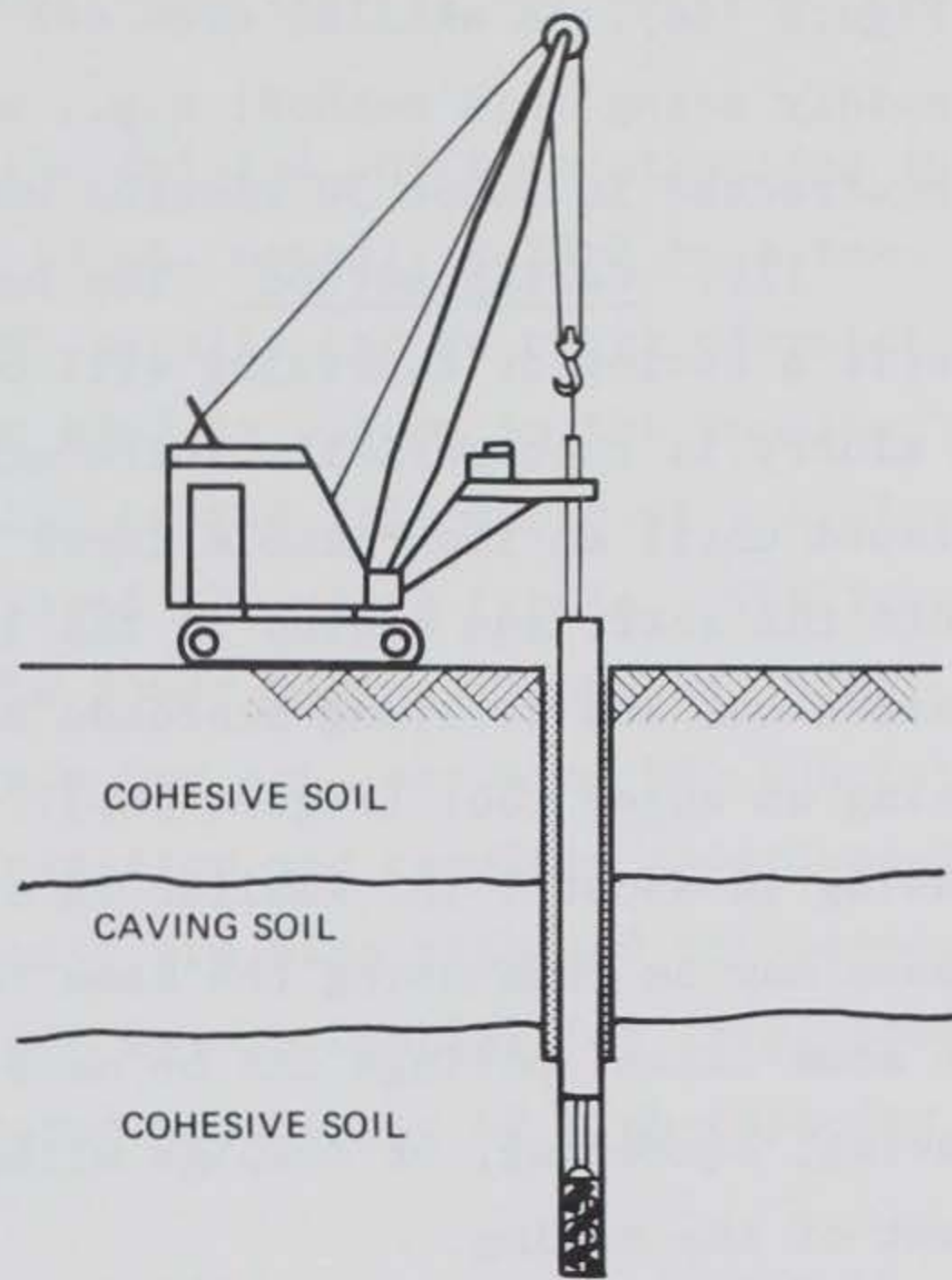

b. DRILLING WITH THE CASING METHOD

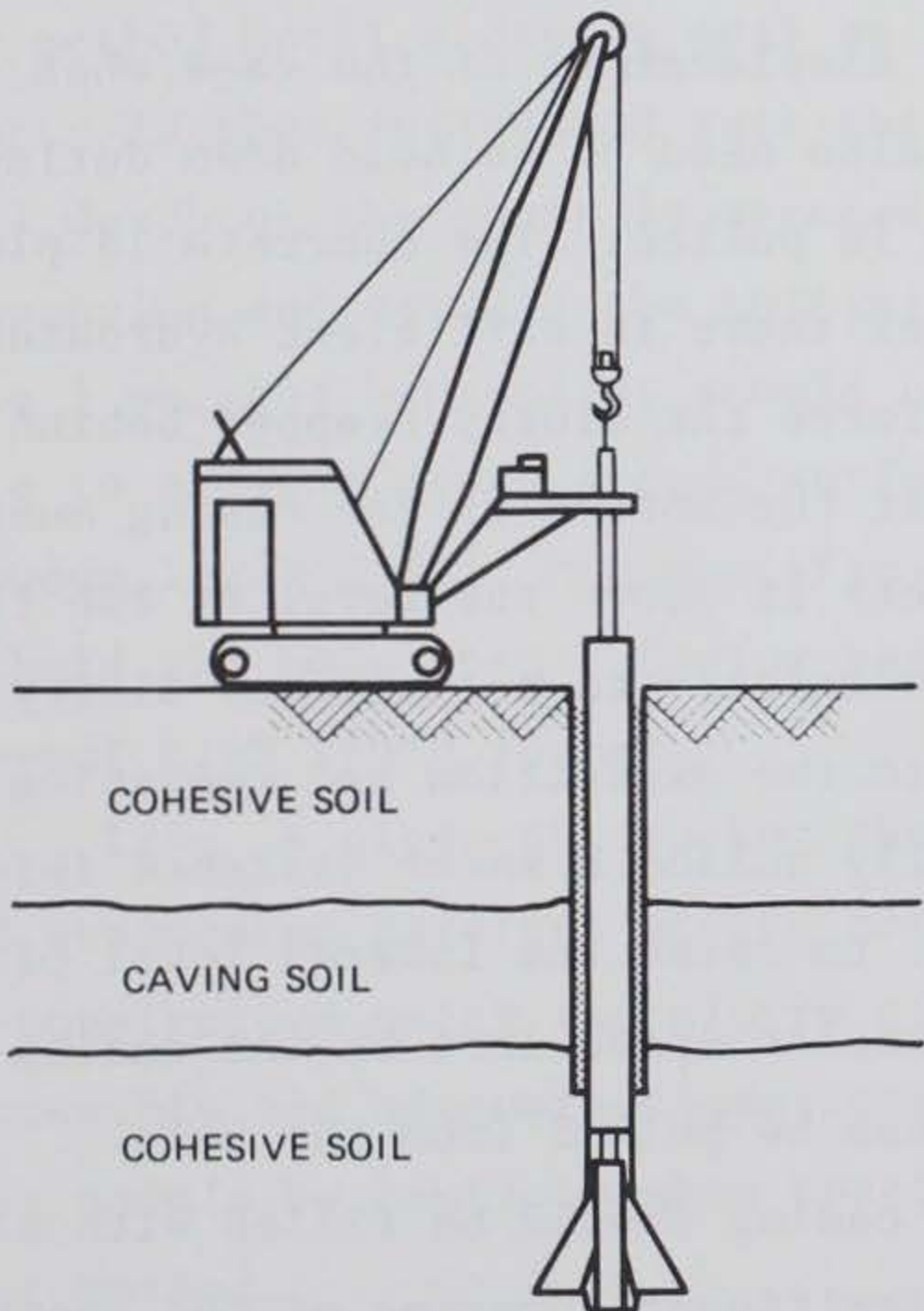

c. UNDERREAMING WITH THE CASING METHOD

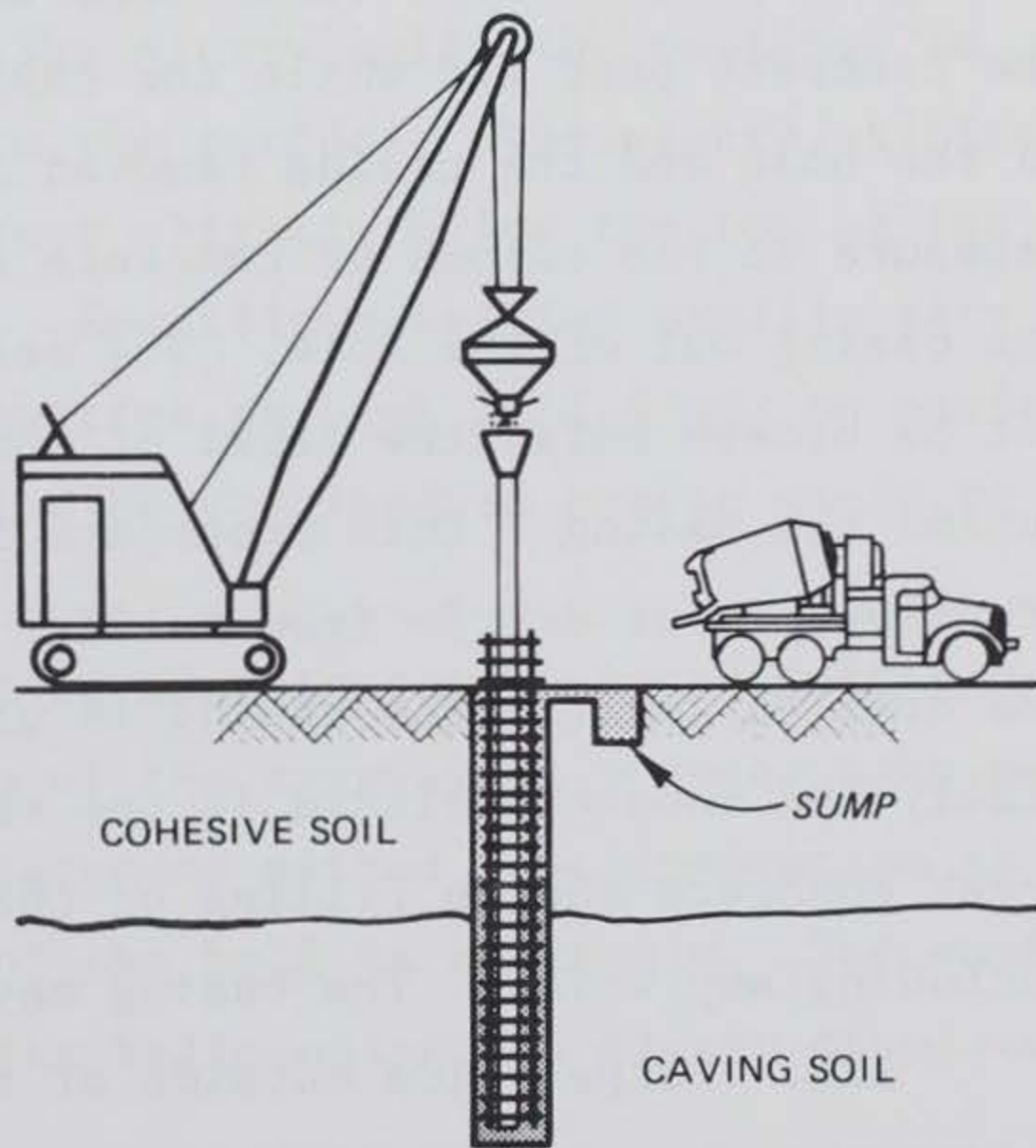

d. PLACING CONCRETE USING A TREMIE AND THE SLURRY METHOD

Figure 16. Examples of drilled shaft construction methods (after Reese and Wright 1977)

(Figure 16a). A skilled crew can drill and place concrete in shafts very rapidly using this method; e.g., a 36-in.-diam by 50-ft shaft may be constructed in about 30 minutes under ideal conditions (Farr 1978).

119. Casing method. The hole may be bored as in the dry method until a caving or squeezing soil or excessive seepage is encountered. A slurry is then normally introduced into the hole and drilling continued until an impermeable layer is encountered. Casing is then placed into the shaft and sealed in the impermeable layer. The slurry is bailed out and drilling proceeds to the final shaft depth in the dry using an auger tool (Figure 16b). The portion of the hole below the casing is about 2 in. smaller in diameter than the cased area. Underreams may be made using the same techniques as the dry method (Figure 16c). In some cases, borings can be made quickly through soil susceptible to caving, squeezing, or seepage without the need for slurry prior to placement of the casing.

120. The rebar cage, if required, should extend to the bottom of the drilled shaft to minimize downward displacement of the cage when the casing is pulled. The rebar cage may also need to be held down during the concrete pour and while the casing is pulled. The concrete is placed in the hole and the casing removed after there is sufficient hydrostatic pressure in the column of concrete to force the slurry trapped behind the casing out of the hole. The seal at the bottom of the casing must not be broken until the level of concrete is above the level of the fluid behind the casing. This procedure is necessary to prevent any slurry, groundwater, or debris from falling into the excavation and weakening the drilled shaft. The casing is usually pulled a short distance initially and concrete placed in the shaft to raise the lowered level of fresh concrete due to filling of the annular space left by the casing including any voids. The casing may then be pulled from the hole.

121. Large voids outside of the casing should be filled with sand before the casing is pulled to avoid significant lowering of the concrete level and large downdrag forces on the reinforcement due to filling of the voids. Pea gravel should not be placed between the casing and walls of the hole because the friction may cause the casing to stick. Casing

should not be left in the hole overnight, otherwise it may not pull out the next day.

122. Double casing is required for drilled shaft construction in shallow water. An outer casing is set first, usually guided by a template. The inner casing is then set and usually has an outer diameter 1 ft less than the outer casing. Clean sand is placed in the annulus between the casings and the shaft drilled to the full depth with a slurry. Reinforcement is placed and concrete placed through a tremie. The fresh concrete flows against the sand when the inner casing is pulled. The outer casing is pulled after the concrete has set, exposing the concrete shaft. Double casing is difficult in practice and requires experienced contractors. Mobilization and setup costs are also high and not economical for small jobs. However, savings can be substantial for large jobs using the double casing technique compared to the use of high-capacity piles (Farr 1978).

123. Slurry displacement method. Drilling proceeds as with the dry method until a caving soil or excessive seepage is encountered. Slurry is then introduced into the hole and drilling continues until the full depth of the shaft is reached. The slurry holds the cuttings in suspension and carries the cuttings to the surface. The slurry, typically 3 to 5 percent bentonite, should be kept slightly below the top of the hole to avoid a messy ground surface. Specific gravities usually vary between 1.2 and 1.5, but specific gravities as high as 1.8 may be needed to hold the hole open. Casing may also be required in coarse sands to prevent high fluid losses.

124. A clean-out bucket should be used to remove loose cuttings and sedimented material at the bottom of the excavation. Underreams may be constructed using the slurry displacement method, but inspection is impossible and adequate cleanliness of the bell is uncertain. The engineer should be cautious when specifying bells using the slurry displacement method.

125. Partial- or full-length rebar cages may be inserted into the hole as required and concrete placed through a tremie. The rebar cage may need to be held down while the concrete is being placed. The end of

the tremie is closed (e.g., valve, plywood plate over the end, polyethylene, and tire rubber band) until the tremie is at the bottom of the hole. The tremie is slowly raised while placing the concrete, but the tip is always kept preferably 5 to 10 ft within the column of fresh concrete. Production rates using the casing or slurry displacement methods are much slower than those using the dry method and may easily be limited to 3 or 4 shafts a day. The use of slurry is time-consuming, and it often must be hauled off after the work is finished.

Steel reinforcement

126. The rebar cage must be designed to meet the structural requirements for bending, imposed compression or uplift loads from the superstructure, any downdrag forces expected from consolidation of the foundation soil or fill, or any tension forces from heaving soil. The rebar cage must be stable during placement in the hole and placement of concrete and during withdrawal of the casing. Horizontal bands may be placed around the caging to prevent lateral spreading, and joints should be tied to prevent slippage. The spacing of the rebars and circumferential bands should be large enough to ensure adequate flow of concrete through the openings; i.e., openings should be three times the maximum size of the concrete aggregate.

Concrete placement

127. The strength of the concrete mix should be 3000 psi or greater and the slump should be at least 4 in. and preferably 6 to 7 in. for adequate flow properties. Air-entraining agents or chemicals may be added to increase workability. The water-cement ratio must not be too high to avoid excessive bleeding or laitance. The maximum size aggregate should be limited to about one third of the rebar spacing or about 3/4 in. The concrete should be inspected closely before placing into the hole to avoid hot or flash setting of the concrete. Chemicals to retard the concrete set should be used in cased and slurry borings to avoid any set while placing. The concrete should be placed into the hole as soon as possible after boring and at least on the same day to minimize construction problems.

128. Concrete overruns are normal, but could indicate a problem

and should be less than 3 or 4 yd³ per shaft. Concrete underruns may also indicate a problem, such as water contamination or collapsed soil filling part of the hole causing a defective shaft, and should be investigated. A record of the concrete placement should be kept for each shaft.

Construction Problems and Inspection

129. Long experience has shown that cast-in-place concrete drilled shafts are a reliable and economical form of foundation. Nevertheless, there are many problems associated with the construction of drilled shafts. These problems often cause unnecessary misunderstanding between the owner of the structure, the design engineer, and the contractor and may involve significant claims, construction delays, and remedial work.

130. Many problems occur from an inadequate understanding of the actual soil profile and groundwater conditions. Problems also occur from mistakes made while drilling. Other problems are associated with inadequate flow properties of the concrete and improper steel reinforcing. The following summary taken from Farr (1978), Reese and Wright (1977), and Thorburn and Thorburn (1977) describes significant problems encountered with construction of drilled shafts.

Inadequate information for design

131. Soil and groundwater conditions. A common and difficult problem that often causes the most trouble during construction is that of obtaining adequate, reliable, and useful information on soil and groundwater conditions. This information is needed by the contractor as well as the designer to aid in estimation of the work and selection of the proper equipment to complete the job economically. Complete boring logs showing all strata, location of changes in the strata, whether water was or was not encountered, and locations of water are especially important.

132. The designer should be familiar with local experience and actual site and soil conditions so that the proper options for drilling will be specified and available to the contractor to optimize efficiency. Refer to ER 415-1-302, "Inspection and Work Records," ER 1110-2-1200, "Plans and Specifications," and ER 1180-1-6, "Construction-Quality Control" for examples of specifications.

contractor needs to know (a) site conditions so that equipment of the proper surface mobility can be selected and (b) subsurface soil conditions so that equipment of adequate capacity can be made available for drilling dry, with casing, or in slurry as needed.

133. Mixing equipment not suited to each other should be avoided. For example, a continuous flight auger often leads to loose cuttings at the bottom of the hole. A clean-out bucket is necessary to remove the cuttings, but such a bucket is difficult to use with a continuous flight auger and the necessary clean-out may not be done (Farr 1978).

134. Examples of inadequate specifications from lack of soil data. Farr (1978) described the calling for bids based only on casing without slurry. During construction, the contractor could not find an impermeable layer to seal the casing, and the caving layer was found too thick to drill through without slurry. The job was shut down for a long time and many claims were filed.

135. Another example (Farr 1978) illustrates the difficulty of reaming bells when a single thin layer of permeable soil is in the belled area. The permeable zone was missed during soil sampling and slurry was not specified. The bell could not be reamed without slurry and the shaft was eventually required to go 90 ft or three times the original specified length before a suitable layer was found. The slurry displacement method would have been much more economical if it had been permitted by the contract.

136. When casing is required for a job, the specifications should call for size of the upper portion of the hole in even, 6-in. increments; i.e., 18, 24, 30 in. The use of casing means that the lower part of the hole will be about 2 in. less in diameter. Casing is much easier to find in 6-in. increments than in 2-in. increments, while odd-sized augers are much more easily found.

137. Overbreak. One of the worst and most common problems with drilled shaft construction is overbreak, which is defined as the loss of material outside of the nominal diameter of the shaft due to caving soil. Overbreak can cause local cavities or defects in the shaft. The construction procedure must be chosen to minimize overbreak and to eliminate

defects in the concrete of the shaft as a result of overbreak.

Problems with the dry method

138. Most problems using the dry method occur from caving or squeezing soil and seepage. It is often difficult to predict the potential for caving or seepage without local experience. Stiff or very stiff cohesive soils with no joints or slickensides are usually needed for this method. Some shafts have been successfully constructed in sands above the water table. Squeezing in soft clay will probably be a problem if the ratio of effective overburden pressure to undrained shear strength is greater than six.

139. Underreams, especially large underreams, are vulnerable to caving and should be constructed as quickly as possible. The diameter of the bell-shaft ratio should therefore be specified less than three and preferably about two. Underreaming tools also have a tendency to ream up or down. Excessive up reaming may cause loose material in the hole, while excessive down reaming may make the bell unstable or more susceptible to caving.

Problems with the casing method

140. Drilling without slurry. An important problem with the casing method is trying to drill through caving soil without slurry. Slurry should be used while drilling through caving soil prior to placement of casing and sealing in an impervious layer, unless local experience has shown that slurry is not necessary. Slurry drilling significantly increases the cost of drilling and should be a part of the cost estimate when using the casing method. Since casing normally cannot be continuously installed while drilling, the hole should be drilled within a foot or two of the planned bottom elevation of the casing before the casing is set.

141. Underreams. Casing is usually set 6 in. to 1 ft into the impermeable stratum. The base of the bell must be deep enough below the casing so that the blades on the reamer will open the required amount. A 45-degree reamer requires a length below the casing about twice the shaft diameter.

142. Concrete placement. The casing should not be pulled until

the head of concrete is sufficient to balance the water head external to the casing. Groundwater will otherwise mix with the concrete and cause defects or voids in the shaft. If the casing is pulled too rapidly and in a jerky, discontinuous motion, the concrete tends to flow beneath the bottom of the casing in a rippled pattern such that slurry may be trapped rather than displaced. Concrete that is too stiff will aggravate this problem. The water-cement ratio of the concrete should also be low enough to minimize washing out of cement from the aggregate and to minimize accumulation of free (laitance) water at the top of the shaft.

143. Localized reduction in the shaft diameter (squeezing or waisting) can occur in soft soils when the casing is pulled. The uplift forces, strains in the fresh concrete, and high lateral soil pressure lead to squeezing of the soil. Squeezing is minimized by using high-slump concrete with a sufficient pressure head on the concrete.

144. Extraction of the casing will cause a large drop in the level of the fresh concrete if large voids exist outside of the casing. Debris may fall on top of the lowered concrete surface while the casing is pulled. Concrete may sometimes be added by tremie after the casing is pulled partly out of the hole before the placed concrete begins to set. To avoid a defective shaft, additional concrete should not be placed after the casing is pulled or if there is a possibility of debris collecting in the shaft. All large voids should be filled with sand or other appropriate material prior to removal of the casing.

145. Casing may tend to stick in place during concrete placement. Attempts to knock the casing loose take time and may allow the concrete to set. The concrete may separate along the shaft when the casing is pulled and cause voids in the shaft. The casing should be left in place if the concrete appears to be setting up.

146. Steel reinforcement. Partial-length steel causes support problems when the casing is pulled. The downward movement of the concrete causes enormous dragdown forces on the steel that probably cannot be countered with surface equipment and without damage to the reinforcement. Steel reinforcement should be full length to avoid this problem. Partial-length steel is no problem with slurry displacement without

casing and can be easily supported while pouring the concrete.

147. Inadequate openings in the rebar cage will not allow the concrete to flow through the cage. Openings should be three times the maximum size of the concrete aggregate. Horizontal bands can be welded to the lower portion of the rebar cage in place of spirals to minimize lateral movement of the cage while the casing is pulled.

148. The rebar cage may also lock to the casing while the casing is pulled. This problem is aggravated by large concrete aggregate and a small clearance between the casing and the reinforcement. The casing should clear the cage by at least 3 in.

Problems with the slurry method

149. One of the worst problems is caving of unstable soils. Gravel or coarse sands are most susceptible to caving in a slurry-filled hole. Caving should be avoided with higher density slurries. Slickensided clays can also cave in in a slurry-filled straight shaft. Slurries that are too viscous may not be completely displaced by the concrete and not thoroughly scoured from the perimeter of the shaft or from the steel of the rebar cage.

150. The density of the slurry may be increased by adding inert solids such as barite, while viscosity may be increased by adding bentonite (Leyendecker 1978). Bentonites are not used in salt water as these will flocculate and will not hydrate such that the viscosity stays low. Fibrous (Attapulgate) clays or salt gels are used in salt water. These develop mechanical viscosity from hard agitation. Drilling fluids are kept clean to avoid excessive density and viscosity by use of shake screens and other surface process systems. Fresh fluids should be used for new borings. Figure 17 illustrates the viscosity resulting from different clay solids (Leyendecker 1978). The yield in Figure 17 is defined as the number of barrels of 15 centipoise (cps) mud that can be obtained from 1 ton of dry material. Figure 17 shows that small amounts of clay above 15 cps have a significant effect on viscosity. Table 16 provides a rough guide for appropriate viscosities measured by the Marsh cone funnel (Farr 1978). The units in Table 16 represent the time in seconds required to pass 1 quart of fluid through the funnel.

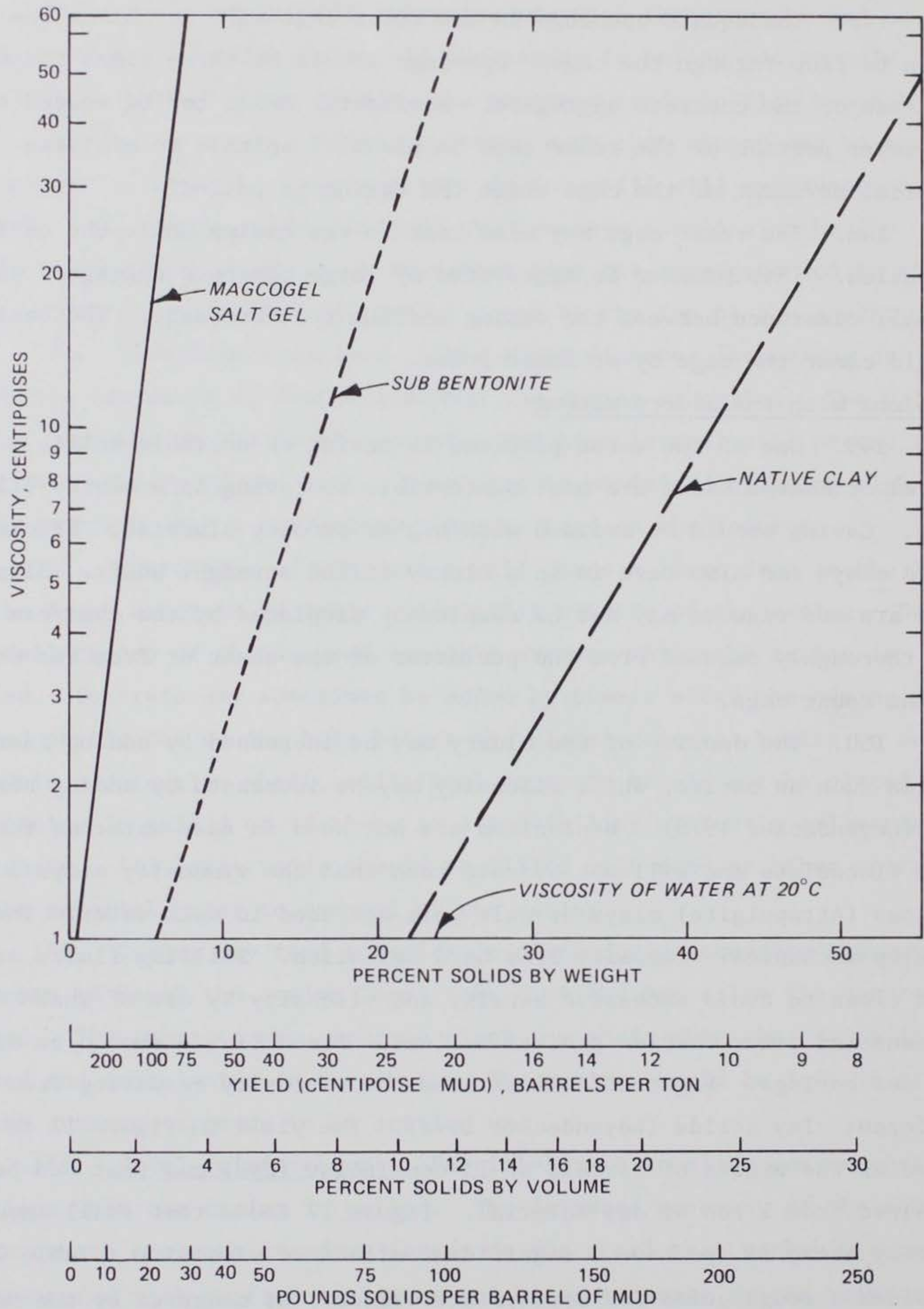

Figure 17. Viscosity curves resulting from different clay solids (adapted from Leyendecker 1978)

Table 16

Appropriate Viscosity of Stabilizing Solution*

Type of Ground Formation	Funnel Viscosity, seconds	
	Without Groundwater	With Groundwater
Clay	--	--
Sandy silt, sandy clay	29-35	32-37
Silty sand	32-37	38-43
Sand, fine to coarse	38-43	41-47
Sand and gravel	45-52	60-70

* From Farr (1978).

151. Loose cuttings. Slurries that are too thin may allow the cuttings to settle to the bottom where they may cause excessive settlement after loads are placed on the shaft. Loose cuttings adhering to the perimeter of the hole can cause inclusions and voids in the shaft.

152. Concrete placement. The tremie sometimes becomes plugged stopping the flow of concrete. If the tremie is withdrawn, some concrete may fall into the slurry. The slurry may quickly become very viscous from flocculation and difficult to pump. Inclusions may occur in the shaft following reinsertion of the tremie into the concrete and continuation of the pour. Construction of new shafts on either side of the existing shaft may be necessary. As a rule, the tremie should not be pulled above the concrete level in the shaft before the pour is completed.

153. Steel reinforcement. The reinforcing cage may tend to move up if the tremie is too deep in the concrete and if the concrete is poured too rapidly. The cage very likely cannot be pushed back down. The reinforcing steel can be restrained from movement by holding the cage at the top or by a doughnut-shaped steel form clamped to the tremie during the pour.

Problems with groundwater

154. Drilled shafts may become defective from moving groundwater or from chemical attack. Moving groundwater leaches out the cement in fresh concrete and washes the aggregate. These defects are usually

associated with permeable soil such as sands and gravels with large hydraulic gradients. Drilled shafts may also disintegrate from the presence of deleterious compounds in solution in groundwater or from seawater. Severe disintegration of concrete in drilled shafts had been experienced from sulfate attack (Thorburn and Thorburn 1977).

Inspection

155. The performance of drilled shaft foundations is determined by the quality of the construction as well as the design. Adequate inspection is necessary to (a) ensure adequate site investigation and supervision and (b) minimize bad construction practice and poor workmanship. The geotechnical engineer or consultant is often asked to inspect the construction operation for the owner.

156. Items that the inspector should observe are described in Table 17. These items include a check of the shaft and bell dimensions; evidence of caving, squeezing, or seepage; condition of casing; loose cuttings at the bottom of the hole; adequate concrete slump; tremie kept below the concrete level during the pour in slurry-filled holes; adequate concrete head in the shaft prior to pulling of the casing; and reinforcement of specified design and strength.

157. Open holes should not be entered until adequate safety is established. The minimum diameter is 1.5 ft. Caving soil should be contained by a protective casing and fall-in from the top should be eliminated. Air within the hole should be in good, breathable condition or an air mask provided. Safety harnesses and lines should always be used. Refer to the Corps of Engineers Safety Manual, Engineer Manual 385-1-1 (Headquarters, Department of the Army 1977), for further details.

Table 17
Inspection Check Points

Operation	Check
Drilling	Proper shaft dimensions Collapse of hole Weak soil or cavity beneath base of footing
Dry method	Loose cuttings in the hole Minimal seepage at the bottom; less than 2 to 3 in. if end bearing Concrete does not strike the shaft perimeter free-fall
Casing method	Sufficient concrete placed to balance the external pressure head before the casing is pulled Clean and undeformed casing
Slurry method	Quality of slurry adequate to be displaced and scoured from the perimeter of the hole by the concrete Clean-out bucket should be used to clean the bottom prior to concreting Maintain tremie 5 to 10 ft below the level of concrete
Underreams	Minimal cuttings in the bottom, or at least 75 to 80 percent of the bottom free of cuttings Adequate bell diameter (check travel of the kelly on the ground surface when the reamer is extended to the proper bell diameter)
Concrete placement	Segregation during placement Avoid pouring concrete through water Adequate slump; avoid hot concrete appearing to set up Maximum aggregate size not too large Excessive water-cement ratio
Reinforcement cage	Resistance to buckling during the concrete pour Full length if casing used Restriction to flow of concrete Restrained from movement during the concrete pour Proper position of cage

PART VI: RECOMMENDATIONS FOR RESEARCH

158. These recommendations are directed toward elimination of unnecessary conservatism in design and improvement in overall reliability and performance of shafts. This overview for design of drilled shaft foundations in cohesive soil consequently indicates that research should be directed toward:

- a. Prediction of load-deflection behavior. Reliable methods for prediction of the complete load-deflection behavior of drilled shafts require much development. Methods that should be investigated include transfer functions and two-dimensional axisymmetric finite element analyses.
- b. Long-term behavior of drilled shafts. Analysis of long-term behavior requires effective stress analysis and field load tests on shafts that have been in place for many years. In situ measurements of lateral earth and pore pressures will be needed.
- c. Uplift resistance. The mechanisms of the uplift resistance to counter effects of swelling soil require understanding. Reliable methods for calculating the uplift resistance are needed.
- d. Prediction of $p - y$ curves. A reliable method of general applicability for predicting $p - y$ curves for analysis of lateral load behavior is needed.
- e. Construction methods. Improvements in construction techniques are needed to reduce construction problems and improve performance of shaft foundations.

REFERENCES

- Baguelin, F. and Jézéquel, J. F. 1978. The Pressuremeter and Foundation Engineering, Trans Tech Publications, Rockport, Mass.
- Bakholdin, B. V. and Berman, V. I. 1974. "Investigations of Negative Skin Friction on Piles and Suggestions on its Calculations," Journal of the Soil Mechanics and Foundation Engineering Division, American Society of Civil Engineers, Vol 11, No. SM4 (English Translation Jan 75), pp 11-15.
- Baligh, M. M. and Vivatrat, V. 1976. "Prediction of Downdrag Loads on Bitumen-Coated Piles," Interim Report 565, Department of Civil Engineering, Massachusetts Institute of Technology, Cambridge, Mass.
- Banerjee, P. K. and Daview, T. G. 1978. "The Behavior of Axially and Laterally Loaded Single Piles Embedded in Nonhomogeneous Soils," Geotechnique, Vol 28, No. 3, pp 309-326.
- Barber, E. S. 1954. "Discussion, Symposium on Lateral Load Tests on Piles," American Society for Testing and Materials, Special Technical Publication, No. 154, pp 96-99.
- Beard, R. M. and Lee, H. J. 1975. "Holding Capacity of Direct Embedment Anchors," Proceedings, Civil Engineering in the Oceans III, Vol I, pp 470-485.
- Bhushan, Kul, Haley, S. C., and Fong, P. T. 1978. "Lateral Load Tests on Drilled Piers in Stiff Clays," Preprint 3248, Spring Convention and Exhibit, American Society of Civil Engineers, Pittsburgh, Pa.
- Bjerrum, L. 1972. "Embankment on Soft Ground," Proceedings, Conference on Performance of Earth and Earth-Supported Structures, American Society of Civil Engineers, Vol 2, Purdue University, Lafayette, Ind.
- Boussinesq, J. 1885. Application of Potential to the Study of the Equilibrium and Movements in Elastic Soils, Gauthier-Villard, Paris.
- Bowles, J. E. 1977. Foundation Analysis and Design, 2nd ed., McGraw-Hill, New York.
- Broms, B. B. 1964. "Lateral Resistance of Piles in Cohesive Soils," Journal of the Soil Mechanics and Foundation Division, American Society of Civil Engineers, Vol 90, No. SM2, pp 27-63.
- Bryant, L. M. and Matlock, H. 1977. "Three-Dimensional Analysis of Framed Structures with Nonlinear Pile Foundations," Ninth Offshore Technology Conference, Houston, Tex., pp 599-606.
- Burland, J. B. 1973. "Shaft Friction of Piles in Clay - A Simple Fundamental Approach," Ground Engineering, Vol 6, No. 3, pp 30-42.
- Burland, J. B., Butler, F. G., and Dunican, P. 1966. "The Behavior and Design of Large Diameter Bored Piles in Stiff Clay," Large Bored Piles, Institute of Civil Engineers, London, pp 51-71.

- Burland, J. B. and Cooke, R. W. 1974. "The Design of Bored Piles in Stiff Clays," Ground Engineering, Vol 7, No. 4, pp 28-35.
- Canadian Geotechnical Society. 1979. "Properties of Soil and Rock," Canadian Foundation Engineering Manual, Part 1, Montreal, Quebec, Canada.
- Chandler, R. J. 1968. "The Shaft Friction of Piles in Cohesive Soils in Terms of Effective Stress," Civil Engineering Public Works Review, Vol 63, pp 48-51.
- Chen, F. H. 1975. Foundations on Expansive Soils, Elsevier Scientific Publishing Company, New York.
- Claessen, A.I.M. and Horvat, E. 1974. "Reducing Negative Friction with Bitumen Slip Layers," Journal, Geotechnical Division, American Society of Civil Engineers, Vol 100, No. GT8, pp 925-944.
- Collins, L. E. 1953. "A Preliminary Theory for the Design of Under-reamed Piles," The South African Institute of Civil Engineers, pp 305-313.
- Coyle, H. M. and Reese, L. C. 1966. "Load Transfer for Axially Loaded Piles in Clay," Journal, Soil Mechanics and Foundation Division, American Society of Civil Engineers, Vol 92, No. SM2, pp 1-26.
- Davie, J. R. and Sutherland, H. B. 1977. "Uplift Resistance of Cohesive Soils," Journal, Geotechnical Engineering Division, American Society of Civil Engineers, Vol 103, GT9, pp 935-952.
- Davis, E. H. and Poulos, H. G. 1972. "Analysis of Pile-Raft Systems," Australian Geomechanics Journal, Vol 62, No. 1, pp 21-27.
- Davisson, M. T. 1970. "Lateral Load Capacity of Piles," Pile Foundations, Highway Research Record No. 133, Highway Research Board, National Research Council, Washington, D. C., pp 104-112.
- Desai, C. S. 1974. "Numerical Design-Analysis for Piles in Sands," Journal, Geotechnical Engineering Division, American Society of Civil Engineers, Vol 100, No. GT6, pp 613-635.
- Desai, C. S., Johnson, L. D., and Hargett, C. M. 1974. "Analysis of Pile Supported Gravity Lock," Journal of the Geotechnical Engineering Division, American Society of Civil Engineers, Vol 100, No. GT9, pp 1009-1029.
- Donaldson, G. W. 1967. "The Measurement of Stresses in Anchor Piles," Fourth Regional Conference for Africa on Soil Mechanics and Foundation Engineering, Cape Town, South Africa, pp 253-256.
- Duncan, J. M. and Chang, C. Y. 1970. "Nonlinear Analysis of Stress and Strain in Soils," Journal, Soil Mechanics and Foundation Division, American Society of Civil Engineers, Vol 96, No. SM5, pp 1629-1653.
- Ellison, R. D., D'Appolonia, Elio, and Thiers, G. R. 1971. "Load-Deformation Mechanisms for Bored Piles," Journal, Soil Mechanics and Foundation Division, American Society of Civil Engineers, Vol 97, No. SM4, pp 661-678.

- Esrig, M. I. et al. 1978. "Initial Development of a General Effective Stress Method for the Prediction of Axial Capacity for Driven Piles in Clay," Geotechnical/Environmental Publication, Vol XI, No. 2, Woodward-Clyde Consultants, San Francisco, Calif., pp 35-45.
- Farmer, G. et al. 1978. "Contractors Viewpoint," Drilled Shaft Design and Construction Seminar, sponsored by Texas State Department of Highways and Public Transportation and Center for Highway Research, University of Texas at Austin, Tex.
- Farr, J. S. 1978. Construction Considerations for the Design of Drilled Shaft and Drilled-and-Underreamed Footings; Training Guide, McClelland Engineers, Inc., Houston, Tex.
- Flaate, K. and Selnes, P. 1977. "Side Friction of Piles in Clay," Proceedings, Ninth International Conference on Soil Mechanics and Foundation Engineering, Vol 1, Tokyo, pp 517-522.
- Gardner, W. S. 1975. "Considerations in the Design of Drilled Piers," Lecture Series on Deep Foundations, Boston Society of Civil Engineers, American Society of Civil Engineers.
- _____. 1977. "Soil Property Characterization in Geotechnical Engineering Practice," Geotechnical/Environmental Bulletin, Vol 10, No. 2, Woodward-Clyde Consultants, San Francisco, Calif.
- Geddes, J. D. 1969. "Boussinesq Based Approximation to the Vertical Stresses Caused by Pile-Type Subsurface Loading," Geotechnique, Vol 19, No. 4, pp 509-514.
- Ghanem, M. F. 1953. "Bearing Capacity of Friction Piles in Deep Soft Clay," PhD Thesis, Department of Civil Engineering, University of Illinois, Urbana, Ill.
- Harr, M. E. 1977. Mechanics of Particulate Media, McGraw-Hill, New York, pp 368-396.
- Harrington, B. P. 1977. "Heave and Downdrag," Proceedings, Institute of Civil Engineering, London, Vol 62, Part 1, pp 717-720.
- Hays, C. O. et al. 1974. "Drilled Shaft Foundation for Highway Sign Structures," Research Report D647F, Engineering and Industrial Experiment Station, University of Florida, Gainesville, Fla.
- Headquarters, Department of the Army. 1948. "Subsurface Investigations - Geophysical Exploration," Engineer Manual 1110-2-1802, Washington, D. C.
- _____. 1961. "Procedure for Foundation Design of Buildings and Other Structures (Except Hydraulic Structures)," Technical Manual 5-818-1, Washington, D. C.
- _____. 1970. "Engineering and Design - Laboratory Soils Testing," Engineer Manual 1110-2-1906, Washington, D. C.
- _____. 1971. "Instrumentation of Earth and Rock-Fill Dams (Groundwater and Pore Pressure Observations - Part 1)," Engineer Manual 1110-2-1908, Washington, D. C.
- _____. 1972. "Soil Sampling," Engineer Manual 1110-2-1907, Washington, D. C.

- _____, 1977. "General Safety Requirements, Engineer Manual 385-1-1, Washington, D. C.
- _____. In publication. "Geophysical Explorations," Engineer Manual 1110-1-1804, Washington, D. C.
- Hetenyi, M. 1946. Beams on Elastic Foundations, University of Michigan Press, Ann Arbor, Mich.
- Hill, J. L. 1981. "User's Guide: Computer Program for Optimal Design and Analysis of Pile Foundations," IR K-81-5, U. S. Army Engineer Waterways Experiment Station, CE, Vicksburg, Miss.
- Holloway, D. M., Clough, G. W., and Vesic, A. S. 1975. "Mechanics of Pile-Soil Interaction in Cohesionless Soil," Contract Report S-75-5, U. S. Army Engineer Waterways Experiment Station, Vicksburg, Miss.
- Holloway, G. L. et al. 1978. "Field Test and Preliminary Design Method for Laterally Loaded Drilled Shafts on Clay," Research Report No. 211-2 (Draft), Texas Transportation Institute, Texas A&M University, College Station, Tex.
- Horvat, E. and Van Der Veen, C. 1977. "Negative Skin Friction and Safety Analysis of Piles," Proceedings, 9th International Conference on Soil Mechanics and Foundation Engineering, Vol 1, Tokyo, pp 551-554.
- Hoy, H. E. 1978. "Current Texas State Department of Highways and Public Transportation (SDHPT) Design Practices for Axial Loading," Drilled Shaft Design and Construction Seminar, sponsored by Texas State Department of Highways and Public Transportation and Center for Highway Research, University of Texas at Austin, Tex.
- Hrennikoff, A. 1950. "Analysis of Pile Foundations with Batter Piles," Transactions, American Society of Civil Engineers, Vol 115, No. 2401, pp 351-381.
- Hui, T. W. 1977. "A Method of Determination of K - The Lateral Earth Pressure Coefficient for Shaft Friction," Ground Engineering, Vol 10, No. 3, pp 22-23.
- Ismael, N. F. and Klym, T. W. 1978. "Behavior of Rigid Piers in Layered Cohesive Soils," Journal, Geotechnical Engineering Division, American Society of Civil Engineers, Vol 104, No. GT8, pp 1061-1074.
- Ito, T. and Matsui, T. 1976. "Negative Skin Friction Acting on Piles," Proceedings, 5th Conference on Soil Mechanics and Foundation Engineering, Budapest, pp 297-311.
- Jain, G. S. and Gupta, S. P. 1972. "Deformation of Soil Around a Multi-Underreamed Pile," The Indian Concrete Journal (Reprint), pp 1-4.
- Janbu, N. 1978. "Static Bearing Capacity of Friction Piles," Sixth European Conference on Soil Mechanics and Foundation Engineering, Vol 1, Part 2, Vienna, pp 479-488.
- Jennings, J. E. and Evans, G. A. 1962. "Practical Procedures for Building in Expansive Soil Areas," The South African Builder, Vol 40, pp 15-23.

Jobes, W. P. and Stroman, W. R. 1974. "Structures on Expansive Soils," Technical Report M-81, U. S. Army Construction Engineering Research Laboratory, Champaign, Ill.

Johnson, L. D. 1979. "Overview for Design of Foundations on Expansive Soils," Miscellaneous Paper GL-79-21, U. S. Army Engineer Waterways Experiment Station, Vicksburg, Miss.

Kaniraj, S. R. and Ranganathem, B. V. 1977. "Drag-Load on Piles in Normally Consolidated Clay," Indian Geotechnical Journal, Vol 7, No. 2, pp 83-105.

Kasch, V. R. et al. 1977. "Design of Drilled Shafts to Support Precast Panel Retaining Walls," Research Report No. 211-1, Texas Transportation Institute, Texas A&M University, College Station, Tex.

Kezdi, A. 1957. "The Bearing Capacity of Piles and Pile Groups," Proceedings, 4th International Conference on Soil Mechanics and Foundation Engineering, London, Vol 2, pp 46-51.

Komornik, A. and Zeitlen, J. G. 1973. "Effect of Swelling Clay on Piles," Proceedings, Eighth International Conference on Soil Mechanics and Foundation Engineering, Moscow, Vol 2, Part II, pp 123-128.

Kondner, R. L. "Bearing Capacity of Friction Pile Group in Cohesive Soil," The Technological Institute, Northwestern University, Evanston, Ill.

Kuhlemeyer, R. L. 1979. "Static and Dynamic Laterally Loaded Floating Piles," Journal of the Geotechnical Engineering Division, American Society of Civil Engineers, Vol 105, No. GT2, pp 289-304.

Kulhawy, F. H., Sangrey, D. A., and Clemence, S. P. 1978. "Direct Embedment Anchors on Sloping Sea Floors - State-of-the-Art," Contract Report No. N62583/77 M R510, for Civil Engineering Laboratory, Naval Construction Battalion Center, Port Hueneme, Calif.

Lambe, T. W., Garlanger, J. E., and Leifer, S. A. 1974. "Prediction and Evaluation of Downdrag Forces on a Single Pile," Research Report R74-27, Soils Publication 339, Department of Civil Engineering, Massachusetts Institute of Technology, Cambridge, Mass.

Lambe, T. W. and Whitman, R. V. 1969. Soil Mechanics, John Wiley, New York.

Leyendecker, E. A. 1978. "Drilling Fluids as Used with Drilled Shaft Construction," Drilled Shaft Design and Construction Seminar unpublished paper presented at, sponsored by Texas State Department of Highways and Public Transportation and Center for Highway Research, University of Texas at Austin, Tex.

Livneh, M., Kinsky, J., and Zaslavsky, D. 1970. "Correlation of Suction Curves with the Plasticity Index of Soils," Journal of Materials, Vol 5, No. 1, pp 209-220.

Long, R. P., and Healy, K. A. 1974. "Negative Skin Friction on Piles," JHR 74-77, Civil Engineering Department, University of Connecticut, Storrs, Conn.

- Martin, D. K., Jones, H. W., and Radhakrishnan, N. 1980. "Documentation for LMVDPILE Program," Technical Report K-80-3, U. S. Army Engineer Waterways Experiment Station, Vicksburg, Miss.
- Matlock, H. and Reese, L. C. 1960. "Generalized Solutions for Laterally Loaded Piles," Journal of the Soil Mechanics and Foundations Division, American Society of Civil Engineers, Vol 86, No. SM5, pp 63-91.
- Mattes, N. S. and Poulos, H. G. 1969. "Settlement of Single Compressible Piles," Journal of the Soil Mechanics and Foundations Division, American Society of Civil Engineers, Vol 95, No. SM1, pp 189-207.
- McAnally, P. 1973. "The Design of Deep Foundations in Expansive Soils in Semi-Arid Areas," Australian Geomechanics Journal, Vol G3, No. 1, pp 15-20.
- McClelland, B. and Focht, J. A., Jr. 1956. "Soil Modulus for Laterally Loaded Piles," Journal of the Soil Mechanics and Foundations Division, American Society of Civil Engineers, Vol 82, No. SM4, pp 1081: 1-22.
- Menard, L. 1957. "Measures In Situ Des Propriétés Physiques Des Sols," Ann. Ponts Chaussées, Vol 14, pp 357-377.
- Meyerhof, G. G. 1955. "Influence of Roughness of Base and Ground-Water Conditions on the Ultimate Bearing Capacity of Foundations," Geotechnique, Vol 5, No. 3, pp 227-241.
- _____. 1956. "Penetration Tests and Bearing Capacity of Cohesionless Soils," Journal of the Soil Mechanics and Foundations Engineering Division, American Society of Civil Engineers, Vol 82, No. SM1, pp 866: 1-19.
- _____. 1976. "Bearing Capacity and Settlement of Pile Foundations," Journal of the Geotechnical Engineering Division, American Society of Civil Engineers, Vol 102, pp 195-228.
- Meyerhof, G. G. and Adams, J. I. 1968. "The Ultimate Uplift Capacity of Foundations," Canadian Geotechnical Journal, Vol 5, No. 4, pp 225-244.
- Mindlin, R. D. 1936. "Force at a Point in the Interior of a Semi-Infinite Solid," Physics, Vol 7, pp 195-200.
- Murphy, D. J. 1972. "The Group Behavior of Piles: A Review," Deep Foundations Lecture Series, Philadelphia, Pa.
- Nair, K. 1967. "Load Settlement and Load Transfer Characteristics of a Friction Pile Subject to a Vertical Load," Proceedings, Third Panamerican Conference Soil Mechanics and Foundation Engineering, pp 565-589.
- Ng, H., Karasudhi, P., and Lee, S. 1976. "Prediction of Negative Skin Friction and Settlement in Piles Due to Fill Surcharge," Geotechnical Engineering, Vol 7, No. 1, pp 25-45.
- Nottingham, L. C. and Grubbs, B. R. 1978. "Application of Cone Penetrometer Tests to Gulf Coast Foundation Studies," Proceedings, Spring Meeting, Texas Section, American Society of Civil Engineers, Corpus Christi, Tex.

- O'Neill, M. W. and Reese, L. C. 1972. "Behavior of Bored Piles in Beaumont Clay," Journal of Soil Mechanics and Foundation Division, American Society of Civil Engineers, Vol 98, No. SM2, pp 195-213.
- O'Neill, M. W. and Ghazzaly, O. I. 1977. "Analysis of Three-Dimensional Pile Groups with Nonlinear Soil Response and Pile-Soil-Pile Interaction," Ninth Offshore Technology Conference, Houston, Tex., pp 245-256.
- Ottaviani, M. and Marchetti, S. 1979. "Observed and Predicted Test Pile Behavior," International Journal for Numerical and Analytical Methods in Geomechanics, Vol 3, No. 2, pp 131-143.
- Parry, R. H. G. and Swain, C. W. 1977a. "Effective Stress Methods of Calculating Skin Friction on Driven Piles in Soft Clay," Ground Engineering, Vol 10, No. 3, pp 24-26.
- _____. 1977b. "A Study of Skin Friction on Piles in Stiff Clay," Ground Engineering, Vol 10, No. 8, pp 33-37.
- Patey, ed. 1977. "Building on Clay," Ground Engineering, Vol 10, No. 8, pp 15-22.
- Poulos, H. G. 1968. "Analysis of the Settlement of Pile Groups," Geotechnique, Vol 13, No. 4, pp 449-471.
- _____. 1971. "Behavior of Laterally Loaded Piles: I- Single Piles," Journal of the Soil Mechanics and Foundation Division, American Society of Civil Engineers, Vol 97, No. SM5, pp 711-731.
- _____. 1972. "Load-Settlement Prediction for Piles and Piers," Journal of Soil Mechanics and Foundations Division, American Society of Civil Engineers, Vol 98, No. SM9, pp 879-897.
- Poulos, H. G. and Davis, E. H. 1973. "Theory of Piles in Swelling and Shrinking Soils," Proceedings, Eight International Conference on Soil Mechanics and Foundation Engineering, Vol 2, Part 2, Moscow, pp 109-176.
- _____. 1974. "Axially Loaded Piles," Elastic Solutions for Soil and Rock Mechanics, John Wiley, New York, pp 269-282.
- _____. 1975. "Prediction of Downdrag Forces in End-Bearing Piles," Journal of the Geotechnical Engineering Division, American Society of Civil Engineers, Vol 101, GT2, pp 189-204.
- Poulos, H. G. and Mattes, N. S. 1969. "Behavior of Axially Loaded End-Bearing Piles," Geotechnique, Vol 19, No. 2, pp 285-300.
- Radhakrishnan, N. and Parker, F., Jr. 1975. "Background Theory and Documentation of Five University of Texas Soil Structure Interaction Computer Programs," Miscellaneous Paper K-75-2, U. S. Army Engineer Waterways Experiment Station, Vicksburg, Miss.
- Randolph, M. F. and Wroth, C. P. 1978. "Analysis of Deformation of Vertically Loaded Piles," Journal of the Geotechnical Engineering Division, American Society of Civil Engineers, Vol 104, No. GT12, pp 1465-1488.

- Reed, R. L. 1978. "Cost Comparison for Drilled Shaft Design vs. Piling," paper presented at Drilled Shaft Design and Construction Seminar, sponsored by Texas State Department of Highways and Public Transportation and Center for Highway Research, University of Texas at Austin, Tex.
- Reese, L. C. 1964. "Load Versus Settlement for an Axially Loaded Pile," Proceedings of the Symposium on Bearing Capacity of Piles, Part 2, Central Building Research Institute, Roorkee, Ind., pp 18-38.
- _____. 1977. "Laterally Loaded Piles Program Documentation," Journal of the Geotechnical Engineering Division, American Society of Civil Engineers, Vol 103, No. GT4, pp 287-305.
- _____. 1978. "Research Relative to Behavior of Drilled Shafts Under Axial Loading," unpublished paper presented at Drilled Shaft Design and Construction Seminar, sponsored by Texas State Department of Highways and Public Transportation and Center for Highway Research, University of Texas at Austin, Tex.
- Reese, L. C. and Allen, J. D. 1977. "Structural Analysis and Design for Lateral Loading," Drilled Shaft Design and Construction Guidelines Manual, Vol II, U. S. Department of Transportation, Federal Highway Administration, Office of Research and Development, Washington, D. C.
- Reese, L. C. and Welch, R. C. 1975. "Lateral Loading of Deep Foundations in Stiff Clay," Journal of the Geotechnical Engineering Division, American Society of Civil Engineers, Vol 101, No. GT7, pp 633-649.
- Reese, L. C., Touma, F. T., and O'Neill, M. W. 1976. "Behavior of Drilled Piers Under Axial Loading," Journal of the Geotechnical Engineering Division, American Society of Civil Engineers, Vol 102, No. GT5, pp 493-510.
- Reese, L. C., Hudson, W. R., and Vijayvergiya, V. N. 1969. "An Investigation of the Interaction Between Bored Piles and Soil," Proceedings, Seventh International Conference of Soil Mechanics and Foundation Engineering, Vol 2, Mexico City, pp 211-215.
- Reese, L. C. and Wright, S. J. 1977. "Construction of Drilled Shafts and Design for Axial Loading," Drilled Shaft Design and Construction Guidelines Manual, Vol 1, Federal Highway Administration, Office of Research and Development, Washington, D. C.
- Roy, N. and Singh, V. 1975. "Stresses in Soils Due to Axially Loaded Friction Pile," Indian Geotechnical Journal, Vol 5, No. 1, pp 21-43.
- Russell, E. R. and Mickle, J. L. 1971. "Correlation of Suction Curves with the Plasticity Index of Soils," Journal of Materials, Vol 6, No. 1, pp 320-331.
- Schmertmann, J. H. 1975. "The Measurement of In Situ Shear Strength," Proceedings, Conference on In Situ Measurement of Soil Properties, American Society of Civil Engineers, Raleigh, N. C., pp 57-180.

Seed, H. B. and Reese, L. C. 1957. "The Action of Soft Clay Along Friction Piles," Transactions, American Society of Civil Engineers, Vol 122, pp 731-753.

Silva, A. S. 1965. "Downdrag on Piles," PhD Thesis, Department of Civil Engineering, University of Connecticut, Storrs, Conn.

Skempton, A. W. 1951. "The Bearing Capacity of Clays," Proceedings, Building Research Congress, Division 1, Part III, London, pp 180-189.

_____. 1953. "The Colloidal Activity of Clays," Proceedings, Third International Conference on Soil Mechanics and Foundation Engineering, Zurich, Vol 1, p 60.

_____. 1959. "Cast-In-Situ Bored Piles in London Clay," Geotechnique, Vol 9, No. 4, pp 153-173.

Snethen, D. R., Johnson, L. D., and Patrick, D. M. 1977. "An Evaluation of Expedient Methodology for Identification of Potentially Expansive Soils," Report No. FHWA-RD-77-94, U. S. Army Engineer Waterways Experiment Station, Vicksburg, Miss., prepared for the Federal Highway Administration, Washington, D. C.

Task Committee for Foundation Design Manual of the Committee on Shallow Foundations. 1972. "Subsurface Investigation for Design and Construction of Foundations of Buildings, Part II," Journal of the Soil Mechanics and Foundations Division, American Society of Civil Engineers, Vol 98, No. SM6, p 566 (ASCE Manual 56, 1976).

Terzaghi, K. 1943. Theoretical Soil Mechanics, John Wiley, New York.

_____. 1955. "Evaluation of Coefficient of Subgrade Reaction," Geotechnique, Vol 5, pp 297-326.

Terzaghi, K. and Peck, R. B. 1967. Soil Mechanics in Engineering Practice, 2nd ed., John Wiley, New York, pp 217-227 and 544-548.

Thorburn, S. and Thorburn, J. Q. 1977. "Review of Problems Associated with the Construction of Cast-In-Place Concrete Piles," PSA Civil Engineering Technical Guide No. 6, Construction Industry Research and Information Association, London.

Tomlinson, M. J. 1951. "The Adhesion of Piles Driven in Clay Soils," Proceedings, Fourth International Conference, Soil Mechanics and Foundation Engineering, London, pp 66-71.

_____. 1975. Foundation Design and Construction, 3rd ed., John Wiley & Sons, New York.

_____. 1977. "Pile Design and Construction Practice," Viewpoint Publication, Cement and Concrete Association, London.

Vesic, A. S. 1977. "Design of Pile Foundations," National Cooperative Highway Research Program, Synthesis of Highway Practice No. 42, Transportation Research Board, National Research Council, Washington, D. C.

Vijayvergiya, V. N. 1977. "Load-Movement Characteristics of Piles," Port 77 Conference, Long Beach, Calif.

- Walker, L. K. and Darvall, P. LeP. 1973. "Dragdown on Coated and Uncoated Piles," Proceedings, Eighth International Conference, Soil Mechanics and Foundation Engineering, Vol 21, Moscow, pp 257-262.
- Watson, J. 1978. "Drilling Equipment," Drilled Shaft Design and Construction Seminar, Sponsored by Texas State Department of Highways and Public Transportation and Center for Highway Research, University of Texas, Austin, Tex.
- Whitaker, T. and Cooke, R. W. 1966. "An Investigation of the Shaft and Base Resistances of Large Bored Piles in London Clay," Large Bored Piles, Institution of Civil Engineers, London, pp 7-49.
- Williams, G. M. J. and Colman, R. B. 1965. "The Design of Piles and Cylinder Foundations in Stiff, Fissured Clay," Proceedings, 6th International Conference on Soil Mechanics and Foundation Engineering, Vol 2, University of Toronto Press, Montreal, pp 347-351.
- Winterkorn, H. F. and Fang, H. Y. 1975. Foundation Engineering Handbook, Van Nostrand-Reinhold, New York, p 602.
- Woodward, R. J., Jr., Gardner, W. S., and Greer, D. M. 1972. Drilled Pier Foundations, McGraw-Hill, New York.
- Wooley, J. A. and Reese, L. C. 1974. "Behavior of an Axially Loaded Drilled Shaft Under Sustained Loading," Research Report 176-2, Center for Highway Research, The University of Texas at Austin, Tex.
- Wright, S. J. and Reese, L. C. 1979. "Design of Large Diameter Bored Piles," Grand Engineering, Vol 12, No. 8, pp 17-19, 21-23, 50-51.
- Wroth, C. P. and Wood, D. M. 1978. "The Correlation of Index Properties with Some Basic Engineering Properties of Soils," Canadian Geotechnical Journal, Vol 15, No. 2, pp 137-145.

APPENDIX A: IN SITU TESTS

1. Engineering properties of subsurface materials often can best be determined from in situ tests, and on occasion these may be the only means by which meaningful results can be obtained. Moreover, costs of taking the necessary number of samples from the soil mass and performing appropriate laboratory tests to determine soil properties needed for design may be high. Nevertheless, in situ test data are not always amenable to simple interpretation. The pore water conditions at the time of the test may differ appreciably from those existing at the time of construction.

2. A general discussion of in situ testing is presented in Engineer Manual 1110-1-1804 (Headquarters, Department of the Army 1980). Analysis of such tests performed on soils, clay shales, and other moisture-sensitive rocks must consider consolidation or expansion that may occur during the test. For example, because of possible consolidation during plate bearing tests or pressuremeter tests, it may be difficult to determine if shear strength test results correspond to unconsolidated-undrained, consolidated-undrained, consolidated-drained, or more likely to strengths intermediate between these limiting states.

3. Types of more useful tests for drilled shaft applications include the standard penetration test (SPT), cone penetration test (CPT), and vane shear, borehole pressuremeter, and field load tests. Results of in situ tests have been correlated with relative density of sands, consistency of clay, and the in situ strength of the soil. Borehole pressuremeter tests are used to determine the in situ lateral modulus of elasticity E_s and coefficient of earth pressure at rest K_0 . Field load tests on full-scale drilled shafts should be performed as part of large projects to determine the axial load-deflection behavior. Brief descriptions of these tests are presented in this appendix.

Standard Penetration Test

4. The SPT measures the number of blows N needed to advance a

standard spoon 1 ft in the soil by driving with a 140-lb hammer and a drop of 30 in. It is described in EM 1110-2-1907 (Headquarters, Department of the Army 1972). The test is of practical importance in that it provides a rough approximation of the relative density of foundation soils and should generally be made when drilled shafts are to be installed. In some areas of the country, correlations have been developed between SPT results and drilled shaft performance (Meyerhof 1956). The split spoon is usually driven a total of 18 in. The penetration resistance is based on the last 12 in., the first 6 in. being necessary to seat the sampler in undisturbed soil at the bottom of the boring.

"Refusal" is usually taken as a blow count of 50 per inch of penetration.

5. Approximate correlations of relative density D_R for noncohesive soils with angle of internal friction ϕ' are available (Task Committee 1972, Schmertmann 1975). The data in Table A1 demonstrate a fair correlation between N and consistency of cohesive soil. SPT data for a given area should be correlated with test data for undisturbed samples on large projects.

Table A1
Correlations Between Consistency and c_u , N , and γ
for Cohesive Soils*

Parameter	Consistency					
	Very Soft	Soft	Medium	Stiff	Very Stiff	Hard
Undrained Strength c_u , tsf	0	0.25	0.5	1.0	2.0	4.0
SPT Blow Count N blows/ft	0	2	4	8	16	32
Unit Wet Weight γ , tcf		0.05-0.06	0.055-0.065		0.06-0.07	

Note: These values should be used as a guide only. Local samples should be tested and the relationship between N and c_u established as $c_u = \beta N$. $\beta = 1/8$ in this table.

* From Foundation Analysis and Design by J. E. Banks. Copyright © 1977, 1968 by McGraw-Hill, Inc. Used with the permission of McGraw-Hill Book Company.

Cone Penetration Test

6. The CPT is essentially a miniature bearing capacity test in which a cone-shaped penetrometer (Figure A1) is pushed into the soil at a slow constant rate. The Dutch cone has been the most popular such device. The pressure required to advance the cone is termed the "penetration resistance." The tip resistance and the combined tip and friction sleeve resistance may both be measured by a load cell mounted on

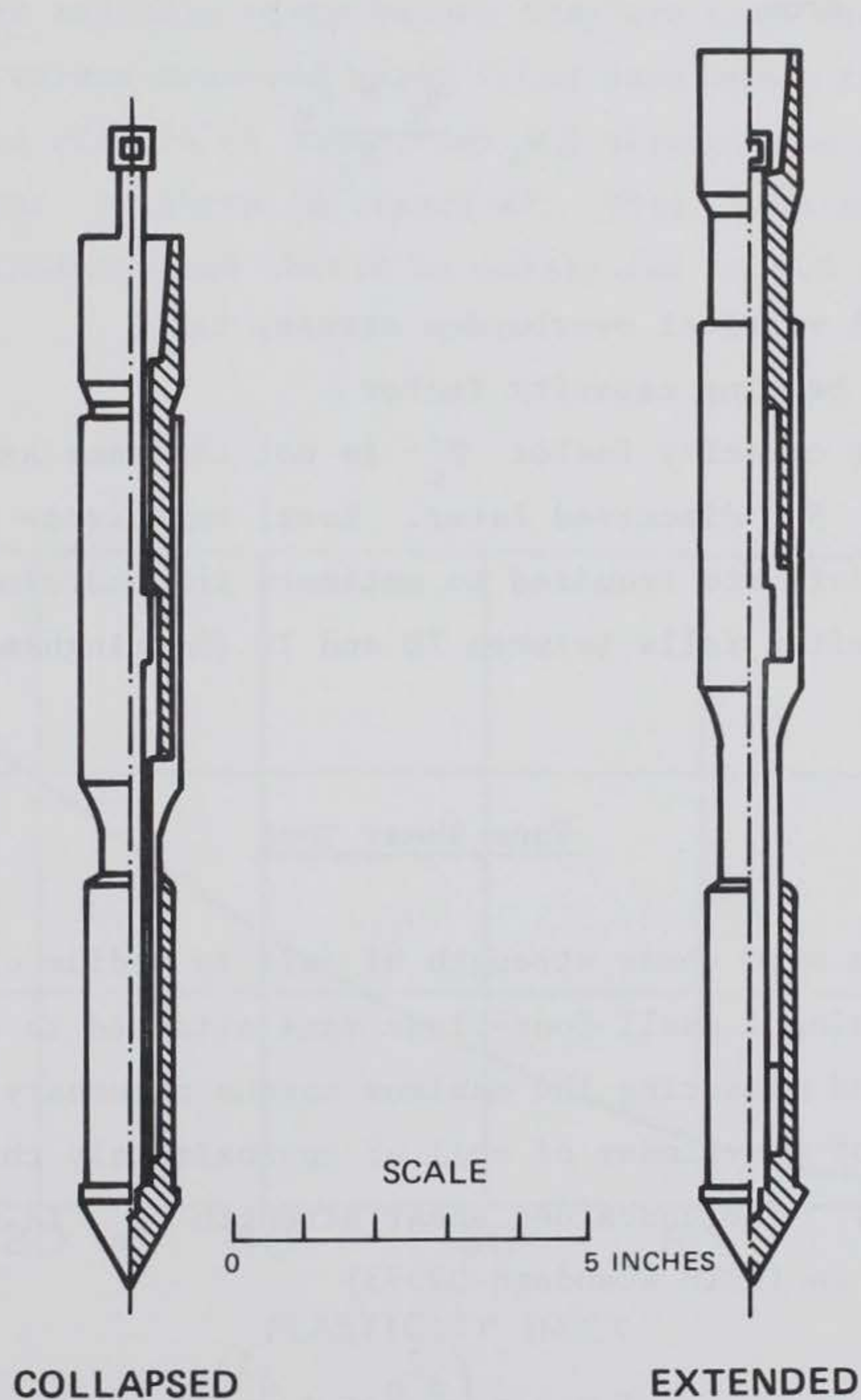

Figure A1. Example of a mechanical friction-cone penetrometer tip (Begemann Friction-cone) (after Nottingham and Grubbs 1978)

top of the inner push rods. After the cone is pushed to the desired depth on the outer rod, force is transferred to the inner rod causing tip movement followed by movement of the tip and the friction sleeve. The penetration resistance q_c has been correlated with relative density of sands and consistency of clays; however, the applicability of the correlations to soil conditions in the United States has not been established.

7. An estimate of the undrained shear strength of the soil c_u may be obtained from

$$c_u = \frac{q_c - \sigma_v}{N'_c} \quad (A1)$$

where

σ_v = total vertical overburden stress, tsf

N'_c = cone bearing capacity factor

The cone bearing capacity factor N'_c is not the same as the bearing capacity factor N_c discussed later. Local experience or correlative shear strength data are required to estimate the undrained shear strength. N'_c often falls between 10 and 20 (Nottingham and Grubbs 1978).

Vane Shear Test

8. The in situ shear strength of soft to medium clays can be measured by pushing a small four-blade vane attached to the end of a rod into the soil and measuring the maximum torque necessary to start rotation (shearing of a cylinder of soil of approximately the dimensions of the vane blades). The undrained shear strength c_u is computed from this torque T as (ASTM standard D2573)

$$T = c_u \pi \left(\frac{d^2 h}{2} + \psi \frac{d^3}{4} \right) \quad (A2)$$

where

d = diameter of vane

h = height of vane

ψ = 2/3 for uniform (usual assumption) end-shear distribution

= 3/5 for parabolic end-shear distribution

= 1/2 for triangular end-shear distribution

The vane shear is best adapted to normally consolidated, sensitive clays having an undrained shear strength of less than 0.25 tsf. The device is not suitable for use in soils containing sand layers, pebbles, or fibrous organic material. Vane tests should be correlated with unconfined compression or other suitable tests before they are used extensively in any area. Strength values measured using field vane shear tests should be corrected for the effects of anisotropy and strain rate using Bjerrum's correlation factor γ shown in Figure A2. This is an average value based on field failures and should be multiplied by 0.8 to obtain a lower limit.

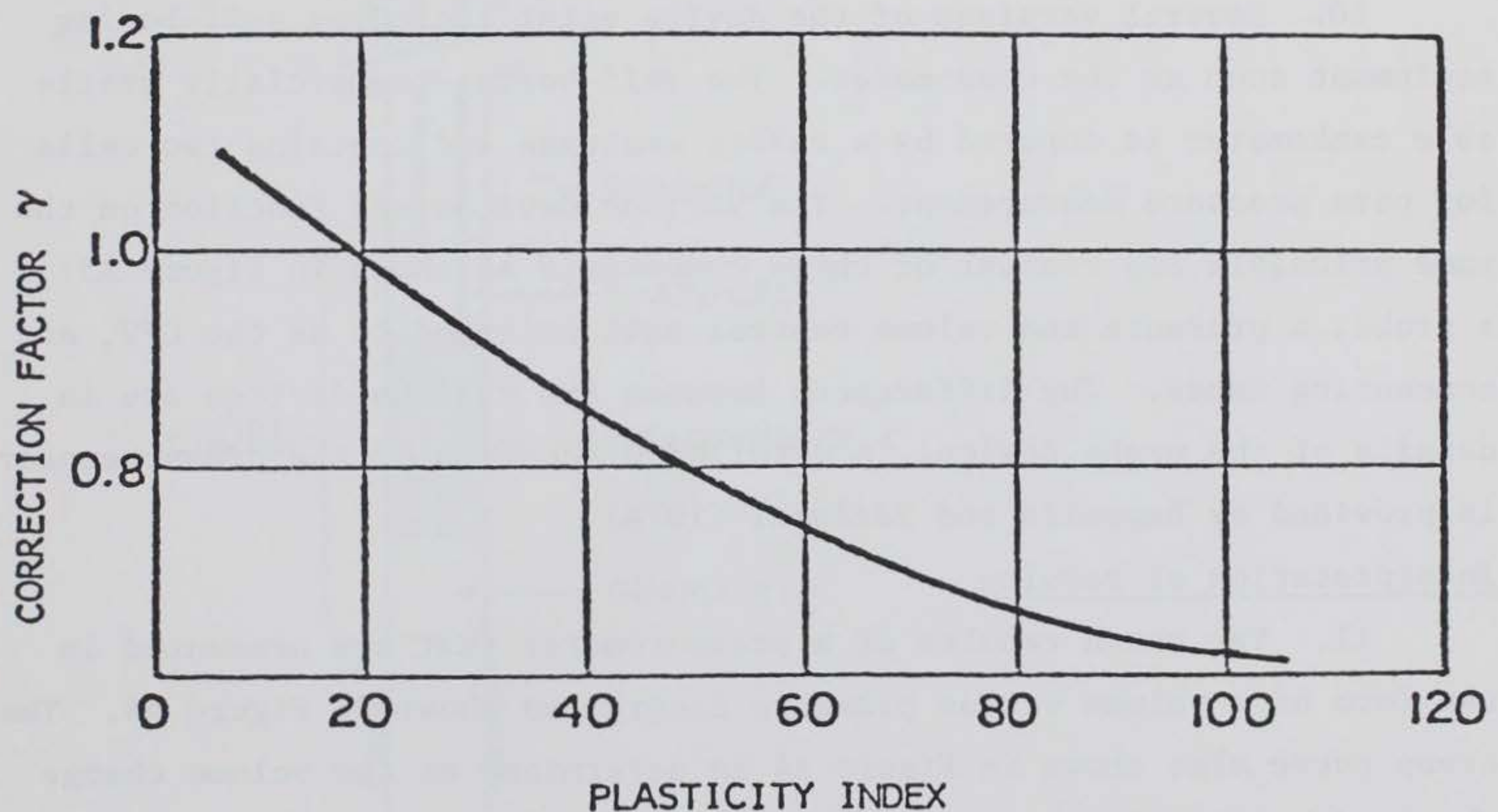

Figure A2. Correlation factor for the vane shear test (after Bjerrum 1972)

Borehole Pressuremeter Test

9. The pressuremeter test developed by Menard (1957) is an in situ loading test carried out in a borehole by means of a cylindrical probe. This test allows the determination of the complete load-deformation characteristics of the tested soil under plane strain conditions. In particular, the following parameters are determined: (a) the pressuremeter deformation modulus representative of the elasticity of the soil, which permits the evaluation of settlements, (b) the limit pressure, related to the shear strength of the soil, from which the bearing capacity of foundations can be computed, (c) in situ stress state and history including coefficient of lateral pressure K_0 and the overconsolidation ratio UCR, and (d) steep rate of strain. Foundation design parameters, e.g., bearing capacity, settlement, and lateral shaft load capacity, can be determined from pressuremeter data.

Equipment

10. Several versions of the device exist including self-boring equipment such as the camkometer. The self-boring commercially available camkometer is covered by a rubber membrane and contains two cells for pore pressure measurement. The various devices all function on the same principle and consist of three components as shown in Figure A3: a probe, a pressure and volume control unit referred to as the CPV, and connecting tubes. The differences between the various devices are in details of the probe design. A detailed discussion of the pressuremeter is provided by Baguelin and Jézéquel (1978).

Interpretation of results

11. The rough results of a pressuremeter test are presented in the form of a volume versus pressure diagram as shown in Figure A4. The creep curve also shown in Figure A4 is determined as the volume change observed between 30 seconds and 1 minute and indicates the quality of the test; i.e., the central portion of this curve should be nearly horizontal, indicating little volume change or nearly elastic soil behavior. The pressure p_i should correspond to the in situ total horizontal stress in the ground. The yield pressure or creep p_f indicates the

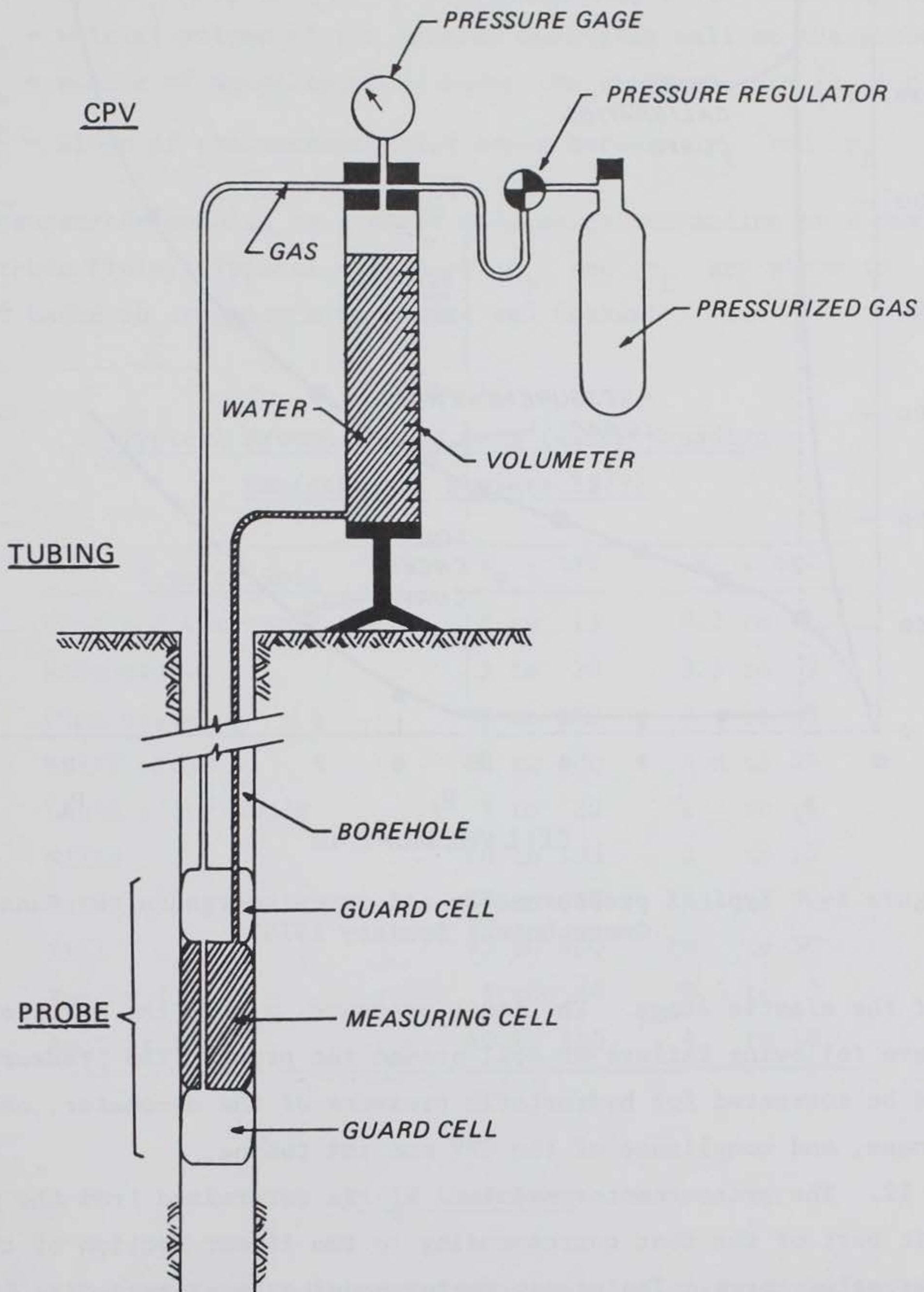

Figure A3. Schematic view of a pressuremeter sketch showing the CPV and probe (after Canadian Geotechnical Society 1979)

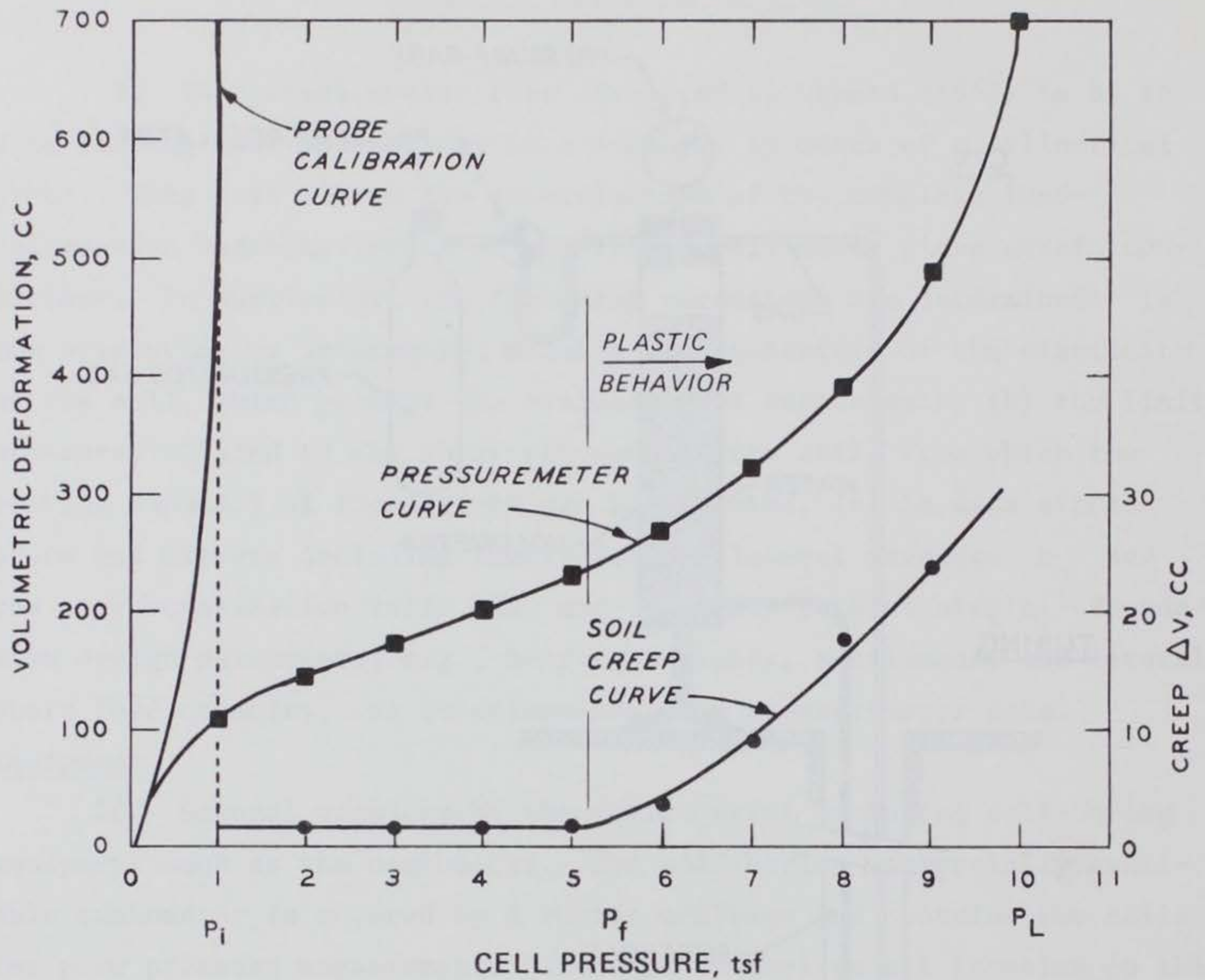

Figure A4. Typical pressuremeter and creep curves (after Canadian Geotechnical Society 1979)

end of the elastic stage. The limit pressure p_L is the asymptotic pressure following failure of soil around the probe. The pressure should be corrected for hydrostatic pressure of the manometer, cell stiffness, and compliance of the CPV and the tubing.

12. The pressuremeter modulus E_p is determined from the pseudo-elastic part of the test corresponding to the linear section of the pressuremeter curve. The pressuremeter modulus is expressed as

$$E_p = 2 (1 + \nu) \left(v_o + v_m \right) \frac{\Delta p}{\Delta V} \quad (A3)$$

where

- ν = Poisson's ratio of the soil (generally taken as 0.33)
 V_o = initial volume of the central measuring cell of the probe
 V_m = volume of water injected under the pressure $p = (p_i + p_f)/2$
 $\frac{\Delta p}{\Delta V}$ = slope of the pressuremeter curve between p_i and p_f

The pressuremeter modulus is a shear modulus corresponding to a deviatoric stress field. Typical values of E_p and p_L are shown in Table A2 based on experience in France and Canada.

Table A2
Typical Pressuremeter Data (After Canadian
 Geotechnical Society 1979)

Type of Soil	E_p , tsf	p_L , tsf
Peat and very soft clays	2 to 15	0.2 to 1.5
Soft clays	5 to 30	0.5 to 3
Firm clays	30 to 80	3 to 8
Stiff clays	80 to 400	6 to 25
Loose silty sands	5 to 20	1 to 5
Silts	20 to 100	2 to 15
Sands and gravels	80 to 400	12 to 50
Till	75 to 400	10 to 50
Recent fill	5 to 50	0.5 to 3
Ancient fill	40 to 150	4 to 10

Field Load Test

13. In situ load tests are often conducted on test shafts as part of a large project. These tests have consistently led to less conservative designs with substantial savings. Standard test methods are available for axial loading of individual or groups of shafts (ASTM Standard D 1143-74). The maximum bearing capacity of the shaft should

be estimated prior to testing to help determine the loading procedure.

14. Figure A5 shows example setups for an axial load test. Loads may be applied using the standard, constant rate of penetration (CRP), or Quick load methods. The standard method usually requires loading in increments of 25 percent of the design load which are to be maintained until the rate of settlement is less than 0.01 in./hour or until 2 hours elapses, whichever occurs first. The maximum loading should exceed two to three times the design load. The CRP method requires 0.01 to 0.05 in./minute deflection for cohesive soils, and loading is varied to maintain these rates. Loading should continue until penetration is at least 15 percent of the shaft diameter. The Quick load test requires loading in 5- to 10-ton increments every 2.5 minutes until continuous jacking is required to maintain the load or until the capacity of the loading equipment is reached. The Quick load test is usually preferred to the standard method because only about 2 to 3 hours is required compared to 7 or 8 days. Effects of consolidation and creep are not measured during the Quick load test.

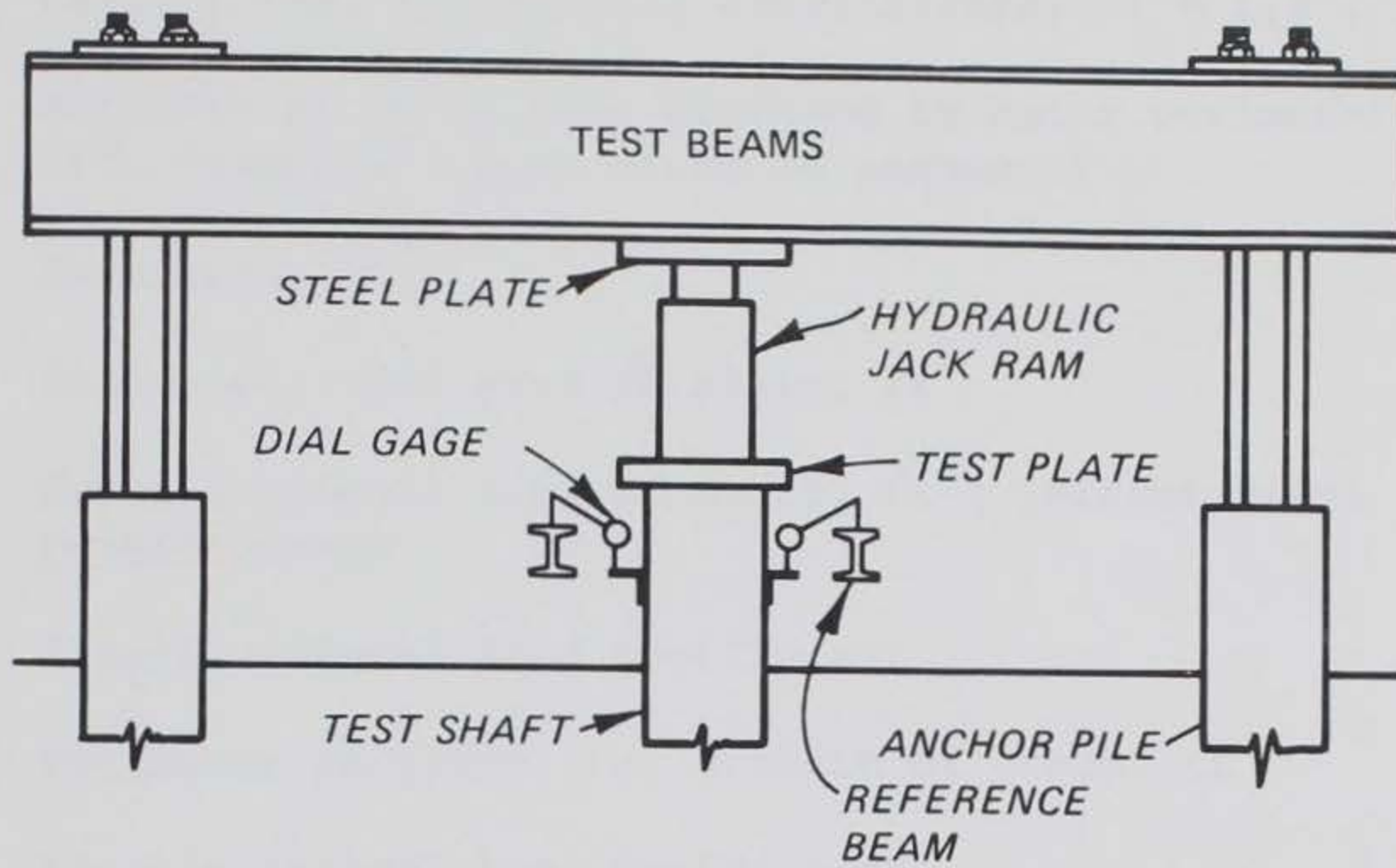

a. With anchored piles

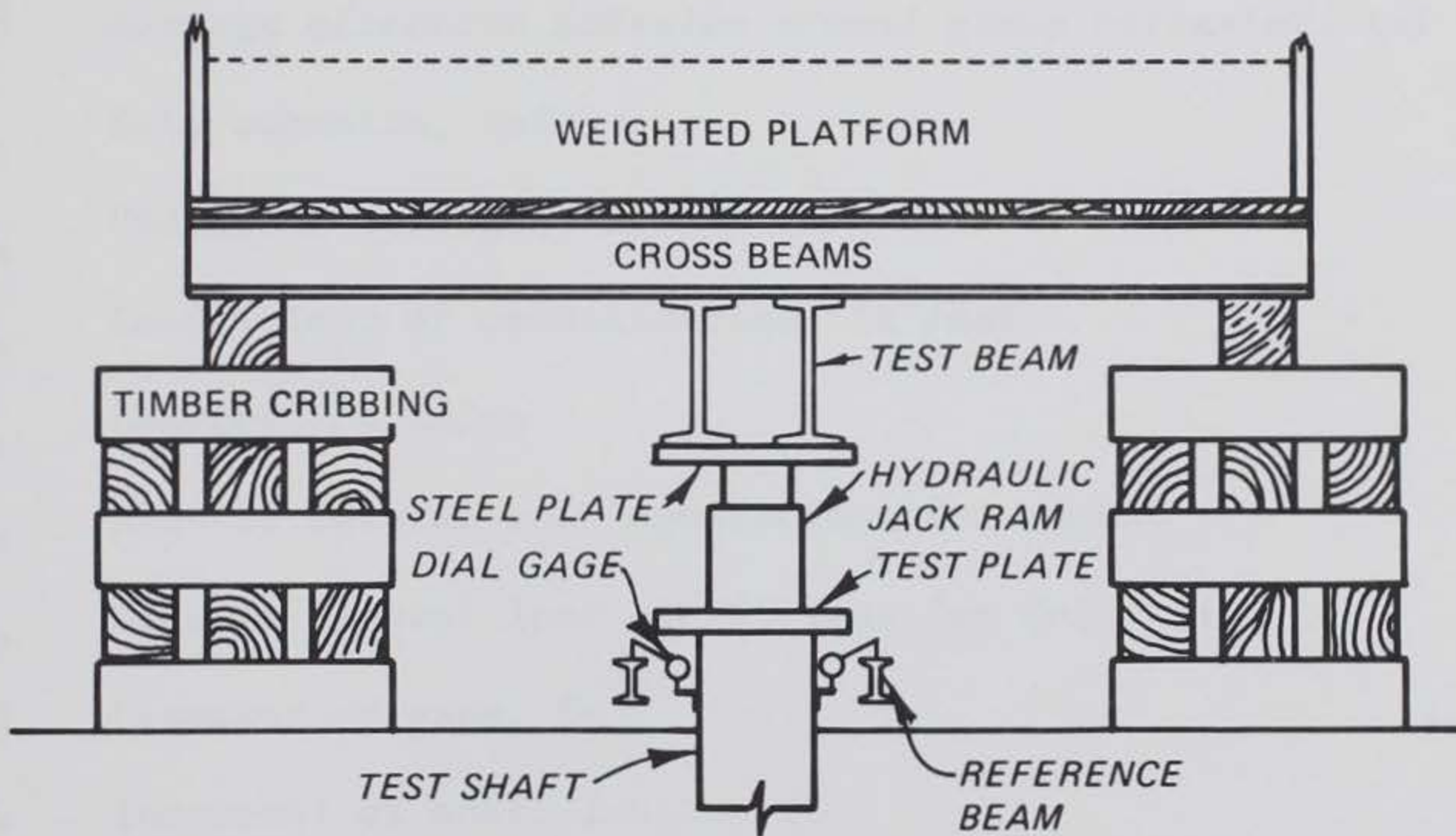

b. With weighted platform

Figure A5. Sketches of test arrangements for applying loads to a drilled shaft (after ASTM D 1143-74)

APPENDIX B: NOTATION

a_{ij}	Lateral load flexibility coefficients, $i = 1, 2 ; j = 1, 2$
A	Activity of soil; area enclosed by outer perimeter of group, ft^2 ; Skempton's pore pressure parameter
A_b	Base area, ft^2
A_p	Cross-sectional area of plate, ft^2
A_s	Cross-sectional area of shaft, ft^2 ; percent steel reinforcement
A_y	Elastic lateral load coefficient
B	Perimeter of group, ft; breadth of group, ft
B_y	Elastic lateral load coefficient
c	Effective cohesion, tsf
\bar{c}	Average effective cohesion around group perimeter, tsf
c_a	Soil adhesion, tsf
c_u	Undrained strength, tsf
c_v	Coefficient of consolidation, ft^2/day
C_c	Compression index
C_m	Elastic lateral load coefficient for moment
C_y	Elastic lateral load coefficient for deflection
d	Diameter of vane, ft
dL	Increment of shaft length, ft
D	Diameter or width of plate, ft
D_b	Diameter of base of shaft, ft
D_s	Diameter of shaft, ft
D_R	Relative density, percent
e	Distance above ground surface, ft

E_c	Young's modulus of concrete, tsf
E_f	Efficiency of group
E_p	Soil modulus from pressuremeter, tsf
E_s	Young's modulus of soil, tsf; soil modulus of shaft reaction, tsf
E_{sb}	Young's modulus of soil beneath the base, tsf
f	Fraction of load carried by base; distance $1.5D_s$ from ground surface to maximum bending moment, ft
f_n	Skin resistance from negative skin friction, tsf
f_s	Skin resistance (friction), tsf
F_c	Pullout resistance factor
FS	Factor of safety
G_s	Shear modulus, tsf
h	Height of vane, ft
H	Thickness of consolidating layer, ft
H_f	Thickness of fill, ft
I	Settlement influence factor (overall); moment of inertia, ft^4
I_l	Settlement influence factors for shaft/base diameter and soil/shaft modulus effects
I_n	Influence load coefficient as function of c_v , E_c/E_s , and time
I_y	Influence factor for deflection
I_{ym}	Influence factor for deflection
I_{yp}	Influence factor for deflection
I_L	Liquidity index
I_θ	Influence factor for rotation
$I_{\theta m}$	Influence factor for rotation

$I_{\theta p}$	Influence factor for rotation
k	Dimensionless shape function; empirical constant
k_b	Base load transfer constant
k_h	Coefficient of horizontal subgrade reaction, tons/ft ³
k_s	Empirical constant
k_{sl}	Coefficient of subgrade reaction for a 1-ft-square plate, tons/ft ³
k_{zz}	Transfer stress function for a point at depth z
k_{∞}	Coefficient of subgrade reaction of infinitely long shaft, tons/ft ³
K	Coefficient of lateral earth pressure; load transfer factor
K_o	Coefficient of lateral earth pressure at rest
K_{IS}	Hyperbolic factor
L	Length of shaft, ft
L_n	Thickness of soil down to the neutral point, ft
m	Factor dependent on overconsolidation ratio; number of shafts along breadth B
m_v	Coefficient of volume change, ft ² /ton
M	Moment at ground surface, ft-tons
M_{yield}	Yield moment of shaft section, ft-tons
n	Number of shafts along width, W ; number of shafts in group; hyperbolic factor
n_h	Soil modulus/depth function
N	Number of blows needed to advance the standard spoon 1 ft in the soil by driving with a 140-lb hammer and a drop of 30 in.
N_c	Dimensionless bearing capacity factor for cohesion
N'_c	Cone bearing capacity factor
N_q	Dimensionless bearing capacity factor for overburden

OCR	Overconsolidation ratio
p	Soil reaction/unit length, tons/ft; average pressure of p_i and p_f , tsf
p_f	Yield pressure from pressuremeter, tsf
p_i	Initial pressure from pressuremeter, tsf
p_L	Asymptotic pressure following failure around probe, tsf
P	Lateral load, tons
P_a	Atmospheric pressure, tsf
P_{design}	Design lateral load, tons
P_r	Resultant force transmitted from retaining wall to supporting shaft, tons
P_u	Ultimate lateral load, tons
PI	Plasticity index
P_θ	Lateral force at height e above ground surface, tons
q_b	Base pressure, tsf
q_{bu}	Ultimate base resistance pressure, tsf
q_c	Cone penetration resistance, tsf
Q	Load on shaft, tons
Q_b	Base resistance, tons
Q_{bu}	Ultimate base resistance, tons
Q_n	Load transferred to shaft from negative skin friction, tsf
Q_{ns}	Ultimate shaft resistance for negative skin friction, tons
Q_r	Force restraining upward thrust or pullout, tons
Q_s	Skin resistance, tons
Q_{su}	Ultimate skin resistance, tons
Q_u	Ultimate capacity of a single shaft, tons

Q_{ug}	Ultimate capacity of a group of shafts, tons
Q_w	Working (safe) load, tons
Q_{yi}	Load on shaft at mobilization of full skin resistance, tons
r	Radius of shaft, ft
R_f	Hyperbolic factor
R_g	Group reduction factor
R_h	Settlement reduction factor for finite soil depth correction
R_k	Settlement reduction factor for pile compressibility correction
R_s	Settlement ratio of group/single shafts
s	Shaft spacing, ft
S_f	Shape of load transfer function
S_v	Skin friction number
T	Relative Shaft Stiffness for variable soil modulus, ft; torque on vane, tons
V_m	Volume of water injected under pressure p , cc
V_o	Initial volume of the central measuring cell of the probe, cc
W	Width of group, ft
X_a	Active depth of volume change of soil, ft
y	Lateral deflection, ft
y_o	Ground line deflection, ft
y_{50}	Lateral deflection at one half of the ultimate lateral load, ft
z	Depth, ft
α	Empirical shear strength reduction factor
α'	Reduction factor for clay consistency

β	Lateral earth and friction angle factor; stiffness function for constant subgrade reaction, ft^{-1} ; coefficient relating blow count N with undrained strength c_u
β_o	Reduction factor to account for part of soil weight carried by shaft
γ	Unit wet weight of soil, tons/ft^3 ; Bjerrum's correlation factor for vane test
γ_c	Unit weight of concrete, tons/ft^3
γ_f	Unit weight of fill, tons/ft^3
$\Delta\rho$	Differential movement between shafts, in.
$\Delta\gamma$	Creep, cc
ϵ	Strain, percent
ϵ_{50}	Strain at one half maximum deviator stress, percent
ζ	Angle of skin friction between soil and concrete, degrees
θ	Rotation, degrees
ν	Poisson's ratio
ρ	Settlement or deflection, in.
ρ_b	Settlement of shaft due to load carried in end bearing, in.
ρ_{bu}	Ultimate settlement of shaft due to load carried in end bearing, in.
ρ_g	Group settlement, in.
ρ_i	Settlement (deflection) for an incompressible pile, in.
ρ_o	Soil settlement at the surface, in.
ρ_s	Shaft movement at depth z , in.
ρ_u	Ultimate settlement, in.
ρ_{yi}	Settlement at mobilization of full skin resistance, in.
σ_v	Total vertical overburden stress, tsf
σ'_v	Effective vertical stress, tsf

σ'_m	Mean normal effective ground stress, tsf
σ_{zz}	Vertical stress at a point 2 in the soil, tsf
σ_3	Lateral confining pressure, tsf
τ	Shear stress at movement ρ , tsf
τ_s	Shear strength, tsf
ϕ'	Effective angle of internal friction, degrees
ϕ_r'	Residual effective angle of internal friction (at large strain), degrees
ψ	Shape of stress distribution of vane test; empirical shear strength reduction factor for use with casing and mud