

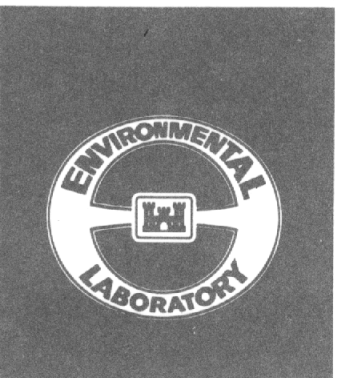

US Army Corps
of Engineers

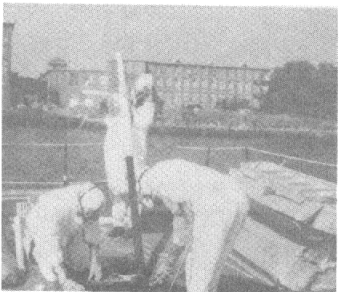
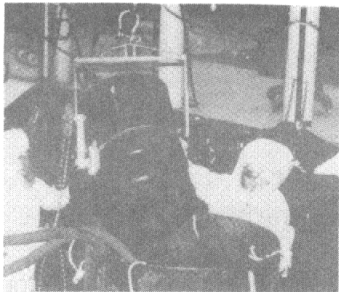

TECHNICAL REPORT EL-88-15

NEW BEDFORD HARBOR SUPERFUND PROJECT, ACUSHNET RIVER ESTUARY ENGINEERING FEASIBILITY STUDY OF DREDGING AND DREDGED MATERIAL DISPOSAL ALTERNATIVES

Report 9

LABORATORY-SCALE APPLICATION OF SOLIDIFICATION/STABILIZATION TECHNOLOGY

by

Tommy E. Myers, Mark E. Zappi

Environmental Laboratory

DEPARTMENT OF THE ARMY
Waterways Experiment Station, Corps of Engineers
PO Box 631, Vicksburg, Mississippi 39181-0631



January 1989

Report 9 of a Series

Approved For Public Release; Distribution Unlimited

Prepared for Environmental Protection Agency
Region 1, Boston, Massachusetts 02203-2211

Unclassified

SECURITY CLASSIFICATION OF THIS PAGE

REPORT DOCUMENTATION PAGE				Form Approved OMB No 0704-0188 Exp Date Jun 30, 1986	
1a. REPORT SECURITY CLASSIFICATION Unclassified		1b. RESTRICTIVE MARKINGS			
2a. SECURITY CLASSIFICATION AUTHORITY		3. DISTRIBUTION/AVAILABILITY OF REPORT Approved for public release; distribution unlimited.			
2b. DECLASSIFICATION/DOWNGRADING SCHEDULE					
4. PERFORMING ORGANIZATION REPORT NUMBER(S) Technical Report EL-88-15		5. MONITORING ORGANIZATION REPORT NUMBER(S)			
6a. NAME OF PERFORMING ORGANIZATION USAEWES Environmental Laboratory		6b. OFFICE SYMBOL (if applicable)	7a. NAME OF MONITORING ORGANIZATION		
6c. ADDRESS (City, State, and ZIP Code) PO Box 631 Vicksburg, MS 39181-0631		7b. ADDRESS (City, State, and ZIP Code)			
8a. NAME OF FUNDING/SPONSORING ORGANIZATION US Environmental Protection Agency, Region 1		8b. OFFICE SYMBOL (if applicable)	9. PROCUREMENT INSTRUMENT IDENTIFICATION NUMBER		
8c. ADDRESS (City, State, and ZIP Code) J. F. Kennedy Federal Building Boston, MA 02203-2211		10. SOURCE OF FUNDING NUMBERS			
		PROGRAM ELEMENT NO.	PROJECT NO.	TASK NO.	WORK UNIT ACCESSION NO
11. TITLE (Include Security Classification) New Bedford Harbor Superfund Project, Acushnet River Estuary, Engineering Feasibility Study of Dredging and Dredged Material Disposal Alternatives; Report 9, Laboratory-Scale Application of Solidification/Stabilization Technology					
12. PERSONAL AUTHOR(S) Myers, Tommy E.; Zappi, Mark E.					
13a. TYPE OF REPORT Report 9 of a series		13b. TIME COVERED FROM Jun 86 TO May 88		14. DATE OF REPORT (Year, Month, Day) January 1989	15. PAGE COUNT 213
16. SUPPLEMENTARY NOTATION Available from National Technical Information Service, 5285 Port Royal Road, Springfield, VA 22161.					
17. COSATI CODES			18. SUBJECT TERMS (Continue on reverse if necessary and identify by block number)		
FIELD	GROUP	SUB-GROUP	See reverse.		
19. ABSTRACT (Continue on reverse if necessary and identify by block number)					
<p>The technical feasibility of applying solidification/stabilization (S/S) technology to sediment from the New Bedford Harbor Superfund Site, New Bedford, MA, was investigated in laboratory studies. Sediment samples from the New Bedford site were solidified/stabilized using three selected processes: a generic process (portland cement), a generic process modified with a proprietary additive (portland cement with Firmix proprietary additive), and a proprietary process (Silicate Technology Corporation proprietary additive). The ability of these processes to eliminate or substantially reduce the pollutant potential of sediment from the New Bedford Harbor Superfund Site was evaluated on the basis of data from physical and chemical tests. Unconfined compressive strength (UCS) was the key test for physical stabilization, and sequential batch leach tests were the key tests for chemical stabilization.</p>					
(Continued)					
20. DISTRIBUTION/AVAILABILITY OF ABSTRACT <input checked="" type="checkbox"/> UNCLASSIFIED/UNLIMITED <input type="checkbox"/> SAME AS RPT. <input type="checkbox"/> DTIC USERS			21. ABSTRACT SECURITY CLASSIFICATION Unclassified		
22a. NAME OF RESPONSIBLE INDIVIDUAL			22b. TELEPHONE (Include Area Code)		22c. OFFICE SYMBOL

18. SUBJECT TERMS (Continued).

Contaminant immobilization	Hazardous waste treatment	Polychlorinated biphenyls
Desorption isotherm analysis	Leach testing	Solidification
Dredged material disposal	New Bedford Harbor	Stabilization

19. ABSTRACT (Continued).

The UCS data showed that New Bedford Harbor sediment can be converted to a hardened mass. Conversion of dredged material from a plastic state to a solid monolith should reduce the accessibility of water to the contaminated solids. The range in 28-day UCS was 20 to 481 psi (0.14 to 3.3 MPa). This range in product strength is indicative of the versatility of solidification as a physical stabilization process for New Bedford Harbor sediment.

Sequential batch leach tests conducted using distilled-deionized water showed that the chemical stabilization properties of the three processes were very similar. Comparison of contaminant masses released during leach testing of solidified/stabilized and untreated sediment showed that the processes reduced the leachability of some contaminants with respect to untreated sediment. The release of cadmium and zinc was eliminated or substantially reduced, and the release of polychlorinated biphenyls (PCBs) during leach testing was reduced by factors of 10 to 100 by all three processes. However, complete chemical stabilization of all contaminants was not achieved. All three processes also mobilized copper and nickel; that is, the release of copper and nickel during leach testing was greater for solidified/stabilized sediment than for untreated sediment. Since chemical stabilization by SS processing was not 100-percent effective, physical stabilization of contaminants by reduced accessibility of water is important for effective contaminant immobilization.

Desorption isotherm analysis was used to compare the contaminant release characteristics of solidified/stabilized and untreated sediments. Desorption isotherm analysis showed that the interphase transfer processes governing contaminant leaching from New Bedford Harbor sediment were substantially altered by S/S processing. The release of PCBs was converted from a desorption process in which leachate PCB concentrations increased during sequential batch leach tests to a desorption process in which the concentrations tended to be constant. Although copper and nickel releases were higher from solidified/stabilized sediment than from untreated sediment, S/S processing converted the release of these metals from a desorption process in which leachate copper and nickel concentrations increased during sequential leaching to a desorption process in which concentrations decreased.

PREFACE

This study was conducted as a part of the Acushnet River Estuary Engineering Feasibility Study (EFS) of Dredging and Dredged Material Disposal Alternatives. The US Army Corps of Engineers (USACE) performed the EFS for the US Environmental Protection Agency (USEPA), Region 1, as a component of the comprehensive USEPA Feasibility Study for the New Bedford Harbor Superfund Site, New Bedford, MA. This report, Report 9 of a series, was prepared at the US Army Engineer Waterways Experiment Station (WES), in cooperation with the New England Division (NED), USACE. Coordination and management support was provided by the Omaha District, USACE, and dredging program coordination was provided by the Dredging Division, USACE. The study was conducted between June 1986 and May 1988.

Project manager for the USEPA was Mr. Frank Ciavattieri. The NED project managers were Messrs. Mark J. Otis and Alan Randall. Omaha District project managers were Messrs. Kevin Mayberry and William Bonneau. Project managers for the WES were Messrs. Norman R. Francingues, Jr., and Daniel E. Averett.

The study was conducted and the report prepared by Messrs. Tommy E. Myers and Mark E. Zappi of the Water Supply and Waste Treatment Group (WSWTG), Environmental Engineering Division (EED), Environmental Laboratory (EL), WES. The Analytical Laboratory Group, EED, under the supervision of Ms. Ann Strong, Chief, assisted with chemical analysis of samples. The Materials and Concrete Analysis Group, Structures Laboratory, WES, under the supervision of Mr. R. L. Stowe, conducted unconfined compressive strength tests on specimens prepared by the WSWTG, EL. Batch leach tests on untreated sediment were conducted by Dr. James M. Brannon, Aquatic Processes and Effects Group, Ecosystem Research and Simulation Division, EL. The report was edited by Ms. Jessica S. Ruff of the WES Information Technology Laboratory.

The study was conducted under the general supervision of Mr. Norman R. Francingues, Jr., Chief, WSWTG; Dr. Raymond L. Montgomery, Chief, EED; and Dr. John Harrison, Chief, EL.

COL Dwayne G. Lee, EN, was Commander and Director of WES and Dr. Robert W. Whalin was Technical Director.

This report should be cited as follows:

Myers, Tommy E., and Zappi, Mark E. 1989. "New Bedford Harbor Superfund Project, Acushnet River Estuary Engineering Feasibility Study; Report 9, Laboratory-Scale Application of Solidification/Stabilization Technology," Technical Report EL-88-15, US Army Engineer Waterways Experiment Station, Vicksburg, MS.

CONTENTS

	<u>Page</u>
PREFACE	1
PART I: INTRODUCTION	4
Background	5
Objectives and Scope	6
PART II: MATERIALS AND METHODS	8
Materials	8
Laboratory Processing	8
Physical/Chemical Testing	9
PART III: SELECTION OF CHEMICAL LEACH TESTS FOR SOLIDIFIED/ STABILIZED NEW BEDFORD HARBOR SEDIMENT	15
Criteria for Selection	15
Technical Approaches of Various Leach Tests	16
Summary of Leach Test Selection	22
PART IV: RESULTS AND DISCUSSION	24
Unconfined Compressive Strength	24
Sediment Chemical Characterization.....	28
Sequential Batch Leach Tests for Untreated Sediment.....	28
Batch Leach Tests for Solidified/Stabilized Sediment.....	41
Limitations of Laboratory Evaluations	77
PART V: ENGINEERING BASIS FOR CONTAMINANT IMMOBILIZATION	79
Primary Containment	79
Secondary Containment	80
Contaminant Transport Models for Solidified/Stabilized Material	81
PART VI: POTENTIAL IMPLEMENTATION SCENARIOS	88
Design Concepts.....	88
Cost.....	92
PART VII: SUMMARY AND CONCLUSIONS	93
Physical Stabilization.....	93
Chemical Stabilization.....	93
Contaminant Immobilization.....	94
REFERENCES	95
APPENDIX A: SEQUENTIAL BATCH LEACH DATA FOR HOT-SPOT SEDIMENT, NEW BEDFORD HARBOR.....	A1
APPENDIX B: SINGLE-STEP AND SEQUENTIAL BATCH LEACH DATA AND DESORPTION ISOTHERMS FOR SOLIDIFIED/STABILIZED SEDIMENTS FROM NEW BEDFORD HARBOR.....	B1

NEW BEDFORD HARBOR SUPERFUND PROJECT, ACUSHNET RIVER ESTUARY
ENGINEERING FEASIBILITY STUDY OF DREDGING AND DREDGED
MATERIAL DISPOSAL ALTERNATIVES

LABORATORY-SCALE APPLICATION OF
SOLIDIFICATION/STABILIZATION TECHNOLOGY

PART I: INTRODUCTION

1. In August 1984, the US Environmental Protection Agency (USEPA) reported on the Feasibility Study of Remedial Action Alternatives for the Upper Acushnet River Estuary above the Coggeshall Street Bridge, New Bedford, MA (NUS Corporation 1984). The USEPA received extensive comments on the proposed remedial action alternatives from other Federal, state, and local officials, potentially responsible parties, and individuals. Responding to these comments, the USEPA chose to conduct additional studies to better define available cleanup methods. Because dredging was associated with all of the removal alternatives, the USEPA requested the Nation's dredging expert, the US Army Corps of Engineers (USACE), to conduct an Engineering Feasibility Study (EFS) of dredging and disposal alternatives. A major emphasis of the EFS was placed on evaluating the potential for contaminant releases from both dredging and disposal operations.

2. The technical phase of the EFS was completed in March 1988. However, as part of Task 8 of the EFS, the results of the study were compiled in a series of 12 reports, listed below.

- a. Report 1, "Study Overview."
- b. Report 2, "Sediment and Contaminant Hydraulic Transport Investigations."
- c. Report 3, "Characterization and Elutriate Testing of Acushnet River Sediment."
- d. Report 4, "Surface Runoff Quality Evaluation for Confined Disposal."
- e. Report 5, "Evaluation of Leachate Quality."
- f. Report 6, "Laboratory Testing for Subaqueous Capping."
- g. Report 7, "Settling and Chemical Clarification Tests."
- h. Report 8, "Compatibility of Liner Systems with New Bedford Harbor Dredged Material Contaminants."

- i. Report 9, "Laboratory-Scale Application of Solidification/Stabilization Technology."
- j. Report 10, "Evaluation of Dredging and Dredging Control Technologies."
- k. Report 11, "Evaluation of Conceptual Dredging and Disposal Alternatives."
- l. Report 12, "Executive Summary."

This report is Report 9 of the series. The results of this study were obtained from conducting EFS Task 6, Element 11 (see Report 1).

Background

3. Solidification/stabilization (S/S) is a state-of-the-art technology for the treatment and disposal of contaminated materials. The technology has been applied in Japan to bottom sediments containing toxic substances (Kita and Kubo 1983, Nakamura 1983, Otsuki and Shima 1982) and in the United States to industrial wastes (Pojasek 1979; Malone, Jones, and Larson 1980; Cullinane, Jones, and Malone 1986). Tittlebaum et al. (1985) reviewed the current technology and its potential application to wastes high in organic contaminants. Although S/S is not the solution of every disposal problem, consideration of this alternative with other viable technologies will ensure that cost-effective technology is used to maximize environmental protection.

4. Solidification is the process of eliminating the free water in a semisolid by hydration with a setting agent(s). Typical setting agents include portland cement, lime, fly ash, kiln dust, slag, and combinations of these materials. Coadditives such as bentonite, soluble silicates, and sorbents are sometimes used with the setting agents to give special properties to the final products. Stabilization can be both physical and chemical. Physical stabilization refers to improved engineering properties such as bearing capacity, trafficability, and permeability. Chemical stabilization is the alteration of the chemical form of the contaminants to make them resistant to aqueous leaching. Solidification usually provides physical stabilization but not necessarily chemical stabilization.

5. Since physical stabilization and solidification are equivalent in terms of the end products, the terms are often used interchangeably, with solidification being the more commonly used term. The literature also uses

the terms "chemical stabilization" and "stabilization" interchangeably, albeit not without some confusion.

6. Solidification (physical stabilization) immobilizes contaminants through the alteration of the physical character of the material. Material converted from a plastic to a solid state is expected to be less susceptible to leaching due to reduced accessibility of water to the contaminated solids within the cemented matrix, and entrapment or microencapsulation of contaminated solids in a dimensionally stable matrix. Since most of the contaminants in dredged material are tightly bound to the sediment phase, physical stabilization is an important contaminant immobilization mechanism (Kita and Kubo 1983).

7. In addition, S/S may chemically stabilize hazardous constituents such that leachability is eliminated or substantially reduced. The S/S processes are usually formulated to minimize the solubility of metals by controlling the pH and alkalinity. Additional metal immobilization can be obtained by modifying the process to include chemisorption (Myers et al. 1985). Anions are typically more difficult to bind in insoluble compounds. Thus, most S/S processes rely on entrapment or microencapsulation to immobilize anions. Some vendors of S/S technology also claim to immobilize organic contaminants. The literature, however, provides no evidence that stabilization of organic contaminants against aqueous leaching occurs using cement and pozzolan-based setting agents (Tittlebaum et al. 1985).

8. The S/S process design is primarily empirical. The state of the art is not sufficiently developed for a process formulation to be designed on the basis of chemical characterization of the material to be solidified/stabilized alone. It is, therefore, necessary to conduct laboratory leach tests to evaluate chemical stabilization effectiveness.

Objectives and Scope

9. The objective of the S/S testing portion of the Acushnet River Estuary EFS of dredging and dredged material disposal alternatives is to evaluate the technical feasibility of chemically stabilizing contaminants in New Bedford Harbor sediments by S/S processing. The technical approach involved laboratory-scale applications of selected S/S processes to Acushnet River Estuary sediment and an evaluation of the solidified/stabilized products on

the basis of physical and chemical properties. The processes evaluated were portland cement, portland cement with Firmix proprietary additive, and Silicate Technology Corporation (STC) (Scottsdale, AZ) proprietary additive.

10. The scope of this report includes descriptions of test methods, presentation and discussion of results from physical strength and chemical leach tests for three S/S technologies, discussion of the engineering basis for contaminant immobilization by S/S technology, and discussion of potential implementation scenarios. Leach testing of untreated hot-spot sediment is included in this report. This study did not include testing of all S/S technologies potentially applicable to New Bedford Harbor sediment, and this report does not compare S/S alternatives for New Bedford Harbor sediment with other alternatives.

PART II: MATERIALS AND METHODS

Materials

11. The estuary composite sediment sample, representing the midrange polychlorinated biphenyl (PCB) concentration in the Upper Estuary portion of the Acushnet River, and the hot-spot sediment sample, representing the higher PCB concentrations in the Upper Estuary, were tested in this study. Collection and preparation of these samples are described in Report 3 of the EFS series. The estuary composite will be referred to as the midrange concentration composite sediment in this report. The contents of each sediment container (208-l drum) were stored at 4° C until used and were mixed immediately before use. No other processing (e.g., dewatering) was applied prior to the application of the various S/S process additives. Type I portland cement was used in the portland cement and portland cement with Firmix processes. Firmix was obtained from Trident Engineering, Baltimore, MD. The S/S reagents for a proprietary silicate process were provided by STC. Interstitial water in the sediment was used to hydrate the setting agents.

Laboratory Processing

12. The process additives were mixed with the sediment in a Hobart C-100 mixer (2.5-gal (9.5-cu dm) capacity) for 5 min per additive. After mixing, the freshly prepared solidified sediment was cast in standard 2-in. (5.1 cm) unconfined compressive strength (UCS) molds for UCS testing and 16-oz. (454-g) plastic cups for curing prior to leach testing.

13. The portland cement and portland cement with Firmix processes were applied in three formulations. The formulations for each process differed with respect to the dosage of setting agent used, not the types of agents used. The portland cement formulations (wet weight sediment basis) were 0.1 portland cement to 1.0 sediment, 0.2 portland cement to 1.0 sediment, and 0.3 portland cement to 1.0 sediment. The portland cement/Firmix formulations were 0.2 portland cement to 0.1 Firmix to 1.0 sediment, 0.15 portland cement to 0.15 Firmix to 1.0 sediment, and 0.1 portland cement to 0.2 Firmix to 1.0 sediment. The STC process was applied in one formulation of 0.3 proprietary additive to 1.0 sediment. The vendor of this process was present during

mixing and preparation of samples to ensure that mixing and handling procedures were appropriate for this process.

Physical/Chemical Testing

14. Unconfined compressive strength was the key test for assessing physical stabilization, and batch leach tests using distilled-deionized water were the key tests for assessing chemical stabilization. A sequential batch leach test was used to evaluate chemical stabilization of metals. Single-step and sequential batch leach tests were used to evaluate chemical stabilization of PCBs. Table 1 lists the batch leach tests used according to S/S process and sediment type.

Sample curing and preparation

15. Samples of solidified/stabilized sediment were cured at 23° C and 98-percent relative humidity in a curing chamber (Hotpack Model 317532). Samples were removed from the molds after the first day. Mechanical problems interrupted humidity control sometime during the first week of curing portland cement and portland cement with Firmix samples. The samples were left in the curing chamber and kept moist with wet towels laid across the top of the samples for the remainder of the cure time. These samples were used for leach tests, but not UCS tests. Inspection of the samples showed that the center was not moist. Additional samples of solidified/stabilized sediment for the portland cement and portland cement with Firmix processes were, therefore, prepared for UCS testing after the chamber was repaired. No problems with the curing chamber were encountered for the second set of samples for the portland cement and portland cement with Firmix processes, and no problems were encountered during curing of samples from the STC process. A standard cure time of 28 days was used in all leach testing. The solidified/stabilized material used in chemical leach testing was crushed prior to leach testing to pass a 2.0-mm sieve and retain on a 0.3-mm sieve.

Unconfined compressive strength

16. The UCS was determined according to the American Society for Testing and Materials Compressive Strength of Hydraulic Cement Mortars (C-109) procedure at approximately 7-, 14-, 21-, and 28-day cure times. Five replicates for the portland cement and portland cement with Firmix processes and three

Table 1
Batch Leach Tests Conducted on Solidified/Stabilized
New Bedford Harbor Sediment

Process	Midrange Sediment		Hot-Spot Sediment	
	Metals	PCBs	Metals	PCBs
Untreated	Seq(7)*	Seq(4)	Seq(5)	Seq(5)
Type I portland cement (PC): sediment (Sed)				
0.1:1**	Seq(4)	Single†	--	--
0.2:1	Seq(4)	Single	--	--
0.3:1	Seq(4)	Single	Seq(5)	Seq(5)
Type I portland cement (PC): Firmix (F):sediment (Sed)				
0.2:0.1:1	Seq(4)	Single	--	--
0.15:0.15:1	Seq(4)	Single	--	--
0.1:0.2:1	Seq(4)	Single	--	--
STC (proprietary additive): sediment (Sed)				
0.3:1	Seq(5)	Seq(5)	Seq(5)	Seq(5)

* Sequential batch leach test (number of leaching steps).

** Weight ratio of additive(s) to wet sediment.

† Single-step batch leach test.

replicates for the STC process were run for each determination. (Sufficient STC proprietary additive was not available to prepare five replicates.)

Sequential batch leaching
of S/S sediment for metals

17. Solidified/stabilized sediments were leached for metals using a sequential leach procedure, similar to the sequential batch leach tests run on untreated midrange concentration composite sediment from New Bedford Harbor and discussed in Report 5 of the EFS series. The leach procedure consisted of contacting crushed solidified sediment samples with distilled-deionized water on a mechanical shaker for 24 hr, separating the leachate from the solidified/stabilized solids by centrifugation and filtration, replacing the leachate with fresh distilled-deionized water, and repeating the shaking-separation procedure. The general procedure is shown in Figure 1. For the midrange

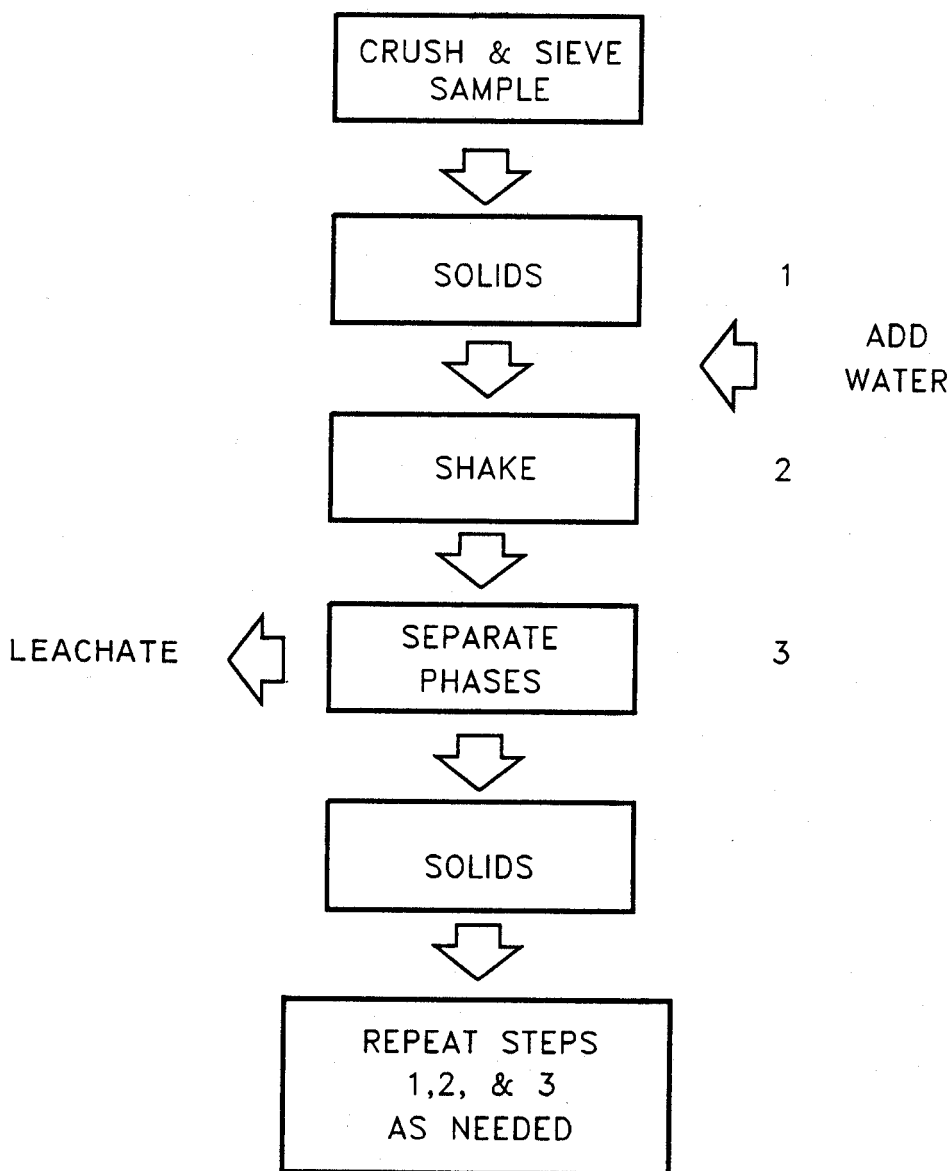

Figure 1. Sequential batch leach test

concentration composite sediment, either four or five steps were used in metal leaching tests (Table 1). A five-step procedure was used to leach solidified/stabilized hot-spot sediment for metals. The tests were run in triplicate in 250-ml polyethylene bottles shaken in the horizontal position. After shaking, the mixtures were centrifuged at 3,000 rpm for 20 min, then filtered through 0.45- μ m membrane filters. Blanks were prepared by carrying deionized-distilled water through the same shaking and filtration procedures. The leachates and blanks were analyzed for cadmium, chromium, copper, lead, nickel, zinc, and dissolved organic carbon (DOC). The leachates and blanks

were preserved with Ultrex nitric acid for metals analysis and with Ultrex hydrochloric acid for DOC analysis. Three replicates were run for metals and DOC sequential leach tests. A composite subsample of the three leachates for each step was analyzed for pH and conductivity.

18. The nominal liquid-to-solids ratio in the first step was 4:1 by weight (100 ml water:25 g wet solidified/stabilized sediment). The actual liquid-to-solids ratio when corrected for the moisture content of the solidified/stabilized sediment was slightly less. Recovery of the water added in the first step of the sequential leach test was not 100 percent due to adsorption of water in the pore spaces within constituent particles. The exact amount adsorbed was determined by weight difference before and after removing the supernate for filtration. The intraparticle adsorption potential for water was satisfied in the first step of the sequential batch leach test. In subsequent steps, practically all of the water added was recovered as leachate. The amount of distilled-deionized water added in subsequent leaching steps was adjusted to maintain a constant liquid-to-solids ratio.

Single-step and sequential batch leaching of S/S sediments for PCBs

19. A single-step batch leach test for PCBs was used to obtain leachate from solidified/stabilized midrange concentration composite sediment processed using portland cement and portland cement with Firmix. The leach procedure consisted of contacting the solidified/stabilized material with distilled-deionized water in 2.2-l glass bottles with Teflon-lined caps on a rotary tumbler (Figure 2). The liquid-to-solids ratio was 1,000 ml water to 250 g solid, or 4:1. After 24 hr on the tumbler, samples were centrifuged at 1,800 rpm for 30 min in glass centrifuge bottles and then filtered through a Whatman GF/D prefilter and a Gelman AE glass fiber filter with a nominal pore size of 1.0 μm . Four replicates were run for each test. Blanks were carried through the leaching and filtering procedure. Leachates were analyzed for total PCB, PCB aroclors, PCB congeners, and DOC.

20. Sequential batch leach tests for PCBs and DOC (four replicates) were run on the solidified/stabilized hot-spot sediment for the portland cement and STC processes using a five-step leach procedure. The procedure involved repeated extraction using distilled-deionized water (Figure 1). As with the sequential leaching for metals, complete recovery of water at the end of the first step was not possible. The amount of distilled-deionized water added at

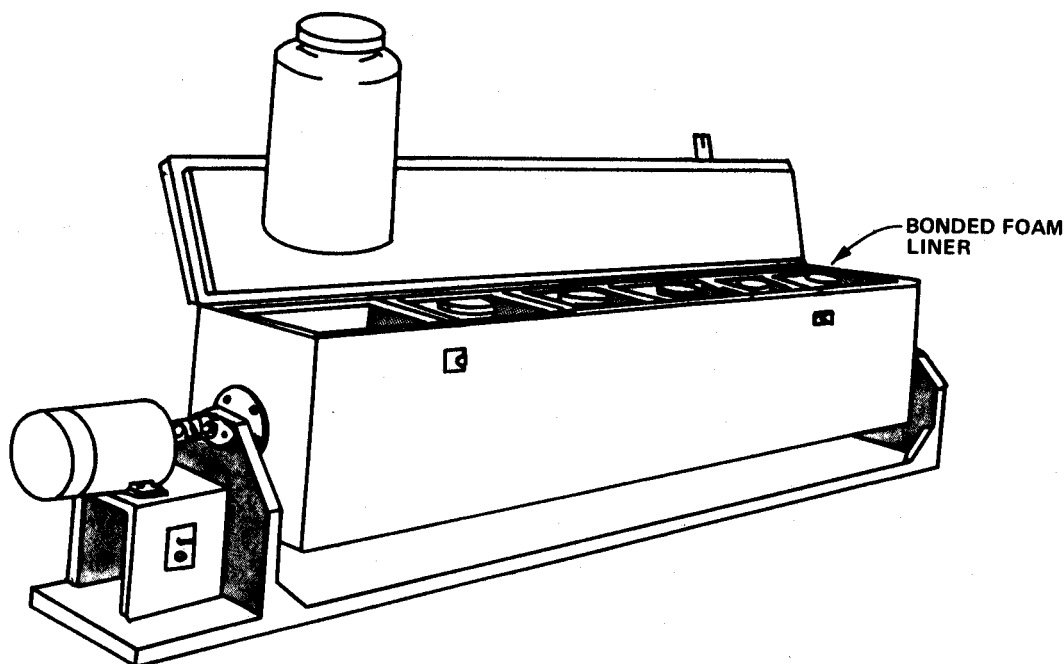

Figure 2. Rotary tumbler

the subsequent steps was adjusted to maintain a constant liquid-to-solids ratio.

Sequential batch leaching of untreated sediment

21. Results from sequential batch leach tests conducted on midrange concentration composite sediment are presented in Report 5 of the EFS series. The data from Report 5 were used in this study to evaluate chemical stabilization effectiveness of S/S for midrange concentration composite sediment.

22. Leach testing of hot-spot sediment was not included in the companion study (Report 5). To develop the baseline information needed to evaluate chemical stabilization effectiveness of S/S for hot-spot sediment, the procedures used in Report 5 were used to sequentially leach (in triplicate) hot-spot sediment for metals and PCBs. The numbers of sequential leach steps used were slightly different (Table 1).

Chemical analysis of leachate samples

23. Leachates, solidified/stabilized sediment, and untreated sediment samples were analyzed for concentrations of PCB Aroclors, total PCB (quantitated using a multi-Aroclor standard), selected PCB congeners, and arsenic,

cadmium, chromium, copper, lead, nickel, and zinc. Concentrations of PCB Aroclors, total PCB, and PCB congeners in treated and untreated sediment samples were determined following soxhlet extraction (50-percent hexane:50-percent acetone), silica gel cleanup, and quantification in a Hewlett Packard 5880A gas chromatograph equipped with a confirmation column and electron capture detectors. Concentrations of PCB compounds in leachate samples following methylene chloride extraction were determined on the same equipment as for sediment samples. Solidified/stabilized sediment, untreated sediment, and leachate samples were analyzed for metals using directly coupled plasma emission spectroscopy on a Beckman Spectraspan IIIB plasma emission spectrometer or by atomic absorption spectroscopy using a Perkin-Elmer Model 5000 atomic adsorption spectrometer coupled with a Perkin-Elmer Model 500 hot graphite atomizer following appropriate sample digestion procedures (Ballinger 1979). Soluble organic carbon was determined on leachate samples using an Oceanographic International 524B organic carbon analyzer.

PART III: SELECTION OF CHEMICAL LEACH TESTS FOR
SOLIDIFIED/STABILIZED NEW BEDFORD HARBOR SEDIMENT

Criteria for Selection

24. To develop the technical input needed for evaluating disposal alternatives that include S/S, it is necessary to investigate the potential for contaminant release from solidified/stabilized material in laboratory leach tests, several of which are available (Lowenbach 1978, Perket and Webster 1981). The available procedures differ substantially in test conditions, theoretical basis for extrapolation of results to the field (Lowenbach 1978, Myers and Hill 1986), and capability for evaluating the chemical stabilization effectiveness of S/S technology. The criteria used to select the type of leach tests to use for solidified/stabilized New Bedford Harbor sediment are discussed below in order of relative importance.

25. Maintaining a chemical environment that simulates important conditions anticipated for disposal of solidified/stabilized New Bedford Harbor sediment is an important criterion for leach test selection. Intentional adjustments in pH, ionic-strength, oxidation-reduction potential, and liquid-to-solids ratio must be carefully evaluated.

26. In addition, a leach test should provide the information needed to determine if S/S processing chemically stabilizes contaminants in New Bedford Harbor sediments. An important aspect of making such a determination is the ability to compare untreated sediment and solidified/stabilized sediment leach data. It is essential that the leach tests conducted on solidified/stabilized sediment produce information that can be compared with results from the leach tests conducted on untreated sediment.

27. The third criterion for leach test selection was the capability for determining the mass fraction of contaminant that has been chemically stabilized. This is an important criterion because the cost-effectiveness of S/S processing is dependent on conversion of leachable contaminant mass to a form that is resistant to aqueous leaching. Thus, a test should measure the contaminant mass fraction that is leachable and the fraction that is resistant to aqueous leaching, and this information must be in a form comparable to equivalent information on the untreated sediment.

28. Because chemical leach tests will be used to make judgments as to the potential effectiveness of contaminant containment provided by S/S technology, there should be a scientific basis for extrapolating the laboratory results to the field. Verified predictive capability, however, was not a criterion for selection because no laboratory leach tests for solidified/stabilized material have been field verified. Some tests by design have theoretical predictive capability, and some do not. The potential for verification was, however, used as part of the selection criteria. Potential predictive capability was evaluated by examining the various test designs for application of mass transport theory.

Technical Approaches of Various Leach Tests

29. Laboratory programs for evaluating S/S technology usually involve one or more of the following types of leach tests: (a) criteria-comparison tests, (b) solid diffusion tests, and (c) sequential batch leach tests. Important aspects of these three types of leach tests are discussed below in relation to the criteria listed above. Emphasis is placed on the scientific basis for using each type.

Criteria-comparison tests

30. Extraction Procedure. The USEPA's Toxic Extraction Procedure (EP) (USEPA 1981) is a criteria-comparison type test in which results from a standardized procedure are compared with a specific set of criteria. The EP was intended to serve as a quick test for identifying wastes that, although not specifically listed in 40 Code of Federal Regulations 261 as hazardous, pose substantial hazard when improperly managed. The test consists of gently stirring dilute acetic acid with approximately 100 g of crushed solidified/stabilized waste for 24 hr in a liquid-to-solids ratio that varies between 16:1 and 20:1 depending on waste alkalinity. The leachate is filtered (0.45- μ m filter), and the contaminant concentrations in the filtered leachate are compared with a published list of limits.

31. The EP was designed for a specific regulatory purpose. In terms of certain test conditions, such as liquid-to-solids ratio and pH, the EP is not a true analog of disposal site conditions, especially conditions anticipated for solidified/stabilized sediment from New Bedford Harbor, since the EP simulates codisposal of solidified/stabilized material in a sanitary landfill.

The pH regime of the EP is inappropriate. Equally important is the difference in the liquid-to-solids ratio used in the EP test and the liquid-to-solids ratio in the field. In porous media systems, such as solidified/stabilized sediment, the liquid-to-solids ratio is approximately 1:1. Batch sorption tests have shown that the distribution of contaminants between the solid and aqueous phases is dependent on the liquid-to-solids ratio (O'Conner and Connolly 1980; Di Toro and Horzempa 1982; Voice, Rice, and Weber 1983; Gschwend and Wu 1985; Di Toro et al. 1986). The literature indicates that distribution coefficients approach a limiting value below a liquid-to-solids ratio of about 10:1, although this is not always the case. It is therefore necessary to use a liquid-to-solids ratio as close to the field liquid-to-solids ratio as possible.

32. Although the EP can be used to compare contaminant release from untreated and solidified/stabilized sediment, the EP provides information on release for only one contact with water. In general, a batch leach test does not extract all of the leachable contaminant mass from the solid phase in the first step. Some of the contaminant remaining will leach in subsequent leaching steps if the solids are sequentially leached. Unless a multiple EP is run involving sequential extraction, the mass fraction of leachable contaminant cannot be determined for all contaminants. For hydrophobic organics, such as PCBs, it is often assumed that the contaminant mass remaining associated with the solid phase at the end of the first extraction will be distributed between solid and aqueous phases in subsequent leach steps according to the distribution observed in the first step (constant partitioning). Sequential leaching is, therefore, not always necessary (Myers, Brannon, and Griffin 1986). However, sequential batch leach tests conducted on untreated New Bedford Harbor sediment have shown that sequential leaching is required for PCBs in New Bedford Harbor sediment (see Report 5).

33. The predictive capability of the EP is weak because the theoretical basis for extrapolating results to the field is weak. The EP was designed on the basis of selected assumptions about the chemical conditions in a sanitary landfill and not in dredged material containment areas. It was not designed on the basis of a mass transport model of leachate generation. The EP does have certain features that argue for its continued use. First, the experience that has been developed with the EP provides a basis for reference. In

addition, the EP has an established regulatory interpretation for solid wastes. Thus, data from EP testing are sometimes needed to satisfy regulatory requirements for information.

34. Elutriate test. The elutriate test developed by the USACE is another criteria-comparison type test. This test was specifically designed to evaluate the acceptability of dredged material for open-water disposal (USEPA 1980a,b). The elutriate test uses a liquid-to-solids ratio of 4:1, an agitation period of 30 min, and 1 hr of settling. The supernate is decanted and filtered (0.45 μm) and analyzed for a variety of water quality parameters, including nutrients, metals, and pesticides. The results are compared with the appropriate water quality criteria using the dilution provided by a mixing zone (if allowed). The test has been modified to predict the quality of effluent discharged from confined dredged material disposal areas (Palermo 1986).

35. The elutriate and modified elutriate tests are similar to the EP in that they are standardized procedures that are fast and relatively simple to conduct and interpret. The elutriate and modified elutriate tests, however, were designed to simulate specific conditions related to hydraulic disposal of untreated dredged material. The liquid-to-solids ratio, agitation time, oxidation-reduction potential, leaching fluid, and other important aspects of the tests were selected to be representative of typical water column conditions for dredged material disposal operations (Jones and Lee 1978, Lee et al. 1978, Palermo 1986). The short agitation period, followed by quiescent settling before phase separation, is not suitable for kinetic or equilibrium batch testing and, to determine the mass fraction of leachable contaminant, a batch test must be interpretable as one or the other. The elutriate and modified elutriate provide information on release for only one contact with water. As previously mentioned, a single-step leach test does not always provide the information needed to determine the contaminant fraction that is leachable. Thus, certain operational aspects of these tests, related to the field conditions the tests were intended to simulate, make them inappropriate for determining the chemical stabilization effectiveness of solidification/stabilization processing of dredged material.

Solid diffusion tests

36. Solid diffusion tests have been used to evaluate S/S of radioactive wastes (Godbee and Joy 1974; Moore, Godbee, and Kibbey 1976) and hazardous

wastes (Coté and Isabel 1984). Solid diffusion tests are static leach tests in which a cured specimen of regular geometry, typically a cylinder, is immersed in water for a specified period of time. At the end of the leaching period, the water is removed for analysis and replaced with a fresh quantity of water. This process is repeated a preselected number of times, depending on anticipated leaching properties. The purpose of a solid diffusion test is to determine the effective solid diffusion coefficient (D_e), an intrinsic property of the solidified/stabilized material that must be determined individually for each contaminant of interest.

37. Solid phase diffusion tests, however, do not provide an unambiguous measure of chemical stabilization. The D_e measured in solid diffusion type tests is a composite property that is dependent on physical factors such as density, effective porosity, and permeability. Thus, the immobilization indicated by a solid diffusion test is a combination of physical and chemical stabilization. In addition, some potential operational problems occur with solid phase diffusion tests when applied to nonradioactive solidified/stabilized materials. Many contaminants will be below detection limits in the leachate generated by this type of test. For radioactive materials, this is not a problem because of the extreme sensitivity of counting techniques for radioactivity.

38. As a material property, D_e can be used to make theoretical predictions of long-term performance for specific disposal scenarios (Moore, Godbee, and Kibbey 1976; Malone, Jones, and Larson 1980). Theoretical predictions are based on the following assumptions about field conditions:

- a. The solidified/stabilized material is a monolith with a continuously smooth external surface area. (Smooth means no cracking, spalling, or erosion.)
- b. Leachate is generated by water in contact with the external surface of the monolith only. Percolation of water through the monolith is negligible.
- c. Contaminant migration is governed by diffusion of contaminant through the solid matrix to the surface of the monolith where solution (leaching) takes place.

39. Solid diffusion type tests are best applied to virtually impermeable solidified/stabilized materials in which diffusion of contaminant to the surface of a monolith is the primary transport mechanism in the solid. Long-term predictions based on the above assumptions can be overly conservative if

water infiltrates the solidified/stabilized material and contaminants are leached by percolating water.

40. Discussion of these limitations is not intended to imply that the diffusive transport approach used in solid diffusion tests does not have a sound theoretical basis. The approach is probably a realistic field model for solidified/stabilized materials that have not deteriorated and have been disposed in such a manner to minimize percolation of water through the solidified/stabilized material.

Sequential batch leach tests

41. Sequential batch leach tests in which leachate is generated as if all internal surfaces were as available for leaching as the external surface of a monolith provide a better approach to determining chemical stabilization effectiveness. The use of loose granular material in an agitated system maximizes surface area and allows the intrinsic contaminant release properties to be isolated from the intergranular and pore phenomena that affect static leaching of a monolith (Nathwani and Phillips 1979). In general, sequential leaching is required if the leachable reservoir of contaminant in solidified/stabilized sediment is to be quantified.

42. In a sequential batch leach test, loose granular material is challenged with successive aliquots of water in an agitated system. After the phases have reached steady state, the phases are separated by centrifugation and/or filtration, and the leachate is analyzed for the contaminants of interest. The solid phase is then reequilibrated with fresh leaching fluid, and the process of phase separation and leachate analysis is repeated. Thus, each step in a sequential batch leach test involves equilibration, phase separation, and leachate analysis.

43. A table of solid phase and aqueous phase concentrations is developed from chemical analysis of the leachates, and these data can be plotted to produce a desorption isotherm. If the desorption isotherms follow classical desorption theory, contaminant-specific coefficients can be obtained that describe the interphase transfer of contaminants from the solid phase to aqueous phase. From these coefficients, the mass fraction of leachable contaminant can be determined.

44. Sequential batch leach tests have been used in previous studies on contaminant release from untreated sediment (Environmental Laboratory 1987; Palermo et al., in preparation) (see also Report 5). These leach tests differ

from the EP and the elutriate tests, which are also batch tests, in terms of test conditions and interpretation. Major differences in test conditions relate to agitation used, shake time, pH control, oxidation-reduction potential, and liquid-to-solids ratio. In the previous tests on untreated sediment, vigorous agitation was used to contact sediment solids with distilled-deionized water until the concentration in each phase reached or approached steady-state values (24 hr). Testing was conducted under nitrogen (anaerobically) to simulate the anaerobic conditions throughout most of a confined disposal facility (CDF) and in the presence of air to simulate the aerobic conditions in the surface crust that forms as a CDF dewateres. A liquid-to-solids ratio of 4:1 was determined to be as close to the field liquid-to-solids ratio as operationally feasible (Environmental Laboratory 1987).

45. Although sequential batch leaching is generally required to determine the contaminant fraction that is leachable, a simplification, the single-step batch equilibrium test, has been the most commonly used procedure for determining sediment and soil distribution coefficients for organic contaminants, especially hydrophobic chemicals such as PCBs. Assuming the agitation time is sufficient for the leachate contaminant concentrations to reach steady state, this type of test is appropriate if all of the contaminant is leachable and the partitioning between solids and aqueous phases is constant. A single-step batch leach test does not measure the mass fraction of leachable contaminant. All the contaminant is assumed to be leachable.

46. The assumptions stated above are implicit in a majority of the published PCB distribution coefficients. Past experiences with contaminated sediments have shown that a single-step batch leach test yields PCB distribution coefficients that are in good agreement with the distribution coefficients obtained by sequential batch leaching of sediment (Myers, Brannon, and Griffin 1986). However, tests on untreated New Bedford Harbor sediment have shown that the partitioning of PCB between solid and aqueous phases is not constant (see Report 5).

47. Sequential batch leach tests and single-step batch leach tests have theoretical predictive capability in that they provide distribution coefficients for permeant-porous media equations. Permeant-porous media equations are mass transport equations that describe the generation of leachate as water percolates through porous media, such as solidified/stabilized sediment.

Caution must be exercised in extrapolating results from a permeant-porous media model that uses distribution coefficients obtained on crushed samples. The surface area for leaching may be significantly less in the field, depending on effective porosity. Further, depending on permeability of the solidified/stabilized material and disposal site conditions, percolation may not be the primary contaminant transport mechanism. Other modeling approaches, such as the solid diffusion approach previously discussed, may provide a more realistic assessment of contaminant mobility.

Summary of Leach Test Selection

48. The criteria-comparison type leach tests discussed above may be satisfactory for their intended purposes, but they are not suitable for determining the capability of a S/S process to chemically stabilize contaminated sediment because (a) certain test conditions are inappropriate for evaluating solidified/stabilized sediment and (b) the amount of leachable contaminant remaining at the end of the tests cannot be determined from the data obtained. Solid diffusion type leach tests are not appropriate for determining the capability of S/S to chemically stabilize contaminated sediment because these tests do not separate the effects of physical and chemical stabilization and are not suitable for testing untreated sediment.

49. Sequential batch leach tests were selected for evaluating chemical stabilization of metals because these tests can be used to determine the leachable mass fraction, and they can be conducted on untreated and solidified/stabilized sediment. A single-step batch leach test was selected for evaluating chemical stabilization of PCBs in the midrange concentration composite sediment solidified/stabilized using portland cement and portland cement with Firmix processes because previous work with contaminated sediments indicated that this test could provide a simple method for obtaining essentially the same information provided by a sequential batch leach test. Because sequential batch leach data for untreated New Bedford Harbor sediment were not available when leach testing of the solidified/stabilized sediment was initiated, the potential limitations of a single-step procedure for estimating PCB leachability from untreated and solidified/stabilized New Bedford Harbor sediment were not known. This information was available, however, before the leach tests on the STC process and the hot-spot sediment were

initiated. A sequential batch leach procedure was, therefore, selected for evaluating chemical stabilization of PCBs by the STC process for midrange concentration composite sediment and hot-spot sediment. A sequential batch leach procedure was also used to leach hot-spot sediment that had been solidified/stabilized using portland cement.

PART IV: RESULTS AND DISCUSSION

Unconfined Compressive Strength

50. Unconfined compressive strength for portland cement, portland cement with Firmix, and STC process formulations was measured at cure times of approximately 7, 14, 21, and 28 days. These data are presented in Figures 3 and 4 for portland cement and portland cement with Firmix processes and for selected 0.3 additive to 1.0 sediment formulations for all three processes in Figure 5. Each point on the UCS versus cure time curves for the portland cement and portland cement with Firmix processes is the average of the five UCS measurements, and the points on the STC curve are averages for three measurements. The gain in strength with cure time for all of the process formulations, with the exception of the 0.1 portland cement to 1.0 sediment formulation, showed that the sediment solidified in spite of the potential for interference from the various contaminants in the sediment. If the setting reactions responsible for solidification were not occurring, the products would not gain strength as they cured. The strength versus cure time curves show no evidence of delayed or retarded set. This is a significant finding in light of what is known about the potential for contaminant interference on setting reactions (Jones et al. 1985).

51. The portland cement (PC) data (Figure 3) showed that the higher the portland cement dosage, the higher the strength of the solidified product. The 0.3 portland cement to 1.0 sediment formulation had the highest 28-day UCS for the portland cement formulations at 277 psi (1.9 MPa). Strengths for the portland cement with Firmix process formulations (Figure 4) were generally higher than the strengths for the portland cement formulation with an equal amount of setting reagent (0.3 portland cement to 1.0 sediment formulation). Substitution of Firmix for cement improved the physical strength of the solidified/stabilized product. Of the portland cement and portland cement with Firmix formulations, the 0.15 portland cement to 0.15 Firmix to 1.0 sediment formulation had the highest 28-day UCS (380 psi, 2.6 MPa). The UCS versus cure time curves for 0.3 STC to 1.0 sediment, 0.3 portland cement to 1.0 sediment, and 0.15 portland cement to 0.15 Firmix to 1.0 sediment are shown in Figure 5. As shown in Figure 5, the highest strengths were

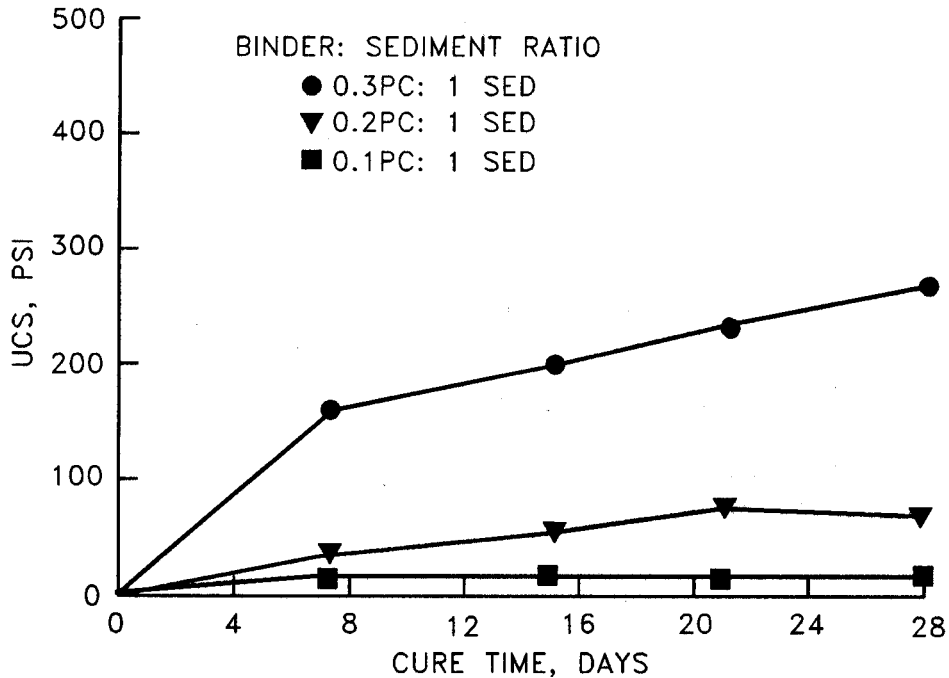

Figure 3. Unconfined compressive strength versus cure time for midrange concentration composite sediment solidified with Type I portland cement (to convert pounds (force) per square inch to megapascals, multiply by 0.006894757)

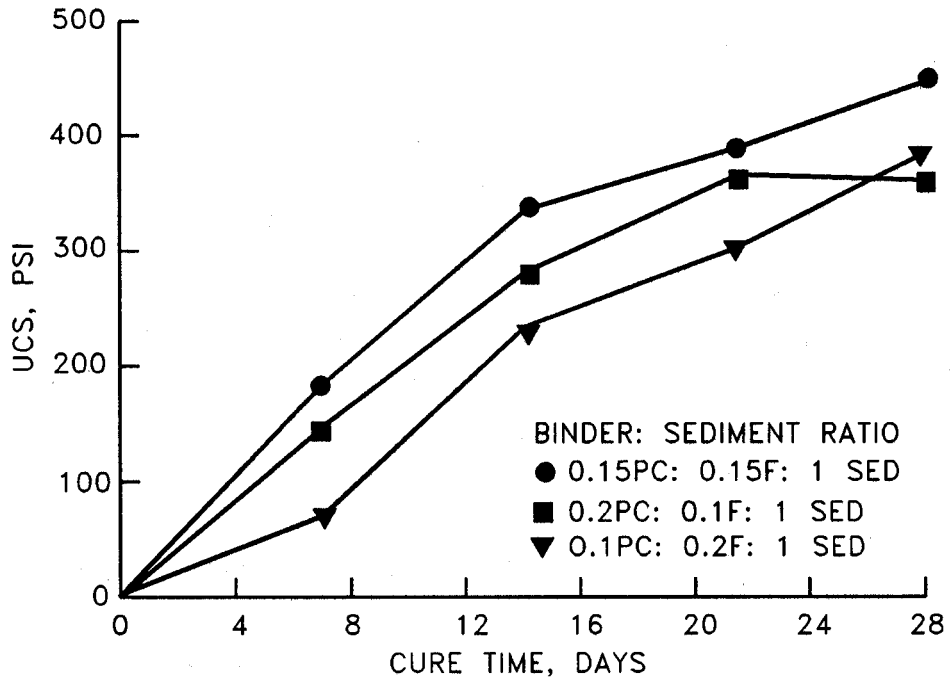

Figure 4. Unconfined compressive strength versus cure time for midrange concentration composite sediment solidified with Type I portland cement with Firmix

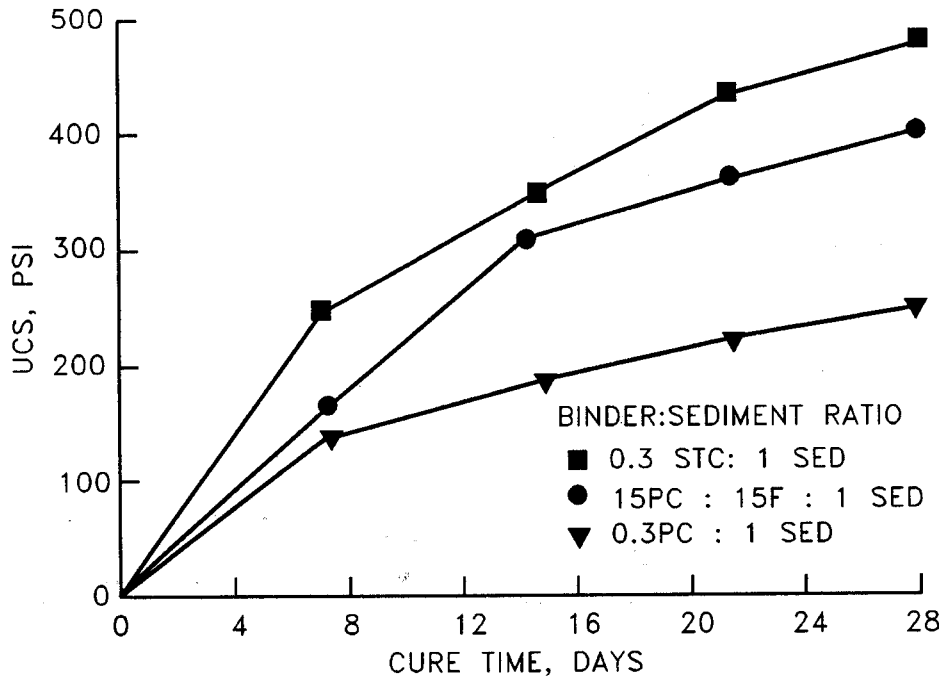

Figure 5. Solidified/stabilized midrange concentration composite sediment unconfined compressive strength versus cure time curves for 0.3 additive(s):1.0 sediment formulations

obtained with the STC process. The 28-day UCS for the STC process was 481 psi (3.3 MPa).

52. Strengths at the 28-day cure time were fairly low, less than 500 psi (3.4 MPa), compared with concrete. For comparison, the unconfined compressive strengths of various concretes, clays of various consistency, and solidified industrial sludges are shown in Table 2. Solidified/stabilized New Bedford Harbor sediments had strengths that were above the range normally associated with hard clays and solidified industrial sludges, but lower than the range normally associated with low-strength concretes.

53. A policy directive issued by the USEPA Office of Solid Waste and Emergency Response (OSWER) (USEPA 1986) established a minimum UCS of 50 psi (344 kPa) as indicative of satisfactory solidification of hazardous liquids. The 50-psi UCS is used to determine if the processing of hazardous liquids prior to landfilling involves primarily "sorbents" (materials that hold liquids by surface and capillary tension) or solidification/stabilization reagents (materials that chemically react with aqueous liquids to produce a hardened mass). In all cases, except for the 0.1 portland cement to

Table 2
Unconfined Compressive Strengths of Various Materials

<u>Material</u>	<u>Type</u>	<u>Unconfined Compressive Strength psi*</u>
Clay	Very soft	<3.5
	Soft	3.5-7
	Medium	7-14
	Stiff	14-28
	Hard	28-56
	Very hard	56
Concrete	Low-strength	2,000
	Medium-strength	5,000
Soil-like solidified waste (Bartos and Palermo 1977)	FGD** sludge	23-43
	Electroplating sludge	32
	Nickel/cadmium battery sludge	8
	Brine sludge	22
	Calcium fluoride sludge	25

* To convert pounds (force) per square inch to kilopascals, multiply by 6.894757.

** Flue-gas desulfurization.

1.0 sediment process, UCS measurements for solidified/stabilized New Bedford Harbor sediment exceeded the OSWER minimum value.

Sediment Chemical Characterization

54. Heavy metal concentrations in midrange concentration composite and hot-spot sediment samples from New Bedford Harbor are presented in Table 3. Copper, lead, and zinc are the most abundant metals in New Bedford Harbor sediment. The concentrations for these metals (Table 3) exceed those normally encountered in most dredged material (Brannon, Plumb, and Smith 1980). Except for zinc, the metal concentrations in the hot-spot sample were lower than in the midrange concentration composite sediment sample. The differences in metal concentrations were relatively minor, except for lead. The hot-spot sediment lead concentration was approximately one half the lead concentration in the midrange concentration composite sediment sample. Concentrations of PCB Aroclors, total PCB (PCB quantified with a multi-Aroclor standard), and selected PCB congeners in midrange concentration composite and hot-spot sediments are presented in Table 4 (see Table 5 for PCB congener identification key). On the whole, the hot-spot sediment is approximately five times more contaminated with PCBs than the midrange concentration composite sediment.

Sequential Batch Leach Tests for Untreated Sediment

55. Report 5 presents results from several types of batch leach tests for midrange concentration composite sediment from New Bedford Harbor. The tests showed that a 24-hr shaking time was sufficient to attain steady-state contaminant leachate concentrations for most metals and all PCBs. Sequential batch leach tests conducted by contacting anaerobic sediment with successive inputs of distilled-deionized water showed that as sequential leaching proceeded, leachate contaminant concentrations increased. For all of the metals except arsenic, the highest leachate concentration was observed after several steps in the leaching sequence. Desorption isotherms developed from the sequential batch leach data had negative slopes with an apparent turn toward classical linear desorption toward the end of the leaching sequence for

Table 3
Concentration of Metals in New Bedford Harbor Sediments

Metal	Concentration, mg/kg Dry Weight			
	Midrange Composite*		Hot-Spot**	
Arsenic	8.66	(0.24)†	NT††	--
Cadmium	35.4	(0.25)	36.2	(0.62)
Chromium	754	(9)	545	(5.8)
Copper	1,730	(21)	1,328	(14)
Lead	2,013	(239)	1,011	(8.9)
Mercury	2.59	(0.03)	NT	--
Nickel	122	(1.8)	90	(1.3)
Selenium	<0.49		NT	--
Zinc	3,017	(22)	3,364	(52)

* From Report 5 (three replicates).

** This study (five replicates).

† Standard error in parentheses.

†† Not tested.

Table 4
PCB Concentrations in New Bedford Harbor Sediments

Parameter*	Concentration, mg/kg Dry Weight	
	Midrange Composite**	Hot-Spot†
C7	0.56 (0.01)††	3.08 (0.18)
C8	166 (3.8)	688 (171)
C28	153 (5.3)	738 (177)
C44	84.1 (3.5)	310 (29)
C49	28.0 (0.85)	233 (157)
C50	153 (5.3)	536 (61)
C52	177 (9.3)	522 (56)
C70	59.2 (3.3)	199 (22)
C77	147 (3.4)	<0.01 --
C82	24.3 (1.2)	<0.01 --
C87	8.2 (0.41)	24.6 (2.3)
C97	22.9 (1.1)	474 (38)
C101	70.4 (4.3)	424 (35)
C105	36.7 (0.88)	<0.01 --
C118	29.6 (1.3)	326 (54)
C136	17.1 (0.53)	112 (24)
C138	25.1 (0.61)	148 (24)
C143	24.7 (0.88)	159 (24)
C153	56.7 (3.1)	288 (44)
C155	50.0 (1.0)	108 (47)
C167	19.2 (2.8)	79.4 (18)
C180	7.94 (1.6)	19.4 (1.7)
C185	<1	48.4 (12)
Aroclor 1242	887 (67)	5,700 (510)
Aroclor 1254	662 (62)	2,700 (228)
Total PCB	2,167 (34)	7,680 (637)

* See Table 5 for PCB congener identification key.

** From Report 5 (three replicates).

† This study (five replicates).

†† Standard error in parentheses.

Table 5

PCB Congener Identification Key Used in This Report

<u>IUPAC* Number</u>	<u>Compound</u>
C7	2,4-dichlorobiphenyl
C8	2,4'-dichlorobiphenyl
C28	2,4,4'-trichlorobiphenyl
C44	2,2',3,5'-tetrachlorobiphenyl
C49	2,2',4,5',-tetrachlorobiphenyl
C50	2,2',4,6-tetrachlorobiphenyl
C52	2,2',5,5'-tetrachlorobiphenyl
C70	2,3',4',5-tetrachlorobiphenyl
C77	3,3',4,4'-tetrachlorobiphenyl
C82	2,2',3,3',4-pentachlorobiphenyl
C87	2,2',3,4,5'-pentachlorobiphenyl
C97	2,2',3',4,5-pentachlorobiphenyl
C101	2,2',4,5,5'-pentachlorobiphenyl
C105	2,3,3',4,4'-pentachlorobiphenyl
C118	2,3',4,4',5-pentachlorobiphenyl
C136	2,2',3,3',6,6'-hexachlorobiphenyl
C138	2,2',3,4,4',5'-hexachlorobiphenyl
C143	2,2',3,4,5,6'-hexachlorobiphenyl
C153	2,2',4,4',5,5'-hexachlorobiphenyl
C155	2,2',4,4',6,6'-hexachlorobiphenyl
C167	2,3',4,4',5,5'-hexachlorobiphenyl
C180	2,2',3,4,4',5,5'-heptachlorobiphenyl
C185	2,2',3,4,5,5',6-heptachlorobiphenyl

* International Union of Pure and Applied Chemists.

some contaminants, in particular, PCBs. These data indicate that the distribution of metals and PCBs between solid and dissolved phases was nonconstant, and distribution coefficients decreased as contaminant was removed from the sediment solids. Thus, classical linear desorption did not model the release of contaminants from midrange concentration composite sediment.

56. Classical linear desorption takes one of the forms shown in Figure 6, depending on the leachability of the bulk sediment contaminant mass. The desorption isotherm in Figure 6 that intersects the ordinate (y-axis) represents a contaminant for which a fraction of the bulk sediment contaminant mass is resistant to aqueous leaching. Since a fraction of bulk sediment metal concentrations is associated with geochemical phases that are resistant to aqueous leaching (Brannon et al. 1976; Brannon, Plumb, and Smith 1980), metal desorption isotherms can be expected to intersect with the ordinate. This type of desorption isotherm has been used to model metal desorption from contaminated sediment (Environmental Laboratory 1987). There may also be a leaching-resistant component for PCBs (Di Toro and Horzempa 1982, DiToro et al. 1986). However, the physical basis for a nonreversibly sorbed component for organic contaminants is not as well established as the geochemical partitioning basis for metals. The desorption isotherm in Figure 6 that intersects with the origin (0,0) represents a contaminant that is completely leachable. This type of desorption has been used to model PCB desorption from contaminated sediment (Environmental Laboratory 1987). Figures 7 and 8 are desorption isotherms obtained from sequential batch leaching of midrange concentration composite sediment for zinc and Aroclor 1254, respectively. Departure from classical linear desorption is clearly evident in Figures 7 and 8 because the dissolved contaminant concentrations increase instead of decreasing as the sorbed contaminant concentrations decrease.

57. Hot-spot sequential batch leach data and desorption isotherms are presented in Appendix A. The sequential batch leach tests conducted on hot-spot sediment generally confirmed the results obtained for the midrange concentration composite sediment. Metal desorption isotherms, except lead, again had negative slopes (Table 6). All PCB desorption isotherms had negative slopes (Table 7). Thus, desorption of metals and PCBs from hot-spot sediment did not follow the classical (positive slope) linear desorption model. The PCB desorption isotherms for hot-spot sediment (Appendix A) showed, as did the

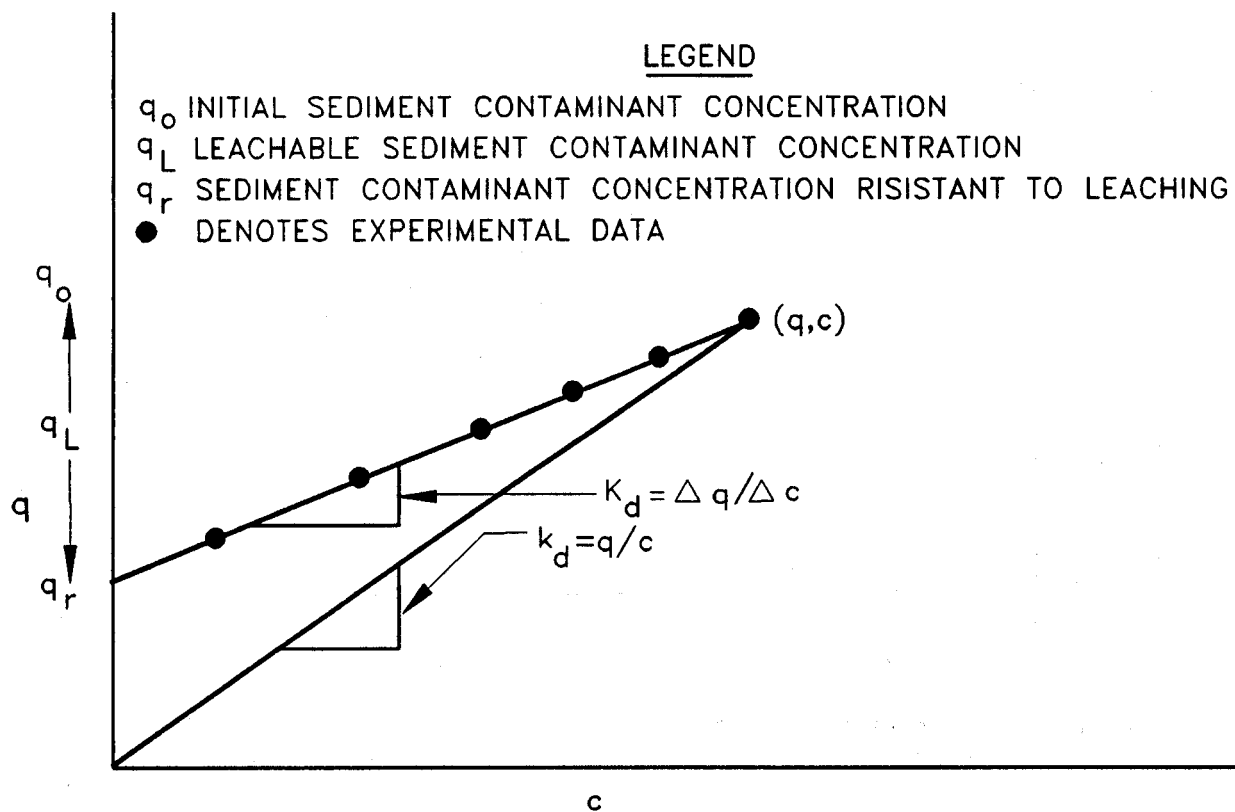

Figure 6. Classical linear desorption isotherms

PCB desorption isotherms for midrange concentration composite sediment, a turn toward classical linear desorption at the end of the sequential leach test.

58. Leachate metal concentrations for the hot-spot sediment were lower than those for midrange concentration composite sediment. For comparison, metal concentrations in the sequential leach tests for both types of sediment are shown in Figures 9-14. Leachate PCB concentrations for the hot-spot sediment were higher than those for midrange concentration composite sediment. The PCB congener C52, Aroclor 1242, and Aroclor 1254 concentrations in the sequential batch leach tests for both types of sediment are shown in Figures 15, 16, and 17, respectively.

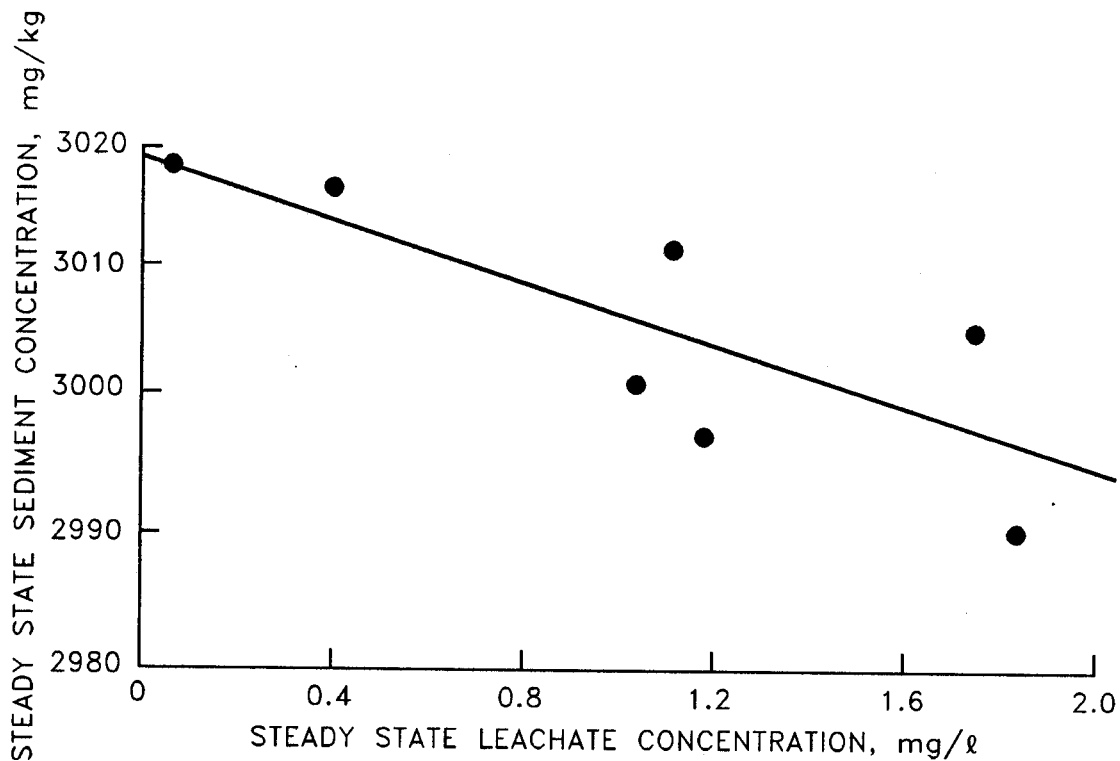

Figure 7. Desorption isotherm for zinc from anaerobic sequential batch testing of midrange concentration composite sediment

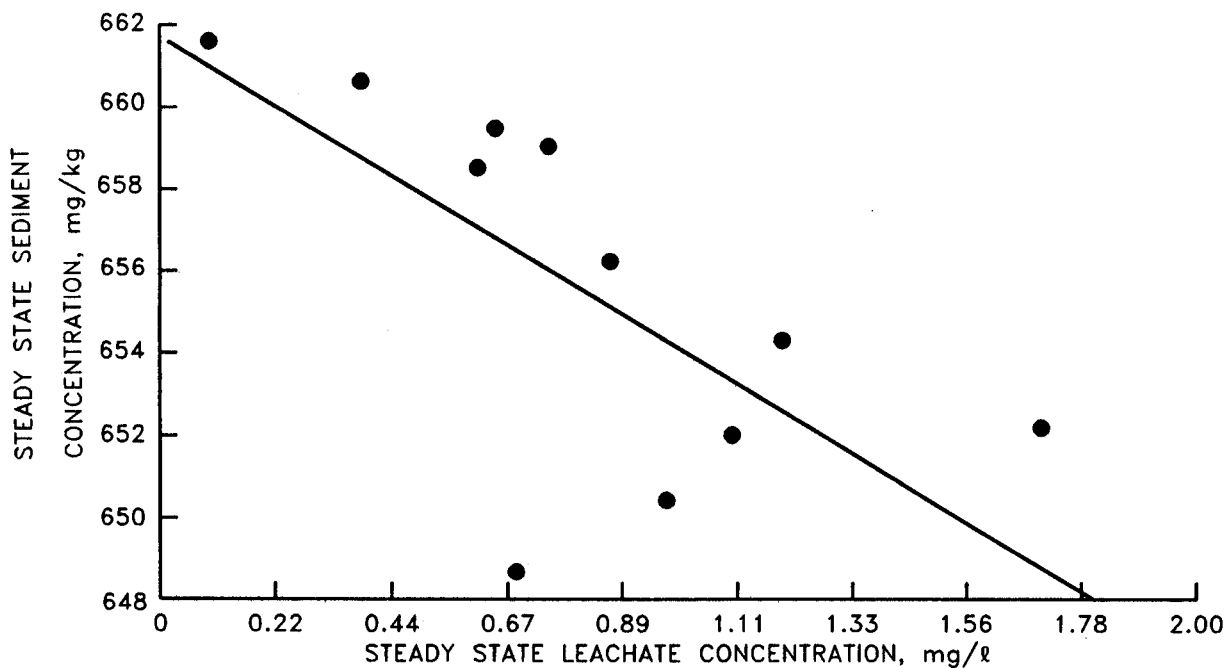

Figure 8. Desorption isotherm for Aroclor 1254 from anaerobic sequential batch testing of midrange concentration composite sediment

Table 6

Metal Desorption Isotherm Slopes from Sequential Batch Leach
Tests for Anaerobic New Bedford Harbor Sediments

<u>Metal</u>	<u>Midrange Composite*</u>		<u>Hot-Spot</u>	
	<u>r²**</u>	<u>Slope</u>	<u>r²</u>	<u>Slope</u>
Arsenic	0.002	0.450	NT†	--
Cadmium	0.393	-11.05	0.010	-0.658
Chromium	0.239	-7.35	0.433	-7.71
Copper	0.298	-6.37	0.461	-6.43
Lead	0.154	-5.09	0.152	5.49
Nickel	0.463	-13.72	0.109	-3.30
Zinc	0.513	-10.15	0.444	-7.55

* From Report 5.

** Correlation coefficient.

† Not tested.

Table 7
PCB Desorption Isotherm Slopes from Sequential Batch Leach
Tests for Anaerobic New Bedford Harbor Sediments

<u>Parameter</u>	<u>Mid-Range Composite*</u>		<u>Hot-Spot**</u>	
	<u>r²</u>	<u>Slope</u>	<u>r²</u>	<u>Slope</u>
C7†	0.535	-8.72	0.706	-8.13
C8	0.537	-7.97	0.766	-7.27
C28	0.671	-8.26	0.721	-6.59
C44	0.546	-7.87	0.766	-7.39
C49	0.181	-4.12	0.690	-7.02
C50	--	--	0.722	-6.52
C52	0.577	-7.72	0.729	-7.00
C70	0.555	-6.92	0.703	-6.99
C77	0.575	-8.06	--	--
C82	0.541	-7.29	--	--
C87	0.737	-7.27	0.632	-6.54
C97	0.673	-8.38	0.721	-6.92
C101	0.580	-7.60	0.656	-6.37
C105	0.450	-7.71	--	--
C118	0.486	-5.85	--	--
C136	0.579	-5.98	0.744	-6.43
C138	0.259	-5.94	0.614	-6.47
C143	--	--	0.991	-4.52
C153	0.495	-7.01	0.563	-5.61
C155	0.575	-7.35	0.710	-7.49
C167	0.948	-5.06	0.475	-5.47
C180	0.436	-5.41	0.516	-5.61
C185	--	--	--	--
Aroclor 1242	0.561	-7.15	0.719	-7.12
Aroclor 1254	0.552	-7.56	0.683	-6.62
Total PCB	--	--	0.696	-6.82

* From Report 5.

** From this study.

† See Table 5 for PCB congener identification key.

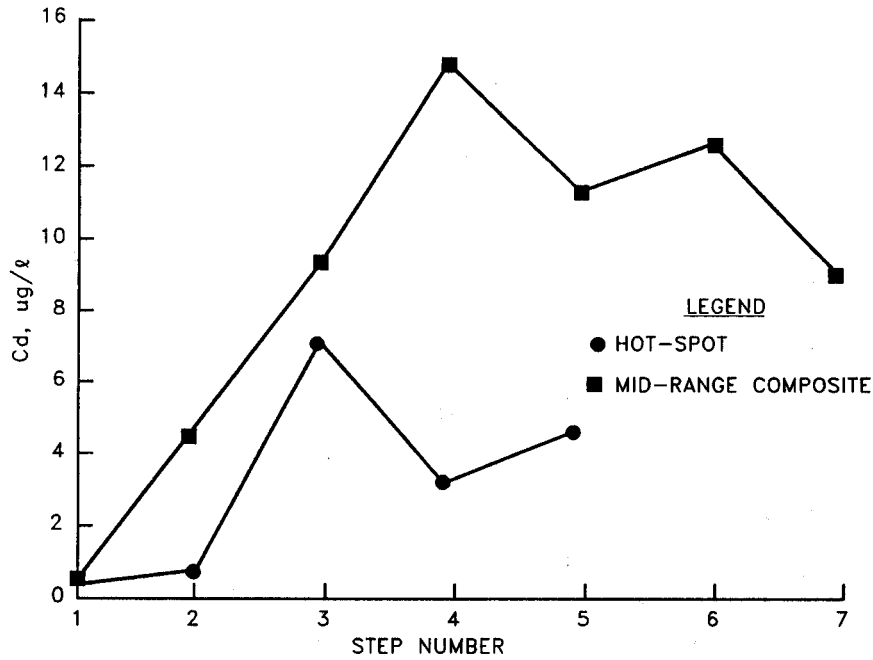

Figure 9. Mean cadmium concentrations in leachates from sequential batch leach tests for New Bedford Harbor sediments

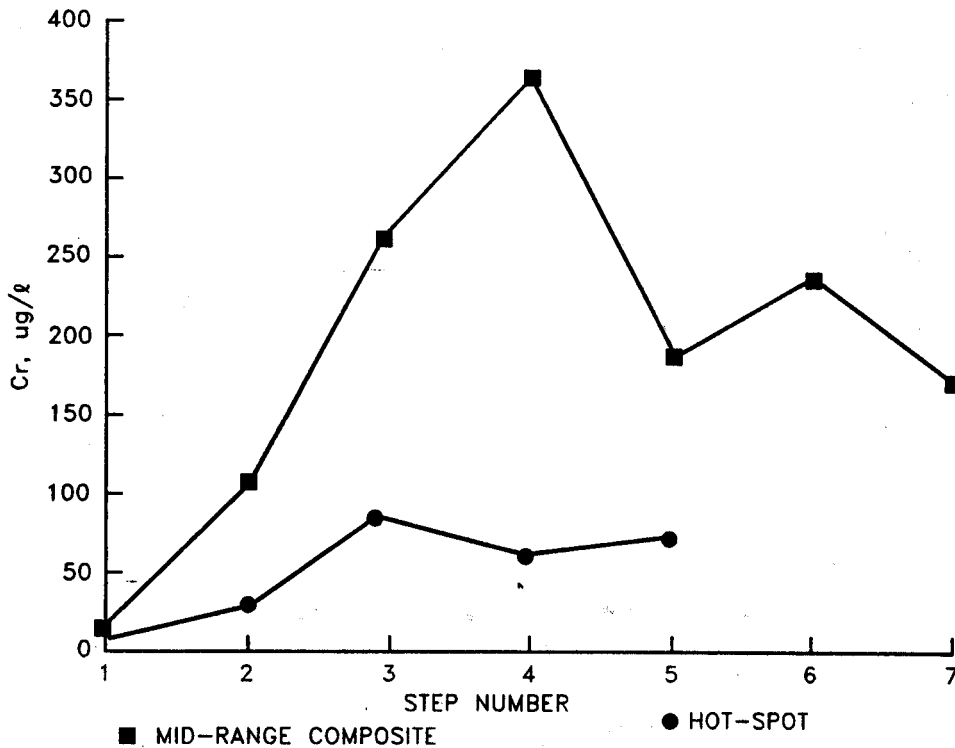

Figure 10. Mean chromium concentrations in leachates from sequential batch leach tests for New Bedford Harbor sediments

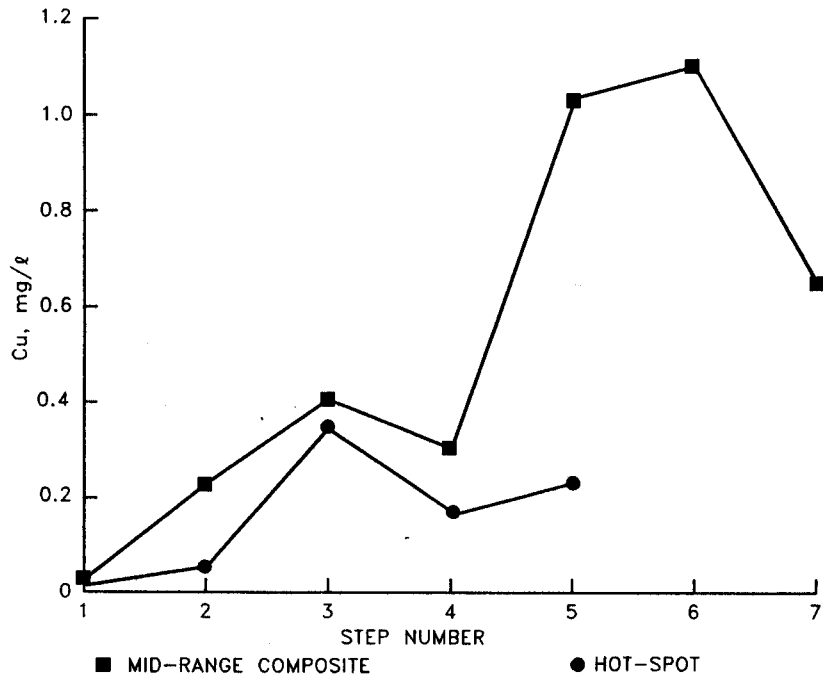

Figure 11. Mean copper concentrations in leachates from sequential batch leach tests for New Bedford Harbor sediments

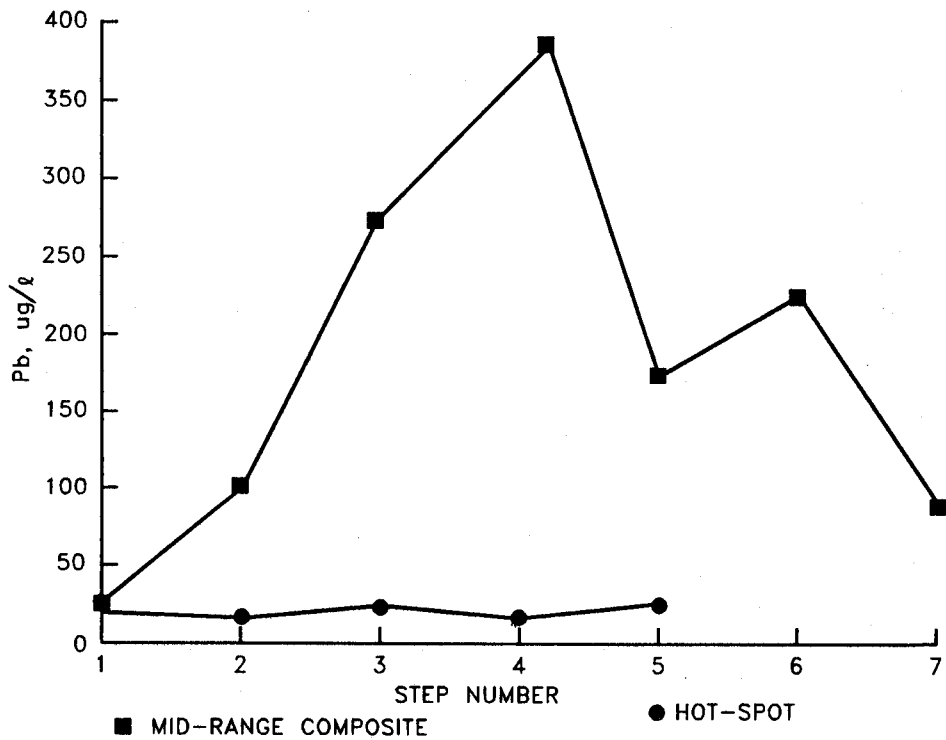

Figure 12. Mean lead concentrations in leachates from sequential batch leach tests for New Bedford Harbor sediments

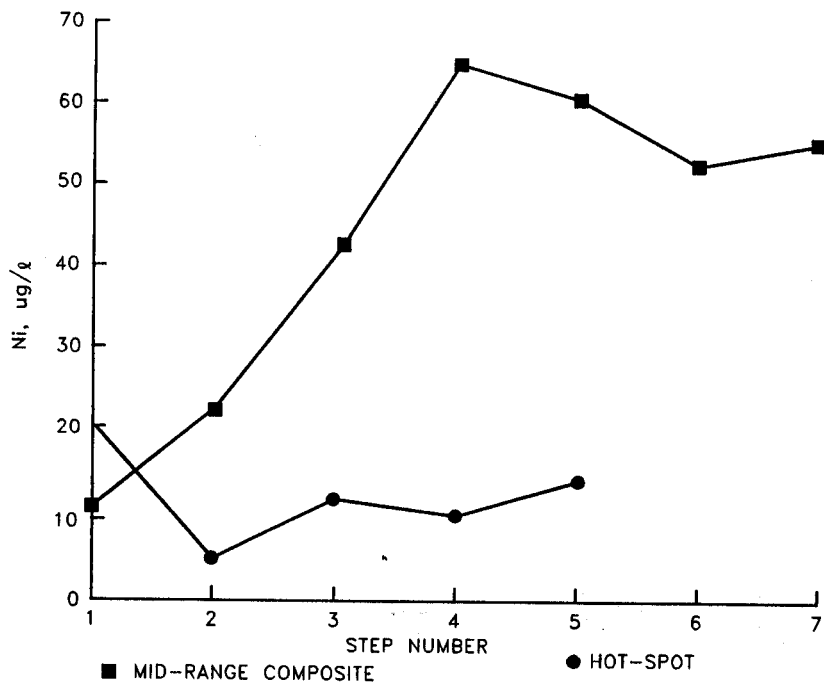

Figure 13. Mean nickel concentrations in leachates from sequential batch leach tests for New Bedford Harbor sediments

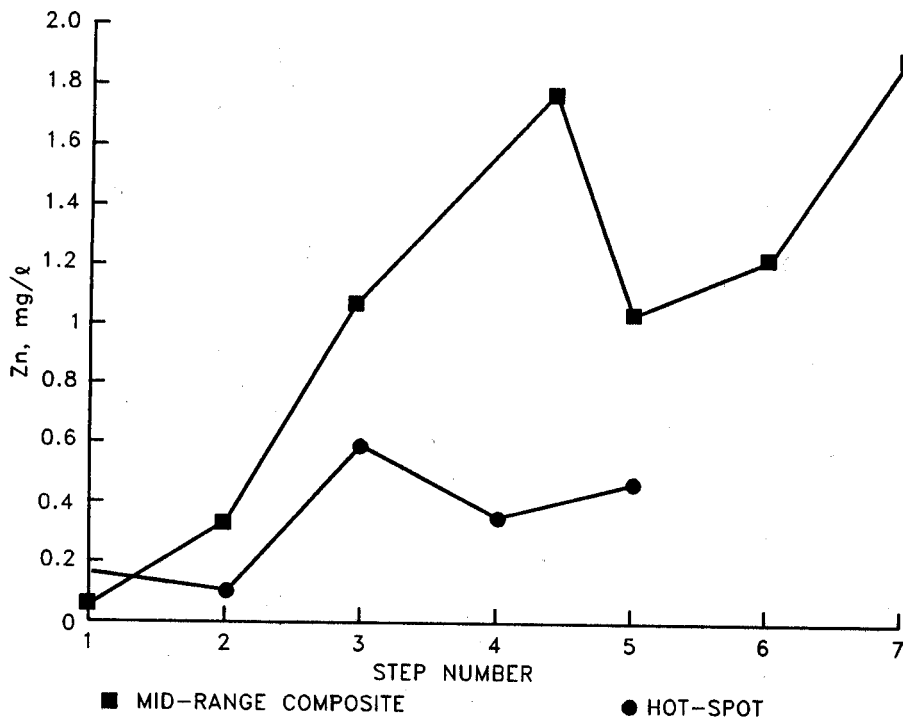

Figure 14. Mean zinc concentrations in leachates from sequential batch leach tests for New Bedford Harbor sediments

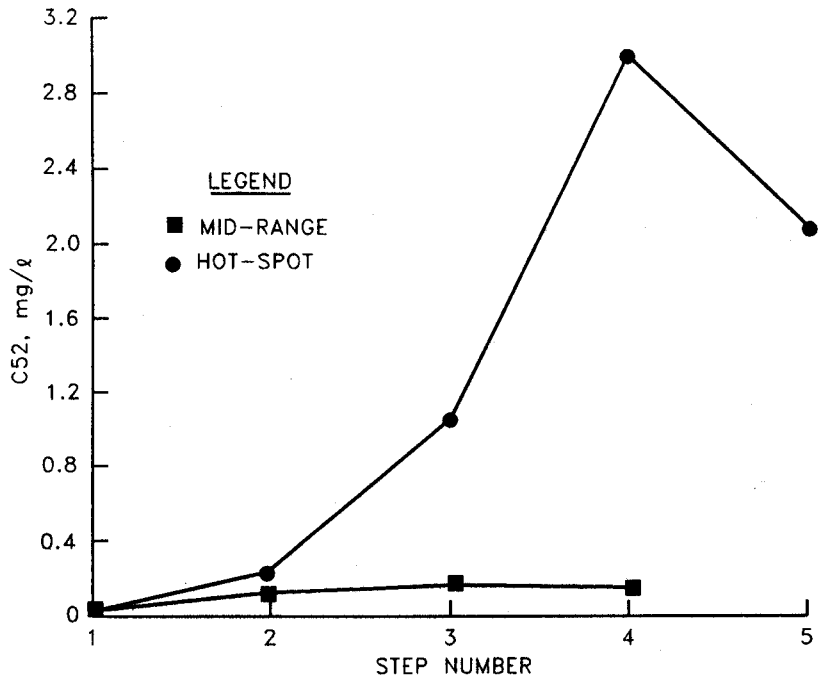

Figure 15. Mean PCB congener C52 concentrations in leachates from sequential batch leach tests for New Bedford Harbor sediments

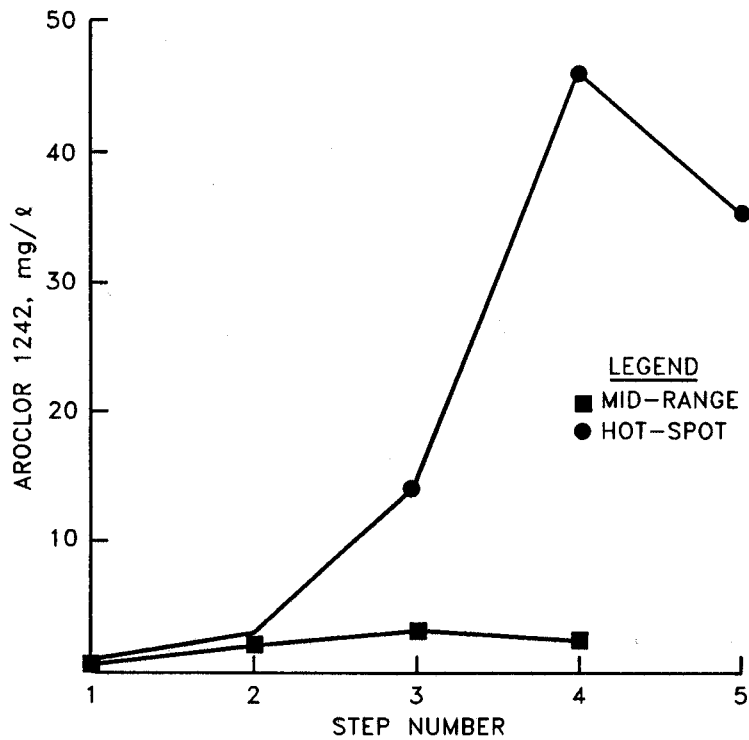

Figure 16. Mean Aroclor 1242 concentrations in leachates from sequential batch leach tests for New Bedford Harbor sediments

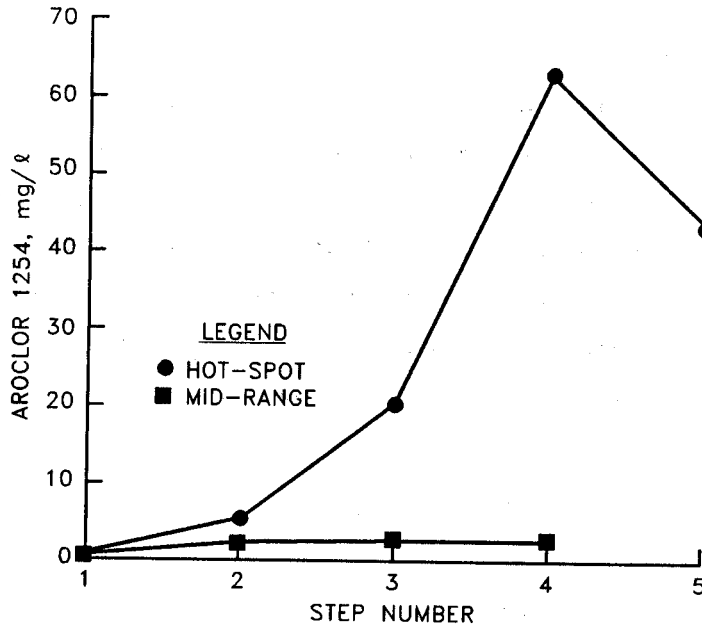

Figure 17. Mean Aroclor 1254 concentrations in leachates from sequential batch leach tests for New Bedford Harbor sediments

Batch Leach Tests for Solidified/Stabilized Sediment

59. The presentation and discussion of batch leach data is arranged as follows. Calculations of total contaminant mass leached during sequential batch leach testing are presented first. These data are normalized for additive dosage. Then, a more involved examination and interpretation of the data is presented using desorption isotherm analysis. The batch leach data and desorption isotherms for solidified/stabilized New Bedford Harbor sediments are presented in Appendix B.

Total contaminant mass leached

60. The total mass leached in the sequential batch leach test for each contaminant was calculated as follows:

$$M = \sum C_i V \quad \text{for } i = 1 \text{ to } n \quad (1)$$

where

M = total mass of contaminant leached, mg

C_i = concentration in leachate from ith step, mg/l

i = step index

n = number of steps in sequential leach test

V = volume of leachate at the end of each step, l

The mass leached data were normalized with respect to the amount of additive used to solidify/stabilize the sediment. By normalizing the data, the contaminant mass leached from solidified/stabilized sediment could be compared with the contaminant mass leached from untreated sediment, and comparisons between processes with different additive dosages could also be made. The data were normalized using the following equation:

$$NM = \frac{(M)(1 + R + Rw)}{M_{s/s}} \quad (2)$$

where

NM = normalized mass leached concentration, mg/kg

R = dosage of S/S reagents, kg reagent/kg wet sediment solids

w = water content of the wet sediment, kg water/kg sediment solids

$M_{s/s}$ = mass of solidified material (dry weight) leached, kg

The water contents for midrange concentration composite sediment and hot-spot sediment were 1.87 and 2.04 kg water/kg sediment solids. Equation 2 does not include a correction for the mass of dry solids produced by hydration of setting agent(s). This mass is assumed to be negligible.

61. Normalized mass leached concentrations of metals from four-step sequential leach tests for solidified/stabilized midrange concentration composite and hot-spot sediments are presented in Tables 8 and 9, respectively. Also listed in Tables 8 and 9 is the total mass of each metal leached in the sequential leach test for the untreated sediment.

62. Cadmium and zinc. The amounts of cadmium and zinc leached from solidified/stabilized sediment were lower than the amount leached from the untreated midrange concentration composite and hot-spot sediments. Thus, solidification/stabilization processing reduced the leachability of cadmium and zinc relative to the leachability of these metals in the untreated sediments. The portland cement with Firmix formulations leached less cadmium and zinc than the portland cement formulations and the STC process. Thus, the portland cement with Firmix process provided better chemical stabilization of cadmium and zinc than either the portland cement process or the STC process.

Table 8

Metals Leached in Sequential Batch Leach Tests for Solidified/Stabilized
Midrange Concentration Composite Sediment from New Bedford Harbor

Process*	Number of Steps	Normalized Mass Leached, mg/kg**					
		Cadmium	Chromium	Copper	Lead	Nickel	Zinc
Untreated	2		0.46				
	4	0.11	2.95	11.7	3.15	0.57	13.1
	5	0.15	3.64	15.7	3.84	0.84	17.2
0.1 PC:1.0 Sed	2				0.47†		
	4	0.009	1.65	121	--	9.38	0.47
0.2 PC:1.0 Sed	2				1.66†		
	4	0.004	1.50	75	--	7.22	0.84
0.3 PC:1.0 Sed	2				2.92†		
	4	0.003	1.00	69	--	7.95	1.27
0.2 PC:0.1 F:1.0 Sed	4	<0.001	2.12	88	0.35	5.48	<0.38
0.15 PC:0.15 F:1.0 Sed	4	<0.001	2.14	76	0.63	4.76	<0.38
0.1 PC:0.2 F:1.0 Sed	4	<0.001	1.73	71	1.34	5.11	<0.38
0.3 STC:1.0 Sed	4	0.006	1.01	48	0.06	6.12	††
	5	0.007	1.50	55	0.07	6.38	

* See Table 1 for description of processes.

** Mean of four replicates for untreated sediment and mean of three replicates for solidified/stabilized sediment, calculated using Equations 1 and 2.

† Two-step sequential batch leach test due to contamination in blanks in steps three and four. See Appendix B for details.

†† Data rejected due to contamination in blanks.

Table 9

Metals Leached in Sequential Batch Leach Tests for Solidified/Stabilized
Hot-Spot Sediment from New Bedford Harbor*

Process	Normalized Mass Leached, mg/kg**				
	Cadmium	Chromium	Copper	Lead	Nickel
Untreated	0.057	0.95	3.18	0.18	0.26
0.3 PC:1.0 Sed	0.004	0.27	87	4.80	10.7
0.3 STC:1.0 Sed	0.007	1.53	50	0.07	4.8

* Five-step sequential batch leach test.

** Mean of four replicates for untreated sediment and mean of three replicates for solidified/stabilized sediment, calculated using Equations 1 and 2.

There was no difference between the various portland cement with Firmix formulations for chemical stabilization of cadmium or zinc. There was, however, a difference in chemical stabilization properties of the various portland cement process formulations for cadmium. The higher the portland cement dosage, the less cadmium leached. For zinc, however, the mass leached tended to increase as the portland cement dosage increased.

63. Chromium. The amount of chromium leached from solidified/stabilized midrange concentration composite sediment was lower than the amount leached from the untreated sediment. Thus, S/S processing using portland cement, portland cement with Firmix, and the STC additive partially stabilized chromium against aqueous leaching. The amount of chromium leached from the portland cement and portland cement with Firmix processed sediment decreased with increasing amounts of portland cement. The portland cement process also reduced the amount of leachable chromium in the hot-spot sediment. The STC process, however, did not appear to chemically stabilize chromium in the hot-spot sediment.

64. Lead. The portland cement process leached more lead, and the portland cement with Firmix and STC processes leached less lead than the untreated sediments. Thus, the portland cement with Firmix and STC processes chemically

stabilized lead relative to the amount leached from untreated sediment. The portland cement process mobilized lead. The amount of lead leached for both processes increased with increasing portland cement dosage. The STC process was the most effective process for chemical stabilization of lead in both types of sediment.

65. Copper and nickel. The amount of copper and nickel leached from the processed sediment was significantly higher than the amount leached from the untreated sediments. The mass of copper leached from the solidified/stabilized sediment ranged from 3 to 27 times the amount leached from untreated sediment, and the mass of nickel leached from the solidified/stabilized sediment ranged from 7 to 41 times the amount leached from the untreated sediments. For the midrange concentration composite sediment, copper mobilization decreased with increasing dosages of portland cement. Substitution of Firmix for portland cement did not reduce the amount of copper leached from solidified/stabilized midrange concentration composite sediment, but the amount of nickel leached was reduced by Firmix substitution. The STC process also mobilized copper and nickel, but to a lesser degree than the portland cement and portland cement with Firmix processes.

66. Several explanations for mobilization of copper and nickel by S/S processing are possible. Many toxic metals are amphoteric (show increased solubility at both high and low pH) (Cullinane, Jones, and Malone 1986). Theoretical solubilities of selected amphoteric metal hydroxides are shown in Figure 18. The pH-solubility chart shown in Figure 18 indicates order-of-magnitude differences in metal hydroxide solubilities over a narrow pH range. The chart also indicates that copper and nickel hydroxide solubilities are the most sensitive of the metals shown to pH changes. Thus, a shift in pH by the additives could selectively increase metal solubilities. This explanation, however, is difficult to reconcile with the pH data collected during the leach tests. Comparison of leachate pH values (Table 10) from the sequential batch leach tests conducted on solidified/stabilized midrange concentration composite sediment and untreated sediment shows that leachate pH for treated sediment was in the range of minimum theoretical solubility for metal hydroxides, whereas the leachate pH for untreated sediment was in the range of metal hydroxide solubilities that are two orders of magnitude higher than the theoretical minimum. Similar values were obtained for the hot-spot sediment (Appendix B). For the amphoteric property explanation to be correct, the

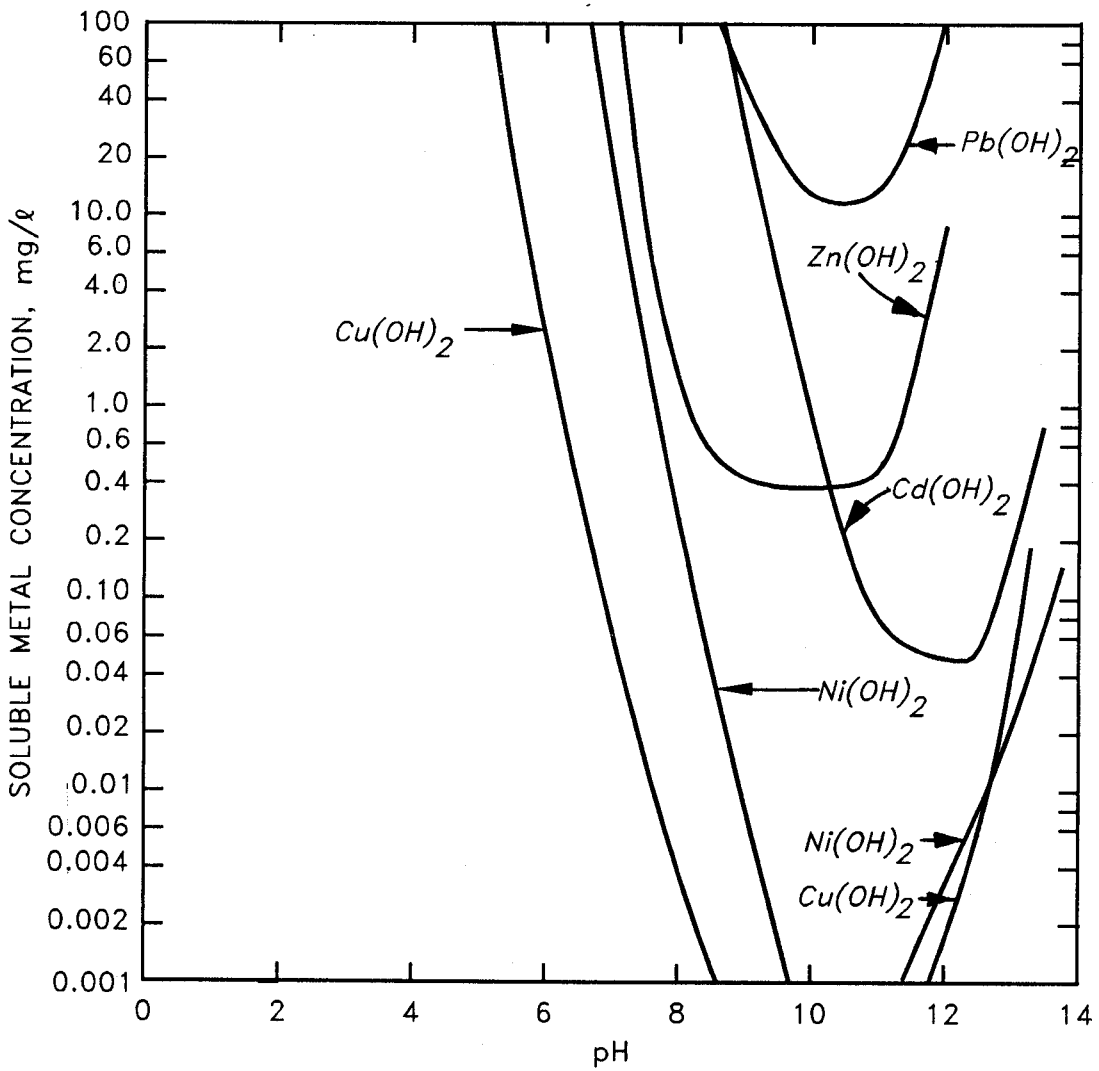

Figure 18. Theoretical pH-solubility chart for metal hydroxides (from Cullinane, Malone, and Jones 1986)

Table 10
Metals Sequential Leach Composite pH Values

<u>Solidified/Stabilized Sediment</u>	<u>Step Number</u>				
	<u>1</u>	<u>2</u>	<u>3</u>	<u>4</u>	<u>5</u>
Midrange concentration composite	7.2	7.3	7.1	7.6	--
0.1 PC	11.6	11.7	11.6	11.8	--
0.2 PC	12.4	12.3	11.9	12.1	--
0.3 PC	12.5	12.4	12.5	12.5	--
0.2 PC:0.1 F	11.8	11.9	11.8	11.8	--
0.15 PC:0.15 F	12.1	12.0	12.0	11.9	--
0.1 PC:0.2 F	12.3	12.2	12.1	12.0	--
0.3 STC	10.6	10.5	9.6	9.2	10.3
Hot-spot					
0.3 PC	12.1	12.0	12.0	12.0	12.0
0.3 STC	9.5	10.4	9.9	10.6	10.4

dependency of metal solubilities in solidified/stabilized sediment on pH must be different from the theoretical for metal hydroxides. In a complex system such as solidified/stabilized sediment, it is likely that metal solubilities differ from the theoretical, but the data available are not sufficient to determine if the apparent mobilization of copper and nickel was caused by an alteration of metal solubility.

67. Normalization of the data could have introduced an "apparent" mobilization effect if the solidification reagents were a source of leachable copper and nickel or the sediment sample processed by S/S had significantly higher concentrations of copper and nickel than the sample used in the untreated sediment leach tests. Bulk analysis of the solidification reagents for metals is presented in Table 11. Bulk chemical analysis showed the order of metal contamination in the additives to be as follows: proprietary silicate additive > portland cement > Firmix. Bulk metal concentrations in the proprietary silicate additive were approximately one order of magnitude lower than in the sediments (Table 3). Bulk metal concentrations in the Firmix

Table 11
Bulk Metal Concentrations in Solidification Reagents*,**

<u>Reagent</u>	<u>Cadmium</u>	<u>Chromium</u>	<u>Copper</u>	<u>Lead</u>	<u>Nickel</u>	<u>Zinc</u>
Portland Cement	0.11 (0.01)	48.0 (0.9)	20.6 (0.4)	41.6 (0.6)	26.2 (0.3)	426 (3)
Firmix	0.06 (0.01)	20.1 (0.3)	1.03 (0.06)	0.12 (0.04)	1.33 (0.09)	<3.00 --
STC	3.24	112	172	132	24.0	556

* Expressed in milligrams per kilogram dry weight (standard error in parentheses).

** Triplicate analysis for portland cement and Firmix, single analysis for proprietary silicate additive.

additive were insignificant compared with the sediment bulk metal concentrations. The concentrations of copper and nickel in the Firmix additive, if completely leached, account for less than 1 percent of the copper and less than 10 percent of the nickel leached from the portland cement with Firmix products. The bulk copper concentration in the portland cement, if completely leached, accounts for less than 15 percent of the copper leached from the portland cement and portland cement with Firmix products. Thus, the bulk copper concentrations in the portland cement and the Firmix additive were not sufficient to account for the leachable concentrations of copper in the solidified/stabilized sediments. The bulk concentration of copper in the STC additive was much higher than the bulk copper concentration in the portland cement and the Firmix additive and, if completely leached, could account for 100 percent of the copper leached from the STC product. The STC solidified/stabilized sediment leached less copper than the portland cement and portland cement with Firmix products, however. The bulk nickel concentrations in the portland cement and the STC additive were about the same and, if completely leached, could account for 100 percent of the nickel leached from the solidified/stabilized sediment processed with these additives.

68. It is difficult to accept an explanation based on contaminated solidification reagents because, in general, the bulk metal concentration is not completely leachable and, for some additives, the bulk copper concentrations were not sufficient to account for more than about 20 percent of the copper leached from the solidified/stabilized sediments. The remaining leachable copper must have been supplied by the sediment. In addition, the leachable concentrations of copper and nickel in the solidified/stabilized sediments do not vary over a wide range although the bulk copper and nickel concentrations in the additives vary by one to two orders of magnitude. The absence of an appropriate response in leachable metals in solidified/stabilized sediments to bulk metal concentrations in the additives does not support an explanation based on additives as the source of leachable copper and nickel in the solidified/stabilized products. The metals in the additives may leach to an extent, but the bulk metal data on additives do not explain the apparent mobilization of copper and nickel.

69. Differences between the sediment used in the untreated sediment leach tests and the sediment used in the S/S processing tests should be small. Both tests used material from one barrel that was well mixed before samples for testing were taken. It is not likely, therefore, that the copper and nickel concentrations in the materials tested differed by an order of magnitude, as would be necessary to explain the mobilization effect shown in Tables 8 and 9.

70. The apparent copper and nickel mobilization may also be explained as differences in leaching characteristics. In the untreated sediment leach tests, copper and nickel concentrations increased with each step in the sequential leach test (see Report 5), but in the solidified/stabilized sediment leach tests, copper and nickel concentrations decreased with each step in the sequential leach procedure. Thus, the leachable copper and nickel may be nearly the same, but in untreated sediment more steps are required to remove all the leachable copper and nickel than are required for solidified/stabilized sediment.

71. On the basis of the above discussion, it is likely that the last explanation, alone or in combination with the others, accounts for the mobilization effect. Additional discussion of the differences in leaching characteristics is provided in this report in the section on desorption isotherm analysis.

72. PCBs. Normalized mass leached concentrations for total PCB, PCB Aroclors, and PCB congeners in midrange concentration composite sediment solidified/stabilized with portland cement, portland cement with Firmix, and proprietary silicate processes are presented in Table 12. The mass leached data presented are for a single-step batch leach test. The S/S data were normalized using Equations 1 and 2. The PCB data from the first step of the sequential batch leach tests conducted on untreated midrange concentration composite sediment (Report 5) are also presented in Table 12.

73. The data in Table 12 show reduction in PCB leached, compared with the PCB leached from the untreated sediment, after S/S using portland cement and portland cement with Firmix. Percent reduction for the three portland cement formulations ranged from 73 to 90 percent, and percent reduction for the three portland cement with Firmix formulations ranged from 72 to 92 percent. The portland cement and portland cement with Firmix processes were approximately equally effective in reducing the amount of PCB leached. For the portland cement process, the percent reduction decreased as the portland cement dosage increased. No distinct trends in reduced leachability with additive dosage were evident in the portland cement with Firmix data.

74. Data on the PCB leached in the first step of a five-step sequential batch leach test of STC processed midrange concentration composite sediment are presented in Table 12 for comparison with the data for the portland cement and portland cement with Firmix data. The mass of PCB leached in the first leach step for STC processed sediment was very close to the mass of PCB leached from the portland cement and portland cement with Firmix processed sediment. Results from sequential batch leach tests for portland cement and STC processed sediment are discussed below.

75. The theoretical basis for using a single-step batch leach test, as previously discussed, assumes that the distribution coefficient is constant and that all of the contaminant is leachable. The sequential batch leach tests conducted on untreated midrange concentration composite (Report 5) and hot-spot (Appendix A) sediments showed nonconstant partitioning and PCB concentrations in the aqueous phase that increased with successive steps in the leach tests. Because sequential batch leach data for untreated New Bedford Harbor sediment were not available when leach testing of the solidified/stabilized sediment was initiated, the potential limitations of a single-step

Table 12

PCB Leached in Single-Step Batch Leach Tests for Solidified/Stabilized
Midrange Concentration Composite Sediment

Contaminant	Untreated Midrange Sediment*	Normalized Mass Leached, mg/kg, by Process						0.3 STC Pro- cessed Midrange
		0.1 PC	0.2 PC	0.3 PC	0.1 F/ 0.2 PC	0.15 F/ 0.15 PC	0.2 F/ 0.1 PC	
Aroclor 1016	<0.0008	<0.0010	<0.0013	<0.0015	<0.0015	<0.0015	<0.0015	<0.0015
Aroclor 1221	<0.0008	<0.0010	<0.0013	<0.0015	<0.0015	<0.0015	<0.0015	<0.0015
Aroclor 1232	<0.0008	<0.0010	<0.0013	<0.0015	<0.0015	<0.0015	<0.0015	<0.0015
Aroclor 1242	1.0120	0.0385	0.0598	0.1893	0.0584	0.1923	0.0528	0.1168
Aroclor 1248	<0.0008	<0.0010	<0.0013	<0.0015	<0.0015	<0.0015	<0.0015	<0.0015
Aroclor 1254	0.74800	0.0242	0.0641	0.0202	0.0080	0.0194	0.0053	0.0075
Aroclor 1260	<0.0008	<0.0010	<0.0013	<0.0015	<0.0015	<0.0015	<0.0015	<0.0015
Total PCBs	ND**	0.0559	0.0781	0.3024	0.0950	0.2868	0.0738	0.1393
C7	0.00020	0.00009	0.00011	0.00020	0.00018	0.00020	0.00016	0.00003
C8	0.10840	0.02924	0.03427	0.05983	0.04733	0.06057	0.04298	0.00472
C28	0.13600	0.00920	0.00995	0.01784	0.01658	0.01779	0.01853	0.00675
C44	0.05240	0.00224	0.00144	0.00333	0.00327	0.00370	0.00402	0.00037
C49	0.07760	0.00046	0.00039	0.00187	0.00092	0.00163	0.00104	0.00035
C50	0.00004	0.00920	0.00995	0.01305	0.01449	0.01779	0.01293	0.00472
C52	0.05040	0.00403	0.00375	0.00744	0.00629	0.00737	0.00673	0.00165
C70	0.01480	0.00077	0.00048	0.00115	0.00140	0.00248	0.00143	0.00020
C77	0.16920	0.00161	0.00067	0.00946	0.00312	0.00945	0.00344	0.00029
C82	0.00240	0.00059	<0.00006	0.00038	0.00023	0.00026	0.00027	0.00018
C87	0.00080	0.00024	<0.00006	<0.00007	0.00028	0.00032	0.00022	<0.00007
C97	0.01200	0.00056	0.00025	0.00044	0.00151	0.00114	0.00062	0.00013
C101	0.02760	0.00078	0.00037	0.00125	0.00172	0.00117	0.00251	0.00017
C105	0.02280	0.00055	<0.00006	<0.00007	0.00014	0.00022	0.00062	<0.00007
C118	0.00320	0.00053	0.00006	0.00028	0.00090	0.00049	0.00081	0.00007
C136	0.00160	0.00078	0.00006	0.00017	0.00014	0.00025	0.00083	<0.00007
C138	0.04800	0.00068	0.00012	0.00059	0.00050	0.00102	0.00064	0.00003
C143	<0.00004	<0.00005	<0.00006	0.00026	0.00007	<0.00007	0.00061	<0.00007
C153	0.10080	<0.00005	<0.00006	0.00051	0.00074	0.00063	0.00118	<0.00007
C155	0.02080	0.00058	<0.00006	0.00111	0.00172	0.00304	0.00033	0.00013
C167	0.00040	<0.00005	<0.00006	0.00009	0.00024	<0.00007	0.00059	0.00008
C180	0.00040	0.00012	<0.00006	<0.00007	0.00008	<0.00007	0.00040	<0.00007
C185	0.00004	<0.00005	<0.00006	0.00058	<0.00007	0.00014	0.00004	<0.00007

* From Report 5.

** No data.

procedure for estimating PCB leachability from untreated and solidified/stabilized New Bedford Harbor sediment were not known. This information was available, however, before the leach tests on the STC process and the hot-spot sediment were initiated. Therefore, a sequential batch leach procedure was selected for evaluating chemical stabilization of PCBs by the proprietary silicate process for midrange concentration composite sediment and hot-spot sediment. A sequential batch leach procedure was also used to leach hot-spot sediment that had been solidified/stabilized using portland cement.

76. The sequential batch leach data for portland cement and STC processed sediments are presented in Appendix B. Normalized mass leached concentrations for total PCB, PCB Aroclors, and PCB congeners are presented in Table 13. The S/S data in Table 13 were normalized using Equations 1 and 2.

77. The data in Table 13 show that S/S processing using portland cement and the STC additive reduced the amounts of total PCB, PCB Aroclors, and most PCB congeners leached from New Bedford Harbor sediments by factors of 10 to 100 as compared with the untreated sediment. This is a significant finding in light of what is known about chemical stabilization of organic compounds by S/S technology. Few studies have been published on the performance of solidified/stabilized mixtures containing organic wastes, and reduction in PCB leachability by S/S processing has not been previously reported. The consensus has been that chemical stabilization of organics against aqueous leaching by S/S technology has not been established (Tittlebaum et al. 1985). For these reasons, reduction in PCB leachability of one to two orders of magnitude is a major finding.

78. The reduction in Aroclor 1242 concentrations in sequential batch leach tests for untreated and solidified/stabilized hot-spot sediment is shown in Figure 19. The contrast between untreated and solidified/stabilized sediment shown in Figure 19 is representative of the entire data set for PCBs. Caution must be exercised in directly comparing leachate concentrations because setting agents used in S/S processing dilute the sediment PCB concentration. It is also possible that PCBs were volatilized during the mixing, curing, crushing, and sieve analysis required to prepare solidified/stabilized specimens for leach testing. Analysis of solidified/stabilized samples prior to leach testing gave results within 50 to 80 percent of the expected value after accounting for dilution by setting agents (Appendix B) and showed that the PCB concentrations in the solidified/stabilized sediments were

Table 13

PCB Leached in Sequential Leach Tests of Solidified/Stabilized
Midrange and Hot-Spot Sediments

Contaminant	Normalized Mass Leached, mg/kg				
	Untreated Midrange Sediment*	Untreated Hot-Spot Sediment**	STC Processed Midrange*	STC Processed Hot-Spot**	0.3 PC Processed Hot-Spot**
Aroclor 1016	0.0032	0.0040	0.0033	0.0047	0.0047
Aroclor 1221	0.0032	0.0040	0.0033	0.0047	0.0047
Aroclor 1232	0.0032	0.0040	0.0033	0.0047	0.0047
Aroclor 1242	21.0	384.1	0.4316	1.9375	2.6547
Aroclor 1248	0.0032	0.0040	0.0033	0.0047	0.0047
Aroclor 1254	12.0	110.0	0.0313	0.1003	0.1054
Aroclor 1260	0.0032	0.0040	0.0033	0.0047	0.0047
Total PCBs	ND†	507.732	0.4927	2.2516	2.8622
C7	0.002	0.068	0.00017	0.00107	0.00182
C8	1.454	42.920	0.03885	0.36890	0.67740
C28	1.629	55.992	0.02935	0.16079	0.20110
C44	0.655	14.980	0.00439	0.03586	0.03976
C49	0.273	3.260	0.00138	0.00622	0.00672
C50	0.00016	43.604	0.02015	0.14183	0.15340
C52	1.057	24.420	0.00899	0.04950	0.16660
C70	0.398	14.050	0.00221	0.01825	0.01951
C77	2.489	0.00020	0.00263	0.01084	0.01720
C82	0.051	0.00020	0.00030	0.00071	0.00054
C87	0.069	1.084	0.00050	0.00551	0.00075
C97	0.248	7.112	0.00095	0.01291	0.00544
C101	0.578	16.548	0.00231	0.01872	0.01067
C105	0.203	0.00020	0.00026	0.00058	0.00050
C118	0.102	0.00020	0.00082	0.00334	0.00310
C136	0.166	3.012	0.00111	0.00087	0.00841
C138	0.237	2.732	0.00041	0.00223	0.00840
C143	0.00016	0.676	0.00011	0.00032	0.02046
C153	0.934	24.420	0.00079	0.00394	0.00473
C155	0.479	8.656	0.00107	0.00572	0.00715
C167	0.080	0.616	0.00016	0.00295	0.01209
C180	0.058	0.744	0.00017	0.00032	0.00074
C185	0.001	0.061	0.00015	0.00023	0.00023

* Calculated using five-step sequential leach test.

** Calculated using four-step sequential leach test.

† No data.

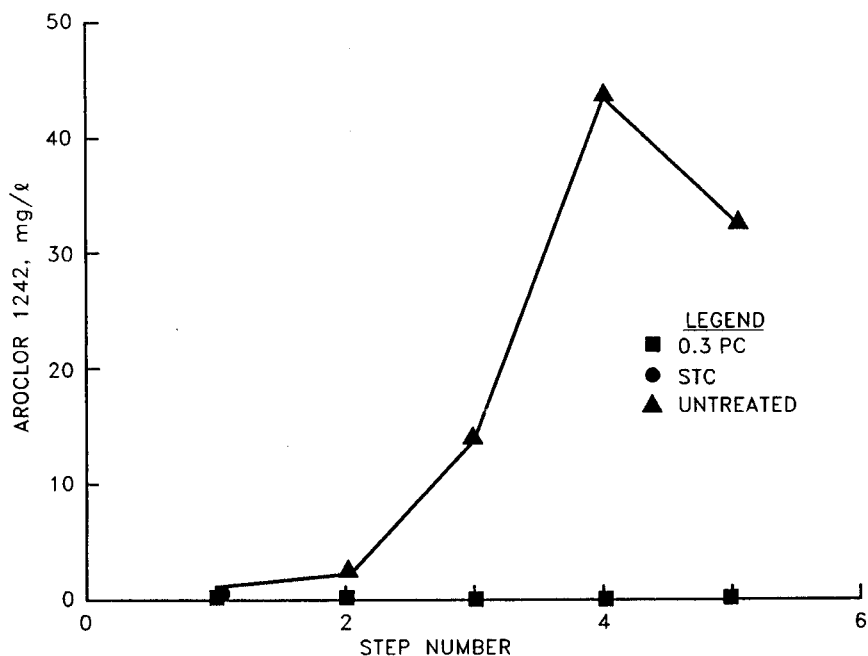

Figure 19. Aroclor 1242 leachate concentrations in sequential batch leach tests for untreated and solidified/stabilized hot-spot sediment

approximately one half the PCB concentration in the untreated sediments. Dilution by setting agents and losses during S/S processing and sample preparation cannot, therefore, account for the order-of-magnitude differences in leachate concentrations. It is also possible that S/S processing dechlorinates or otherwise alters PCB molecules such that they are not identifiable as PCB. The basis of such an explanation is essentially speculation. If the speculative possibility of unknown reaction(s) that alter PCB is disregarded, the data indicate that S/S processing reduced the leachability of PCBs.

79. The STC process did not significantly improve chemical stabilization of PCBs in New Bedford Harbor sediment over that available using a generic portland cement process (Table 13). Figure 20 shows Aroclor 1242 concentrations in sequential batch leach tests for solidified/stabilized sediments processed using portland cement and the STC additive. The differences are minor. For both processes, the additive dosage was 0.3 additive to 1.0 wet sediment by weight, and the PCB concentrations in the solidified/stabilized products were approximately the same (Appendix B).

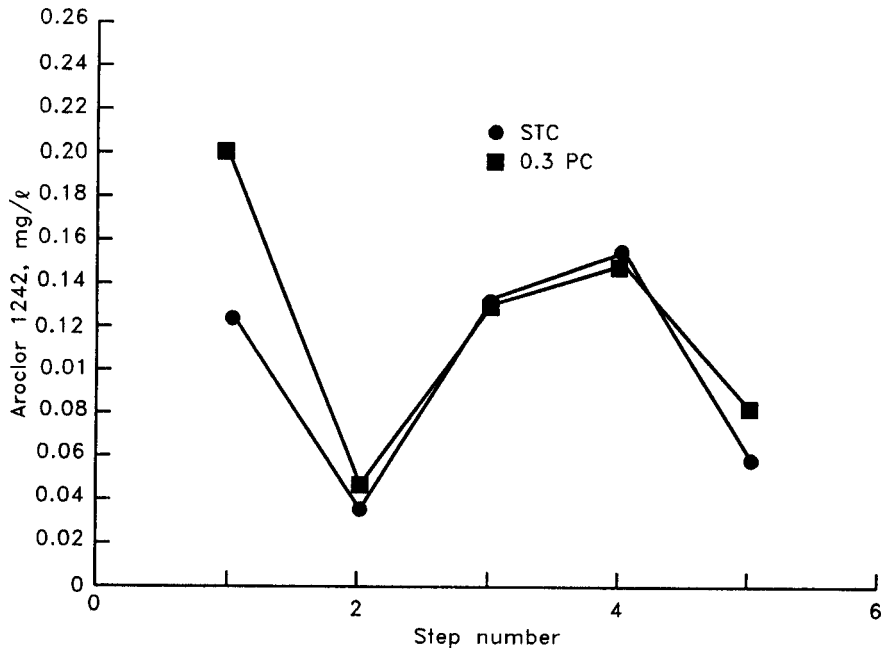

Figure 20. Aroclor 1242 leachate concentrations in sequential batch leach tests for hot-spot sediment processed using portland cement and Silicate Technology Corporation proprietary additive

Desorption isotherm analysis

80. Results from the sequential batch leach tests conducted on New Bedford Harbor solidified/stabilized sediments were evaluated using desorption isotherm analysis. Desorption isotherm analysis is a data reduction technique for extrapolating contaminant release beyond the last step in the sequential leach test and estimating the total mass that would leach if an infinite number of leaching steps were used. The technique is limited to classical sorption isotherm forms.

81. Desorption isotherms are plots of solid phase contaminant concentration (q) versus aqueous phase contaminant concentration (C). The sequential batch leach data were reduced to tables of solid and aqueous phase contaminant concentrations using the equations described below. The solid phase concentration after each leach step is given by

$$\begin{array}{l} \text{Solidified sediment} \\ \text{contaminant} \\ \text{concentration} \\ \text{after} \\ \text{leaching} \end{array} = \begin{array}{l} \text{Solidified sediment} \\ \text{contaminant} \\ \text{concentration} \\ \text{before} \\ \text{leaching} \end{array} - \frac{\text{Mass of contaminant} \\ \text{leached}}{\text{Mass of solidified} \\ \text{sediment}}$$

or

$$q_i = q_{i-1} - \frac{C_i V}{M_{s/s}} \quad \text{for } i = 1 \text{ to } n \quad (3)$$

where

q_i = solid phase contaminant concentration after the i^{th} leach step, mg/kg

C_i = aqueous phase contaminant concentration at the end of the i^{th} leach step, mg/l

$M_{s/s}$ = mass of solidified material, kg

n = number of steps in leaching test

To use Equation 3, a value for the initial contaminant concentration in the solidified/stabilized sediment (q_0) is needed to calculate the solid phase contaminant concentration after the first step ($i = 1$). Bulk analyses of solidified/stabilized sediment samples for metal and PCB concentrations prior to leaching are presented in Appendix B, Tables B7-B8.

82. Solidified/stabilized solids and leachate contaminant concentrations in the sequential batch leach tests for solidified/stabilized New Bedford Harbor sediments are presented in Appendix B, Tables B10-B33. The data in these tables were used to plot desorption isotherms for each contaminant and each S/S process (Figures B1-B123). Several different types of desorption isotherms were obtained. In some cases, contaminant release followed classical sorption models; in others, it did not. In some cases the release characteristics were not well defined.

83. A classification scheme was developed to provide a convenient framework for interpreting the desorption isotherms. Classical isotherm models (Voice and Weber 1983) were fit to selected experimental data using linear regression. Three models were used that approximated selected experimental data: linear, Freundlich, and Langmuir isotherm models. Four additional

models, no-release, minimal-release, clustered, and reverse-slope (nonconstant partitioning), were also necessary to characterize cases when no or only small amounts of contaminant were detected in the leachate, a well-defined relationship between solid and aqueous phases was not obtained, or contaminant concentrations in the leachate increased with successive leaching steps, respectively. Thus, the data collected from the sequential batch leach tests fall into five general categories: no-release, minimal-release, well-defined desorption (linear, Freundlich, and Langmuir models), reverse-slope desorption, and clustered or ill-defined release models. The general features of the desorption isotherm models are shown in Figure 21.

84. Nine sequential batch leach tests were conducted on solidified/stabilized New Bedford Harbor sediment (Table 1). Leachates were analyzed for six metals and DOC. This data set produced 63 desorption isotherms (Appendix B). The metal desorption isotherms were varied, and all five categories were represented in the metals desorption data. Tables 14 and 15 list the desorption isotherm classification for metals and DOC for each process formulation applied to midrange concentration composite and hot-spot sediments, respectively. Three solidified/stabilized sediment types were sequentially leached for PCBs--two products from solidification/stabilization of hot-spot sediment and one product from solidification/stabilization of midrange concentration composite sediment (Table 1). Leachate samples were analyzed for 23 PCB congeners, seven PCB Aroclors, and total PCB. Ninety-three desorption isotherms were developed from these data (Appendix B). The PCB desorption isotherms were less varied but more difficult to classify and interpret than the metals desorption isotherms. Table 16 lists the desorption isotherm classification for each PCB parameter according to sediment type and solidification/stabilization process. The classification criteria and characteristics of the various isotherm models are discussed below.

85. No-release isotherms. A no-release isotherm (NRI) was used to classify sequential batch leach data in which contaminants were below the detection limits in the leachate samples from all steps of the sequential batch leach test. A NRI isotherm indicates that there is no potential for contaminant leaching over repeated challenges with clean water. The cadmium and zinc desorption isotherms for the midrange concentration composite sediment processed using portland cement with Firmix were classified as NRIs. Some of the PCB data were also classified as NRIs.

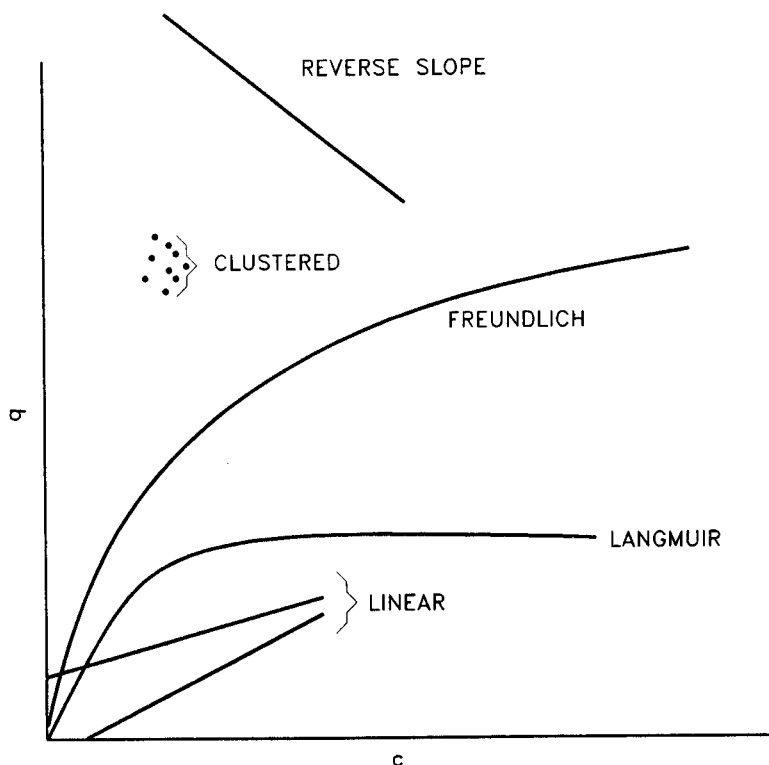

Figure 21. Graphical representation of selected desorption isotherm models

Aroclors 1016, 1221, 1232, 1248, and 1260 were below the detection limit (0.0001 mg/l) in all leachates from solidified/stabilized sediment. This is not surprising since these Aroclors were below the detection limit (0.01 mg/kg) in the untreated and solidified/stabilized sediments. The sequential batch leach data for PCB congener C185, a PCB congener that was detected in untreated and solidified/stabilized sediments, produced NRIs for solidified/stabilized hot-spot sediment. This congener did leach from untreated sediments and was detected in some leachates from the single-step batch leach tests conducted on solidified/stabilized midrange concentration composite sediment.

86. Minimal-release isotherms. For some of the sequential batch leach data, the contaminant concentrations were below or near the detection limit in most but not all of the leachate samples. This type of data was classified as minimal-release desorption isotherms (MRI). Since MRIs characterize contaminants that typically leach at or near the detection limit, these isotherms are indicative of solidified/stabilized sediment that does not have a significant

Table 14
Classification of Metal and DOC Desorption Isotherms for
Solidified/Stabilized Midrange Concentration
Composite Sediment

<u>Contaminant</u>	<u>Process</u>						
	<u>0.1 PC</u>	<u>0.2 PC</u>	<u>0.3 PC</u>	<u>0.2 PC/ 0.1F</u>	<u>0.15 PC/ 0.15 F</u>	<u>0.1 PC/ 0.2 F</u>	<u>0.3 STC</u>
Cadmium	MRI	MRI	MRI	NRI	NRI	NRI	LDI
Chromium	RSI	RSI	LgDI	RSI	LDI	RSI	RSI
Copper	FDI	FDI	FDI	FDI	FDI	FDI	FDI
Lead	*	*	*	LDI	LDI	LDI	LDI
Nickel	LDI	FDI	FDI	FDI	FDI	LDI	LDI
Zinc	MRI	MRI	CDI	NRI	NRI	NRI	**
DOC	FDI	LgDI	FDI	LgDI	FDI	FDI	LDI

* Insufficient data for curve fitting.

** Data rejected due to contamination in blanks.

Note: MRI = minimal-release isotherm, NRI = no-release isotherm, LDI = linear desorption isotherm, RSI = reverse-slope isotherm, LgDI = Langmuir desorption isotherm, FDI = Freundlich desorption isotherm, and CDI = clustered desorption isotherm.

potential for contaminant release. Five cadmium desorption isotherms and two zinc desorption isotherms were MRIs. Several PCB desorption isotherms were classified as MRIs. These included PCB congeners C77, C82, C105, C143, and C180 for hot-spot sediment solidified/stabilized with the STC additive, PCB congeners C105, C143, C167, and C180 for hot-spot sediment solidified/stabilized with portland cement, and PCB congeners C7, C82, C105, C136, C138, C143, C155, C167, C180, and C185 for the midrange concentration composite sediment solidified/stabilized with the STC additive.

87. Classical sorption isotherms. Classical sorption isotherms describe a contaminant-solidified/stabilized sediment system in which the transfer of leachable contaminant from the solid to the aqueous phase is a reversible

Table 15
Classification of Metal and DOC Desorption for
Solidified/Stabilized Hot-Spot Sediment

<u>Contaminant</u>	<u>Solidification/Stabilization Process</u>	
	<u>0.3 PC</u>	<u>0.3 STC</u>
Cadmium	MRI	MRI
Chromium	LDI	RSI
Copper	FDI	FDI
Lead	LDI	LDI
Nickel	FDI	LDI
DOC	LDI	LDI

Note: Isotherm abbreviations are defined in Table 14.

process that can be modeled by one of three classical isotherm equations (linear, Freundlich, or Langmuir) and the leachable contaminant concentration in the solid phase is high enough to support contaminant concentrations in most of the sequential leach steps that are well above the detection limit.

88. Visual inspection of the desorption isotherms for copper, nickel, and DOC (Appendix B) indicated a curvilinear relationship between solid and aqueous phase contaminant concentrations. One chromium and one lead desorption isotherm appeared to be curvilinear also. When desorption isotherm data show a nonlinear relationship between solid and aqueous phase contaminant concentrations at equilibrium, curvilinear models can be applied. Two equations commonly used to model curvilinear sorption data are the Freundlich and Langmuir equations, Equations 4 and 5 below, respectively (Weber 1972).

$$q = aC^{1/n} \quad (4)$$

Table 16

Classification of PCB Desorption Isotherms for Solidified/Stabilized
New Bedford Harbor Sediment

<u>PCB Parameter*</u>	<u>Solidified/Stabilized Sediment</u>		
	<u>0.3 STC Midrange</u>	<u>0.3 STC Hot-Spot</u>	<u>0.3 PC Hot-Spot</u>
A1016	NRI	NRI	NRI
A1221	NRI	NRI	NRI
A1232	NRI	NRI	NRI
A1242	CDI	CDI	CDI
A1248	NRI	NRI	NRI
A1254	CDI	CDI	CDI
A1260	NRI	NRI	NRI
C7	MRI	CDI	CDI
C8	CDI	LDI	CDI
C28	CDI	CDI	CDI
C44	RSI	CDI	CDI
C49	CDI	CDI	CDI
C50	CDI	CDI	CDI
C52	RSI	CDI	CDI
C70	RSI	CDI	CDI
C77	RSI	MRI	RSI
C82	MRI	MRI	CDI
C87	CDI	CDI	CDI
C97	CDI	CDI	RSI
C101	RSI	CDI	RSI
C105	MRI	MRI	MRI
C118	RSI	CDI	CDI
C136	MRI	CDI	CDI
C138	MRI	RSI	CDI
C143	MRI	MRI	MRI
C153	CDI	RSI	CDI
C155	MRI	CDI	CDI
C167	MRI	RSI	MRI
C180	MRI	MRI	MRI
C185	MRI	NRI	NRI
TPCB	CDI	CDI	LDI

* See Table 5 for PCB identification key.

$$q = \frac{QbC}{1 + bC} \quad (5)$$

where a (in litres per kilogram) and n (dimensionless) are Freundlich characteristic constants, b is the Langmuir constant related to entropy (dimensionless), and Q is the monolayer sorption capacity (in milligrams per kilogram).

89. Model parameters were determined by fitting experimental data to the linearized forms of the Freundlich and Langmuir equations. The linearized Freundlich equation takes the form

$$\ln q = \ln a + \frac{1}{n} \ln C \quad (6)$$

and the linearized Langmuir equation takes the form

$$\frac{1}{q} = \frac{1}{Q} + \left(\frac{1}{bQ}\right) \left(\frac{1}{C}\right) \quad (7)$$

A linear desorption model was also applied to the copper, nickel, and DOC desorption data using Equation 8 below.

$$q = K_d C + q_r \quad (8)$$

where

K_d = distribution coefficient, ℓ/kg

q_r = contaminant concentration in the solid phase resistant to leaching, mg/kg

In this model, the relationship between the solid phase concentration, q , and the aqueous phase concentration, C , is linear, and therefore two parameters are needed to describe the relationship, a distribution coefficient, K_d , that relates the leachable solid phase concentration to the aqueous phase concentration and the solid phase concentration resistant to leaching, q_r .

90. Selection of a model equation for classical desorption isotherms was based on a determination of best fit using regression analysis. The model that resulted in the largest correlation coefficient (r^2 value) was selected

as the model that most closely fit the experimental data. The linear, Freundlich, and Langmuir model parameters for copper, nickel, and DOC determined by linear regression are presented in Table 17. Also presented in Table 17 are model parameters for one set of chromium and one set of lead data from solidified/stabilized midrange concentration composite sediment. The desorption isotherms for these data (Figures B16 and B25, respectively) were somewhat curved. Curvilinear models were, therefore, applied to these desorption isotherms.

91. The coefficients of determination (r^2 values) in Table 17 show that the isotherm model of best fit was contaminant dependent and that the curvilinear models generally provided better fit than the linear model. The Freundlich model fit the copper and, in most cases, the nickel and DOC desorption data better than the Langmuir or linear models. The linear model provided the best fit for four nickel desorption isotherms, the one lead desorption isotherm that appeared to be curvilinear, and one DOC desorption isotherm. The Langmuir model provided the best fit for two DOC desorption isotherms and the one chromium desorption isotherm showing curvilinear features.

92. The linear desorption model was also applied to other metal desorption data that were not classified as no-release, minimal-release, Freundlich, Langmuir, or reverse-slope isotherms (discussed later in this report). Table 18 lists the results of linear regression for selected sets of metal desorption data. Nine additional sets of desorption data were classified as linear desorption isotherms on the basis of r^2 values greater than 0.25.

93. Trends in the metal desorption data classified as MRIs (Tables 14 and 15) were evaluated for linear desorption by examining plots of average leachate contaminant concentration versus step number for similarity to Figure 22. Figure 23 illustrates the typical linear desorption noted in average leachate concentration versus step number plots for all but one of the MRIs. Cadmium release for the 0.1 portland cement to 1.0 sediment process for mid-range concentration composite sediment was the single exception. Thus, six of the seven MRIs for metals showed linear desorption characteristics.

94. Very few PCB desorption data sets showed classical sorption characteristics. Only two PCB desorption isotherms, PCB congener C8 for hot-spot sediment solidified/stabilized with the STC additive and total PCB for

Table 17
Linear, Freundlich, and Langmuir Curve Fit Parameters for Selected
Desorption Isotherms from Solidified/Stabilized
New Bedford Harbor Sediments

Process/ Desorption Isotherm	Linear			Freundlich			Langmuir		
	r ²	q _r	K _d	r ²	a	n	r ²	Q	b
<u>Midrange</u>									
0.1 PC									
Copper	0.96	1,178.07	3.36	0.99	1158.95	47.84	0.95	1,231.53	8.64
Nickel	0.99	91.25	1.95	0.96	93.38	93.48	0.74	92.94	371.04
DOC	0.96	12,052.20	2.67	0.99	10,745.44	32.07	0.93	12,987.01	0.31
0.2 PC									
Copper	0.96	903.43	5.50	0.99	898.76	43.62	0.98	947.87	13.03
Nickel	0.97	76.54	3.11	0.99	79.08	70.21	0.90	78.82	288.36
DOC	0.65	15,248.57	2.41	0.69	14,299.16	54.85	0.74	16,129.03	0.53
0.3 PC									
Chromium	0.67	349.38	15.30	0.67	350.15	545.85	0.68	350.75	13,199.08
Copper	0.94	735.93	3.82	0.99	737.13	66.50	0.98	759.88	263.20
Nickel	0.96	67.15	2.38	0.99	69.06	86.84	0.90	68.83	415.09
DOC	0.89	12,805.88	3.40	0.91	11,895.95	44.25	0.87	13,513.51	0.63
0.2 PC:0.1 F									
Copper	0.96	700.18	4.90	0.99	700.83	48.49	0.97	730.99	19.54
Nickel	0.97	59.49	2.61	0.99	61.06	110.58	0.86	60.64	867.95
Lead	0.58	434.06	8.49	0.57	435.99	874.13	0.56	435.16	15,527.03
DOC	0.88	12,470.82	3.66	0.96	11,058.71	29.77	0.97	13,513.51	0.31
0.15 PC:0.15 F									
Copper	0.96	767.46	3.76	0.99	761.13	64.05	0.96	793.65	25.71
Nickel	0.97	63.53	2.02	0.98	64.71	167.87	0.81	64.35	1,726.56
DOC	0.92	12,379.07	3.25	0.99	11,047.48	31.58	0.96	13,333.33	0.34
0.1 PC:0.2 F									
Copper	0.96	771.09	3.39	0.99	770.09	62.35	0.93	798.09	23.20
Nickel	0.99	63.92	2.02	0.95	65.00	188.11	0.70	64.66	2,209.29
DOC	0.92	12,305.65	3.20	0.99	10,929.60	30.59	0.96	13,333.33	0.32
0.3 STC									
Copper	0.98	730.15	7.36	0.99	732.74	39.90	0.97	769.23	16.88
Ni	0.99	58.63	2.03	0.95	60.17	104.82	0.71	59.82	759.86
DOC	0.99	13,109.97	4.79	0.98	12,254.76	44.53	0.91	13,888.89	0.86
<u>Hot-Spot</u>									
0.3 PC HOT									
Copper	0.93	589.99	3.07	0.99	588.74	49.84	0.95	615.76	18.04
Nickel	0.96	48.08	2.25	0.99	50.30	47.65	0.85	50.30	180.74
DOC	0.98	10,910.90	3.07	0.97	9,809.32	32.48	0.87	11,764.70	0.40
0.3 STC HOT									
Copper	0.98	567.69	5.75	0.99	570.64	41.53	0.95	596.30	19.73
Nickel	0.99	42.19	2.11	0.94	43.51	95.73	0.70	43.11	927.84
DOC	0.99	11,312.50	3.79	0.98	10,344.90	36.40	0.89	12,048.20	0.55

Table 18

Linear Curve Fit Parameters for Selected Desorption Isotherms from
Solidified/Stabilized New Bedford Harbor Sediments

<u>Process/Desorption Isotherms</u>	<u>r²</u>	<u>q_r</u>	<u>K_d</u>
	<u>Midrange</u>		
0.3 PC			
Zinc	0.26	1512.25	12.50
0.15 PC:0.15 F			
Chromium	0.86	371.46	45.12
Lead	0.32	438.52	10.50
0.1 PC:0.2 F			
Lead	0.45	444.74	9.40
0.3 STC			
Cadmium	0.63	18.10	1.78
Lead	0.54	417.66	5.92
	<u>Hot-Spot</u>		
0.3 PC			
Chromium	0.43	278.15	8.79
Lead	0.27	365.00	7.43
0.3 STC			
Lead	0.84	344.63	5.56

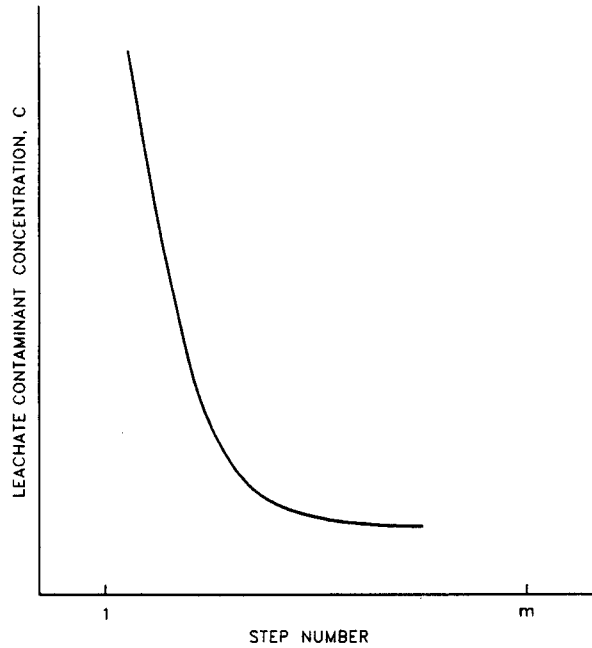

Figure 22. Shape of leachate contaminant concentrations versus step number curve for linear desorption model

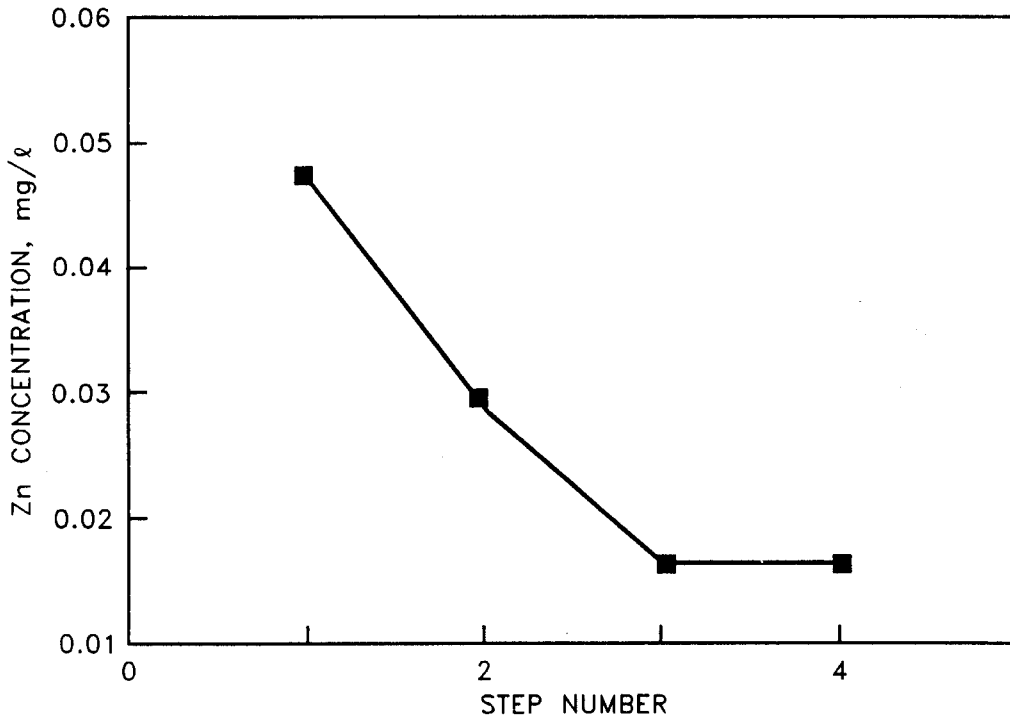

Figure 23. Average zinc leachate concentration in sequential batch leach test for midrange concentration composite sediment solidified/stabilized with 0.1 portland cement:1.0 sediment (wet sediment basis)

hot-spot sediment solidified/stabilized with portland cement, were classified as linear desorption isotherms. The PCB MRIs in Table 16 were evaluated for linear desorption trends as described above for metals, but none showed linear desorption characteristics.

95. Reverse-slope isotherms. A reverse-slope desorption isotherm (RSI) is obtained from data in which the leachate contaminant concentration increases with each step in the sequential batch leach test. Six chromium desorption data sets were classified as reverse-slope desorption isotherms (Tables 14 and 15). Eleven PCB desorption data sets were classified as RSIs (Table 16). In a reverse-slope desorption isotherm, the slope of the q versus C relationship is the reverse (opposite sign) of the classical isotherm slopes. To satisfy mass balance, it would be expected that the reverse-slope isotherms would not continue indefinitely, but no turn toward a classical isotherm model was evident after four leaching steps. Linear regression could be applied to these data to obtain values for the slopes, but the linear desorption model (Equation 8) is not applicable because negative distribution coefficients are not physically possible. Reverse-slope isotherms imply that the distribution coefficient is not constant (see Report 5). This concept is illustrated in Figure 24. As shown, the distribution coefficient (K_1 , K_2 , etc.) changes with each step in the sequential leach test as the solid phase is contacted with clean water until the isotherm turns and takes on a classical isotherm form. Reverse-slope isotherms have not been widely reported in the literature, and the reasons for this type of desorption are not known. Possible explanations for nonconstant distribution coefficients for untreated New Bedford Harbor sediment are discussed in Report 5, but these explanations give no indication why some chromium desorption data sets for solidified/stabilized New Bedford Harbor sediment would be classified as RSIs.

96. Clustered isotherms. By default, those desorption data sets that were not classified as no-release, minimal-release, classical sorption, or reverse-slope isotherms were classified as clustered desorption isotherms (CDI). Desorption isotherms for these data sets produced a cluster of points with no well-defined relationship between solid and aqueous phase contaminant concentrations. One metal data set for zinc was classified as a clustered isotherm (Table 14). No other metal or DOC data sets were classified as CDIs.

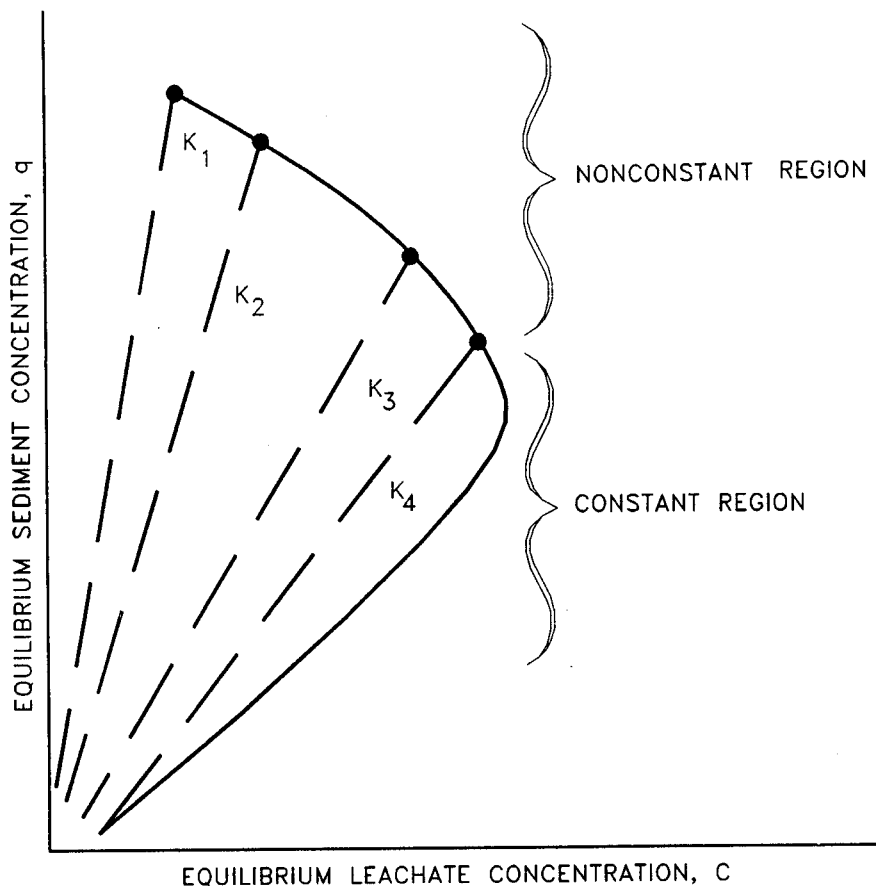

Figure 24. Desorption isotherm demonstrating nonconstant and constant partitioning during sequential batch leaching

97. Forty-two PCB desorption data sets were classified as clustered desorption isotherms (Table 16). This classification was chosen for these desorption data because regression statistics for the linear desorption model showed poor fit (Tables 19-21). Regression statistics were not calculated for the Langmuir and Freundlich models because well-defined curves were not evident. Clustered desorption isotherms were obtained primarily because leachate PCB concentrations were relatively constant during the sequential leach tests. The trend for small changes in leachate PCB concentrations with step number in the sequential leach tests for solidified/stabilized sediment is shown in Figures 19 and 20. Unless there are significant differences in leachate PCB concentrations that tend to either increase or decrease during the sequential batch leach test, plots of solid phase PCB concentration (q)

Table 19

Linear Curve Fit Parameters for PCB Desorption Isotherms for Midrange Concentration Composite Sediment Processed with STC Proprietary Additive

<u>Contaminant</u>	<u>r²</u>	<u>q_r</u> <u>mg/kg</u>	<u>K_d</u> <u>l/kg</u>
Aroclor 1242	0.495	782.686	5.76
Aroclor 1254	0.015	311.649	2.93
Total PCB	0.524	1,096.650	5.19
C7	0.976	0.257	-6.760
C8	0.569	79.333	-5.54
C28	0.024	133.318	1.91
C44	0.869	30.001	-7.89
C49	0.720	13.667	-6.85
C50	0.009	55.989	2.17
C52	0.298	81.332	-3.787
C70	0.164	23.333	-2.57
C77	0.814	105.667	-4.53
C82	--	--	--
C87	0.813	11.533	-6.36
C97	0.761	23.667	-8.05
C101	0.812	37.000	-6.76
C105	0.914	5.434	-4.536
C118	0.867	18.667	-7.16
C136	0.139	9.166	-1.18
C138	0.928	12.333	-5.58
C143	0.949	7.067	-4.95
C153	0.736	20.333	-6.17
C155	--	--	--
C167	--	--	--
C180	0.552	2.767	-10.47
C185	0.167	3.405	-2.23

Table 20

Linear Curve Fit Parameters for PCB Desorption Isotherms for
Hot-Spot Sediment Processed with STC Proprietary Additive

<u>Contaminant</u>	<u>r²</u>	<u>q_r mg/kg</u>	<u>K_d l/kg</u>
Aroclor 1242	0.009	2,632.78	-0.588
Aroclor 1254	0.0001	798.301	0.12
Total PCB	0.024	3,766.08	-1.05
C7	0.090	0.786	-2.48
C8	0.514	239.668	11.720
C28	0.005	393.270	1.26
C44	0.002	108.322	-0.311
C49	0.167	32.666	-3.650
C50	0.484	170.929	2.42
C52	0.005	190.985	-0.474
C70	0.026	122.996	-1.489
C77	0.601	372.665	-2.47
C82	--	--	--
C87	0.028	41.331	-0.450
C97	0.024	91.329	-0.402
C101	0.072	139.996	-1.46
C105	0.092	13.500	-1.17
C118	0.217	71.666	-2.70
C136	0.101	36.667	-1.65
C138	0.955	23.333	-2.62
C143	0.009	17.333	-0.486
C153	0.967	40.667	-2.87
C155	--	--	--
C167	0.865	10.433	-2.89
C180	0.012	3.600	0.810
C185	No-release isotherm		

Table 21

Linear Curve Fit Parameters for PCB Desorption Isotherms for Hot-Spot
Sediment Processed with Portland Cement

<u>Contaminant</u>	<u>r²</u>	<u>q_r</u> <u>mg/kg</u>	<u>K_d</u> <u>l/kg</u>
Aroclor 1242	0.037	1,882.30	1.197
Aroclor 1254	0.229	1,383.32	-3.321
Total PCB	0.053	3,282.18	1.535
C7	0.172	1.063	-3.512
C8	0.052	139.006	3.76
C28	0.022	140.241	3.37
C44	0.236	61.338	-9.77
C49	0.303	28.333	-4.417
C50	0.264	64.909	6.03
C52	0.008	133.273	-0.296
C70	0.548	65.999	-5.26
C77	0.911	316.666	-3.248
C82	--	--	--
C87	0.025	84.000	-1.29
C97	0.844	188.333	-4.38
C101	0.852	80.000	-5.14
C105	0.985	9.367	-4.48
C118	0.624	102.333	-3.919
C136	0.073	86.331	-0.784
C138	0.597	58.666	-2.496
C143	0.095	37.666	-0.946
C153	0.034	115.332	-0.560
C155	--	--	--
C167	0.999	25.003	-2.490
C180	0.017	17.466	-0.393
C185	--	--	--

versus leachate PCB concentration (C) produce scattered points, not well-defined relationships.

98. Clustered PCB desorption isotherms have been interpreted as clustering about some point (C,q) that represents an overall or net distribution coefficient (K_d) (Environmental Laboratory 1987). Each point in the cluster is an approximation of K_d , with K_d defined as the ratio of the solid phase PCB concentration to the leachate PCB concentration ($K_d = q/C$). This interpretation assumes that (a) classical linear desorption governs, (b) the desorption isotherm goes through the point (C = 0, q = 0), and (c) the distribution coefficient is very large. When K_d is very large, the leachate concentration changes relatively little with repeated challenges by clean water, regardless of the solid phase concentration. Clustering instead of well-defined linear desorption results because the small differences in leachate PCB concentration that a large distribution coefficient necessitates are within the combined variability of batch testing and chemical analysis.

99. Figure 25 illustrates the above interpretation. In the figure, desorption data for Aroclor 1242 are presented as normally plotted and in the insert with the data plotted on a scale using the point (C = 0, q = 0) as the origin. In the insert, the cluster is reduced to a horizontal line. The points on this line represent equilibrium partitioning (assuming linear desorption and complete reversibility of the sorption process) and the variability in dissolved PCB concentration that is associated with batch testing polluted sediment.

100. Using the above assumptions, distribution coefficients were calculated by computing the average K_d from the point estimates provided by the sequential batch leach tests. The PCB distribution coefficients determined by this method ranged from 10^4 to 10^7 l/kg (Table 22).

101. Relatively constant PCB leachate concentrations during sequential batch leaching can also be interpreted as solubility-limited release. The linear desorption model is not appropriate beyond the solubility limit. As shown in Figure 26, beyond a critical PCB concentration in the solid phase, the concentration in the leachate is constant and equals the solubility. The solubility of PCBs in alkaline water high in elements commonly found in setting agents, such as calcium, is not known but could be the controlling factor. The solubility of Aroclor 1242, for example, is approximately 0.13 mg/l in freshwater at 11° C (Dexter and Pavlou 1978). Some Aroclor 1242

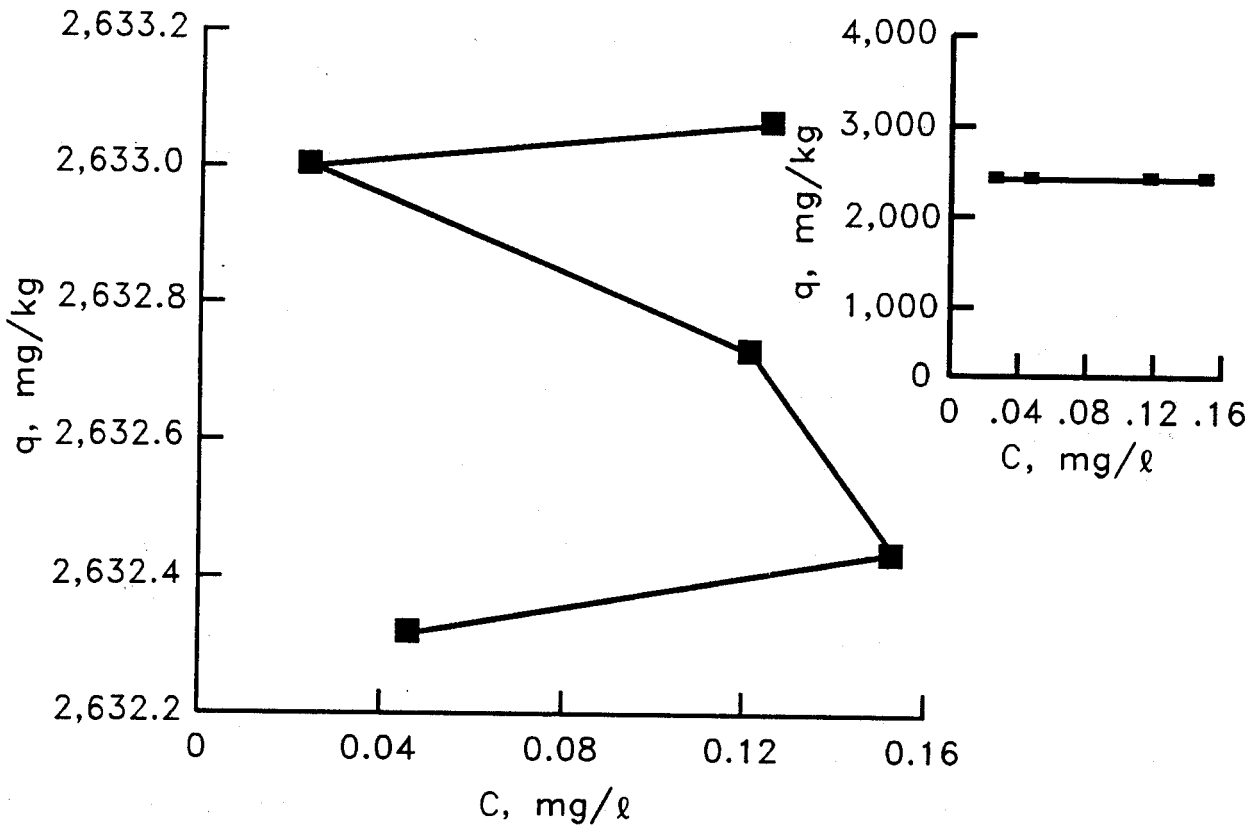

Figure 25. Aroclor 1242 desorption isotherm for hot-spot sediment solidified/stabilized using STC proprietary additive

concentrations in the sequential batch leachates for solidified/stabilized New Bedford Harbor sediment were near or slightly greater than this value.

102. Other explanations of the clustered PCB desorption isotherms are possible. For example, it is possible that the leachate PCB concentrations were controlled by diffusion from within the particles. Regardless of the correct theoretical interpretation, two important results are provided by the clustered desorption isotherms obtained from sequential batch leach tests for solidified/stabilized New Bedford Harbor sediments. The leachate PCB concentrations were lower than in the sequential batch leach tests for untreated sediment, and unlike the PCB leachate concentrations in the sequential batch leach tests for untreated sediment, they tend to remain relatively constant with repeated clean water challenges.

Table 22

PCB Distribution Coefficients for Solidified/Stabilized
New Bedford Sediments (0.3 Additive to 1.0 Wet Sediment)

Contaminant	0.3 PC-HOT	0.3 STC-HOT	0.3 STC-MID
Aroclor 1016	--	--	--
Aroclor 1221	--	--	--
Aroclor 1232	--	--	--
Aroclor 1242	23,476 (7,100)	41,557 (12,812)	39,298 (7,165)
Aroclor 1248	--	--	--
Aroclor 1254	513,186 (213,754)	177,059 (21,729)	170,459 (9,513)
Aroclor 1260	--	--	--
Total PCB	36,473 (10,710)	50,126 (15,559)	50,242 (9,922)
C7	15,882 (2,520)	18,209 (3,689)	20,614 (2,806)
C8	5,053 (604)	14,037 (1,468)	37,365 (8,905)
C28	16,671 (1,234)	52,284 (4,299)	80,539 (10,773)
C44	36,969 (2,659)	75,027 (13,817)	144,268 (47,150)
C49	118,334 (20,962)	129,237 (25,101)	178,929 (38,560)
C50	10,586 (1,176)	34,320 (7,312)	47,787 (2,630)
C52	41,610 (8,668)	122,608 (47,211)	175,268 (49,132)
C70	94,816 (15,019)	156,757 (23,390)	300,980 (74,637)
C77	6,810,294 (5,559,221)	15,200,015 (8,057,592)	2,623,616 (1,788,596)
C82	--	--	--
C87	3,490,924 (1,104,639)	502,680 (154,955)	533,231 (174,863)
C97	1,194,428 (271,373)	454,306 (109,682)	467,536 (100,592)
C101	247,147 (55,448)	215,920 (45,048)	379,474 (133,487)
C105	649,391 (158,229)	895,745 (248,813)	345,817 (84,729)
C118	1,126,464 (240,310)	686,208 (212,506)	477,150 (144,426)
C136	2,726,182 (1,396,470)	1,818,374 (676,161)	624,665 (165,212)
C138	1,912,108 (948,224)	588,045 (134,065)	637,246 (218,814)
C143	2,065,932 (708,462)	1,266,482 (255,717)	603,470 (75,971)
C153	3,165,779 (1,889,351)	1,097,941 (668,579)	726,748 (307,347)
C155	--	--	--
C167	1,597,430 (498,912)	437,881 (201,188)	--
C180	1,330,270 (278,400)	255,437 (45,738)	222,768 (20,902)
C185	--	86,833 (-)	306,448 (30,455)

Note: Values expressed in litres per kilogram (standard error).

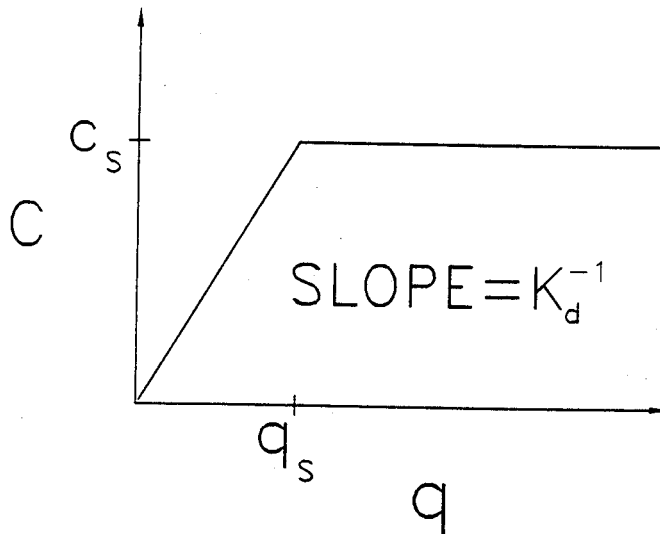

Figure 26. Limits of applicability of linear desorption model

Summary of leach data

103. The technical feasibility of chemically stabilizing contaminants in New Bedford Harbor sediments by S/S processing was investigated in sequential and single-step batch leach tests. The purpose of this testing was to develop data for evaluating disposal alternatives for dredged material from New Bedford Harbor that involved S/S processing.

104. Two approaches to data reduction were implemented. In the first approach, determination of chemical stabilization effectiveness by S/S processing was based on comparison of the total contaminant mass leached (normalized for additive dosages) in a fixed number of leaching cycles. The second involved desorption isotherm analysis. Ideally, desorption isotherm analysis is a technique for estimating contaminant release for an infinite number of leaching cycles. The solid phase contaminant mass that is leachable is estimated by curve fitting. Estimates for untreated and solidified/stabilized sediment are then normalized and compared. However, this approach is limited to classical desorption isotherms, and, as previously discussed, all the untreated sediment desorption isotherms were reverse-slope desorption isotherms. Since the leachable contaminant mass cannot be predicted from reverse-slope isotherms, desorption isotherm analysis was restricted to evaluation of leaching characteristics and determination of model parameters for selected data.

105. If S/S processing chemically stabilizes all contaminants such that they are resistant to aqueous leaching, no contaminant mass would desorb from the solidified/stabilized material during leach testing. Thus, if complete contaminant immobilization by chemical stabilization had occurred, all the cumulative mass leached calculations would have yielded less-than values, and all the desorption isotherms would have been no-release desorption isotherms. None of the S/S processes described in this report chemically stabilized all contaminants. The cumulative mass leached for cadmium, lead, zinc, and PCBs for solidified/stabilized sediment was reduced compared with the amounts leached from untreated sediment. In some cases, cadmium and zinc were completely immobilized. Desorption isotherm analysis showed significant differences in leaching characteristics for untreated and solidified/stabilized sediments.

106. The cumulative mass release calculations showed mobilization, not immobilization, of copper and nickel. As previously noted, all of the untreated sediment desorption isotherms were reverse-slope isotherms, for which the total mass leachable cannot be predicted. The copper and nickel desorption isotherms for solidified/stabilized sediments were classical desorption isotherms for which the total mass leachable can be estimated. For untreated sediments (reverse-slope desorption), copper and nickel leachate concentrations monotonically increased during sequential batch leaching. For solidified/stabilized sediments (classical desorption), copper and nickel concentrations monotonically decreased during sequential batch leaching. These differences taken alone would be expected to show chemical stabilization, not mobilization. The conversion of contaminant interphase transfer to desorption processes that show decreased contaminant release as leaching proceeds would be expected to be an improvement over processes that show increased contaminant release as leaching proceeds. However, copper and nickel concentrations in leachates from solidified/stabilized sediments were higher than copper and nickel concentrations in leachates from untreated sediments. Apparently, the higher concentrations are related to the alteration of the processes controlling interphase transfer of copper and nickel.

107. The magnitude of the mobilization effect applies only over the leaching cycles used to calculate mass leached, since the mass leached from untreated sediments was increasing and the mass leached from solidified/stabilized sediment was decreasing at the end of the sequential batch leach

tests. It is not known how many leaching steps would be required before the copper and nickel concentrations in leachates from untreated sediment would begin to decrease. A reverse-slope desorption isotherm cannot continue indefinitely and satisfy conservation of mass.

108. The cumulative mass leached and the leaching characteristics of PCBs were significantly altered by S/S processing. The cumulative masses leached were reduced by factors of 10 to 100. The leaching characteristics were converted from reverse-slope desorption in untreated sediment to primarily ill-defined desorption in which leachate PCB concentrations remained relatively constant during sequential leaching. The theoretical implications of these data are not well understood, but it is clear that S/S processing reduced leachate PCB concentrations and cumulative masses leached by altering the interphase transfer process.

Limitations of Laboratory Evaluations

109. Several important aspects of field application were not addressed in this laboratory study. Topics beyond the scope of this investigation include scale-up factors, long-term stability of the solidified/stabilized sediment, and engineering economy. In the field, strengths may be lower than those obtained in the laboratory due to lower mixing efficiency and dosage control. These factors are best evaluated in a field demonstration. Temperature is another processing variable that was not investigated that can be important.

110. Caution must also be exercised in extrapolating the desorption data to the field. The surface area for leaching in the field may be different from that in the sequential batch leach tests. Since the solidified/stabilized sediment samples were ground, the surface area-to-mass ratio in the laboratory tests is probably higher than that in the field. However, the laboratory leach data are not necessarily conservative, since the impact of humidity control during curing and grinding after curing on contaminant mobility is poorly understood.

111. The sequential batch leach tests and the methods of data analysis in this report were designed to provide a basis for evaluating chemical stabilization effectiveness and not for predicting field leachate concentrations. A permeant-porous media model could be used as a worst-case model

(Myers and Hill 1986). However, it should be realized that such a model may not be realistic unless water flows through the solidified/stabilized material. Mass transport models with other assumptions, such as the solid phase diffusion approach (Coté and Isabel 1984), might be more appropriate and give more reasonable results, depending on the physical properties of the solidified/stabilized material, in particular, durability. Further consideration is given to these factors in the following section on the engineering basis for contaminant immobilization by S/S processing.

PART V: ENGINEERING BASIS FOR CONTAMINANT IMMOBILIZATION

112. Solidification/stabilization technology has the potential for immobilizing contaminants and reducing the pollutant potential of contaminated dredged material by alteration of physical and chemical properties. Conversion of a semisolid to a solid monolith (solidification) provides a barrier to contaminant leaching by reducing the accessibility of water to contaminated solids. Conversion of contaminants to forms that are resistant to aqueous leaching (chemical stabilization) provides another barrier to contaminant leaching. This combination of solidification/stabilization gives processed material structural integrity while lowering the expected leachability.

Primary Containment

113. Primary containment refers to reduced accessibility of water to the contaminated solids. The word "primary" does not mean most important, but denotes "first" as in the first barrier to contaminant migration. Potential mechanisms by which solidification reduces the accessibility of water to the contaminated solids include entrapment in a crystalline lattice with reduced permeability and coating of contaminated solids with hydration products. Figure 27 shows an idealized solidification/stabilization system in which water in the voids reacts with setting agents to form hydration products (solids). As the voids are slowly filled with hydration products, contaminated solids become entrapped in the lattice work that develops and/or coated with hydration products.

114. If the final product is sufficiently dense and impermeable, the potential for percolation of water through solidified/stabilized material is all but eliminated. Thus, the hydration reactions that occur on a microscopic scale are responsible for the development of macroscopic attributes that reduce contaminant mobility. For long-term immobilization, these macroscopic attributes must remain intact. Spalling and cracking during aging will increase permeability, and in the event the material is exposed, weathering could cause the solid matrix to deteriorate.

115. Long-term physical integrity is related to porosity and strength, properties that depend primarily on the type and dosage of setting agents

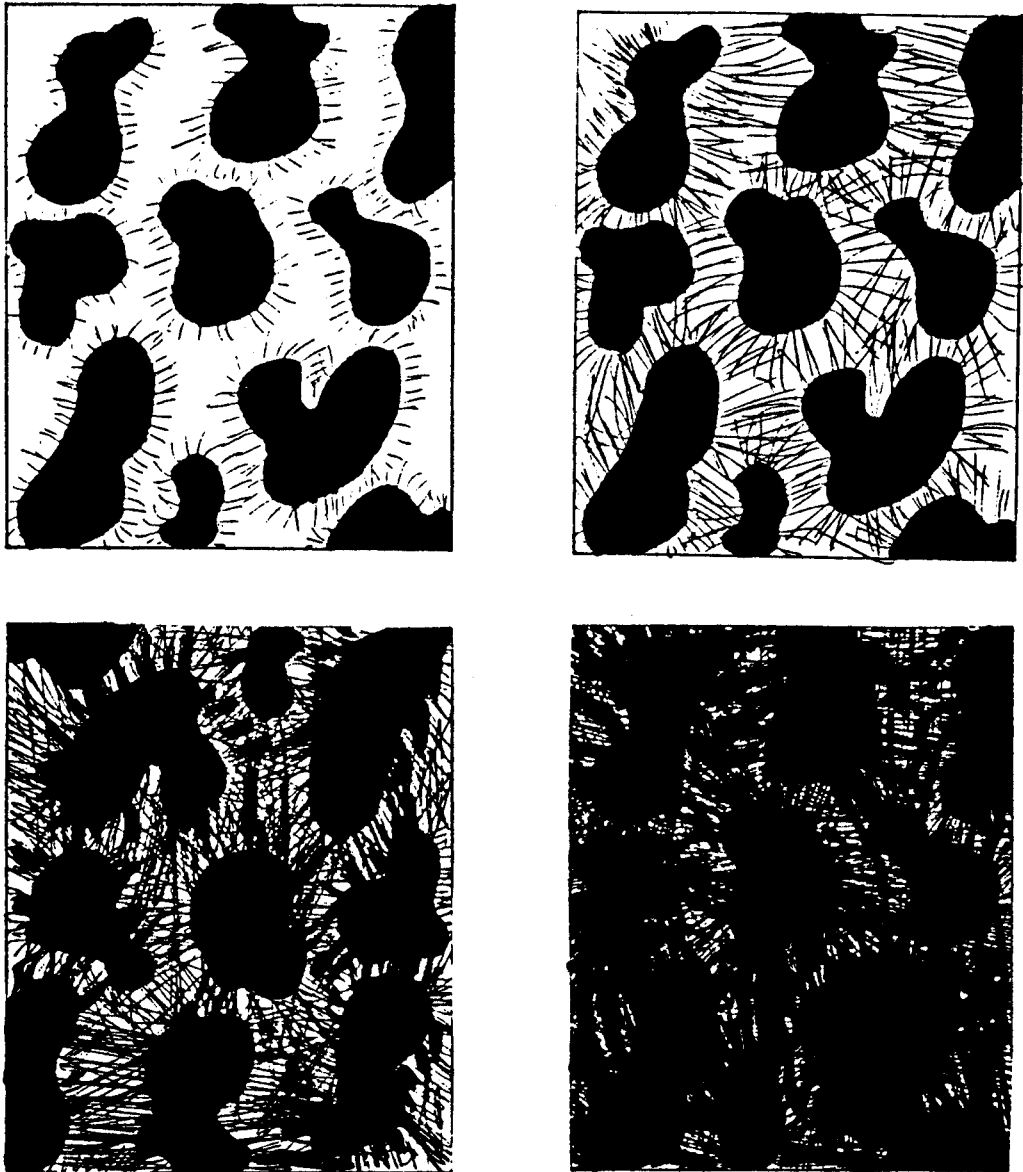

Figure 27. Development of hydration products in an ideal solidification/stabilization system

used. Porosity and strength are, therefore, important indices of probable long-term immobilization by reduced accessibility to contaminated solids.

Secondary Containment

116. Secondary containment refers to chemical stabilization. If chemical stabilization is 100-percent effective, contaminants will not leach even if water permeates the solidified/stabilized dredged material. The sequential

PART V: ENGINEERING BASIS FOR CONTAMINANT IMMOBILIZATION

112. Solidification/stabilization technology has the potential for immobilizing contaminants and reducing the pollutant potential of contaminated dredged material by alteration of physical and chemical properties. Conversion of a semisolid to a solid monolith (solidification) provides a barrier to contaminant leaching by reducing the accessibility of water to contaminated solids. Conversion of contaminants to forms that are resistant to aqueous leaching (chemical stabilization) provides another barrier to contaminant leaching. This combination of solidification/stabilization gives processed material structural integrity while lowering the expected leachability.

Primary Containment

113. Primary containment refers to reduced accessibility of water to the contaminated solids. The word "primary" does not mean most important, but denotes "first" as in the first barrier to contaminant migration. Potential mechanisms by which solidification reduces the accessibility of water to the contaminated solids include entrapment in a crystalline lattice with reduced permeability and coating of contaminated solids with hydration products. Figure 27 shows an idealized solidification/stabilization system in which water in the voids reacts with setting agents to form hydration products (solids). As the voids are slowly filled with hydration products, contaminated solids become entrapped in the lattice work that develops and/or coated with hydration products.

114. If the final product is sufficiently dense and impermeable, the potential for percolation of water through solidified/stabilized material is all but eliminated. Thus, the hydration reactions that occur on a microscopic scale are responsible for the development of macroscopic attributes that reduce contaminant mobility. For long-term immobilization, these macroscopic attributes must remain intact. Spalling and cracking during aging will increase permeability, and in the event the material is exposed, weathering could cause the solid matrix to deteriorate.

115. Long-term physical integrity is related to porosity and strength, properties that depend primarily on the type and dosage of setting agents

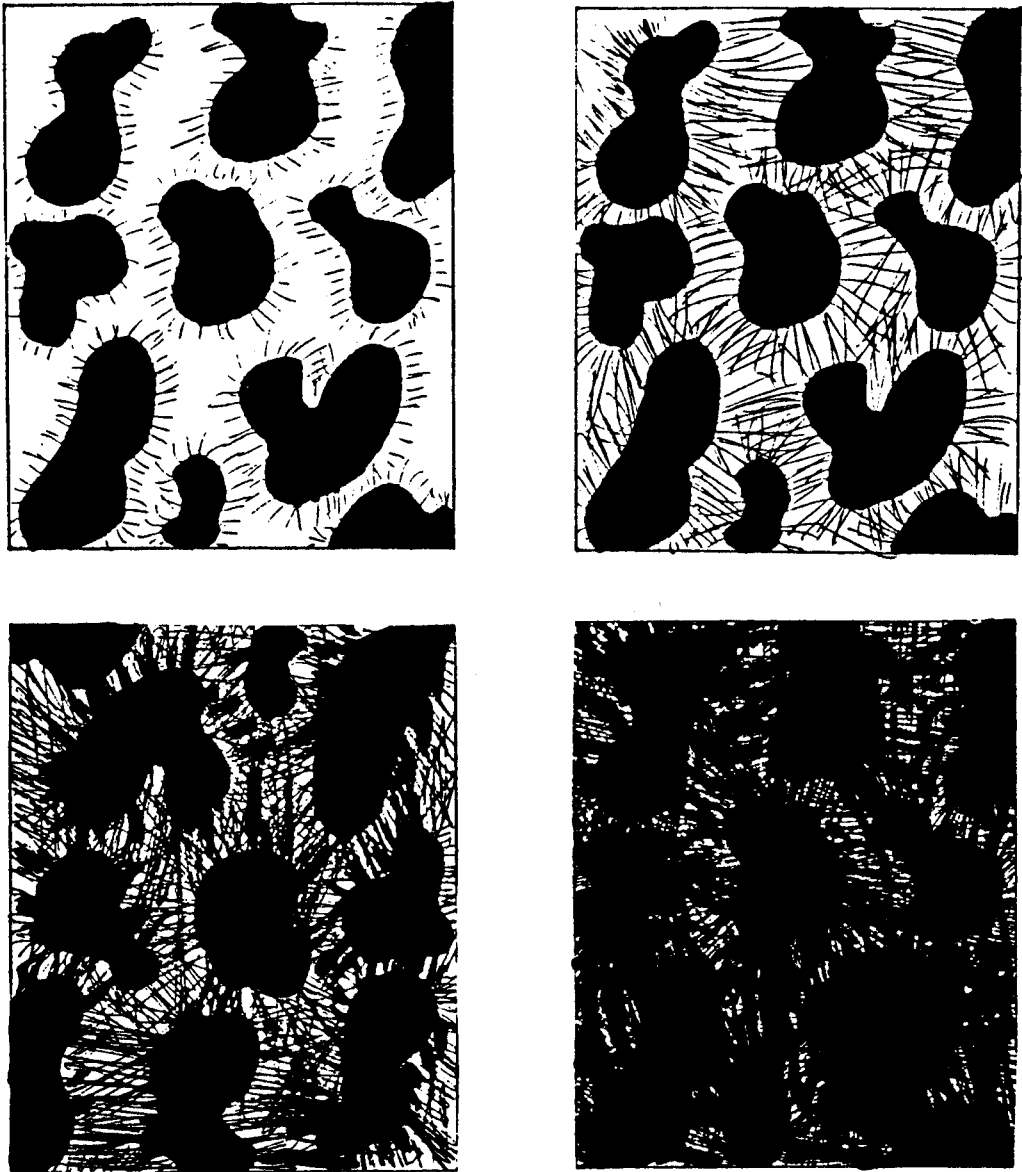

Figure 27. Development of hydration products in an ideal solidification/stabilization system

used. Porosity and strength are, therefore, important indices of probable long-term immobilization by reduced accessibility to contaminated solids.

Secondary Containment

116. Secondary containment refers to chemical stabilization. If chemical stabilization is 100-percent effective, contaminants will not leach even if water permeates the solidified/stabilized dredged material. The sequential

batch leach tests previously discussed were designed to determine the effectiveness of chemical stabilization. These tests showed that complete chemical stabilization was not achieved using various setting agents.

Contaminant Transport Models for
Solidified/Stabilized Material

117. The effectiveness of contaminant immobilization by S/S processing can be evaluated by estimating the contaminant mass leached from solidified/stabilized material in a given period. To make such estimates, theoretical models of contaminant leaching and information on disposal site hydrology and solidified/stabilized dredged material properties are needed. The assumptions and equations for two modeling approaches are discussed below.

118. Figure 28 illustrates leachate generation by percolation and surface washing of a monolithic block of solidified/stabilized dredged material. In a worst-case scenario, water infiltrates the solidified/stabilized dredged material, contaminants are leached as this water percolates through, and then the leachate generated by this process enters the environment. This is termed convective transport. In a best-case scenario, leachate is generated by diffusion-controlled transport of contaminants through the solid monolith to the surface of the monolith where leaching takes place. In the diffusion model, leachate is generated by water in contact with the surface of the monolith. The hydraulic conductivity of the solidified/stabilized dredged material is assumed to be so low that convective transport to the boundary is negligible.

Convective transport

119. The cumulative contaminant mass leached from solidified/stabilized dredged material at time t by convective transport is given by

$$CT = \int QC \, dt \quad (9)$$

where

C = contaminant concentration in leachate, g/m^3

CT = cumulative contaminant mass leached, g

Q = percolation, m^3/sec

t = time, sec

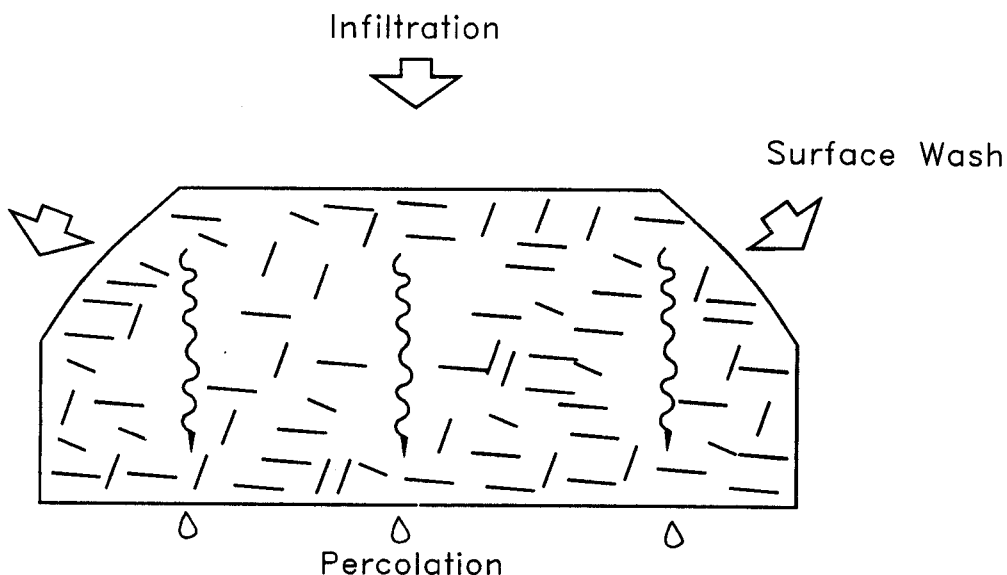

Figure 28. Contaminant leaching by percolation and surface washing of a monolithic block

Percolation depends in part on cap, liner, and solidified/stabilized dredged material properties. Percolation is also affected by local climatology. Percolation for various disposal site conditions and climatic factors can be estimated using a hydrologic model such as the Hydrologic Evaluation of Landfill Performance computer model (Schroeder et al. 1984). Chemical leach data from sequential batch leach tests can be used to estimate contaminant concentrations.

120. The accuracy of the above approach is limited primarily by uncertainty about water content, effective porosity, and hydraulic conductivity of the solidified/stabilized dredged material and the validity of extrapolating sequential batch leach data to the field. Extrapolation of chemical data from sequential batch leach tests for solidified/stabilized wastes has not been verified.

Diffusive transport

121. For negligible convective transport, leaching can be modeled as internal diffusion of contaminant from within a monolith to the surface of the monolith. The cumulative contaminant mass leached at time t for a semi-infinite medium with uniform initial contaminant concentration is given by the following equation (Godbee and Joy 1974):

$$DT = 2A_o \left(\frac{S}{V} \right) \left(\frac{D_e t}{\pi} \right)^{1/2} \quad (10)$$

where

DT = cumulative contaminant mass leached, g

A_o = initial contaminant mass in monolith, g

$$= q_o \rho_s V$$

q_o = initial contaminant solid phase concentration, g/kg

ρ_s = bulk density of solidified material, kg/m³

V = volume of solidified/stabilized material, m³

S = surface area, m²

D_e = effective diffusivity, m²/sec

t = time, sec

122. The above modeling approach has been used to evaluate solidified/stabilized radioactive waste forms (Moore, Godbee, and Kibbey 1976) and to evaluate solidified/stabilized hazardous waste (Coté and Isabel 1984). The diffusive transport equation assumes that there is no resistance to transport of contaminant into the aqueous phase at the surface of the monolith and that the solid phase contaminant concentration at the surface is always zero. Models for other assumptions are available (Moore, Godbee, and Kibbey 1976).

123. The diffusion model applies to especially dense, low-permeability material in which contaminated solids beneath the surface of the monolith are effectively isolated from the hydrologic cycle. The monolith may be in contact with the hydrologic cycle, but water does not percolate through the monolith. To isolate solidified/stabilized dredged material from the hydrologic cycle, a cap that is less permeable than the solidified/stabilized dredged material is essential. Otherwise, a hydraulic head may develop on the solidified/stabilized dredged material. Percolation will then be controlled only by the permeability of the solidified/stabilized dredged material. Mounding or sloping the top of the monolith will minimize the potential for a hydraulic head to develop.

124. Placement of solidified/stabilized dredged material such that fluctuating water table repeatedly comes in contact with the monolith will increase the potential for permeation of water into the pores of the monolith and thereby decrease the isolation of contaminated solids from the hydrologic

cycle. In this case, high-strength, low-permeability products with excellent resistance to wet-dry cycling are necessary for effective primary containment.

Convection versus
diffusion-limited leaching

125. Since disposal such that leachate generation is limited to surface washing reduces the exposure of water to contaminated surfaces across which contaminant transfer can take place, solidified/stabilized products with physical and chemical properties that limit contaminant leaching to diffusion-controlled transport should maximize contaminant immobilization. The contaminant transport mechanism that predominates is dependent on disposal site hydrology and specific properties of the solidified/stabilized product. As previously discussed, site- and product-specific information is needed to fully evaluate the relative importance of permeation and percolation.

126. An assessment without site-specific information, however, is possible if some simplifying assumptions are made. Diffusive transport (DT) modeling assumes negligible convective transport (CT). Thus, if contaminant leaching is diffusion limited, the ratio of CT to DT will be very small. This ratio is given by

$$\frac{CT}{DT} = \frac{\int QC \, dt}{2q_o \rho_s V \left(\frac{S}{V}\right) \left(\frac{D_e t}{\pi}\right)^{1/2}} \quad (11)$$

127. If the solidified/stabilized dredged material is fully saturated, percolation is one-dimensional, the hydraulic gradient is 1, and the contaminant concentration in the pore water, C , is constant, then convective transport is given by the following:

$$CT = \int QC \, dt = kACt$$

where

k = hydraulic conductivity of the monolith, m/sec

A = flow-through area, m^2

It should be realized that solidified/stabilized dredged material may never be saturated. If it does become saturated, many years may be required for this condition to develop, and the hydraulic gradient will probably be much less than one. Using the above simplifying assumptions,

$$\frac{CT}{DT} = \frac{kACt}{2q_o \rho_s S \left(\frac{D_e t}{\pi} \right)^{1/2}}$$

The right-hand side of the above equation can be rearranged to organize the various parameters into convenient groups for analysis as follows:

$$\frac{CT}{DT} = \overset{\text{I}}{\left(\frac{\pi^{1/2}}{2} \right)} \overset{\text{II}}{\left(\frac{A}{S} \right)} \overset{\text{III}}{\left(\frac{C}{q_o \rho_s} \right)} \overset{\text{IV}}{\left(\frac{k}{D_e^{1/2}} t^{1/5} \right)}$$

Group I evaluates to 0.886 and is dimensionless. Group II is also dimensionless and, for practical field geometries, will be less than 0.5. For convenience, Groups I and II can be combined and assigned the value of 0.4 without significantly affecting the outcome of the following analysis.

128. Group III is an important group. It is the ratio of dissolved contaminant concentration to the total contaminant mass initially present in the monolith. The larger C , the more important convective transport; the larger q_o , the more important diffusive transport. The value of C is not independent of q_o , and generally the higher q_o , the higher C . Chemical stabilization, thus, can minimize convective transport by minimizing C . Values for C and q_o are available in Appendix B. The bulk density, ρ_s , can be estimated without serious error and generally ranges from 1,100 to 1,500 kg/m³. For purposes of this analysis, ρ_s was assigned the value of 1,200 kg/m³.

129. Group IV is also an important group. This group is an index of the relative tendency for transport by convection and diffusion. Hydraulic conductivities for solidified/stabilized hazardous waste range from 10⁻⁶ to 10⁻⁹ m/sec (Bartos and Palermo 1976), and solidified/stabilized sediment hydraulic conductivities have been measured in the range of 10⁻⁷ to 10⁻⁸ m/sec (Environmental Laboratory 1987). Effective diffusivity is an intrinsic property of the solidified/stabilized material that must be determined individually for each contaminant of interest. The diffusion coefficient is termed "effective" because it includes sorption. Thus, D_e values for organics such as PCBs are expected to be lower than for highly soluble metals such as

copper. Values for D_e range from 10^{-13} to 10^{-20} m^2/sec (Coté and Isabel 1984). The value reported by Coté and Isabel (1984) for highly soluble sodium was approximately 10^{-13} m^2/sec , and the value for phenol, the only organic tested, was approximately 10^{-16} m^2/sec .

130. Table 23 presents selected combinations of the parameter values discussed above and the resulting CT/DT ratios for Aroclor 1242 and copper. Calculations for 10-, 100-, and 1,000-year periods are presented. An assumed D_e of 10^{-16} m^2/sec for Aroclor 1242 (Coté and Isabel's 1984 phenol data) was used with a range of hydraulic conductivities to calculate CT/DT ratios. These calculations were bracketed with calculations for D_e values of 10^{-15} and 10^{-17} m^2/sec . An assumed D_e of 10^{-13} m^2/sec for copper (Cote and Isabel's 1984 sodium data) was used with a range of hydraulic conductivities to calculate CD/DT ratios. These calculations were bracketed with calculations for D_e values of 10^{-12} and 10^{-14} m^2/sec . The C and q_0 in Table 23 are representative of the data in Appendix B for Aroclor 1242 and copper.

131. The calculations shown in Table 23 indicate that hydraulic conductivities of 10^{-10} m/sec or less are needed to yield CT/DT values of 10^{-1} or less for the 100-year period. Thus, if the solidified/stabilized material has a hydraulic conductivity of 10^{-10} m/sec or less, theoretical transport modeling indicates that convective transport by percolation will be relatively unimportant for at least 100 years and that contaminant loss will be diffusion limited. Diffusion is such a slow process that, for all practical purposes, the contaminants have been immobilized. Unfortunately, solidified/stabilized materials with hydraulic conductivities this low are difficult to obtain without special process modifications designed to reduce permeability. It should be realized that the calculations shown in Table 23 do not take into account site-specific factors that reduce the potential for permeation of solidified/stabilized material. For hydraulic conductivities on the order of 10^{-9} m/sec and higher, site-specific factors become more important.

132. For the above analysis to be reliable, the solidified/stabilized monolith should not deteriorate in 100 years. Unconfined compressive strength and resistance to weathering should, therefore, be high. Guidelines for these properties are not presently available for solidified/stabilized materials, but equivalent standards of practice for concrete should be adequate.

Table 23
Ratio of Cumulative Convective to Diffusive Contaminant Transport
for Various Parameter Values

Pollutant	Group III			Group IV			CT/DT					
	C g/m ³	q _o g/kg	C/(q _o ρ _s)	k m/sec	D _e m/sec	k/D _e ^{1/2} l/sec	10 years	100 years	1,000 years			
Aroclor 1242	1.0 E-01	1.0 E+00	8.3 E-05	1.0 E-07	1.0 E-15	3.2 E+00	1.9 E+00	5.9 E+00	1.9 E+01			
			8.3 E-05	1.0 E-08	1.0 E-15	3.2 E-01	1.9 E-01	5.9 E-01	1.9 E+00			
			8.3 E-05	1.0 E-09	1.0 E-15	3.2 E-02	1.9 E-02	5.9 E-02	1.9 E-01			
			8.3 E-05	1.0 E-10	1.0 E-15	3.2 E-03	1.9 E-03	5.9 E-03	1.9 E-02			
			8.3 E-05	1.0 E-11	1.0 E-15	3.2 E-04	1.9 E-04	5.9 E-04	1.9 E-03			
			8.3 E-05	1.0 E-07	1.0 E-16	1.0 E+01	5.9 E+00	1.9 E+01	5.9 E+01			
			8.3 E-05	1.0 E-08	1.0 E-16	1.0 E+00	5.9 E-01	1.9 E+00	5.9 E+00			
			8.3 E-05	1.0 E-09	1.0 E-16	1.0 E-01	5.9 E-02	1.9 E-01	5.9 E-01			
			8.3 E-05	1.0 E-10	1.0 E-16	1.0 E-02	5.9 E-03	1.9 E-02	5.9 E-02			
			8.3 E-05	1.0 E-11	1.0 E-16	1.0 E-03	5.9 E-04	1.9 E-03	5.9 E-03			
			8.3 E-05	1.0 E-07	1.0 E-17	3.2 E+01	1.9 E+01	5.9 E+01	1.9 E+02			
			8.3 E-05	1.0 E-08	1.0 E-17	3.2 E+00	1.9 E+00	5.9 E+00	1.9 E+01			
			8.3 E-05	1.0 E-09	1.0 E-17	3.2 E-01	1.9 E-01	5.9 E-01	1.9 E+00			
			8.3 E-05	1.0 E-10	1.0 E-17	3.2 E-02	1.9 E-02	5.9 E-02	1.9 E-01			
			8.3 E-05	1.0 E-11	1.0 E-17	3.2 E-03	1.9 E-03	5.9 E-03	1.9 E-02			
			Copper	1.0 E+01	8.0 E-01	1.0 E-02	1.0 E-07	1.0 E-12	1.0 E-01	7.4 E+00	2.3 E+01	7.4 E+01
						1.0 E-02	1.0 E-08	1.0 E-12	1.0 E-02	7.4 E-01	2.3 E+00	7.4 E+00
						1.0 E-02	1.0 E-09	1.0 E-12	1.0 E-03	7.4 E-02	2.3 E-01	7.4 E-01
						1.0 E-02	1.0 E-10	1.0 E-12	1.0 E-04	7.4 E-03	2.3 E-02	7.4 E-02
						1.0 E-02	1.0 E-11	1.0 E-12	1.0 E-05	7.4 E-04	2.3 E-03	7.4 E-03
1.0 E-02	1.0 E-07	1.0 E-13				3.2 E-01	2.3 E+01	7.4 E+01	2.3 E+02			
1.0 E-02	1.0 E-08	1.0 E-13				3.2 E-02	2.3 E+00	7.4 E+00	2.3 E+01			
1.0 E-02	1.0 E-09	1.0 E-13				3.2 E-03	2.3 E-01	7.4 E-01	2.3 E+00			
1.0 E-02	1.0 E-10	1.0 E-13				3.2 E-04	2.3 E-02	7.4 E-02	2.3 E-01			
1.0 E-02	1.0 E-11	1.0 E-13				3.2 E-05	2.3 E-03	7.4 E-03	2.3 E-02			
1.0 E-02	1.0 E-07	1.0 E-14				1.0 E+00	7.4 E+01	2.3 E+02	7.4 E+02			
1.0 E-02	1.0 E-08	1.0 E-14				1.0 E-01	7.4 E+00	2.3 E+01	7.4 E+01			
1.0 E-02	1.0 E-09	1.0 E-14				1.0 E-02	7.4 E-01	2.3 E+00	7.4 E+00			
1.0 E-02	1.0 E-10	1.0 E-14				1.0 E-03	7.4 E-02	2.3 E-01	7.4 E-01			
1.0 E-02	1.0 E-11	1.0 E-14				1.0 E-04	7.4 E-03	2.3 E-02	7.4 E-02			

Note: ρ_s = 1,200 kg/m³.

(Group I) * (Group II) = 0.4.

PART VI: POTENTIAL IMPLEMENTATION SCENARIOS

Design Concepts

133. Solidification/stabilization technology can potentially be implemented in a variety of ways, depending on the design of the disposal facility and the manner in which the setting agents are added to and mixed with the dredged material (Francingues 1984). Two design concepts for disposal of the contaminated dredged material in an upland site are illustrated in Figures 29 and 30. Other designs and mixing concepts or modifications of those presented below may also be feasible.

134. The layered concept shown in Figure 29 involves alternating layers of clean dredged material and contaminated dredged material that has been solidified/stabilized. The initial lift of clean dredged material would be dewatered to promote densification and consolidation to provide a low permeability foundation. Once this layer has achieved the desired degree of consolidation, the solidified/stabilized dredged material would be placed on top. Conventional earthmoving equipment would be used for shaping as necessary before the solidified/stabilized material hardened.

135. One alternative to the layered design for a confined disposal facility is the liner concept. The liner concept incorporates S/S as a treatment to produce a low-permeability foundation. A layer of solidified/stabilized dredged material is initially placed in the site; then, contaminated dredged material is disposed and dewatered. A clean layer of dredged material is used as final cover.

136. The secure disposal concept shown in Figure 30 provides the highest degree of environmental protection. A soil or flexible membrane liner, or both, is used to line the bottom and sides of the disposal site. A coarse-grain layer is used for leachate collection. Contaminated dredged material that has been solidified/stabilized is then placed into the prepared site so that a monolithic block develops as the material cures.

137. As an alternative to the secure facility, the liner and coarse-grain layer could be deleted from the disposal site design if the permeability and leachability of the solidified/stabilized dredged material are sufficiently low. Laboratory permeabilities in the range of 10^{-6} to 10^{-9} m/sec have been achieved with solidification/stabilization of industrial waste

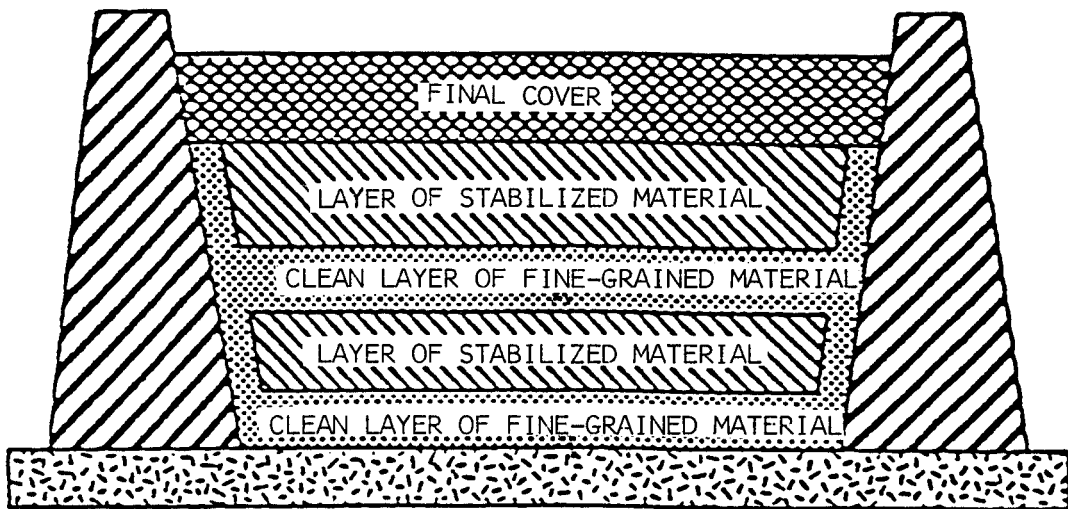

Figure 29. Disposal concept for alternating layers of solidified/stabilized dredged material

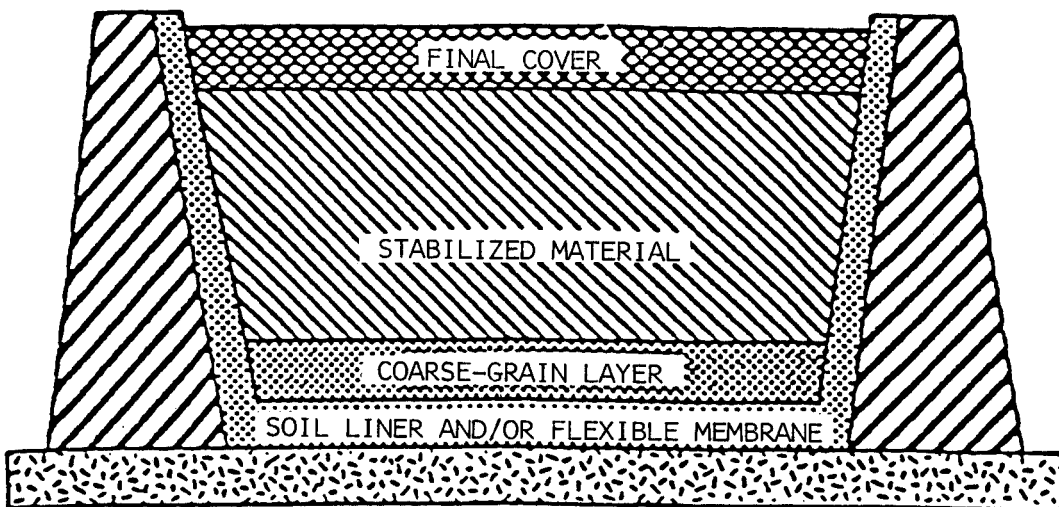

Figure 30. Disposal concept for a monolith of solidified/stabilized dredged material in a secure facility

(Bartos and Palermo 1977). Soils with laboratory permeabilities of 10^{-9} cm/sec or less are usually considered adequate for liner construction.

138. Three basic methods of agent addition and mixing are considered feasible (Francingues 1984). These are in situ mixing, plant mixing, and area mixing.

139. In situ mixing is suitable for dredged materials that have been initially dewatered and is most applicable for addition of large volumes of low-reactivity setting agents. This method incorporates the use of conventional machinery, such as a backhoe, to accomplish the mixing process. Where large containment areas are being treated, clamshells and/or draglines may be used. An alternative to backhoes, clamshells, and draglines involves agent addition and mixing by injection. Specially designed equipment is commercially available that injects and mixes setting agents with the materials to be solidified/stabilized. The system moves laterally along the perimeter of a facility, solidifying the material within the reach of the injection boom. As soon as one pass is completed and the material has set long enough to support the injection carrier, the process is repeated. The equipment advances from solidified/stabilized material to untreated material until the job is complete.

140. Plant mixing is most suitable for application at sites with relatively large quantities of contaminated material to be treated. In the plant mixing process, the dredged material is mechanically mixed with the setting agent(s) in a processing facility prior to disposal. If the volume of material processed does not justify the expense of a mixing plant, one alternative is to mix the setting agent(s) with dredged material in a scow before it is unloaded. Mixing may be accomplished in route to a docking site, as shown in Figure 31, using a specially designed system mounted on the scow for this purpose or by using a shore-based injection system, as shown in Figure 32. In the latter, track-mounted injection equipment would move along the dock and reach all parts of the scow. Solidifying agent in a dry state is piped directly from a tank truck to the injector. Since the setting process takes several days before freshly prepared solidified/stabilized dredged material is hardened and cannot be rehandled, the risk of having the material set up before it can be removed from the scow is minimal. This alternative is not applicable to waterways with shallow water depths, such as in the upper estuary.

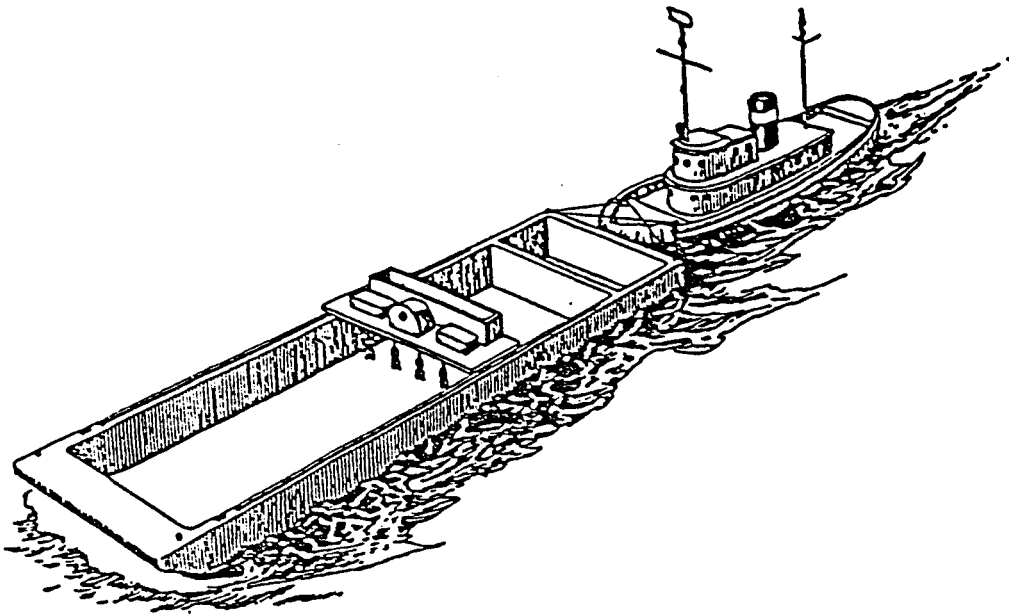

Figure 31. Conceptual sketch of scow fitted with mechanism for mixing setting agents with dredged material

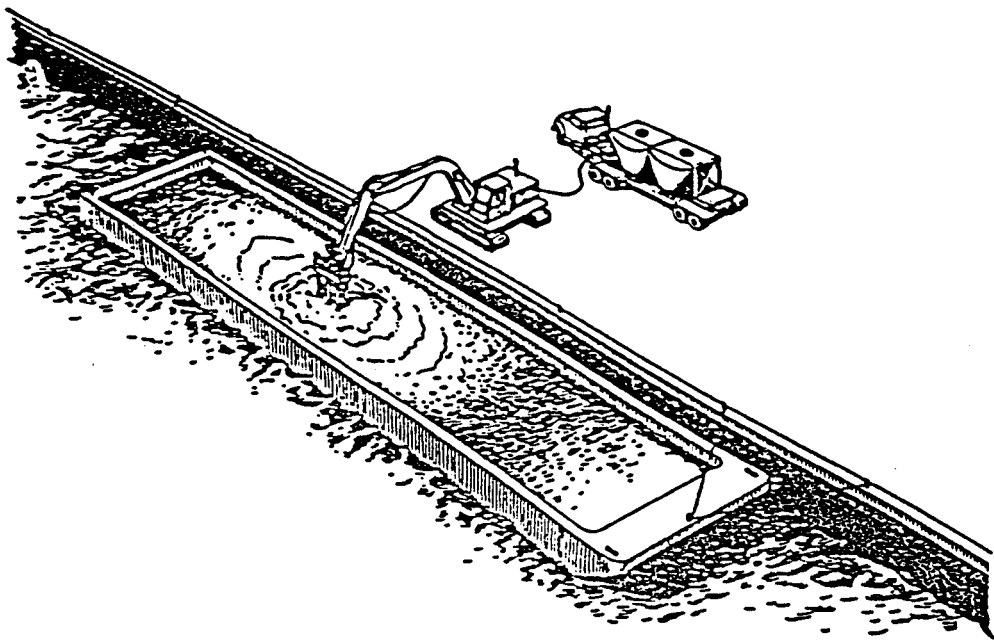

Figure 32. Conceptual sketch of shore-based mixing alternative

141. Area-wide mixing is applicable to those confined disposal sites where high-solids content slurries must be treated. Area-wide mixing involves the use of agricultural-type spreaders and tillers to add and mix setting agent(s) with dredged material. Area-wide mixing is land intensive and presents the greatest possibility for fugitive dust, organic vapor, and odor generation. Implementation of the area-wide mixing concept will require that the dredged material be sufficiently dewatered to support construction equipment.

Cost

142. Actual project cost figures are not available for S/S of dredged material. Application of the technology to hazardous waste is estimated to cost \$30 to \$50 per ton (Cullinane 1985). Actual cost will vary with the amount of setting agent(s) required. The amount of setting agent(s) required depends on the implementation strategy and the performance criteria that are specified. Cost estimates must also take into consideration the volume increase due to the addition of setting agent(s) and future expenditures needed for end-uses anticipated at the site. The cost-effectiveness of solidification/stabilization technology as an alternative to liners and leachate collection and treatment systems or other ground-water pollution control strategies for upland disposal sites depends on the site-specific environmental constraints that are placed on disposal.

PART VII: SUMMARY AND CONCLUSIONS

143. A bench-scale study of solidification/stabilization technology was conducted on two sediment types from the New Bedford Harbor Superfund Site, Massachusetts. Sediment samples were solidified/stabilized with three processes: portland cement, portland cement with Firmix proprietary additive, and Silicate Technology Corporation proprietary additive. The feasibility of eliminating or substantially reducing the pollutant potential of sediments from the New Bedford Harbor Superfund Site was evaluated on the basis of data from physical and chemical tests.

Physical Stabilization

144. Unconfined compressive strength data showed that New Bedford Harbor sediment can be converted to a hardened mass. The range in 28-day unconfined compressive strength was 20 to 481 psi (0.14 to 3.3 MPa). This range in product strength is indicative of the versatility of solidification as a physical stabilization process for contaminated sediment.

Chemical Stabilization

145. Batch leach tests showed that the chemical stabilization properties of the three processes were very similar. The leachability of some contaminants was significantly reduced. However, complete chemical stabilization of all contaminants in sediment from the New Bedford Harbor Superfund Site was not achieved. The leachability of cadmium and zinc was eliminated or substantially reduced. The release of polychlorinated biphenyls during leach testing was reduced by factors of 10 to 100. Copper and nickel were mobilized; that is, the release of copper and nickel during leach testing was greater for solidified/stabilized sediment than for untreated sediment.

146. The unusual leaching characteristics of the untreated sediment made it difficult to use desorption models to quantitatively compare contaminant release from untreated and solidified/stabilized sediment for an infinite number of batch leaching steps. Certain important results, however, were obtained. Desorption isotherm analysis showed that the interphase transfer processes governing contaminant leaching from New Bedford Harbor sediment were

substantially altered by solidification/stabilization processing. The release of PCBs was converted from a desorption process in which leachate PCB concentrations increased during sequential batch leach tests to a desorption process in which the concentrations tended to be constant. Although copper and nickel releases were higher for solidified/stabilized sediment than for untreated sediment, the release of these metals was converted from a desorption process in which leachate copper and nickel concentrations increased during sequential batch leach tests to a desorption process in which concentrations decreased. Thus, the releases of copper, nickel, and PCBs from solidified/stabilized sediment during sequential leaching could be modeled, whereas the releases from untreated sediment could not be modeled.

Contaminant Immobilization

147. Since chemical stabilization by solidification/stabilization processing was not 100-percent effective, physical stabilization of contaminants by reduced accessibility of water is important for effective contaminant immobilization. Conversion from a plastic state to a solid monolith should reduce the accessibility of water to the contaminated solids. Theoretical transport modeling indicated that contaminant transport by water percolating through solidified/stabilized dredged material with chemical stabilization properties similar to those reported here will be relatively unimportant for solidified/stabilized material with a hydraulic conductivity of 10^{-10} m/sec. Higher hydraulic conductivities will require better chemical stabilization to provide equivalent immobilization against percolation. Thus, contaminant leaching by percolating water can be controlled by careful selection of physical and chemical properties for the solidified/stabilized product.

REFERENCES

- Ballinger, D. C. 1979. "Methods for Chemical Analysis of Water and Wastes," EPA/600/4-79/020, Environmental Monitoring and Support Laboratory, Cincinnati, OH.
- Bartos, M. J., and Palermo, M. R. 1977. "Physical and Engineering Properties of Hazardous Industrial Waste Sludges," EPA/600/2-77/139, US Environmental Protection Agency, Cincinnati, OH.
- Brannon, J. M., Engler, R. M., Rose, J. R., Hunt, P. G., and Smith, I. 1976. "Selective Analytical Partitioning of Sediments to Evaluate Potential Mobility of Chemical Constituents During Dredging and Disposal Operations," Technical Report D-76-7, US Army Engineer Waterways Experiment Station, Vicksburg, MS.
- Brannon, J. M., Plumb, R. H., Jr., and Smith, I. 1980. "Long-Term Release of Heavy Metals from Sediments," Contaminants in Sediments, R. A. Baker, ed., Ann Arbor Science, Ann Arbor, MI.
- Coté, P. L., and Isabel, D. 1984. "Application of a Dynamic Leaching Test to Solidified Hazardous Wastes," Hazardous and Industrial Waste Management and Testing, Third Symposium, ASTM STP 851, American Society for Testing and Materials, Philadelphia, PA.
- Cullinane, M. J. 1985. "Field Scale Solidification/Stabilization of Hazardous Wastes," paper presented at the National Conference on Environmental Engineering, American Society of Civil Engineers, July 1-3, 1985, Boston, MA.
- Cullinane, M. J., Jr., Jones, L. W., and Malone, P. G. 1986. "Handbook for Stabilization/Solidification of Hazardous Waste," US Environmental Protection Agency, EPA/540/2-86/001, Cincinnati, OH.
- Dexter, R. N., and Pavlou, S. P. 1978. "Mass Solubility and Aqueous Activity Coefficients of Stable Organic Chemicals in the Marine Environment: Polychlorinated Biphenyls," Marine Chemistry, Vol 6, pp 41-53.
- Di Toro, D. M., and Horzempa, L. M. 1982. "Reversible and Resistant Components of PCB Adsorption-Desorption: Isotherms," Environmental Science and Technology, Vol 16, No. 9, pp 594-602.
- Di Toro, D. M., Mahony, J. D., Kirchgraber, P. R., O'Byrne, A. L., Pasquale, L. R., and Piccirilli, D. C. 1986. "Effects of Nonreversibility, Particle Concentration, and Ionic Strength on Heavy-Metal Sorption," Environmental Science and Technology, Vol 20, No. 1, pp 55-61.
- Environmental Laboratory. 1987. "Disposal Alternatives for PCB-Contaminated Sediments from Indiana Harbor, Indiana; Vol II," Miscellaneous Paper EL-87-9, US Army Engineer Waterways Experiment Station, Vicksburg, MS.
- Francingues, N. R., Jr. 1984. "Identification of Promising Concepts for Treatment of Contaminated Sediments," Proceedings of the 10th US/Japan Experts Meeting, Management of Bottom Sediments Containing Toxic Substances, US Army Engineer Water Resources Support Center, Fort Belvoir, VA.
- Godbee, H. W., and Joy, D. S. 1974. "Assessment of the Loss of Radioactive Isotopes from Waste Solids to the Environment; Part I: Background and Theory," TM-4333, Oak Ridge National Laboratory, Oak Ridge, TN.

- Gschwend, P. M., and Wu, S. 1985. "On the Constancy of Sediment-Water Partition Coefficients of Hydrophobic Organic Pollutants," Environmental Science and Technology, Vol 19, No. 1, pp 90-96.
- Jones, J. N., Bricka, R. M., Myers, T. E., and Thompson, D. W. 1985. "Factors Affecting Stabilization/Solidification of Hazardous Waste," Proceedings of the Eleventh Annual Research Symposium on Land Disposal of Hazardous Waste, EPA/600/9-85/013, US Environmental Protection Agency, Cincinnati, OH.
- Jones, R. A., and Lee, G. F. 1978. "Evaluation of the Elutriate Test as a Method of Predicting Contaminant Release During Open-Water Disposal of Dredged Sediments and Environmental Impact of Open-Water Dredged Material Disposal; Volume I: Discussion," Technical Report D-78-45, US Army Engineer Waterways Experiment Station, Vicksburg, MS.
- Kita, D., and Kubo, H. 1983. "Several Solidified Sediment Examples," Proceedings of the Ninth Annual US/Japan Experts Meeting, Management of Bottom Sediments Containing Toxic Substances, US Army Engineer Water Resources Support Center, Fort Belvoir, VA.
- Lee, G. F., Jones, R. A., Saleh, F. Y., Mariani, G. M., Momer, D. H., Butler, J. S., and Bandyopadhyay, P. 1978. "Evaluation of the Elutriate Test as a Method of Predicting Contaminant Release During Open-Water Disposal of Dredged Sediments and Environmental Impact of Open-Water Dredged Material Disposal; Volume II: Data Report," Technical Report D-78-45, US Army Engineer Waterways Experiment Station, Vicksburg, MS.
- Lowenbach, W. 1978. "Compilation and Evaluation of Leaching Test Methods," EPA/600/2-78/095, US Environmental Protection Agency, Cincinnati, OH.
- Malone, P. G., Jones, L. W., and Larson, R. J. 1980. "Guide to the Disposal of Chemically Stabilized and Solidified Waste," SW-872, US Environmental Protection Agency, Cincinnati, OH.
- Moore, J. G., Godbee, H. W., and Kibbey, A. H. 1976. "Leach Behavior of Hydrofracture Grout Incorporating Radioactive Wastes," Nuclear Technology, Vol 32, pp 39-52.
- Myers, T. E., Brannon, J. M., and Griffin, D. M., Jr. 1986. "An Integrated Laboratory Approach to Investigating Contaminant Leaching from Dredged Material," Paper No. 73b, presented at the Summer National Meeting, American Institute of Chemical Engineers, August 24-27, 1986, Boston, MA.
- Myers, T. E., Francingues, N. R., Jr., Thompson, D. W., and Hill, D. O. 1985. "Sorbent Assisted Solidification," Proceedings: International Conference on New Frontiers for Hazardous Waste Management, EPA/600/9-85/025, US Environmental Protection Agency, Cincinnati, OH.
- Myers, T. E., and Hill, D. O. 1986. "Extrapolation of Leach Test Data to the Field Situation," Journal of the Mississippi Academy of Sciences, Vol 31, pp 27-46.
- Nakamura, M. 1983. "Experiences with the Stabilization of Sediments," Proceedings of the Ninth Annual US/Japan Experts Meeting, Management of Bottom Sediments Containing Toxic Substances, US Army Engineer Water Resources Support Center, Fort Belvoir, VA.

- Nathwani J. S., and Phillips, C. R. 1979. "Rate Controlling Processes in the Release of Radium-226 from Uranium Mill Tailings," Water, Air, and Soil Pollution, Vol 11, pp 309-317.
- NUS Corporation. 1984. "Draft Feasibility Study of Remedial Action Alternatives, Acushnet River Estuary Above Coggeshall Street Bridge, New Bedford Site, Bristol County, Massachusetts," Pittsburgh, PA.
- O'Conner, D. J., and Connolly, J. P. 1980. "The Effect of Concentration of Adsorbing Solids on the Partition Coefficient," Water Research, Vol 14, pp 1517-1523.
- Otsuki, T., and Shima, M. 1982. "Soil Improvement by Deep Cement Continuous Mixing Method and Its Effect on the Environment," Proceedings of the Eighth Annual US/Japan Experts Meeting, Management of Bottom Sediments Containing Toxic Substances, US Army Engineer Water Resources Support Center, Fort Belvoir, VA.
- Palermo, M. R. 1986. "Development of a Modified Elutriate Test for Estimating the Quality of Effluent from Confined Disposal Areas," Technical Report D-86-4, US Army Engineer Waterways Experiment Station, Vicksburg, MS.
- Palermo, M. R., et al. "Evaluation of Dredged Material Disposal Alternatives for US Navy Homeport at Everett, Washington," Technical Report (in preparation), US Army Engineer Waterways Experiment Station, Vicksburg, MS.
- Perket, C. L., and Webster, W. C. 1981. "Literature Review of Batch Laboratory Leaching and Extraction Procedures," Hazardous Solid Waste Testing: First Conference, R. A. Conway and B. C. Malloy, eds., ASTM STP 760, American Society for Testing and Materials, Philadelphia, PA.
- Pojasek, R. B. 1979. Toxic and Hazardous Waste Disposal; Vol I: Processes for Stabilization/Solidification; Vol II: Options for Stabilization/Solidification, Ann Arbor Science, Ann Arbor, MI.
- Schroeder, P. R., Morgan, J. M., Walski, T. M., and Gibson, A. C. 1984. "The Hydrologic Evaluation of Landfill Performance (HELP) Model," EPA/630/SW-84/009, Municipal Environmental Research Laboratory, Cincinnati, OH.
- Tittlebaum, M. E., Seals, R. K., Cartledge, F. K., and Engels, S. 1985. "State of the Art on Stabilization of Hazardous Organic Liquid Wastes and Sludges," CRC Critical Reviews in Environmental Control, Vol 15, No. 2, pp 179-211.
- US Environmental Protection Agency. 1980a. "Guidelines for Specification of Disposal Sites for Dredged or Fill Material," Federal Register, Vol 45, No. 249 (24 Dec), pp 85336-85358.
- _____. 1980b. "Testing Requirements for the Specification of Disposal Sites for Dredged or Filled Material," Federal Register, Vol 45, No. 249 (24 Dec), pp 85359-85367.
- _____. 1981. Federal Register, Vol 46, No. 129 (7 Jul), pp 35246-35249.
- _____. 1986. "Prohibition on the Placement of Bulk Liquid Hazardous Waste in Landfills--Statutory Interpretive Guidance," Office of Solid Waste and Emergency Response Policy Directive No. 9487.00-21, EPA/530/SW-86/016, Washington, DC.

Voice, T. C., Rice, C. P., and Weber, W. J., Jr. 1983. "Effect of Solids Concentration on the Sorptive Partitioning of Hydrophobic Pollutants in Aquatic Systems," Environmental Science and Technology, Vol 17, No. 9, pp 513-518.

Voice, T. C., and Weber, W. J., Jr. 1983. "Sorption of Hydrophobic Compounds by Sediments, Soils and Suspended Solids; I: Theory and Background," Water Research, Vol 17, No. 10, pp 1433-1441.

Weber, W. J., Jr. 1972. Physicochemical Processes for Water Quality Control, Wiley-Interscience, New York.

APPENDIX A: SEQUENTIAL BATCH LEACH DATA FOR HOT-SPOT SEDIMENT,
NEW BEDFORD HARBOR

Table A1

Heavy Metal Concentrations [mg/l (Standard Error)] in Leachate from
Anaerobic New Bedford Sediment (Hot-Spot)

Metal	Sequential Leach Number				
	1	2	3	4	5
Cd	<0.0001(0.000)	0.0003(0.000)	0.007(0.0007)	0.003(0.0002)	0.004(0.0004)
Cr	0.011(0.0003)	0.032(0.003)	0.082(0.028)	0.050(0.002)	0.063(0.002)
Cu	0.010(0.0007)	0.044(0.005)	0.353(0.018)	0.154(0.005)	0.235(0.022)
Pb	0.013(0.002)	0.008(0.001)	0.012(0.0007)	0.004(0.0003)	0.008(0.001)
Ni	0.020(0.013)	0.004(0.011)	0.014(0.0009)	0.011(0.0006)	0.015(0.0009)
Zn	0.150(0.035)	0.098(0.010)	0.605(0.027)	0.301(0.012)	0.450(0.062)

A3

Table A2

Steady-State Heavy Metal Sediment Concentration (mg/kg) in
Anaerobic New Bedford Sediment (Hot-Spot)

Metal	Sequential Leach Number				
	1	2	3	4	5
Cd	36.20	36.20	36.17	36.16	36.14
Cr	544.76	544.63	544.30	544.10	543.85
Cu	1,327.96	1,327.78	1,326.37	1,325.75	1,324.81
Pb	1,010.75	1,010.72	1,010.67	1,010.65	1,010.62
Ni	90.02	90.01	89.95	89.91	89.85
Zn	3,363.40	3,363.01	3,360.59	3,359.39	3,357.59

Table A3

Concentrations of PCBs [mg/L (Standard Error)] in Leachate from Anaerobic New Bedford Sediment (Hot-Spot)

Parameter	Sequential Leach Number				
	1	2	3	4	5
C7*	0.0003(0.00001)	0.0007(0.000009)	0.004(0.001)	0.007(0.0005)	0.005(0.001)
C8	0.073(0.008)	0.207(0.003)	1.60(0.058)	5.20(0.404)	3.90(0.656)
C28	0.065(0.007)	0.223(0.007)	1.80(0.035)	7.20(0.608)	4.71(1.51)
C44	0.023(0.002)	0.079(0.002)	0.603(0.026)	1.73(0.145)	1.31(0.287)
C49	0.006(0.0008)	0.021(0.0003)	0.150(0.025)	0.387(0.029)	0.251(0.084)
C50	0.044(0.004)	0.157(0.003)	1.33(0.088)	5.67(0.463)	3.70(1.20)
C52	0.035(0.005)	0.120(0.000)	0.950(0.029)	2.97(0.233)	2.03(0.567)
C70	0.025(0.002)	0.088(0.002)	0.610(0.111)	1.67(0.120)	1.12(0.380)
C87	0.002(0.0003)	0.038(0.016)	0.037(0.017)	0.105(0.026)	0.089(0.043)
C97	0.012(0.001)	0.040(0.0009)	0.293(0.037)	0.833(0.075)	0.600(0.206)
C101	0.025(0.003)	0.089(0.002)	0.613(0.127)	2.17(0.167)	1.24(0.464)
C118	0.015(0.001)	0.056(0.002)	0.377(0.079)	1.33(0.088)	0.740(0.302)
C136	0.003(0.0004)	0.011(0.0003)	0.098(0.006)	0.360(0.052)	0.281(0.109)
C138	0.005(0.0006)	0.019(0.0003)	0.125(0.035)	0.347(0.022)	0.187(0.070)
C143	0.006(0.0004)	0.024(0.0009)	0.139(0.056)	<0.00001(0.000)	<0.00001(0.000)
C153	0.035(0.005)	0.120(0.000)	0.950(0.029)	2.97(0.233)	2.03(0.567)
C155	0.017(0.0017)	0.060(0.001)	0.430(0.055)	0.980(0.071)	0.677(0.164)
C167	0.001(0.0002)	0.005(0.0002)	0.034(0.015)	0.083(0.005)	0.031(0.015)
C180	0.001(0.00009)	0.005(0.0002)	0.034(0.014)	0.106(0.007)	0.040(0.019)
C185	0.00009(0.000)	<0.00001(0.000)	0.0021(0.000)	0.010(0.0005)	0.003(0.001)
AI242**	0.433(0.029)	1.60(0.000)	15.33(1.87)	47.00(2.52)	31.67(4.33)
AI254	0.293(0.018)	0.886(0.019)	3.83(1.82)	13.33(1.45)	9.17(2.35)
Total PCB	0.660(0.072)	2.283(0.073)	19.33(0.882)	64.33(4.33)	40.33(7.67)

* C = congener; see Table 5 of main text for PCB congener identification key.

** A = Aroclor.

Table A4
 Concentration of PCBs (mg/kg) in Anaerobic New Bedford Sediment (Hot-Spot)

Parameter	Sequential Leach Number				
	1	2	3	4	5
C7	3.081	3.076	3.059	3.032	3.010
C8	687.71	686.88	680.48	659.68	644.08
C28	737.74	736.85	729.65	700.85	681.99
C44	309.91	309.59	307.18	300.24	294.99
C49	232.98	232.89	232.29	230.75	229.74
C50	535.83	535.20	529.87	507.20	492.40
C52	521.86	521.38	517.58	505.71	497.58
C70	198.90	198.55	196.11	189.44	184.96
C87	24.59	24.44	24.29	23.87	23.52
C97	473.95	473.79	472.62	469.29	466.89
C101	423.90	423.55	421.09	412.43	407.47
C118	325.90	325.72	324.21	318.88	315.92
C136	111.99	111.95	111.55	110.11	108.98
C138	148.38	146.31	145.81	144.42	143.67
C143	158.98	158.88	158.33	158.33	158.33
C153	287.97	287.73	286.37	280.71	278.35
C155	107.93	107.69	105.97	102.05	99.34
C167	78.99	78.98	78.84	78.51	78.38
C180	19.00	18.98	18.84	18.41	18.25
C185	48.00	48.00	48.00	48.00	48.00
C1242	5,698.23	5,691.87	5,630.53	5,442.53	5,315.87
C1254	2,698.83	2,695.28	2,679.95	2,626.71	2,589.95
Total PCB	7,677.36	7,668.23	7,590.89	7,333.56	7,172.23

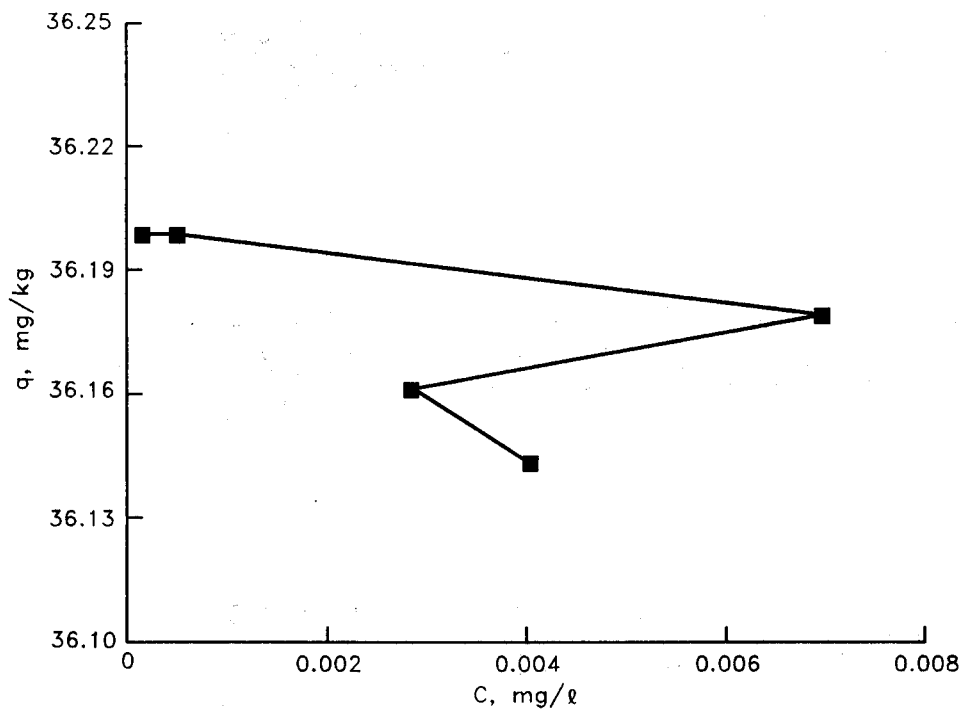

Figure A1. Cadmium desorption isotherm for hot-spot New Bedford Harbor sediment

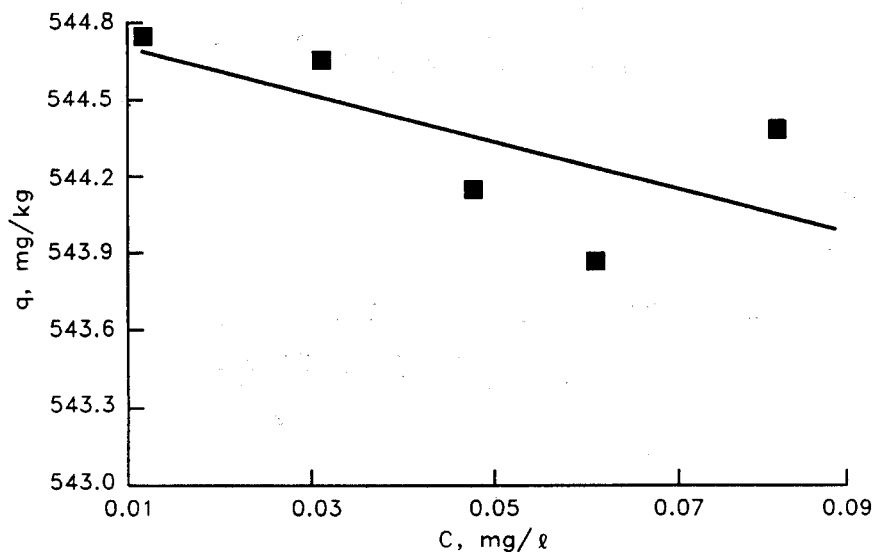

Figure A2. Chromium desorption isotherm for hot-spot New Bedford Harbor sediment

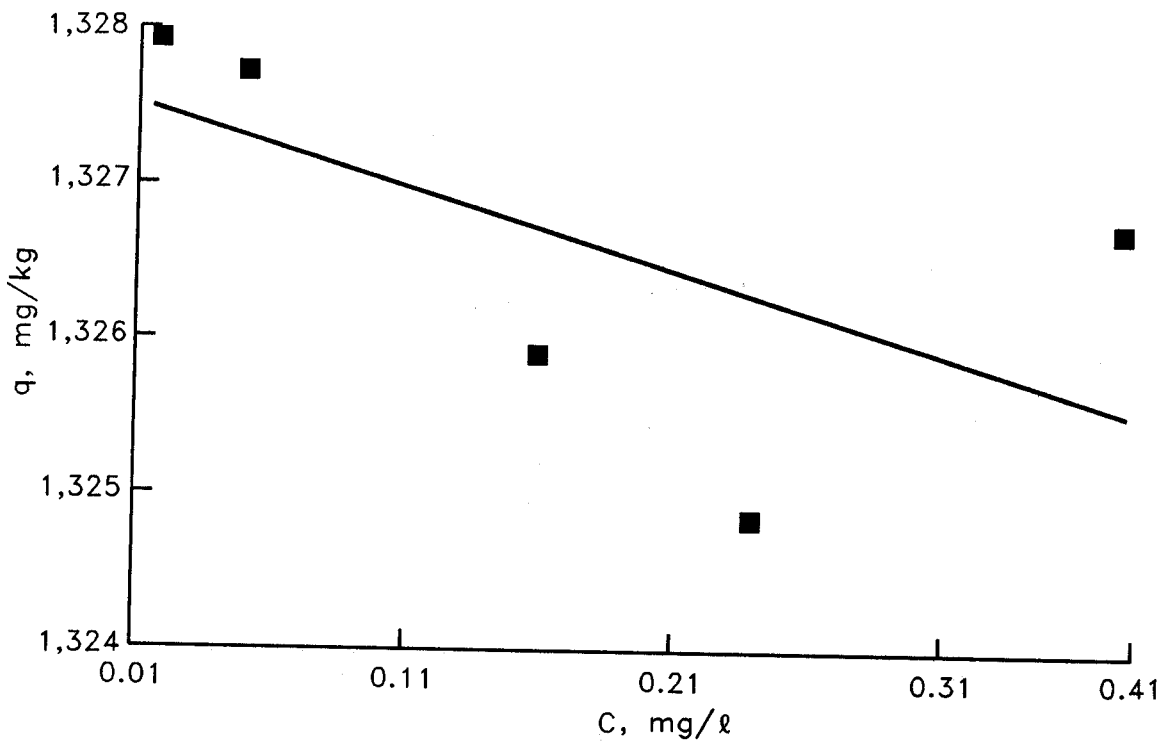

Figure A3. Copper desorption isotherm for hot-spot New Bedford Harbor sediment

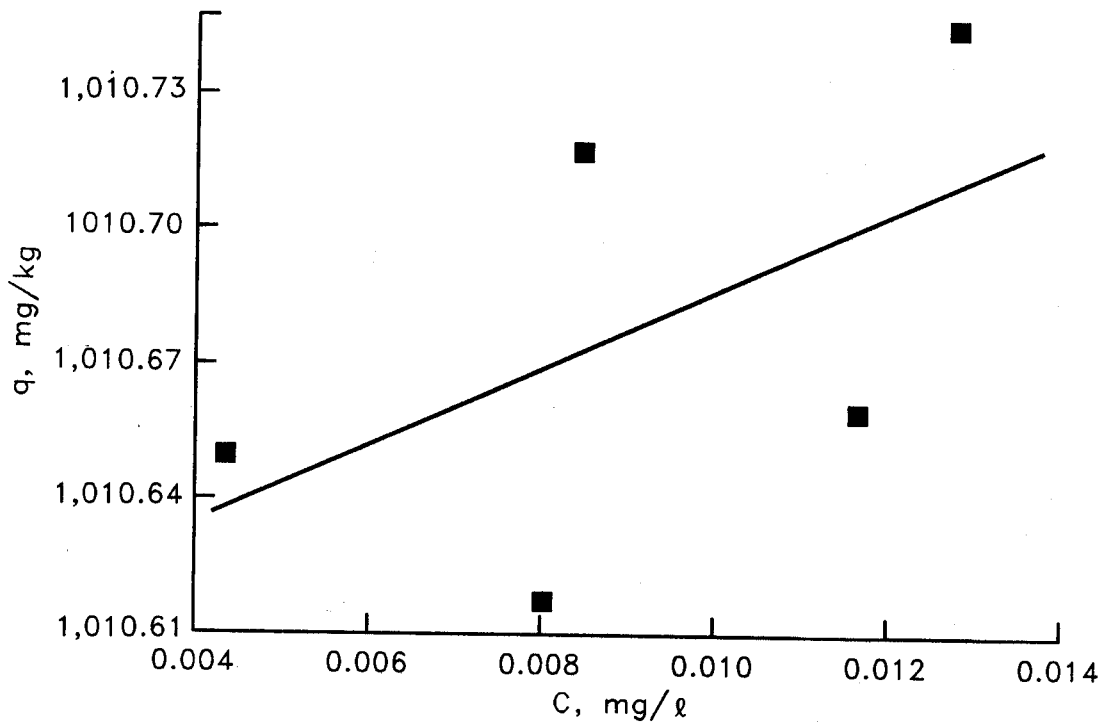

Figure A4. Lead desorption isotherm for hot-spot New Bedford Harbor sediment

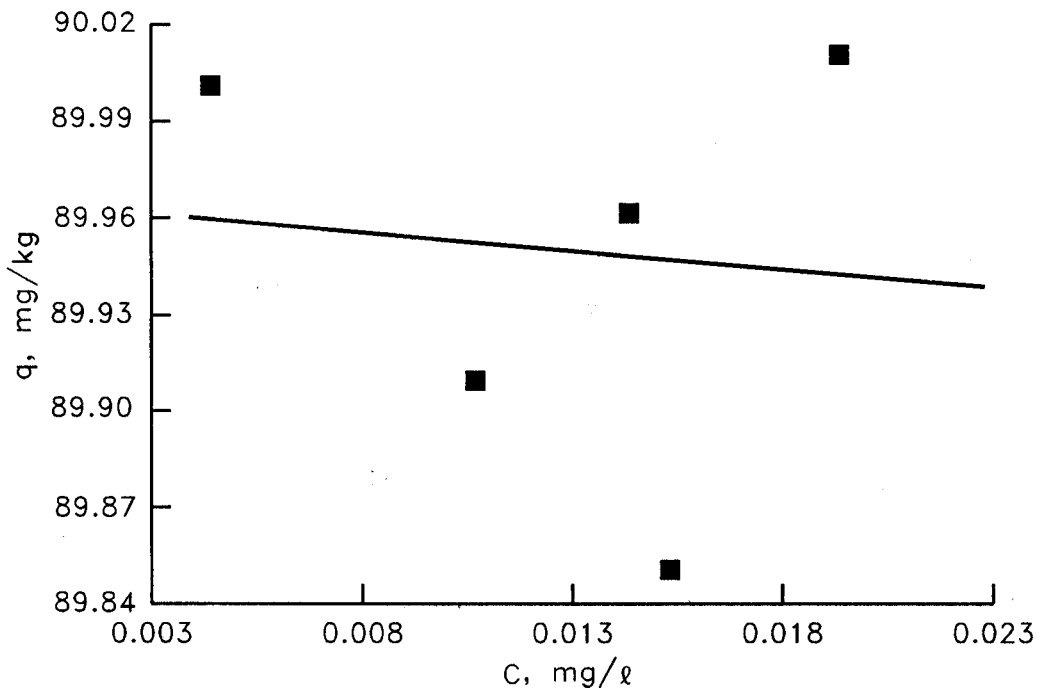

Figure A5. Nickel desorption isotherm for hot-spot New Bedford Harbor sediment

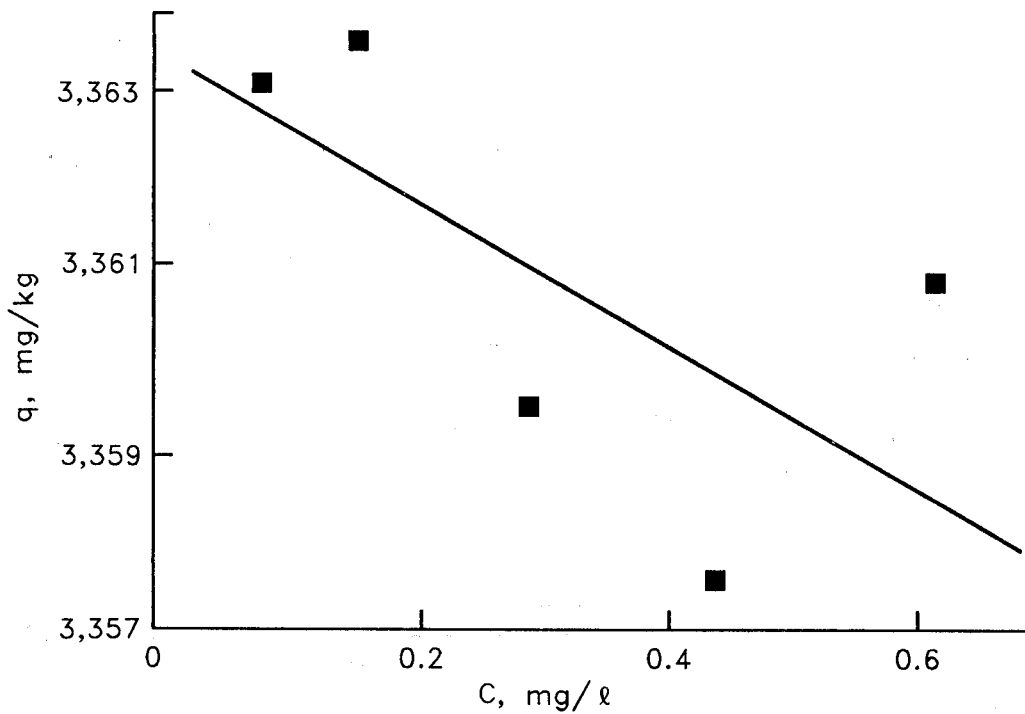

Figure A6. Zinc desorption isotherm for hot-spot New Bedford Harbor sediment

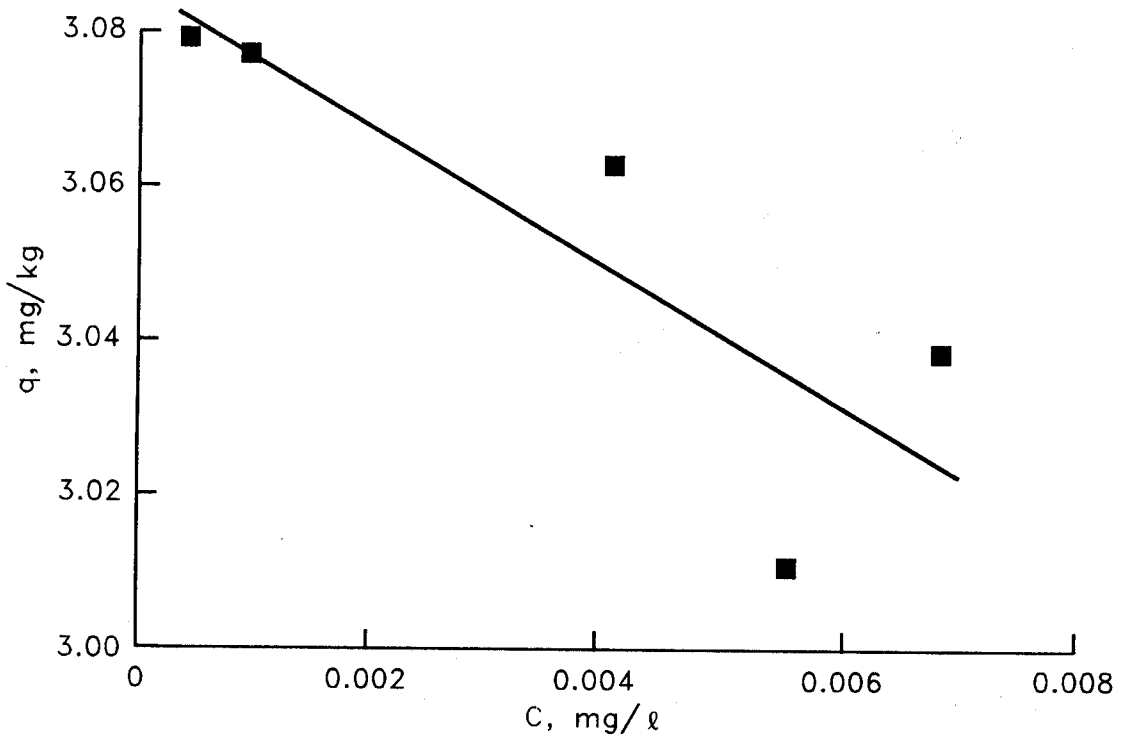

Figure A7. PCB congener C7 desorption isotherm for hot-spot New Bedford Harbor sediment

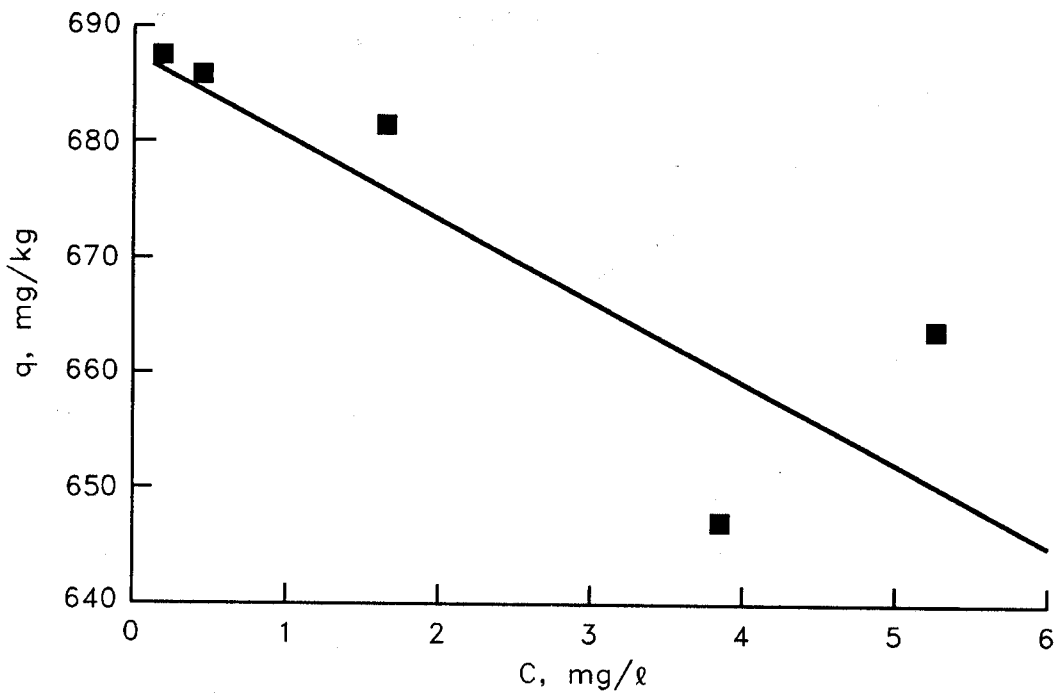

Figure A8. PCB congener C8 desorption isotherm for hot-spot New Bedford Harbor sediment

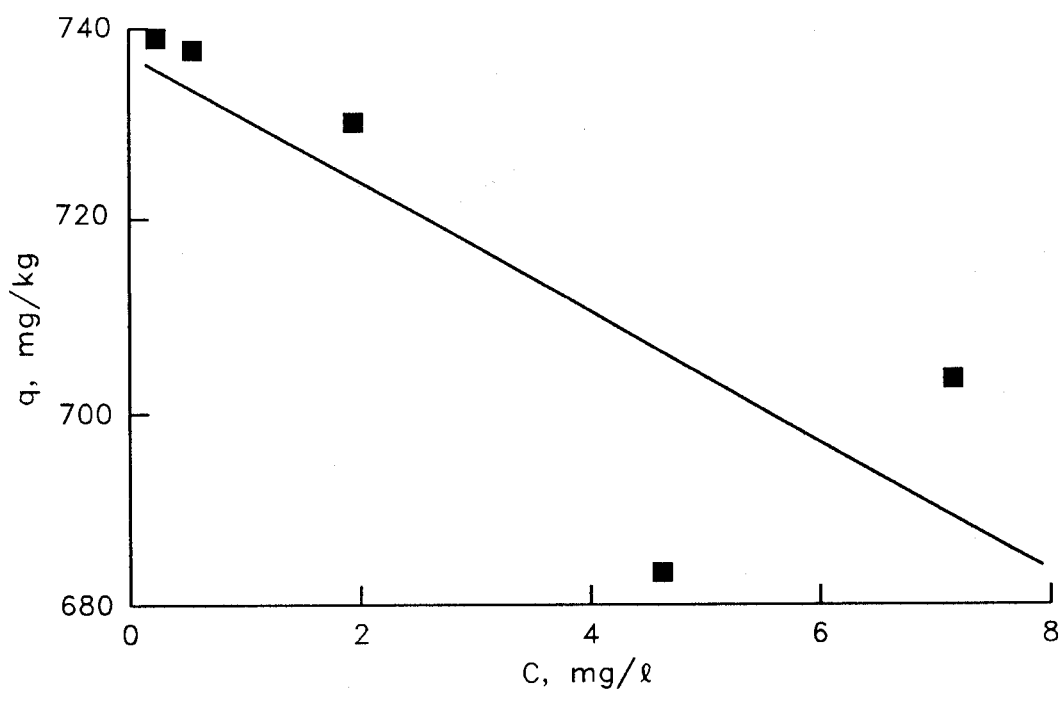

Figure A9. PCB congener C28 desorption isotherm for hot-spot New Bedford Harbor sediment

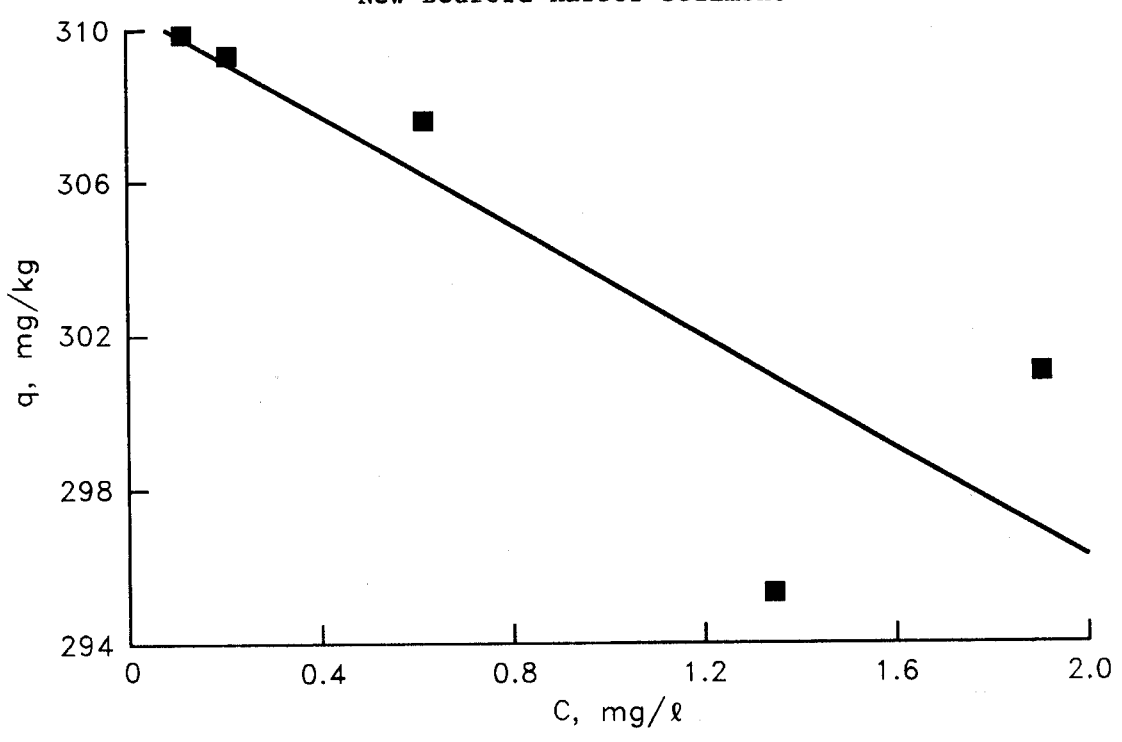

Figure A10. PCB congener C44 desorption isotherm for hot-spot New Bedford Harbor sediment

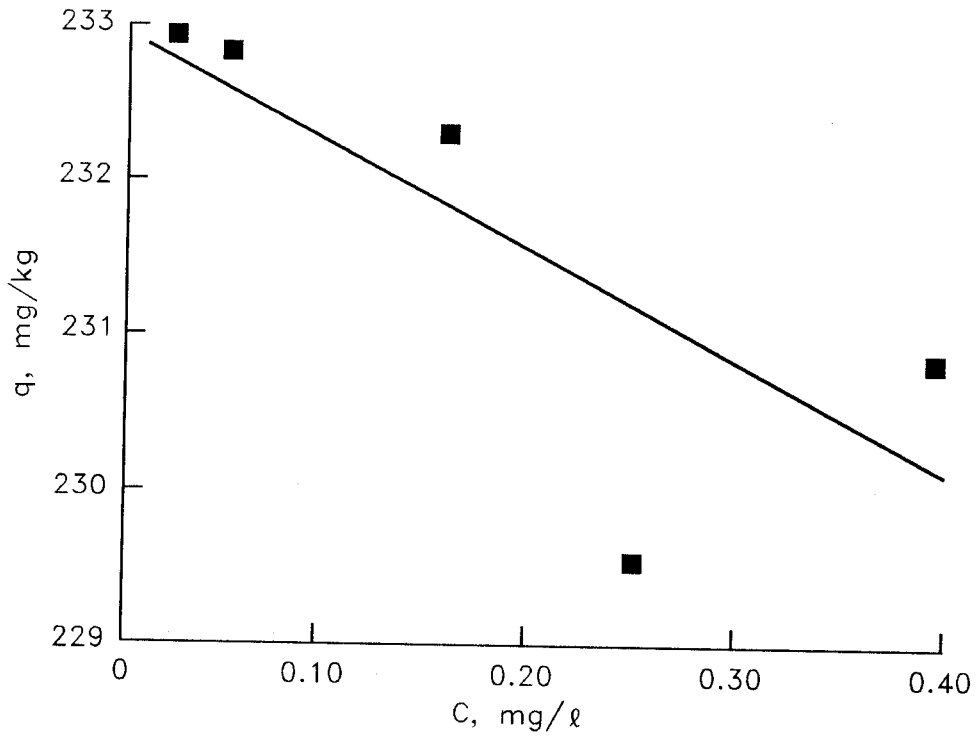

Figure A11. PCB congener C49 desorption isotherm for hot-spot New Bedford Harbor sediment

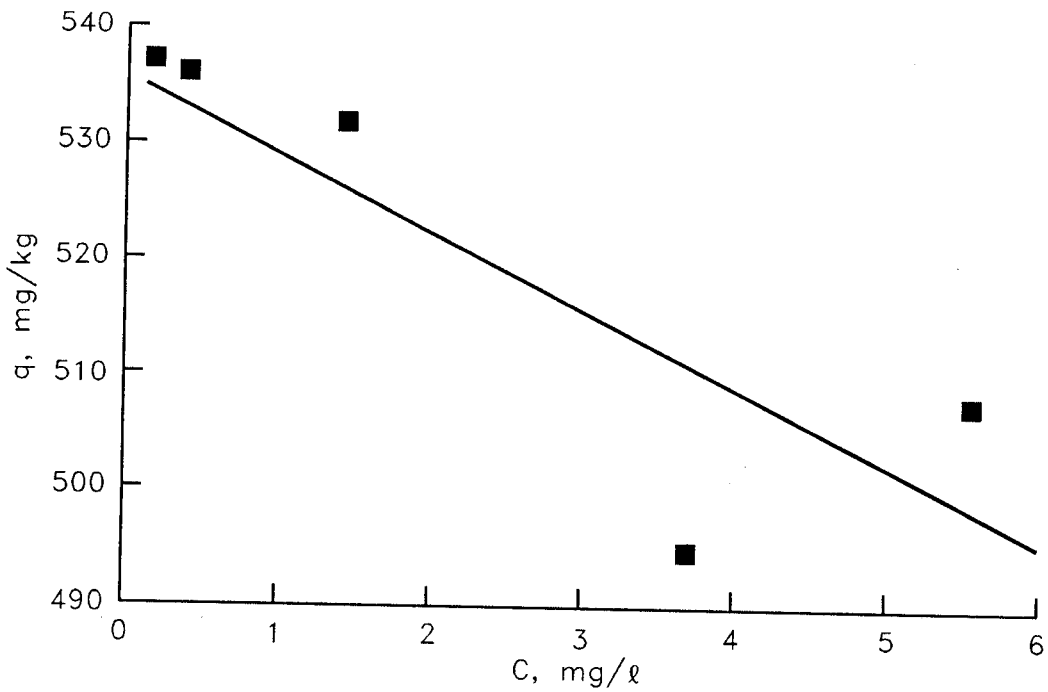

Figure A12. PCB congener C50 desorption isotherm for hot-spot New Bedford Harbor sediment

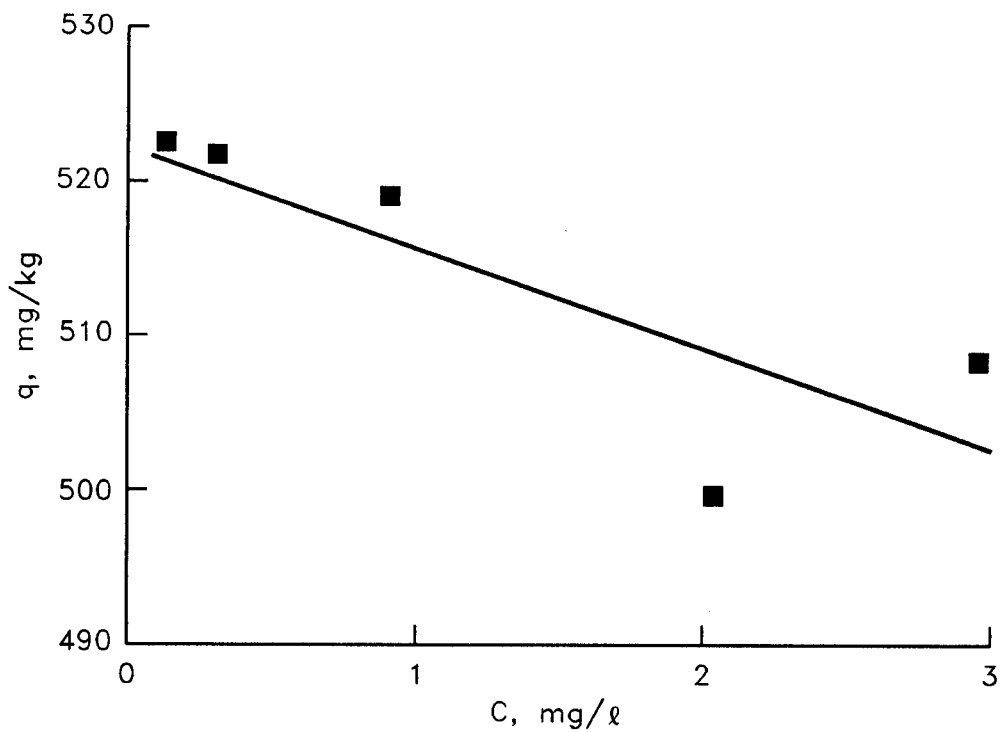

Figure A13. PCB congener C52 desorption isotherm for hot-hot New Bedford Harbor sediment

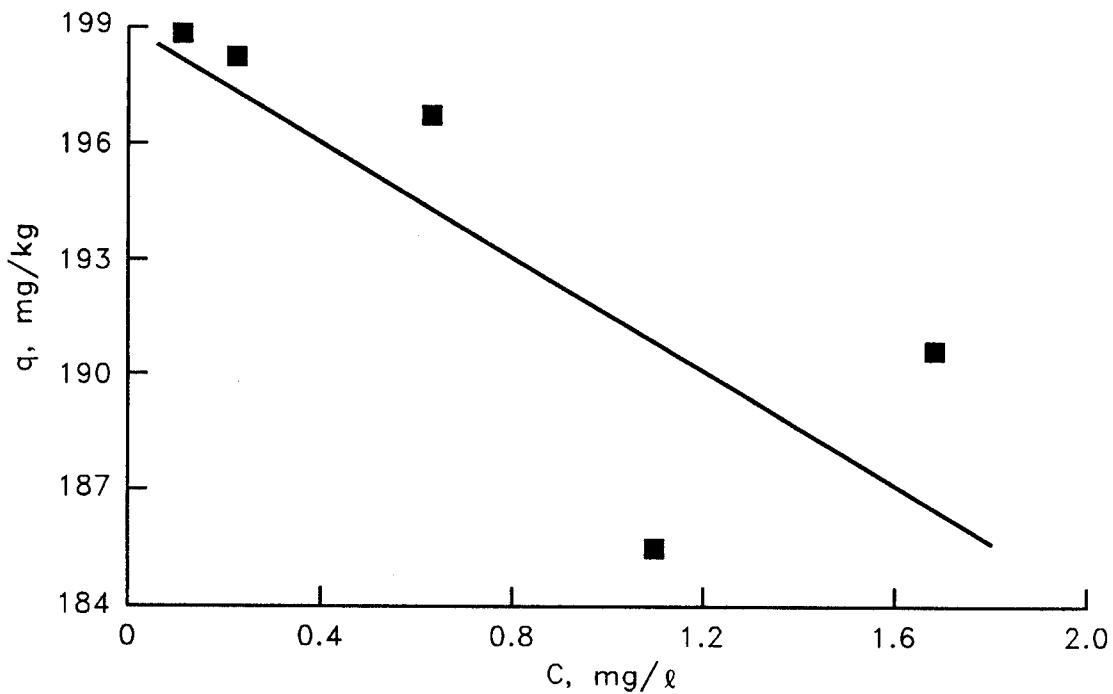

Figure A14. PCB congener C70 desorption isotherm for hot-spot New Bedford Harbor sediment

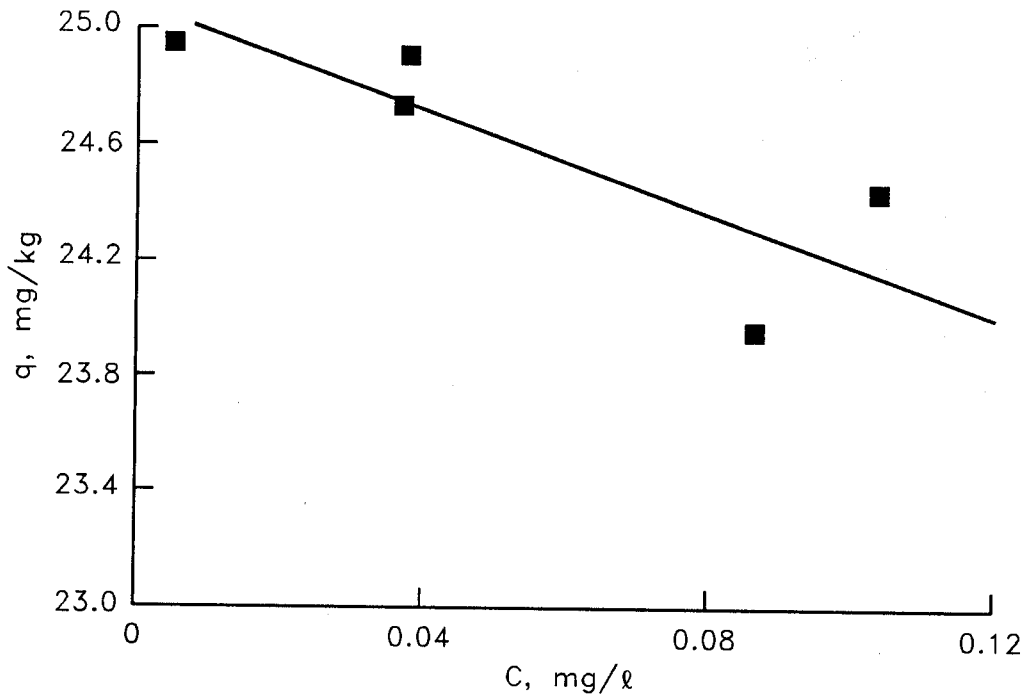

Figure A15. PCB congener C87 desorption isotherm for hot-spot New Bedford Harbor sediment

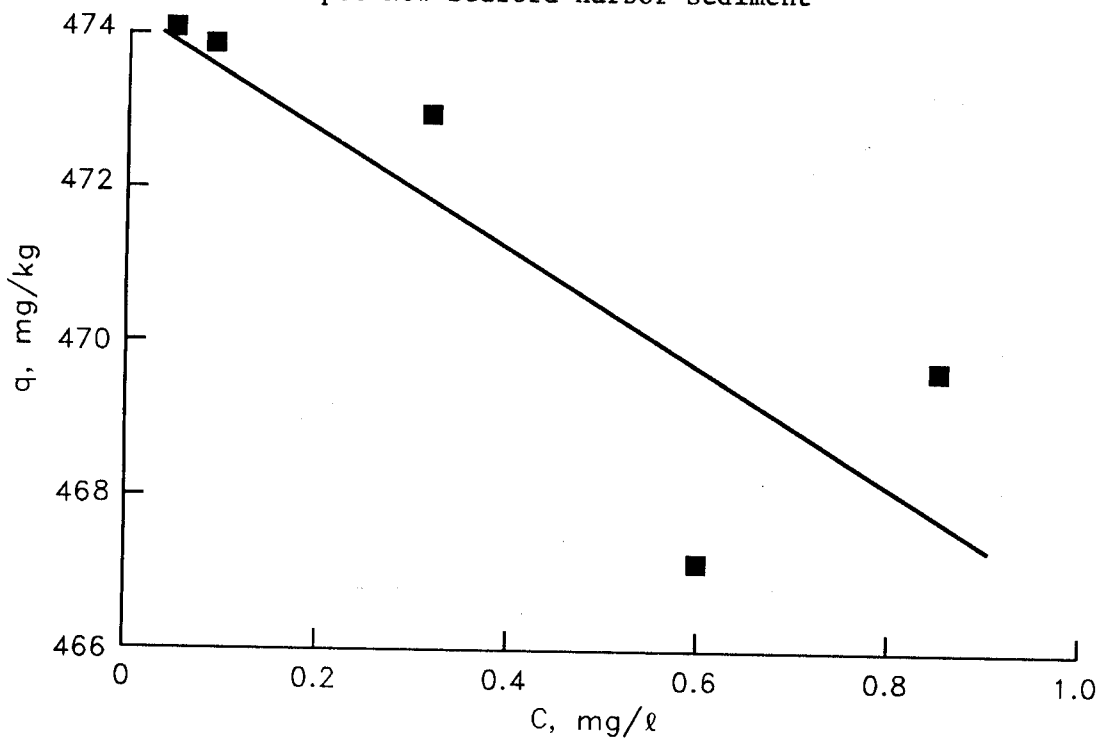

Figure A16. PCB congener C97 desorption isotherm for hot-spot New Bedford Harbor sediment

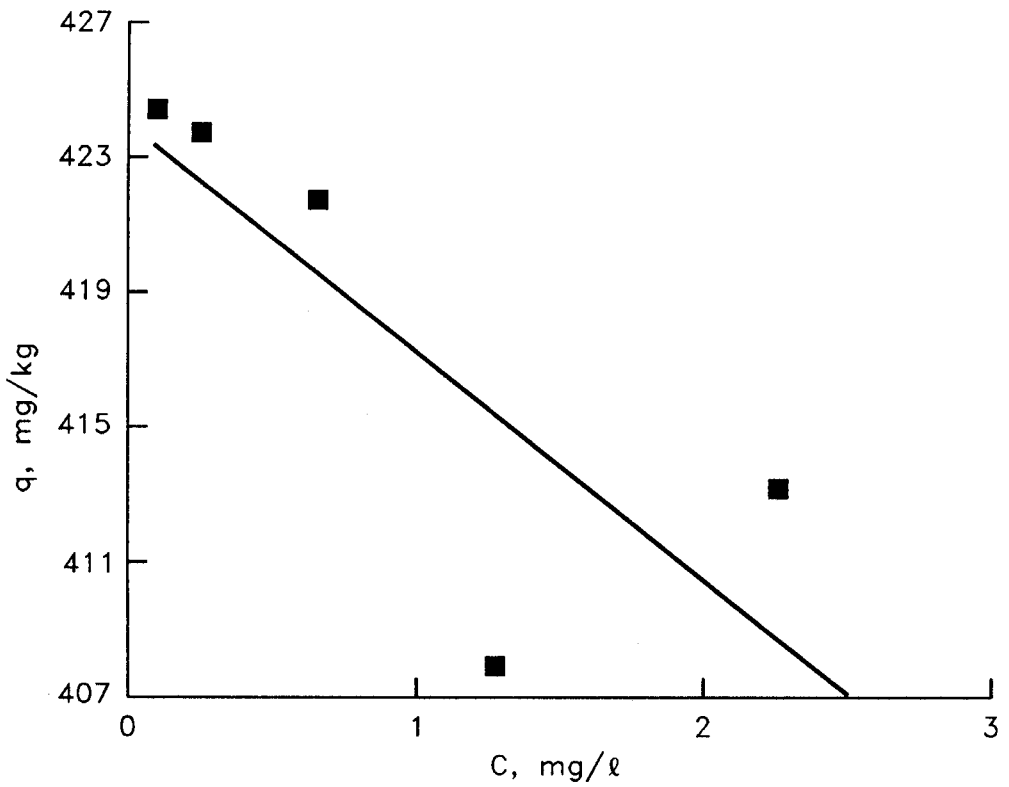

Figure A17. PCB congener C101 desorption isotherm for hot-spot New Bedford Harbor sediment

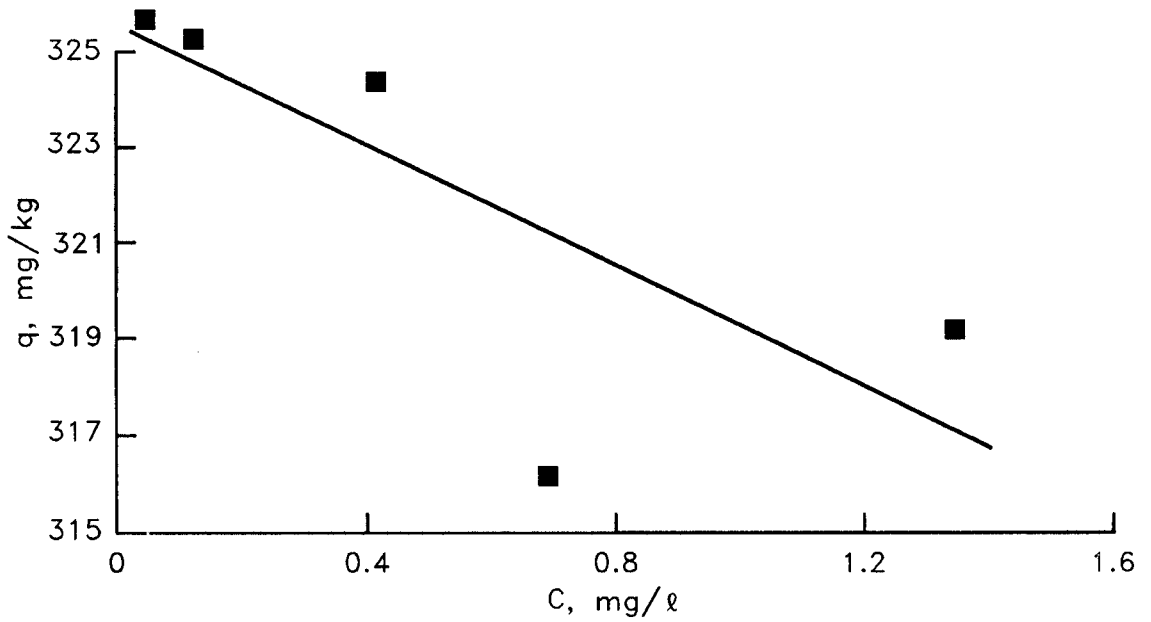

Figure A18. PCB congener C118 desorption isotherm for hot-spot New Bedford Harbor sediment

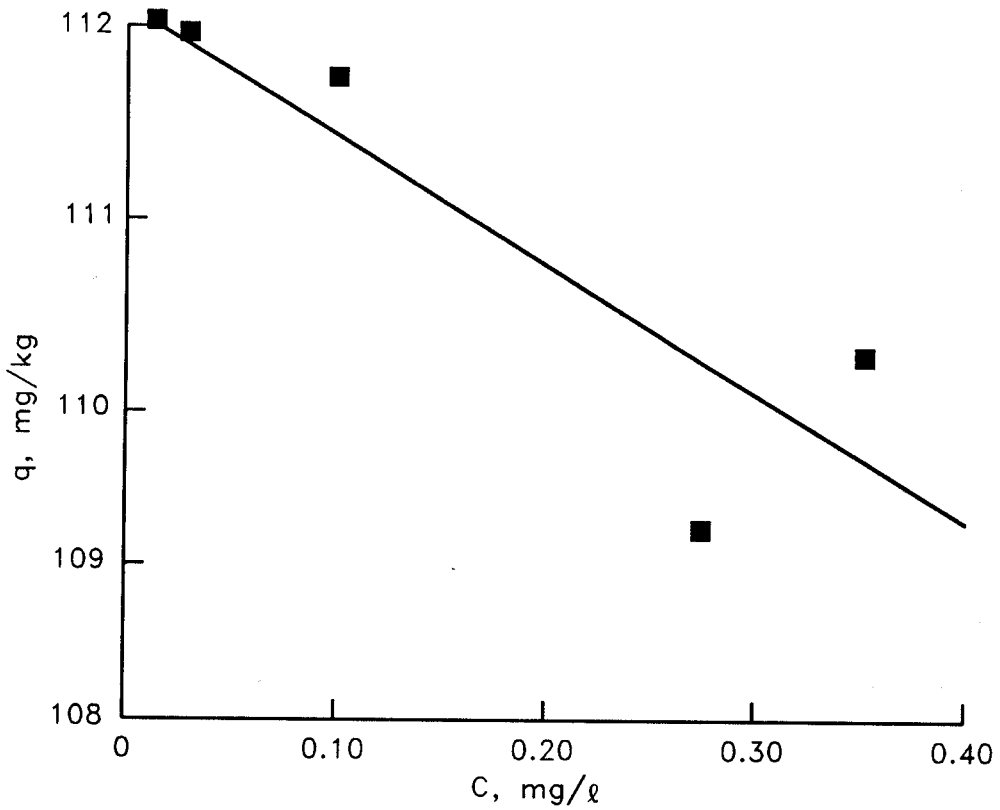

Figure A19. PCB congener C136 desorption isotherm for hot-spot New Bedford Harbor sediment

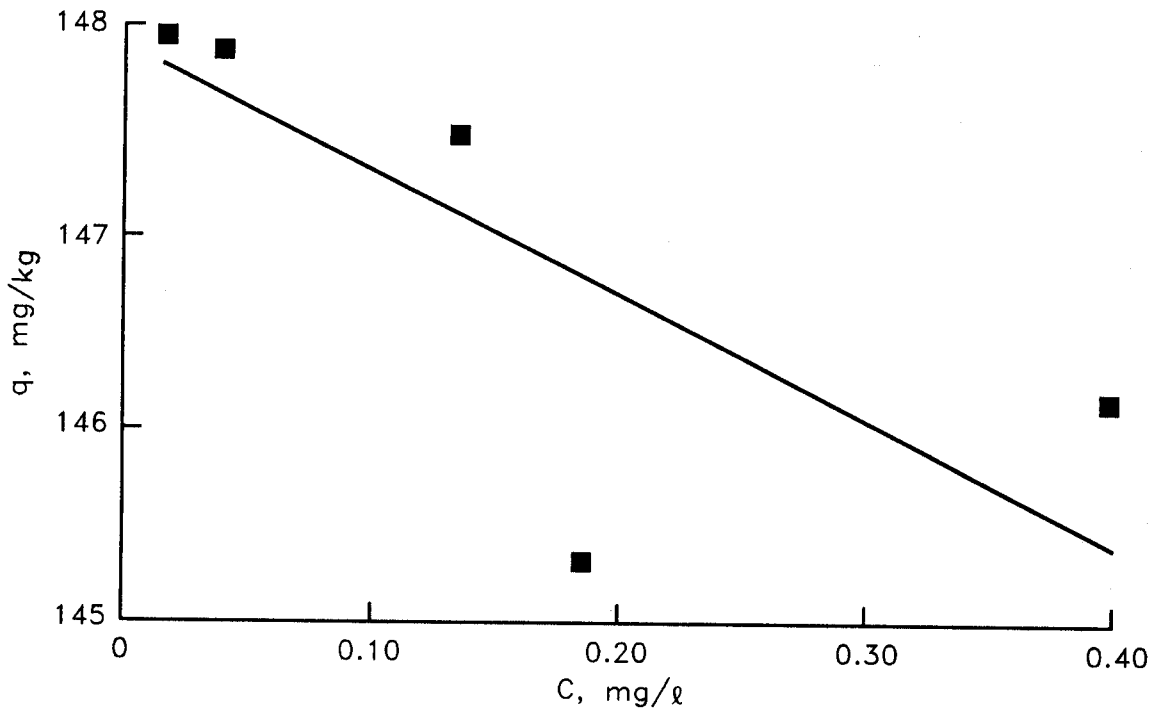

Figure A20. PCB congener C138 desorption isotherm for hot-spot New Bedford Harbor sediment

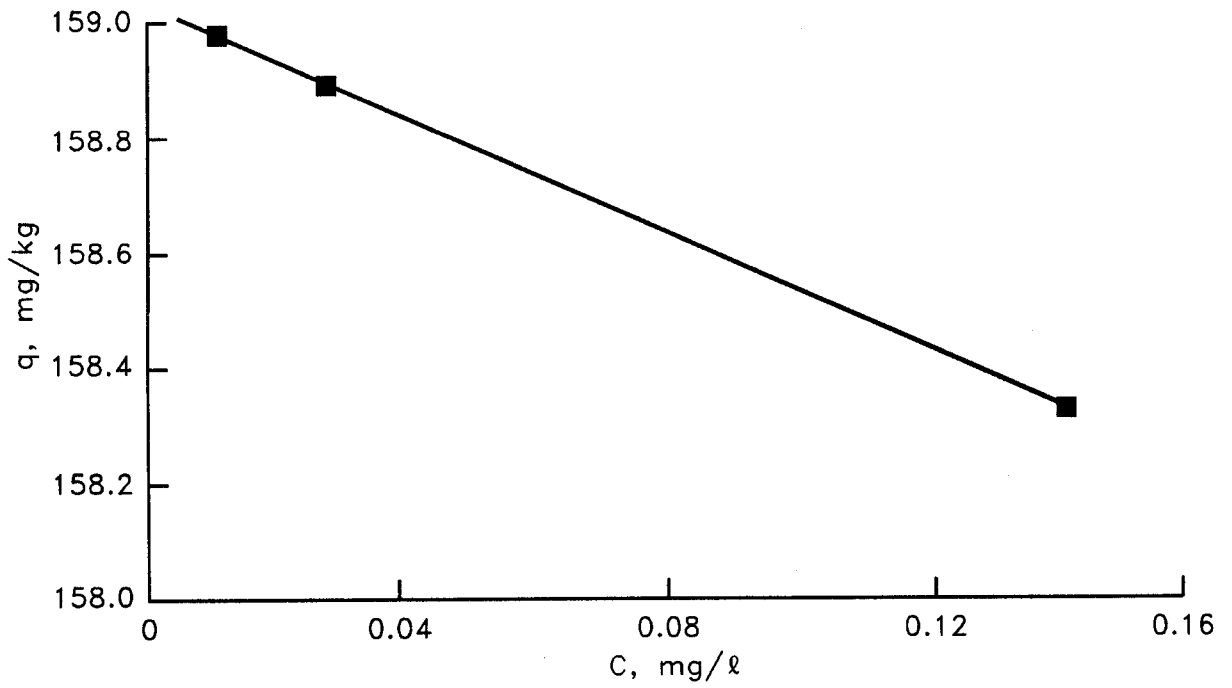

Figure A21. PCB congener C143 desorption isotherm for hot-spot New Bedford Harbor sediment

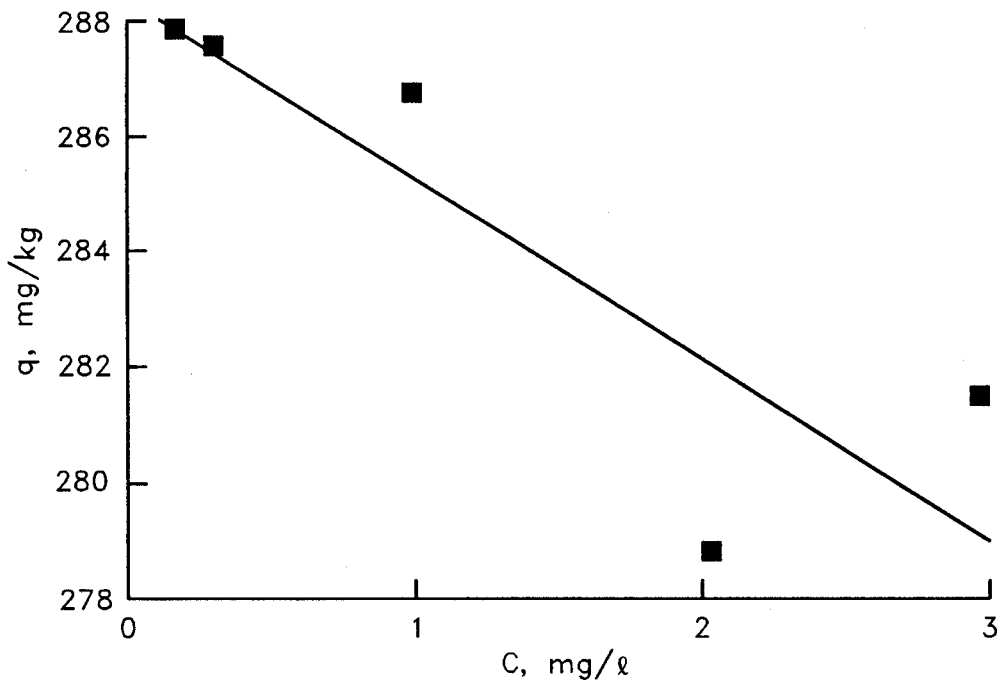

Figure A22. PCB congener C153 desorption isotherm for hot-spot New Bedford Harbor sediment

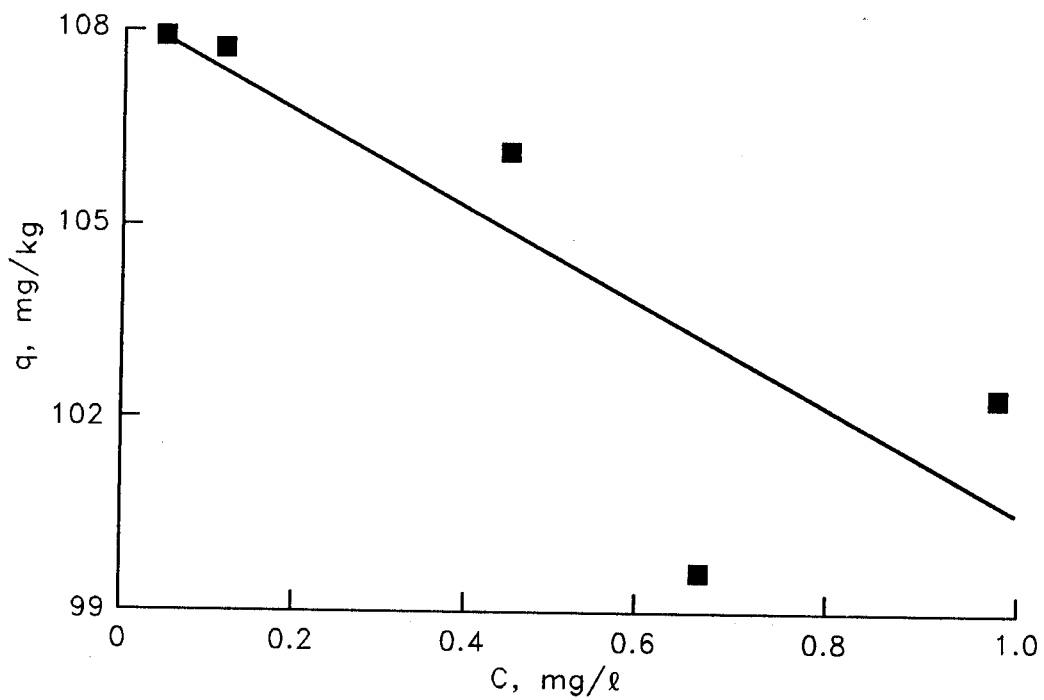

Figure A23. PCB congener C155 desorption isotherm for hot-spot New Bedford Harbor sediment

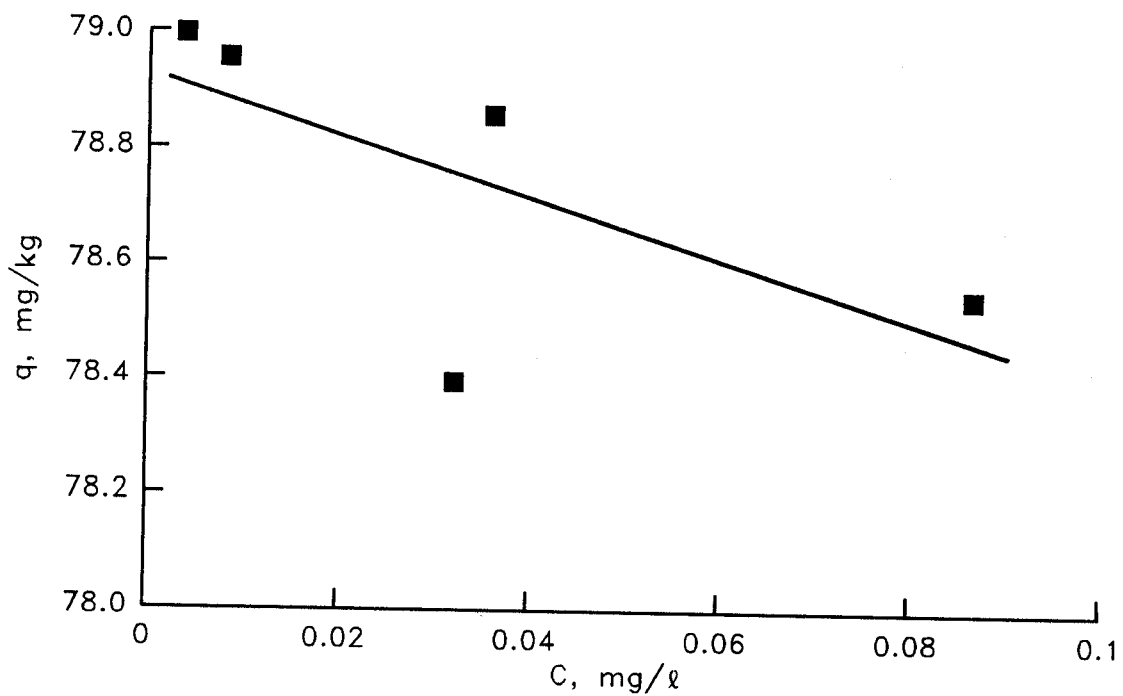

Figure A24. PCB congener C167 desorption isotherm for hot-spot New Bedford Harbor sediment

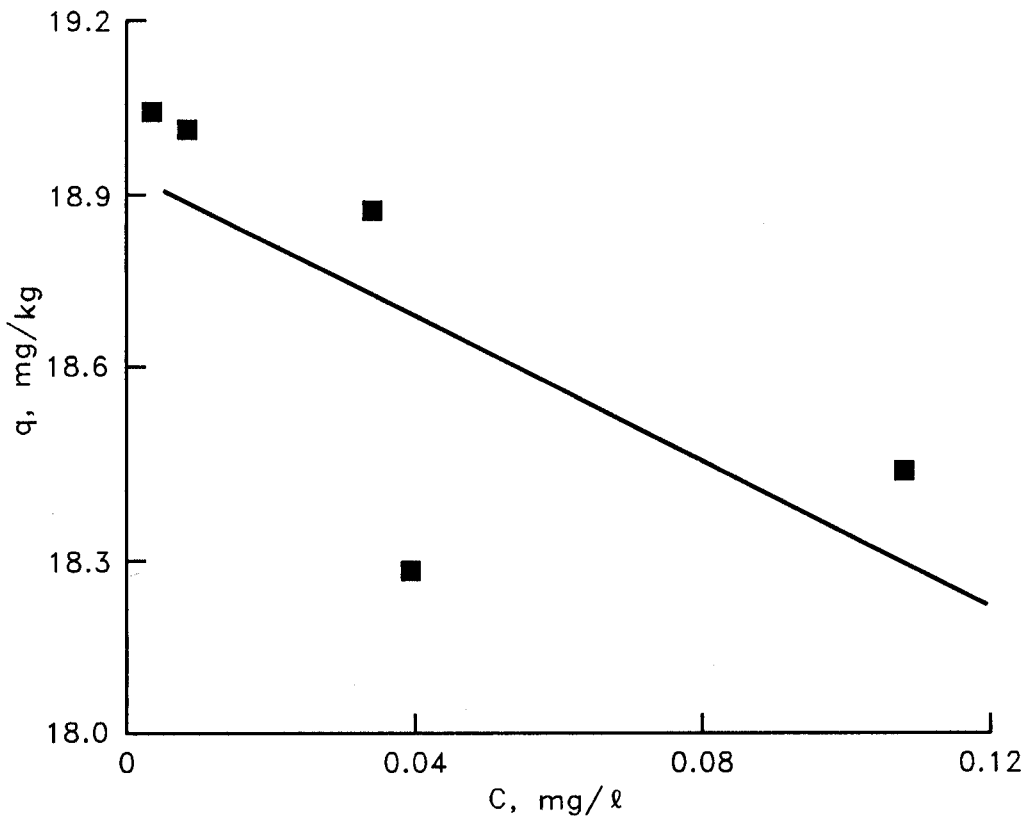

Figure A25. PCB congener C180 desorption isotherm for hot-spot New Bedford Harbor sediment

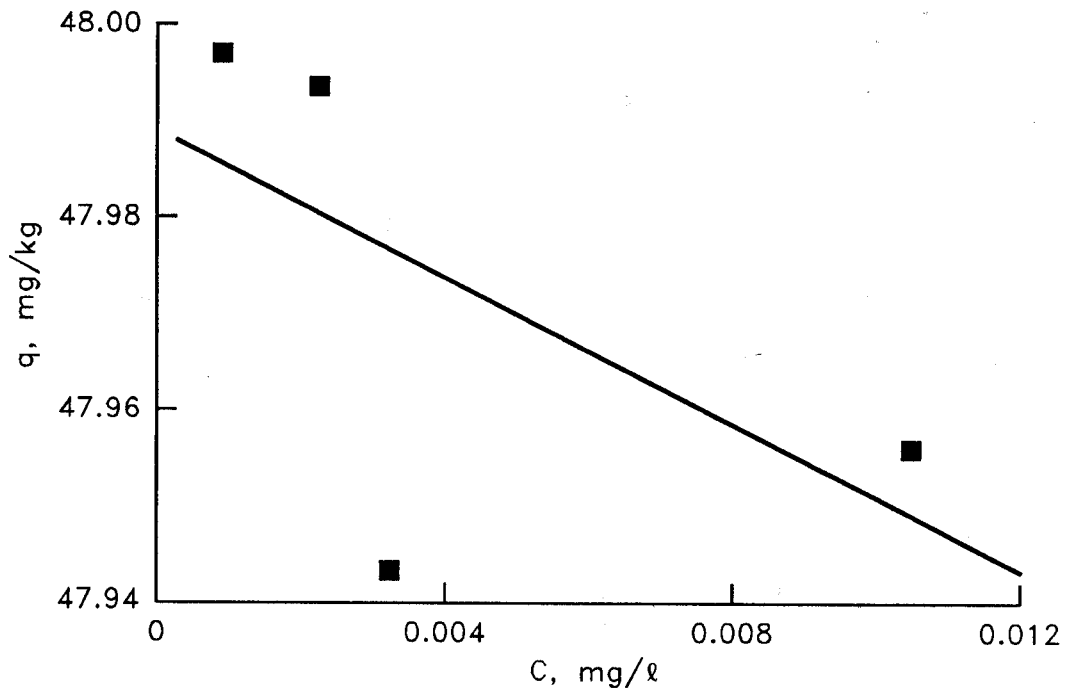

Figure A26. PCB congener C185 desorption isotherm for hot-spot New Bedford Harbor sediment

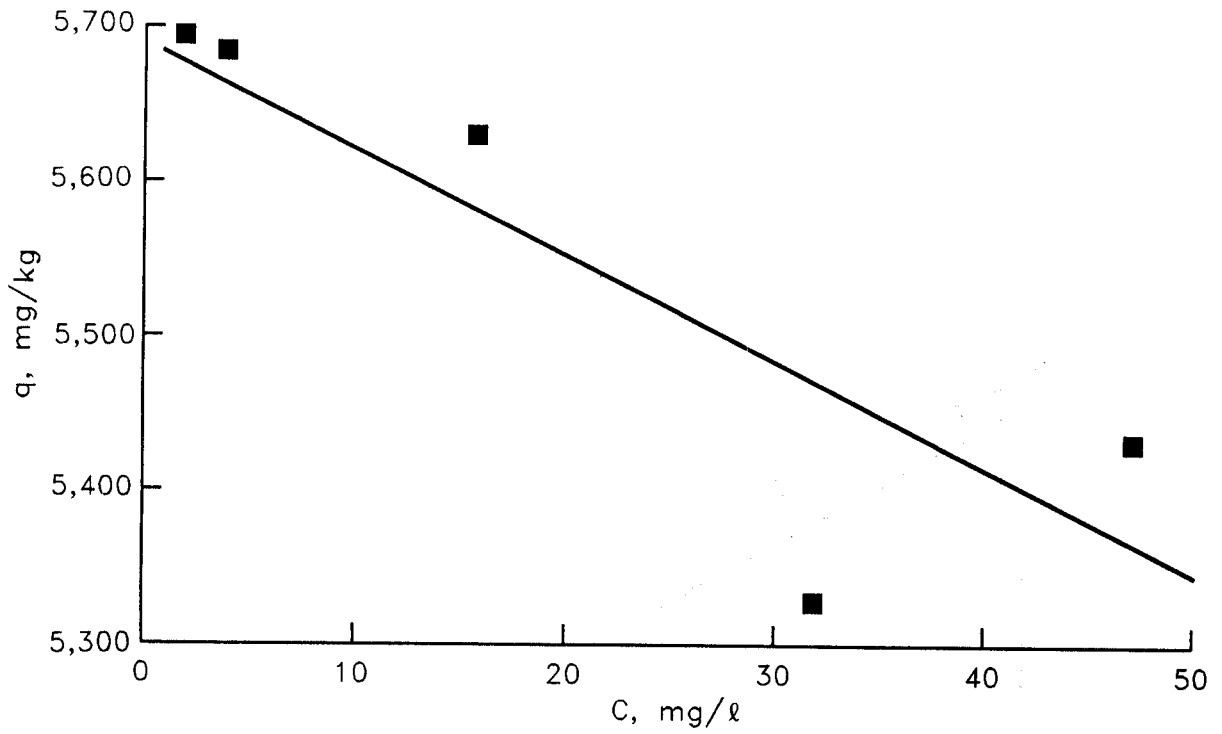

Figure A27. Aroclor 1242 desorption isotherm for hot-spot New Bedford Harbor sediment

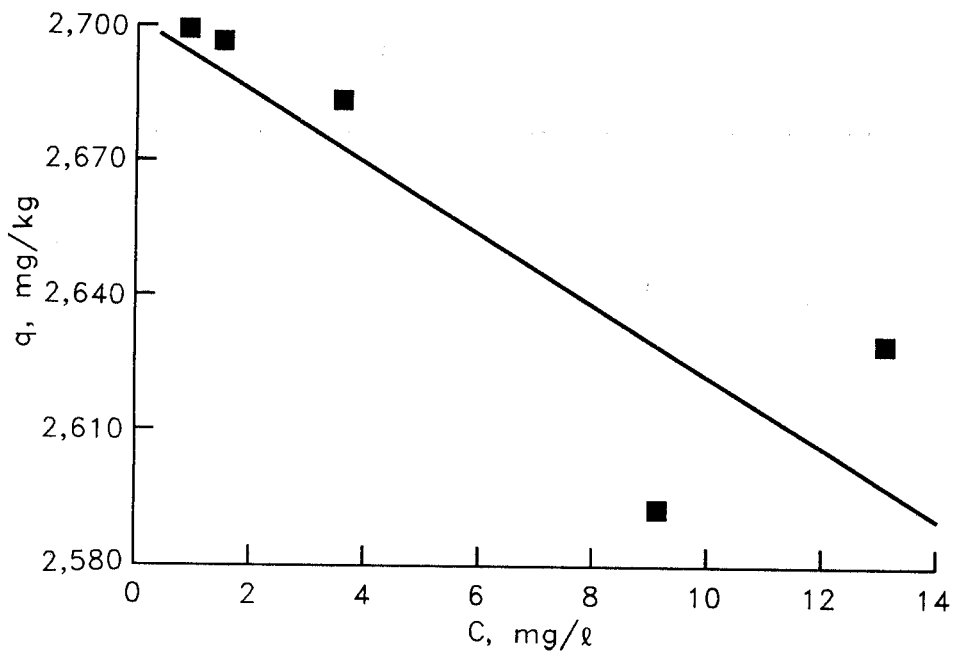

Figure A28. Aroclor 1254 desorption isotherm for hot-spot New Bedford Harbor sediment

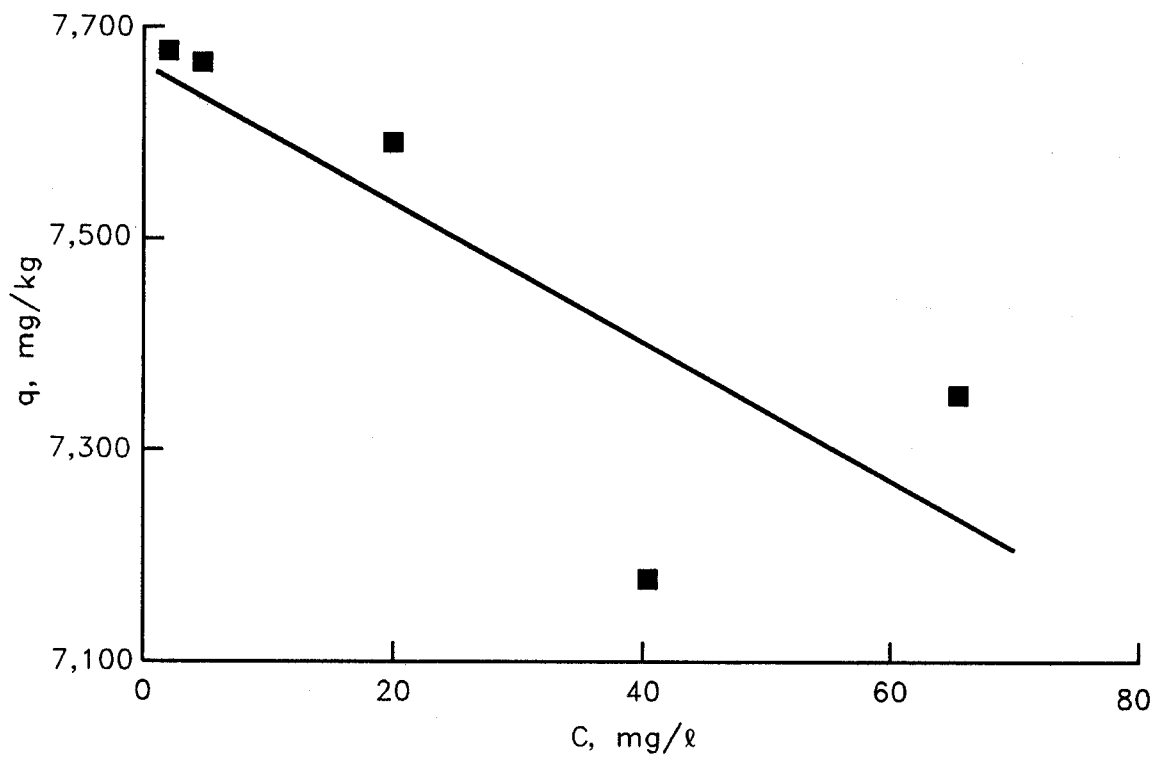

Figure A29. Total PCB desorption isotherm for hot-spot New Bedford Harbor sediment

APPENDIX B: SINGLE-STEP AND SEQUENTIAL BATCH LEACH DATA AND
DESORPTION ISOTHERMS FOR SOLIDIFIED/STABILIZED SEDIMENTS
FROM NEW BEDFORD HARBOR

1. This appendix is arranged as follows: analysis of blanks, presentation of batch leach data, and presentation of desorption isotherm plots. Chemical analysis of blanks is the basis for accepting/rejecting chemical data and is, therefore, discussed first.

Analysis of Blanks

2. Chemical analysis of the blanks for metals and dissolved organic carbon (DOC) is summarized in Tables B1-B3. Tables B1 and B2 are statistical summaries of metal and DOC blanks on midrange concentration composite sediment for the portland cement (PC) and portland cement with Firmix (F) processes, respectively. Table B3 is a statistical summary of the metal and DOC blanks for solidified/ stabilized hot-spot sediment (both the portland cement and Silicate Technology Corporation (STC) processes) and midrange concentration composite sediment solidified/stabilized with the STC additive. The results are presented in separate tables because the leachate samples and blanks were submitted for analysis as three distinct groups, one for midrange concentration composite sediment processed with portland cement, one for midrange concentration composite sediment processed using portland cement with Firmix, and one for solidified/stabilized hot-spot sediment and midrange concentration composite sediment solidified/stabilized with the STC additive. Within each group there is one blank for each process formulation and each step in the sequential leach procedure. Tables B1-B3 list concentration means, ranges, and standard deviations for cadmium (Cd), chromium (Cr), copper (Cu), nickel (Ni), lead (Pb), zinc (Zn), and DOC for the portland cement and portland cement with Firmix groups, respectively. Detection limits are also listed for each parameter.

3. Cadmium and DOC concentrations were near or below the detection limits in all blanks. Chromium, copper, and nickel concentrations in the blanks were measurable, but the means were near the detection limit and the ranges were generally one order of magnitude below the concentrations in the leachate samples. Since these data indicate that sources of contamination were under control during leach testing, sample preparation, and sample analysis, the leachate samples for cadmium, chromium, copper, nickel, and DOC were not corrected for blank concentrations.

4. Lead data for the third and fourth steps in the sequential leach tests on midrange concentration composite sediment solidified/stabilized with portland cement were not used to calculate the statistics presented in Table B1. Lead concentrations in these blanks were approximately the same as the leachate samples. Blanks and leachates for lead in the third and fourth steps of the sequential batch leach test of the portland cement process were therefore rejected, and these data were not used to evaluate chemical stabilization effectiveness. For the remaining blanks, lead was at or near the detection limit, indicating that the contamination was under control and that blank correction was not needed.

5. Zinc was below the detection limit in all the blanks for two groups of leachate samples (Tables B1 and B2). In the third group (Table B3), the mean and range were approximately the same as the leachate samples. Zinc leachate data for solidified/stabilized hot-spot sediment and midrange concentration composite sediment solidified/stabilized with portland cement were therefore rejected, and these data were not used to evaluate chemical stabilization effectiveness.

6. In the single-step batch leach tests for PCBs, a total of six blanks were prepared, one for each process formulation. The blanks were all near or below the detection limits (Table B4). Since the PCB concentrations in the leachate samples were all well above the detection limits, PCB concentrations in the leachate samples were not corrected for blank concentrations. Ten blanks were carried through the sequential batch leach tests for PCBs. Table B5 is a statistical summary of the chemical analyses of these blanks. As with the blanks for the single-step batch leach tests, the blank means and ranges were near or below the detection limits. The PCB concentrations in the leachate samples from the sequential batch leach tests were not corrected for blank concentrations.

Solidified/Stabilized Sediment and Additive Bulk Chemical Analysis

7. Bulk chemical analyses of setting agents for metals are presented in Table B6. Bulk chemical analyses of solidified/stabilized sediments for metals and PCBs are presented in Tables B7 and B8, respectively. The values

in Tables B7 and B8 were used as initial solid phase contaminant concentrations q_0 in Equation 3.

Sequential Batch Leach Data for Metals and Dissolved Organic Carbon

General leachate quality

8. Leachate conductivity gradually decreased during sequential leaching of solidified/stabilized New Bedford Harbor sediments (Table B9). Sequential leaching did not result in significant changes in leachate pH (see Table 10 of the main text).

Metals and DOC

9. Data from the sequential batch leach tests for metals and DOC on solidified/stabilized New Bedford Harbor sediments are presented in Tables B10-B27. The tables are organized by process and process formulation and present either mean leachate concentrations and standard error or solid phase concentrations calculated using the mean leachate concentrations and Equation 3. Metal and DOC desorption isotherms are presented in Figures B1-B54.

PCB Leach Data

10. Mean leachate concentrations and standard error from single-step batch leach tests for PCBs on solidified/stabilized midrange concentration composite sediment from New Bedford Harbor are presented in Table B19. The PCB data from sequential batch leach tests on solidified/stabilized New Bedford Harbor sediments are presented in Tables B28-B33. These tables are organized by process and present either mean leachate concentration and standard error for the PCB parameters or solid phase concentrations calculated using the mean leachate concentrations and Equation 3. The PCB desorption isotherms are presented in Figures B55-B123. Desorption isotherms were not plotted for those data in which the mean leachate concentration was below the detection limit in all steps of the sequential leach tests.

Table B1
Statistical Summary of Metals and DOC Blanks for Sequential Batch Leach
Tests Conducted on Midrange Concentration Composite Sample--New Bedford
Harbor Sediment Solidified/Stabilized with
Portland Cement

<u>Parameter</u>	<u>Cd</u>	<u>Cr</u>	<u>Cu</u>	<u>Ni</u>	<u>Pb</u>	<u>Zn</u>	<u>DOC</u>
Detection limit, mg/l	0.0001	0.001	0.001	0.001	0.001	0.03	1
Number of blanks	11+	12	12	12	5*,**	12	12
Number of blanks below detection limits	10	1	0	0	2	12	12
Range, mg/l	-0.0001 to 0.0001	<0.001 to 0.008	0.001 to 0.007	0.001 to 0.004	<0.0001 to 0.002	<0.03 to <0.03	<1 to <1
Mean, mg/l†	<0.0001	0.0041	0.003	0.002	0.0012	<0.03	<1
Standard deviation, mg/l†	<0.0001	0.0026	0.002	0.001	0.0008	<0.03	<1

* Contamination in blanks for third and fourth steps; therefore, step nos. 3 and 4 not included in data analysis.

** One blank analysis in set was lost during analysis.

† Means and standard deviations calculated using one half of detection limit for values below the detection limit.

Table B2

Statistical Summary of Metals and DOC Blanks for Sequential Batch Leach Tests Conducted on Midrange Concentration Composite Sample--New Bedford Harbor Sediment Solidified/Stabilized with Portland Cement and Firmix

	<u>Cd</u>	<u>Cr</u>	<u>Cu</u>	<u>Ni</u>	<u>Pb</u>	<u>Zn</u>	<u>DOC</u>
Detection limit, mg/ℓ	0.0001	0.001	0.001	0.001	0.001	0.03	1
Number of blanks	12	12	12	12	12	12	12
Number of blanks below detection limits	12	0	3	1	2	12	12
Range, mg/ℓ	<0.0001 to <0.0001	0.004 to 0.013	<0.001 to 0.003	<0.001 to 0.009	<0.001 to 0.01	<0.03 to <0.03	<1 to <1
Mean, mg/ℓ*	<0.0001	0.0076	0.0019	0.0027	0.0033	<0.03	<1
Standard deviation, mg/ℓ*	<0.0001	0.0026	0.0010	0.0023	0.0027	<0.03	<1

* Means and standard deviations calculated using one half of detection limit for values below the detection limit.

Table B3

Statistical Summary of Metals and DOC Blanks for Sequential Batch Leach
Tests Conducted on Solidified/Stabilized Hot-Spot Sediment Processed
and Midrange Concentration Composite Sediment Processed Using
Silicate Technology Corporation Proprietary Additive

	<u>Cd</u>	<u>Cr</u>	<u>Cu</u>	<u>Ni</u>	<u>Pb</u>	<u>Zn</u>	<u>DOC</u>
Detection limit, mg/l	0.0001	0.001	0.001	0.001	0.001	0.03	1
Number of blanks	15	15	15	15	15	15	15
Number of blanks below detection limits	14	8	0	0	12	7	15
Range, mg/l	<0.0001 to 0.0002	<0.001 to 0.004	0.003 to 0.009	0.001 to 0.019	<0.001 to 0.002	<0.03 to 0.216	<1 to <1
Mean, mg/l*	<0.0001	0.0016	0.0047	0.0033	<0.001	0.046	<1
Standard deviation, mg/l*	<0.0001	0.0014	0.0018	0.0045	<0.001	0.052	<1

* Means and standard deviations calculated using one half of detection limit for values below the detection limit.

Table B4

Statistical Summary of PCB Blanks for Single-Step Batch Leach Tests
Conducted on Solidified/Stabilized Midrange Concentration
Composite Sediment from New Bedford Harbor

<u>Parameter*</u>	<u>Detection Limit</u> <u>mg/l</u>	<u>Number of Blanks</u> <u>BDL**, †</u>	<u>Range</u> <u>mg/l</u>	<u>Mean</u> <u>mg/l</u>	<u>Standard Deviation</u> <u>mg/l</u>
A1016	0.0002	6	BDL	BDL	BDL
A1221	0.0002	6	BDL	BDL	BDL
A1232	0.0002	6	BDL	BDL	BDL
A1242	0.0002	6	BDL	BDL	BDL
A1248	0.0002	6	BDL	BDL	BDL
A1254	0.0002	6	BDL	BDL	BDL
A1260	0.0002	6	BDL	BDL	BDL
C7	0.00001	5	BDL-0.00003	0.00001	0.00001
C8	0.00001	6	BDL	BDL	BDL
C28	0.00001	5	BDL-0.00007	0.00002	0.00003
C44	0.00001	5	BDL-0.00002	BDL	BDL
C49	0.00001	4	BDL-0.00001	BDL	BDL
C50	0.00001	4	BDL-0.00007	0.00003	0.00003
C52	0.00001	5	BDL-0.00007	0.00002	0.00003
C70	0.00001	3	BDL-0.00022	0.00007	0.00010
C77	0.00001	5	BDL-0.00005	0.00001	0.00002
C82	0.00001	4	BDL-0.00003	0.00001	0.00001
C87	0.00001	4	BDL-0.00006	0.00002	0.00003
C97	0.00001	5	BDL-0.00002	BDL	BDL
C101	0.00001	5	BDL-0.00004	0.00001	0.00001
C105	0.00001	6	BDL	BDL	BDL
C118	0.00001	6	BDL	BDL	BDL
C136	0.00001	5	BDL-0.000003	0.00001	0.00001
C138	0.00001	3	BDL-0.00017	0.00005	0.00007
C143	0.00001	6	BDL	BDL	BDL
C153	0.00001	5	BDL-0.00002	BDL	BDL
C155	0.00001	5	--	--	--
C167	0.00001	6	BDL	BDL	BDL
C180	0.00001	5	BDL-0.00001	BDL	BDL
C185	0.00001	6	BDL	BDL	BDL
Total PCB	0.0002	5	BDL-0.0003	0.0001	0.0001

* See Table 5 of main text for PCB identification key.

** BDL: Below detection limit.

† Six blanks were carried through shaking, filtration, and analytical procedures.

Table B5

Statistical Summary of PCB Blanks for Sequential Batch Leach Tests
Conducted on Solidified/Stabilized New Bedford Harbor Sediments

<u>Parameter</u>	<u>Detection Limit mg/l</u>	<u>Number of Blanks BDL*,**</u>	<u>Range mg/l</u>	<u>Mean mg/l</u>	<u>Standard Deviation mg/l</u>
A1016	0.0002	10	BDL	BDL	BDL
A1221	0.0002	10	BDL	BDL	BDL
A1232	0.0002	10	BDL	BDL	BDL
A1242	0.0002	3	BDL-0.0009	0.0003	0.0002
A1248	0.0002	10	BDL	BDL	BDL
A1254	0.0002	5	BDL-0.0007	0.0003	0.0002
A1260	0.0002	10	BDL	BDL	BDL
C7	0.00001	10	BDL	BDL	BDL
C8	0.00001	10	BDL	BDL	BDL
C28	0.00001	6	BDL-0.00007	0.00002	0.00002
C44	0.00001	6	BDL-0.00002	0.00001	BDL
C49	0.00001	10	BDL	BDL	BDL
C50	0.00001	7	BDL-0.00003	0.00001	0.00001
C52	0.00001	6	BDL-0.00005	0.00002	0.00002
C70	0.00001	6	BDL-0.00002	0.00001	BDL
C77	0.00001	7	BDL-0.00007	0.00002	0.00003
C82	0.00001	9	BDL-0.00001	BDL	BDL
C87	0.00001	7	BDL-0.00002	BDL	BDL
C97	0.00001	6	BDL-0.00002	BDL	BDL
C101	0.00001	6	BDL-0.00011	0.00003	0.00003
C105	0.00001	9	BDL-0.00001	BDL	BDL
C118	0.00001	4	BDL-0.00002	0.00001	BDL
C136	0.00001	7	BDL-0.00001	BDL	BDL
C138	0.00001	5	BDL-0.00002	BDL	BDL
C143	0.00001	9	BDL-0.00001	BDL	BDL
C153	0.00001	6	BDL-0.00002	BDL	BDL
C155	0.00001	7	BDL-0.00004	0.00001	0.00001
C167	0.00001	6	BDL-0.00011	0.00002	0.00003
C180	0.00001	8	BDL-0.00001	BDL	BDL
C185	0.00001	10	BDL	BDL	BDL
Total PCB	0.0002	3	BDL-0.0019	0.0007	0.0007

* Below detection limit.

** Ten blanks were carried through shaking, filtration, and analytical procedures.

Table B6

Contaminant Concentrations in Solidification/Stabilization Binders Used
to Process New Bedford Sediments, mg/kg (Standard Error)

Contaminant	Type I		STC**
	Portland Cement*	Firmix*	
Cadmium	0.11 (0.007)	0.06 (0.010)	3.24
Chromium	48 (0.712)	20 (0.268)	112
Copper	20.6 (0.034)	1.03 (0.054)	172
Lead	41.6 (0.504)	0.12 (0.037)	132
Nickel	26.2 (0.268)	1.33 (0.037)	24
Zinc	426 (2.33)	<3.0 (---)	556

* Mean of three replicates.

** No replication.

Table B7

Initial Solid Phase Metals Concentrations (q_0), mg/kg (Standard Error)

Process	Contaminant					
	Cd	Cr	Cu	Pb	Ni	Zn
0.1 PC	26.4 (0.1186)	509 (36.53)	1,277 (5.443)	506 (3.182)	98.6 (1.400)	2,210 (21.60)
0.2 PC	21.5 (0.0720)	434 (7.257)	959 (10.39)	480 (6.901)	81.3 (1.060)	1,826 (30.31)
0.3 PC	17.5 (0.1905)	350 (3.4101)	775 (2.880)	476 (7.216)	69.2 (0.8259)	1,520 (9.428)
0.2 PC:0.1 F	14.2 (0.8331)	337 (4.769)	743 (8.489)	435 (11.97)	62.3 (1.025)	1,430 (16.32)
0.15 PC:0.15 F	16.8 (0.2160)	376 (6.672)	811 (20.33)	439 (13.75)	66.1 (1.283)	1,586 (59.69)
0.1 PC:0.2 F	18.6 (0.2055)	384 (8.998)	821 (15.84)	445 (7.808)	66.7 (1.698)	1,563 (30.67)
0.3 STC - Midrange	18.1 (0.2762)	372 (3.139)	768 (10.96)	418 (26.67)	62.0 (0.9572)	1,417 (19.05)
0.3 PC - Hot-spot	17.0 (0.1089)	278 (1.656)	636 (1.361)	368 (2.357)	53.7 (0.3067)	1,693 (5.443)
0.3 STC - Hot-spot	17.2 (0.4225)	279 (4.996)	600 (7.760)	345 (2.596)	44.7 (0.3031)	1,553 (11.86)

Table B8

Initial Solid Phase PCB Concentrations (q_0), mg/kg (Standard Error)

Contaminant	0.3 PC - Hot-Spot	0.3 STC - Hot Spot	0.3 STC - Midrange
Aroclor 1016	<20 (---)	<20 (---)	<20 (---)
Aroclor 1221	<20 (---)	<20 (---)	<20 (---)
Aroclor 1232	<20 (---)	<20 (---)	<20 (---)
Aroclor 1242	1,883 (270.6)	2,633 (268.0)	783 (33.83)
Aroclor 1248	<20 (---)	<20 (---)	<20 (---)
Aroclor 1254	1,383 (181.6)	1,128 (75.14)	312 (16.43)
Aroclor 1260	<20 (---)	<20 (---)	<20 (---)
Total PCBs	3,283 (462.1)	3,768 (212.6)	1,097 (49.52)
C7	1.1 (0.1460)	0.80 (0.0260)	0.30 (0.0260)
C8	70 (19.53)	240 (28.67)	79 (6.672)
C28	140 (17.00)	393 (39.25)	133 (5.443)
C44	61 (8.304)	108 (9.526)	30 (0.4710)
C49	28 (0.7200)	33 (2.419)	13.7 (0.5440)
C50	65 (4.109)	171 (17.59)	56 (0.9430)
C52	133 (2.722)	191 (17.21)	81 (1.785)
C70	66 (4.028)	123 (10.01)	23 (0.7200)
C77	316 (14.40)	373 (14.62)	106 (1.785)
C82	<0.01 (---)	<0.01 (---)	<0.01 (---)
C87	84 (7.363)	41 (19.47)	11.5 (1.197)
C97	92 (24.63)	91 (15.90)	24 (1.089)
C101	80 (2.449)	140 (4.714)	37 (1.414)
C105	9.3 (3.924)	13.5 (6.754)	5.5 (2.718)
C118	102 (32.25)	72 (7.779)	18.7 (1.963)
C136	86 (7.458)	37 (10.77)	9.2 (0.6400)
C138	59 (4.906)	23 (3.209)	12.3 (0.2720)
C143	38 (7.518)	17 (2.325)	7.1 (1.318)
C153	115 (34.01)	41 (6.277)	20 (3.839)
C155	<0.01 (---)	<0.01 (---)	<0.01 (---)
C167	25 (20.41)	10.4 (3.501)	<0.01 (---)
C180	18 (10.84)	3.6 (0.4110)	2.8 (1.044)
C185	<0.01 (---)	0.90 (0.3650)	1.1 (0.4640)

Table B9

Composite Leachate Conductivity in Sequential Batch Leach Tests Conducted
on Solidified/Stabilized New Bedford Harbor Sediments, μ hos

<u>Process and Sediment Type</u>	<u>Step Number</u>				
	<u>1</u>	<u>2</u>	<u>3</u>	<u>4</u>	<u>5</u>
Midrange concentration composite					
0.1 PC	6,000	3,000	1,700	1,600	--
0.2 PC	8,000	4,000	1,900	2,300	--
0.3 PC	7,000	6,000	4,500	4,700	--
0.2 PC:0.1 F	6,100	1,400	1,000	2,000	--
0.15 PC:0.15 F	6,600	1,300	600	240	--
0.1 PC:0.2 F	6,200	2,500	1,400	440	--
0.3 STC	7,800	4,100	1,900	1,700	1,300
Hot-spot sediment					
0.3 PC	9,500	4,900	1,900	2,000	980
0.3 STC	13,000	9,000	6,000	6,700	5,400

Note: Composite samples of replicate leachates for each step.

Table B10

Metal and DOC Leachate Concentrations in Sequential Batch Leach Test for 0.1 Portland
Cement Processed Midrange Concentration Sediment, mg/l (Standard Error)

<u>Contaminant</u>	<u>Step Number</u>			
	<u>1</u>	<u>2</u>	<u>3</u>	<u>4</u>
Cadmium	0.000183 (0.000089)	0.00175 (0.0013)	<0.0001 (--)	<0.0001 (--)
Chromium	0.056 (0.000471)	0.076 (0.00327)	0.104 (0.00260)	0.0141 (0.00262)
Copper	14.8 (0.141)	6.46 (0.187)	3.67 (0.0764)	2.68 (0.0484)
Lead	0.0653 (0.00218)	0.0423 (0.00223)	0.034 (0.00741)	0.035 (0.000816)
Nickel	1.38 (0.0125)	0.469 (0.0126)	0.188 (0.00395)	0.104 (0.00166)
Zinc	0.048 (0.00829)	0.03 (0.00544)	<0.03 (--)	<0.03 (--)
DOC	311.0 (11.671)	121.3 (3.953)	59.0 (1.247)	46.7 (0.5443)

Table B11

Metal and DOC Solid Phase Concentrations in Sequential Batch Leach Test
for 0.1 Portland Cement Processed Midrange Sediment, mg/kg*

<u>Contaminant</u>	<u>Step Number</u>			
	<u>1</u>	<u>2</u>	<u>3</u>	<u>4</u>
Cadmium	26.39937	26.39341	26.39341	26.39341
Chromium	560.5093	560.2505	559.8953	559.4152
Copper	1,226.31	1,204.304	1,191.82	1,182.684
Lead	506.7775	506.6334	506.5176	506.3984
Nickel	93.9015	92.3058	91.6668	91.3139
Zinc	2,209.836	2,209.836	2,209.836	2,209.836
DOC	19,070.7	18,657.5	18,456.7	18,297.8

* Calculated using Equation 3 of main text.

Table B12

Metal and DOC Leachate Concentrations in Sequential Batch Leach Test for 0.2 Portland
Cement Processed Midrange Sediment, mg/l (Standard Error)

Contaminant	Step Number			
	1	2	3	4
Cadmium	0.000583 (0.000228)	0.000133 (0.000068)	<0.0001 (--)	<0.0001 (--)
Chromium	0.04867 (0.00178)	0.059 (0.000816)	0.075 (0.00125)	0.101 (0.000471)
Copper	6.36 (0.0109)	3.51 (0.00741)	2.38 (0.0504)	1.89 (0.0546)
Lead	0.204 (0.00741)	0.111 (0.00386)	0.0187 (0.00072)	0.0553 (0.00425)
Nickel	0.750 (0.00406)	0.326 (0.00811)	0.173 (0.00341)	0.118 (0.00334)
Zinc	0.0833 (0.0139)	0.041 (0.00189)	0.03 (0.00489)	<0.03 (--)
DOC	211.0 (15.63)	56.0 (0.8165)	54.7 (1.905)	49.3 (0.7201)

Table B13

Metal and DOC Solid Phase Concentrations in Sequential Batch Leach Tests for
0.2 Portland Cement Processed Midrange Sediment, mg/kg*

Contaminant	Step Number			
	1	2	3	4
Cadmium	21.468	21.468	21.468	21.468
Chromium	433.836	433.638	433.386	433.047
Copper	937.320	925.516	917.531	911.170
Lead	479.615	479.237	479.173	478.985
Nickel	78.811	77.717	77.137	76.742
Zinc	1,826.420	1,826.280	1,826.280	1,826.280
DOC	15,750.2	15,559.6	15,373.4	15,205.5

* Calculated using Equation 3.

Table B14

Metal and DOC Leachate Concentrations in Sequential Batch Leach Test for 0.3 Portland
Cement Processed Midrange Sediment, mg/l (Standard Error)

<u>Contaminant</u>	<u>Step Number</u>			
	<u>1</u>	<u>2</u>	<u>3</u>	<u>4</u>
Cadmium	<0.0003 (--)	<0.0003 (--)	<0.0003 (--)	<0.0003 (-)
Chromium	0.0507 (0.00152)	0.0357 (0.000272)	0.033 (0.000942)	0.0343 (0.00191)
Copper	5.39 (0.0223)	2.49 (0.0544)	1.50 (0.0196)	1.20 (0.0357)
Lead	0.228 (0.0778)	0.222 (0.00386)	0.0187 (0.00484)	0.208 (0.00626)
Nickel	0.732 (0.00849)	0.264 (0.00579)	0.134 (0.00213)	0.0917 (0.00314)
Zinc	0.052 (0.00356)	0.0587 (0.0119)	0.0387 (0.00366)	0.0463 (0.00519)
DOC	163.7 (21.546)	71.0 (--)	37.0 (0.4714)	39.7 (1.186)

Table B15

Metal and DOC Solid Phase Concentrations in Sequential Batch Leach Tests for
0.3 Portland Cement Processed Midrange Sediment, mg/kg*

<u>Contaminant</u>	<u>Step Number</u>			
	<u>1</u>	<u>2</u>	<u>3</u>	<u>4</u>
Cadmium	17.469	17.469	17.469	17.469
Chromium	350.153	350.028	349.913	349.793
Copper	755.841	747.475	742.424	738.404
Lead	474.874	474.128	474.066	473.366
Nickel	68.84	67.953	67.504	67.196
Zinc	1,513.118	1,512.918	1,512.786	1,512.629
DOC	13,348.8	1,317.2	12,981.0	12,846.0

* Calculated using Equation 3.

Table B16

Metal and DOC Leachate Concentrations in Sequential Batch Leach Test for 0.2 Portland
Cement 0.1 Firmix Processed Midrange Sediment, mg/l (Standard Error)

Contaminant	Step Number			
	1	2	3	4
Cadmium	<0.0001 (--)	<0.0001 (--)	<0.0001 (--)	<0.0001 (--)
Chromium	0.0607 (0.000981)	0.0690 (0.000942)	0.0680 (0.00283)	0.0750 (0.000471)
Copper	5.25 (0.0608)	2.77 (0.0218)	1.78 (0.0357)	1.36 (0.0109)
Lead	0.0787 (0.000981)	0.0423 (0.000981)	0.0477 (0.00213)	0.0420 (0.00403)
Nickel	0.473 (0.00303)	0.182 (0.00144)	0.0933 (0.00178)	0.058 (0.000816)
Zinc	<0.03 (--)	<0.03 (--)	<0.03 (--)	<0.03 (--)
DOC	209.7 (2.8414)	84.3 (5.040)	65.7 (0.5443)	45.0 (0.8165)

Table B17

Metal and DOC Solid Phase Concentrations in Sequential Batch Leach Tests for
0.2 Portland Cement:0.1 Firmix Processed Midrange Sediment, mg/kg*

Contaminant	Step Number			
	1	2	3	4
Cadmium	14.2	14.2	14.2	14.2
Chromium	336.793	336.558	336.327	336.071
Copper	725.133	715.684	709.631	704.986
Lead	434.732	434.588	434.425	424.282
Nickel	60.690	60.069	59.751	59.554
Zinc	1,430	1,430	1,430	1,430
DOC	13,206.9	12,919.5	12,695.8	12,542.5

* Calculated using Equation 3.

Table B18

Metal and DOC Leachate Concentrations in Sequential Batch Leach Test for 0.15 Portland
Cement:0.15 Firmix Processed Midrange Sediment, mg/l (Standard Error)

Contaminant	Step Number			
	1	2	3	4
Cadmium	<0.0001 (--)	<0.0001 (--)	<0.0001 (--)	<0.0001 (--)
Chromium	0.0933 (0.000720)	0.0867 (0.00109)	0.0777 (0.00223)	0.079 (0.00125)
Copper	6.17 (0.0263)	2.88 (0.0272)	1.65 (0.0303)	1.27 (0.0110)
Lead	0.030 (0.000816)	0.0213 (0.00109)	0.0287 (0.00260)	0.0187 (0.000981)
Nickel	0.478 (0.00166)	0.160 (0.00191)	0.07 (0.000816)	0.0423 (0.00152)
Zinc	<0.03 (--)	<0.03 (--)	<0.03 (--)	<0.03 (--)
DOC	236.0 (1.633)	92.7 (0.7201)	64.3 (0.2722)	43.0 (0.8165)

Table B19

Metal and DOC Solid Phase Concentrations in Sequential Batch Leach Tests for
0.15 Portland Cement:0.15 Firmix Processed Midrange Sediment, mg/kg*

Contaminant	Step Number			
	1	2	3	4
Cadmium	17.3	17.3	17.3	17.3
Chromium	375.682	375.387	375.122	374.853
Copper	789.979	780.155	774.522	770.206
Lead	438.898	438.825	438.727	438.664
Nickel	64.473	63.926	63.688	63.544
Zinc	1,590	1,590	1,590	1,590
DOC	13,116.8	12,801.1	12,581.9	12,435.4

* Calculated using Equation 3.

Table B20

Metal and DOC Leachate Concentrations in Sequential Batch Leach Test for 0.1 Portland Cement:0.2 Firmix Processed Midrange Sediment, mg/l (Standard Error)

Contaminant	Step Number			
	1	2	3	4
Cadmium	<0.0001 (--)	<0.0001 (--)	<0.0001 (--)	<0.0001 (--)
Chromium	0.0753 (0.00237)	0.0880 (0.00163)	.0860 (.000816)	0.0847 (0.00109)
Copper	7.40 (0.138)	3.26 (0.01247)	1.86 (0.0288)	1.31 (0.00471)
Lead	0.0177 (0.000272)	0.0160 (0.000471)	0.00833 (0.00368)	0.0130 (0.00309)
Nickel	0.581 (0.0132)	0.178 (0.00191)	0.0687 (0.000981)	0.0353 (0.000272)
Zinc	<0.03 (--)	<0.03 (--)	<0.03 (--)	<0.03 (--)
DOC	249.3 (1.440)	97.3 (0.9813)	66.7 (0.2722)	44.3 (0.2722)

Table B21

Metal and DOC Solid Phase Concentrations in Sequential Batch Leach Tests for 0.1 Portland Cement:0.2 Firmix Processed Midrange Sediment, mg/kg*

Contaminant	Step Number			
	1	2	3	4
Cadmium	18.6	18.6	18.6	18.6
Chromium	383.443	383.143	382.849	382.561
Copper	795.445	784.338	777.989	773.526
Lead	444.940	444.885	444.855	444.811
Nickel	64.887	64.279	64.045	63.925
Zinc	1,563	1,563	1,563	1,563
DOC	13,071.4	12,739.7	12,512.6	12,361.6

* Calculated using Equation 3.

Table B22

Metals and DOC Leachate Concentrations in Sequential Batch Leach Test for 0.3 STC Processed
Midrange Sediment, mg/l (Standard Error)

Contaminant	Step Number				
	1	2	3	4	5
Cadmium	0.0008 (0.000124)	0.00035 (0.000131)	<0.0001 (--)	0.000183 (0.000089)	0.0002 (0.000081)
Chromium	0.0223 (0.00119)	0.0503 (0.000720)	0.0634 (0.000272)	0.091 (0.00141)	0.111 (0.000816)
Copper	3.97 (0.0803)	3.04 (0.0233)	2.11 (0.0268)	1.74 (0.0141)	1.49 (0.00471)
Lead	0.004 (0.000471)	0.00433 (0.000272)	0.00333 (0.000544)	0.003 (0.000816)	0.001 (0.000136)
Nickel	0.784 (0.00189)	0.346 (0.00381)	0.160 (0.000942)	0.094 (0.000942)	0.0570 (0.00170)
Zinc	0.038 (0.00946)	0.0477 (0.0267)	0.0513 (0.00850)	0.0407 (0.0123)	<0.03 (--)
DOC	117.3 (0.8927)	75.6 (0.8706)	52.8 (0.3990)	37.0 (0.3398)	28.3 (0.3781)

Table B23

Metal and DOC Solid Phase Concentrations in Sequential Batch Leach
Test for 0.3 STC Processed Midrange Sediment, mg/kg*

Contaminant	Step Number				
	1	2	3	4	5
Cadmium	18.0981	18.0973	18.0973	18.0969	18.0965
Chromium	372.248	372.132	371.985	371.775	371.519
Copper	759.145	752.137	747.259	743.244	739.805
Lead	417.691	417.681	417.673	417.666	417.666
Nickel	60.191	59.393	59.024	58.807	58.675
Zinc	1,416.612	1,416.502	1,416.383	1,416.289	1,416.289
DOC	13,659.1	13,490.5	13,372.7	13,290.2	13,227.0

* Calculated using Equation 3.

Table B24
Metals and DOC Leachate Concentrations in Sequential Batch Leach Test for 0.3 Portland Cement
Processed Hot-Spot Sediment, mg/l (Standard Error)

Contaminant	Step Number				
	1	2	3	4	5
Cadmium	0.0000533 (0.000027)	0.000116 (0.000036)	<0.0001 (---)	<0.0001 (---)	0.000133 (0.000027)
Chromium	0.015 (0.000471)	0.0113 (0.000544)	0.008 (---)	0.008 (---)	0.0107 (0.000272)
Copper	8.29 (0.00981)	3.78 (0.0196)	2.17 (0.0354)	1.55 (0.0170)	1.27 (0.00942)
Lead	0.255 (0.0310)	0.159 (0.00191)	0.218 (0.0302)	0.126 (0.00242)	0.183 (0.00272)
Nickel	1.15 (0.00720)	0.460 (0.00141)	0.232 (0.00191)	0.143 (0.00152)	0.109 (0.00144)
Zinc	0.123 (0.00873)	0.0983 (0.00166)	0.116 (0.0266)	0.0773 (0.00268)	0.075 (0.00618)
DOC	257.3 (4.801)	137.5 (1.479)	72.8 (0.3921)	46.6 (0.7076)	36.6 (0.1031)

Table B25

Metal and DOC Solid Phase Concentrations in Sequential Batch Leach Test
for 0.3 Portland Cement Processed Hot-Spot Sediment, mg/kg*

<u>Contaminant</u>	<u>Step Number</u>				
	<u>1</u>	<u>2</u>	<u>3</u>	<u>4</u>	<u>5</u>
Cadmium	16.9652	16.9649	16.9649	16.9649	16.9649
Chromium	278.293	278.263	278.242	278.221	278.192
Copper	614.291	604.245	598.482	594.359	590.981
Lead	367.321	366.897	366.317	365.983	365.495
Nickel	50.590	49.366	48.748	48.367	48.078
Zinc	1,693.006	1,692.744	1,692.436	1,692.230	1,692.030
DOC	11,685.9	11,351.6	11,174.6	11,061.4	10,972.6

* Calculated using Equation 3.

Table B26

Metals and DOC Leachate Concentrations in Sequential Batch Leach Test for 0.3 STC Processed

Hot-Spot Sediment, mg/l (Standard Error)

Contaminant	Step Number				
	1	2	3	4	5
Cadmium	0.000633 (0.000027)	0.0006 (0.000081)	<0.0001 (---)	<0.0001 (---)	0.000116 (0.000036)
Chromium	0.038 (0.000942)	0.0597 (0.00144)	0.0743 (0.00125)	0.0833 (0.000272)	0.0963 (0.00272)
Copper	4.12 (0.0764)	2.76 (0.0307)	1.94 (0.0500)	1.58 (0.0144)	1.22 (0.0401)
Lead	0.005 (0.000471)	0.00367 (0.000272)	0.00333 (0.000942)	0.00233 (0.000544)	0.001 (0.000136)
Nickel	0.589 (0.00366)	0.264 (0.000471)	0.134 (0.00356)	0.074 (0.000942)	0.0447 (0.000544)
Zinc	0.0337 (0.00768)	0.0337 (0.00872)	0.0527 (0.00654)	<0.03 (---)	<0.03 (---)
DOC	170.0 (3.279)	104.5 (0.4330)	65.4 (0.1635)	43.3 (1.004)	34.2 (0.2658)

Table B27

Metal and DOC Solid Phase Concentrations in Sequential Batch Leach Tests
for 0.3 STC Processed Hot-Spot Sediment, mg/kg*

<u>Contaminant</u>	<u>Step Number</u>				
	<u>1</u>	<u>2</u>	<u>3</u>	<u>4</u>	<u>5</u>
Cadmium	17.232	17.231	17.231	17.231	17.231
Chromium	279.247	279.112	278.944	278.755	278.537
Copper	590.681	584.425	580.026	576.456	573.702
Lead	344.655	344.647	344.640	344.634	344.634
Nickel	43.401	42.803	42.500	42.332	42.231
Zinc	1,553.257	1,553.180	1,553.061	1,553.061	1,553.061
DOC	11,945.3	11,720.1	11,579.3	11,486.0	11,412.5

* Calculated using Equation 3.

Table B28
 Leachate PCB Concentrations in Sequential Batch Leach Tests for 0.3 STC
 Processed Midrange Sediments, mg/L (Standard Error)

PCB Parameter	Step Number				
	1	2	3	4	5
Aroclor 1016	<0.0001 (--)	<0.0001 (--)	<0.0001 (--)	<0.0001 (--)	<0.0001 (--)
Aroclor 1221	<0.0001 (--)	<0.0001 (--)	<0.0001 (--)	<0.0001 (--)	<0.0001 (--)
Aroclor 1232	<0.0001 (--)	<0.0001 (--)	<0.0001 (--)	<0.0001 (--)	<0.0001 (--)
Aroclor 1242	0.0273 (0.00802)	0.0355 (0.00286)	0.0276 (0.0681)	0.0135 (0.00075)	0.0132 (0.00134)
Aroclor 1248	<0.0001 (--)	<0.0001 (--)	<0.0001 (--)	<0.0001 (--)	<0.0001 (--)
Aroclor 1254	0.00175 (0.000485)	0.00228 (0.000288)	0.00155 (0.00043)	0.00195 (0.00227)	0.00177 (0.000358)
Aroclor 1260	<0.0001 (--)	<0.0001 (--)	<0.0001 (--)	<0.0001 (--)	<0.0001 (--)
Total PCBs	0.325 (0.00961)	0.0430 (0.00212)	0.0288 (0.00690)	0.0143 (0.000819)	0.0143 (0.00163)
C7	0.00001 (0.000001)	0.00001 (0.000001)	0.00001 (0.000001)	0.000017 (0.000002)	0.000022 (0.000002)
C8	0.00110 (0.000672)	0.00220 (0.000252)	0.0042 (0.00101)	0.00185 (0.000182)	0.00465 (0.000238)
C28	0.00158 (0.000538)	0.00248 (0.000073)	0.00195 (0.000535)	0.00107 (0.000093)	0.00188 (0.00027)
C44	0.000086 (0.000039)	0.000207 (0.000044)	0.000332 (0.00007)	0.00043 (0.000018)	0.000435 (0.000052)
C49	0.000082 (0.000013)	0.000041 (0.000012)	0.000067 (0.000016)	0.00014 (0.000006)	0.00014 (0.000014)
C50	0.00110 (0.000388)	0.00122 (0.000226)	0.00150 (0.000448)	0.00103 (0.00005)	0.00111 (0.000149)
C52	0.000385 (0.000223)	0.000651 (0.000189)	0.00091 (0.000223)	0.000217 (0.000106)	0.00106 (0.000118)
C70	0.000047 (0.000012)	0.000082 (0.000011)	0.000165 (0.000046)	0.000237 (0.000041)	0.000047 (0.000012)
C77	0.000068 (0.000055)	<0.0001 (--)	0.000342 (0.000076)	0.000217 (0.000106)	0.00048 (0.000086)
C82	0.000042 (0.000031)	0.000011 (0.000005)	0.000013 (0.000007)	<0.0001 (--)	<0.0001 (--)
C87	0.00001 (0.000003)	0.000013 (0.000007)	0.00005 (0.000012)	0.000047 (0.000009)	0.000057 (0.000015)
C97	0.000031 (0.00008)	0.000032 (0.000008)	0.000082 (0.000023)	0.000082 (0.000008)	0.000085 (0.00002)
C101	0.00004 (0.000019)	0.000077 (0.000022)	0.000207 (0.000061)	0.00023 (0.000029)	0.000237 (0.00005)
C105	0.000013 (0.000007)	<0.0001 (--)	<0.0001 (--)	0.00004 (0.000006)	0.000048 (0.000016)
C118	0.000017 (0.000006)	0.000032 (0.000009)	0.000058 (0.00002)	0.00009 (0.000012)	0.000085 (0.000016)
C136	<0.0001 (--)	<0.0001 (--)	0.000228 (0.000165)	0.000027 (0.000004)	<0.0001 (--)
C138	0.00001 (0.000001)	<0.0001 (--)	0.000037 (0.000012)	0.000057 (0.000007)	0.00007 (0.000018)
C143	<0.0001 (--)	<0.0001 (--)	<0.0001 (--)	0.000011 (0.000005)	0.000026 (0.000009)
C153	0.00001 (0.000003)	0.000025 (0.000007)	0.000077 (0.000019)	0.000077 (0.000011)	0.000077 (0.000017)
C155	0.000031 (0.000022)	<0.0001 (--)	0.000016 (0.000009)	0.000205 (0.000026)	0.00022 (0.000048)
C167	0.000018 (0.000011)	<0.0001 (--)	<0.0001 (--)	0.00001 (0.000003)	<0.0001 (--)
C180	<0.00001 (--)	<0.00001 (--)	0.000013 (0.000004)	0.000017 (0.000004)	0.000013 (0.000004)
C185	<0.00001 (--)	<0.00001 (--)	0.00002 (0.000007)	<0.0001 (--)	<0.0001 (--)

Table B29

Solid Phase PCB Concentrations in Sequential Batch Leach Test for
0.3 STC Processed Midrange Sediment, mg/kg*

PCB Parameter	Step Number			
	1	2	3	4
Aroclor 1016	<20	<20	<20	<20
Aroclor 1221	<20	<20	<20	<20
Aroclor 1232	<20	<20	<20	<20
Aroclor 1242	782.9391	782.8598	782.7981	782.7680
Aroclor 1248	<20	<20	<20	<20
Aroclor 1254	311.6627	311.6576	311.6542	311.6498
Aroclor 1260	<20	<20	<20	<20
Total PCBs	1,096.927	1,096.831	1,096.767	1,096.735
C7	0.2567	0.2567	0.2567	0.2566
C8	79.3310	79.3260	79.3170	79.3120
C28	133.3298	133.3242	133.3199	133.3175
C44	29.9998	29.9993	29.9986	29.9976
C49	13.6665	13.6664	13.6662	13.6659
C50	55.9975	55.9948	55.9915	55.9892
C52	81.3325	81.3310	81.3290	81.3285
C70	23.3332	23.3330	23.3327	23.3321
C77	105.6665	105.6665	105.6657	105.6652
C82	<0.01	<0.01	<0.01	<0.01
C87	11.5333	11.5333	11.5332	11.5331
C97	23.6666	23.6665	23.6663	23.6662
C101	36.9999	36.9997	36.9993	36.9988
C105	5.4333	5.4333	5.4333	5.4332
C118	18.6666	18.6666	18.6664	18.6662
C136	9.1667	9.1667	9.1662	9.1661
C138	12.3333	12.3333	12.3332	12.3331
C143	7.0667	7.0667	7.0667	7.0666
C153	20.3333	20.3333	20.3331	20.3329
C155	<0.01	<0.01	<0.01	<0.01
C167	<0.01	<0.01	<0.01	<0.01
C180	2.7667	2.7667	2.7666	2.7666
C185	3.4050	3.4050	3.4049	3.4049

* Calculated using Equation 3.

Table B30
 Leachate PCB Concentrations in Sequential Batch Leach Test for 0.3 STC
 Processed Hot-Spot Sediment, mg/L (Standard Error)

PCB Parameter	Step Number				
	1	2	3	4	5
Aroclor 1016	<0.0001 (--)	<0.0001 (--)	<0.0001 (--)	<0.0001 (--)	<0.0001 (--)
Aroclor 1221	<0.0001 (--)	<0.0001 (--)	<0.0001 (--)	<0.0001 (--)	<0.0001 (--)
Aroclor 1232	<0.0001 (--)	<0.0001 (--)	<0.0001 (--)	<0.0001 (--)	<0.0001 (--)
Aroclor 1242	0.123 (0.002165)	0.0285 (0.000559)	0.0119 (0.0117)	0.150 (0.0154)	0.0485 (0.00807)
Aroclor 1248	<0.0001 (--)	<0.0001 (--)	<0.0001 (--)	<0.0001 (--)	<0.0001 (--)
Aroclor 1254	0.00643 (0.000207)	0.00313 (0.0000810)	0.00408 (0.000717)	0.00628 (0.000255)	0.00438 (0.00142)
Aroclor 1260	<0.0001 (--)	<0.0001 (--)	<0.0001 (--)	<0.0001 (--)	<0.0001 (--)
Total PCBs	0.130 (--)	0.0330 (0.000707)	0.153 (0.0188)	0.167 (0.0253)	0.0625 (0.00344)
C7	0.000032 (0.000004)	0.000075 (0.000002)	0.000057 (0.000008)	0.000025 (0.000002)	0.00007 (0.000003)
C8	0.0208 (0.000216)	0.0180 (0.000353)	0.0208 (0.00143)	0.0180 (0.000707)	0.0118 (0.00239)
C28	0.00825 (0.000134)	0.00603 (0.000155)	0.00988 (0.000629)	0.00838 (0.000324)	0.00638 (0.000411)
C44	0.00130 (0.000061)	0.00188 (0.000324)	0.00315 (0.000427)	0.00085 (0.0000860)	0.00150 (0.000206)
C49	0.000165 (0.000002)	0.000385 (0.0000140)	0.000392 (0.0000540)	0.000165 (0.000007)	0.000397 (0.000021)
C50	0.0150 (0.000756)	0.00425 (0.00009)	0.00785 (0.00119)	0.00291 (0.00146)	0.00433 (0.000276)
C52	0.00248 (0.000041)	0.00215 (0.00016)	0.00385 (0.000453)	0.000575 (0.000264)	0.00293 (0.000253)
C70	0.000575 (0.000012)	0.00137 (0.000392)	0.000882 (0.000124)	0.000555 (0.000026)	0.00103 (0.000139)
C77	0.000587 (0.000018)	<0.00001 (--)	0.000667 (0.000017)	<0.00001 (--)	0.00136 (0.000233)
C82	0.000016 (0.00003)	<0.00001 (--)	0.000087 (0.0021)	0.000042 (0.000002)	0.000021 (0.000014)
C87	0.000037 (0.000002)	0.00102 (0.000861)	0.000073 (0.000028)	0.000092 (0.000002)	0.000115 (0.000055)
C97	0.00013 (0.000008)	0.00242 (0.00166)	0.000182 (0.000052)	0.000133 (0.000039)	0.000262 (0.000039)
C101	0.000387 (0.00001)	0.000797 (0.000378)	0.00212 (0.000963)	0.00049 (0.000032)	0.000732 (0.000131)
C105	<0.00001 (--)	0.000066 (0.000053)	<0.00001 (--)	0.00006 (0.00002)	<0.00001 (--)
C118	0.000077 (0.000008)	0.00025 (0.000043)	0.00016 (0.000006)	0.000047 (0.000004)	0.000272 (0.000064)
C136	<0.00001 (--)	0.000068 (0.000055)	0.000077 (0.000022)	<0.00001 (--)	0.000048 (0.000037)
C138	0.00003 (0.000006)	0.000046 (0.000035)	0.000035 (0.000005)	0.000025 (0.000004)	0.000402 (0.000265)
C143	<0.00001 (--)	0.000031 (0.000022)	0.00003 (0.000014)	<0.00001 (--)	<0.00001 (--)
C153	0.000067 (0.000014)	0.00009 (0.000046)	<0.00001 (--)	0.000132 (0.000022)	0.000657 (0.000504)
C155	<0.00001 (--)	0.00054 (0.000278)	<0.00001 (--)	0.000311 (0.000099)	0.000523 (0.000189)
C167	<0.00001 (--)	0.000165 (0.000074)	0.000011 (0.000005)	0.000078 (0.000063)	0.000453 (0.000388)
C180	<0.00001 (--)	0.000028 (0.00002)	0.000025 (0.000004)	0.000012 (0.000002)	<0.00001 (--)
C185	<0.00001 (--)	<0.00001 (--)	<0.00001 (--)	<0.00001 (--)	<0.00001 (--)

Table B31

Solid Phase PCB Concentrations in Sequential Batch Leach Test for
0.3 STC Processed Hot-Spot Sediment, mg/kg*

PCB Parameter	Step Number			
	1	2	3	4
Aroclor 1016	<20	<20	<20	<20
Aroclor 1221	<20	<20	<20	<20
Aroclor 1232	<20	<20	<20	<20
Aroclor 1242	2,633.069	2,633.008	2,632.751	2,632.428
Aroclor 1248	<20	<20	<20	<20
Aroclor 1254	798.3194	798.3127	798.3039	798.2904
Aroclor 1260	<20	<20	<20	<20
Total PCBs	3,766.386	3,766.315	3,765.987	3,765.627
C7	0.7866	0.7864	0.7863	0.7863
C8	239.9550	239.9150	239.8718	239.8330
C28	393.3155	393.3025	393.2813	393.2632
C44	108.3305	108.3264	108.3197	108.3178
C49	32.6663	32.6655	32.6646	32.6643
C50	170.9677	170.9585	170.9416	170.9354
C52	190.9946	190.9900	190.9817	190.9805
C70	122.9987	122.9958	122.9939	122.9927
C77	372.6654	372.6654	372.6639	372.6639
C82	<0.01	<0.01	<0.01	<0.01
C87	41.3333	41.3311	41.3309	41.3307
C97	91.3331	91.3279	91.3275	91.3272
C101	139.9991	139.9974	139.9928	139.9918
C105	13.5000	13.4999	13.4999	13.4997
C118	71.6665	71.6660	71.6656	71.6655
C136	36.6666	36.6665	36.6663	36.6663
C138	23.3333	23.3332	23.3331	23.3330
C143	17.3333	17.3333	17.3320	17.3320
C153	40.6665	40.6663	40.6663	40.6660
C155	<0.01	<0.01	<0.01	<0.01
C167	10.4333	10.4330	10.4330	10.4328
C180	3.6000	3.5999	3.5999	3.5999
C185	0.8683	0.8683	0.8683	0.8683

* Calculated using Equation 3.

Table B32

Leachate PCB Concentrations in Sequential Batch Leach Test for 0.3 Portland Cement
Processed Hot-Spot Sediment, mg/L (Standard Error)

PCB Parameter	Step Number			
	1	2	3	4
Aroclor 1016	<0.0001 (--)	<0.0001 (--)	<0.0001 (--)	<0.0001 (--)
Aroclor 1221	<0.0001 (--)	<0.0001 (--)	<0.0001 (--)	<0.0001 (--)
Aroclor 1232	<0.0001 (--)	<0.0001 (--)	<0.0001 (--)	<0.0001 (--)
Aroclor 1242	0.198 (0.00892)	0.0353 (0.00188)	0.118 (0.00415)	0.145 (0.00901)
Aroclor 1248	<0.0001 (--)	<0.0001 (--)	<0.0001 (--)	<0.0001 (--)
Aroclor 1254	0.0055 (0.000437)	0.00325 (0.000152)	0.00095 (0.000256)	0.00705 (0.000325)
Aroclor 1260	<0.0001 (--)	<0.0001 (--)	<0.0001 (--)	<0.0001 (--)
Total PCBs	0.21 (0.00707)	0.0398 (0.00227)	0.143 (0.00650)	0.130 (0.00612)
C7	0.000057 (0.000002)	0.000112 (0.000006)	0.000052 (0.000004)	0.000047 (0.000007)
C8	0.0333 (0.0037)	0.0295 (0.00109)	0.0313 (0.00114)	0.0180 (0.00184)
C28	0.0101 (0.000672)	0.00653 (0.00032)	0.00955 (0.000476)	0.00918 (0.0049)
C44	0.00153 (0.000108)	0.00183 (0.000073)	0.00163 (0.000054)	0.00135 (0.00009)
C49	0.00018 (0.000009)	0.000392 (0.000041)	0.00023 (0.00001)	0.000157 (0.000012)
C50	0.00915 (0.000363)	0.0048 (0.000247)	0.00835 (0.000313)	0.00545 (0.00162)
C52	0.00265 (0.000201)	0.0249 (0.0199)	0.00238 (0.000073)	0.0023 (0.000162)
C70	0.00057 (0.000036)	0.00094 (0.000058)	0.000507 (0.000019)	0.000565 (0.000041)
C77	0.000595 (0.000041)	<0.00001 (--)	0.000362 (0.000096)	0.000375 (0.000186)
C82	0.000025 (0.000002)	<0.00001 (--)	0.00001 (0.000003)	0.000045 (0.000005)
C87	0.000035 (0.000002)	0.00004 (0.000017)	0.00001 (0.000003)	0.000045 (0.000005)
C97	0.000155 (0.000014)	0.000155 (0.000002)	0.000085 (0.000012)	0.000187 (0.000016)
C101	0.00037 (0.000031)	0.000208 (0.000059)	0.000202 (0.000034)	0.000492 (0.000049)
C105	<0.00001 (--)	<0.00001 (--)	<0.00001 (--)	0.000033 (0.000009)
C118	0.000077 (0.000005)	0.000152 (0.000009)	0.00006 (0.000009)	0.000063 (0.000019)
C136	0.00001 (0.000001)	0.00138 (0.000686)	0.000031 (0.000009)	0.000045 (0.000021)
C138	0.000035 (0.000004)	0.000703 (0.000605)	0.00001 (0.000001)	0.000031 (0.00001)
C143	<0.00001 (--)	0.000303 (0.000258)	0.00001 (0.000001)	0.000016 (0.000009)
C153	0.00006 (0.000001)	0.000725 (0.000599)	<0.00001 (--)	0.000082 (0.000022)
C155	<0.00001 (--)	0.000158 (0.000046)	<0.00001 (--)	0.000477 (0.000033)
C167	<0.00001 (--)	<0.00001 (--)	<0.00001 (--)	0.000052 (0.000026)
C180	0.00001 (0.000001)	0.000123 (0.000102)	<0.00001 (--)	0.000013 (0.000004)
C185	<0.00001 (--)	<0.00001 (--)	<0.00001 (--)	<0.00001 (--)

Table B33

Solid Phase PCB Concentrations in Sequential Batch Leach Test for
0.3 Portland Cement Processed Hot-Spot Sediment, mg/kg*

PCB Parameter	Step Number			
	1	2	3	4
Aroclor 1016	<20	<20	<20	<20
Aroclor 1221	<20	<20	<20	<20
Aroclor 1232	<20	<20	<20	<20
Aroclor 1242	1,882.853	1,882.767	1,882.481	1,882.129
Aroclor 1248	<20	<20	<20	<20
Aroclor 1254	1,383.319	1,383.312	1,383.309	1,383.292
Aroclor 1260	<20	<20	<20	<20
Total PCBs	3,282.822	3,282.726	3,282.379	3,282.063
C7	1.0632	1.0622	11.0628	1.0627
C8	139.2524	139.1807	139.1047	139.0610
C28	140.3088	140.2930	140.2698	140.2475
C44	61.3296	61.3252	61.3212	61.3180
C49	28.3329	28.3319	28.3314	28.3310
C50	64.9778	64.9661	64.9458	64.9325
C52	133.3268	133.2662	133.2605	133.2549
C70	65.9986	65.9963	65.9951	65.9937
C77	316.6652	316.6652	316.6643	316.6634
C82	<0.01	<0.01	<0.01	<0.01
C87	83.9999	83.9998	83.9998	83.9997
C97	188.3329	188.3325	188.3323	188.3319
C101	79.9991	79.9986	79.9981	79.9969
C105	9.3667	9.3667	9.3667	9.3666
C118	102.3331	102.3327	102.3326	102.3324
C136	86.3333	86.3300	86.3299	86.3298
C138	58.6666	58.6649	58.6649	58.6648
C143	37.6667	37.6659	37.6659	37.6659
C153	115.3331	115.3314	115.3314	115.3312
C155	<0.01	<0.01	<0.01	<0.01
C167	25.0033	25.0033	25.0033	25.0032
C180	17.4667	17.4664	17.4663	17.4663
C185	<0.01	<0.01	<0.01	<0.01

* Calculated using Equation 3.

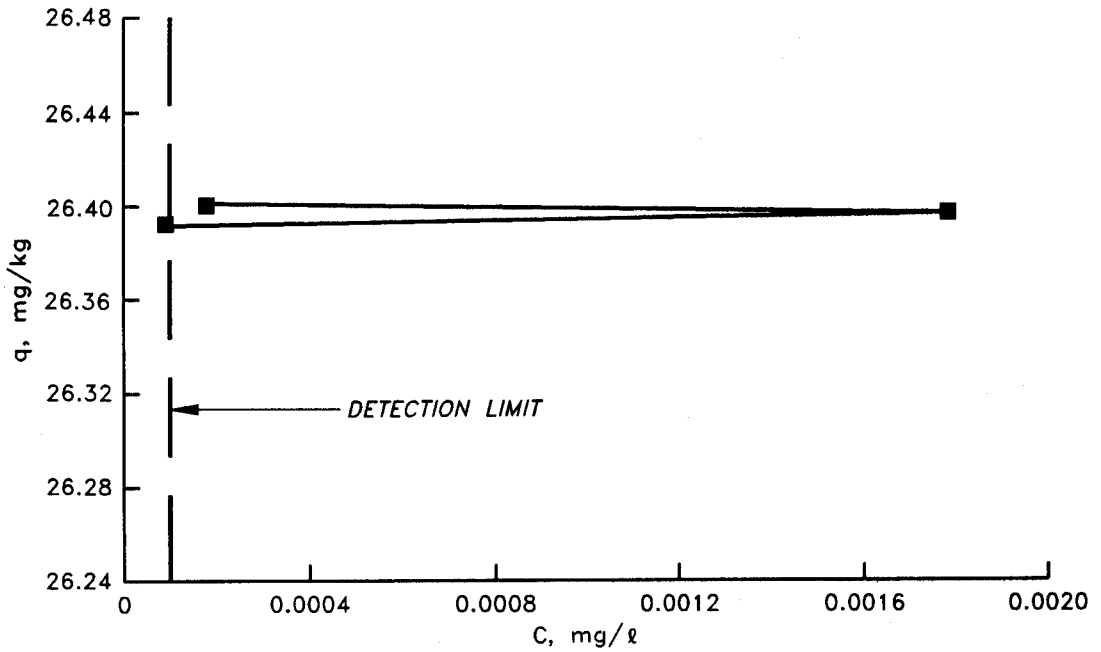

Figure B1. Cadmium desorption isotherm for midrange concentration composite sediment solidified/stabilized with 0.1 portland cement: 1.0 wet sediment

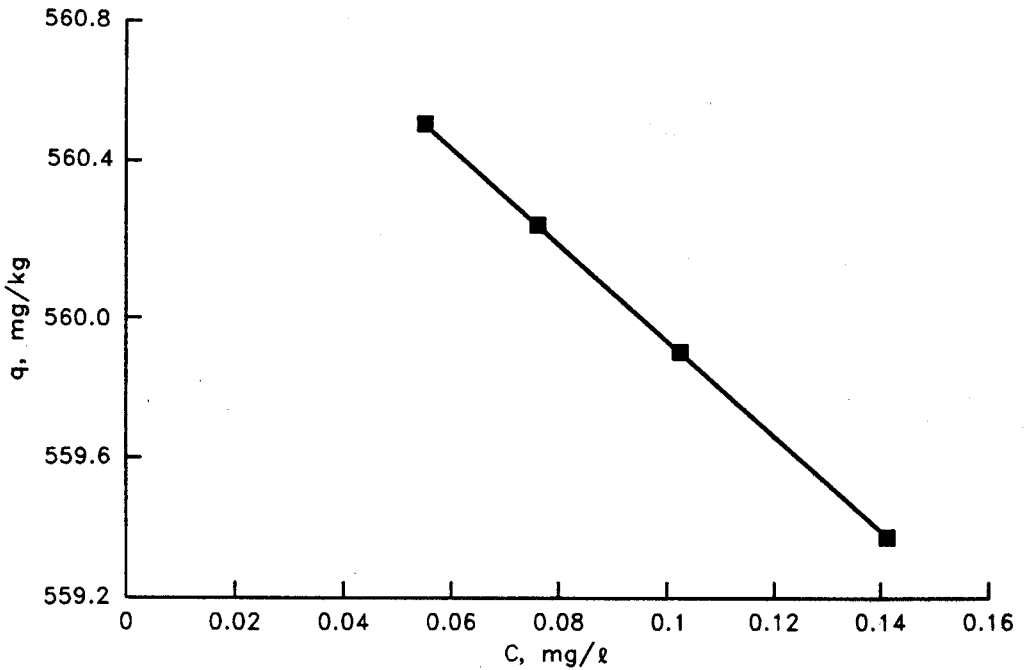

Figure B2. Chromium desorption isotherm for midrange concentration composite sediment solidified/stabilized with 0.1 portland cement: 1.0 wet sediment

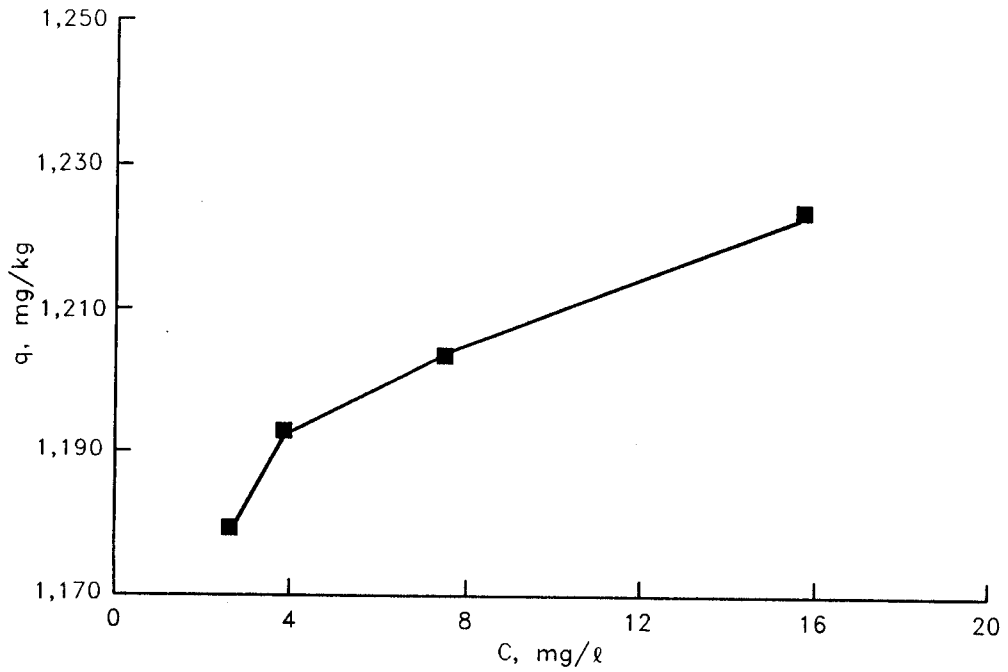

Figure B3. Copper desorption isotherm for midrange concentration composite sediment solidified/stabilized with 0.1 portland cement:1.0 wet sediment

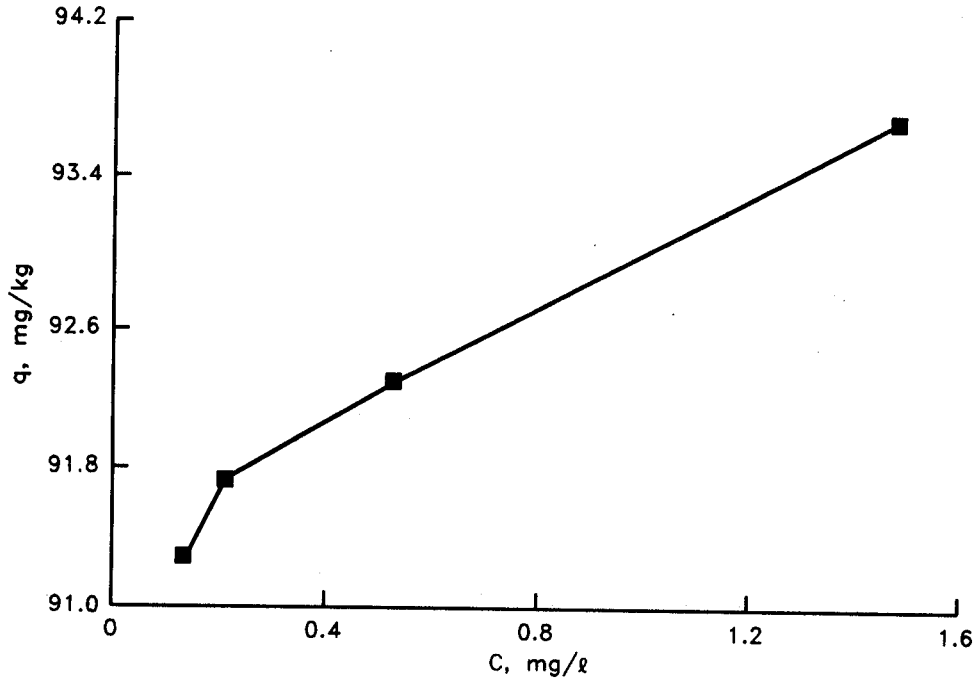

Figure B4. Nickel desorption isotherm for midrange concentration composite sediment solidified/stabilized with 0.1 portland cement:1.0 wet sediment

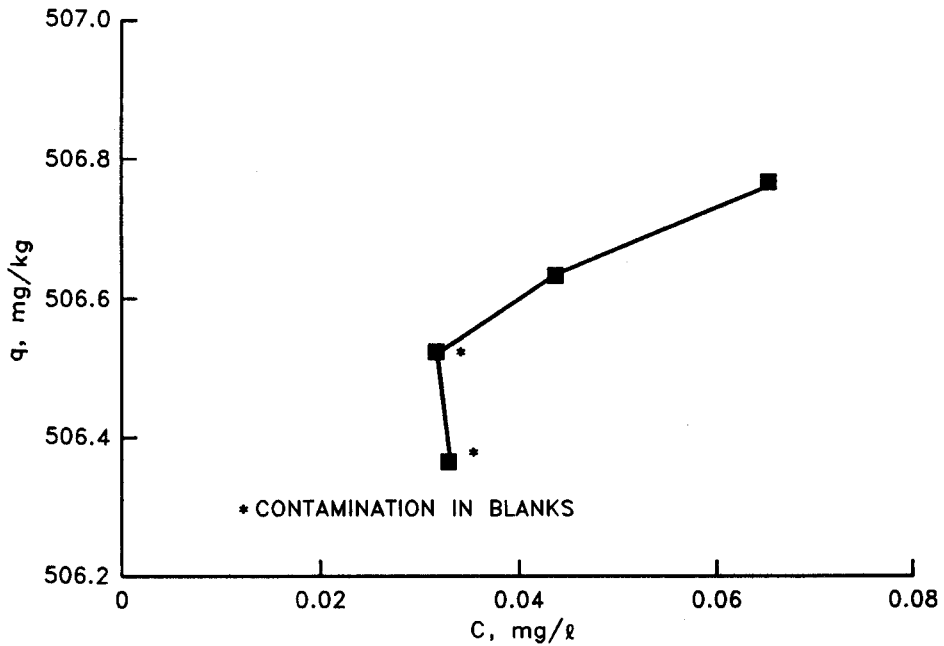

Figure B5. Lead desorption isotherm for midrange concentration composite sediment solidified/stabilized with 0.1 portland cement:1.0 wet sediment

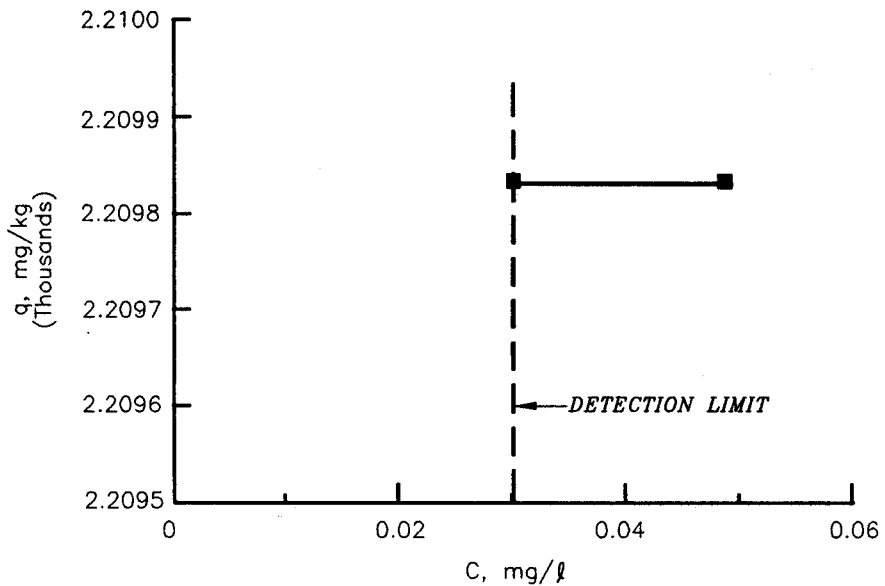

Figure B6. Zinc desorption isotherm for midrange concentration composite sediment solidified/stabilized with 0.1 portland cement:1.0 wet sediment

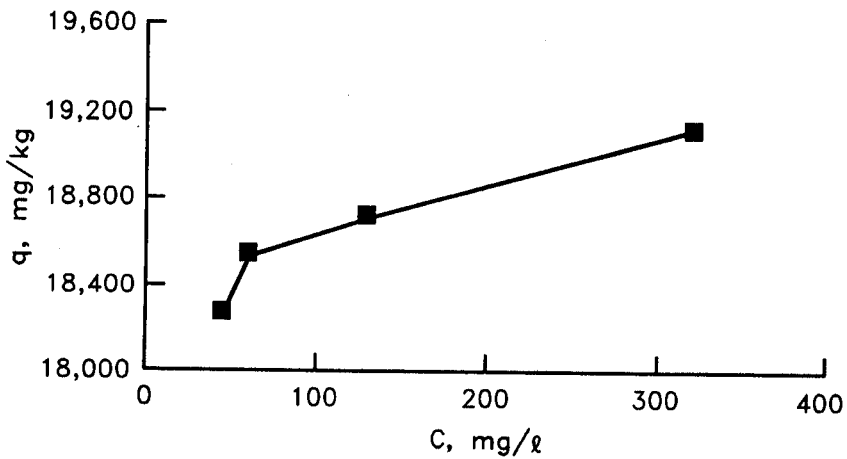

Figure B7. Dissolved organic carbon desorption isotherm for midrange concentration composite sediment solidified/stabilized with 0.1 portland cement: 1.0 wet sediment

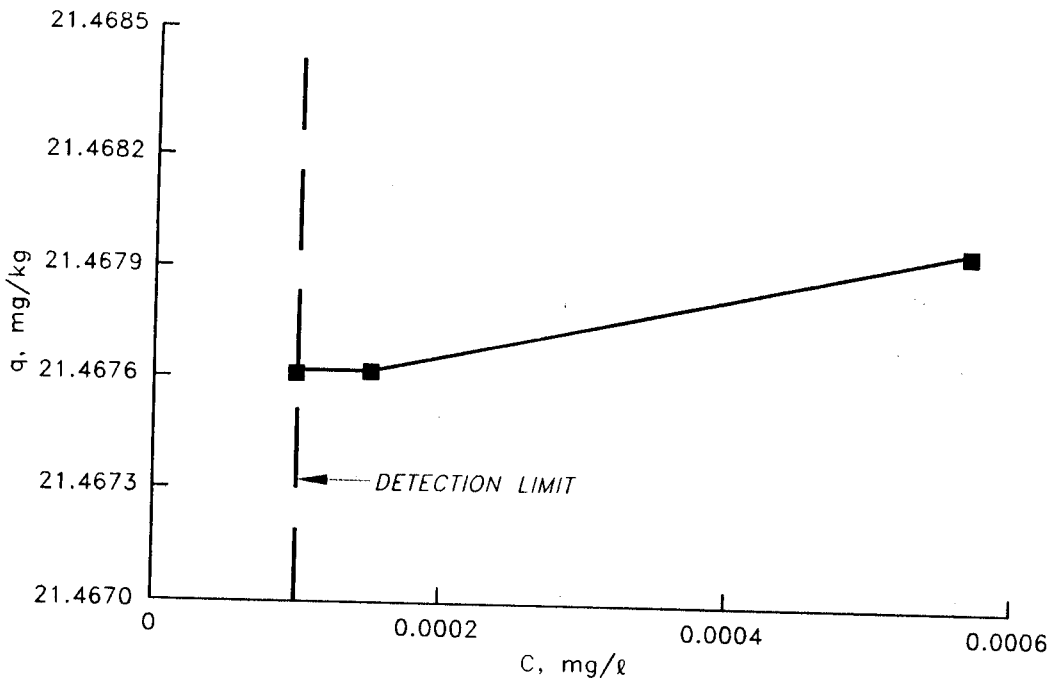

Figure B8. Cadmium desorption isotherm for midrange concentration composite sediment solidified/stabilized with 0.2 portland cement: 1.0 wet sediment

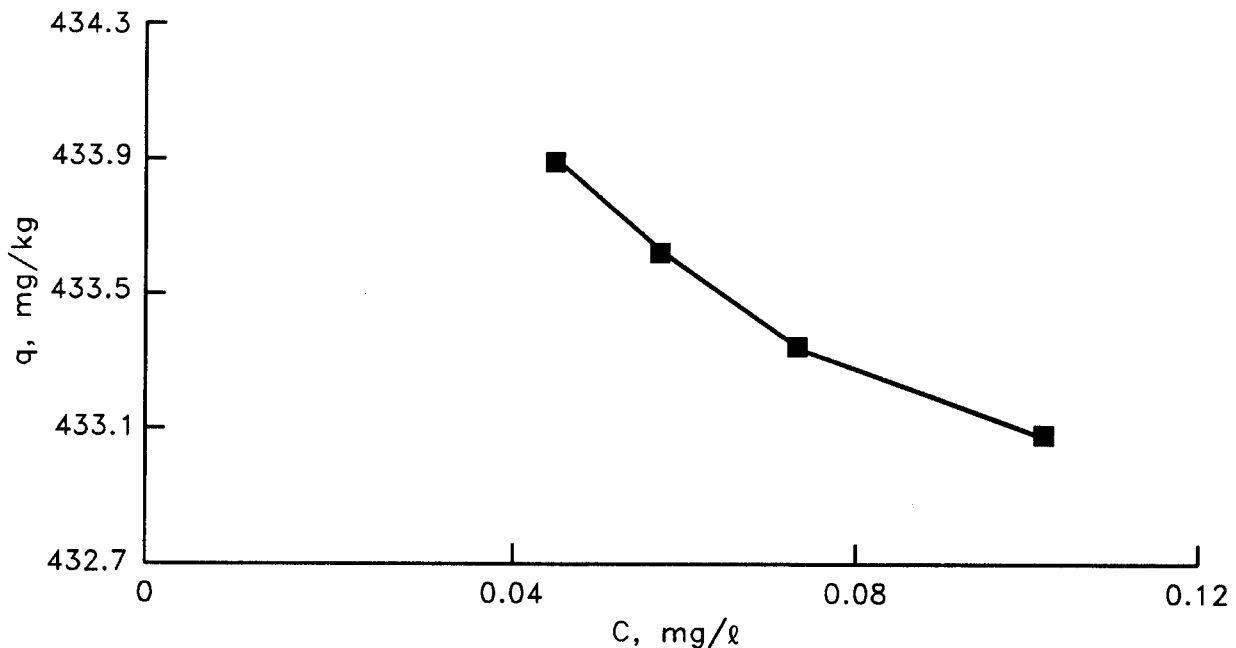

Figure B9. Chromium desorption isotherm for midrange concentration composite sediment solidified/stabilized with 0.2 portland cement:1.0 wet sediment

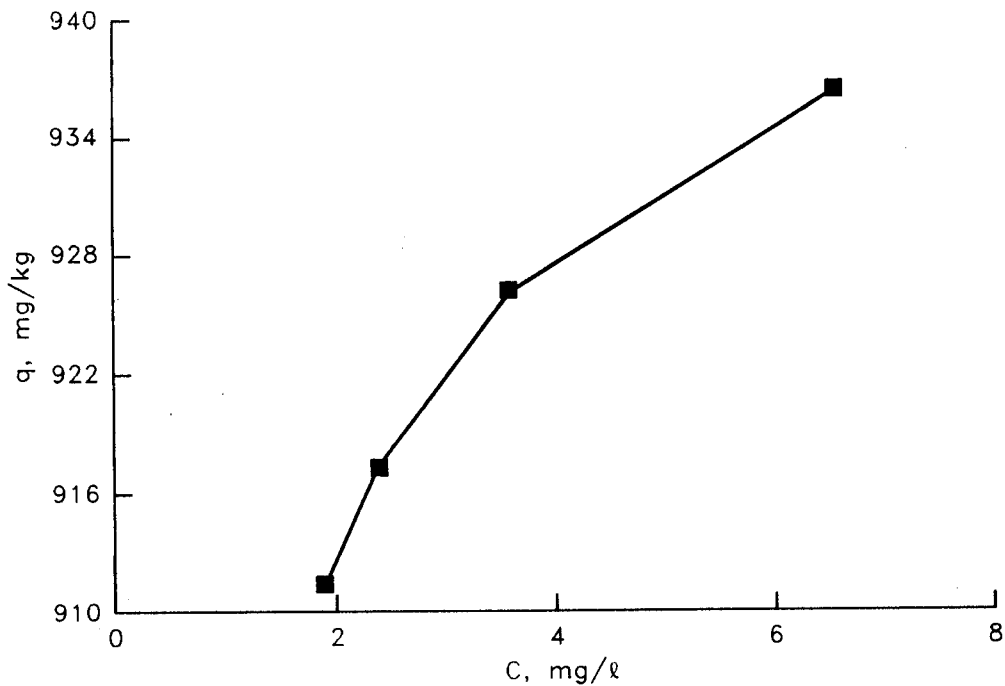

Figure B10. Copper desorption isotherm for midrange concentration composite sediment solidified/stabilized with 0.2 portland cement:1.0 wet sediment

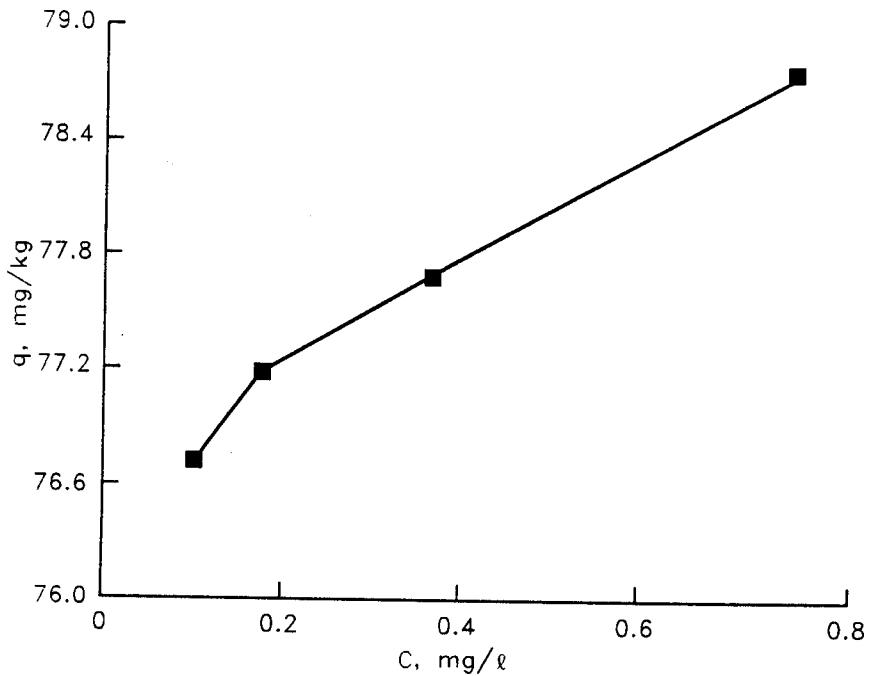

Figure B11. Nickel desorption isotherm for midrange concentration composite sediment solidified/stabilized with 0.2 portland cement:1.0 wet sediment

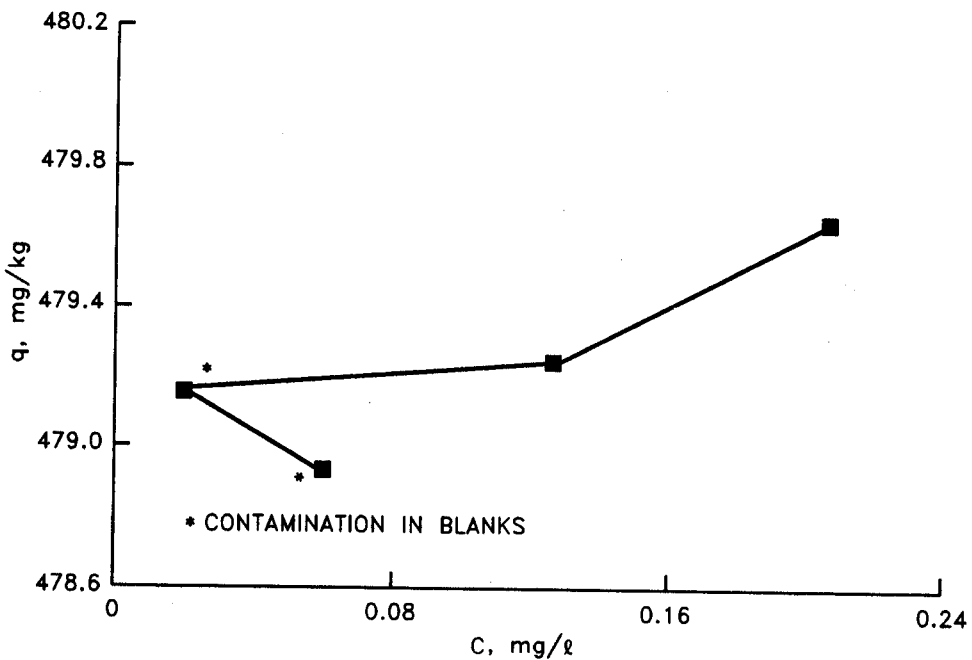

Figure B12. Lead desorption isotherm for midrange concentration composite sediment solidified/stabilized with 0.2 portland cement: 1.0 wet sediment

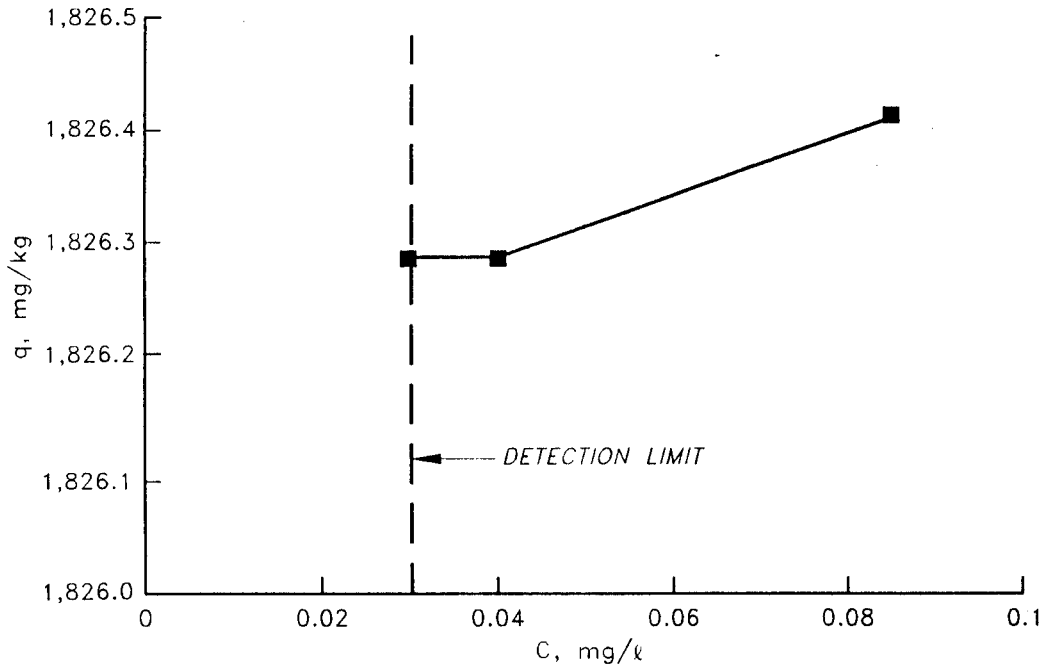

Figure B13. Zinc desorption isotherm for midrange concentration composite sediment solidified/stabilized with 0.2 portland cement: 1.0 wet sediment

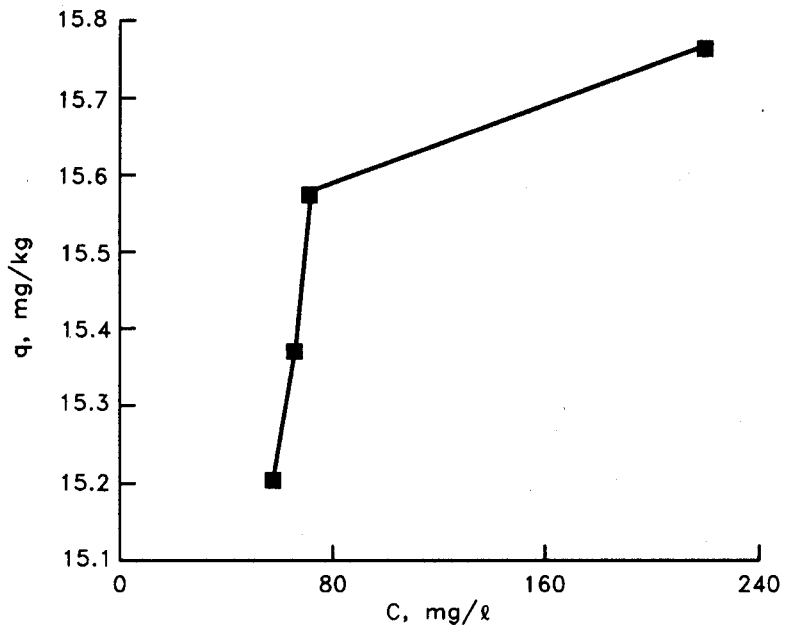

Figure B14. Dissolved organic carbon desorption isotherm for midrange concentration composite sediment solidified/stabilized with 0.2 portland cement: 1.0 wet sediment

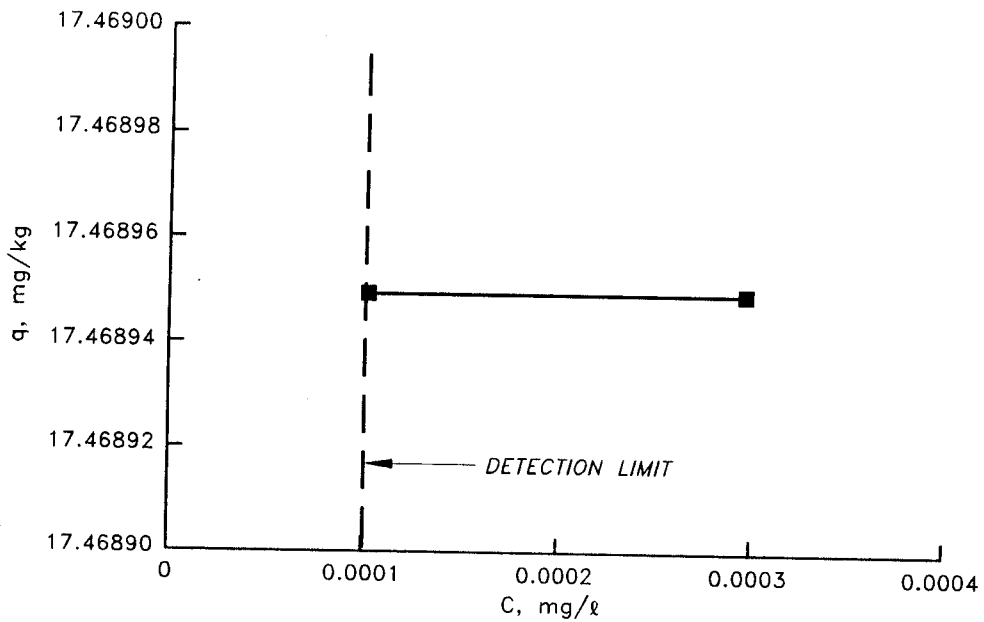

Figure B15. Cadmium desorption isotherm for midrange concentration composite sediment solidified/stabilized with 0.3 portland cement:1.0 wet sediment

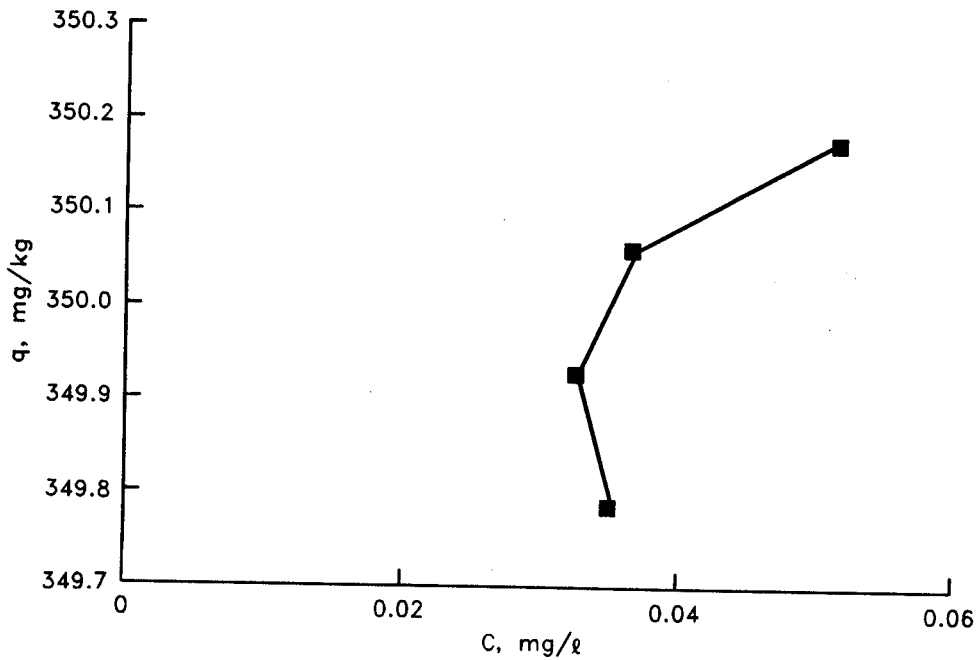

Figure B16. Chromium desorption isotherm for midrange concentration composite sediment solidified/stabilized with 0.3 portland cement:1.0 wet sediment

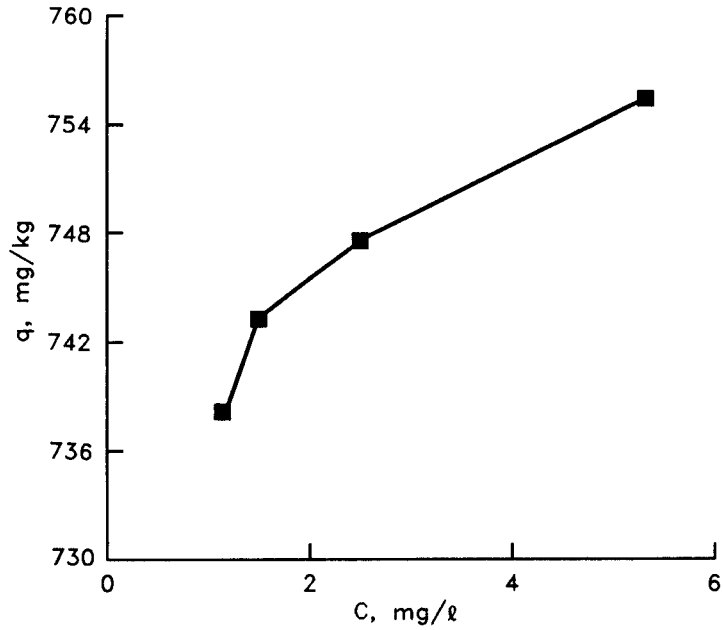

Figure B17. Copper desorption isotherm for midrange concentration composite sediment solidified/stabilized with 0.3 portland cement: 1.0 wet sediment

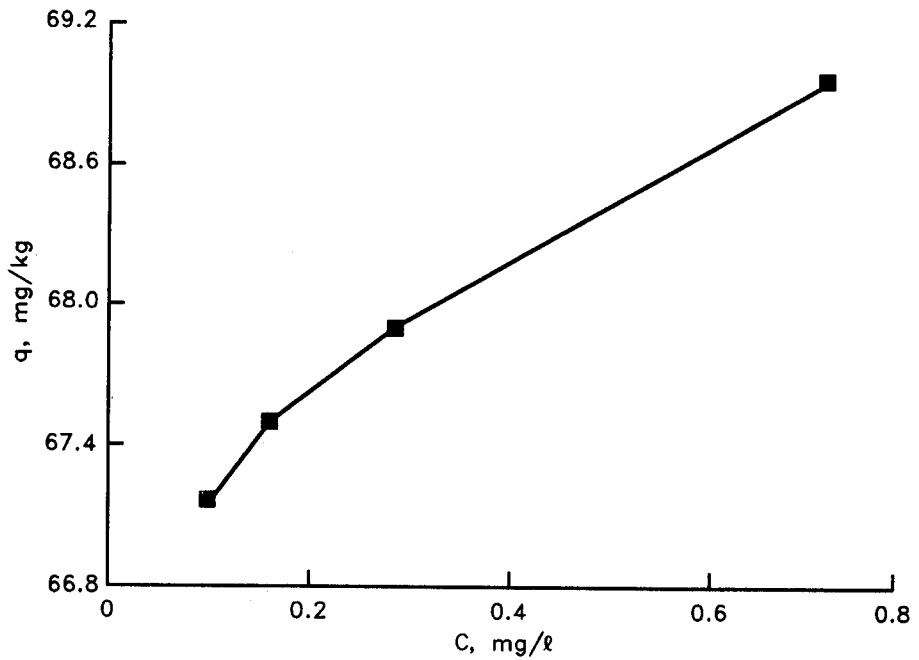

Figure B18. Nickel desorption isotherm for midrange concentration composite sediment solidified/stabilized with 0.3 portland cement: 1.0 wet sediment

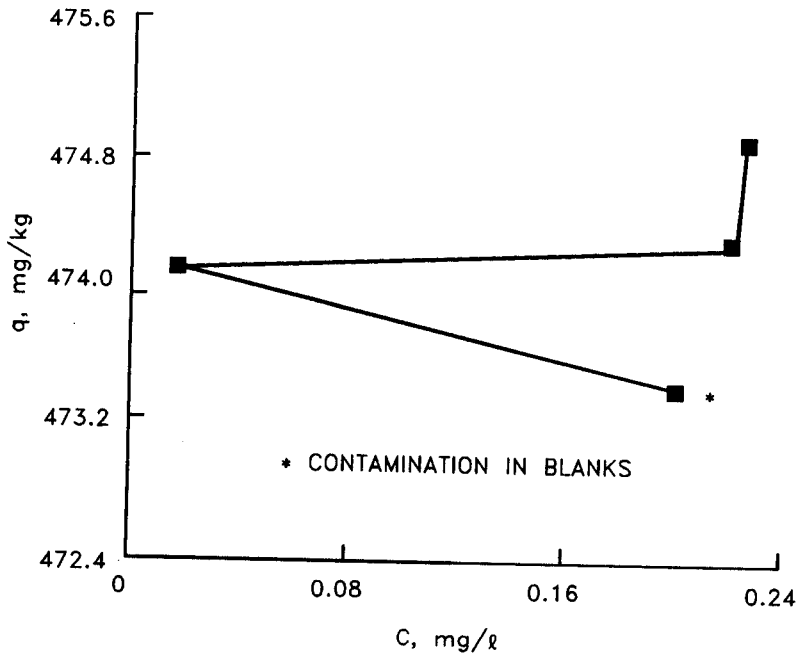

Figure B19. Lead desorption isotherm for midrange concentration composite sediment solidified/stabilized with 0.3 portland cement: 1.0 wet sediment

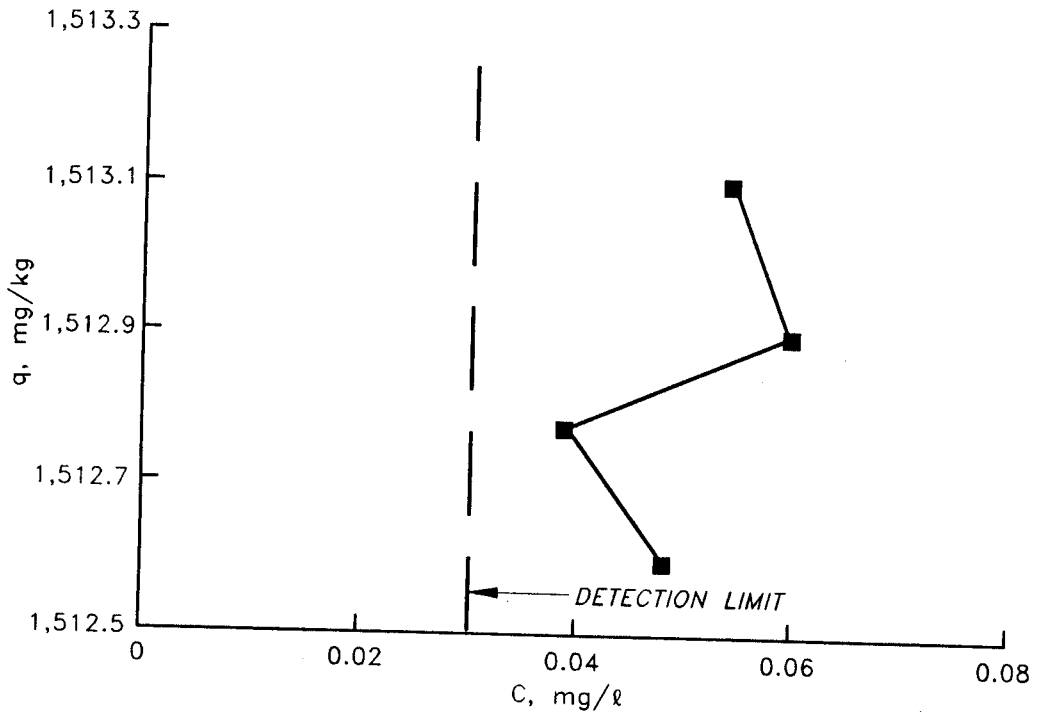

Figure B20. Zinc desorption isotherm for midrange concentration composite sediment solidified/stabilized with 0.3 portland cement: 1.0 wet sediment

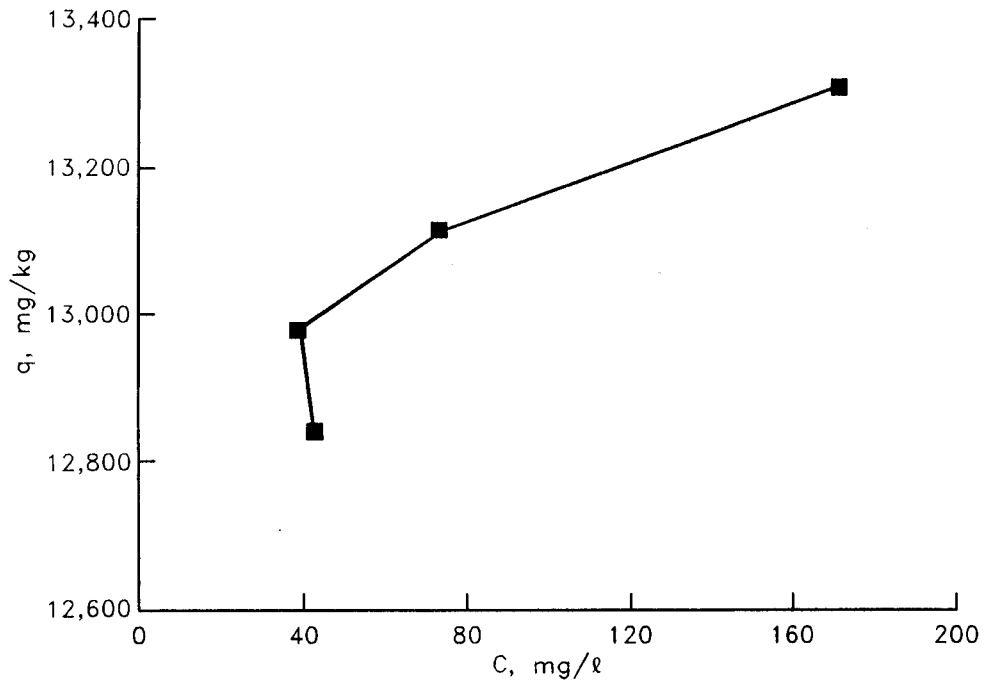

Figure B21. Dissolved organic carbon desorption isotherm for midrange concentration composite sediment solidified/stabilized with 0.3 portland cement: 1.0 wet sediment

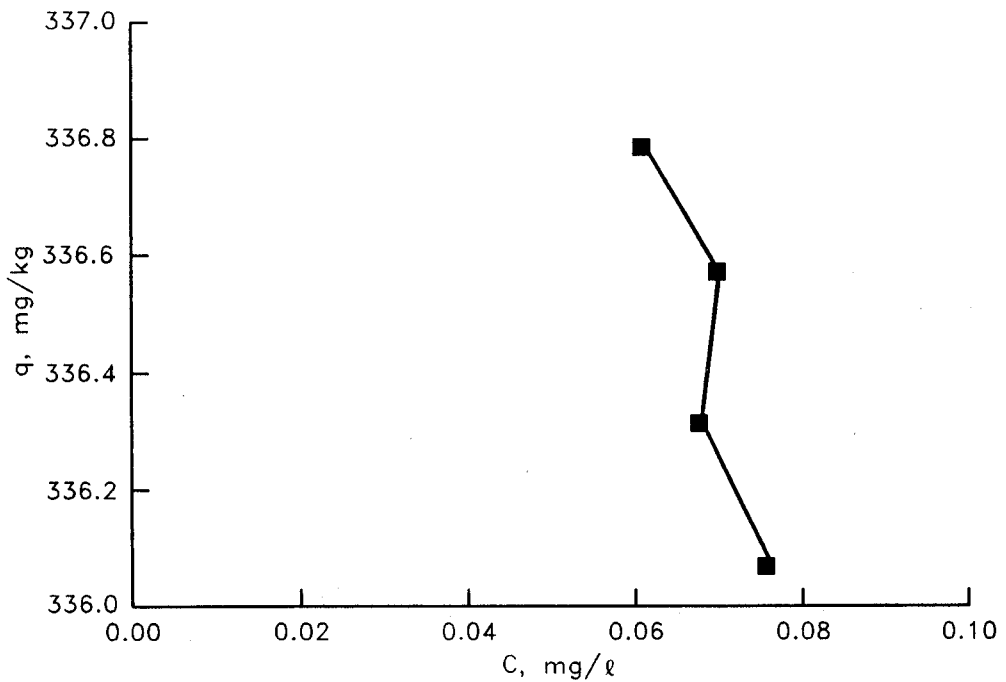

Figure B22. Chromium desorption isotherm for midrange concentration composite sediment solidified/stabilized with 0.2 portland cement: 0.1 Firmix: 1.0 wet sediment

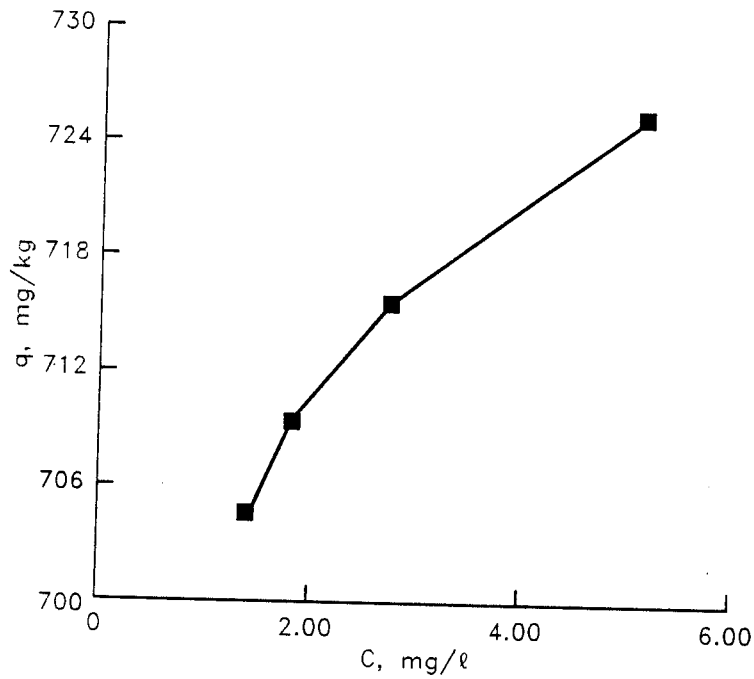

Figure B23. Copper desorption isotherm for midrange concentration composite sediment solidified/stabilized with 0.2 portland cement: 0.1 Firmix:1.0 wet sediment

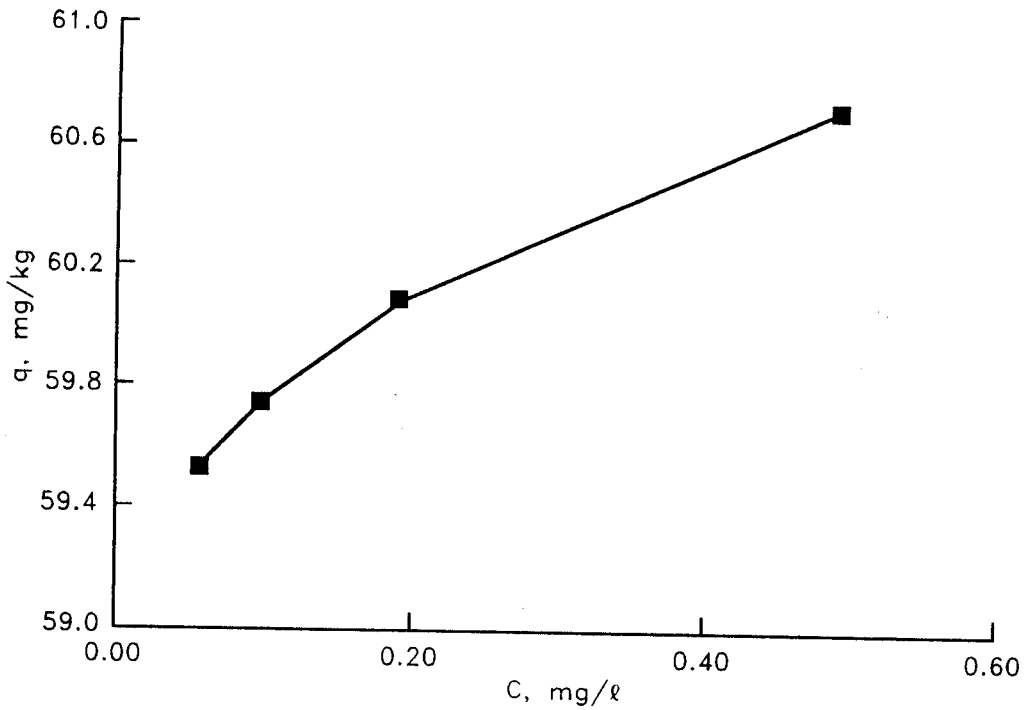

Figure B24. Nickel desorption isotherm for midrange concentration composite sediment solidified/stabilized with 0.2 portland cement:0.1 Firmix: 1.0 wet sediment

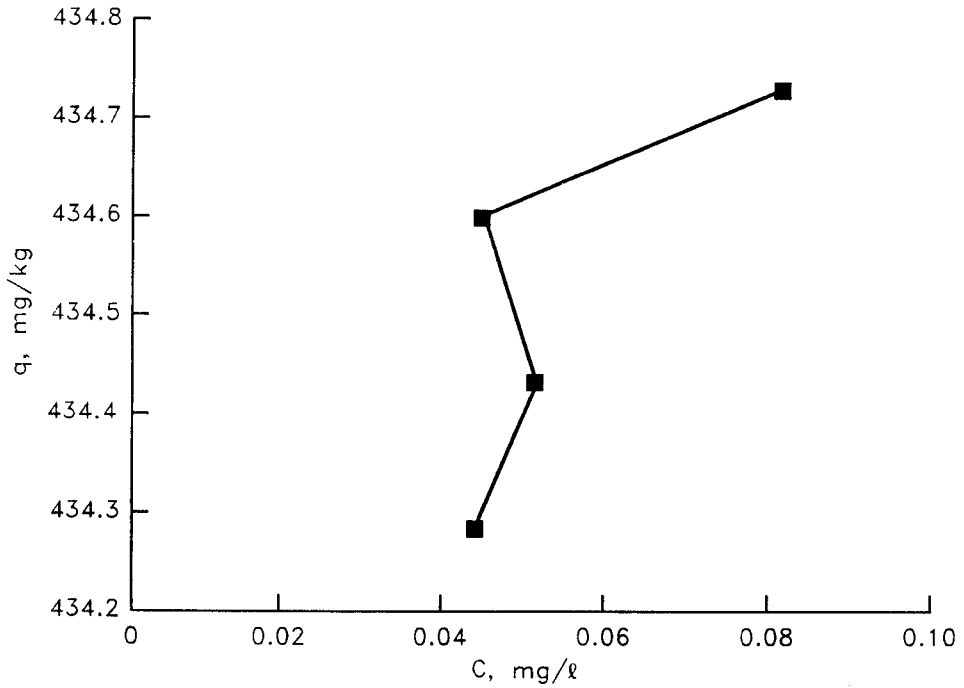

Figure B25. Lead desorption isotherm for midrange concentration composite sediment solidified/stabilized with 0.2 portland cement: 0.1 Firmix:1.0 wet sediment

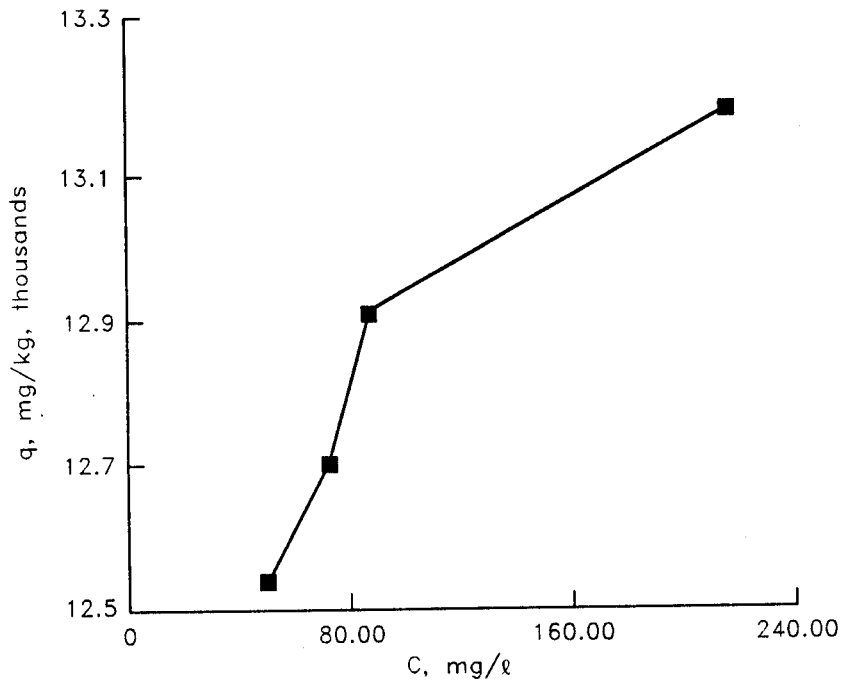

Figure B26. Dissolved organic carbon desorption isotherm for midrange concentration sediment solidified/stabilized with 0.2 portland cement: 0.1 Firmix:1.0 wet sediment

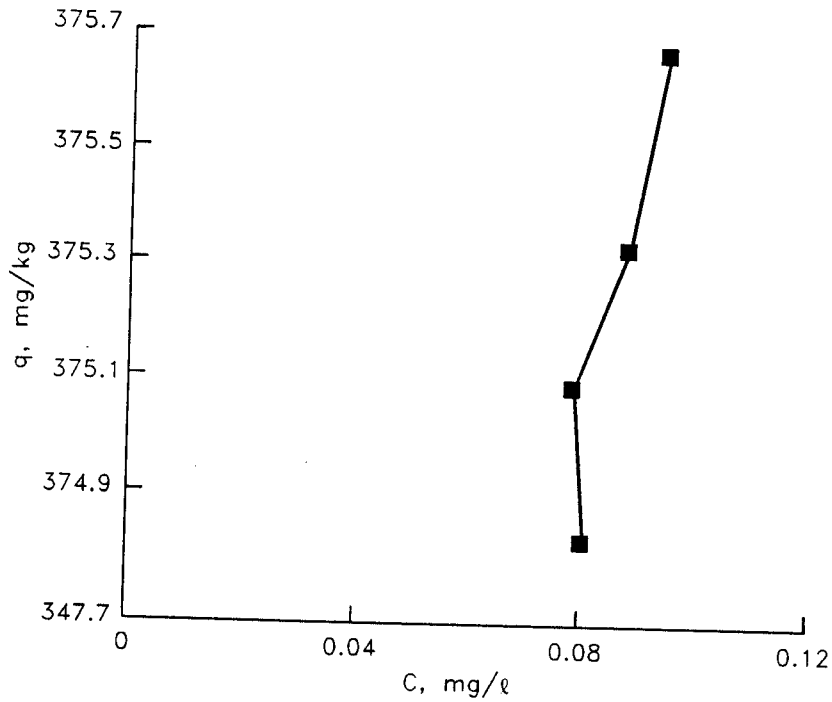

Figure B27. Chromium desorption isotherm for midrange concentration composite sediment solidified/stabilized with 0.15 portland cement:0.15 Firmix:1.0 wet sediment

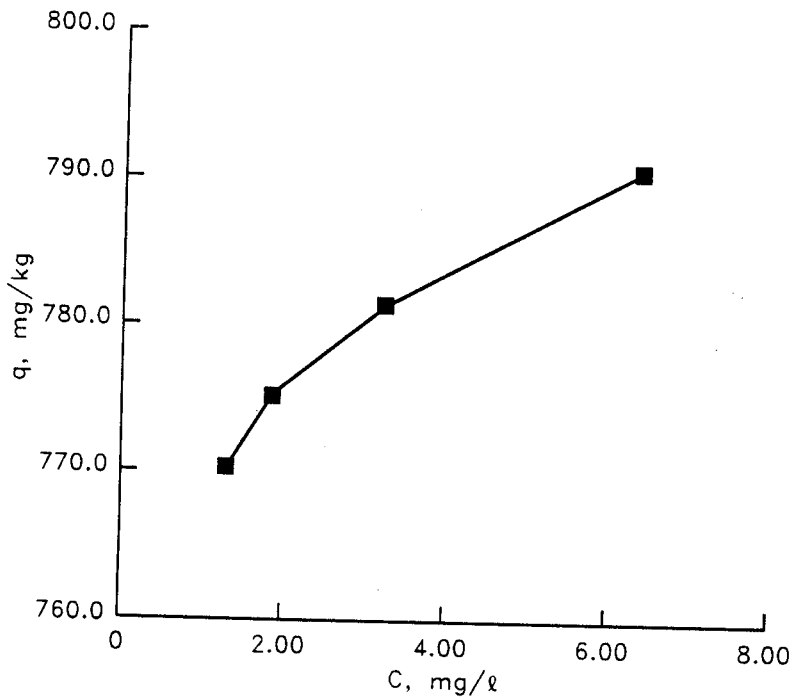

Figure B28. Copper desorption isotherm for midrange concentration composite sediment solidified/stabilized with 0.15 portland cement:0.15 Firmix:1.0 wet sediment

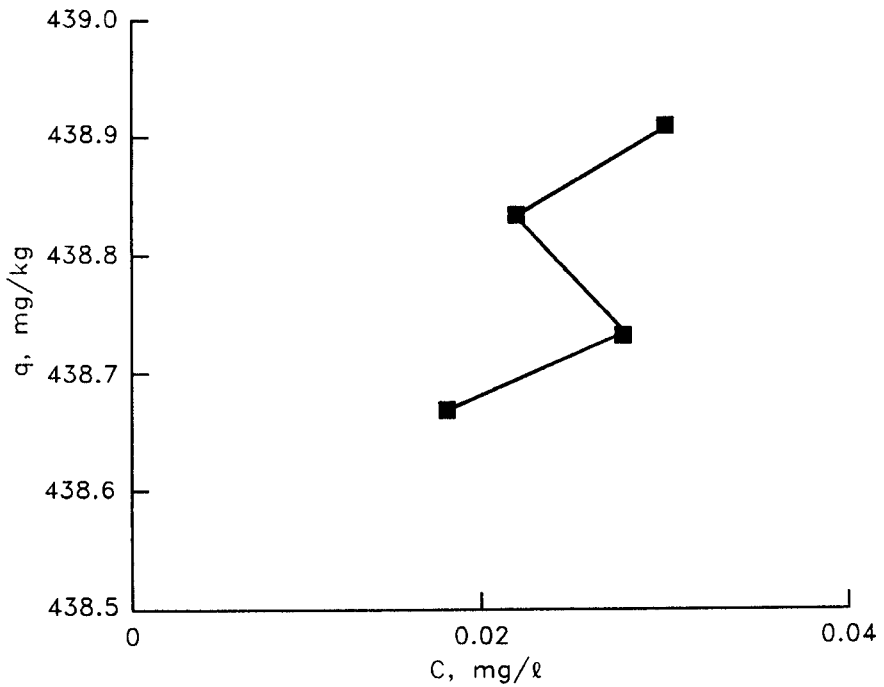

Figure B29. Lead desorption isotherm for midrange concentration composite sediment solidified/stabilized with 0.15 portland cement: 0.15 Firmix:1.0 wet sediment

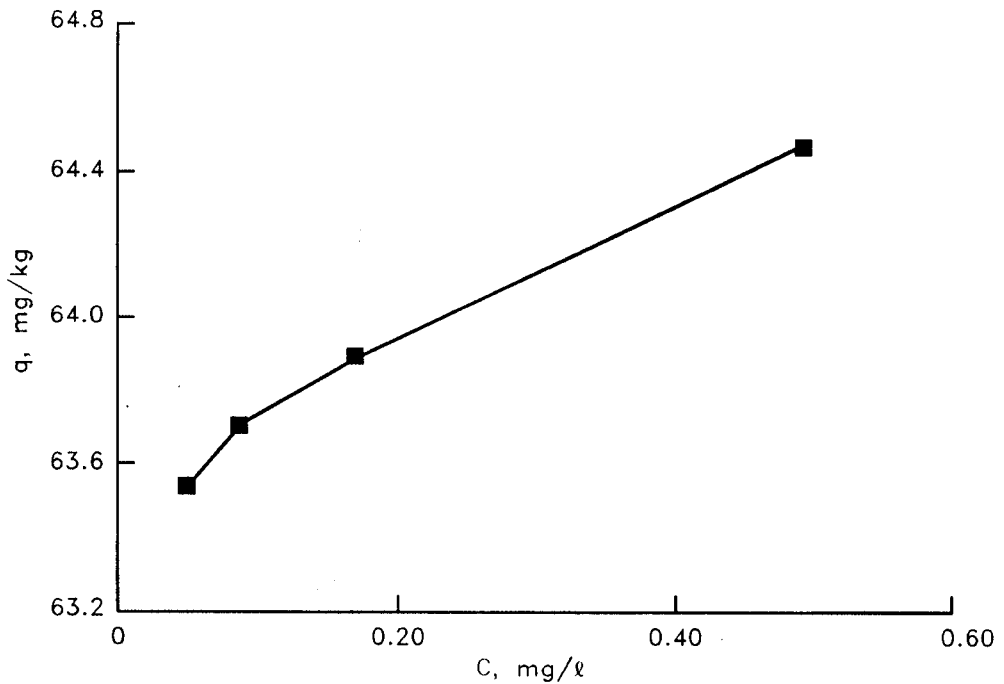

Figure B30. Nickel desorption isotherm for midrange concentration composite sediment solidified/stabilized with 0.15 portland cement: 0.15 Firmix:1.0 wet sediment

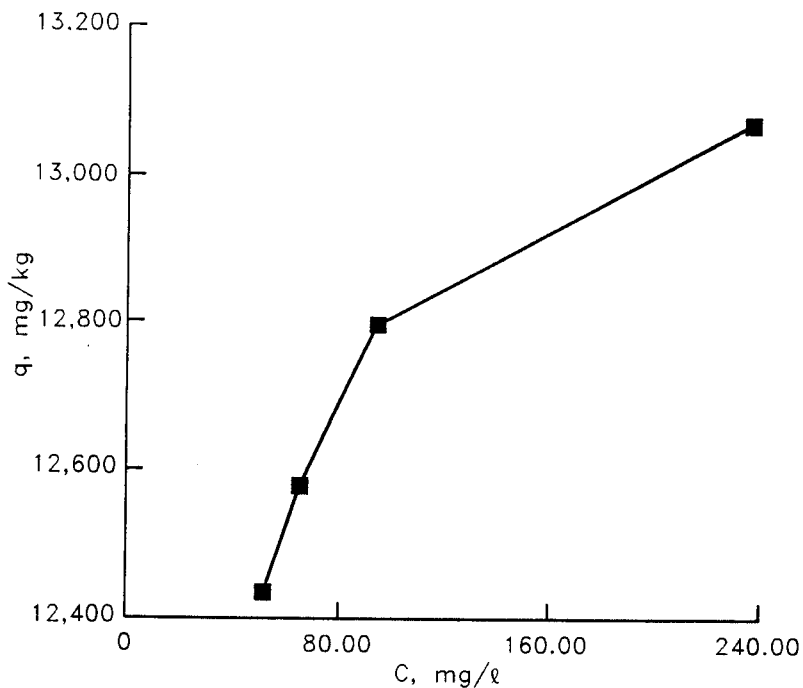

Figure B31. Dissolved desorption isotherm for midrange concentration composite sediment solidified/stabilized with 0.15 portland cement:0.15 Firmix: 1.0 wet sediment

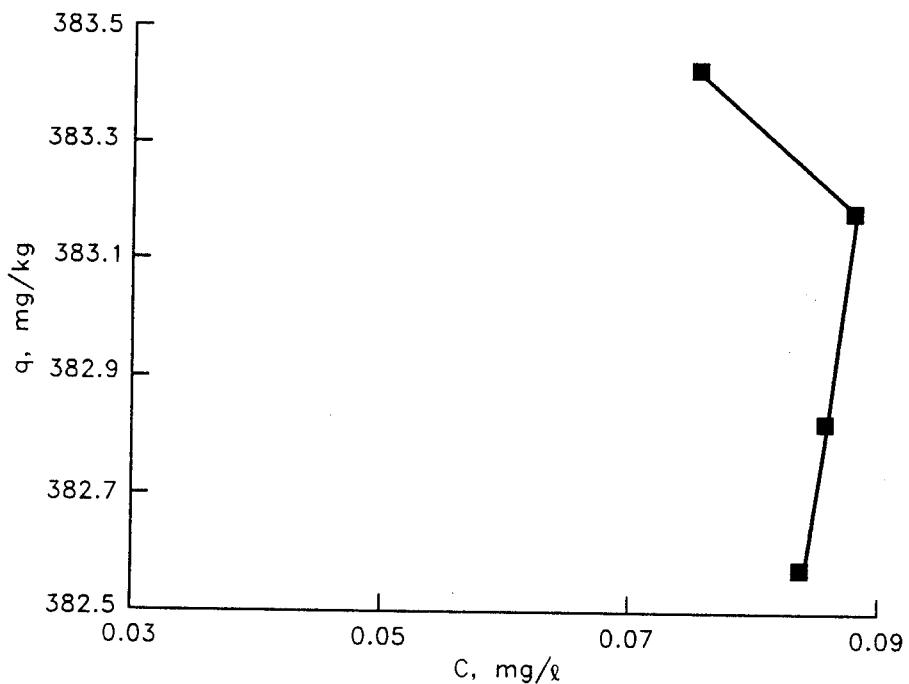

Figure B32. Chromium desorption isotherm for midrange concentration composite sediment solidified/stabilized with 0.1 portland cement:0.2 Firmix: 1.0 wet sediment

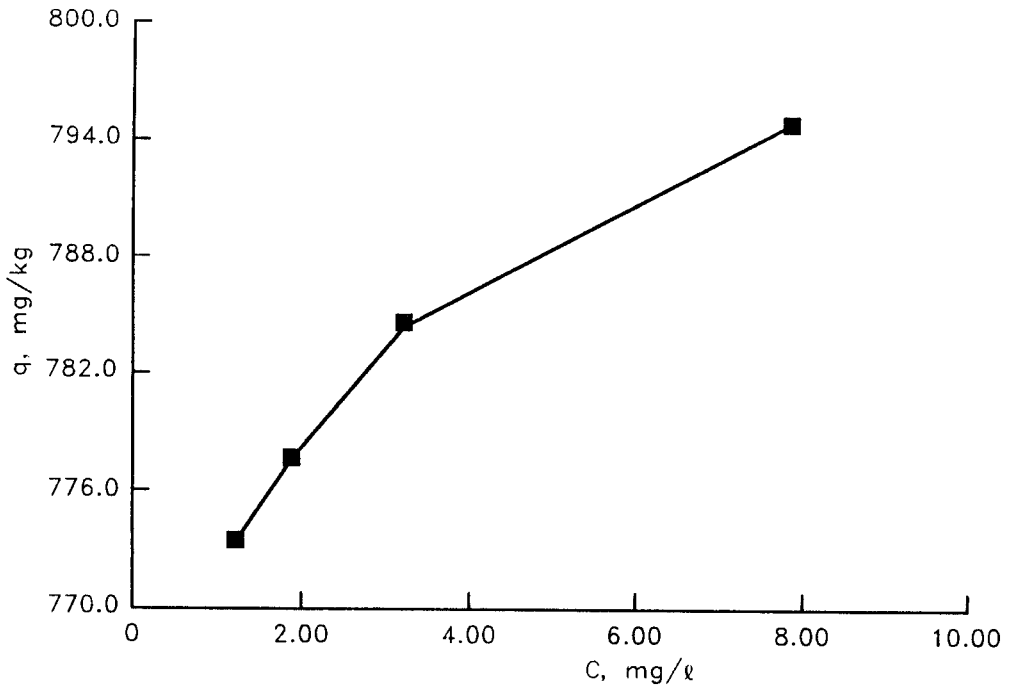

Figure B33. Copper desorption isotherm for midrange concentration composite sediment solidified/stabilized with 0.1 portland cement:0.2 Firmix:1.0 wet sediment

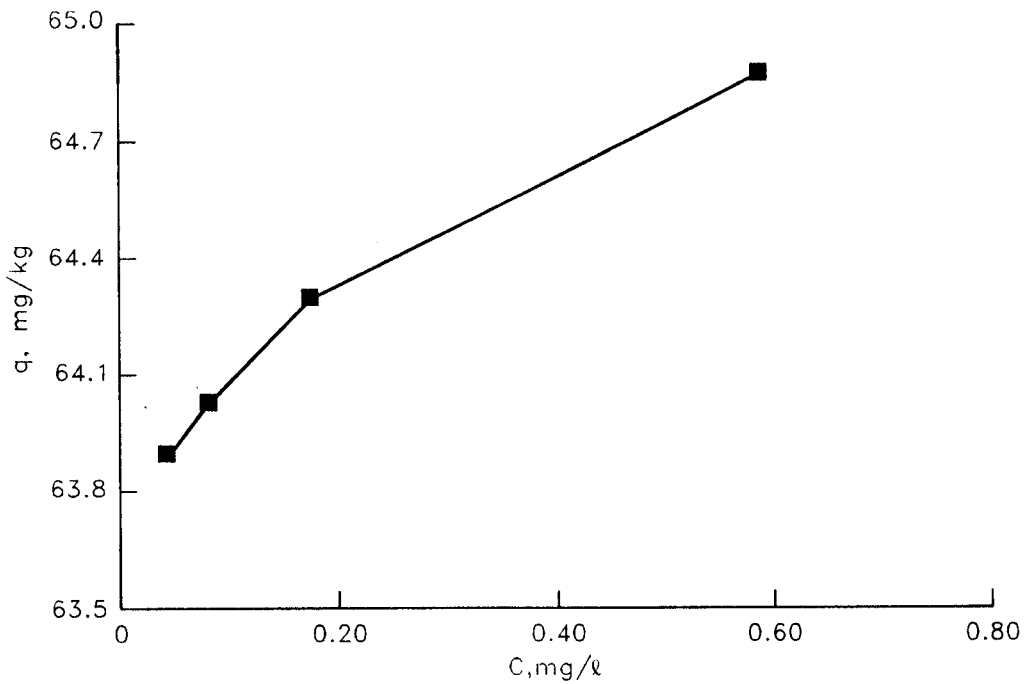

Figure B34. Nickel desorption isotherm for midrange concentration composite sediment solidified/stabilized with 0.1 portland cement:0.2 Firmix:1.0 wet sediment

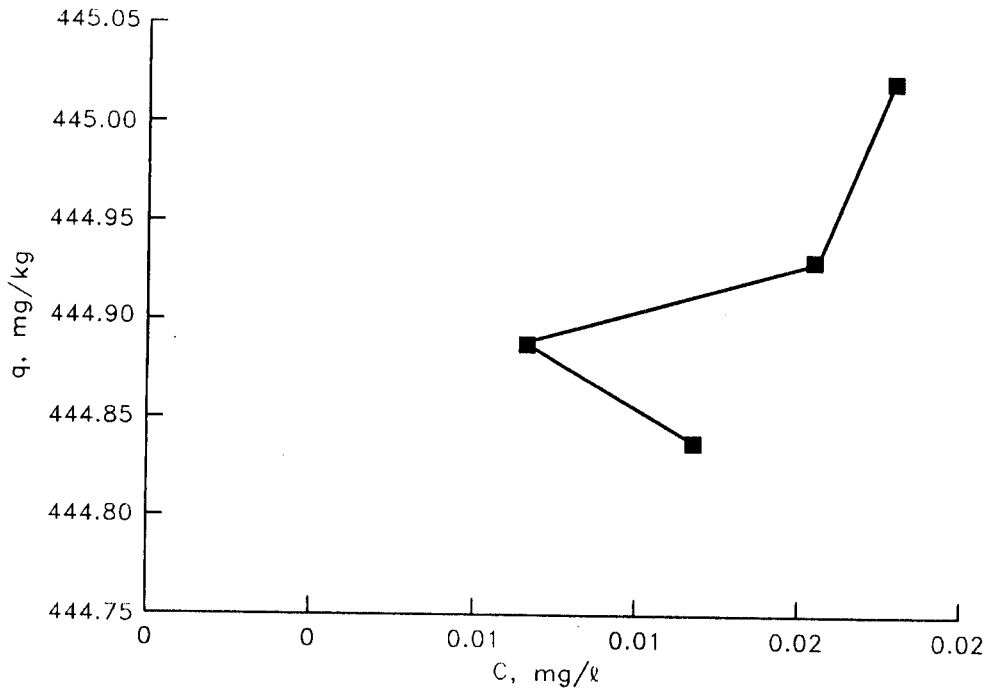

Figure B35. Lead desorption isotherm for midrange concentration composite sediment solidified/stabilized with 0.1 portland cement: 0.2 Firmix:1.0 wet sediment

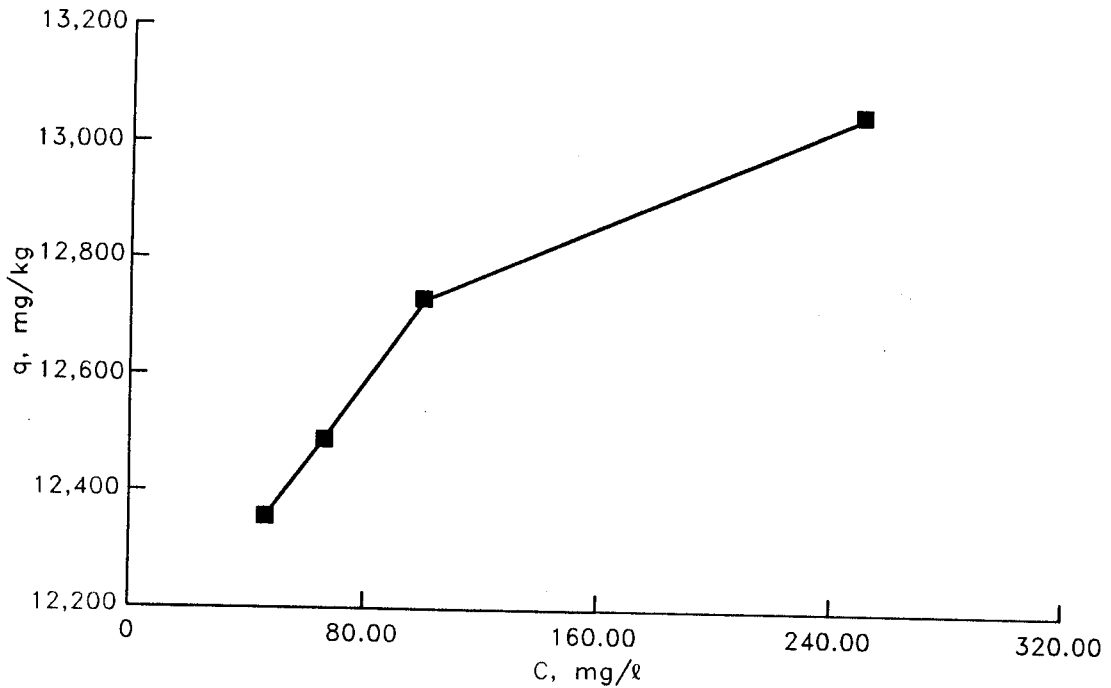

Figure B36. Dissolved organic carbon desorption isotherm for midrange concentration composite sediment solidified/stabilized with 0.1 portland cement: 0.2 Firmix:1.0 wet sediment

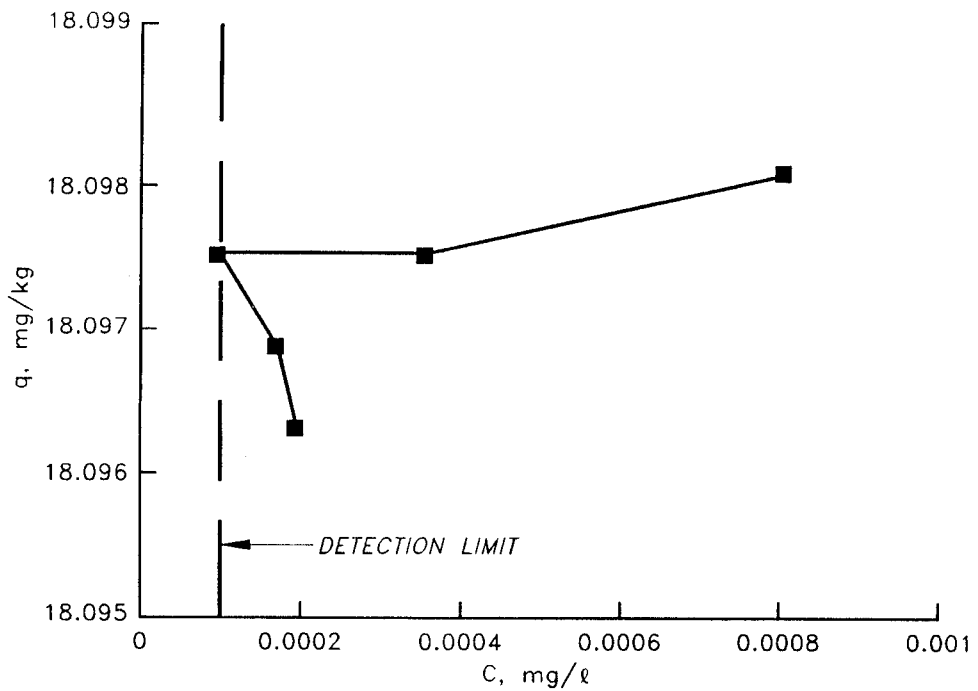

Figure B37. Cadmium desorption isotherm for midrange concentration composite sediment solidified/stabilized with 0.3 STC proprietary additive: 1.0 wet sediment

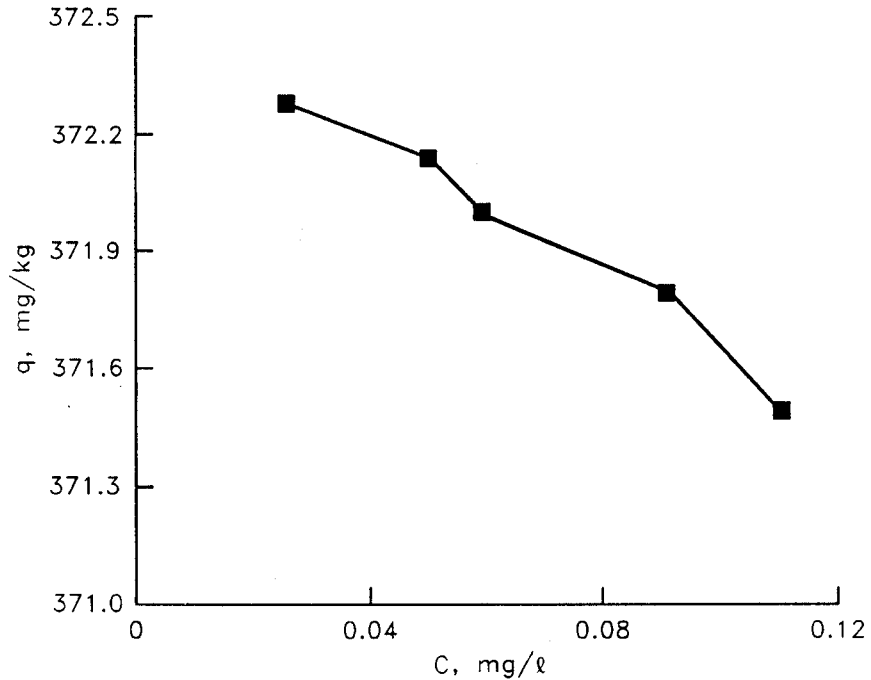

Figure B38. Chromium desorption isotherm for midrange concentration composite sediment solidified/stabilized with 0.3 STC proprietary additive: 1.0 wet sediment

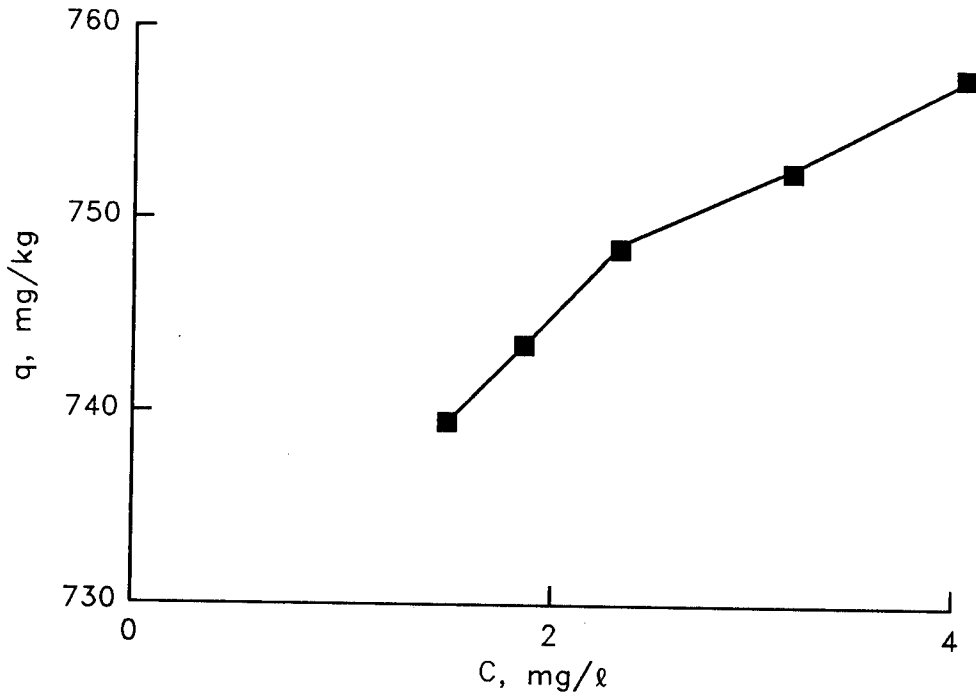

Figure B39. Copper desorption isotherm for midrange concentration composite sediment solidified/stabilized with 0.3 STC proprietary additive: 1.0 wet sediment

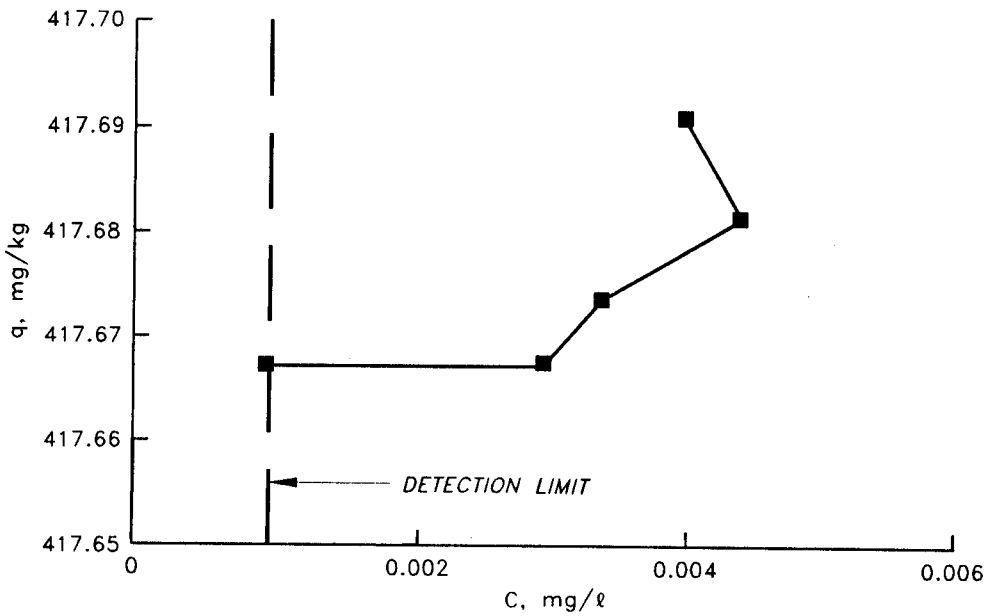

Figure B40. Lead desorption isotherm for midrange concentration composite sediment solidified/stabilized with 0.3 STC proprietary additive: 1.0 wet sediment

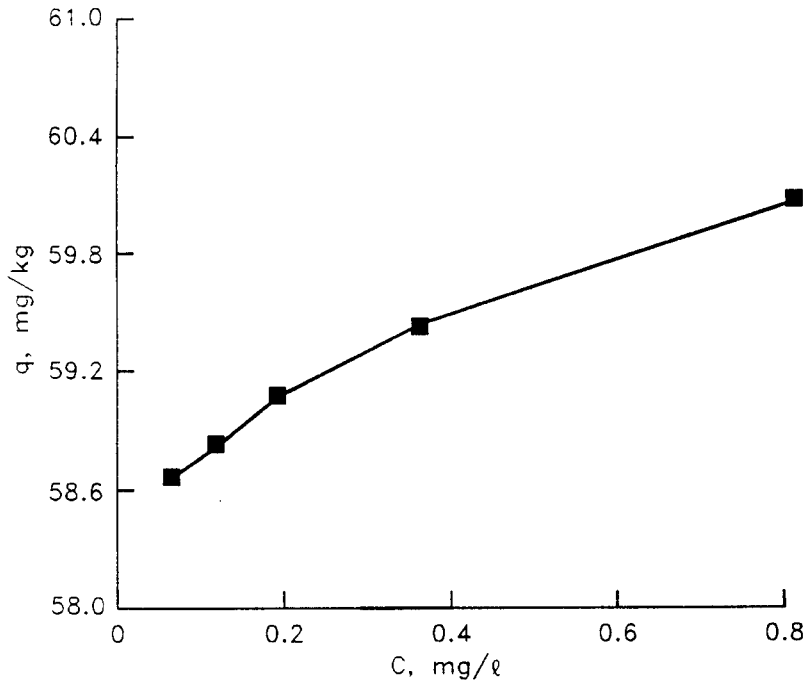

Figure B41. Nickel desorption isotherm for mid-range concentration composite sediment solidified/stabilized with 0.3 STC proprietary additive: 1.0 wet sediment

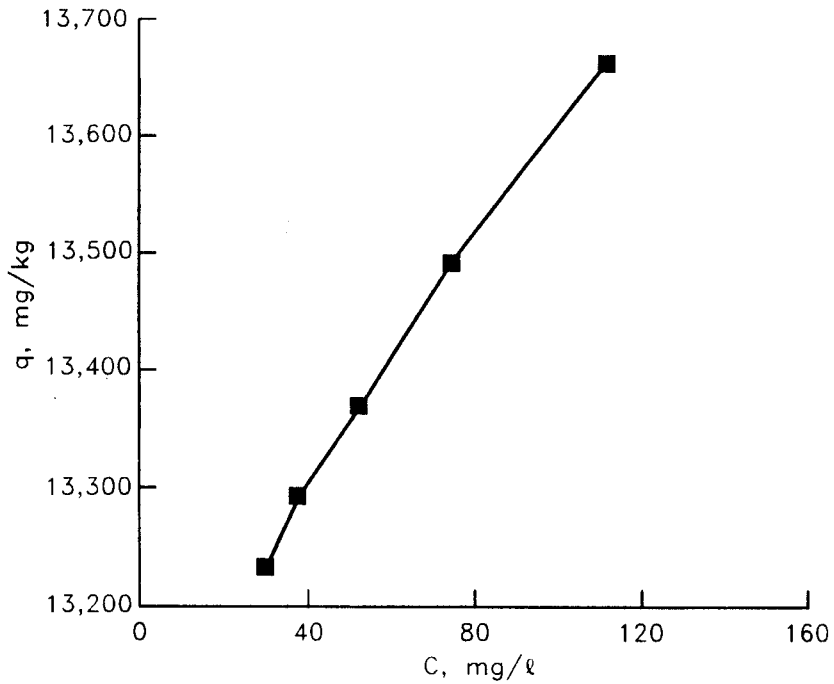

Figure B42. Dissolved organic carbon desorption isotherm for midrange concentration composite sediment solidified/stabilized with 0.3 STC proprietary additive: 1.0 wet sediment

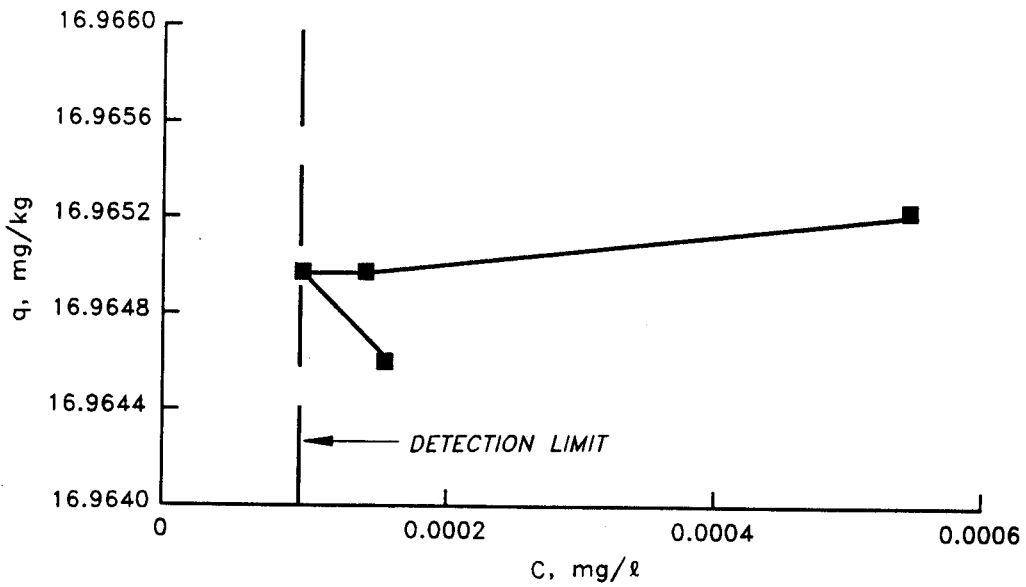

Figure B43. Cadmium desorption isotherm for hot-spot sediment solidified/stabilized with 0.3 portland cement:1.0 wet sediment

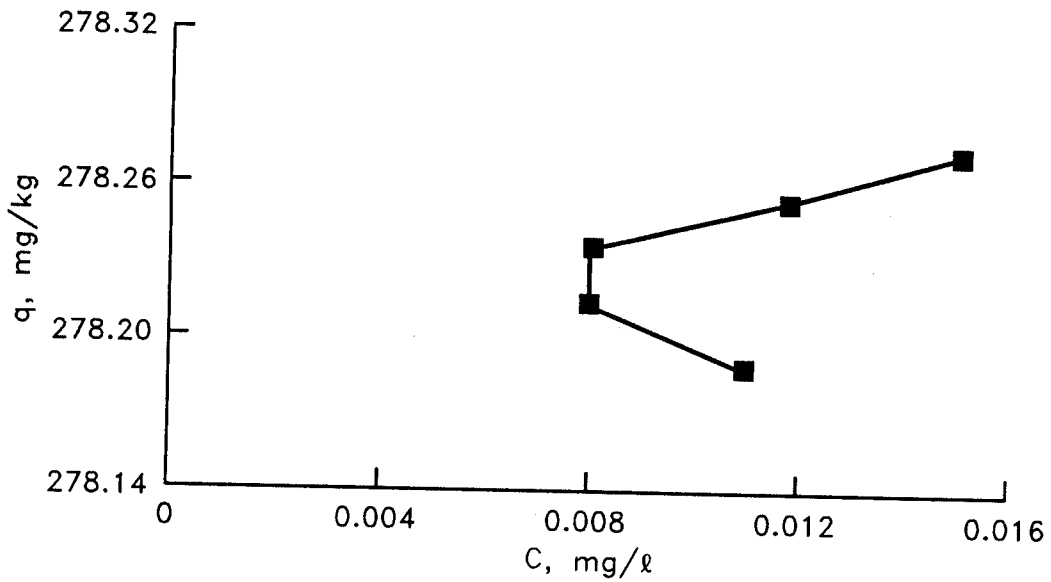

Figure B44. Chromium desorption isotherm for hot-spot sediment solidified/stabilized with 0.3 portland cement:1.0 wet sediment

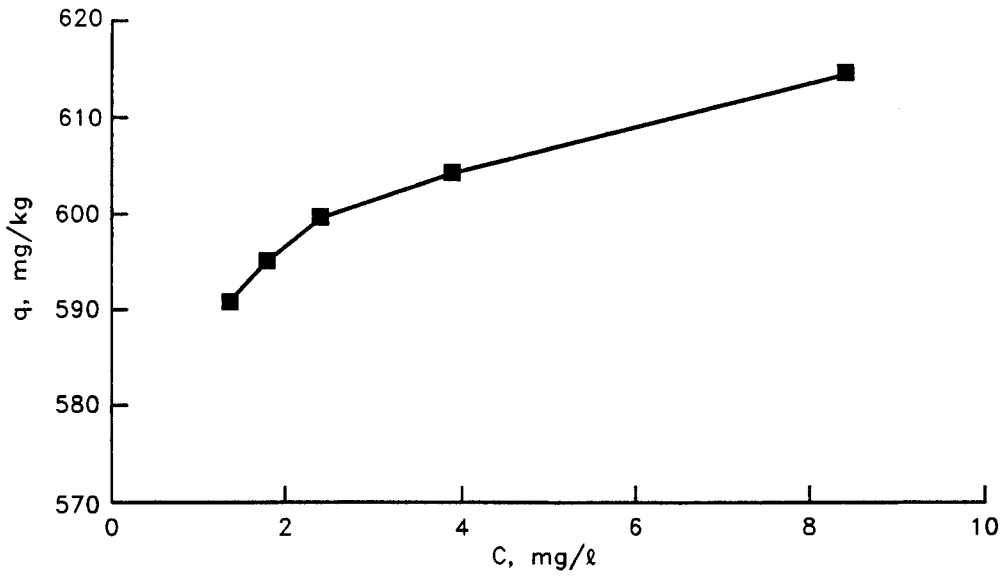

Figure B45. Copper desorption isotherm for hot-spot sediment solidified/stabilized with 0.3 portland cement:1.0 wet sediment

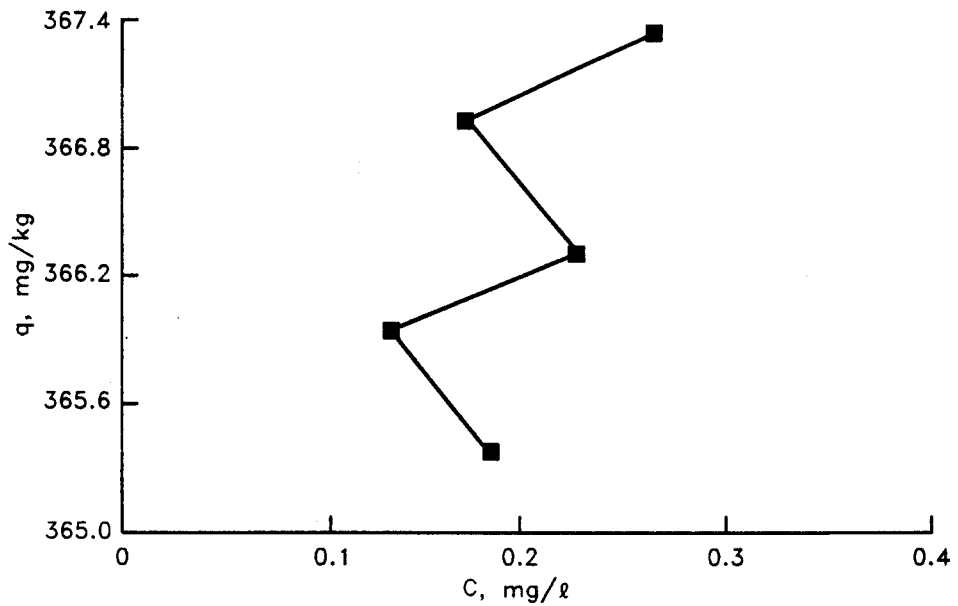

Figure B46. Lead desorption isotherm for hot-spot sediment solidified/stabilized with 0.3 portland cement:1.0 wet sediment

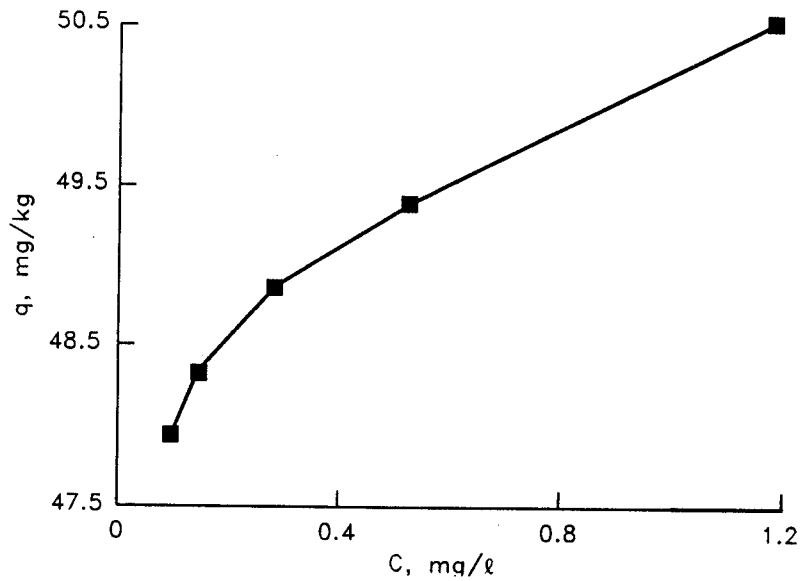

Figure B47. Nickel desorption isotherm for hot-spot sediment solidified/stabilized with 0.3 portland cement:1.0 wet sediment

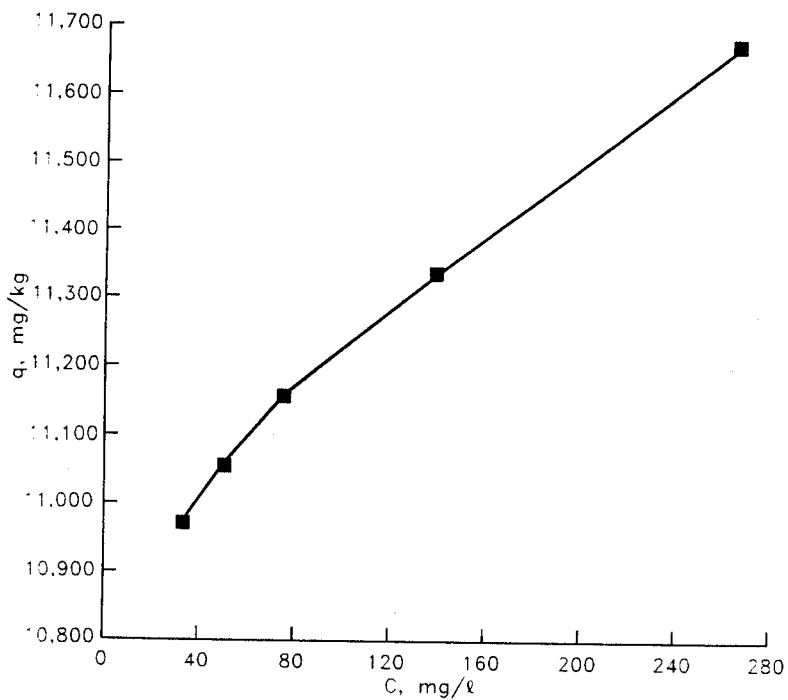

Figure B48. Dissolved organic carbon desorption isotherm for hot-spot sediment solidified/stabilized with 0.3 portland cement:1.0 wet sediment

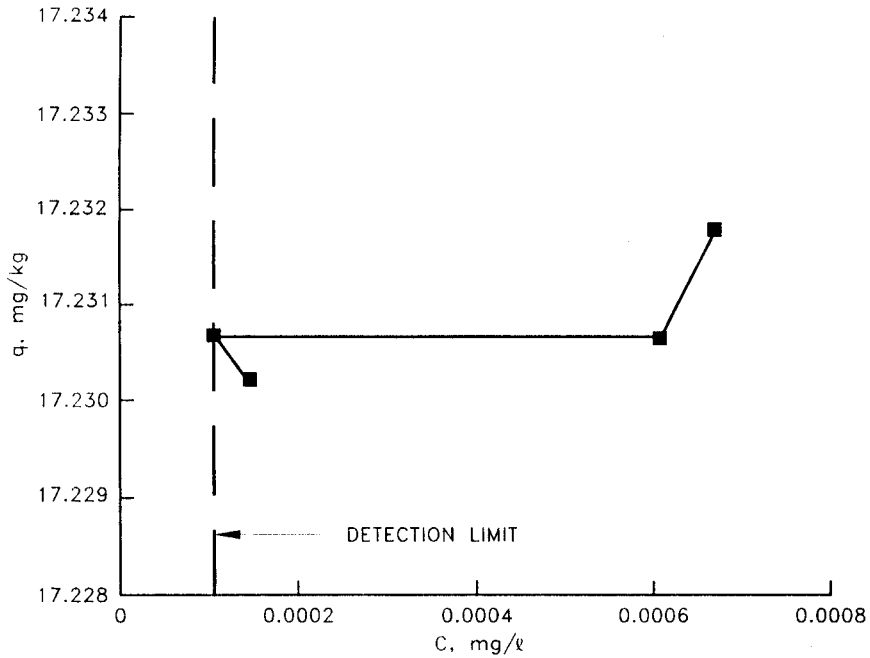

Figure B49. Cadmium desorption isotherm for hot-spot sediment solidified/stabilized with 0.3 STC proprietary additive:1.0 wet sediment

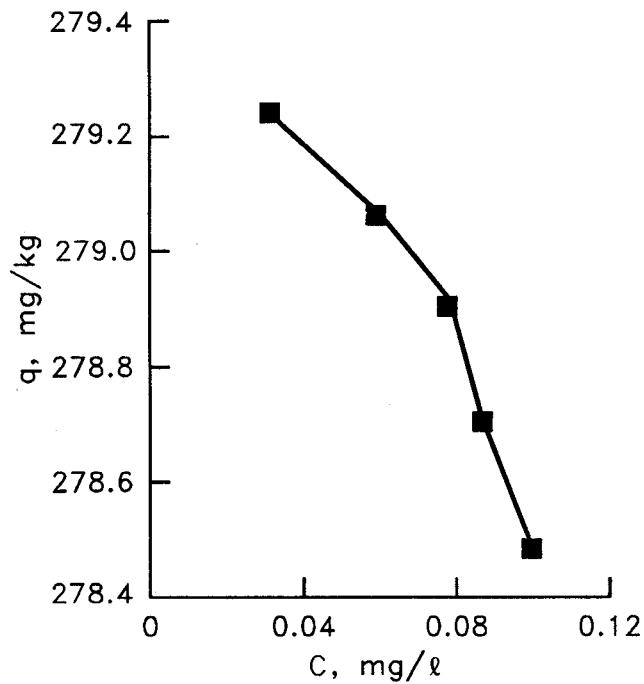

Figure B50. Chromium desorption isotherm for hot-spot sediment solidified/stabilized with 0.3 STC proprietary additive:1.0 wet sediment

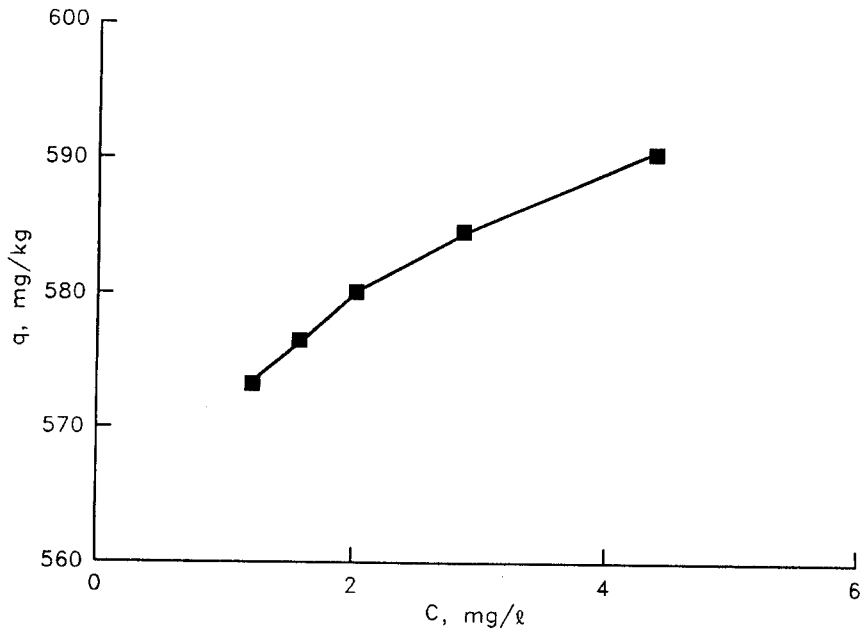

Figure B51. Copper desorption isotherm for hot-spot sediment solidified/stabilized with 0.3 STC proprietary additive:1.0 wet sediment

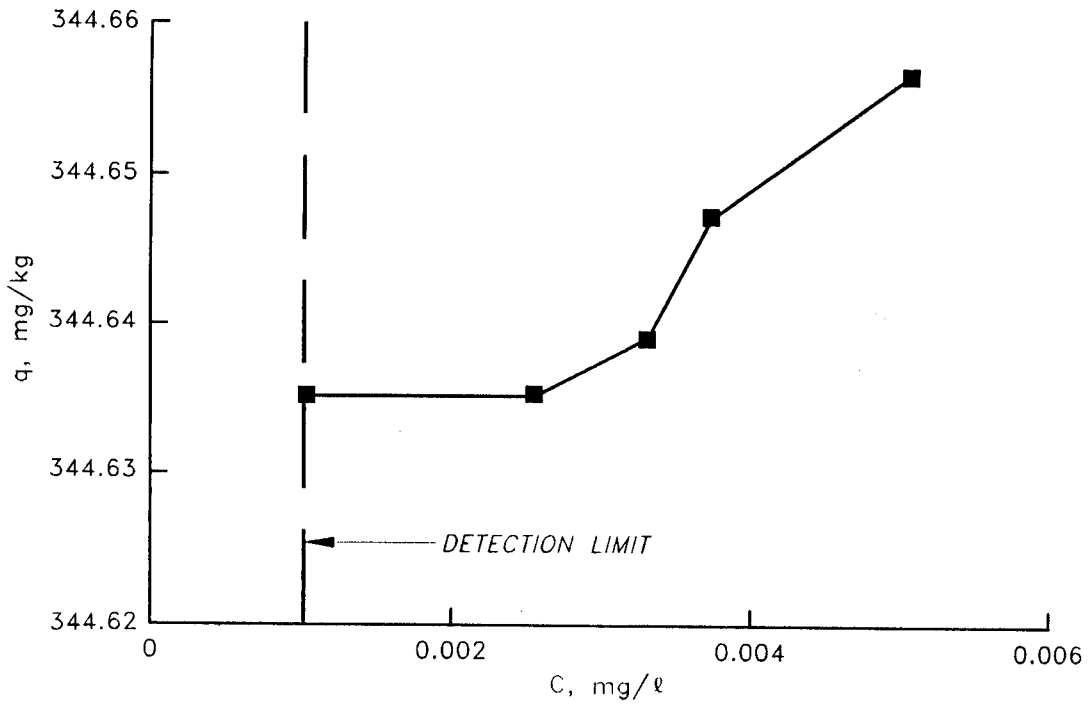

Figure B52. Lead desorption isotherm for hot-spot sediment solidified/stabilized with 0.3 STC proprietary additive:1.0 wet sediment

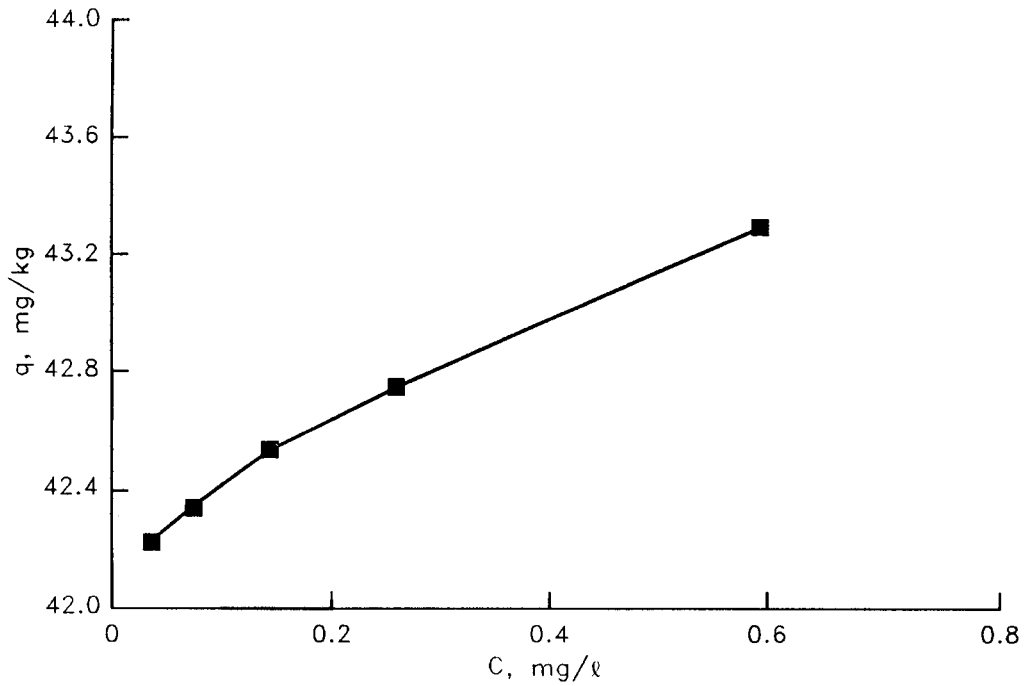

Figure B53. Nickel desorption isotherm for hot-spot sediment solidified/stabilized with 0.3 STC proprietary additive:1.0 wet sediment

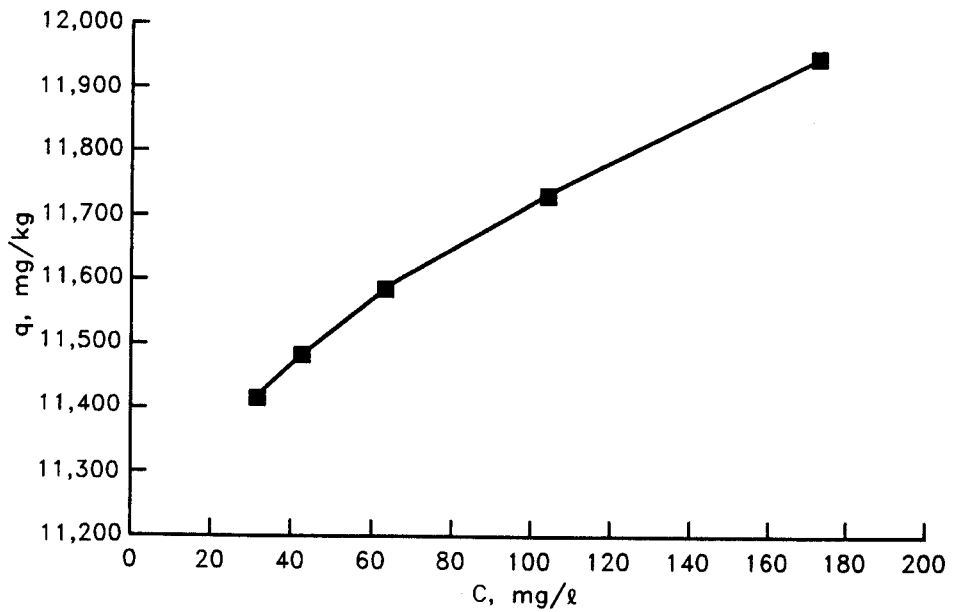

Figure B54. Dissolved desorption isotherm for hot-spot sediment solidified/stabilized with 0.3 STC proprietary additive:1.0 wet sediment

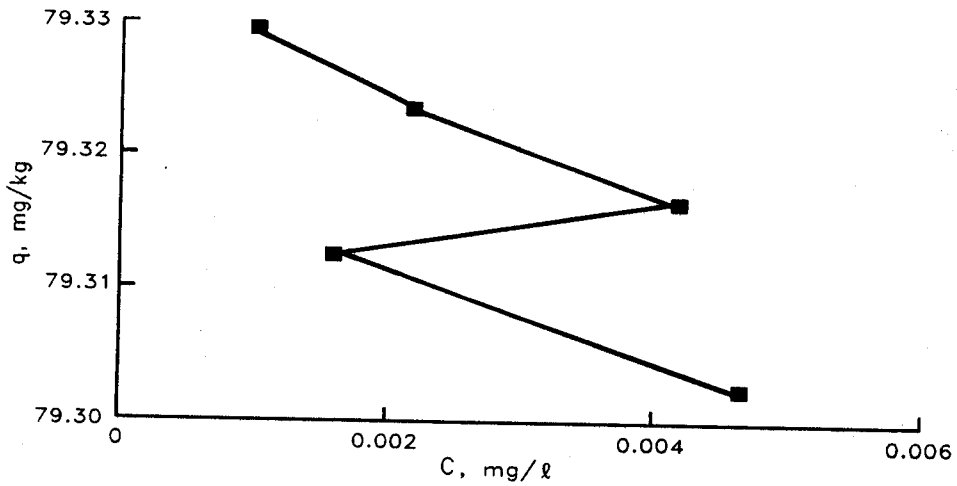

Figure B59. PCB congener C8 desorption isotherm for midrange concentration composite sediment solidified/stabilized with 0.3 STC proprietary additive: 1.0 wet sediment

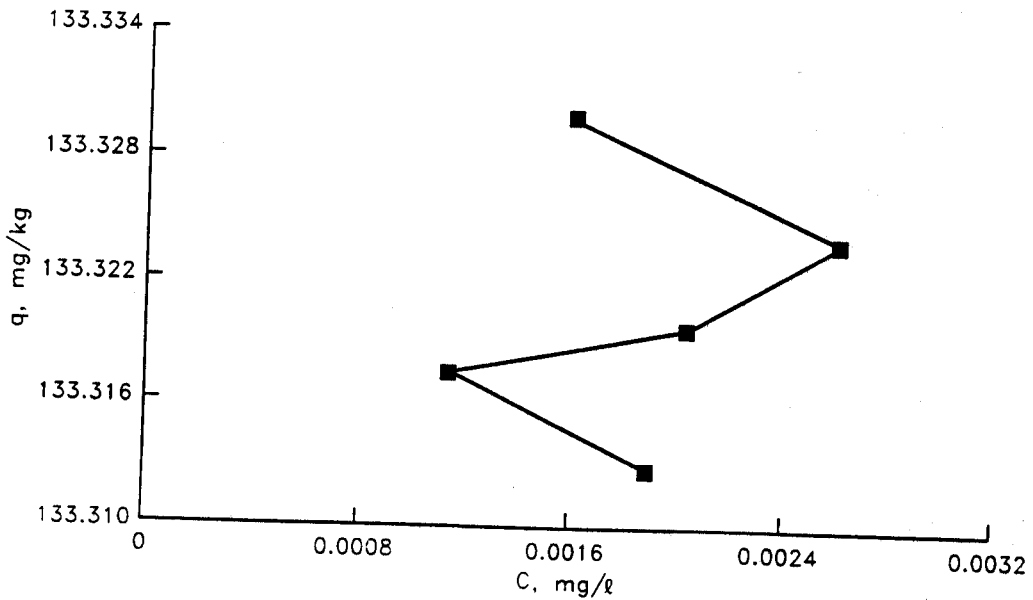

Figure B60. PCB congener C28 desorption isotherm for midrange concentration composite sediment solidified/stabilized with 0.3 STC proprietary additive: 1.0 wet sediment

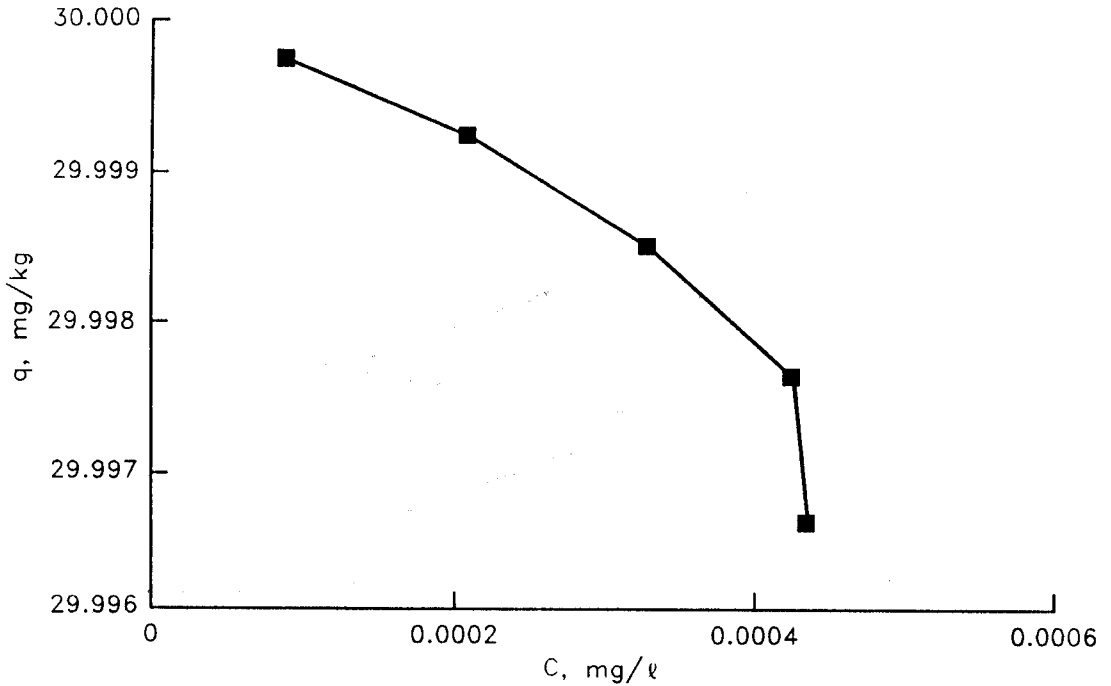

Figure B61. PCB congener C44 desorption isotherm for midrange concentration composite sediment solidified/stabilized with 0.3 STC proprietary additive: 1.0 wet sediment

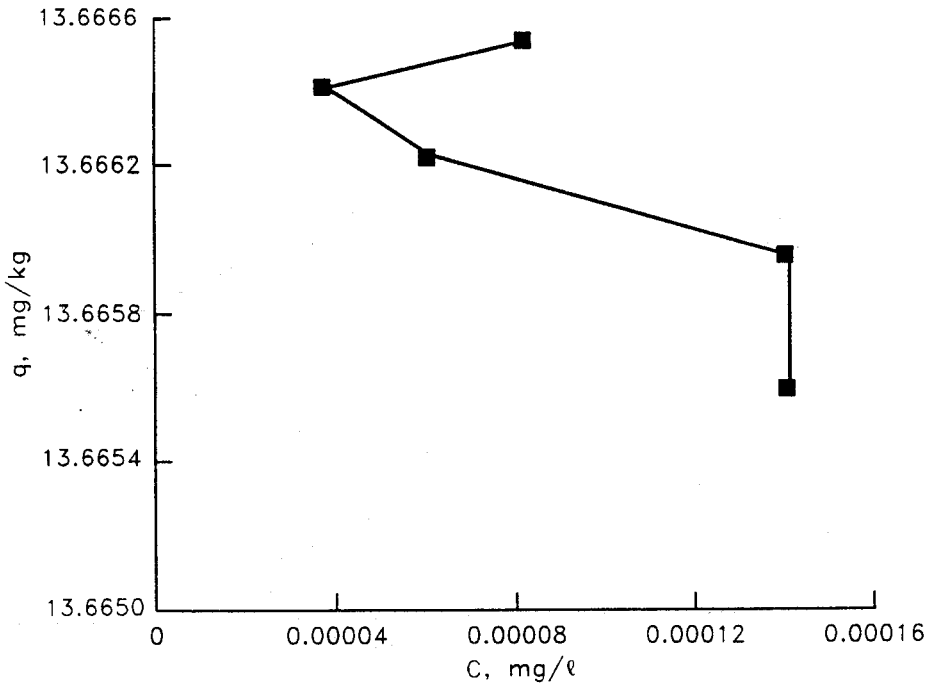

Figure B62. PCB congener C49 desorption isotherm for midrange concentration composite sediment solidified/stabilized with 0.3 STC proprietary additive: 1.0 wet sediment

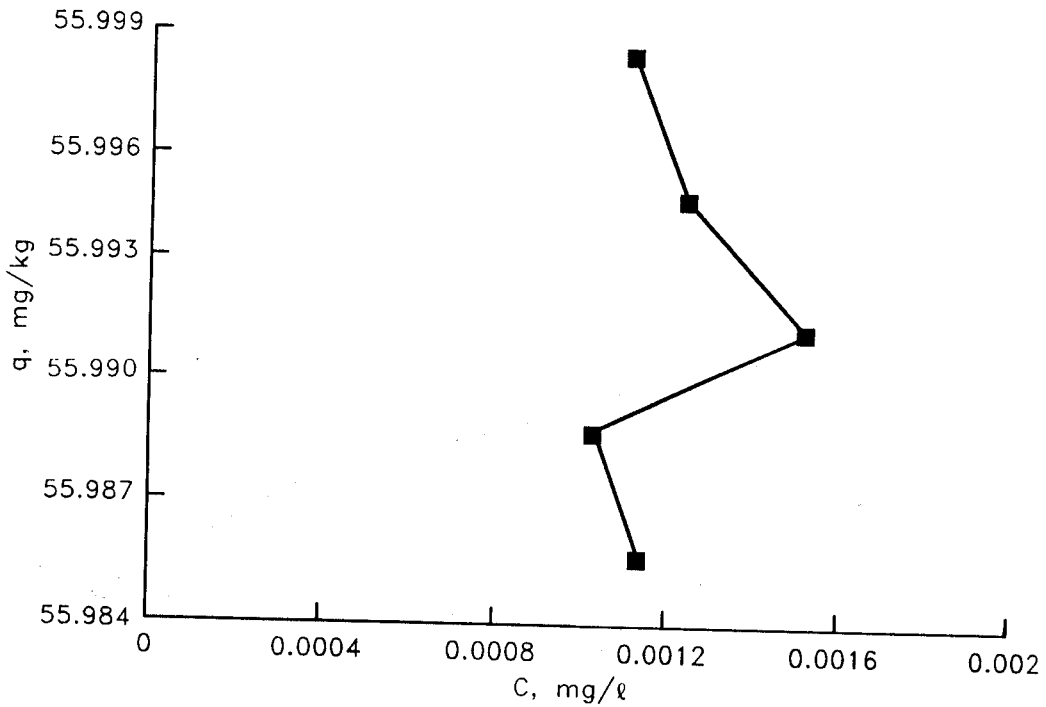

Figure B63. PCB congener C50 desorption isotherm for midrange concentration composite sediment solidified/stabilized with 0.3 STC proprietary additive: 1.0 wet sediment

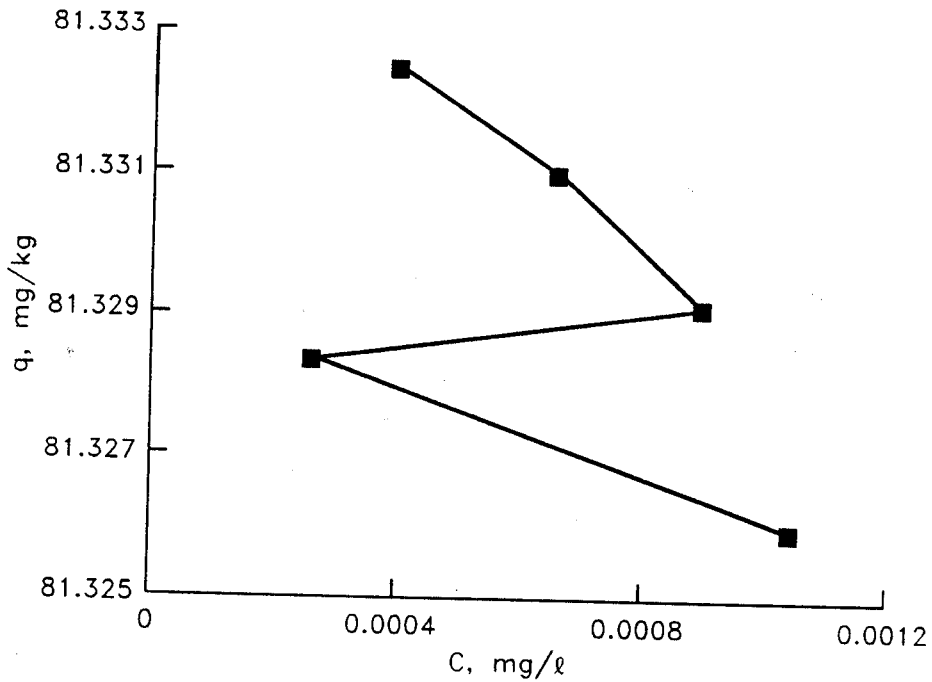

Figure B64. PCB congener C52 desorption isotherm for midrange concentration composite sediment solidified/stabilized with 0.3 STC proprietary additive: 1.0 wet sediment

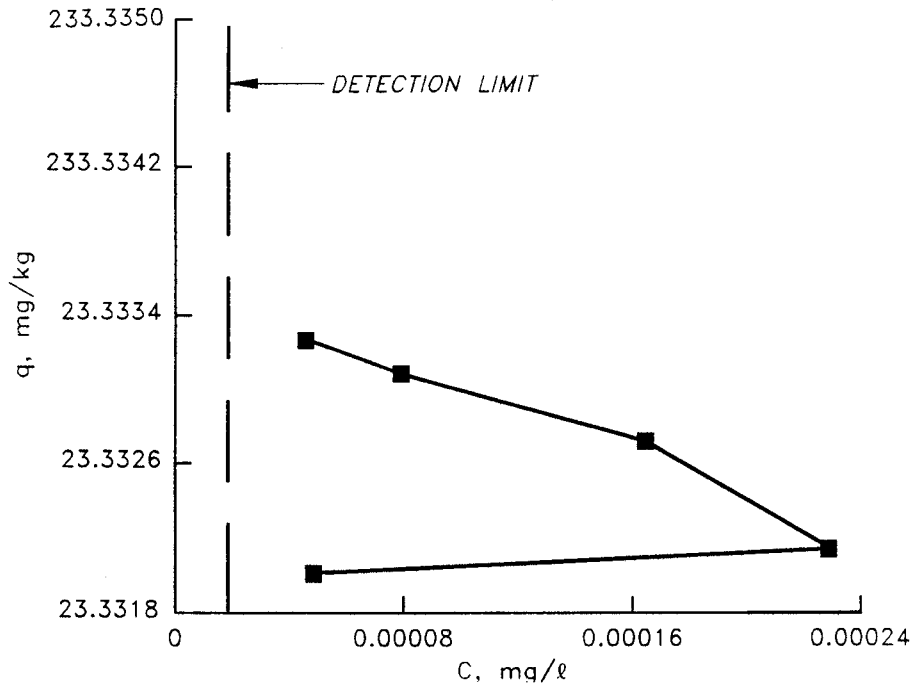

Figure B65. PCB congener C70 desorption isotherm for midrange concentration composite sediment solidified/stabilized with 0.3 STC proprietary additive: 1.0 wet sediment

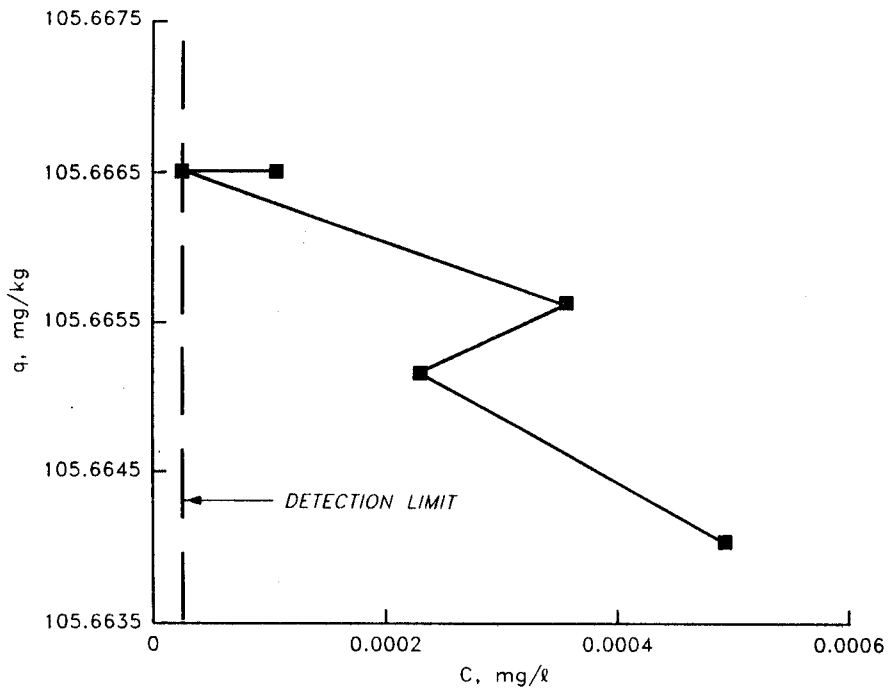

Figure B66. PCB congener C77 desorption isotherm for midrange concentration composite sediment solidified/stabilized with 0.3 STC proprietary additive: 1.0 wet sediment

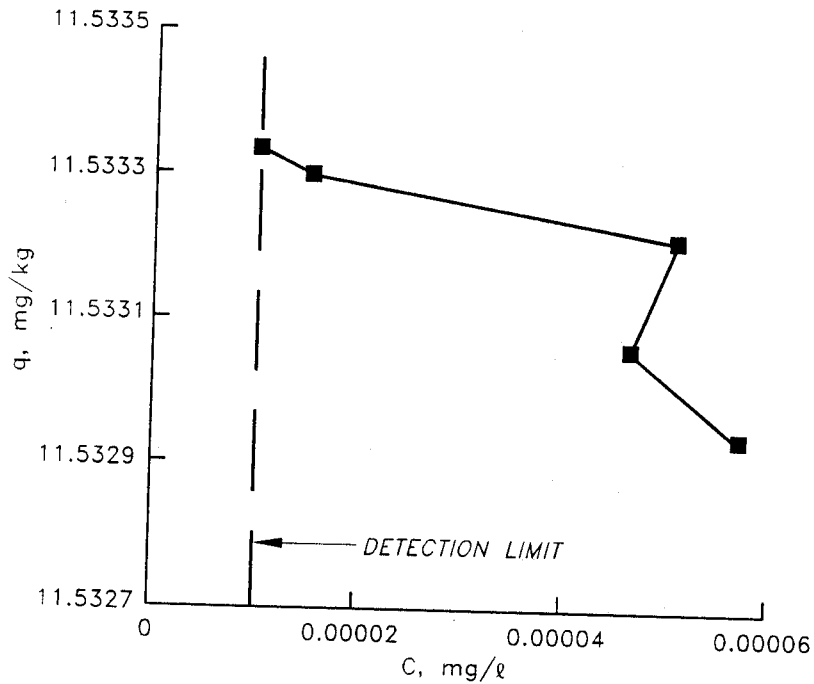

Figure B67. PCB congener C87 desorption isotherm for midrange concentration composite sediment solidified/stabilized with 0.3 STC proprietary additive: 1.0 wet sediment

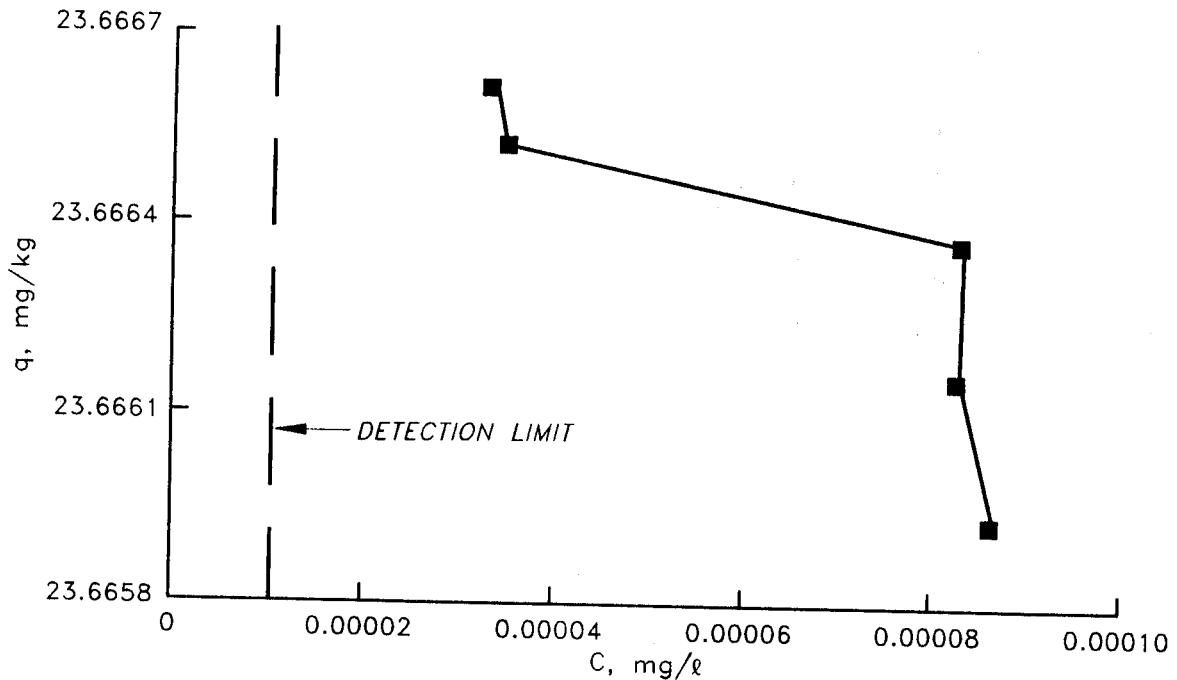

Figure B68. PCB congener C97 desorption isotherm for midrange concentration composite sediment solidified/stabilized with 0.3 STC proprietary additive: 1.0 wet sediment

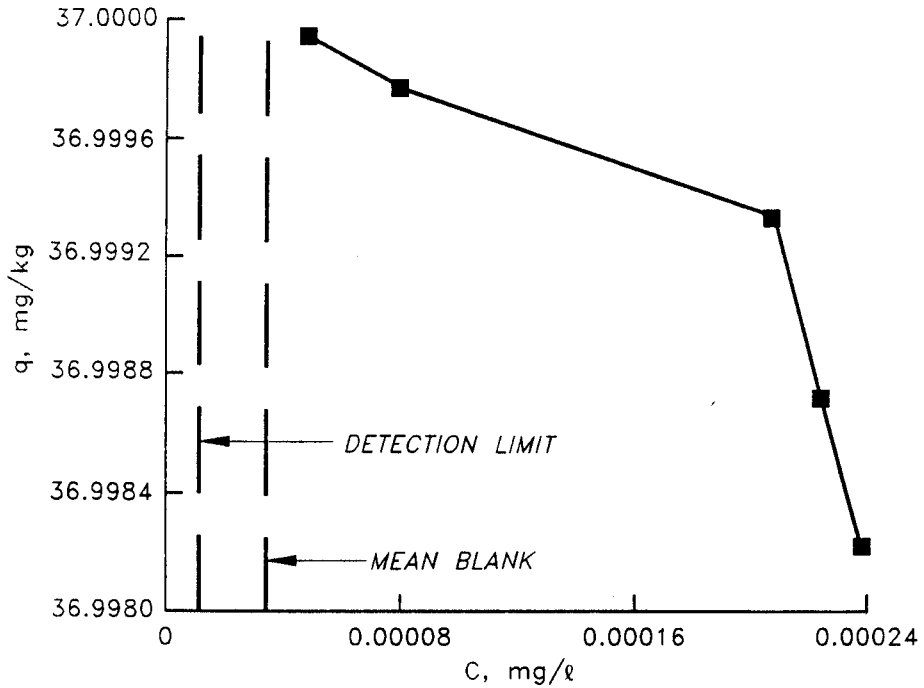

Figure B69. PCB congener C101 desorption isotherm for midrange concentration composite sediment solidified/stabilized with 0.3 STC proprietary additive: 1.0 wet sediment

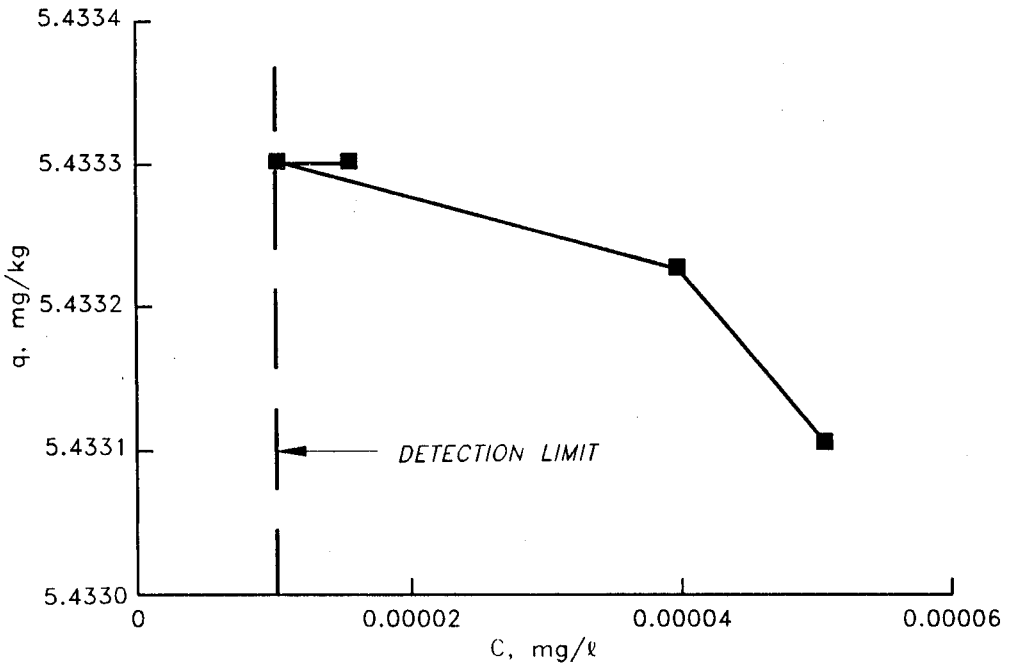

Figure B70. PCB congener C105 desorption isotherm for midrange concentration composite sediment solidified/stabilized with 0.3 STC proprietary additive: 1.0 wet sediment

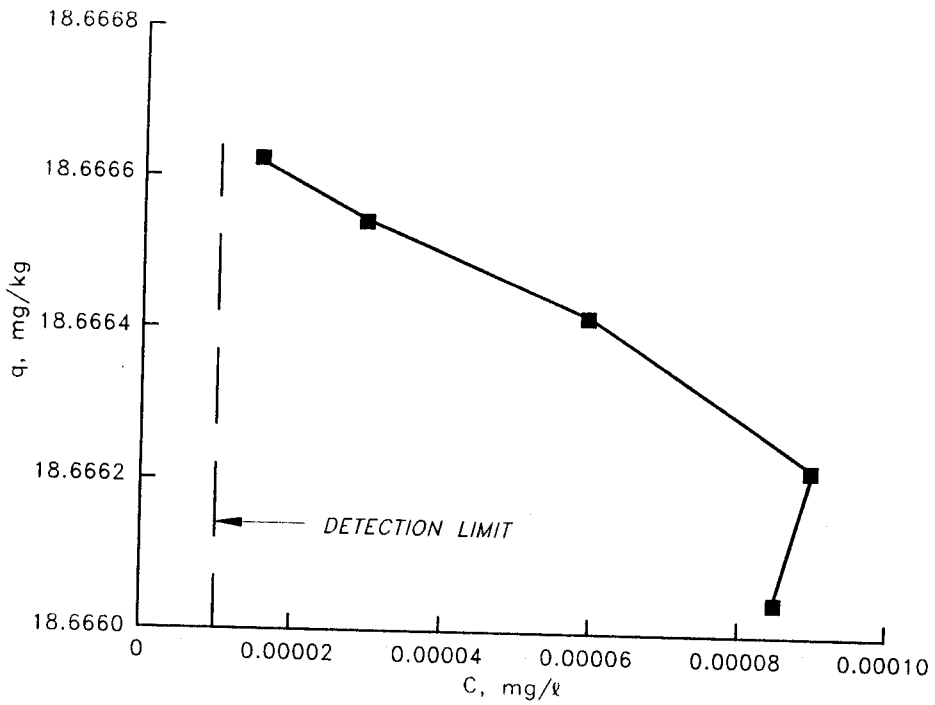

Figure B71. PCB congener C118 desorption isotherm for midrange concentration composite sediment solidified/stabilized with 0.3 STC proprietary additive: 1.0 wet sediment

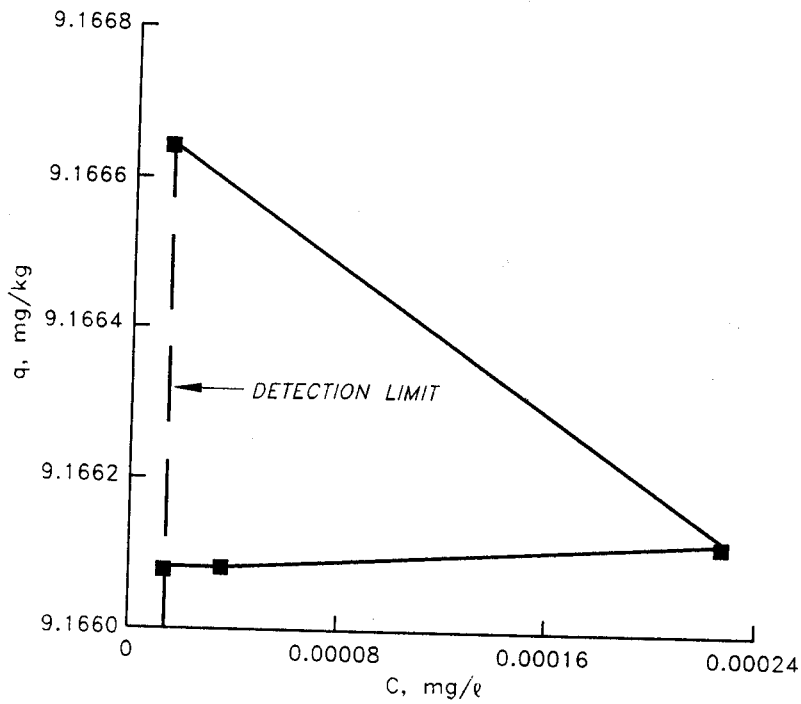

Figure B72. PCB congener C136 desorption isotherm for midrange concentration composite sediment solidified/stabilized with 0.3 STC proprietary additive: 1.0 wet sediment

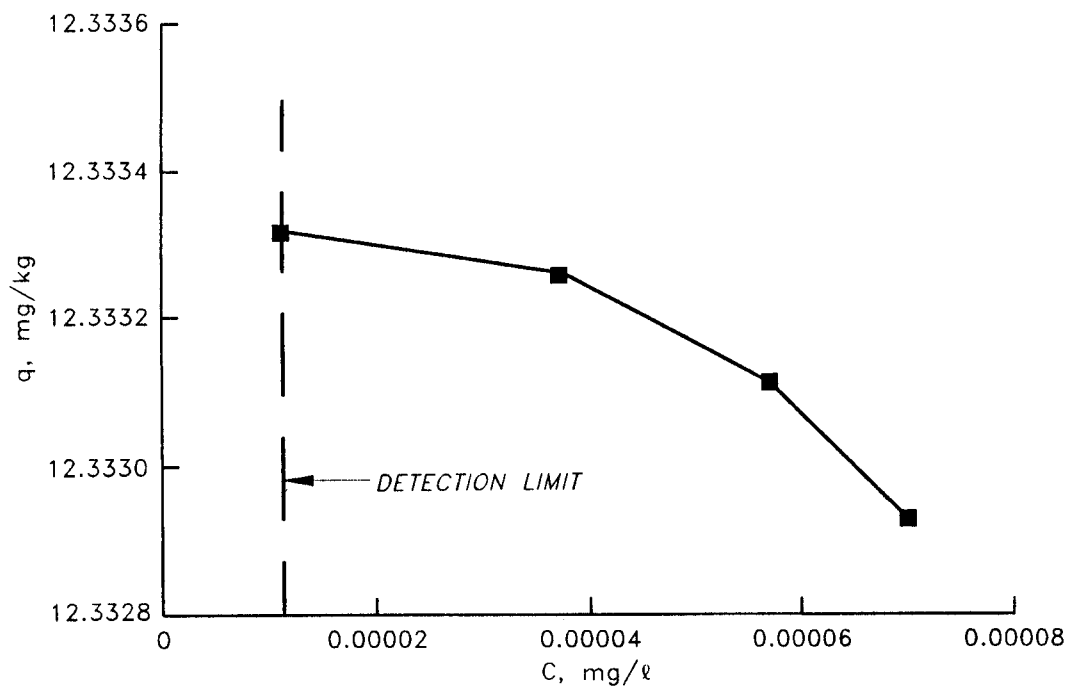

Figure B73. PCB congener C138 desorption isotherm for midrange concentration composite sediment solidified/stabilized with 0.3 STC proprietary additive: 1.0 wet sediment

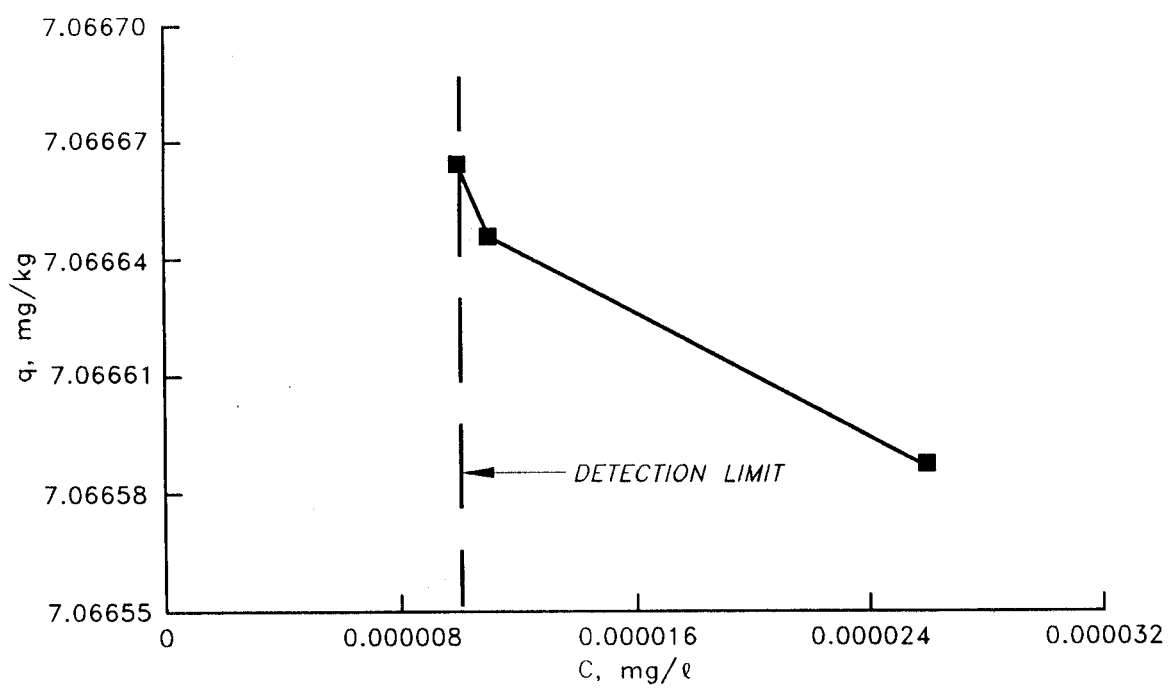

Figure B74. PCB congener C143 desorption isotherm for midrange concentration composite sediment solidified/stabilized with 0.3 STC proprietary additive: 1.0 wet sediment

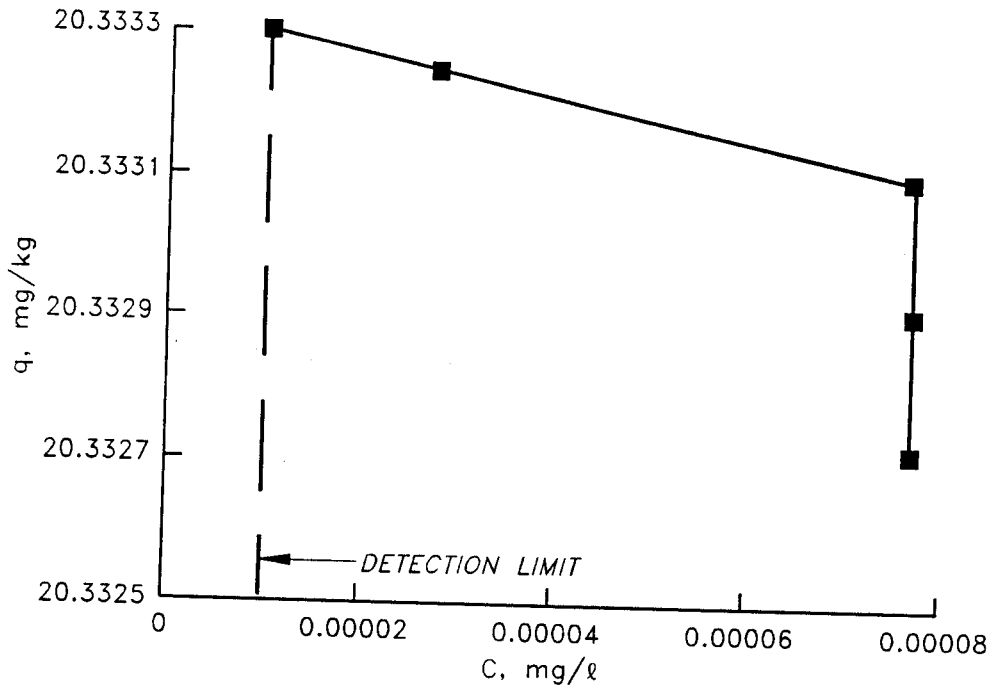

Figure B75. PCB congener C153 desorption isotherm for midrange concentration composite sediment solidified/stabilized with 0.3 STC proprietary additive: 1.0 wet sediment

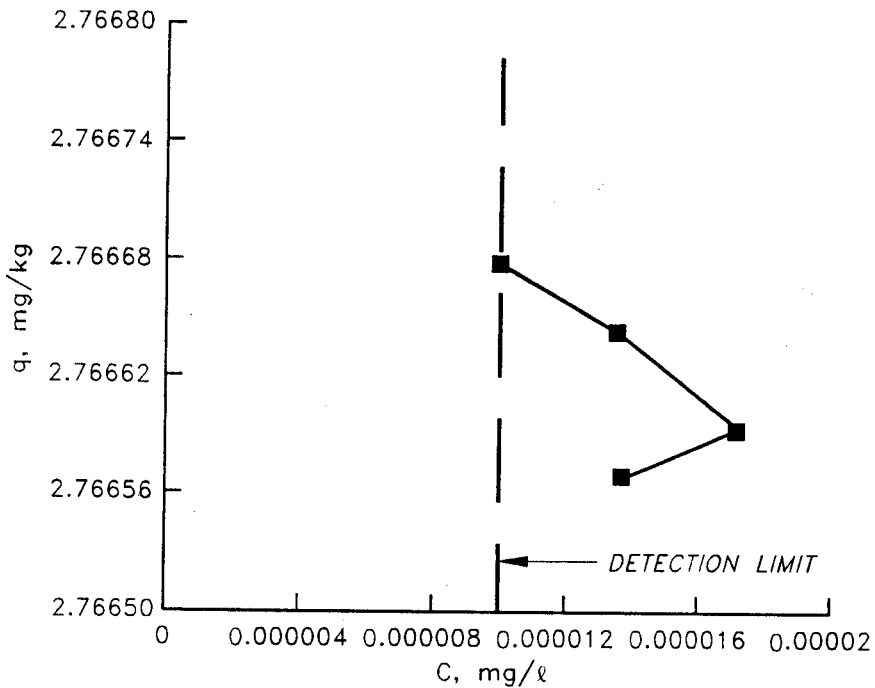

Figure B76. PCB congener C180 desorption isotherm for midrange concentration composite sediment solidified/stabilized with 0.3 STC proprietary additive: 1.0 wet sediment

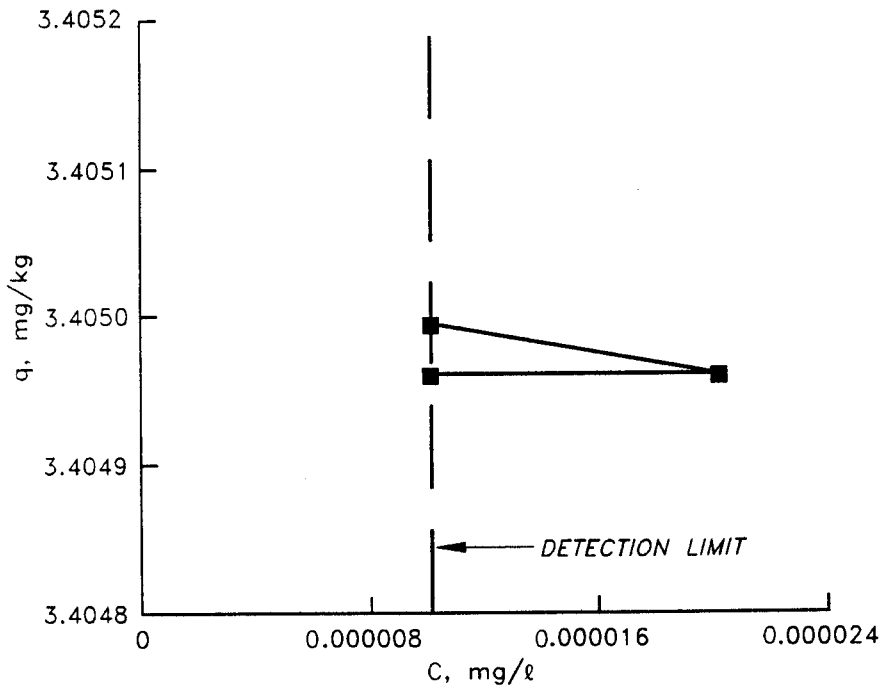

Figure B77. PCB congener C185 desorption isotherm for midrange concentration composite sediment solidified/stabilized with 0.3 STC proprietary additive: 1.0 wet sediment

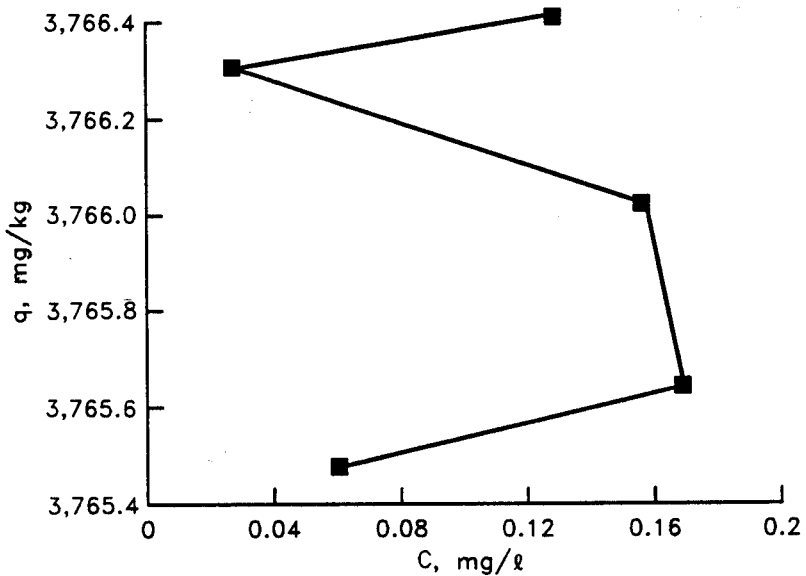

Figure B78. Total-PCB desorption isotherm for hot-spot sediment solidified/stabilized with 0.3 STC proprietary additive: 1.0 wet sediment

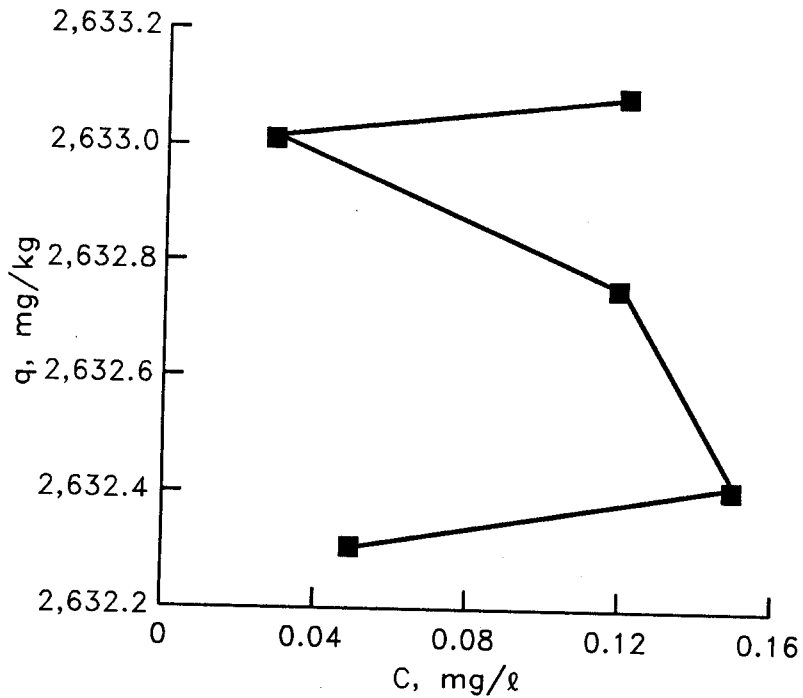

Figure B79. Aroclor 1242 desorption isotherm for hot-spot sediment solidified/stabilized with 0.3 STC proprietary additive:1.0 wet sediment

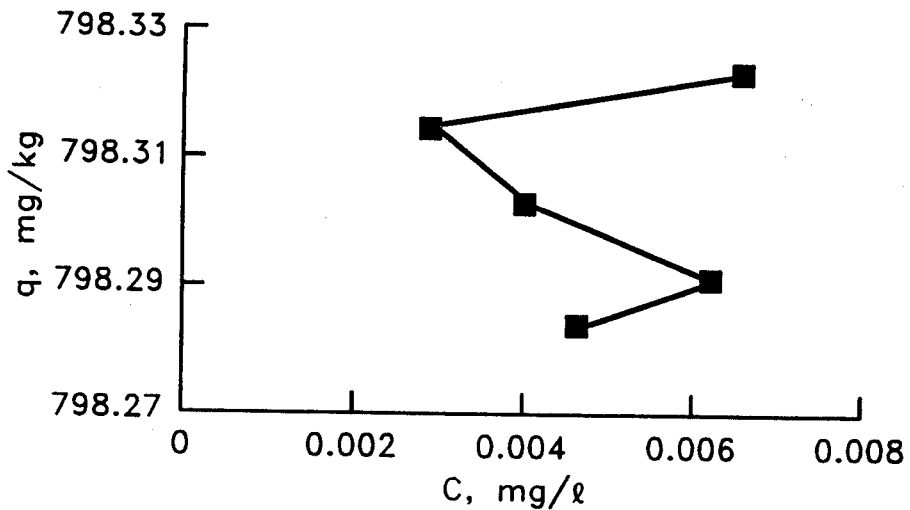

Figure B80. Aroclor 1254 desorption isotherm for hot-spot sediment solidified/stabilized with 0.3 STC proprietary additive:1.0 wet sediment

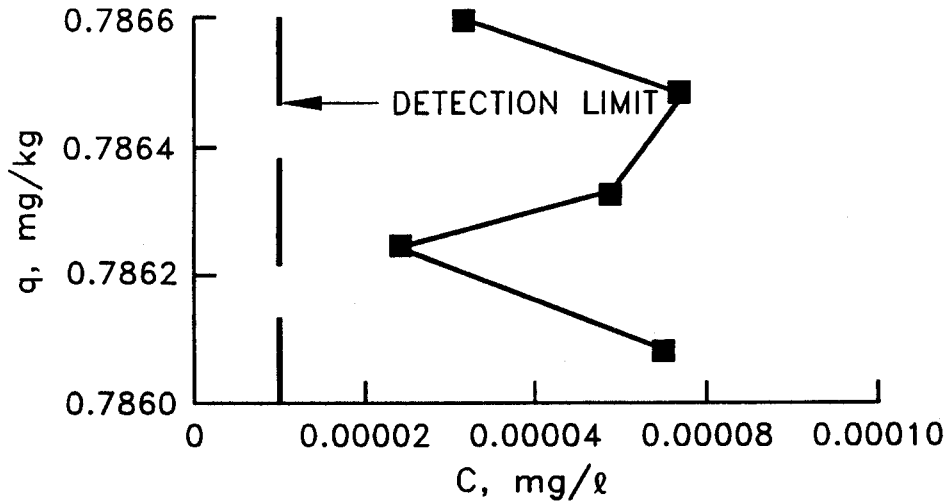

Figure B81. PCB congener C7 desorption isotherm for hot-spot sediment solidified/stabilized with 0.3 STC proprietary additive:1.0 wet sediment

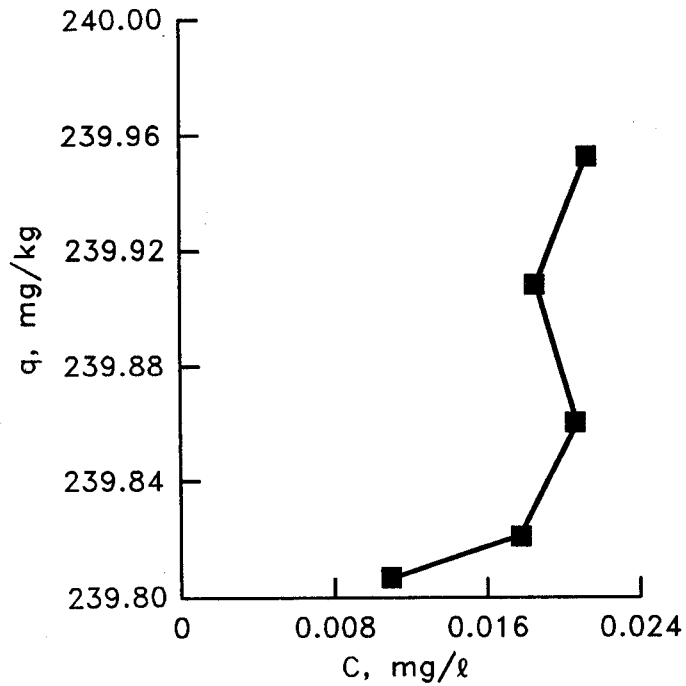

Figure B82. PCB congener C8 desorption isotherm for hot-spot sediment solidified/stabilized with 0.3 STC proprietary additive:1.0 wet sediment

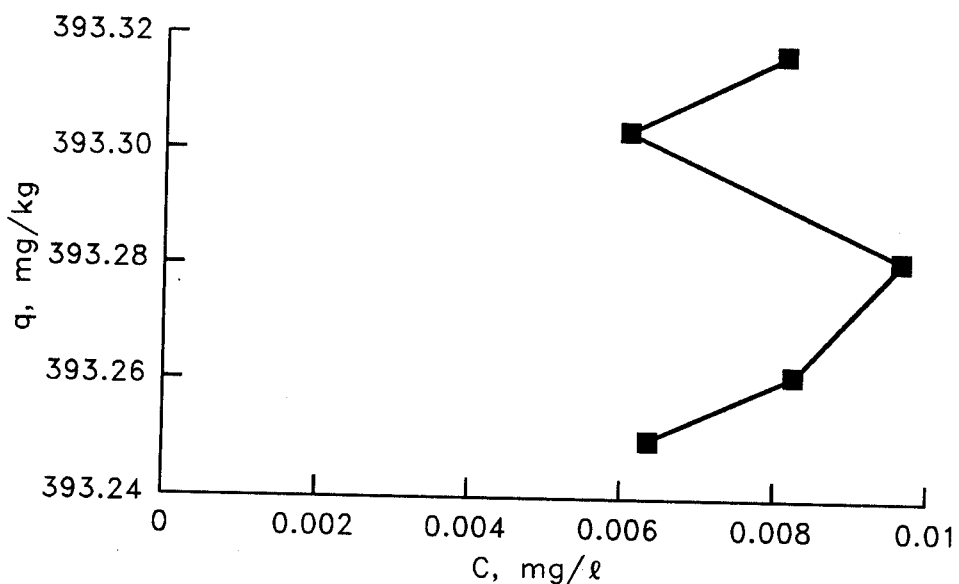

Figure B83. PCB congener C28 desorption isotherm for hot-spot sediment solidified/stabilized with 0.3 STC proprietary additive:1.0 wet sediment

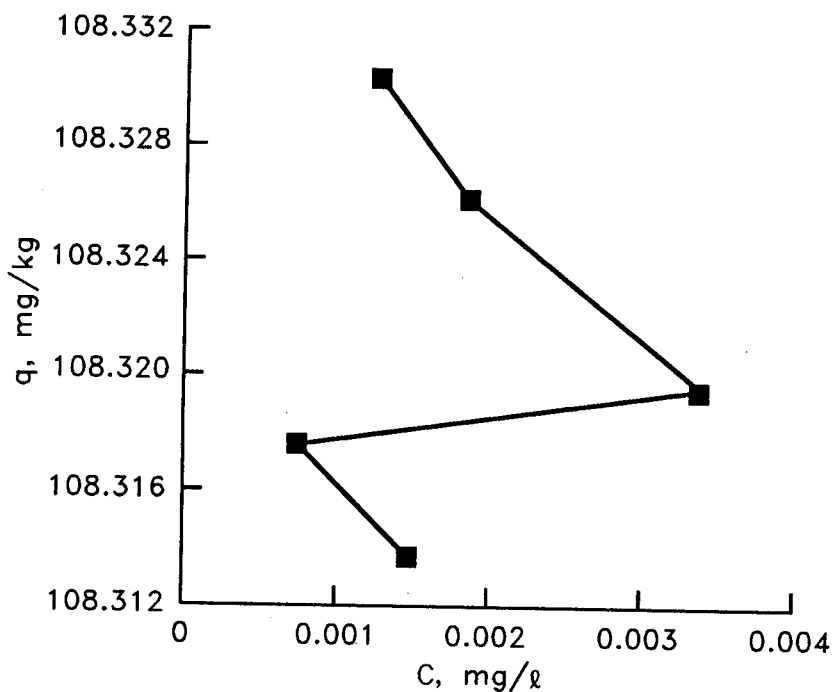

Figure B84. PCB congener C44 desorption isotherm for hot-spot sediment solidified/stabilized with 0.3 STC proprietary additive:1.0 wet sediment

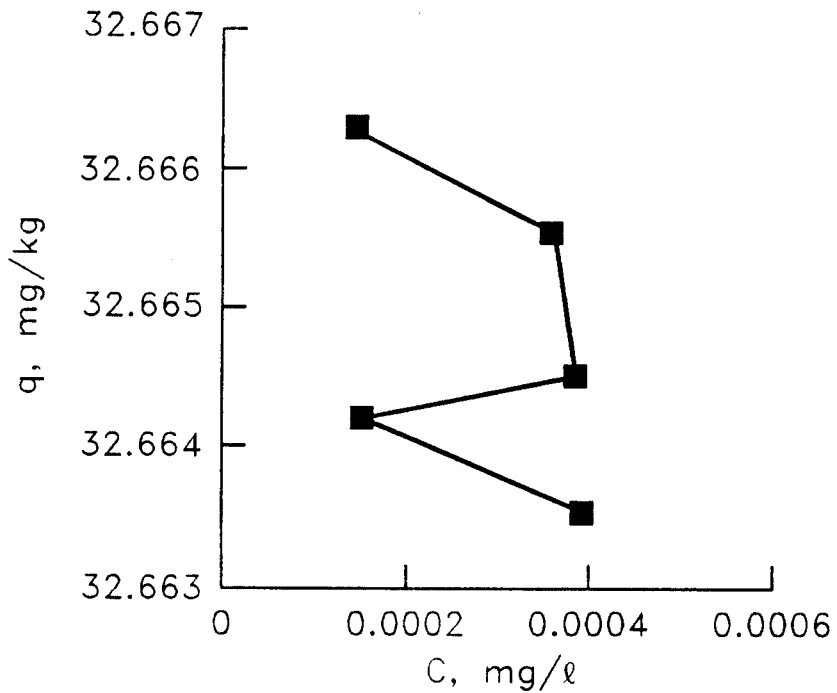

Figure B85. PCB congener C49 desorption isotherm for hot-spot sediment solidified/stabilized with 0.3 STC proprietary additive:1.0 wet sediment

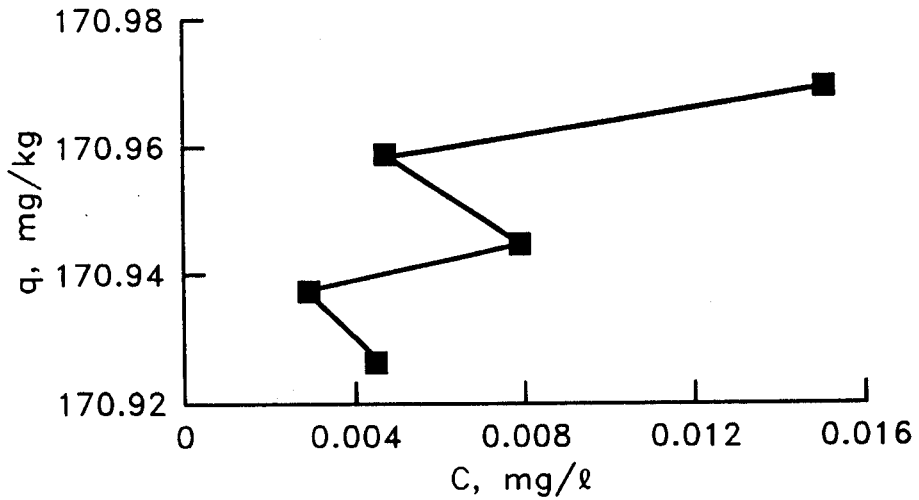

Figure B86. PCB congener C50 desorption isotherm for hot-spot sediment solidified/stabilized with 0.3 STC proprietary additive:1.0 wet sediment

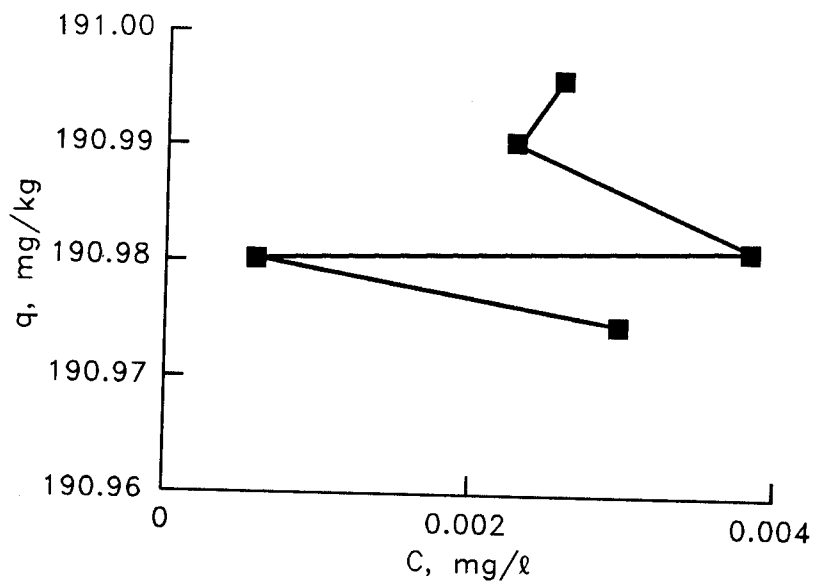

Figure B87. PCB congener C52 desorption isotherm for hot-spot sediment solidified/stabilized with 0.3 STC proprietary additive:1.0 wet sediment

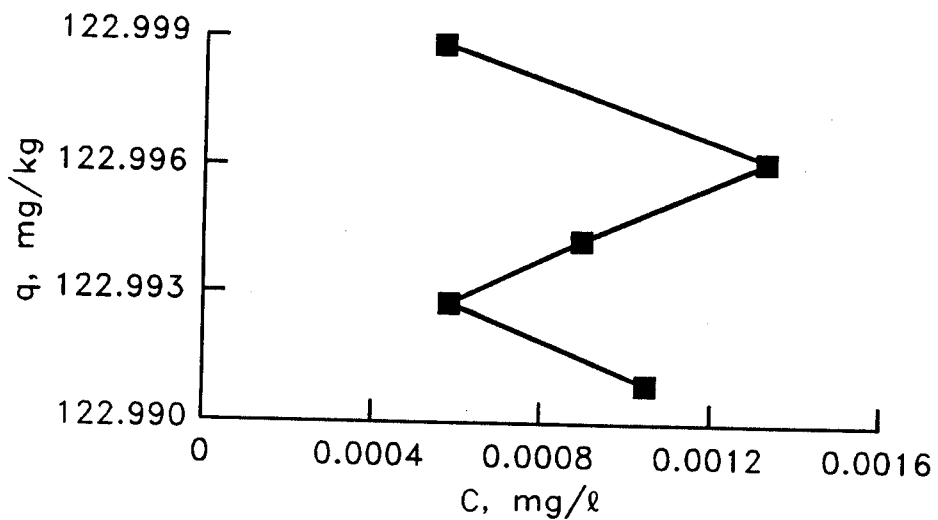

Figure B88. PCB congener C70 desorption isotherm for hot-spot sediment solidified/stabilized with 0.3 STC proprietary additive:1.0 wet sediment

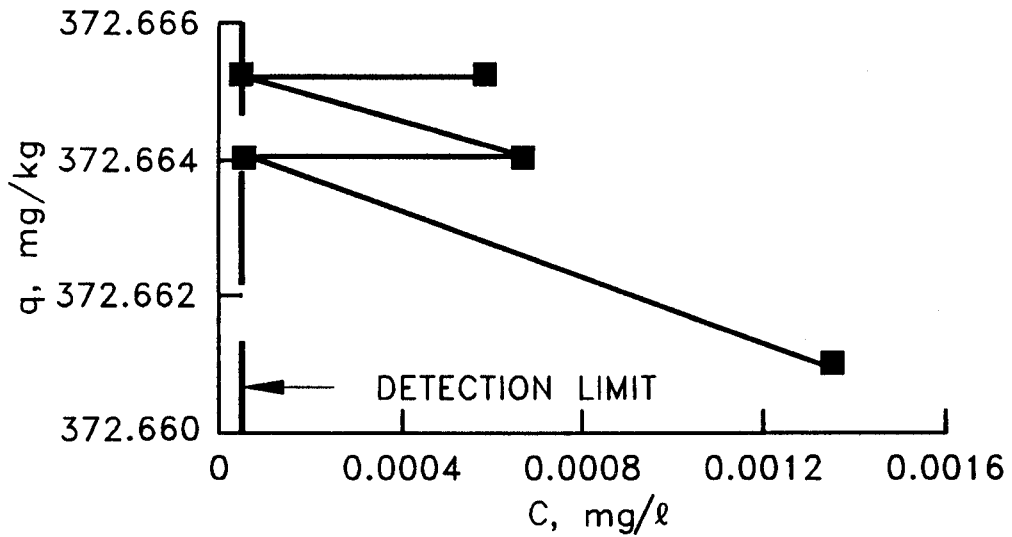

Figure B89. PCB congener C77 desorption isotherm for hot-spot sediment solidified/stabilized with 0.3 STC proprietary additive:1.0 wet sediment

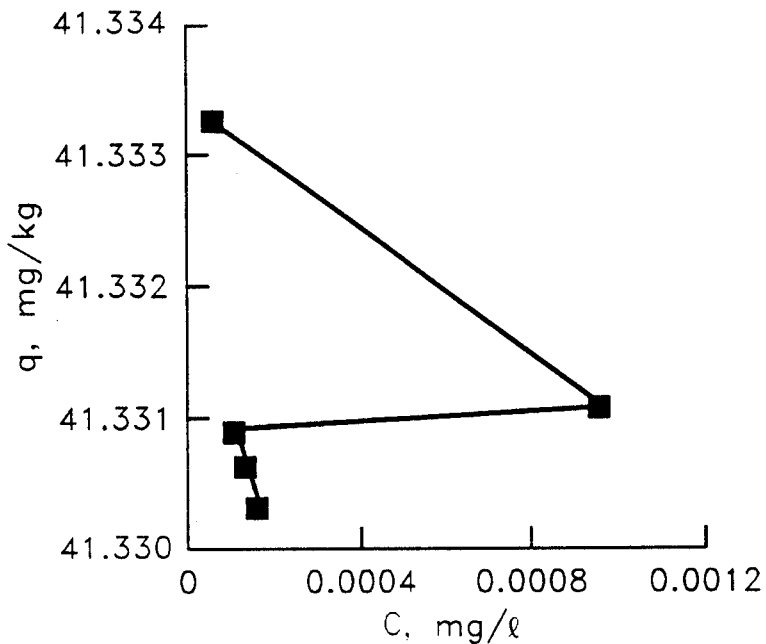

Figure B90. PCB congener C87 desorption isotherm for hot-spot sediment solidified/stabilized with 0.3 STC proprietary additive:1.0 wet sediment

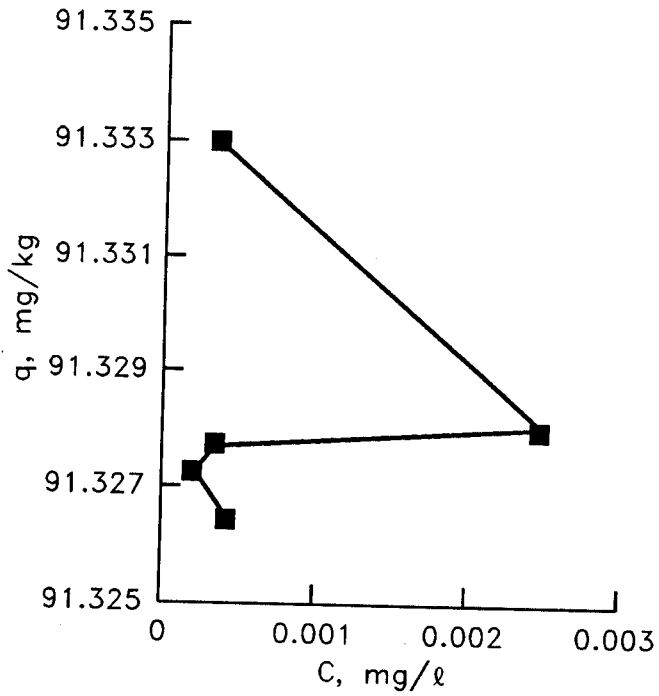

Figure B91. PCB congener C97 desorption isotherm for hot-spot sediment solidified/stabilized with 0.3 STC proprietary additive:1.0 wet sediment

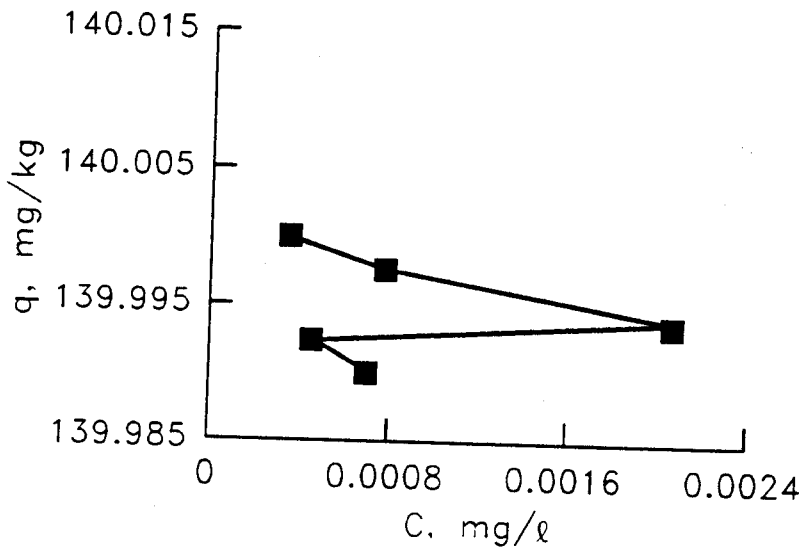

Figure B92. PCB congener C101 desorption isotherm for hot-spot sediment solidified/stabilized with 0.3 STC proprietary additive:1.0 wet sediment

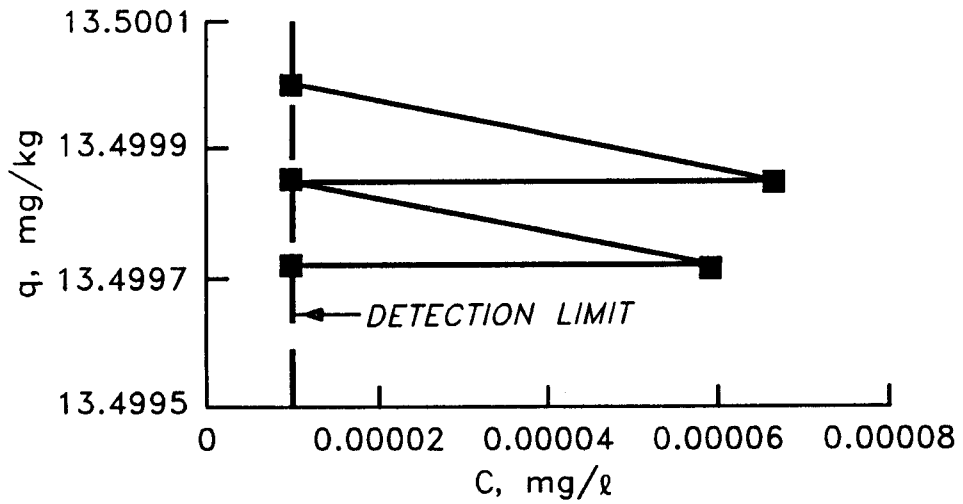

Figure B93. PCB congener C105 desorption isotherm for hot-spot sediment solidified/stabilized with 0.3 STC proprietary additive:1.0 wet sediment

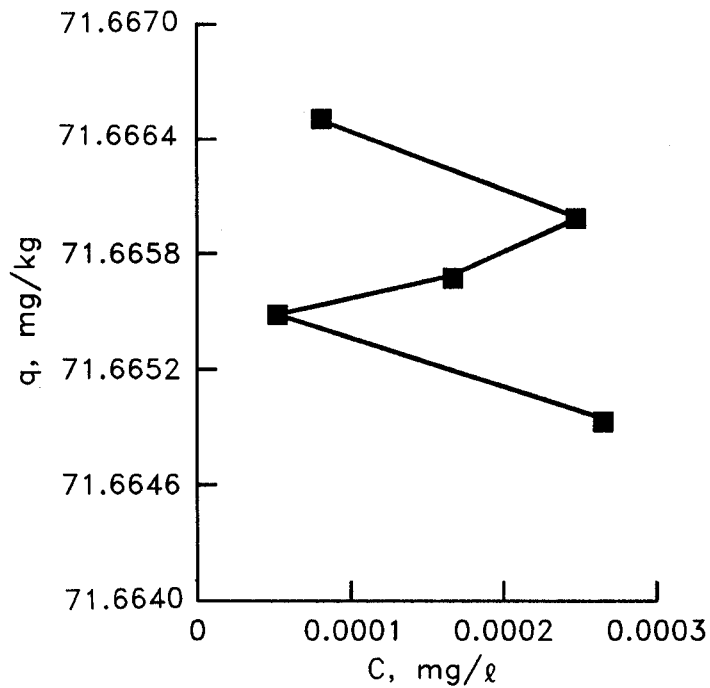

Figure B94. PCB congener C118 desorption isotherm for hot-spot sediment solidified/stabilized with 0.3 STC proprietary additive:1.0 wet sediment

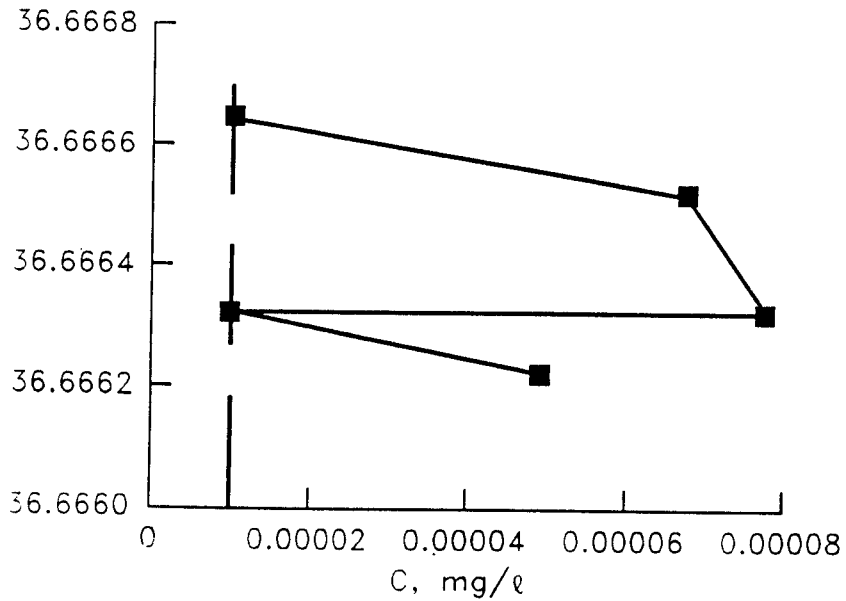

Figure B95. PCB congener C136 desorption isotherm for hot-spot sediment solidified/stabilized with 0.3 STC proprietary additive:1.0 wet sediment

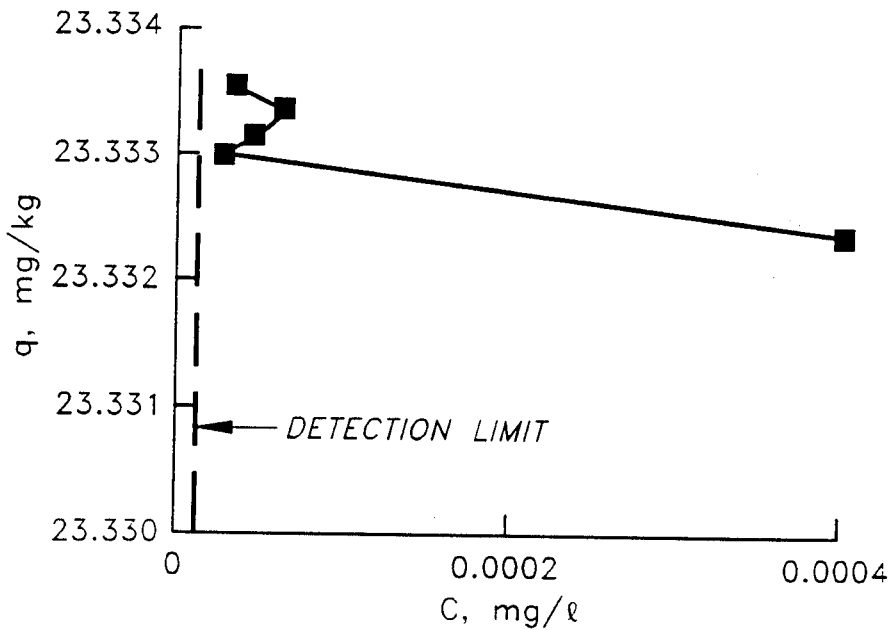

Figure B96. PCB congener C138 desorption isotherm for hot-spot sediment solidified/stabilized with 0.3 STC proprietary additive:1.0 wet sediment

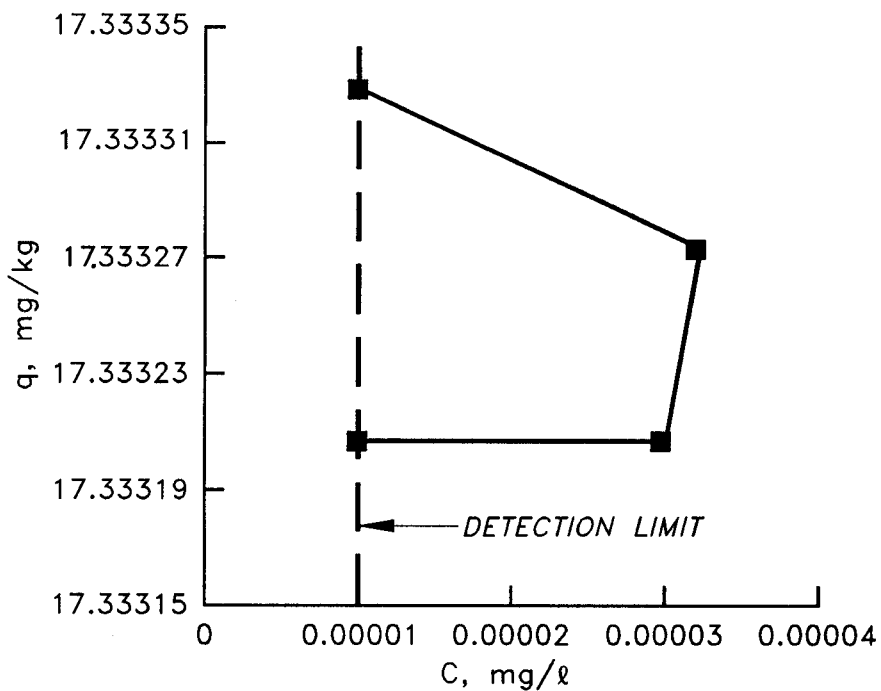

Figure B97. PCB congener C143 desorption isotherm for hot-spot sediment solidified/stabilized with 0.3 STC proprietary additive:1.0 wet sediment

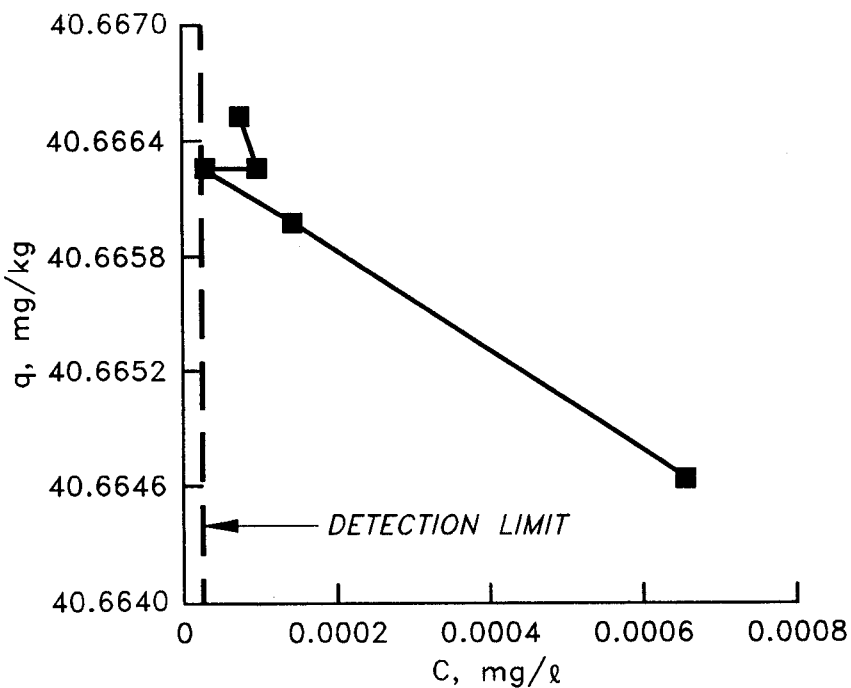

Figure B98. PCB congener C153 desorption isotherm for hot-spot sediment solidified/stabilized with 0.3 STC proprietary additive:1.0 wet sediment

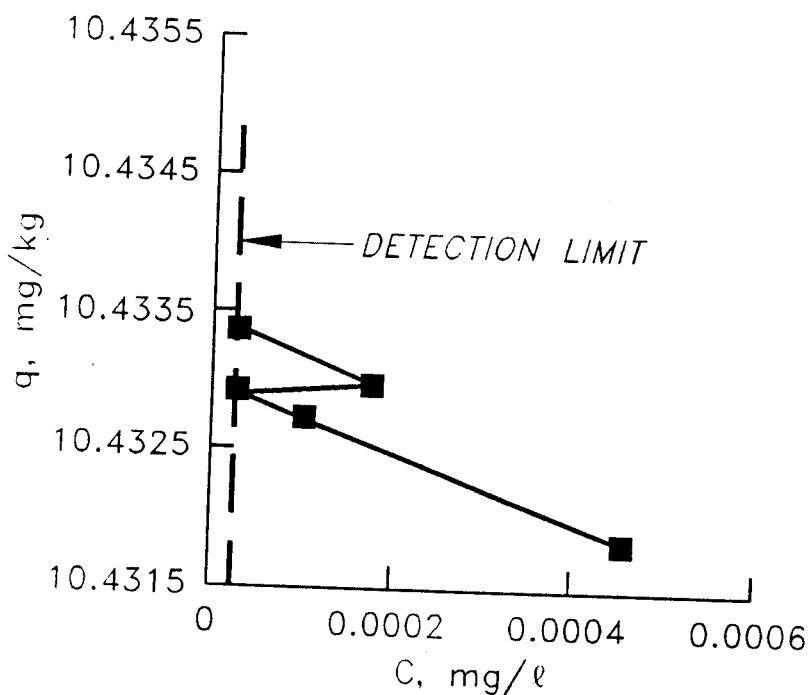

Figure B99. PCB congener C167 desorption isotherm for hot-spot sediment solidified/stabilized with 0.3 STC proprietary additive:1.0 wet sediment

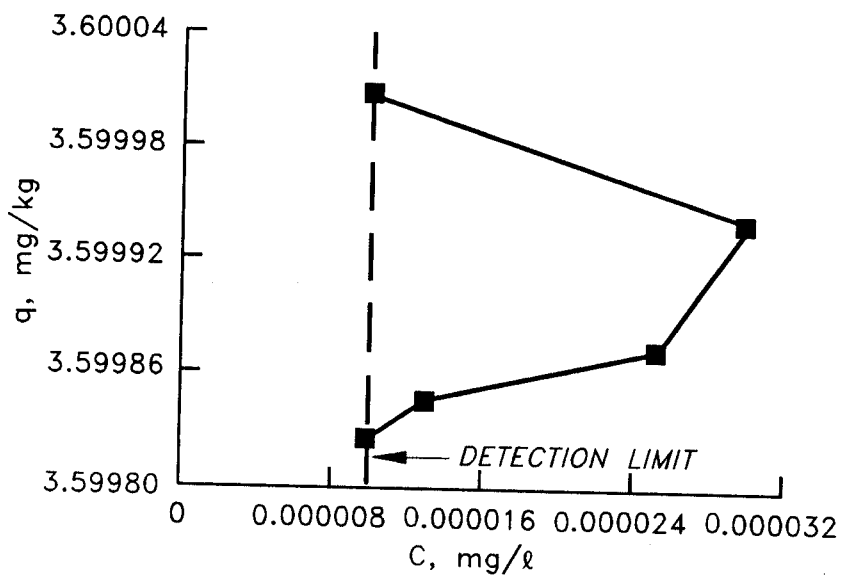

Figure B100. PCB congener C180 desorption isotherm for hot-spot sediment solidified/stabilized with 0.3 STC proprietary additive:1.0 wet sediment

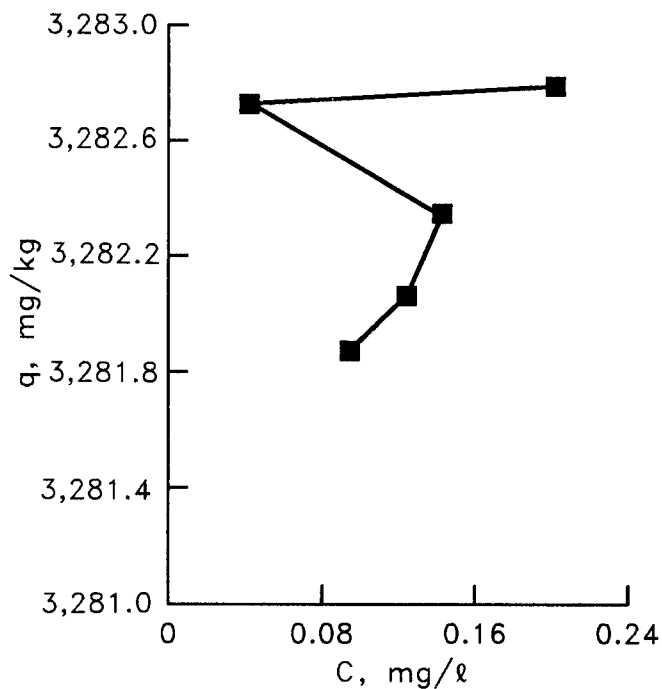

Figure B101. Total-PCB desorption isotherm for hot-spot sediment solidified/stabilized with 0.3 portland cement:1.0 wet sediment

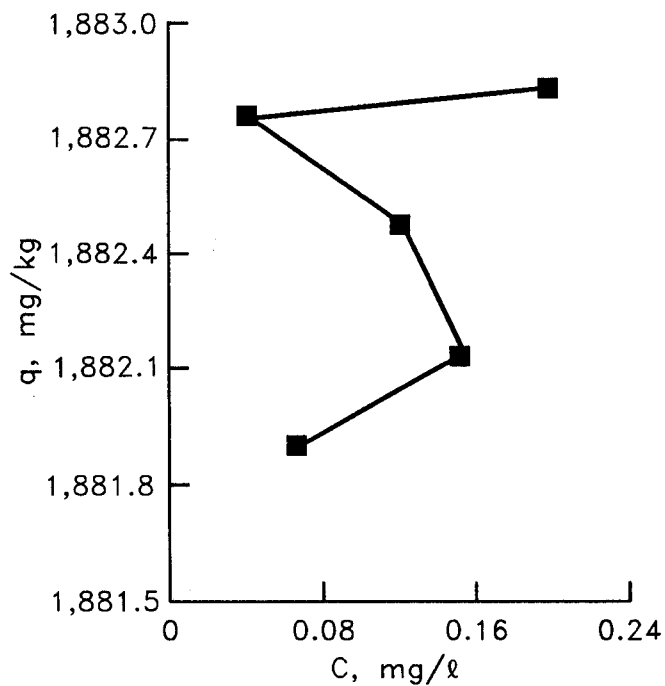

Figure B102. Aroclor 1242 desorption isotherm for hot-spot sediment solidified/stabilized with 0.3 portland cement:1.0 wet sediment

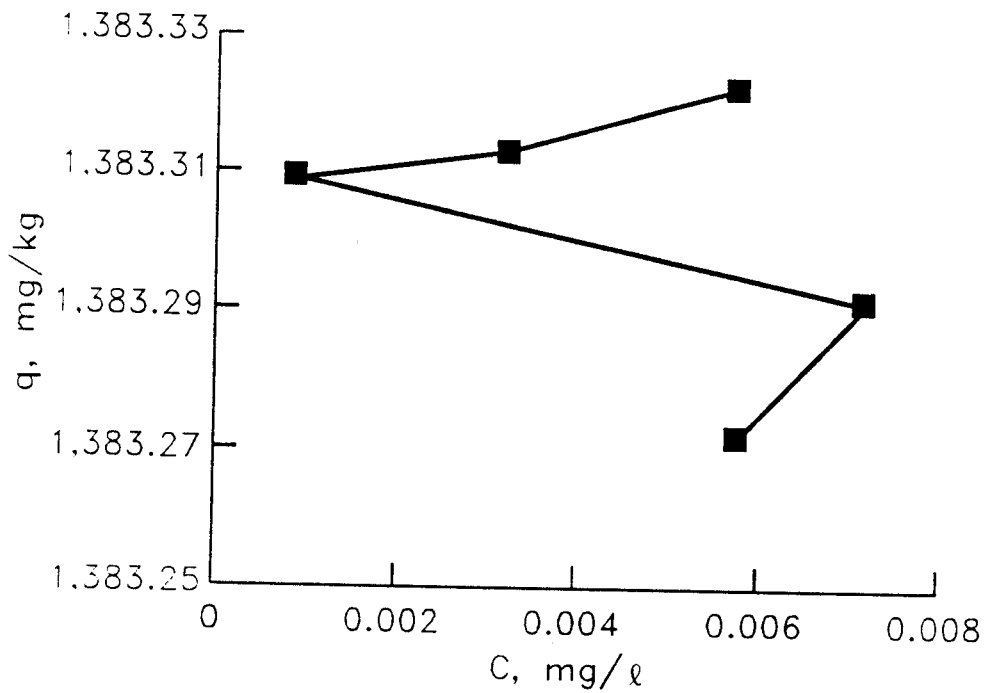

Figure B103. Aroclor 1254 desorption isotherm for hot-spot sediment solidified/stabilized with 0.3 portland cement:1.0 wet sediment

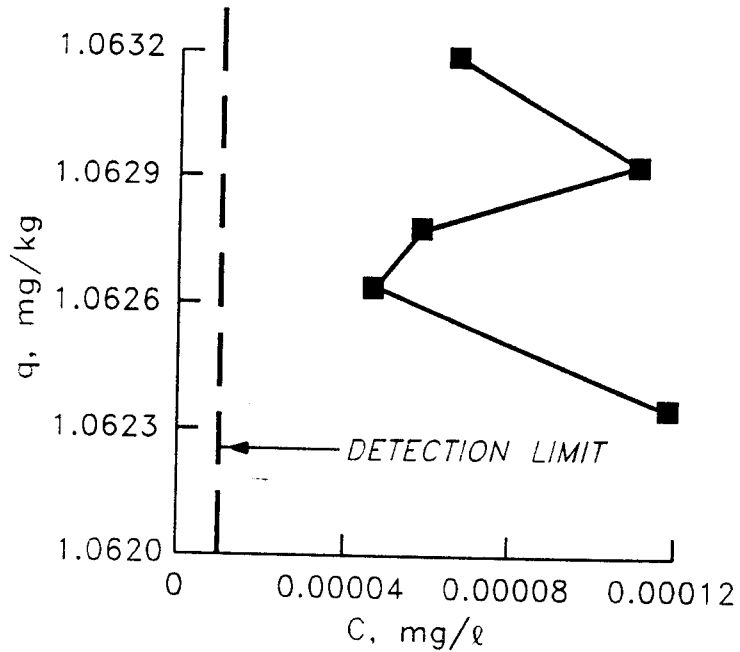

Figure B104. PCB congener C7 desorption isotherm for hot-spot sediment solidified/stabilized with 0.3 portland cement:1.0 wet sediment

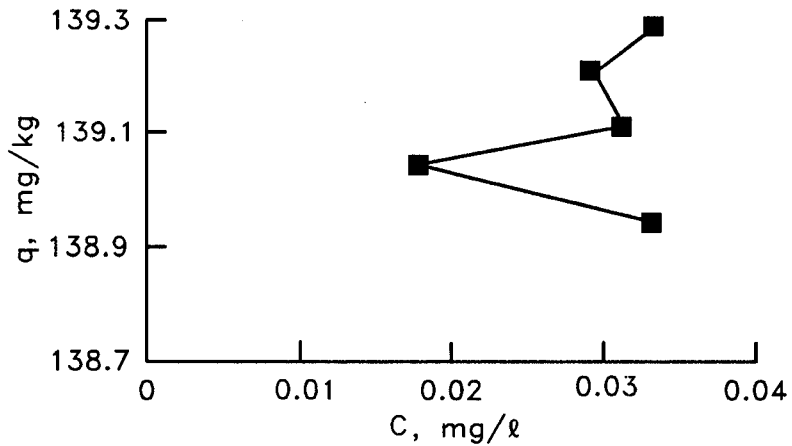

Figure B105. PCB congener C8 desorption isotherm for hot-spot sediment solidified/stabilized with 0.3 portland cement:1.0 wet sediment

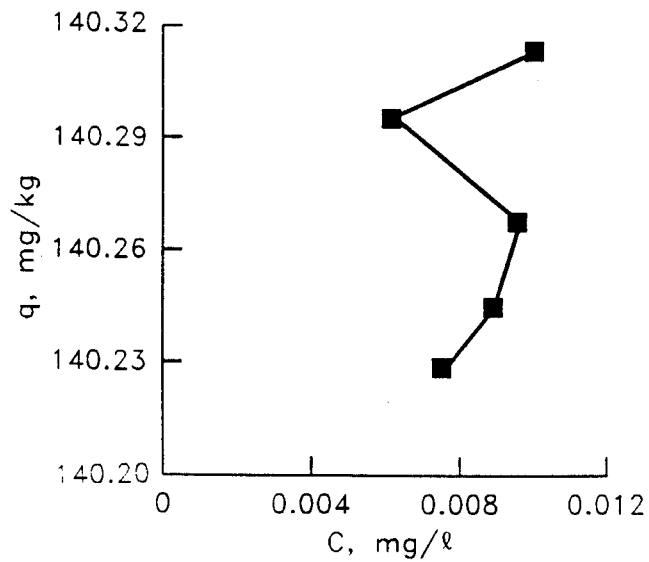

Figure B106. PCB congener C28 desorption isotherm for hot-spot sediment solidified/stabilized with 0.3 portland cement:1.0 wet sediment

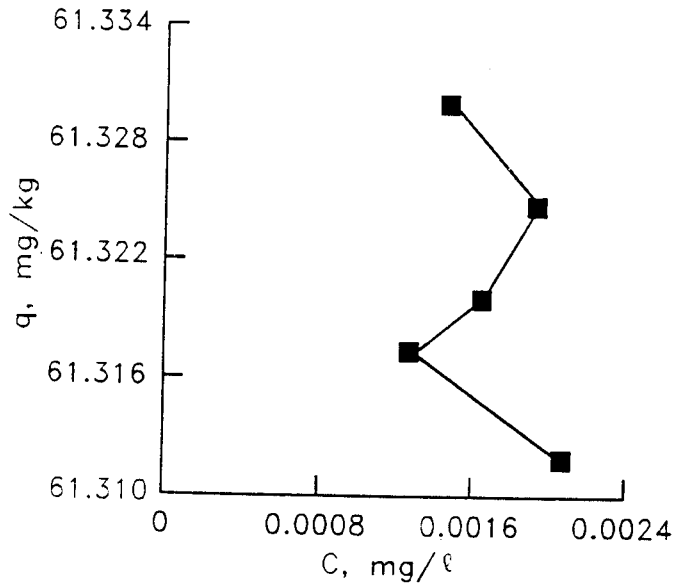

Figure B107. PCB congener C44 desorption isotherm for hot-spot sediment solidified/stabilized with 0.3 portland cement:1.0 wet sediment

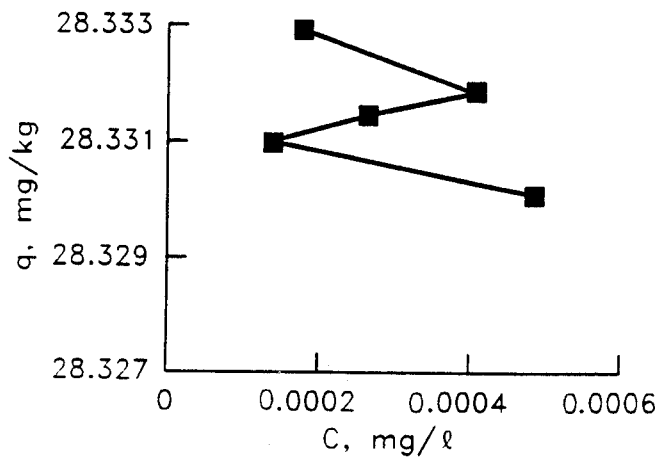

Figure B108. PCB congener C49 desorption isotherm for hot-spot sediment solidified/stabilized with 0.3 portland cement:1.0 wet sediment

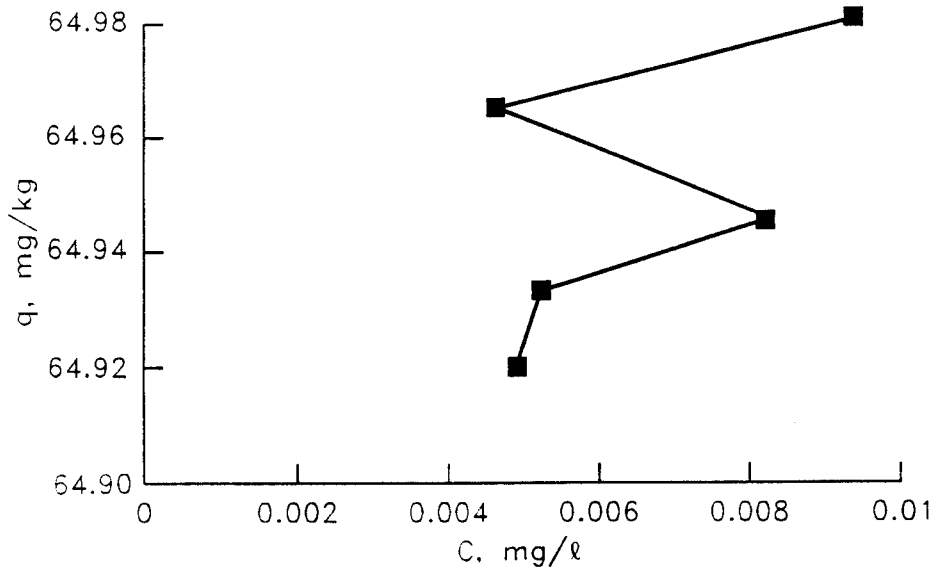

Figure B109. PCB congener C50 desorption isotherm for hot-spot sediment solidified/stabilized with 0.3 portland cement:1.0 wet sediment

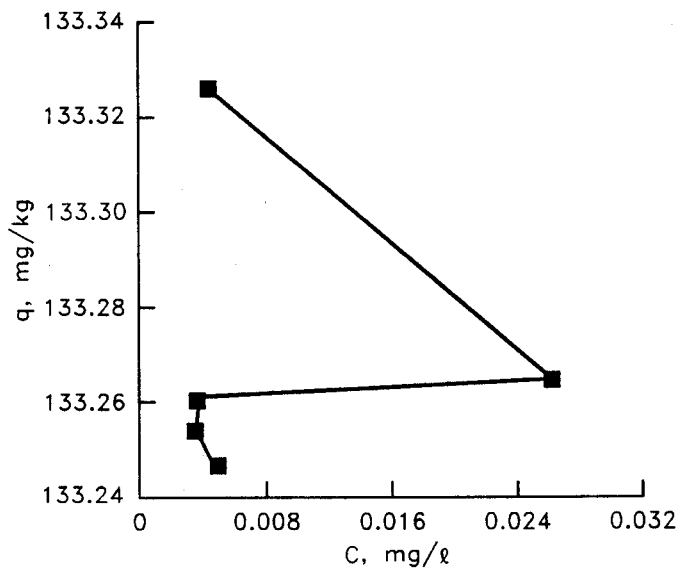

Figure B110. PCB congener C52 desorption isotherm for hot-spot sediment solidified/stabilized with 0.3 portland cement:1.0 wet sediment

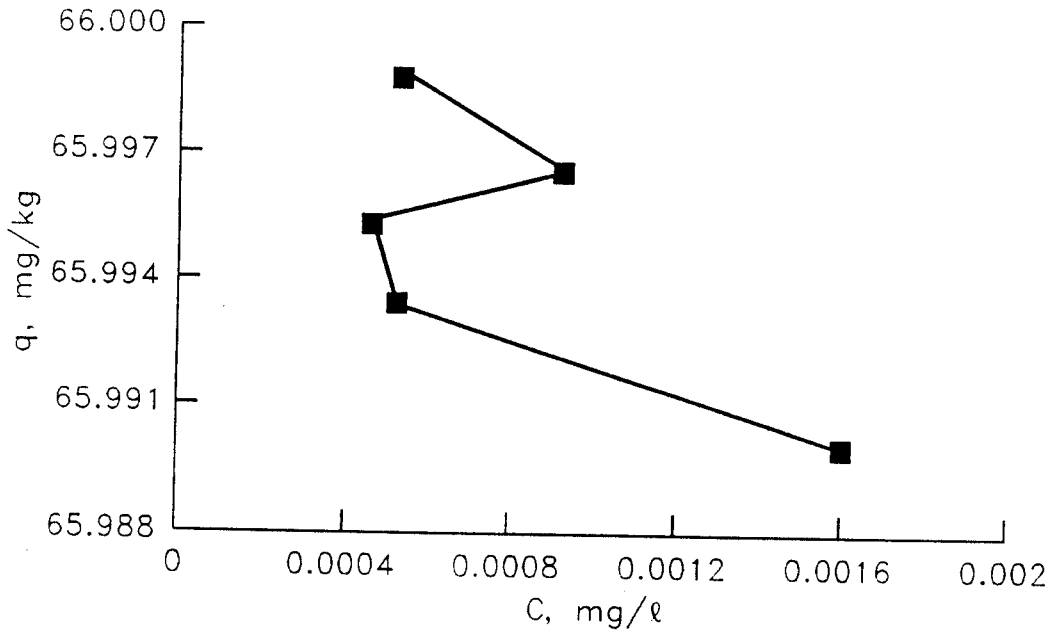

Figure B111. PCB congener C70 desorption isotherm for hot-spot sediment solidified/stabilized with 0.3 portland cement:1.0 wet sediment

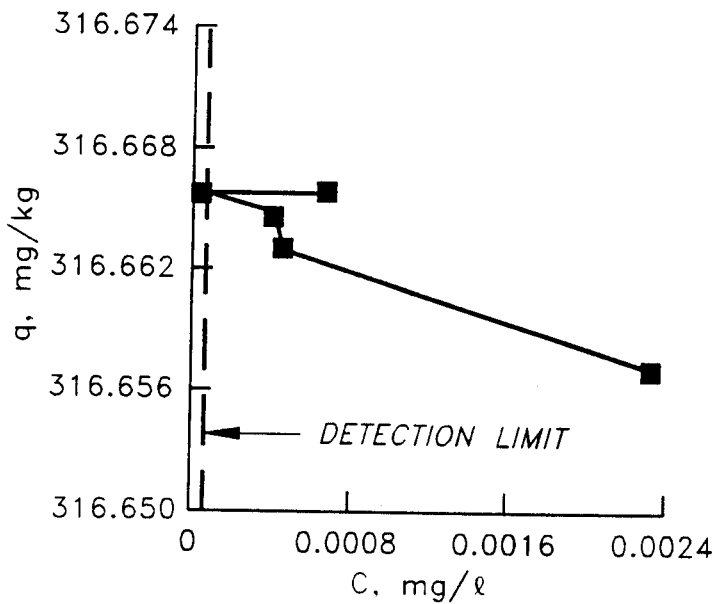

Figure B112. PCB congener C77 desorption isotherm for hot-spot sediment solidified/stabilized with 0.3 portland cement:1.0 wet sediment

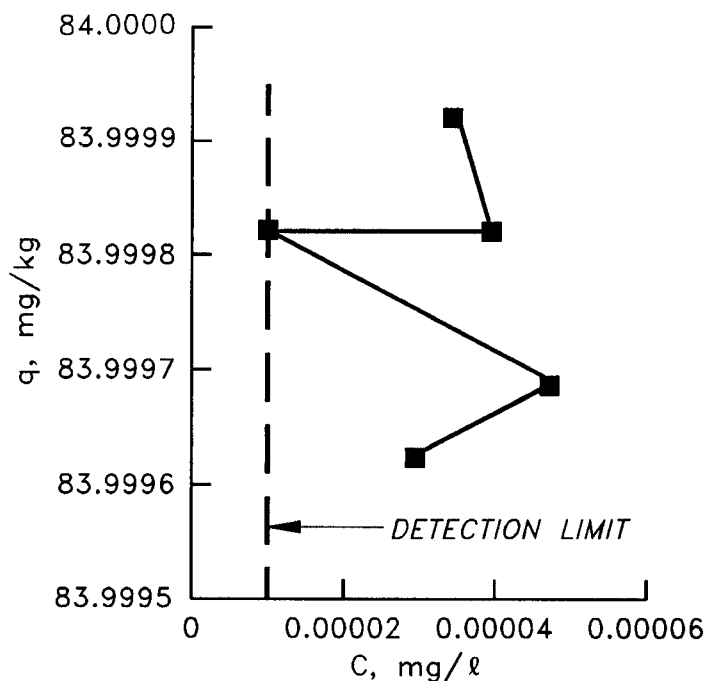

Figure B113. PCB congener C87 desorption isotherm for hot-spot sediment solidified/stabilized with 0.3 portland cement:1.0 wet sediment

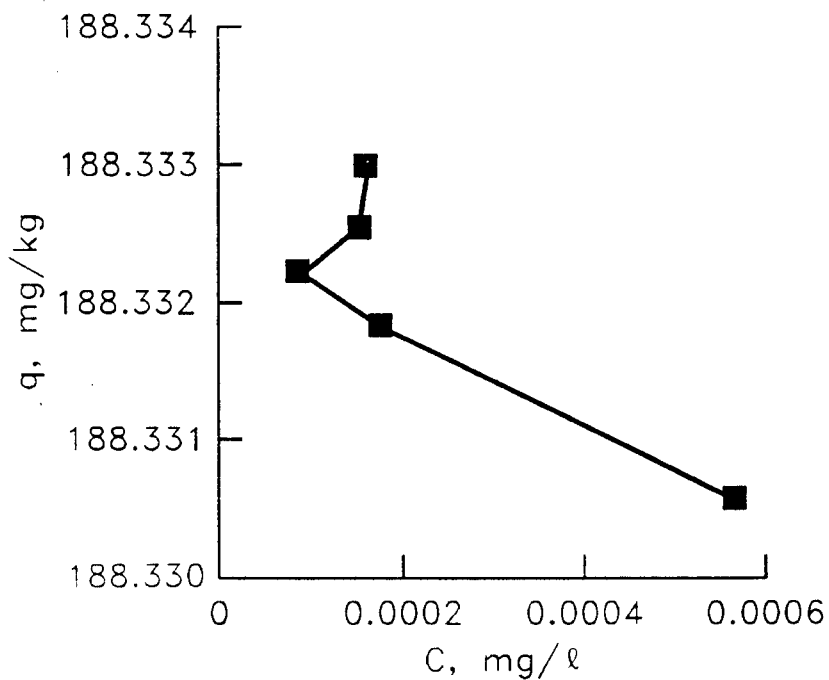

Figure B114. PCB congener C97 desorption isotherm for hot-spot sediment solidified/stabilized with 0.3 portland cement:1.0 wet sediment

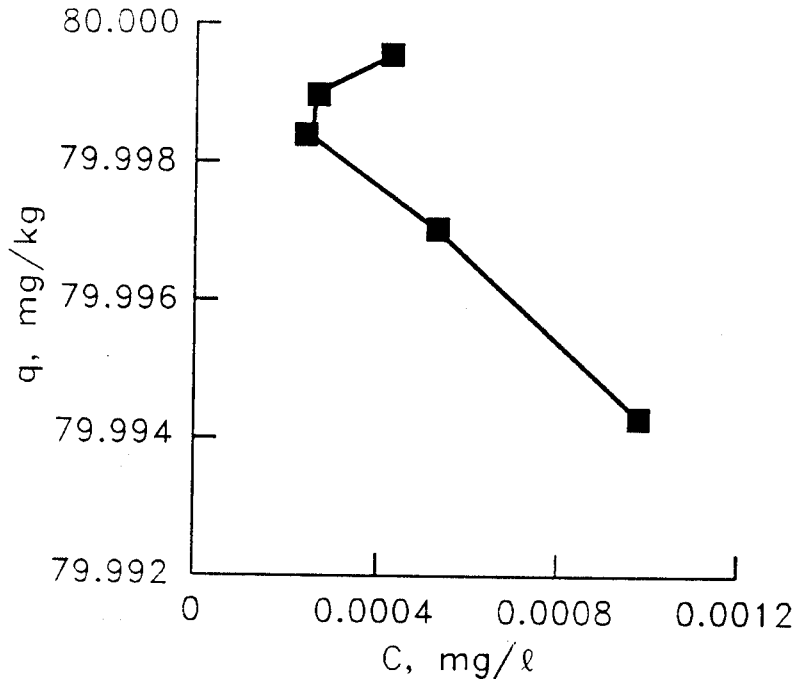

Figure B115. PCB congener C101 desorption isotherm for hot-spot sediment solidified/stabilized with 0.3 portland cement:1.0 wet sediment

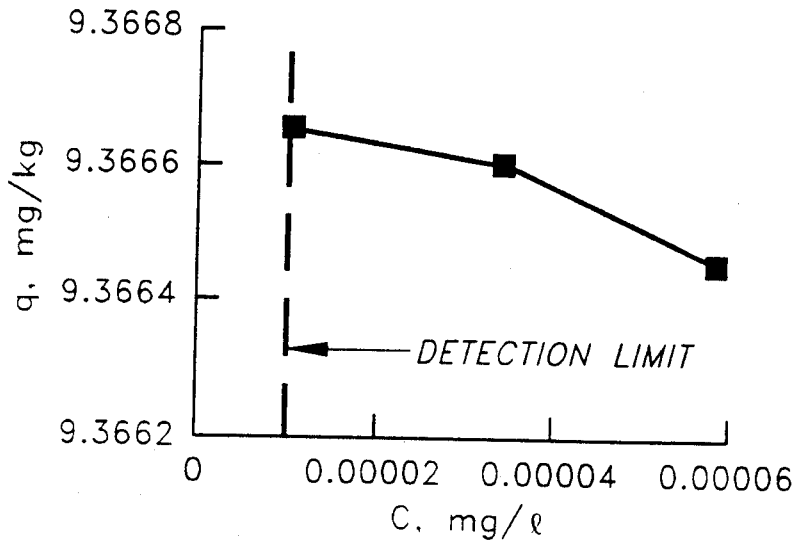

Figure B116. PCB congener C105 desorption isotherm for hot-spot sediment solidified/stabilized with 0.3 portland cement:1.0 wet sediment

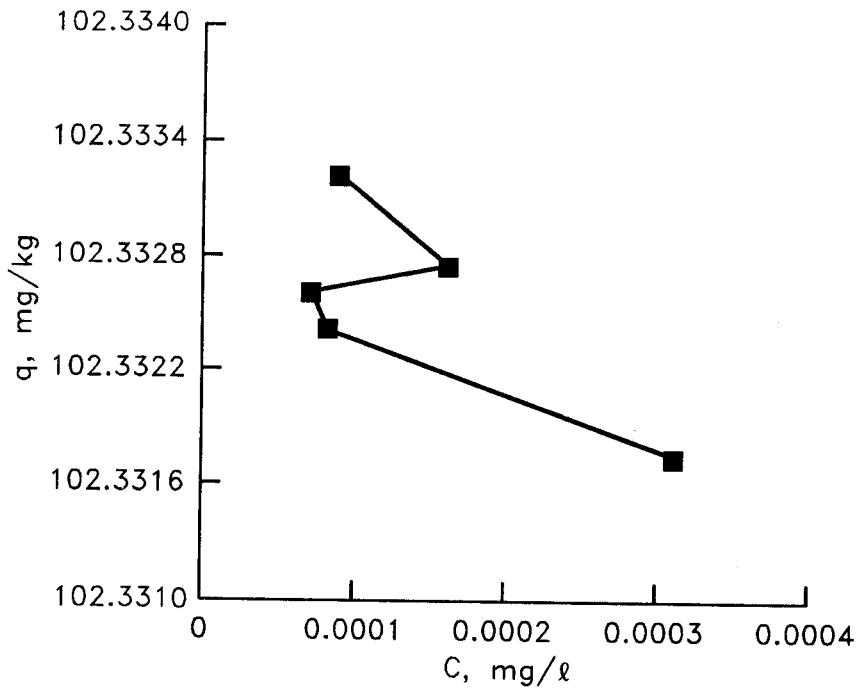

Figure B117. PCB congener C118 desorption isotherm for hot-spot sediment solidified/stabilized with 0.3 portland cement:1.0 wet sediment

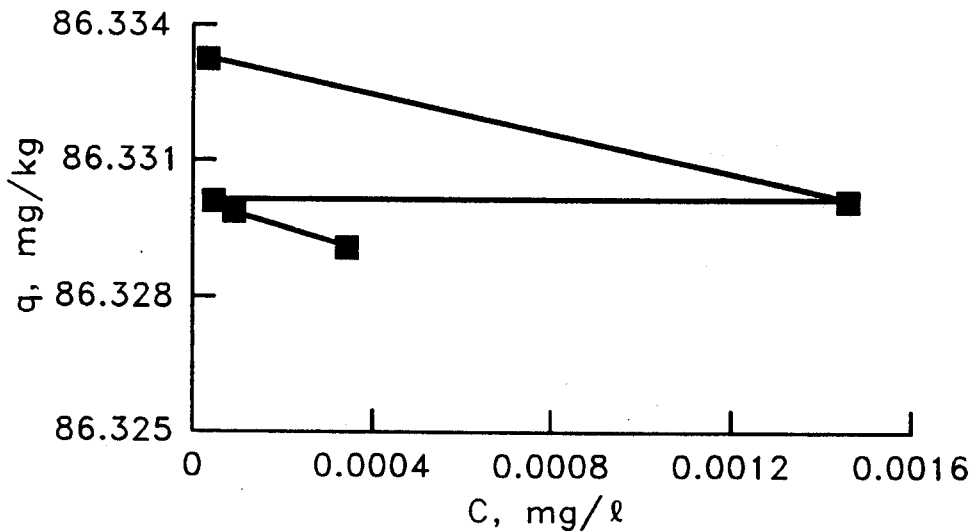

Figure B118. PCB congener C136 desorption isotherm for hot-spot sediment solidified/stabilized with 0.3 portland cement:1.0 wet sediment

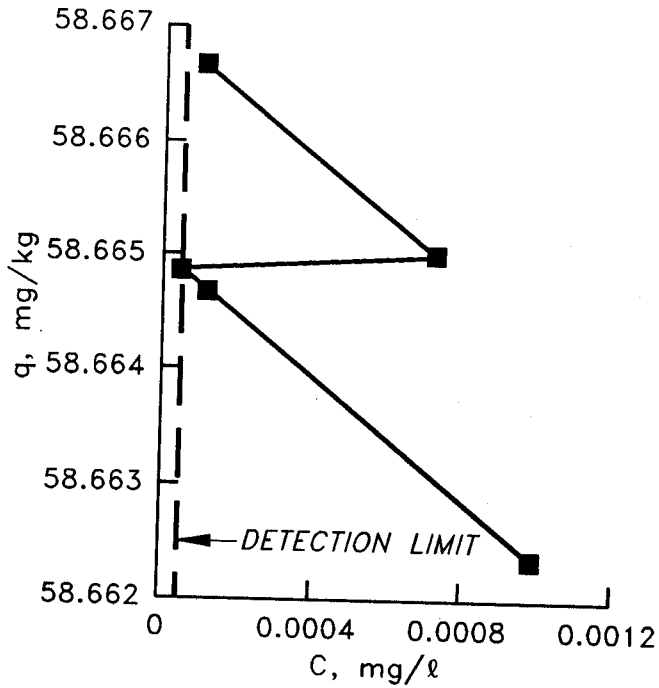

Figure B119. PCB congener C138 desorption isotherm for hot-spot sediment solidified/stabilized with 0.3 portland cement:1.0 wet sediment

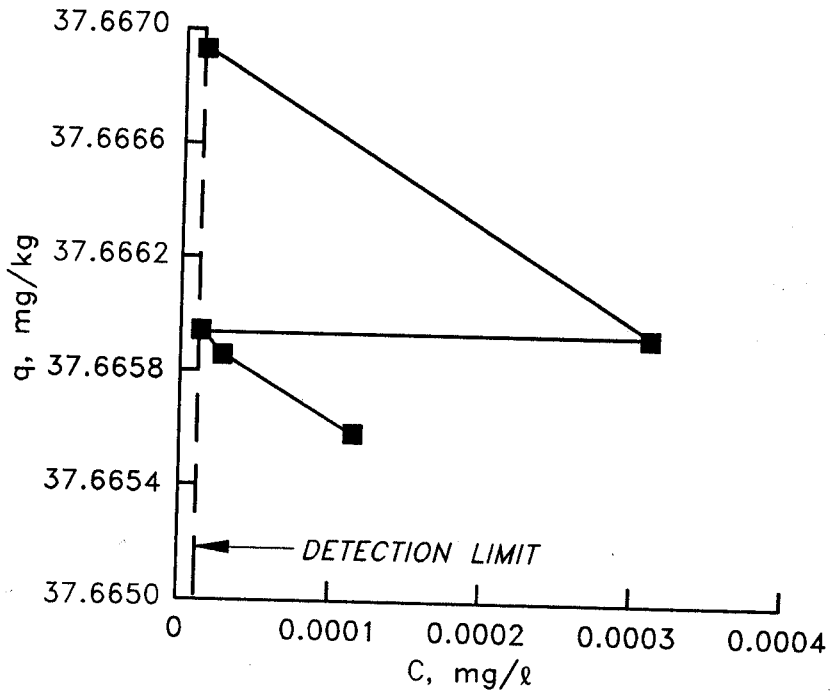

Figure B120. PCB congener C143 desorption isotherm for hot-spot sediment solidified/stabilized with 0.3 portland cement:1.0 wet sediment

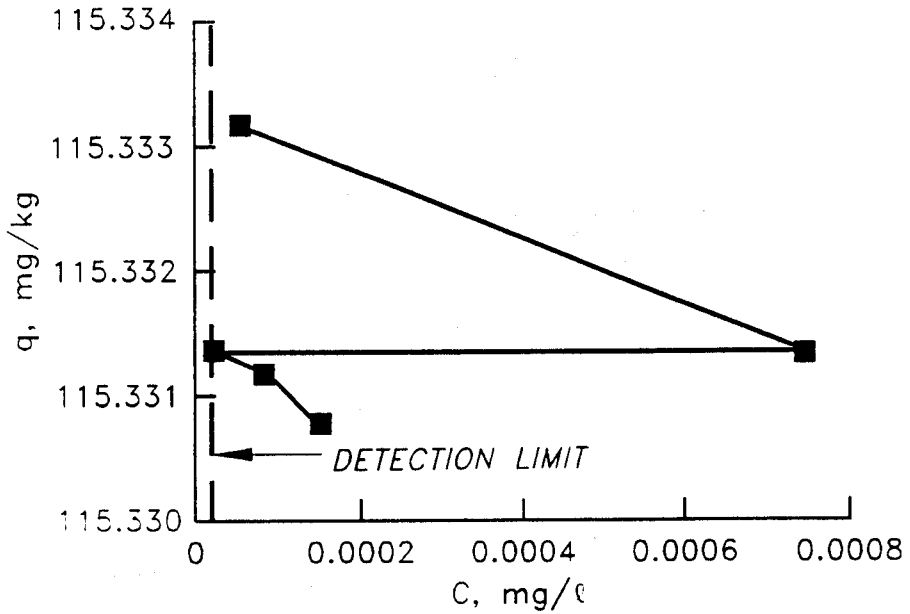

Figure B121. PCB congener C153 desorption isotherm for hot-spot sediment solidified/stabilized with 0.3 portland cement:1.0 wet sediment

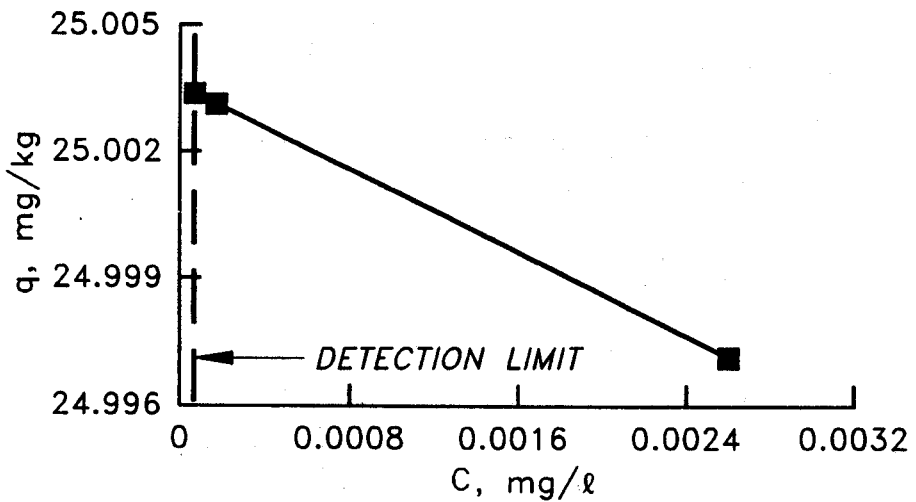

Figure B122. PCB congener C167 desorption isotherm for hot-spot sediment solidified/stabilized with 0.3 portland cement:1.0 wet sediment

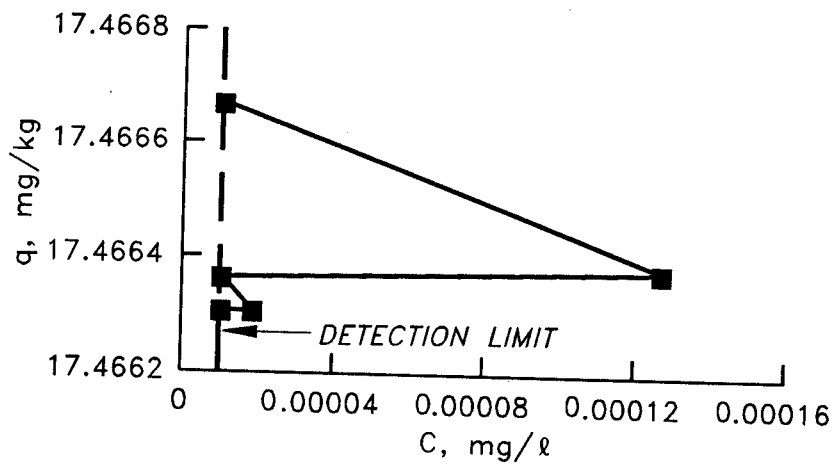

Figure B123. PCB congener C180 desorption isotherm for hot-spot sediment solidified/stabilized with 0.3 portland cement:1.0 wet sediment